

BLOWN AIR GAS BURNERS

Ecoflam



MAX GAS 70 P AB

MAX GAS 105 P AB

MAX GAS 120 P AB

Low Nox

220V 50/60 Hz



420010386102

420010386102

29.11.2011

Models : Max Gas 70-105-120 P AB		Gas family			
		G20	G25	G31	G30
Max. gas pressure*	mbar	360	360	360	360
Min. gas pressure*	mbar	12	12	30	30
Fuel L.C.V.	kcal/Nm ³	8.570	7.370	22.260	29.320
Models : Max Gas 70 P AB					
Gas flow rate	max.	7,04 Nm ³ /h	8,19 Nm ³ /h	2,71 Nm ³ /h	2,06 Nm ³ /h
	min.	2,52 Nm ³ /h	2,93 Nm ³ /h	0,97 Nm ³ /h	0,74 Nm ³ /h
Models : Max Gas 105 P AB					
Gas flow rate	max.	11,21 Nm ³ /h	13,04 Nm ³ /h	4,32 Nm ³ /h	3,28 Nm ³ /h
	min.	4,67 Nm ³ /h	4,68 Nm ³ /h	1,55 Nm ³ /h	1,17 Nm ³ /h
Models : Max Gas 120 P AB					
Gas flow rate	max.	12,07 Nm ³ /h	14,04 Nm ³ /h	4,65 Nm ³ /h	3,53 Nm ³ /h
	min.	4,67 Nm ³ /h	4,68 Nm ³ /h	1,55 Nm ³ /h	1,17 Nm ³ /h

* : Minimum/maximum gas inlet pressures depend by the gas train matched to the burner. The values are written on the gas trains manual.

		Max Gas 70 P AB	Max Gas 105 P AB	Max Gas 120 P AB
Termal power max.	kW	70	108	120
	kcal/h	60.340	96.100	103.450
Termal power max	kW	25	40	40
	kcal/h	21.600	34.480	34.480

Gas family :	AT	I_{2H}, I_{3B/P}	BE	I_{2E(R)B}, I_{3P}	DE	I_{2E}, I_{3B/P}	DK	I_{2H}, I_{3B/P}	SE	I_{2H}, I_{3B/P}
	ES	I_{2H}, I_{3P}	FI	I_{2H}, I_{3B/P}	FR	I_{2Er}, I_{3B/P}	GB	I_{2H}, I_{3B/P}	NL	I_{2L}, I_{3B/P}
	GR	I_{2H}, I_{3B/P}	IE	I_{2H}, I_{3B/P}	IT	I_{2H}, I_{3B/P}	PT	I_{2H}, I_{3B/P}		

WORKING FIELDS

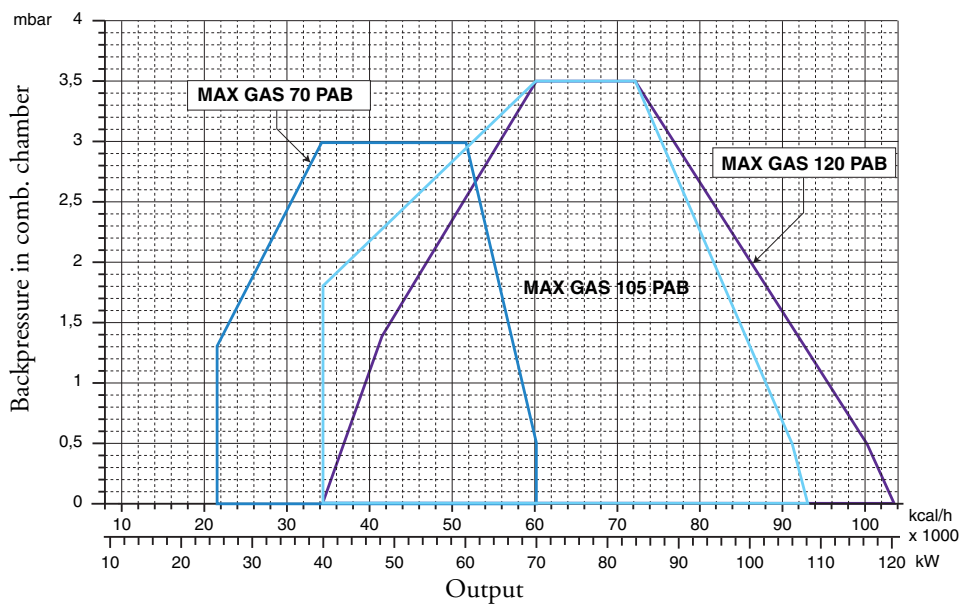

OVERALL DIMENSIONS

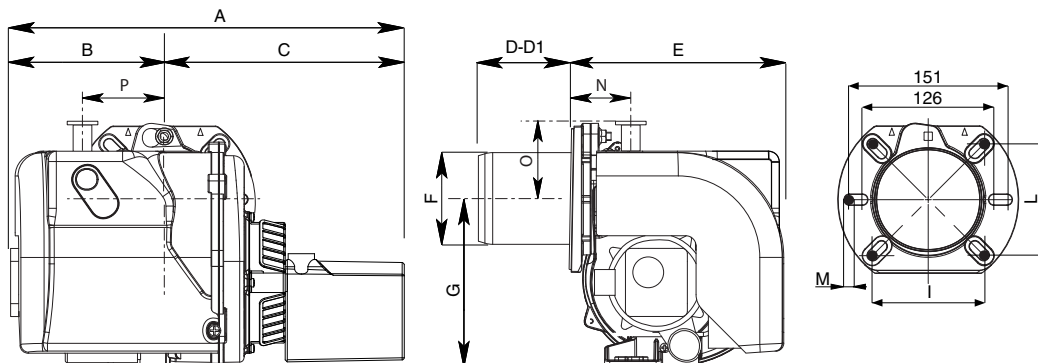

MODELS	A	B	C	D	D1	E	F	G	I	L	M	N	O	P
MAX GAS 70 P AB	386	155	231	85	185	282	89	160	100/120	100/120	M8	52	71	82
MAX GAS 105 P AB	400	169	231	140	220	282	89	160	100/120	100/120	M8	52	71	82
MAX GAS 120 P AB	400	169	231	160	240	282	98	160	100/120	100/120	M8	52	71	82

D = SHORT HEAD D1= LONG HEAD

Installation must be carried out in compliance with the local provisions

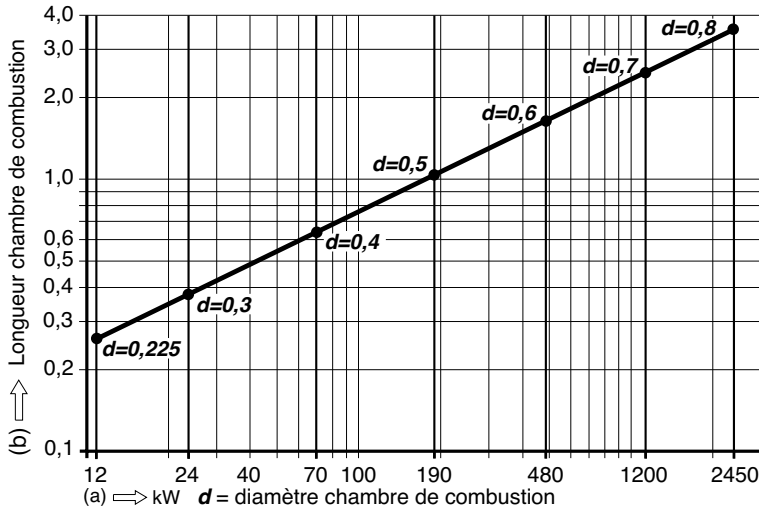

The burners have been certified in combustion chambers according to EN 676 standards. Consult the burner manufacturer if the combustion chamber of the boiler in which the burner is to be installed has smaller dimensions.

STARTING-UP THE BURNER

PRELIMINARY CHECKS

Before starting up the boiler check the following: - gas type and feed pressure; - gas valves closed; - the seals in the pipe fittings; - gas pipe breather and input pressure; - that the cable complies with the diagram and the phase and neutral wires correspond; - that the burner shuts down when the boiler thermostat opens; - the seal of the boiler furnace which prevents air from entering; - the seal on the flue-boiler pipe fitting; - the condition of the flue (sealed, free from blockage, etc). If all these conditions are present, start the burner. The control device starts the motor to carry out prewashing of the combustion chamber. During this prewash period (about 30 seconds) the device checks that air pressure is correct via the air pressure switch. At the end, it supplies power to the transformer and opens the gas valves. The flame must be lit and stabilize within 3 seconds, which is the device's safety time limit. Check to ensure the flame is lit before placing any control instrument in the flue. Adjust and check the gas flow necessary for the boiler at the meter. Adjust the air flow according to the gas flow to obtain correct combustion.

IMPORTANT ADVICE

All adjustable parts must be fixed by the installer after making adjustments. Check flue combustion after each adjustment. The CO₂ values must be approx. 9.7 (G20) 9.6 (G25) 11.7 (G30) 11.7 (G31) and the CO must be less than 75 ppm.

(LANDIS & STAЕFA LGB 21/LGB 22 UP CYCLE

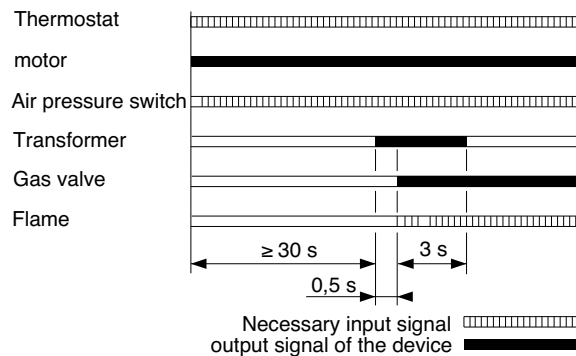

CALCULATION OF WORKING OUTPUT OF THE BURNER

To calculate the burner's working output, in kW, proceed as follows:

- Check at the meter the quantity of supplied litres and the duration, in seconds, of the reading, then calculate the burner's output through the following formula:

e = Litres of gas

s = Time in seconds

$$\frac{e}{s} \times f = \text{kW}$$

f	G20 = 34,02
	G25 = 29,25
	G30 = 116
	G31 = 88

ADJUSTING THE AIR PRESSURE SWITCH

The air pressure switch must be adjusted so that an insufficient air flow does not allow the CO value to exceed 1% in volume. After having adjusted the gas flow and obtained optimum combustion ($CO_2 = 9.5$ to 9.8% and a CO value of less than 75 ppm), the air pressure switch must be adjusted. Remove the cover with the burner operating, cover the air intake progressively with a piece of cardboard to obtain a value of $CO_2 = 10.8$ (G20-G25) > 13 (G30-G31) and a CO value of less than 5,000 ppm. Adjust the air pressure switch until the burner shuts down. Remove the cardboard from the air intake and start up the burner again. Replace the cover.

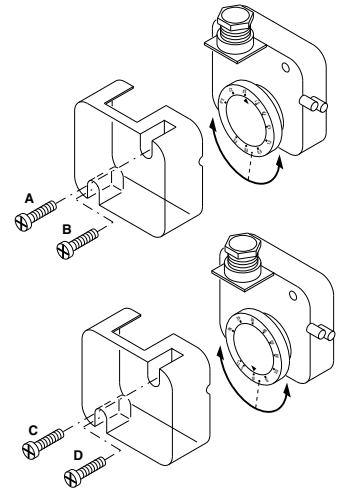

ADJUSTING THE GAS PRESSURE SWITCH

Adjust the pressure switch to 50% of the rated pressure of the gas used.

RARED PRESSURE:

G 20 =	20 mbar
G 25 =	25 mbar
G 30 =	29 mbar
G 31 =	37 mbar

ADJUSTMENT AIR SERVOMOTOR (SIEMENS SQN 75)

Remove cover to enter the adjusting cams. Adjust cams through the suitable key (on issue) and a screwdriver.

FOR THE ADJUSTEMENT OPERATE ON SERVOMOTOR CAMS AND MAKE REFERENCE TO THE INDEX ON AIR DAMPER (SEE Pic. A)

Description:

- I – Adjusting cam (BLUE) for air damper position on burner’s shutdown (totally close 0°).
- II – Adjusting cam (ORANGE) for ignition position and Low Flame (adjust by the screwdriver).
- III – Adjusting cam (RED) for High Flame position (max.output air damper setting = 9).
- IV – Adjusting cam (BLACK) to allow the opening of High flame solenoid valve (cam position has to be between II and III).

SETTING THE FIRING HEAD

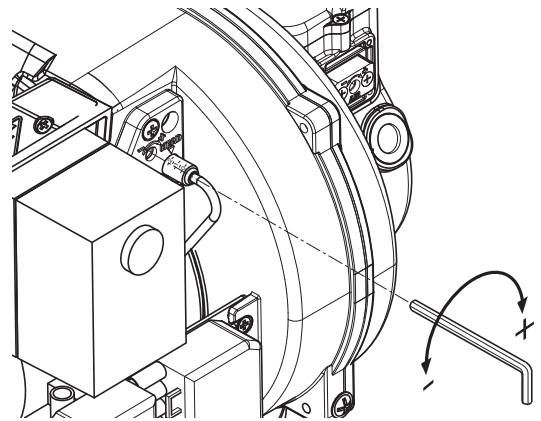

FLAME DETECTION SYSTEM CHECK

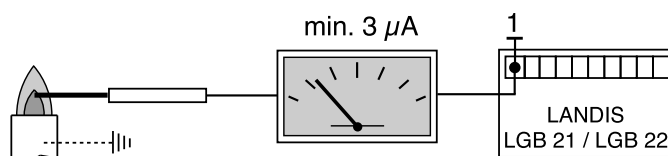

With the burner switched off, connect a DC microammeter with a $0 \div 50$ or $0 \div 100 \mu A$ dial. When the burner is running, and is properly adjusted, the value read must be steady and never be smaller than $3 \mu A$ (Landis).

POSITION OF ELECTRODES

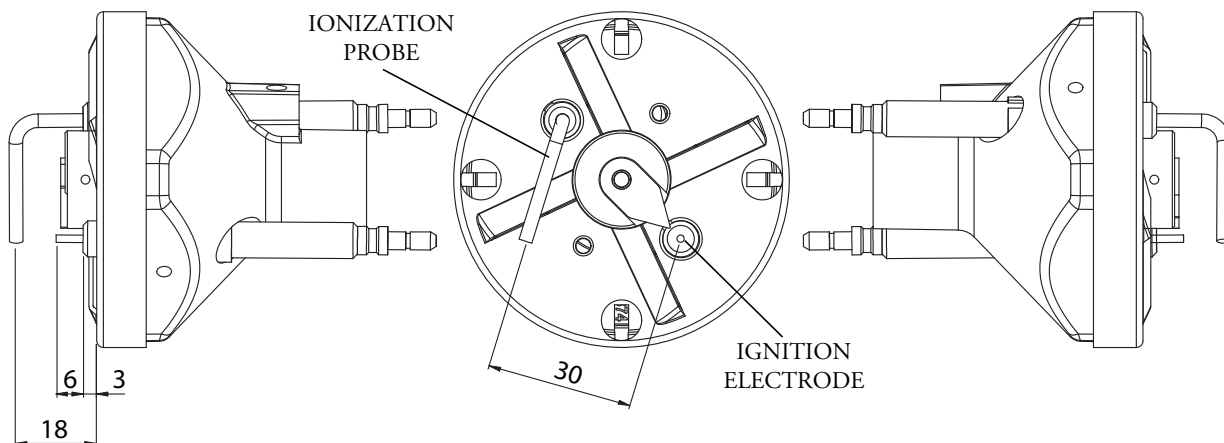

NOTE: For the conversion from Natural Gas into LPG see LBKIT1 manual

MOUNTING TO THE BOILER

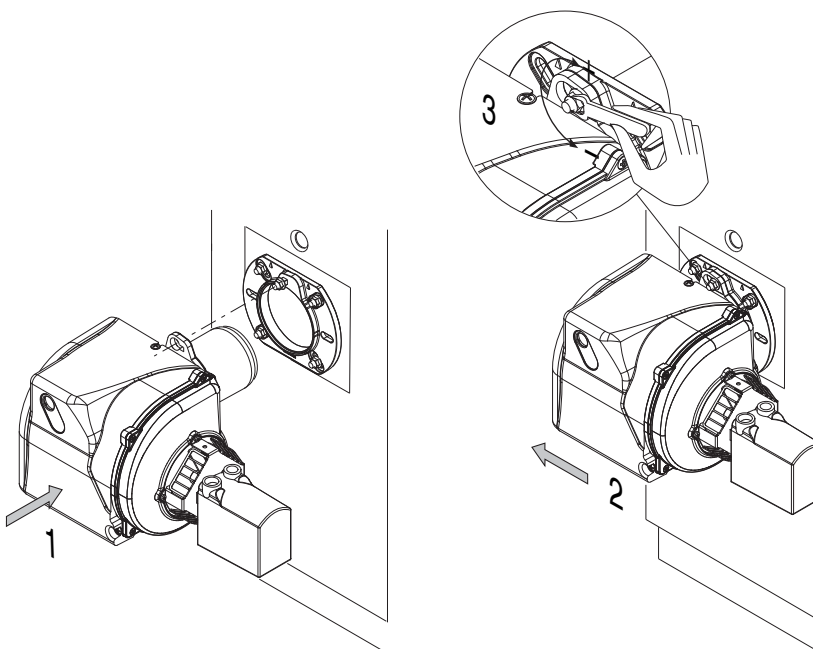

TUBE DISASSEMBLY

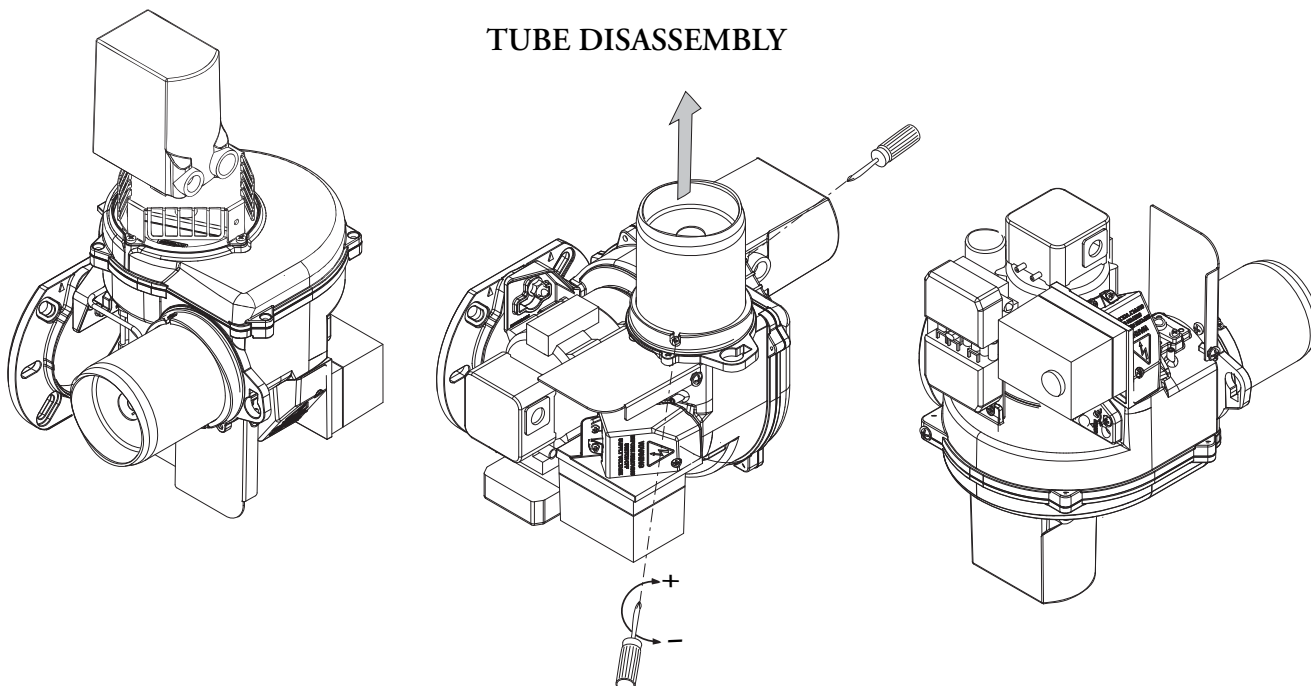

MAINTENANCE**YEARLY INSPECTION**

Periodic inspection of the burner (combustion head, electrodes, etc.) must be carried out by authorised personnel once or twice a year, depending of use. Before carrying out maintenance inspection on the burner, it is advisable to check its general condition and carry out the following operations:

- Disconnect the burner from the power supply (remove the plug).
- Close the gas cock.
- Remove the burner cover, clean the fan and air intake.
- Clean the combustion head and check the position of the electrodes.
- Re-assemble the parts.
- Check the seal on the gas pipe fittings.
- Check the flue.
- Restart the burner.
- Check the combustion parameters ($\text{CO}_2 = 9.5$ to 9.8), ($\text{CO} =$ less than 75 ppm)

BEFORE EACH INTERVENTION CHECK;

- That the system is supplied with power and the burner connected.
- That the gas pressure is correct and the gas cock open.
- That the control systems are correctly connected.

If all these conditions are present, start the burner by pressing the release button. Check the burner cycle.

THE BURNER WILL NOT START;

- Check the switch, thermostats, motor, gas pressure.

THE BURNER PREVENTILATES AND LOCKS AT THE END OF THE CYCLE:

- Check the air pressure and fan.
- Check the air pressure switch.

THE BURNER PREVENTILATES AND WILL NOT IGNITE:

- Check the assembly and position of electrodes.
- Check the ignition cable.
- Check the ignition transformer.
- Check the safety devices.

THE BURNER STARTS UP AND LOCKS AFTER THE SAFETY TIME LIMIT:

- Check that the phase and neutral wires are correctly connected.
- Check the gas electrovalves.
- Check the position of the detection electrode and its connection.
- Check the detection electrode.
- Check the safety devices.

THE BURNER STARTS UP AND LOCKS AFTER RUNNING FOR A FEW MINUTES.

- Check the pressure regulator and the gas filter.
- Check the gas pressure with an ammeter.
- Check the detection value (min $3 \mu\text{A}$ Landis).

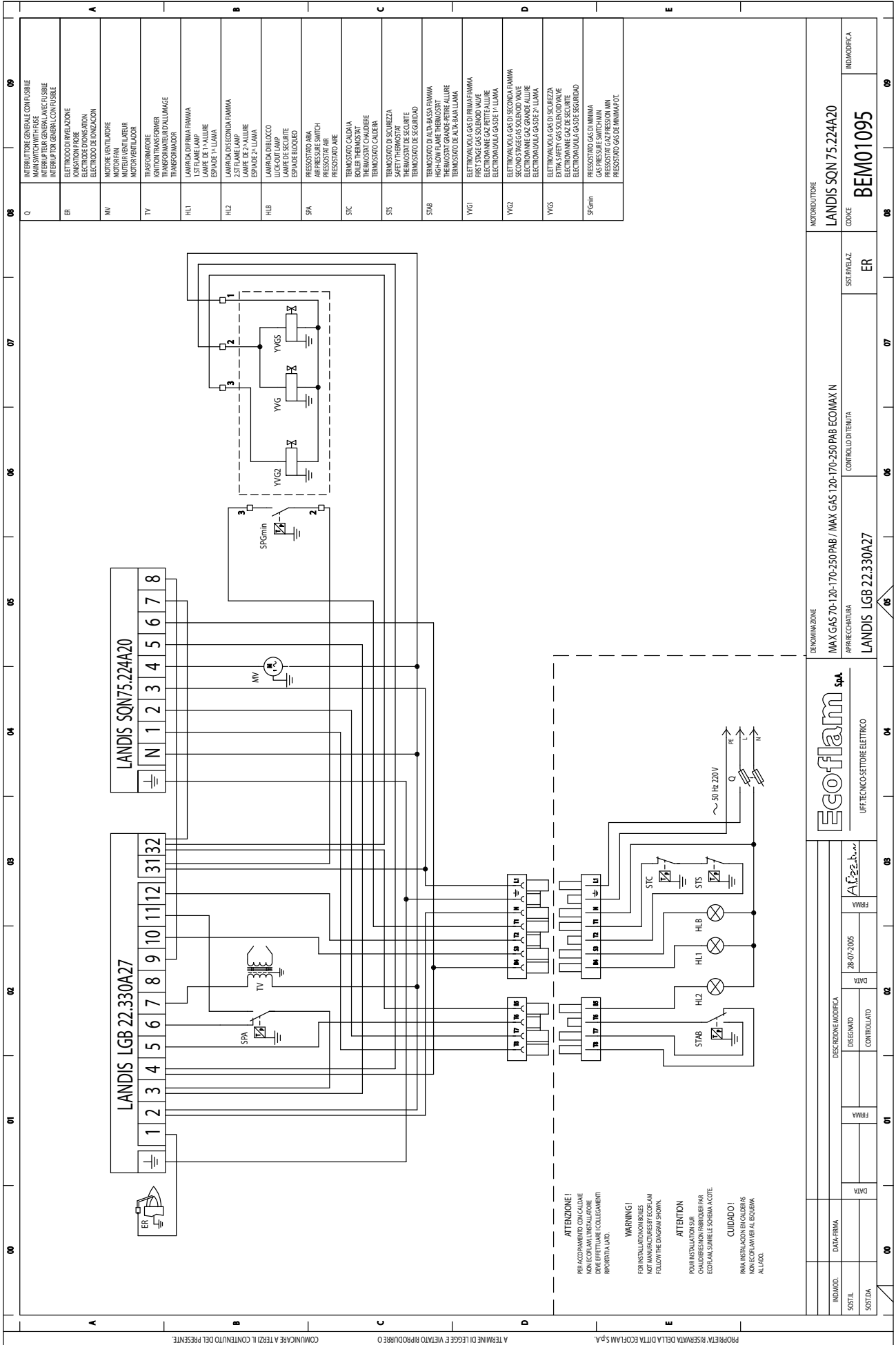

ATTENZIONE!
PER ACCOMPAGNARE CON CALDAIE
NON ECOFLAM L'INSTALLATORE
DEVE EFFETTUARE I COLLEGAMENTI
PROPRIETÀ L.A.D.

WARNING!
FOR INSTALLATION ON BOILERS
NOT MANUFACTURED BY ECOFLAM
FOLLOW THE DIAGRAMS SHOWN
PROPERTY L.A.D.

ATTENTION
POUR INSTALLATION SUR
CALOIFANS NON ECOFLAM
L'INSTALLATEUR DOIT FAIRE
LES RACCORDS SELON LE SCHEMA ACCTE
PROPRIÉTÉ L.A.D.

CUIDADO!
PARA INSTALACION EN CALDERAS
NO ECOFLAM VER EL ESQUEMA
AL LADO.

PROPRIETÀ, RISERVA DELLA DITTA ECOFLAM S.p.A.		A TERMINE DI LEGGE È VIETATO RIPRODURRE O		COMUNICARE A TERZI IL CONTENUTO DEL PRESENTE	
IND. MOD.	DATA FIRMA	DESCRIZIONE MODIFICA	DATA	DATA	DATA
SOST. I.	DATA	DISEGNATO	28-07-2005	FMMA	FMMA
SOST. DA	DATA	CONTROLLATO			
Ecoflam SpA			UFF. TECNICO-SETTORE ELETTRICO		
PERMIAZIONE			IMAX GAS 70-120-170-250 PAB / IMAX GAS 120-170-250 PAB ECOMAX N		
MOTONDIRITTORE			LANDIS SQN 75.224A20		
SOST. RIVELAZ.			ER		
INDIMODIFICA			BEM1095		
CODICE			LANDIS LGB 22.330A27		
CONTROLLO DI TENUTA			IMAX GAS 70-120-170-250 PAB / IMAX GAS 120-170-250 PAB ECOMAX N		
SOST. RIVELAZ.			ER		
INDIMODIFICA			BEM1095		

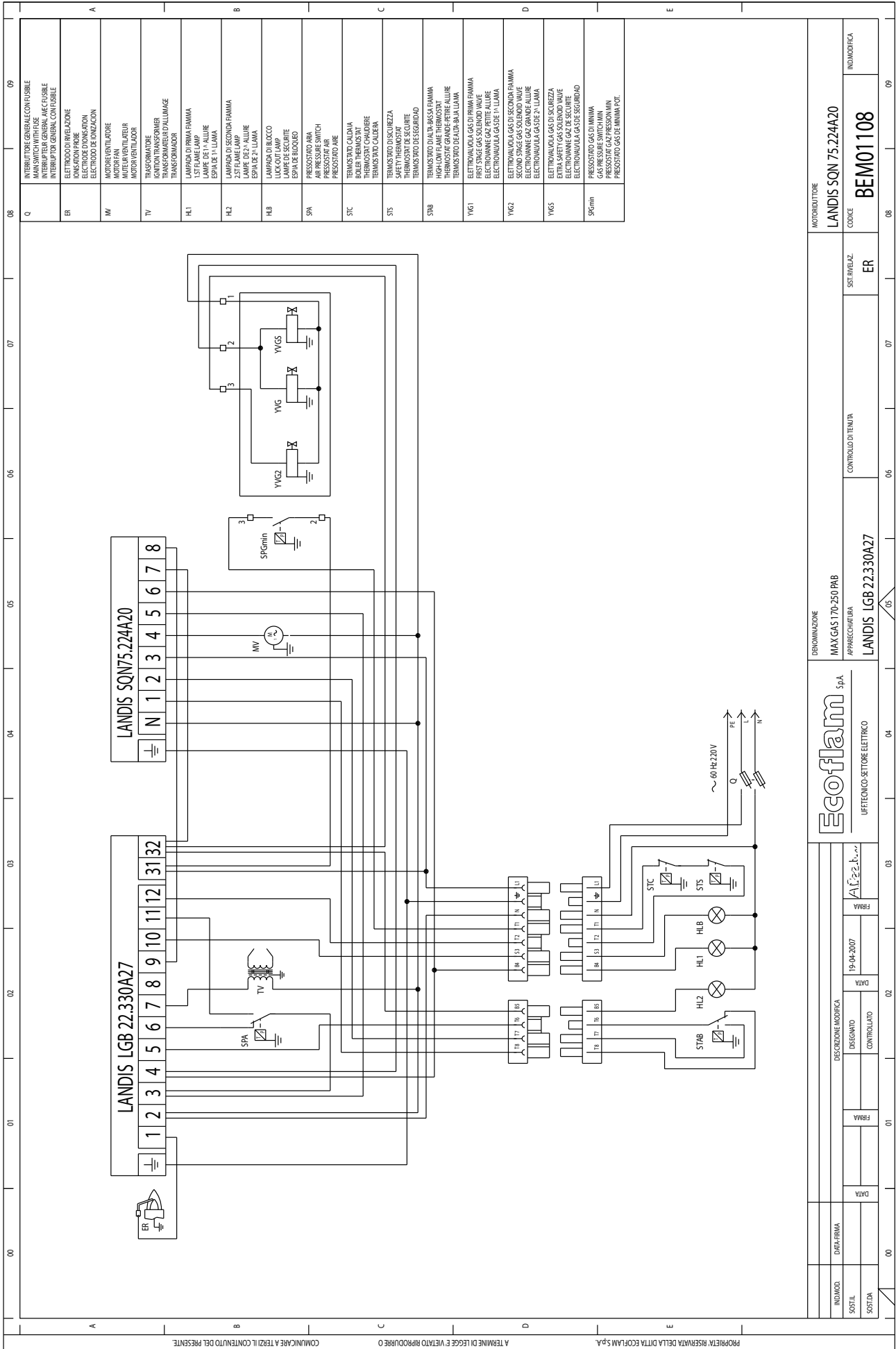

PROPRIETÀ RISERVATA DELLA DITTA ECOFLAM S.p.A. A TERMINI DI LEGGE È VIETATO RIPRODURRE O COMUNICARE A TERZI IL CONTENUTO DEL PRESENTE.

INDIZIO	DATA-FIRMA	DESCRIZIONE MODIFICA	INDICAZIONE
SOST.	19-04-2007	DESIGNATO	MAX GAS 170-250 PAB
SOSTA		CONTROLLATO	APPARECCHIATURA
			LANDIS LGB 22.330A27
			CONTROLLO DI TEMPERA
			SIST. RIRIEZ.
			ER
			LANDIS SQN 75.224A20
			CODICE
			BEM01108
			INDICAZIONE

MAX GAS 70 P AB
MAX GAS 105 P AB
MAX GAS 120 P AB

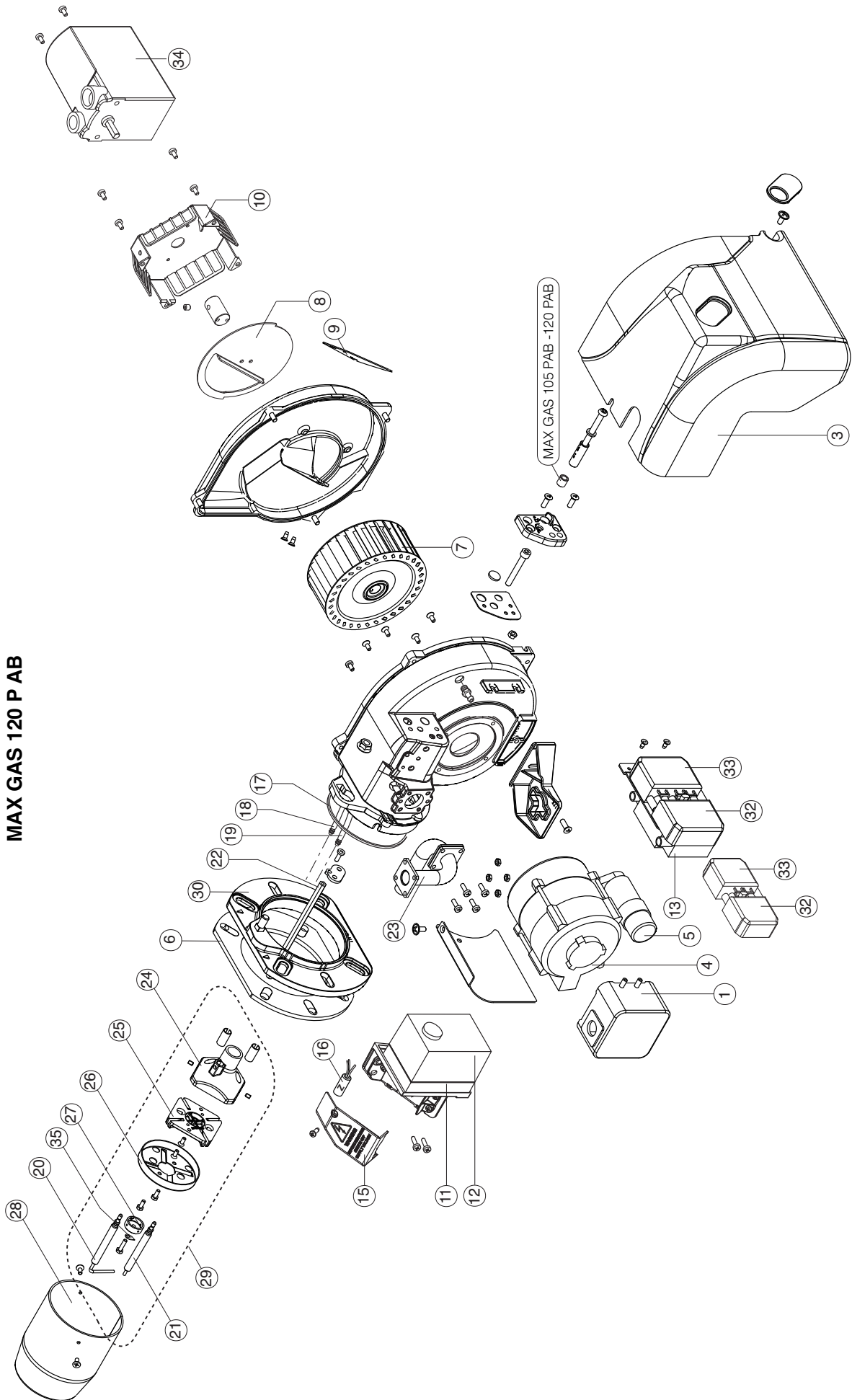

			MAX GAS 70 PAB
N°	DESCRIPTION		code
1	AIR PRESSURE SWITCH	LGW10A2P	65323047
2	AIR INTAKE SET		-
3	BURNER COVER		65320602
4	MOTOR	75 W	65325327
5	CAPACITOR	3 µF AEG	65321857
		5 µF SIMEL	65325038
6	GASKET		65321109
7	FAN	120 x 50	65321770
8	AIR DAMPER		65325146
9	FAN SCOOP		65320621
10	AIR INTAKE		65325147
11	CONTROL BOX BASE	LANDIS	65320092
12	CONTROL BOX	LANDIS LGB 22	65320034
13	IGNITION TRANSFORMER		65323258
14	WIRING TERMINAL BOX		-
15	COVER		65320663
16	ANTIJAMMING FILTER		-
17	ORING		65321061
18	IONIZATION CABLE	TC	65322006
		TL	65322006
19	IGNITION CABLE	TC	65320934
		TL	65320936
20	IONIZATION PROBE		65320905
21	IGNITION ELECTRODE		65325241
22	ROD	TC	65320162
		TL	65320163
23	SUPPORT PIPE	TC	65321528
		TL	65321529
24	FIRING HEAD		65321568
25	HEAD CAP		65321569
26	DIFFUSER		65320761
27	TOOTH	G20-25	65325238
		G30-31	65325239
28	BLAST TUBE	TC	65320311
		TL	65320312
29	INNER ASSEMBLY	G20-25	65322572
		G30-31	65324794
30	FLANGE		65320972
31	CARTER		-
32	PLUG WIELAND	7 pin	65322069
		4 pin	65322065
33	SOCKET WIELAND	7 pin	65322070
		4 pin	65322068
34	AIR DAMPER MOTOR	Landis SQN75.224A21	65106029
35	NEEDLE		65325240

TC = SHORT HEAD TL = LONG HEAD

			MAX GAS 105 PAB	MAX GAS 120 PAB
N°	DESCRIPTION		code	code
1	GAS PRESSURE SWITCH	LGW10A2P	65323047	65323047
2	AIR INTAKE SET		-	-
3	BURNER COVER		65320602	65320602
4	MOTOR	75 W	65325327	65325327
5	CAPACITOR	3 µF AEG	65321857	65321857
		5 µF SIMEL	65325038	65325038
6	GASKET		65321109	65321109
7	FAN	120 x 50	65321770	65321770
8	AIR DAMPER		65325146	65325146
9	FAN SCOOP		65320621	65320621
10	AIR DAMPER MOTOR SUPPORT		65325147	65325147
11	CONTROL BOX BASE	LANDIS	65320092	65320092
12	CONTROL BOX	LANDIS LGB 22	65320034	65320034
13	IGNITION TRANSFORMER		65323258	65323258
14	WIRING TERMINAL BOX		-	-
15	COVER		65320663	65320663
16	ANTI-JAMMING FILTER		-	-
17	ORING		65321061	65321061
18	IONIZATION CABLE	TC	65322006	65322006
		TL	65322006	65322006
19	IGNITION CABLE	TC	65320934	65320934
		TL	65320936	65320936
20	IONIZATION PROBE		65320905	65320905
21	IGNITION ELECTRODE		65325241	65325241
22	ROD	TC	65320164	65320164
		TL	65320165	65320165
23	SUPPORT PIPE	TC	65321530	65321530
		TL	65321531	65321531
24	FIRING HEAD		65321568	65321568
25	HEAD CAP		65321569	65321569
26	DIFFUSER		65320761	65320761
27	TOOTH	G20-25	65325238	65325238
		G30-31	65325239	65325239
28	BLAST TUBE	TC	65320313	65320317
		TL	65320314	65320318
29	INNER ASSEMBLY	G20-25	65322572	65322572
		G30-31	65324794	65324794
30	FLANGE		65320972	65320972
31	CARTER		-	-
32	PLUG WIELAND	7 pin	65322069	65322069
		4 pin	65322065	65322065
33	SOCKET WIELAND	7 pin	65322070	65322070
		4 pin	65322068	65322068
34	AIR DAMPER MOTOR	Landis SQN75.224A21	65106029	65106029
35	NEEDLE		65325240	65325240

TC = SHORT HEAD TL = LONG HEAD

ECOFLAM BRUCIATORI S.p.A. reserves the right to make any adjustments, without prior notice, which it considers necessary or useful to its products, without affecting their main features.

Ecoflam

Ecoflam Bruciatori S.p.A.

via Roma, 64 - 31023 RESANA (TV) - Italy - tel. 0423.719500 - fax 0423.719580
<http://www.ecoflam-burners.com> - e-mail: export@ecoflam-burners.com

"società soggetta alla direzione e al coordinamento della Ariston Thermo S.p.A., via A. Merloni, 45 - 60044 Fabriano (An) CF 01026940427"