

GAS XP60/MCE-LX-EVO

Burners for gas two stages progressive (hi-low flame) or modulating (PID fully modulating) if equipped with addition of optional modulation kit and probe.

They are composed by: fan at high pressurisation at reverse blades and combustion head with adjustment at high efficiency and high flame stability.

Compact overall dimensions and disposition rationalized of the components with accessibility facilitated for the operations of setting and maintenance.

Available in the versions METHANE (natural gas).

Gas train complete of working valve with flow adjustment, safety valve, minimum gas pressure switch and gas filter.

Complete of flange and gasket for installation on generator.

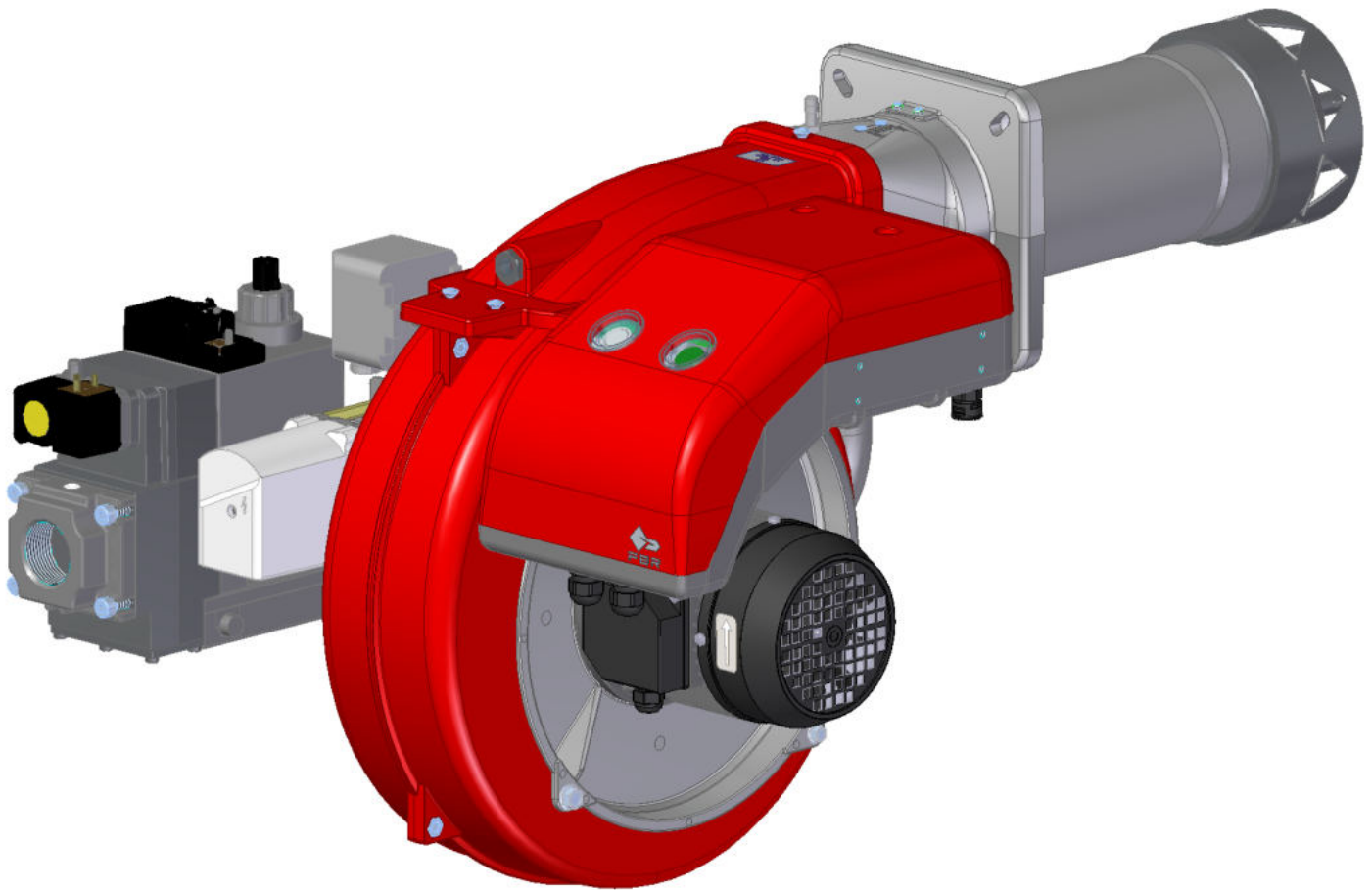

Fig. 1 GAS XP60/MCE-LX-EVO

TECHNICAL DATA AND OPERATING RANGE DIAGRAM GAS XP60/MCE-LX-EVO

MODEL	GAS XP60/MCE-LX-EVO	
Thermal power min. 1°st. / min. 2°st. - max. 2°st. *	[Mcal/h]	101/241-542
Thermal power min. 1°st. / min. 2°st. - max. 2°st. *	[kW]	117/280-630
Gas flow G20 (NATURAL GAS) min. 1°st. / min. 2°st. - max. 2°st. *	[Nm³/h]	11.7/28-63.3
Fuel: NATURAL GAS (second family)		
Fuel category:	I2R,I2H,I2L,I2E,I2E+,I2Er,I2ELL,I2E(R)	
NOx**	[mg/kWh]	< 80: class 3 (EN 676)
Intermittent working operation (min. 1 stop every 24 hours) two stages progressive or modulating		
Environmental conditions operation / storage:	-15...+40°C / -20...+70°C, umidità rel. max. 80%	
Max. temperature combustion air	[°C]	60
Minimum pressure gas train D1"-S NATURAL GAS ***	[mbar]	126
Minimum pressure gas train D1"1/4-S NATURAL GAS ***	[mbar]	67
Minimum pressure gas train D1"1/2-S NATURAL GAS ***	[mbar]	28
Maximum pressure at the entry of valves (Pe. max)	[mbar]	360
Nominal electric power	[W]	700
Fan motor	[W]	550
Nominal motor current absorption	[A]	1.4
Nominal auxiliary absorption	[A]	0.5
Power supply:	3~400V, 1N~230V - 50Hz	
Electric protection degree:	IP 40	
Noisiness **** min. - max.	[dB(A)]	69-72
Burner weight *****	[kg]	

* Reference conditions: Environment temperature 20°C - Barometric pressure 1013 mbars - Altitude 0 metre (sea level).

** To obtain the NOx emissions so reduced as declared, the burner must be coupled to boilers designed for this purpose: boilers with three smoke passes, condensation and any direct discharge generator with a thermal load no higher than 1.1 MW / m³.

*** Minimal feeding-gas pressure to the gas train to get the maximum power of the burner, considering counter-pressure in combustion chamber of value 0 (zero).

**** Measured sonorous pressure in the laboratory combustion, with functional burner on beta boiler to 1 metre of distance (UNI EN ISO 3746 - Class 3 control method - The measured sound pressure tolerance can be assumed to be ± 1 [dB (A)]).

***** For burner with long head add 1 kg to the weight.

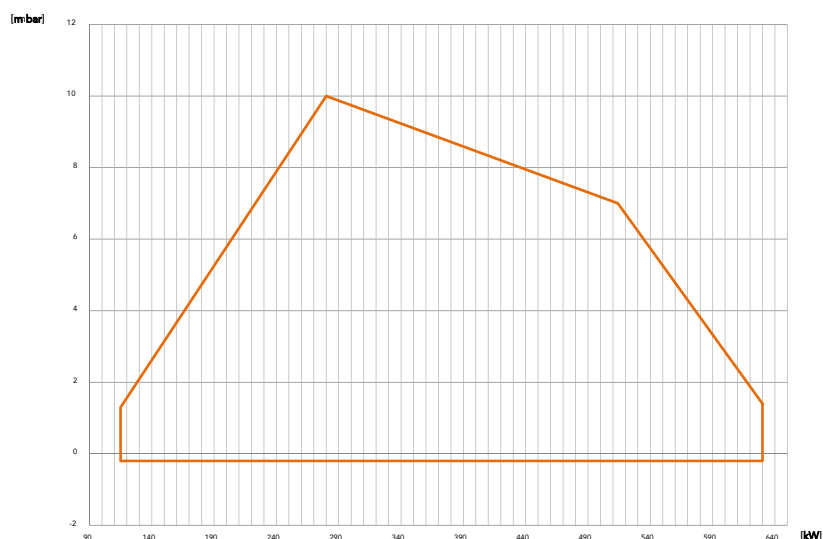

Fig. 2 X = Thermal power Y = Pression in the combustion chamber

The firing rates has been obtained based on test boilers in accordance with EN267 standards and are indicative of matching the burner to the boiler. For the correct operation of the burner, combustion chamber dimensions must be in accordance with current regulation. In case of non-compliance, contact the manufacturer.

DIMENSIONS [MM]

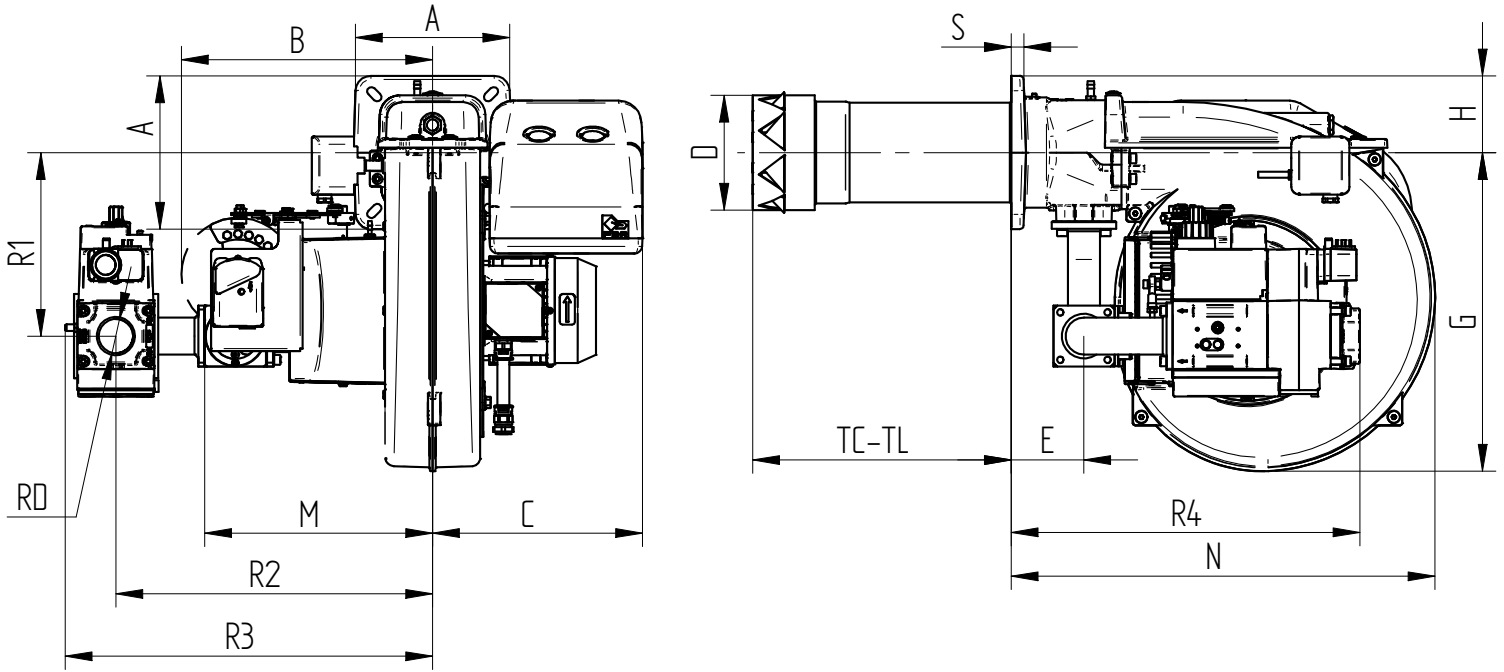
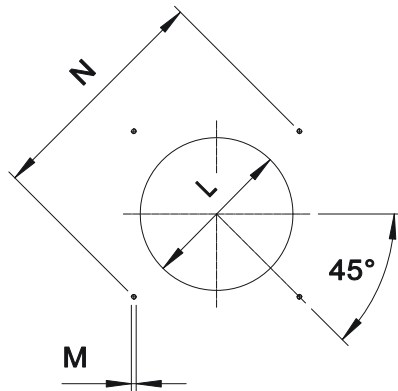

Fig. 3 Dimensions GAS XP60/MCE-LX-EVO

MODEL	A	B	C	D	E	F	H	M	N	S	R1	R2	R3	R4	RD
GAS XP60/MCE-LX-EVO - D1"-S	200	330	275	150	99	417	100	298	558	20	240	414	472	445	Rp 1
GAS XP60/MCE-LX-EVO - D1"1/4-S	200	330	275	150	99	417	100	298	558	20	240	414	472	445	Rp 1 1/4
GAS XP60/MCE-LX-EVO - D1"1/2-S	200	330	275	150	99	417	100	298	558	20	240	414	480	460	Rp 1 1/2

BOILER PLATE



* Suggested dimension of connection between burner and generator.

Fig. 4 Boiler plate

MODEL		L min	L *	L max	M	N min	N *	N max
GAS XP60/MCE-LX-EVO	mm	160	160	180	M10	205	205	226

FLAME TUBE LENGTH

Flame tube length must be selected based on the specifications supplied by boiler manufacturer and, in any case, it must be greater than the thickness of the boiler door included its insulation.

In case of boilers with flame inversion or front flue combustion chambers, it is necessary to insulate the area between the flame tube and front door with refractory material. This protection material must not impede flame tube extraction.

MODEL		TC	TL **
GAS XP60/MCE-LX-EVO	mm	250	335

** For different flame lengths, please contact our Technical-Sales Department.

BURNER SIGNAL DESCRIPTION

In the picture below there are indicated all the signalation present on the burner:

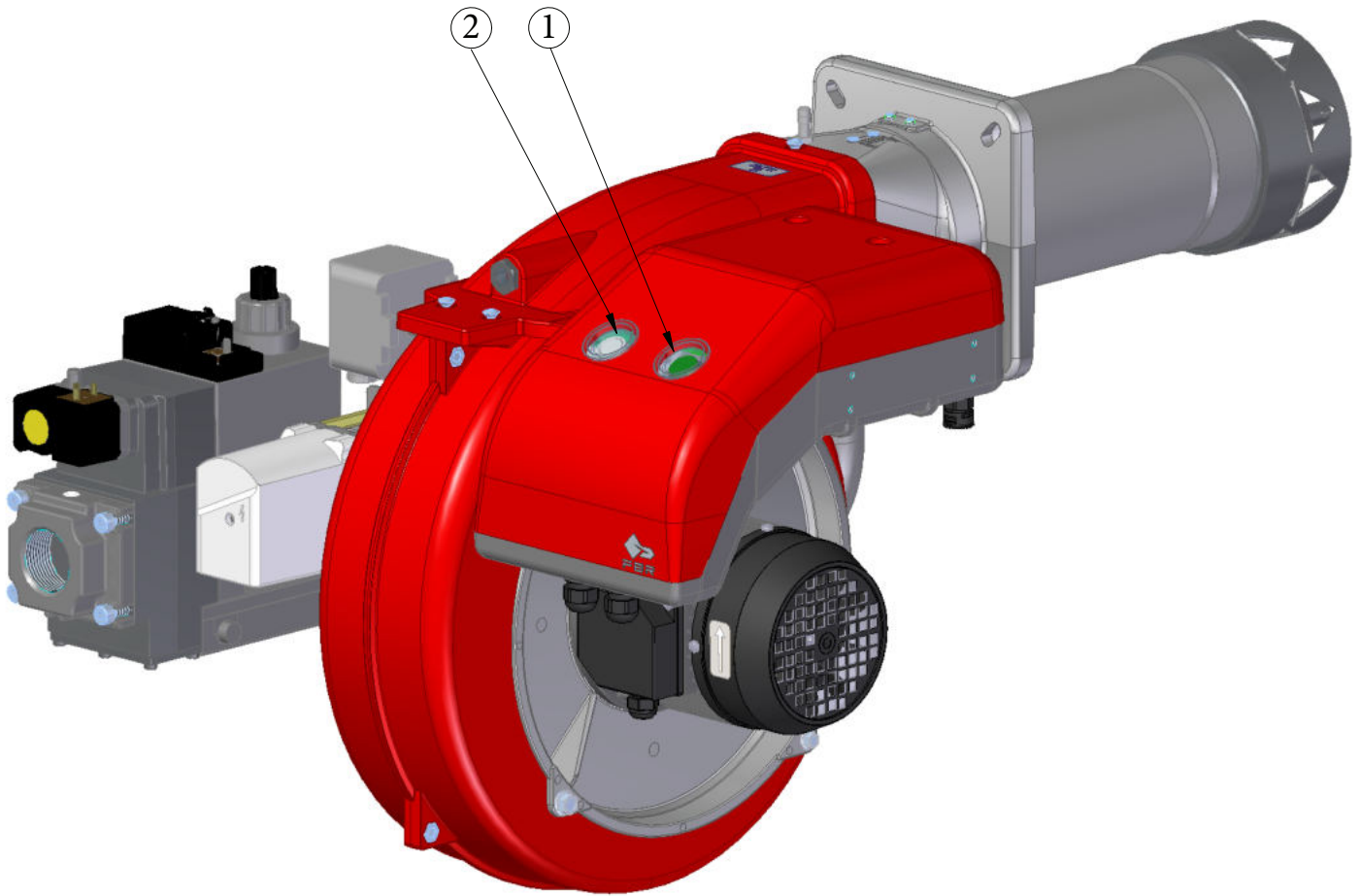

Fig. 5 Burner signal description

LEGEND

- 1) ON/OFF button
- 2) Reset from lockout button + status lamp

💡 The multicolor signal lamp in the lockout reset button (pos.2) is the key indicating element for visual diagnostics and interface diagnostics.

In normal operation, the different operating states are indicated in the form of color codes; please refer to electrical device handbook supplied with the present instructions.

💡 After a non-alterable lockout, the red signal lamp in the lockout reset button (pos.2) lights up. By pressing the lockout reset button (pos.2) for more than 3 seconds, the visual diagnostics of the cause of fault can be activated; please refer to electrical device handbook supplied with the present instructions.

For close the diagnostics mode and for switch on the burner again, it is necessary to reset the burner control. Press the lockout reset button (pos.2) for about 1 second (<3 seconds).

💡 After a non-alterable lockout, the red signal lamp in the lockout reset button (pos.2) lights up. For reset the control box press the lockout reset button (pos.2) for about 1 second (<3 seconds).

PRODUCT SPECIFICATION

SHORT DESCRIPTION

Progressive two-stage gas burners (hi-low flame) or modulating (fully modulating PID) if equipped with modulation kit and probe with low emissions CE 676 class 3 (NO_x <80 mg / kWh).

DETAILED SPECIFICATION

Progressive (hi-low flame) or modulating (PID fully modulating) gas burner if equipped with additional modulation kit and probe; with low emissions CE 676 class 3 certified (NO_x <80 mg / kWh); composed of:

- Fan at high pressurisation at reverse blades;
- Combustion head with adjustment at high performance and elevated flame stability equipped with inox steel blast tube and steel flame disc;
- Flange and insulating gasket for fixing at boiler;
- Three-phase power supply;
- Safety air pressure switch to stop the burner in lock-out in case of failed or anomalous fan operation;
- Gas train with safety valve class A, adjustment valve class A;
- Ionisation probe for flame detection;
- IP 40 electric protection level;
- Spherical gas valve servo-controlled; progressive start and free way passage with total opening;
- Servomotor for air shutter and for the spherical gas valve;
- Moving shutter with total closure when idle in order to reduce at the least energy losses related to boiler cooling down;
- Easy extraction of combustion head without get off the burners by boiler;
- Set up for the additional specific kit that transforms burner operation as modulating i.e. the modulating kit allows to supply any power between the minimum and the maximum value based on instantaneous loading request.

CONFORMING TO:

- CE rules;
- 2014/30/UE Directive E.M.C.;
- 2014/35/UE Directive L.V.;
- 2006/42/CE - 2006/42/EG - 2006/42/EC Directive M.D.;
- GAS 2016/426/UE Regulation;
- Reference rules: EN676 (gas) – EN 746-2 (industrial thermoprocessing equipment).

STANDARD EQUIPMENT

- Isomart gasket;
- Flange with insulating gasket;
- Burner nameplate;
- Warranty;
- Instruction handbook for installation, use and maintenance.

OPTIONAL

- Power modulating kits for temperatures;
- Power modulating kits for pressures;
- Temperature probe 0°C-400°C (PT 100 a 0° C);
- Temperature probe 0°C-1200°C (K probe);
- Pressure probe 0-3 bar, 0-6 bar. 0-16 bar, 0-20 bar, 0-30 bar;
- Noise protection;
- Antivibration couplings;
- Handle gas taps.