

PROGRESSIVE GAS BURNERS

Ecoflam

CE



BLU TS 2000.1 PR



420010484200

420010484200

21.05.2012

TECHNICAL DATA

MODEL		BLU TS 2000.1 PR
Thermal power max.	kW	2150
	kcal/h	1.853.450
Thermal power min.	kW	414
	kcal/h	356.900
Min. natural gas pressure	mbar	40÷300
Min. LPG gas pressure	mbar	37÷150
Fuel :	L.C.V. Natural gas = 35,9 MJ/Nm ³ = 8.570 kcal/Nm ³ L.C.V. LPG =22.260 kcal / Nm ³	

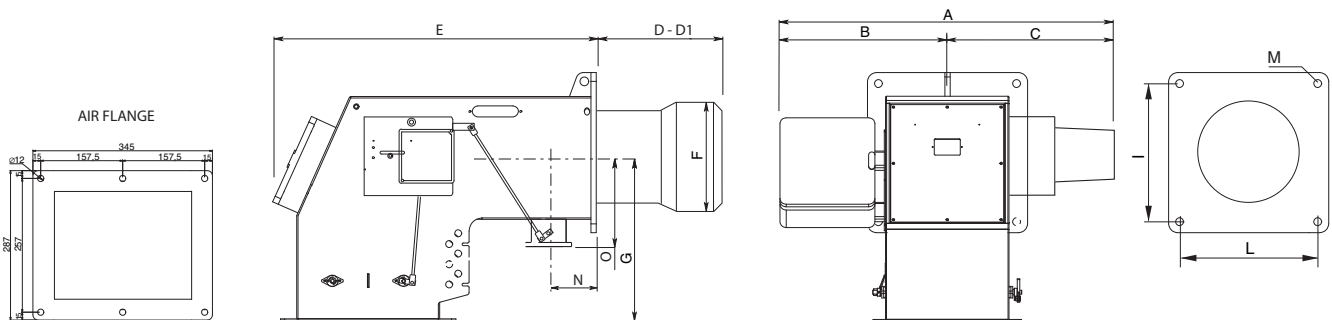
OVERALL DIMENSIONS

MODEL	A	B	C	D	D1	E	F	G	I	L	M	N	O
BLU TS 2000.1 PR	922	444	478	345	545	620	270	355	270	270	M16	125	250

D = Short head D1 = Long head

ELECTRICAL CONNECTIONS

All burners factory tested at 400 V 50 Hz three-phase for motors and 230 V 50 Hz monophase with neutral for auxiliary equipment. If mains supply is 230 V 50 Hz threephase without neutral, change position of connectors on burner as in fig. Protect burner supply line with safety fuses and any other devices required by safety standards obtaining in the country in question.

CONNECTION TO THE GAS PIPELINE

Once connected the burner to the gas pipeline, it is necessary to control that this last is perfectly sealed. Also verify that the chimney is not obstructed. Open the gas cock and carefully bleed the piping through the pressure gauge connector, then check the pressure value through a suitable gauge. Power on the system and adjust the thermostats to the desired temperature. When thermostats close, the sealing control device runs a seal test of valves; at the end of the test the burner will be enabled to run the start-up sequence.

START UP OF THE BURNER

Once connected the burner to the gas pipe make sure that there are no leakages. Air bleed the pipe through the pressure gauge fixing point and check the pressure with a pressure gauge. Turn the thermostats to the desired temperature.

PRELIMINARY CHECKS

- Before starting up the boiler check the following: - gas type and feed pressure; - gas valves closed; - the seals in the pipe fittings; - gas pipe breather and input pressure; - that the cable complies with the diagram and the phase and neutral wires correspond; - that the burner shuts down when the boiler thermostat opens;- the seal of the boiler furnace which prevents air from entering; - the seal on the flue-boiler pipe fitting; - the condition of the flue (sealed, free from blockage, etc).If all these conditions are present, start the burner. The control device starts the motor to carry out prewashing of the combustion chamber. During this prewash period (about 30 seconds) the device checks that air pressure is correct via the air pressure switch. At the end, it supplies power to the transformer and opens the gas valves. The flame must be lit and stabilize within 3 seconds, which is the device's safety time limit. Check to ensure the flame is lit before placing any control instrument in the flue. Adjust and check the gas flow necessary for the boiler at the meter. Adjust the air flow according to the gas flow to obtain correct combustion.

ADJUSTING THE COMBUSTION PROCESS

IMPORTANT: to obtain the right adjustment of the combustion and thermal capacity it is important to analyze the reducts of combustion with the aid of suitable instruments. The combustion and thermal capacity adjustment is done simultaneously, together with the analysis of the products of combustion, making sure that the measured values are suitable and that they comply with current safety standards. On this matter, please refer to the table and figure below.

THESE OPERATIONS MUST BE DONE BY PROFESSIONALLY-QUALIFIED TECHNICIANS.

	Natural Gas
CO ₂	9,6%
CO	<50 ppm
	L.P.G.
CO ₂	11,7%
CO	<50 ppm

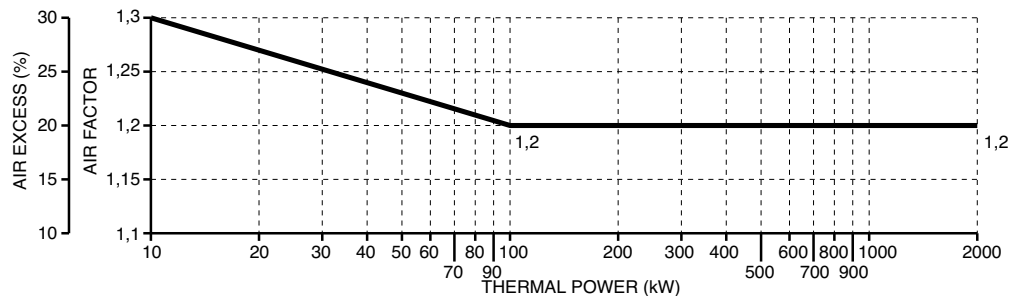

LANDIS LGB 22 UP-CYCLE

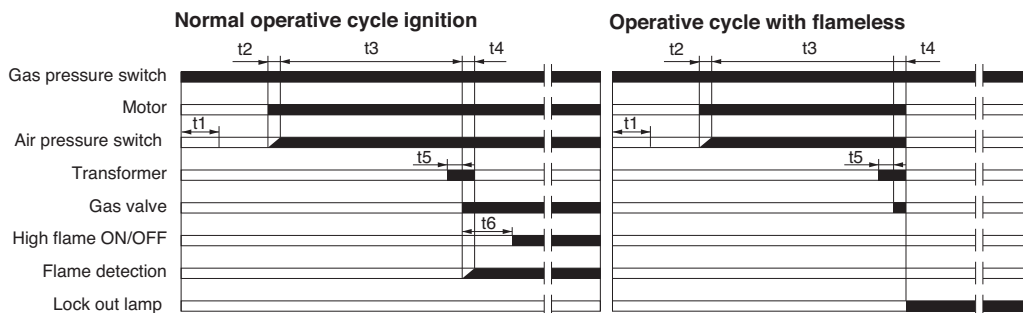

Description	⌚
t1 pressure switch control time-out	9"
t2 time-out for air pressure confirmation	3"
t3 prewashing time	30"
t4 safety time	3"
t5 preignition time	3"
t6 time-out to enable fuel 2nd valve	8"

The control box starts the burner fan, to carry out the prepurging of the combustion chamber, and checks the vent air pressure through the air pressure switch. At the end of prepurging, the ignition transformer cuts-in and generates a spark between the electrodes. At the same time the two gas valves open (Vs safety valve and VI Low flame working valve). The total safety, in case of missed ignition or casual burner's flame-out, is granted by a ionisation probe which cuts-in and sets the burner shut-down within the safety time. In case of gas lack or a major pressure drop, the minimum air pressure switch shuts down the burner.

LANDIS & STAEFA SQN 30 251A2700 AIR DAMPER MOTOR

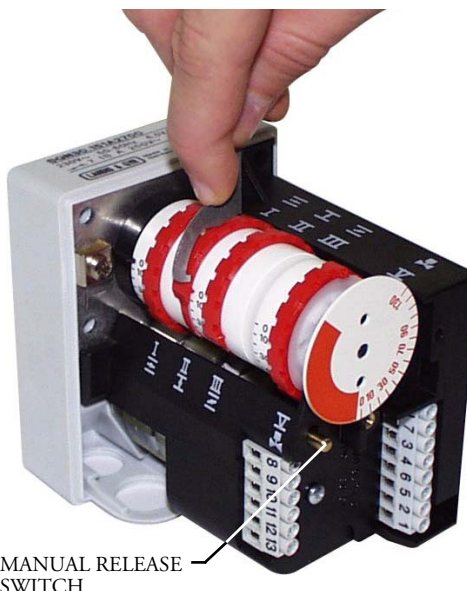

Remove cover to gain access to the adjusting cams. The cams are to be adjusted through the suitable key provided for. Description:

- I - Limit switch for air damper "High Flame" position adjustment (Max. power)
- II - Limit switch for the air damper position at burner's shut down
- III - Limit switch for air damper "Low Flame" position adjustment (Min. power)
- V - Limit switch "NOT USED".

AIR ADJUSTMENT

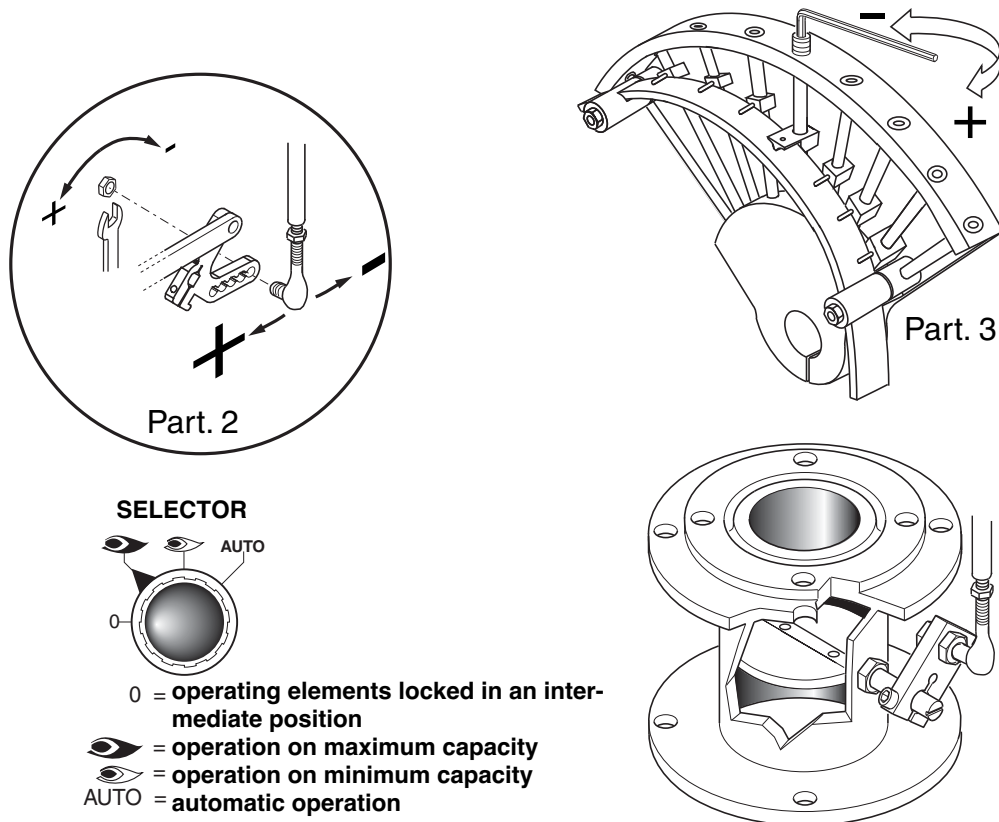

ADJUSTING THE MINIMUM CAPACITY OF THE BURNER – AIR and GAS

Position the selector placed on the control panel on position 2 and proceed as follows:

Adjust the minimum gas flow rate using a suitable wrench, turn the butterfly valve until you reach the correct gas flow, as established by analyzing the combustion process.

ADJUSTING THE MAXIMUM CAPACITY OF THE GAS

Position the selector, situated on the control panel, on position 1 and proceed as follows:

Adjusting the maximum gas flow rate (see figure on solenoid valve adjustments) or adjust the gas pressure in the governor.

ADJUSTING THE MAXIMUM AIR FLOW RATE

Adjusting the maximum air flow rate (see figure, detail 2). Loosen the nut holding the air damper transmission rod; The correct air flow as established by analyzing the combustion process.

ADJUSTING THE INTERMEDIATE BURNER CAPACITY

Using the selector, start the servomotor (closing or opening) and position on 0 to stop the stroke; the adjustment is made as outlined below. Repeat the operation for the other cam points.

Adjustment the intermediate gas flow rates (see figure, detail 3): - using a suitable Allen wrench, change the position of the cam guide blade; if you screw it down, the flow rate is reduced; if you unscrew it, the flow rate increases.

CALCULATING THE BURNER CAPACITY

To calculate the burner's capacity in kW, proceed as follows: Check the gas flow rate (in liters) on the counter and the time of the reading in seconds.

Proceed with the calculation using the following : $\frac{e}{\text{sec}} \times f = \text{kW}$

e	=	Litres gas
sec	=	Time in second
f	[G20 = 34,02
		G30 = 116
		G31 = 88

COMBUSTION ADJUSTMENT

WARNING: In order to have a correct combustion and thermal output adjustments, these must be carried out together with a combustion analysis, to be executed through suitable devices, taking care that the values are the correct ones and are in accordance with the local safety regulations. The adjustments must be carried out by qualified and skilled technicians authorised by Ecoflam Bruciatori S.p.A..

SETTING THE FIRING HEAD

The firing head position adjustment is made in order to obtain the best combustion efficiency. When used with minimum outputs the firing head is adjusted in rear position. With high output, the firing head is adjusted in forward position. **Adjustment:** - Loosen screw A through a suitable Allen key.- By a screwdriver act on the hex. head screw B until is reached the desired position. - Tighten screw A

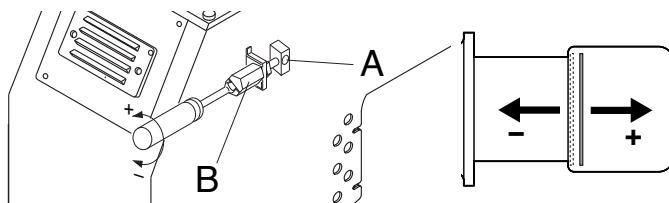

POSITION OF ELECTRODES

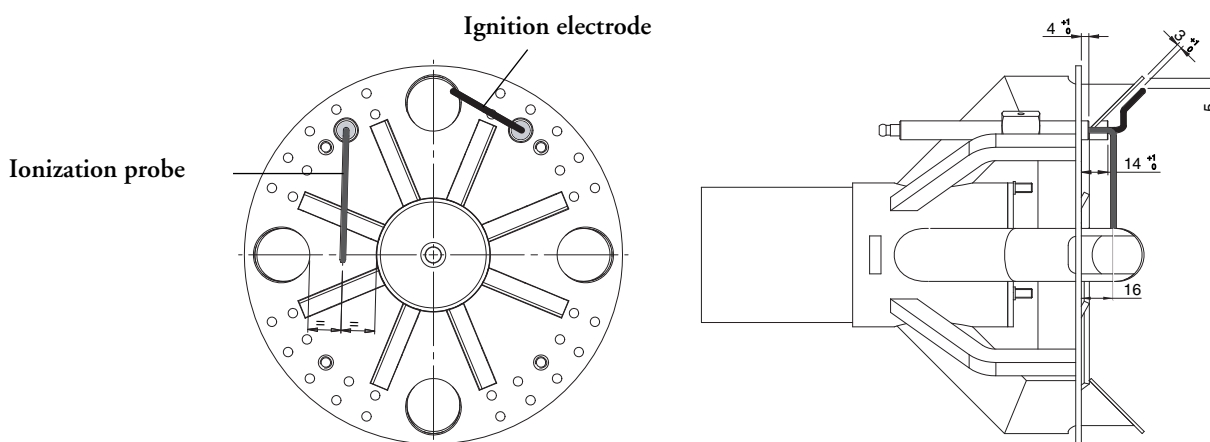

ADJUSTMENT OF GAS MINIMUM PRESSURE SWITCH

Unscrew off and remove cover M. - Set regulator N to a value equal to 60% of gas nominal feed pressure (i.e. for nat. gas nom. pressure = 20 mbar, set regulator to a value of 12 mbar; for L.P.G. nom. pressure of G30/G31- 30/37 mbar, set regulator to a value of 18 mbar).Screw up cover M

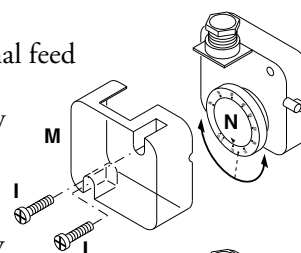

ADJUSTMENT OF THE AIR PRESSURE SWITCH

Unscrew screws A and B and remove cover C.- Set the pressure switch to the minimum by turning regulator D to position 1.

- Start the burner and keep in low flame running, while checking that combustion is correct. Through a small cardboard, progressively obstruct the air intake until to obtain a CO₂ increase of 0,5÷0,8% or else, if a pressure gauge is available, connected to pressure port E, until reaching a pressure drop of 1 mbar (10 mm of W.G.). - Slowly increase the adjustment value of the air pressure switch until to have the burner lockout. Remove the obstruction from the air intake, screw on the cover C and start the burner by pressing the control box rearm button.

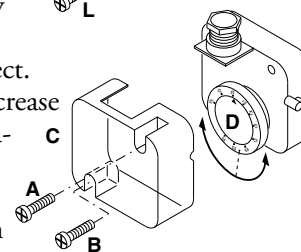

IONIZATION CURRENT

The minimum current necessary to operate the control-box is 3 μA (Landis LGB22). When the measurement of the current is required it is necessary to disconnect the lead to the probe and insert in its place a microammeter for direct current (see fig. under).

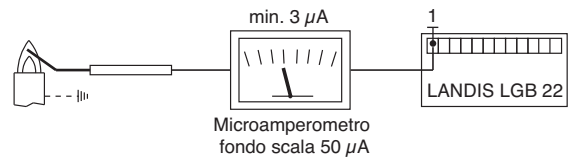

MAINTENANCE

YEARLY INSPECTION

Periodic inspection of the burner (combustion head, electrodes, etc.) must be carried out by authorised personnel once or twice a year, depending of use.

Before carrying out maintenance inspection on the burner, it is advisable to check its general condition and carry out the following operations:

- Disconnect the burner from the power supply (remove the plug).
- Close the gas cock.
- Remove the burner cover, clean the fan and air intake.
- Clean the combustion head and check the position of the electrodes.
- Re-assemble the parts.
- Check the seal on the gas pipe fittings.
- Check the flue.
- Restart the burner.
- Check the combustion parameters ($\text{CO}_2 = 9.5$ to 9.8), ($\text{O} =$ less than 75 ppm).

BEFORE EACH INTERVENTION CHECK:

- That the system is supplied with power and the burner connected.
- That the gas pressure is correct and the gas cock open.
- That the control systems are correctly connected.

If all these conditions are present, start the burner by pressing the release button. Check the burner cycle.

THE BURNER WILL NOT START:

- Check the switch, thermostats, motor, gas pressure.

THE BURNER PREVENTILATES AND LOCKS AT THE END OF THE CYCLE:

- Check the air pressure and fan.
- Check the air pressure switch.

THE BURNER PREVENTILATES AND WILL NOT IGNITE:

- Check the assembly and position of electrodes.
- Check the ignition cable.
- Check the ignition transformer.
- Check the safety devices.

THE BURNER STARTS UP AND LOCKS AFTER THE SAFETY TIME LIMIT:

- Check that the phase and neutral wires are correctly connected.
- Check the gas electrovalves.
- Check the position of the detection electrode and its connection.
- Check the detection electrode.
- Check the safety devices.

THE BURNER STARTS UP AND LOCKS AFTER RUNNING FOR A FEW MINUTES:

- Check the pressure regulator and the gas filter.
- Check the gas pressure with an ammeter.
- Check the detection value (min $3 \mu\text{A}$ LGB22).

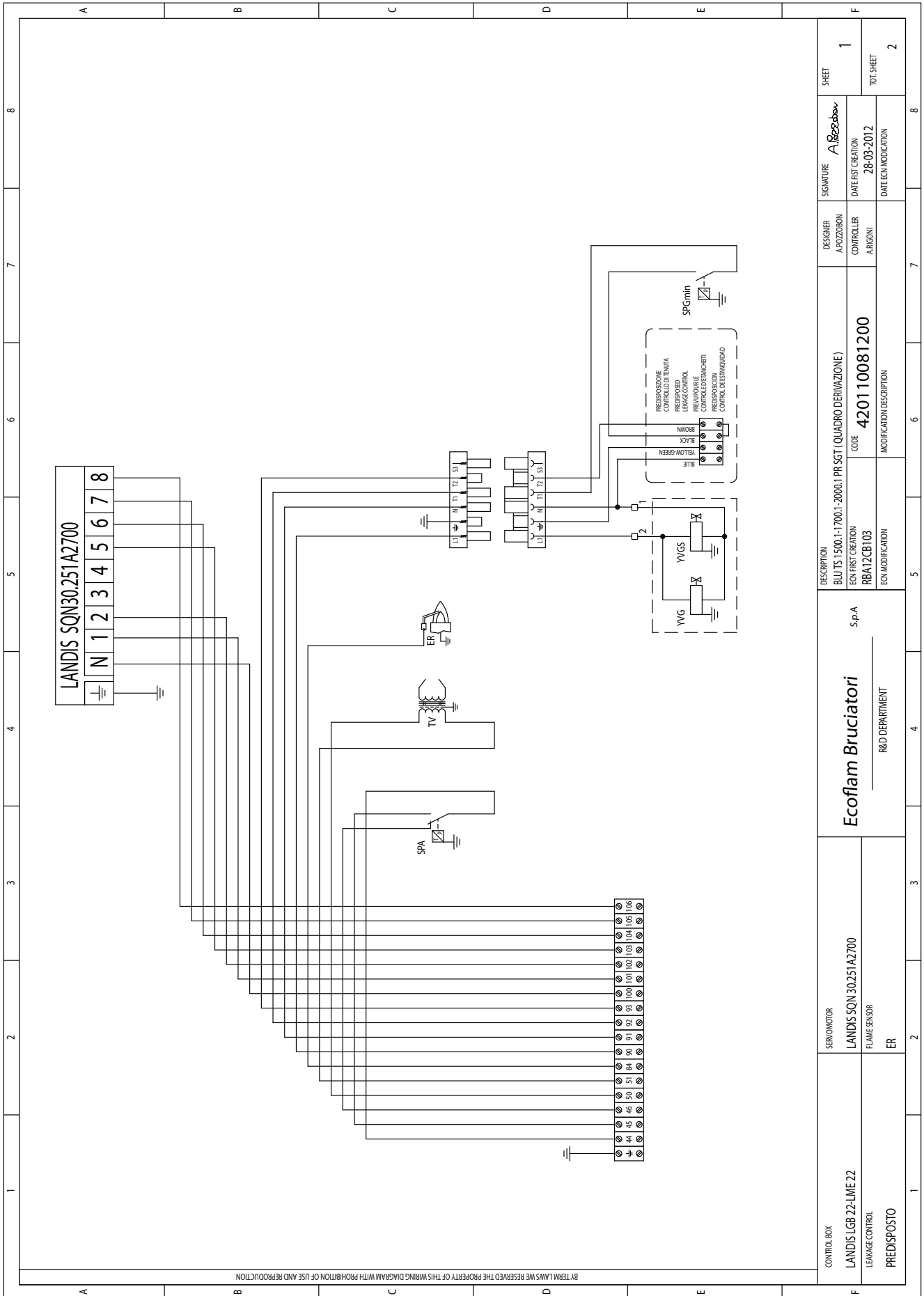

BY TERM LAMS WE RESERVED THE PROPERTY OF THIS WIRING DIAGRAM WITH PROHIBITION OF USE AND REPRODUCTION

CONTROL BOX LANDIS LGB 22-LIME 22	SERVO MOTOR LANDIS SQN 30.251 A2700	Ecoflam Bruciatori S.p.A R&D DEPARTMENT		DESCRIPTION BLU TS 1500.1-1700.1-2000.1 PR SGT (QUADRO DERIVAZIONE)	DESIGNER APPOZZOBN	SIGNATURE A. Pozzobon	SHEET 1
LEAKAGE CONTROL PREDISPOSTO	FLAME SENSOR ER			EON FIRST CREATION RBA12CB103	CONTROLLER ARCONI	DATE FIRST CREATION 28-03-2012	TOT. SHEET 2
				CODE 420110081200	MODIFICATION DESCRIPTION		

BLU TS 2000.1 PR

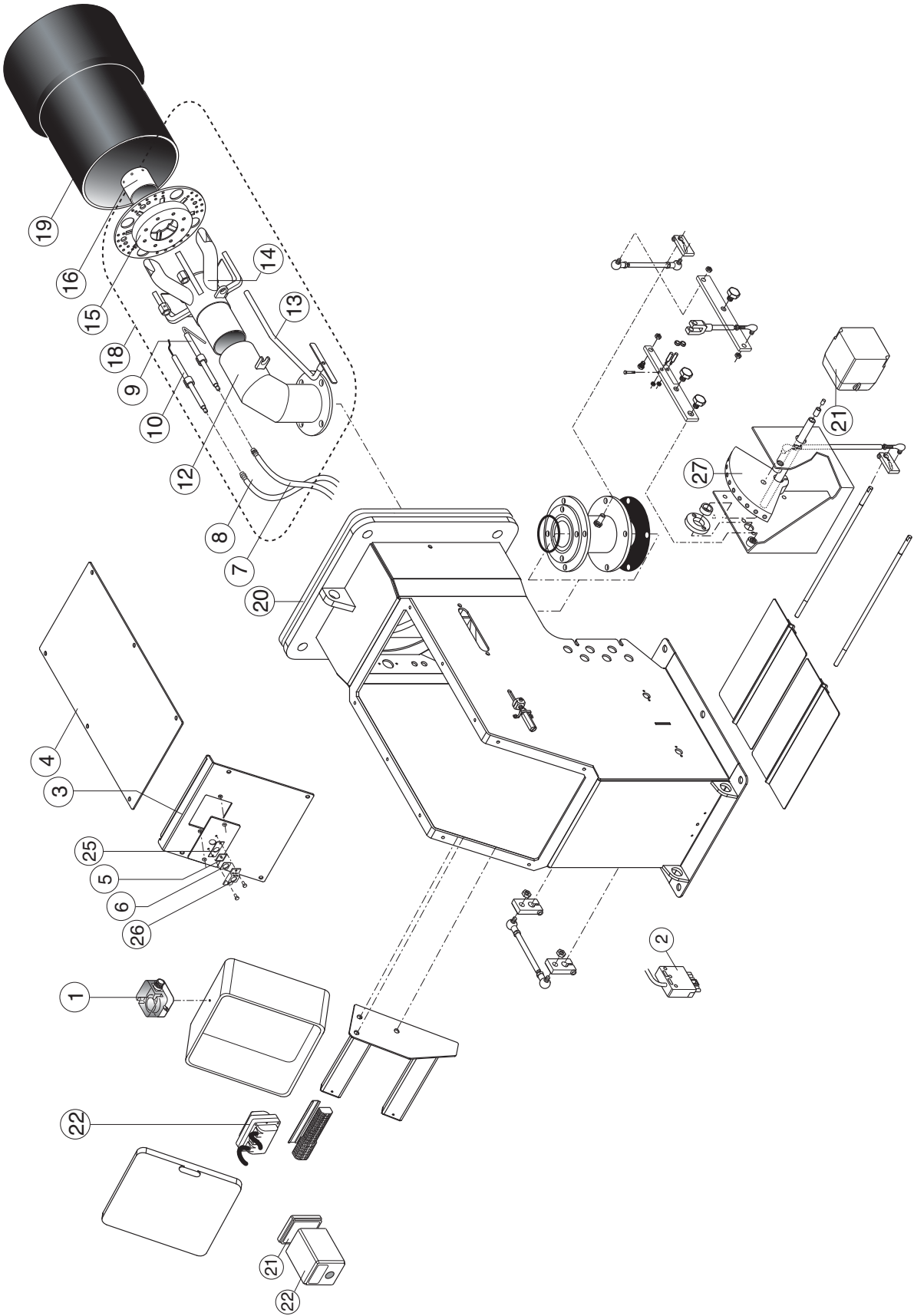

N° DESCRIPTION		BLU TS 2000.1 PR
1 - AIR PRESSURE SWITCH	LGW10A2P	65323047
2 - WIELAND PLUG		65322072
3 - DOWN COVER		65324969
4 - UP COVER		65324970
5 - GLASS		65321883
6 - GASKET	28x28	65321948
7 - IGNITION CABLE		65322003
8 - IONIZATION PROBE		65322003
9 - IGNITION ELECTRODE		65320903
10- IONIZATION PROBE		65320892
11- GAS PIPE		-
12- GAS PIPE SUPPORT	TC	65321667
	TL	
13- ROD	TC	65320244
	TL	
14- FIRING HEAD		65321669
15- DISC		65320743
16- TOOTH		65321606
17- DIFFUSER		-
18- INNER ASSEMBLY		
19- BLAST TUBE	TC	65320436
	TL	
20 - GASKET ISOMART		65324971
21- AIR DAMPER MOTOR	SQN30.251A2700	65322896
22- IGNITION TRANSFORMER	COFI TRS820P	65323227
23- CONTROL BOX BASE	LANDIS	65320092
24- CONTROL BOX	LANDIS LGB22.330A2EM	65320034
25- GLASS	30x50	65321949
26- GLASS COVER		65321884
27- GAS CAM GROUP		65322355

TC = SHORT HEAD TL = LONG HEAD

Lined area for notes or text.

La ECOFLAM BRUCIATORI S.p.A si riserva il diritto di apportare ai prodotti quelle modifiche che riterrà necessarie o utili, senza pregiudicarne le caratteristiche principali.

ECOFLAM BRUCIATORI S.p.A. reserves the right to make any adjustments, without prior notice, which it considers necessary or useful to its products, without affecting their main features.

La Maison ECOFLAM BRUCIATORI S.p.A. se réserve le droit d'apporter les modifications qu'elle jugera nécessaires ou utiles à ses produits sans pour autant nuire à leurs caractéristiques principales.

ECOFLAM BRUCIATORI S.p.A. se reserva el derecho a introducir en sus productos todas las modificaciones que considere necesarias o utiles, sin perjudicar sus características.

“Экофлам С.п.А.” оставляет за собой право вносить в конструкцию оборудования любые необходимые изменения без особого предупреждения.

Ecoflam

Ecoflam Bruciatori S.p.A.

via Roma, 64 - 31023 RESANA (TV) - Italy - tel. 0423.719500 - fax 0423.719580

<http://www.ecoflam-burners.com> - e-mail: export@ecoflam-burners.com

"società soggetta alla direzione e al coordinamento della Ariston Thermo S.p.A., via A. Merloni, 45 - 60044 Fabriano (An) CF 01026940427"