



Product is subject to and complies with Regulation (UE) N.327/2011

Fan Coil Unit Cassette SkyStar Jumbo ECM

TECHNICAL CATALOGUE

SkyStar Jumbo ECM





TABLE OF CONTENTS

Introduction	p. 4
Main components	p. 5
Technical features	p. 7
Cooling emission	p. 8
Heating emission	p. 11
Water side pressure drops	p. 12
Operating limits	p. 13
Dimensions and weights	p. 14
Air throw	p. 15
Accessories	p. 16
SK-ECM configuration	p. 18
Controls for SK-ECM units	p. 18
SK-ECM-MB configuration	p. 19
Controls for SK-ECM-MB units	p. 20
SK-ECM-E / SK-ECM-MB-E configuration	p. 21

INTRODUCTION

Innovating and beautiful design, perfect to meet all air-conditioning requirements of wide environments, 2 different models, high control flexibility, easy maintenance: the new cassette fan coil unit **SkyStar Jumbo ECM** is the result of an extended technical and design development aimed at achieving the highest level in terms of performance, silent operation and control possibility.

The air diffuser has an highly attractive aesthetical appearance, very innovative, and is also able to offer the best air distribution performance thanks to long computer studies and laboratory tests. The standard colour is RAL 9003, other colours available on request.

The bigger sizes allow the best outcome in terms of quietness and of price/performance ratio for these high capacity models.

Every unit can be supplied with 1 coil (2 pipe system) and a possible electric heater or with 2 coils (4 pipe system). Each model can have fresh air intake and a remote air diffuser can be connected to the unit.

The float switch centrifugal pump is particularly silent, with 650 mm of maximum head.

In addition to temperature and speed standard controls, automatic speed selection is also available. More than one unit can be connected to a single control.

All the units **SkyStar Jumbo ECM** can be supplied in the version **SK-ECM-MB**. This version allows a wide range of controls, including the infra-red remote control, which can manage one single unit or several units by using the Bus communication protocol. The units can be connected to the most common automatic building management systems.

In the MB version it is possible to control at the same time the (motorized) outlet louvers with the remote-control or with the T-MB wall control.

The outlet louvers position themselves automatically according to the selected operation (summer-winter) and can be managed with the swing mode, that guarantees a complete air distribution in the environment.

The range **SkyStar Jumbo ECM** uses an innovative brushless synchronous permanent magnet electric motor controlled by an inverter board that is directly installed on the unit.

The air flow can be varied continuously with a 1-10 V signal from **Sabiana** controls or by independent controllers (programmable controllers with a 1-10V output). The extreme efficiency, also at a low speed, makes possible a great reduction in electric consumption (more than 75% less in comparison to a traditional motor) with absorption values, under normal operating conditions, that are no greater than 20 Watt in the entire range.

The brushless motor is characterised by a constant synchronous speed, independently of the applied load, that depends only on the motor power supply frequency, which is modulated by the inverter.

it consumes less because:

- The motor always works at its point of maximum efficiency.
- In the brushless motor, the rotor's permanent magnets generate the magnetising power autonomously.
- the motor always operates at the synchronous speed, as a result there are no induced currents that reduce efficiency.

The main advantages are:

- Large reduction in energy consumption, thanks to an optimal response to the thermal load of the environment during every moment of the day.
- Operating silence at all rotation speeds.
- Ability to operate at any rotation speed.

MAIN COMPONENTS

Air diffuser

Intake grids, frame and adjustable air distribution louvers on each side, made of ABS. In the **SK-ECM-MB** version the outlet louvers are adjustable with remote control or with T-MB wall control (for the **SK-ECM** version manually only); the return and supply air grids are available with both the G0 filter and with the F7 filter.

- HTA version: white ABS, RAL 9003
- HTB version: in one single color to choose

HTA version



HTB version



Casing

It is made of galvanized steel with internal thermal insulation with polyolefin (PO) foam (class M1) and external anti-condensate lining.

Control Panel

- **SK-ECM** version

It consists of the pump control circuit board and the inverter circuit board.

• **SK-ECM-MB** version

It consists of the MB electronic board (that integrates pump control) and the inverter board.

The diffusion louvers are adjustable with remote control or with T-MB wall control.

Fan assembly

The fan assembly, secured on anti-vibration mountings, is particularly silent.

The radial fan has been designed to optimise performance, using wing profile blades with a shape that reduces turbulence, increasing efficiency and reducing noise.

The fans are connected to a three phase permanent magnet brushless electronic motor that is controlled with reconstructed current according to a BLAC sinusoidal wave.

The inverter board that controls the motor operation is powered by 230 Volt, single-phase and, with a switching system, it generates a three-phase frequency modulated, wave form power supply.

The electric power supply required for the machine is therefore single-phase with voltage of 230 - 240 V and frequency of 50 - 60 Hz.

Coil

Made of copper tubes with bonded aluminium fins for maximum transfer contact.

3 row coil for 2 pipe models and 2,5 + 1/2 row coil for 4 pipe models (the heating row is on the inside part of the coil).

The heat exchanger is not suitable for use in corrosive atmosphere or in environments where aluminium may be subject to corrosion.

Condensate collection tray

High density polystyrene foam condensate tray, shaped in order to optimize the air diffusion.

Fire retardant rating B1 to DIN 4102.

Filter

Easy access to the filter that is available in both versions, in the G0 and in the F7 one.

Condensate pump

Float switch centrifugal pump with 650 mm of maximum head, integral to the unit and wired to the control panel on the outside of the casing.

Valve set

Two or three way valves for ON/OFF operation, with pipe mounting kit and ball valves

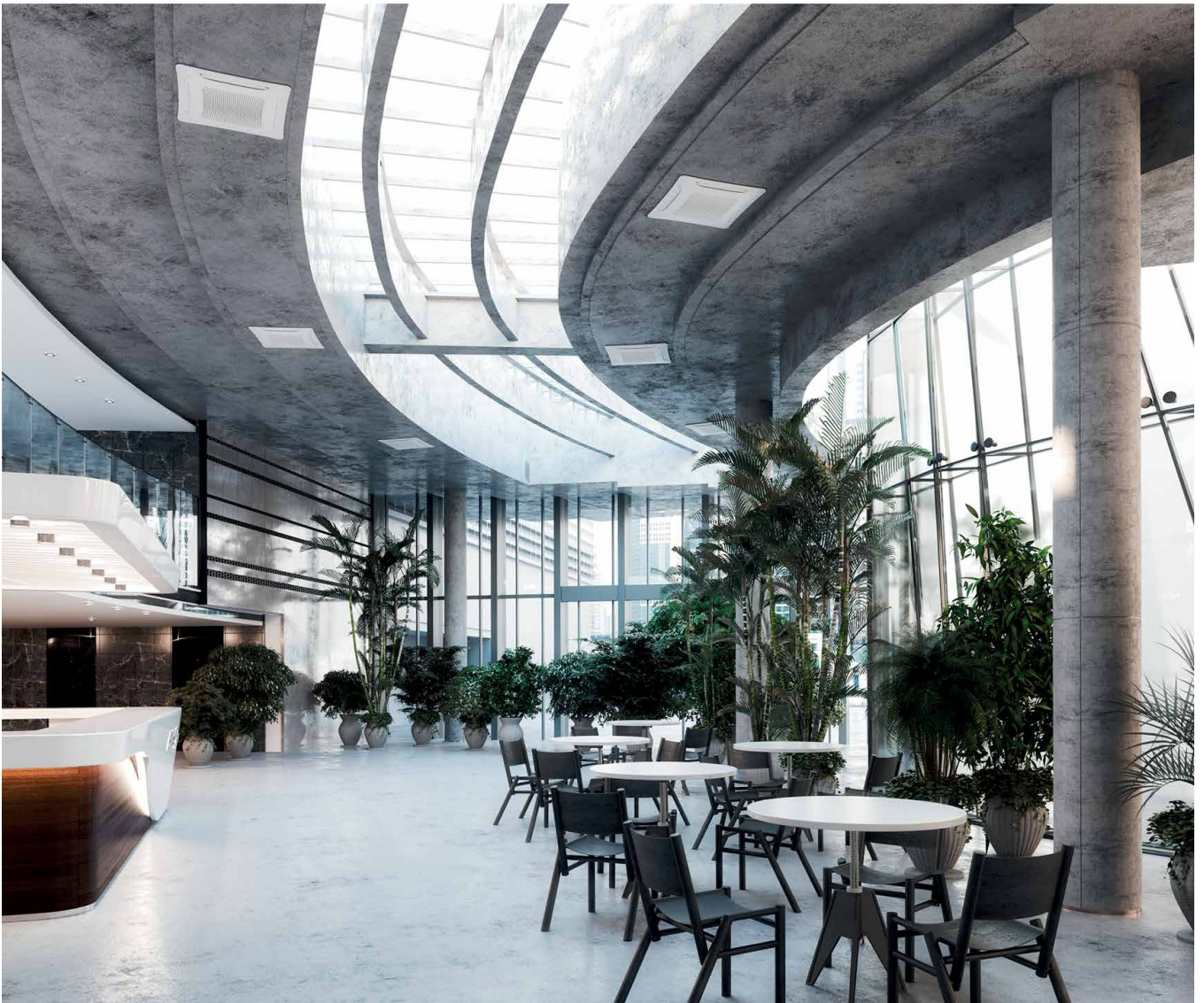

Technical features for 2 pipe unit

The following standard rating conditions are used:

COOLING

Entering air temperature: + 27°C d.b. + 19°C w.b.
Water temperature: +7°C E.W.T. +12°C L.W.T.

HEATING

Entering air temperature: + 20°C
Water temperature: +45°C E.W.T. +40°C L.W.T.

MODEL	Speed	SK-ECM 72					SK-ECM 82				
		1	3	5	7,5	10	1	3	5	7,5	10
		MIN		MED		MAX	MIN		MED		MAX
Air flow	m ³ /h	790	1040	1290	1600	1905	1025	1340	1650	2060	2480
Cooling total emission	kW	6,36	7,95	9,43	11,10	12,60	7,86	9,72	11,38	13,35	15,13
Cooling sensible emission	kW	4,45	5,65	6,77	8,09	9,31	5,58	7,00	8,30	9,88	11,41
Heating	kW	6,18	7,93	9,59	11,55	13,39	7,82	9,91	11,86	14,29	16,40
DP Cooling	kPa	6,6	9,8	13,4	18,0	22,7	9,6	14,1	18,8	25,2	31,8
DP Heating	kPa	5,4	8,4	11,8	16,5	21,5	8,2	12,5	17,3	24,2	31,0
Fan	W	13	22	35	59	93	21	38	64	113	183
Sound power Lw	dB(A)	38	44	49	54	58	44	50	55	60	64
Sound pressure ⁽¹⁾	dB(A)	29	35	40	45	49	35	41	46	51	55
Water content	l	4,6					4,6				
Dimensions	mm	816 x 816 x 303									

Condensate pump absorption: 10 W

⁽¹⁾ The sound pressure levels are 9 dB(A) lower than the sound power levels and apply to the reverberant field of a 100 m³ room and a reverberation time of 0.5 sec.

Technical features for 4 pipe unit

The following standard rating conditions are used:

COOLING

Entering air temperature: + 27°C d.b. + 19°C w.b.
Water temperature: +7°C E.W.T. +12°C L.W.T.

HEATING

Entering air temperature: + 20°C
Water temperature: +65 °C E.W.T. +55 °C L.W.T.

MODEL	Speed	SK-ECM 76					SK-ECM 86				
		1	3	5	7,5	10	1	3	5	7,5	10
		MIN		MED		MAX	MIN		MED		MAX
Air flow	m ³ /h	790	1040	1290	1600	1905	1025	1340	1650	2060	2440
Cooling total emission	kW	6,07	7,53	8,86	10,35	11,61	7,45	9,10	10,59	12,30	13,59
Cooling sensible emission	kW	4,33	5,46	6,53	7,74	8,87	5,40	6,73	7,96	9,44	10,68
Heating	kW	6,01	7,27	8,40	9,63	10,55	7,19	8,62	9,80	11,05	12,17
DP Cooling	kPa	7,0	10,3	13,8	18,3	22,6	10,1	14,5	19,1	25,2	30,4
DP Heating	kPa	7,2	10,2	13,2	16,9	19,9	10,0	13,8	17,4	21,6	25,7
Fan	W	13	22	35	59	93	21	38	64	113	183
Sound power Lw	dB(A)	38	44	49	54	58	44	50	55	60	64
Sound pressure ⁽¹⁾	dB(A)	29	35	40	45	49	35	41	46	51	55
Cooling water content	l	3,6					3,6				
Heating water content	l	1,2					1,2				
Dimensions	mm	816 x 816 x 303									

Condensate pump absorption: 10 W

⁽¹⁾ The sound pressure levels are 9 dB(A) lower than the sound power levels and apply to the reverberant field of a 100 m³ room and a reverberation time of 0.5 sec.

COOLING EMISSION

Entering air temperature: 27°C – R.H.: 50%

Model	Speed	Vdc	Qv m³/h	WT: 7 / 12 °C				WT: 8 / 13 °C				WT: 10 / 15 °C				WT: 12 / 17 °C			
				Pc kW	Ps kW	Qw l/h	Dp(c) kPa	Pc kW	Ps kW	Qw l/h	Dp(c) kPa	Pc kW	Ps kW	Qw l/h	Dp(c) kPa	Pc kW	Ps kW	Qw l/h	Dp(c) kPa
SK-ECM 72	MAX	10	1905	13,52	9,25	2341	25,7	12,21	8,73	2116	21,3	9,70	7,68	1684	14,0	6,96	6,96	1213	7,7
		7,5	1600	11,90	8,07	2058	20,4	10,77	7,59	1862	16,9	8,58	6,69	1486	11,2	6,63	5,86	1150	7,0
	MED	5	1290	10,11	6,77	1744	15,1	9,14	6,36	1577	12,6	7,31	5,60	1264	8,3	5,65	4,90	978	5,2
		3	1040	8,52	5,65	1470	11,1	7,74	5,32	1335	9,3	6,19	4,66	1068	6,2	4,77	4,08	825	3,8
	MIN	1	790	6,80	4,45	1172	7,4	6,19	4,19	1067	6,2	4,99	3,68	860	4,2	3,85	3,22	665	2,6
SK-ECM 82	MAX	10	2440	16,21	11,31	2819	35,9	14,60	10,67	2543	29,7	11,59	9,41	2025	19,5	8,49	8,49	1491	11,1
		7,5	2060	14,28	9,84	2476	28,5	12,92	9,28	2242	23,6	10,23	8,17	1779	15,4	7,39	7,39	1291	8,6
	MED	5	1650	12,18	8,27	2106	21,3	11,03	7,79	1907	17,7	8,74	6,85	1515	11,5	6,78	6,01	1177	7,2
		3	1340	10,41	6,98	1797	16,0	9,43	6,57	1628	13,3	7,51	5,77	1299	8,8	5,81	5,06	1005	5,5
	MIN	1	1025	8,42	5,58	1453	10,9	7,64	5,25	1318	9,1	6,13	4,61	1057	6,0	4,73	4,03	816	3,8
SK-ECM 76	MAX	10	1905	12,40	8,78	2149	25,5	11,20	8,31	1942	21,1	8,93	7,36	1553	13,9	6,65	6,65	1160	8,2
		7,5	1600	11,03	7,69	1908	20,6	10,01	7,28	1731	17,2	7,97	6,43	1381	11,3	5,83	5,83	1013	6,4
	MED	5	1290	9,47	6,49	1635	15,6	8,57	6,11	1480	12,9	6,84	5,40	1183	8,6	5,32	4,75	921	5,4
		3	1040	8,07	5,44	1391	11,6	7,30	5,13	1259	9,7	5,82	4,51	1005	6,4	4,53	3,97	782	4,0
	MIN	1	790	6,50	4,32	1121	7,9	5,88	4,06	1014	6,6	4,73	3,57	816	4,4	3,67	3,14	634	2,8
SK-ECM 86	MAX	10	2440	14,48	10,52	2522	34,0	13,08	9,98	2281	28,2	10,41	8,85	1822	18,6	7,94	7,94	1396	11,4
		7,5	2060	13,05	9,31	2264	28,0	11,81	8,82	2051	23,3	9,40	7,81	1635	15,3	7,04	7,04	1231	9,1
	MED	5	1650	11,27	7,87	1949	21,4	10,22	7,45	1768	17,8	8,13	6,58	1409	11,7	5,97	5,97	1038	6,7
		3	1340	9,74	6,69	1681	16,4	8,82	6,30	1524	13,6	7,04	5,57	1217	9,0	5,47	4,90	947	5,7
	MIN	1	1025	7,98	5,38	1376	11,4	7,22	5,07	1246	9,5	5,79	4,47	1000	6,3	4,48	3,92	774	3,9

- WT:** Water temperature
- Pc:** Total emission
- Ps:** Sensible emission
- Qw:** Water flow rate
- Dp(c):** Water pressure drop
- Vdc:** Inverter power
- MAX:** High speed
- MED:** Medium speed
- MIN:** Low speed
- Qv:** Air flow rate

Correction factors for different R.H.

R.H.		Water temperature (WT)				
		8 / 13	9 / 14	10 / 15	11 / 16	12 / 17
%		°C	°C	°C	°C	°C
48	Pc	0,94	0,93	1,00	1,00	1,00
	Ps	1,00	1,00	1,00	1,00	1,00
46	Pc	0,88	0,92	1,00	1,00	1,00
	Ps	1,00	1,00	1,00	1,00	1,00

R.H.: Relative Humidity

Entering air temperature 26°C – R.H.: 50%

Model	Speed	Vdc	Qv m ³ /h	WT: 7 / 12 °C				WT: 8 / 13 °C				WT: 10 / 15 °C				WT: 12 / 17 °C			
				Pc kW	Ps kW	Qw l/h	Dp(c) kPa	Pc kW	Ps kW	Qw l/h	Dp(c) kPa	Pc kW	Ps kW	Qw l/h	Dp(c) kPa	Pc kW	Ps kW	Qw l/h	Dp(c) kPa
SK-ECM 72	MAX	10	1905	12,13	8,75	2102	21,2	10,85	8,19	1883	17,3	8,55	7,21	1487	11,2	6,39	6,39	1116	6,6
		7,5	1600	10,67	7,61	1846	16,8	9,56	7,13	1655	13,7	7,57	6,28	1311	8,9	5,58	5,58	971	5,1
	MED	5	1290	9,07	6,38	1565	12,5	8,16	5,98	1410	10,3	6,45	5,25	1115	6,6	4,70	4,70	814	3,7
		3	1040	7,67	5,33	1322	9,2	6,90	4,99	1190	7,6	5,46	4,38	943	4,9	4,17	3,82	721	3,0
	MIN	1	790	6,13	4,21	1056	6,1	5,53	3,94	954	5,1	4,39	3,45	757	3,3	3,36	3,01	580	2,0
SK-ECM 82	MAX	10	2440	14,49	10,67	2523	29,4	12,94	10,03	2257	23,9	10,26	8,85	1797	15,7	7,78	7,78	1370	9,5
		7,5	2060	12,78	9,30	2218	23,3	11,44	8,72	1988	19,0	9,04	7,68	1574	12,4	6,79	6,79	1187	7,4
	MED	5	1650	10,93	7,80	1891	17,5	9,78	7,31	1694	14,3	7,72	6,43	1338	9,2	5,72	5,72	995	5,4
		3	1340	9,35	6,59	1615	13,2	8,40	6,17	1451	10,8	6,63	5,42	1147	7,0	4,84	4,84	840	3,9
	MIN	1	1025	7,58	5,27	1307	9,0	6,82	4,94	1176	7,4	5,40	4,32	932	4,8	4,12	3,77	713	2,9
SK-ECM 76	MAX	10	1905	11,14	8,33	1932	21,0	9,94	7,83	1725	17,0	7,93	6,93	1380	11,3	6,10	6,10	1065	7,0
		7,50	1600	9,95	7,30	1721	17,1	8,88	6,84	1538	13,9	7,04	6,04	1221	9,0	5,35	5,35	931	5,5
	MED	5	1290	8,52	6,13	1471	12,9	7,62	5,76	1317	10,5	6,03	5,07	1043	6,8	4,53	4,53	785	4,0
		3	1040	7,25	5,15	1251	9,6	6,51	4,82	1124	7,9	5,15	4,24	889	5,1	3,80	3,80	658	2,9
	MIN	1	790	5,85	4,08	1009	6,5	5,27	3,83	909	5,4	4,18	3,36	722	3,5	3,21	2,94	555	2,2
SK-ECM 86	MAX	10	2440	13,03	10,00	2272	28,1	11,64	9,41	2033	22,9	8,61	8,61	1512	13,3	7,26	7,26	1280	9,7
		7,5	2060	11,76	8,85	2042	23,2	10,50	8,31	1825	18,9	8,33	7,35	1452	12,4	6,45	6,45	1129	7,8
	MED	5	1650	10,16	7,47	1758	17,7	9,07	7,00	1571	14,4	7,17	6,19	1244	9,4	5,48	5,48	954	5,7
		3	1340	8,77	6,34	1514	13,6	7,83	5,94	1353	11,0	6,19	5,23	1071	7,1	4,67	4,67	809	4,3
	MIN	1	1025	7,17	5,08	1237	9,4	6,45	4,76	1112	7,7	5,11	4,20	882	5,0	3,76	3,76	650	2,9

WT: Water temperature
Pc: Total emission
Ps: Sensible emission
Qw: Water flow rate
Dp(c): Water pressure drop
Vdc: Inverter power
MAX: High speed
MED: Medium speed
MIN: Low speed
Qv: Air flow rate

Correction factors for different R.H.

R.H.		Water temperature (WT)				
		8 / 13	9 / 14	10 / 15	11 / 16	12 / 17
%		°C	°C	°C	°C	°C
48	Pc	0,94	0,93	1,00	1,00	1,00
	Ps	1,00	1,00	1,00	1,00	1,00
46	Pc	0,88	0,92	1,00	1,00	1,00
	Ps	1,00	1,00	1,00	1,00	1,00

R.H.: Relative Humidity

Entering air temperature: 25°C – R.H.: 50%

Model	Speed	Vdc	WT: 7 / 12 °C					WT: 8 / 13 °C					WT: 10 / 15 °C					WT: 12 / 17 °C				
			Qv m ³ /h	Pc kW	Ps kW	Qw l/h	Dp(c) kPa	Pc kW	Ps kW	Qw l/h	Dp(c) kPa	Pc kW	Ps kW	Qw l/h	Dp(c) kPa	Pc kW	Ps kW	Qw l/h	Dp(c) kPa			
SK-ECM 72	MAX	10	1905	10,80	8,21	1874	17,2	9,64	7,70	1674	14,0	7,53	6,75	1310	8,9	5,82	5,82	1018	5,6			
		7,5	1600	9,51	7,15	1646	13,6	8,52	6,72	1476	11,1	6,63	5,87	1151	7,0	5,09	5,09	886	4,4			
	MED	5	1290	8,11	6,00	1401	10,2	7,25	5,62	1254	8,3	5,65	4,92	977	5,2	4,29	4,29	744	3,2			
		3	1040	6,86	5,01	1184	7,5	6,13	4,69	1059	6,1	4,79	4,10	827	3,9	3,59	3,59	622	2,3			
	MIN	1	790	5,50	3,96	948	5,1	4,93	3,70	851	4,1	3,85	3,23	665	2,6	2,86	2,86	495	1,5			
SK-ECM 82	MAX	10	2440	12,91	10,07	2251	24,0	11,54	9,45	2016	19,5	8,49	8,49	1492	11,2	7,07	7,07	1247	8,0			
		7,5	2060	11,41	8,73	1981	19,0	10,17	8,21	1769	15,4	7,40	7,40	1292	8,7	6,18	6,18	1082	6,2			
	MED	5	1650	9,75	7,33	1688	14,3	8,70	6,88	1508	11,6	6,78	6,02	1177	7,3	5,22	5,22	908	4,5			
		3	1340	8,35	6,19	1442	10,8	7,46	5,80	1290	8,7	5,81	5,07	1006	5,5	4,43	4,43	768	3,4			
	MIN	1	1025	6,79	4,95	1171	7,4	6,08	4,64	1050	6,0	4,73	4,05	818	3,8	3,55	3,55	615	2,3			
SK-ECM 76	MAX	10	1905	9,94	7,84	1726	17,2	8,89	7,38	1545	14,0	6,65	6,65	1160	8,3	5,54	5,54	969	5,9			
		7,5	1600	8,82	6,86	1528	13,8	7,91	6,44	1370	11,3	5,84	5,84	1014	6,5	4,87	4,87	848	4,6			
	MED	5	1290	7,59	5,77	1311	10,5	6,81	5,42	1177	8,6	5,32	4,76	921	5,4	4,13	4,13	716	3,4			
		3	1040	6,49	4,84	1119	7,9	5,78	4,54	999	6,4	4,53	3,98	782	4,1	3,47	3,47	601	2,5			
	MIN	1	790	5,24	3,84	903	5,3	4,69	3,59	809	4,4	3,68	3,15	635	2,8	2,78	2,78	481	1,7			
SK-ECM 86	MAX	10	2440	11,61	9,42	2028	22,9	10,38	8,87	1816	18,7	7,93	7,93	1396	11,5	6,58	6,58	1163	8,2			
		7,5	2060	10,47	8,31	1821	18,9	9,36	7,83	1629	15,4	7,05	7,05	1231	9,2	5,86	5,86	1027	6,6			
	MED	5	1650	9,03	7,01	1564	14,4	8,07	6,59	1399	11,7	5,97	5,97	1039	6,8	4,99	4,99	869	4,8			
		3	1340	7,79	5,95	1347	11,0	6,99	5,59	1209	9,0	5,48	4,91	948	5,7	4,25	4,25	738	3,6			
	MIN	1	1025	6,41	4,78	1106	7,7	5,72	4,48	988	6,2	4,48	3,93	774	4,0	3,43	3,43	594	2,4			

- WT:** Water temperature
- Pc:** Total emission
- Ps:** Sensible emission
- Qw:** Water flow rate
- Dp(c):** Water pressure drop
- Vdc:** Inverter power
- MAX:** High speed
- MED:** Medium speed
- MIN:** Low speed
- Qv:** Air flow rate

Correction factors for different R.H.

R.H.		Water temperature (WT)				
		8 / 13	9 / 14	10 / 15	11 / 16	12 / 17
%		°C	°C	°C	°C	°C
48	Pc	0,94	0,93	1,00	1,00	1,00
	Ps	1,00	1,00	1,00	1,00	1,00
46	Pc	0,88	0,92	1,00	1,00	1,00
	Ps	1,00	1,00	1,00	1,00	1,00

R.H.: Relative Humidity

HEATING EMISSION

Entering air temperature: 20°C

Model	Speed	Vdc	Qv m ³ /h	WT: 65 / 55 °C			WT: 60 / 50 °C			WT: 50 / 40 °C			WT: 50 / 45 °C			WT: 45 / 40 °C		
				Ph kW	Qw l/h	Dp(c) kPa	Ph kW	Qw l/h	Dp(c) kPa	Ph kW	Qw l/h	Dp(c) kPa	Ph kW	Qw l/h	Dp(c) kPa	Ph kW	Qw l/h	Dp(c) kPa
SK-ECM 72	MAX	10	1905	24,08	2070	17,00	21,08	1813	13,50	15,06	1295	7,60	16,34	1405	30,40	13,39	1151	21,50
		7,5	1600	20,78	1787	13,00	18,21	1566	10,40	13,05	1122	5,90	14,08	1211	23,20	11,55	993	16,50
	MED	5	1290	17,25	1483	9,30	15,14	1302	7,50	10,90	937	4,20	11,67	1003	16,60	9,59	825	11,80
		3	1040	14,26	1226	6,60	12,54	1078	5,30	9,06	779	3,00	9,63	828	11,70	7,93	682	8,40
	MIN	1	790	11,12	956	4,20	9,79	842	3,40	7,11	611	2,00	7,49	644	7,50	6,18	531	5,40
SK-ECM 82	MAX	10	2440	29,49	2536	24,40	25,79	2218	19,40	18,33	1577	10,80	20,06	1725	43,90	16,40	1411	31,00
		7,5	2060	25,69	2210	19,10	22,49	1934	15,20	16,04	1379	8,50	17,45	1500	34,20	14,29	1229	24,20
	MED	5	1650	21,33	1834	13,60	18,69	1608	10,90	13,39	1151	6,10	14,45	1243	24,40	11,86	1020	17,30
		3	1340	17,83	1533	9,90	15,65	1346	7,90	11,25	968	4,50	12,06	1038	17,60	9,91	852	12,50
	MIN	1	1025	14,08	1211	6,50	12,38	1064	5,20	8,94	769	3,00	9,50	817	11,50	7,82	673	8,20

WT: Water temperature
Ph: Total emission
Qw: Water flow rate
Dp(c): Water pressure drop
Vdc: Inverter power
MAX: High speed
MED: Medium speed
MIN: Low speed
Qv: Air flow rate

Entering air temperature: 20°C

Model	Speed	Vdc	Qv m ³ /h	WT: 70 / 60 °C			WT: 60 / 50 °C			WT: 50 / 40 °C			WT: 50 / 45 °C			WT: 45 / 40 °C		
				Ph kW	Qw l/h	Dp(c) kPa	Ph kW	Qw l/h	Dp(c) kPa	Ph kW	Qw l/h	Dp(c) kPa	Ph kW	Qw l/h	Dp(c) kPa	Ph kW	Qw l/h	Dp(c) kPa
SK-ECM 76	MAX	10	1905	12,04	1036	24,90	9,07	780	15,30	6,10	525	7,70	7,36	633	37,40	5,89	507	25,50
		7,5	1600	10,98	944	21,10	8,28	712	13,00	5,58	480	6,60	6,71	577	31,70	5,38	463	21,60
	MED	5	1290	9,58	824	16,50	7,23	621	10,20	4,88	420	5,20	5,85	503	24,80	4,69	404	16,90
		3	1040	8,28	712	12,70	6,25	538	7,90	4,23	364	4,00	5,06	435	19,10	4,06	349	13,00
	MIN	1	790	6,84	588	9,00	5,17	445	5,60	3,51	301	2,90	4,18	359	13,50	3,35	289	9,20
SK-ECM 86	MAX	10	2440	13,89	1195	32,30	10,45	899	19,80	7,02	604	10	8,50	731	48,50	6,80	585	32,90
		7,5	2060	12,61	1085	27,10	9,49	817	16,70	6,39	549	8,40	7,71	663	40,70	6,17	531	27,70
	MED	5	1650	11,18	961	21,80	8,42	724	13,40	5,68	488	6,80	6,83	588	32,80	5,48	471	22,30
		3	1340	9,83	845	17,30	7,41	637	10,70	5,00	430	5,40	6,00	516	25,90	4,81	414	17,70
	MIN	1	1025	8,20	705	12,50	6,19	532	7,70	4,19	360	3,90	5,01	431	18,70	4,02	346	12,80

WT: Water temperature
Ph: Total emission
Qw: Water flow rate
Dp(c): Water pressure drop
Vdc: Inverter power
MAX: High speed
MED: Medium speed
MIN: Low speed
Qv: Air flow rate

WATER SIDE PRESSURE DROPS

2 pipe system

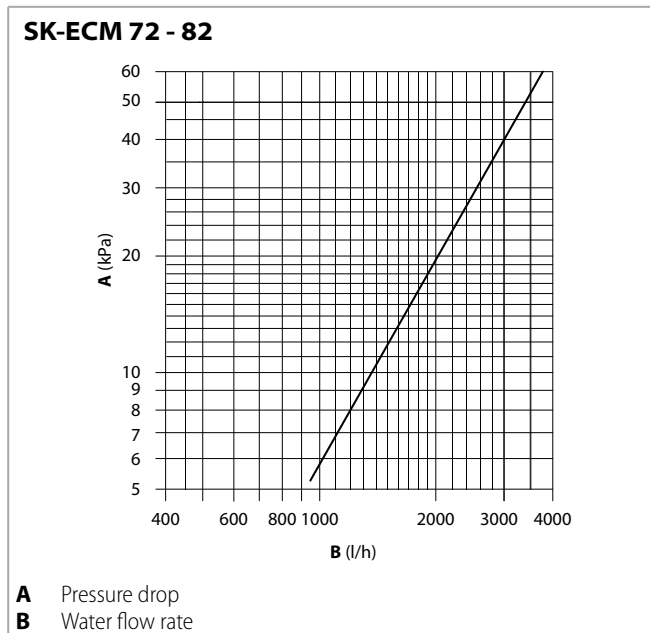

Pressure drop for mean water temperature of 10°C, for different temperatures multiply the pressure drop figure by the K correction factors in the table.

	Mean water temperature (°C)						
	20	30	40	50	60	70	80
K correction factor	0,94	0,90	0,86	0,82	0,78	0,74	0,70

4 pipe system

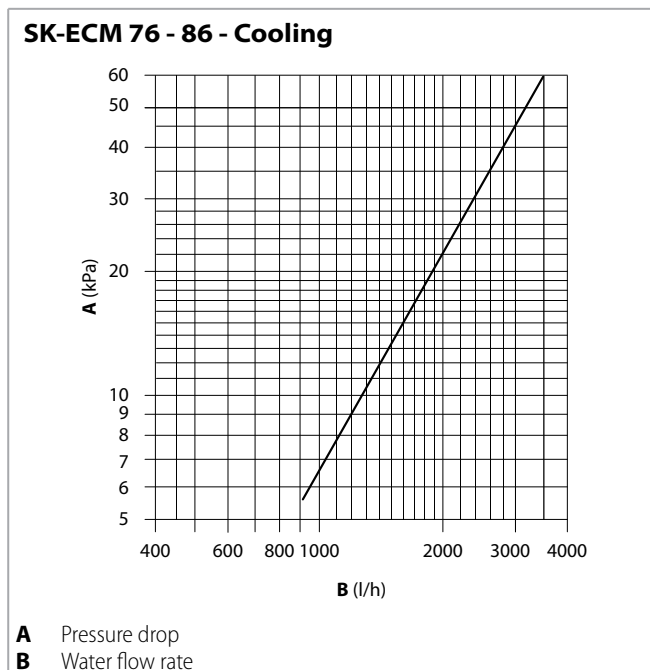

Pressure drop for mean water temperature of 10°C, for different temperatures multiply the pressure drop figure by the K correction factors in the table.

	Mean water temperature (°C)						
	20	30	40	50	60	70	80
K correction factor	0,94	0,90	0,86	0,82	0,78	0,74	0,70

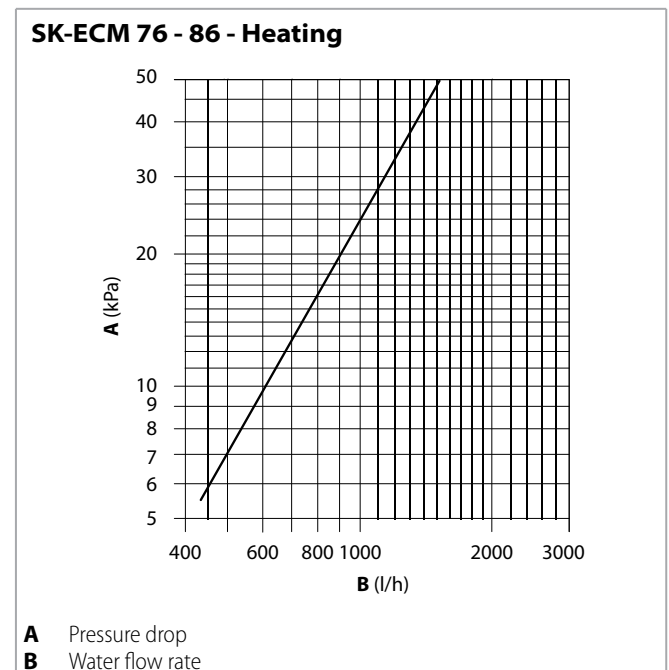

Pressure drop for mean water temperature of 60°C, for different temperatures multiply the pressure drop figure by the K correction factors in the table.

	Mean water temperature (°C)			
	40	50	70	80
K correction factor	1,12	1,06	0,94	0,88



OPERATING LIMITS

Description		UoM	Value
Water flow	Max. water pressure drop	bar	10
	MIN. entering water temperature	°C	+5
	MAX. entering water temperature mod. 72 - 82	°C	+65
	MAX. entering water temperature mod. 76 - 86	°C	+80
Ambient air	Suitable relative humidity	%	15÷75
	Minimum temperature	°C	+6
	Maximum temperature	°C	+40
Power supply	Single-phase rated operating voltage	V/Hz	230/50
Installation	Maximum height	m	See p. 15

DIMENSIONS AND WEIGHTS

SK 72-76 / SK 82-86

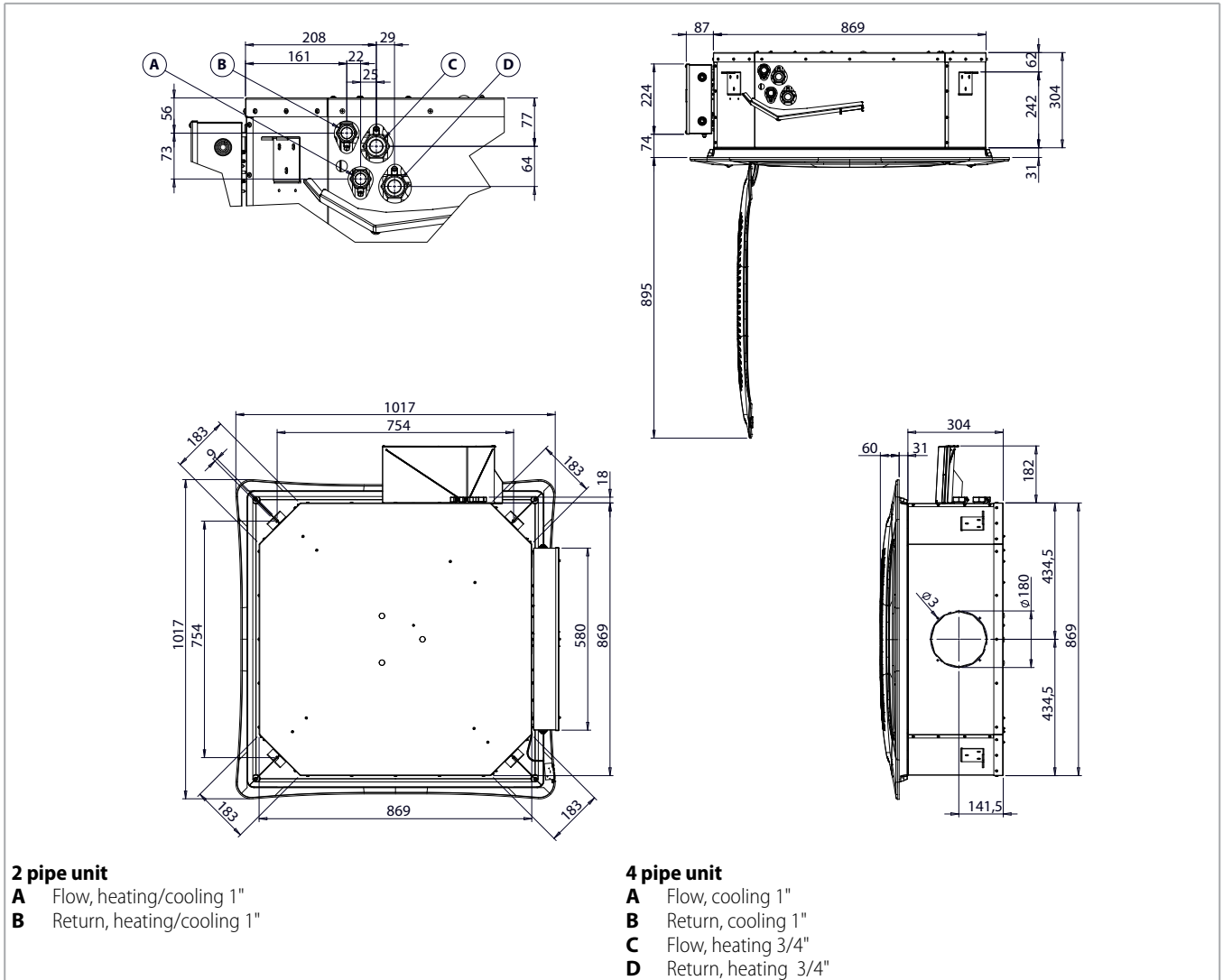

Packed unit

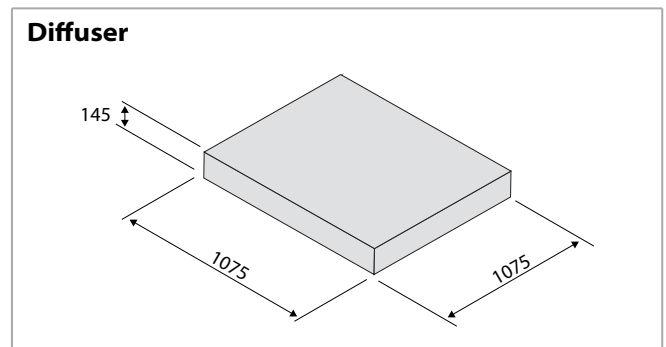
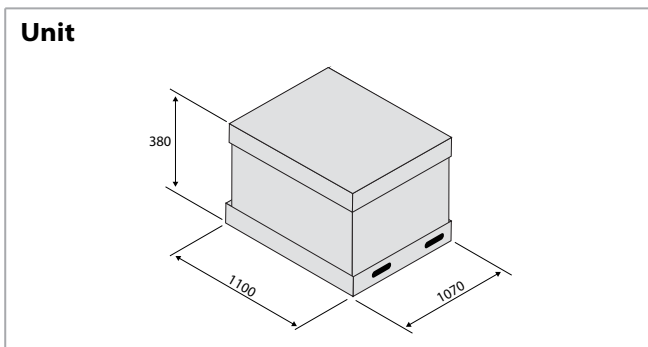

Model	SK-ECM 72	SK-ECM 76	SK-ECM 82	SK-ECM 86
Weight with packaging	kg	52		
Weight without packaging	kg	42		

Model	SK-ECM 72	SK-ECM 76	SK-ECM 82	SK-ECM 86
Weight with packaging	kg	9,4		
Weight without packaging	kg	7,5		

AIR THROW

The air throw indicated in the tables must only be considered the maximum value, as it may change significantly in relation to the dimensions of the room in which the appliance is installed and the positioning of the furniture in the room.

The useful throw L refers to the distance between the unit and the point where the air speed is 0.2 m/sec; if the

louver has a gradient of 40° (recommended in cooling mode), the so-called “Coanda” effect will occur, illustrated in the first figure, while at a gradient of 60° (recommended in heating mode), there will be a downwards throw, as illustrated in the second figure.

With adjustable air diffusion louvers at 40°

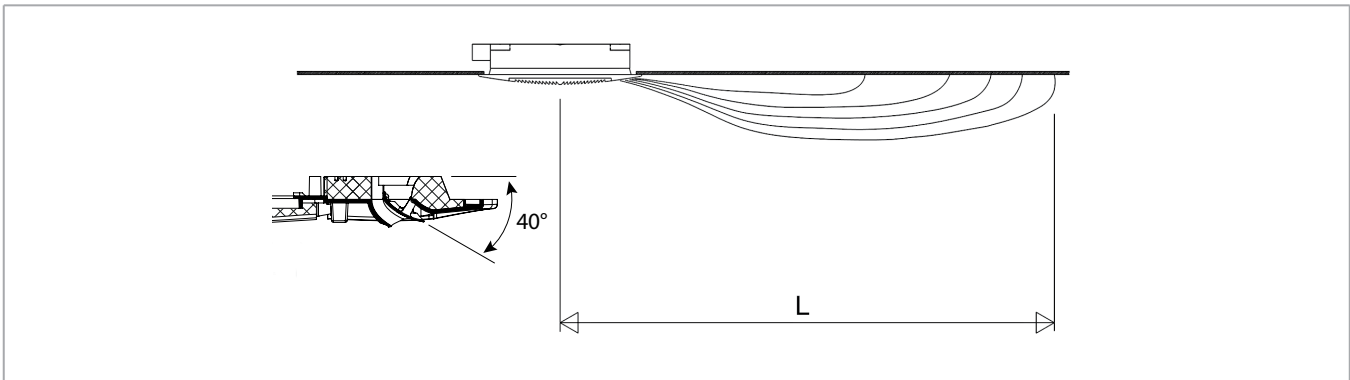

Model		SK-ECM 72-76			SK-ECM 82-86		
Speed		MIN	MED	MAX	MIN	MED	MAX
L	m	3,5	5,0	6,5	4,0	6,0	7,5

With adjustable air diffusion louvers at 60°

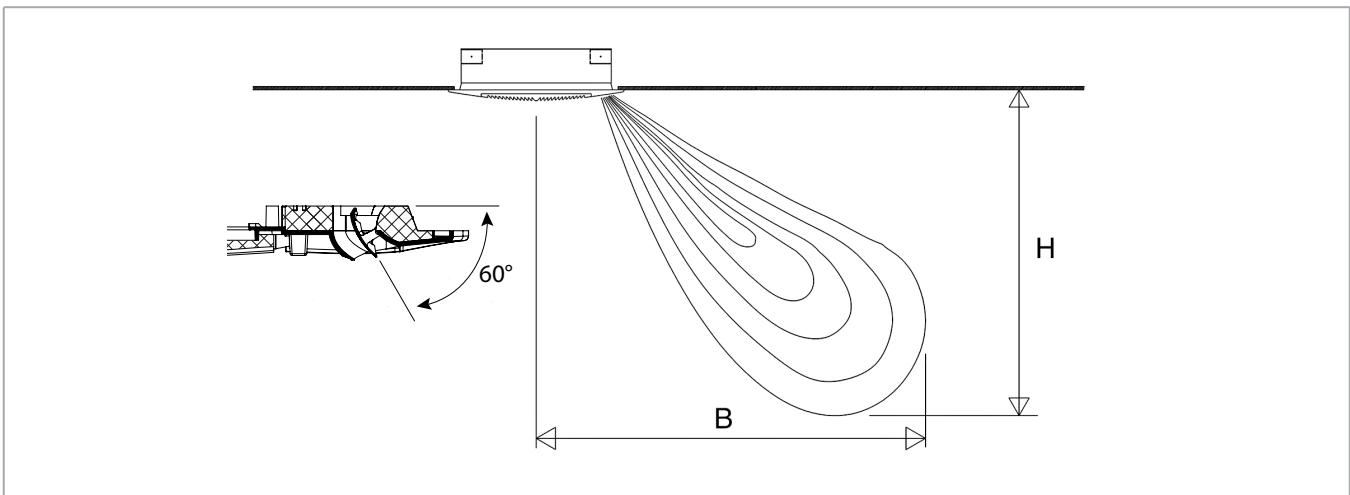

Model		SK-ECM 72-76			SK-ECM 82-86		
Speed		MIN	MED	MAX	MIN	MED	MAX
H	m	2,8	3,2	3,6	3,0	3,5	4,2
B	m	3,5	4,5	5,5	4,0	5,0	6,5

Note: on heating it must be payed attention to rooms where the floor temperature is particularly low (for example less than 5°C). In this situation the floor can cool the lower layer of air to a level that stops the uniform diffusion of the hot air coming from the unit, decreasing the throw figures shown in the table.

ACCESSORIES

Air distribution connection

Model	Code
CDA 800	9079233

Two air outlets are provided on the side of the unit for connection to separate supply air outlets. The total air flow does not change.

The air flow at high speed depending on the air duct pressure drop is shown in the tables below.

Note: all air ducts must be insulated in order to avoid condensation.

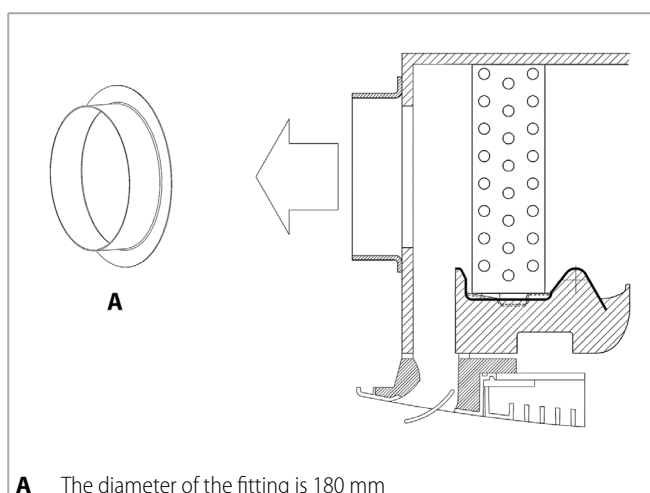
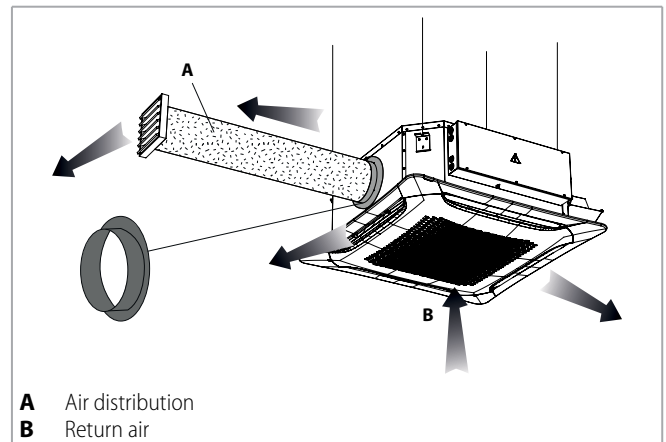
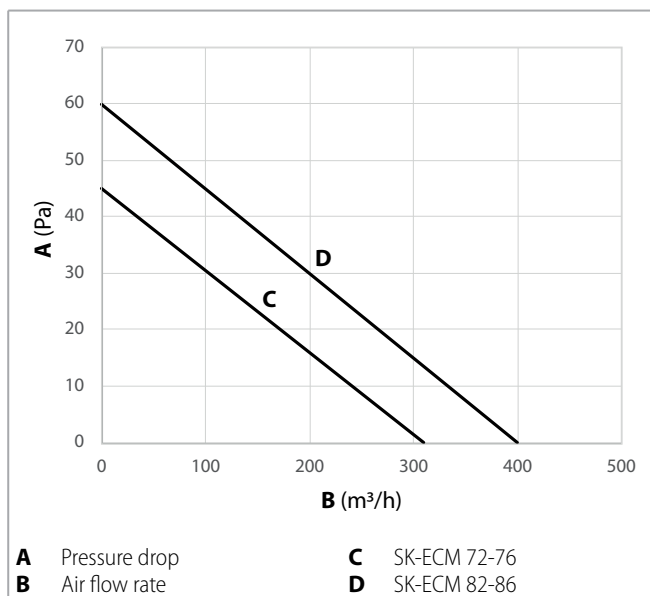

ON-OFF valves with thermoelectric actuator

Valves for ON/OFF operation, with ball valves.

3 way valve

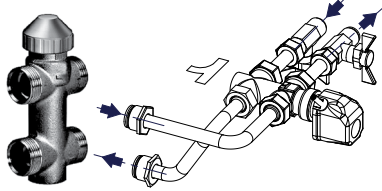

2 way valve

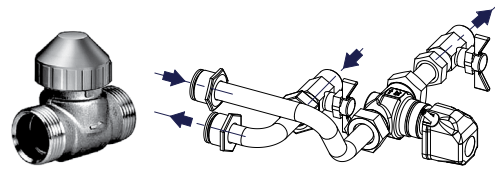

Valve with simplified kit

3 way valve

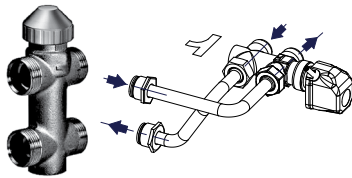

2 way valve

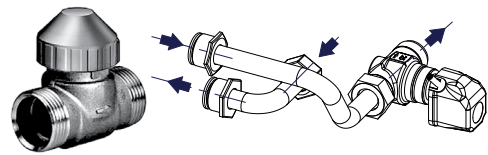

Technical features

Model	2 way valves			3 way valves			Ball valve
	Kvs	Dp max	valve	Kvs	Dp max	valve	Ø
SK-ECM 72/82/76/86 ⁽¹⁾	5,2	60	1"	4,5	50	1"	1"
SK-ECM 72/82/76/86 ⁽²⁾	2,8	50	3/4"	2,5	50	3/4"	3/4"

- ⁽¹⁾ Main coil
- ⁽²⁾ Additional coil

Technical data

Description	UoM	Value
Max. working pressure	bar	16
Max. ambient temperature	°C	50
Max. water temperature	°C	110
Power supply	V-Hz	230-50/60
Rating	VA	3
Protection		IP 43
Travel time	min	ca. 3
Max. glycol content of water:	%	50

Valve set, 2 or 3 ways, ON-OFF, with thermoelectric actuator.

The set includes connection pipes.

Water pressure drops

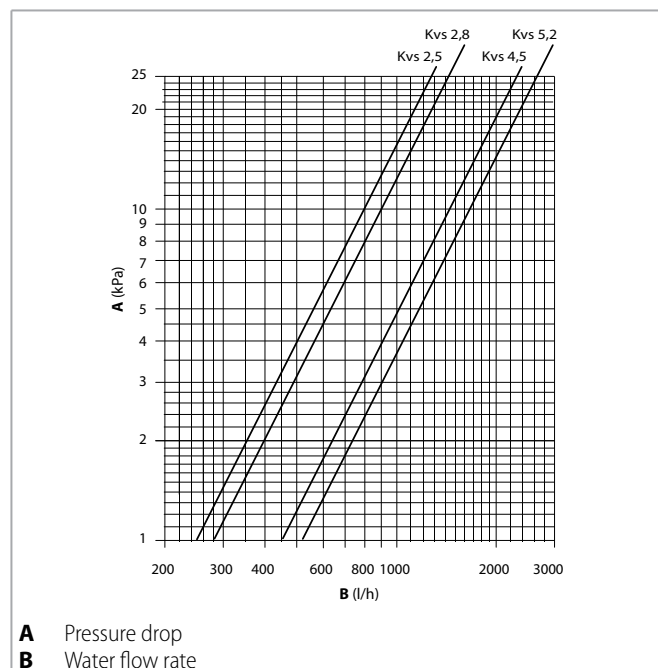

SK-ECM CONFIGURATION

For this cassette configuration, the 1-10 Vdc signal, which controls the inverter, must be supplied by a controller with the following signal specifications:

Fan drive signal

- Fan OFF = 0 Vdc
- Fan ON > 1 Vdc

- Max. speed = 10 Vdc

Blac-ECM Inverter board

- 0÷10 Vdc Circuit Input Impedance Value= 68kOhm

Power supply

- 230Vac 1Ph 50Hz

CONTROLS FOR SK-ECM UNITS

All the units of the **SkyStar Jumbo ECM** range can be supplied with a wide range of controls that allows managing one single unit or several units (with the use of the power units).

The room temperature can be controlled through electronic room thermostats, with different solutions according to every ambient conditions.

The electronic thermostats WM-AU, T-MB and WM-S-ECM rule the room temperature precisely and are suitable when the user wants to set the fan speed.

Note: all the controls are described in detail in the "Fan Coil Control Range literature".

WM-AU control



T-MB control



WM-S-ECM control



SK-ECM-MB CONFIGURATION

The MB electronic board, to be mounted on the SK-ECM-MB and SK-ECM-MB-E versions, is set to carry out different functions and adjustment modes, in order to meet the installation requirements.

The Dip Switches on the board have to be set to carry out different functions:

- 2/4 pipe unit
- Electronic room thermostat for fan control (ON-OFF)
- Electronic room thermostat for valve control (ON-OFF) (the fan keeps working)
- Simultaneous thermostatic control of the valves and fan
- Fan operation control depending on the coil temperature (cut-out T3 probe fitted), which can be activated only in heating mode or heating and cooling mode
- Automatic switch of the operating mode by means of T2 water probe (optional) applied on the 2 pipe system

- Seasonal switch by means of remote contact
- ON/OFF of the fan coil by means of the remote contact (window or clock contact)
- Electric heater control

By activating the cut-out T3 probe function, the fan is stopped in winter when the coil temperature is lower than 32 °C and started when the temperature reaches 36 °C. In summer mode, the fan stops when inside the coil exceeds 22 °C and starts when it drops below 18 °C. The following connections are located on the power board:

- Receiver for infra-red remote control
- T-MB wall control
- serial connection to manage several fan coil units in Master/Slave configuration or to create a supervisory network.

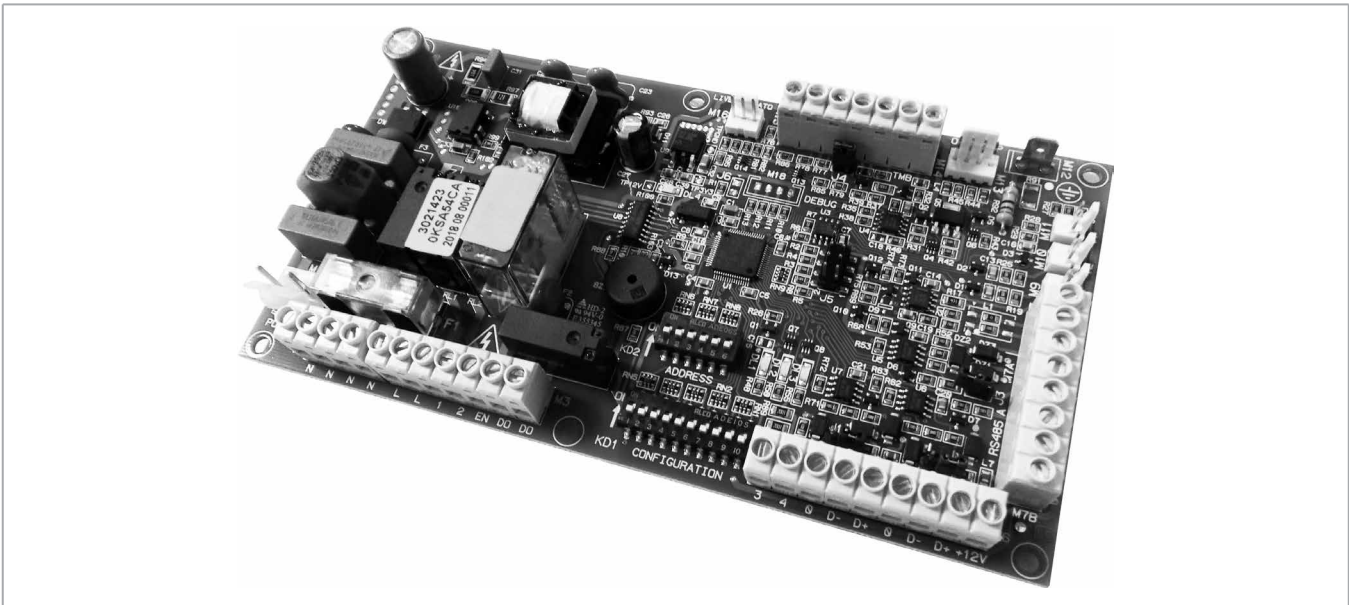

CONTROLS FOR SK-ECM-MB UNITS

All the units **SkyStar Jumbo ECM** can be supplied in MB version. This version includes a wide range of controls, including the infra-red remote control, which allows managing one single unit or several units by using the Bus communication protocol.

Units can be managed according to the Master/Slave logic (up to 20 units) or by supervisory components.

The system consists in a MB board and a series of controls, such as the T-MB wall control, the RT03 infra-red remote control, the PSM-DI multifunction control panel and the Sabianet supervisory program.

Note: all the controls are described in detail in the "Fan Coil Control Range literature".

T-MB control



PSM-DI multifunction control panel

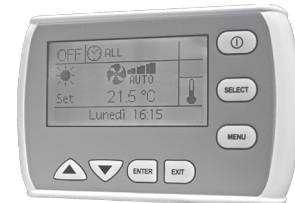

RT03 remote control



PC and Sabianet screenshot



SK-ECM-E / SK-ECM-MB-E CONFIGURATION

The 2 pipe model Cassette units are available with electric heater.

The electric heater is controlled in place of the hot water valve and not as integration to it.

The electric heaters are hermetically sealed and supplied inside the coil pipes and therefore can be only factory mounted.

The electric heaters mounted on the units are for single phase 230V or three phase 400V supply.

The Cassette fan coil unit includes no. 2 safety thermostats which intervene in case of internal over-heating, opening an auxiliary power relay (included in the electrical panel) which stops the power supply to the electric heaters.

Model		SK-ECM 72-E	SK-ECM-MB 72-E	SK-ECM 82-E	SK-ECM-MB 82-E
Emission	W	3000			
Power supply	V/Ph/Hz	230/1/50			
Connecting wires	N° x mm ²	3 x 2,5			

Note: the cooling emission of the units is 95% of the standard emission.

Cassette power supply

- 230Vac 1Ph 50Hz

Electric heater power supply

- The electric heaters can be for 230Vac 1Ph 50Hz or 400Vac 3Ph 50Hz supply.

Operation limits

Max. ambient temperature for Cassette unit with electric heater in heating mode: 25°C

The descriptions and illustrations provided in this publication are not binding: SABIANA SpA Sabiana reserves the right, whilst maintaining the essential characteristics of the types described and illustrated, to make, at any time, without the requirement to promptly update this piece of literature, any changes that it considers useful for the purpose of improvement or for any other manufacturing or commercial requirements.



A company of Arbonia Group

ARBONIA ▲



SABIANA SpA

via Piave 53 - 20011 Corbetta (MI) Italy
+39 02 97203 r.a. - +39 02 9777282
info@sabiana.it
www.sabiana.it