

NEW



WALL-HUNG CONDENSING BOILERS
with stainless steel heat exchanger

CIAOX

A Carrier Company





**NEW DIGITAL
TOUCHPAD
INTERFACE**



**HIGH
EFFICIENCY**



**QUICK AND
STABLE
HOT WATER**



**STAINLESS STEEL
HEAT EXCHANGER**



**COMPACT
DESIGN**



**LOW NOISE
OPERATION**

CIAO X, THE COMFORT YOU DESERVE.

CIAO, ONE OF THE BEST-SELLING WALL-HUNG BOILERS IN THE BERETTA PORTFOLIO EVER, HAS NOW BEEN COMPLETELY REDESIGNED, RESULTING IN A NEW CONDENSING RANGE WITH MANY INNOVATIVE FEATURES AND ADVANTAGES: CIAO X

The new Beretta range retains the distinguishing features of its predecessor in terms of **reliability and user-friendliness**, while adding many important and innovative ones: from the new **primary heat-exchanger in stainless steel**, to the **new touchpad interface** up to the **hydraulic DIN connections**.

With CIAO X Beretta enhances the research of **higher comfort and innovation** in the respect of the environment, which has always represented one of the assets of the brand, since its origins. This **renewed energy consciousness** translates into high efficiency, low consumption and a high modulation ratio (1:8), that combined with the flexibility of installation, compact size and low weight, allow to place CIAO X at the top of its category.

But what's more, CIAO X thinks ahead for future generations. The new range **can already process a mixture of hydrogen up to 20%**, the sustainable energy source that will be the real ecological turning point in the coming years.

THE RANGE

Ciao X comes in a complete range of 5 models, to satisfy all heating requirements:

- **CIAO X 25 C** (combi models, with dedicated codes for natural gas and LPG)
- **CIAO X 30 C** (combi model)
- **CIAO X 15 R** (heating only model)
- **CIAO X 25 R** (heating only model)

The compact size and low weight of CIAO X, allow it to be installed anywhere in the house, even in a kitchen cupboard. The product is also suitable for recessed installation in a box or for outdoor installation in partially protected places.







CONTROL YOUR COMFORT BY A TOUCH

One of the main distinguishing characteristics of the new CIAO X is the **digital touchpad interface**, combining **innovative design and features** with **user-friendliness**. By a simple touch on 7 points of the panel, it is possible to access in an intuitive way all the settings and parameters of the boiler and the system.

Each touch activates a **buzzer**, that generates an acoustic feedback as a confirmation of the operation.

The **LCD display** communicates with the user and installer through **icons, without using texts**, so as to allow an immediate understanding of the displayed function.

COMMUNICATION THROUGH ICONS

	DHW request ongoing		Generic alarm
	CH water pressure alarm		Maintenance - flashing with bell icon for alarm
	CH request ongoing		Flame presence or flame block



Navigation directions > <

Navigation directions ^ v

Domestic Hot Water temperature setpoint regulation +/-

Central Heating temperature setpoint regulation +/-

Boiler operation status (OFF/SUMMER/WINTER)

RESET of any alarm status/ Vent cycle interruption

INFO/ ENTER/ Parameters MENU



EVERYWHERE CIAO X

CIAO X features a **modern and linear design**, which blends easily into any setting.

The **compact dimensions and low weight** allow the product to be easily installed anywhere, not only inside the house, but also recessed in box or outdoors, in a partially protected space. CIAO X is therefore also ideal for the replacement of old boilers, both with DIN or with

Beretta connection sequence, thanks to the availability of accessory kits that simplify the conversion.

A wide range of accessories complete the offer of CIAO X: **flue kit**, **compact water filters** (softener and magnetic) and **hydraulic connections cover**, making installation easier and harmonising integration in both indoor and outdoor environments.



**UNIVERSAL
INSTALLATION**

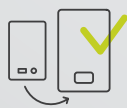

**EASE OF
REPLACEMENT**



**EASE OF
INTEGRATION**



Hydraulic
connections cover

TECHNOLOGY AND ENERGY-SAVING HAND-IN-HAND

NEW CONDENSING HEAT EXCHANGER

CIAO X features a high efficiency **condensing heat exchanger in stainless steel**, compact and robust. It is made of a **coiled smooth tube with a large section, ensuring optimized efficiency of the combustion and cleanness over time**. The stainless-steel quality provides **high resistance to corrosion**, deriving from acid condensate. The large section of the tube and its geometry as a unique coil ensure a constant flow and prevent intrinsically from clogging. The **frontal access to heat exchanger** enables ease of maintenance and cleaning of the combustion chamber.

NEW FUNCTIONS FOR A HIGHER DHW COMFORT

In the combi models, the high-performance plate heat exchanger, developed by Beretta, connected to the primary circuit of the hot water, allows to warm up the DHW in an instantaneous way, without the need of any external tank.

The **new optimized heat-exchanger** has been conceived to obtain the **best performance and maximum comfort for the end-user in terms of temperature stability and reduced waiting times**. These pluses, which place the product at the top of its category, translate finally into **respect for the environment, saving water and energy**.

› PRE-HEATING AND ITS EVOLUTION INTO SMART PRE-HEATING

have been conceived in order to further save water and gas consumption. They allow, in fact, to keep warm the water inside the new high efficiency plate heat exchanger, produced in our plants, to reduce waiting time.

› **TOUCH & GO** allows to activate an instantaneous pre-heating, only for one specific request.

› Other special functions like **DHW DELAY, NO-OSCILLATION PERFORMANCE, SMART FAN** allow to upgrade the boiler performance in particularly difficult operation conditions like e.g. very low or very high inlet water temperature or very low water flow.

LOW NOISE OPERATION

This feature makes CIAO X ideal for installation indoor, even for replacement in a kitchen.



STAINLESS STEEL HEAT EXCHANGER



FRONTAL ACCESS TO COMPONENTS



DURABILITY



ENERGY-SAVING



QUICK AND STABLE HOT WATER



REDUCED WAITING TIMES



LOW NOISE OPERATION

➤ **NEW CONDENSING HEAT EXCHANGER IN STAINLESS STEEL WITH FRONTAL ACCESS**

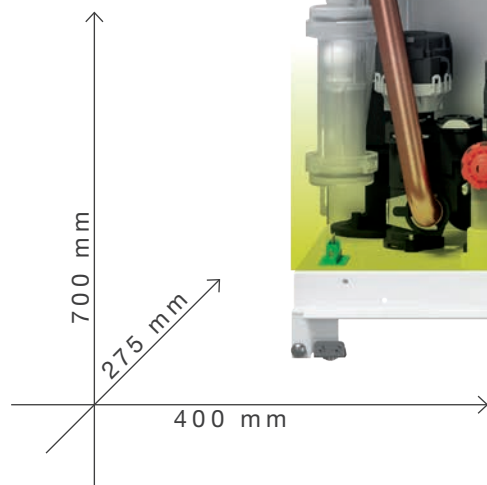

➤ **NEW HYDRAULIC GROUP WITH DIN CONNECTIONS**

➤ **HIGH MODULATION RANGE:**
8:1 PREMIX MODULATION RATIO

➤ **LOW NOx:** CLASS 6 (EN 15502)

➤ **BUILT-IN THERMOREGULATION** WITH EXTERNAL PROBE AVAILABLE AS AN ACCESSORY

➤ **RANGE RATED CERTIFICATION** TO ADAPT THE POWER OF THE BOILER TO THE REAL THERMAL REQUESTS OF THE INSTALLATION

➤ **IPX5D** ELECTRICAL PROTECTION

➤ **NEW FLUE FLANGE** FEATURING FAST AND SAFE **QUICK-FASTENING CONNECTION** AND INTEGRATED **FLUES ANALYSIS INLET**

➤ **LOW ENERGY CIRCULATOR** ($EEI \leq 0,20$): 6 M RESIDUAL HEAD

➤ **HYDRAULIC CONNECTIONS COVER** AND A WIDE RANGE OF ACCESSORIES AVAILABLE AS OPTIONAL

➤ **COMPATIBLE WITH THE OFFER OF BERETTA SMART THERMOSTATS**, BOTH AS ON/OFF OR AS WI-FI THERMOSTATS IN OTBUS COMMUNICATION

A GREEN FUTURE STARTING TODAY

CIAO X is born now, thinking of tomorrow. The new condensing range, in fact, is **designed to operate with mixtures of natural gas and hydrogen - up to 20%** - in line with the environmental sustainability objectives and the decarbonisation process started by the European Union.



HYDROGEN, THE SUSTAINABLE ENERGY SOURCE OF THE FUTURE

THE CYCLE OF HYDROGEN USE

Hydrogen is a safe and clean gas, available in huge quantities in nature. Mixed with natural gas up to a ratio of 20 to 80%, hydrogen allows to generate heat and hot water, helping to minimise polluting emissions. From the combustion of oxygen and hydrogen, and in the amount of the latter, water vapour is generated: in this way hydrogen turns back to water, its most common source, and reintroduced into nature.

- Availability in huge quantities
- Production by low-impact and sustainable methods from renewable sources, such as wind, photovoltaics, and biomass energy.
- Reduction of pollutant emissions in the percentage of its use
- Real opportunity for change to start the decarbonisation process, fight global climate change, and improve the quality of air and life.

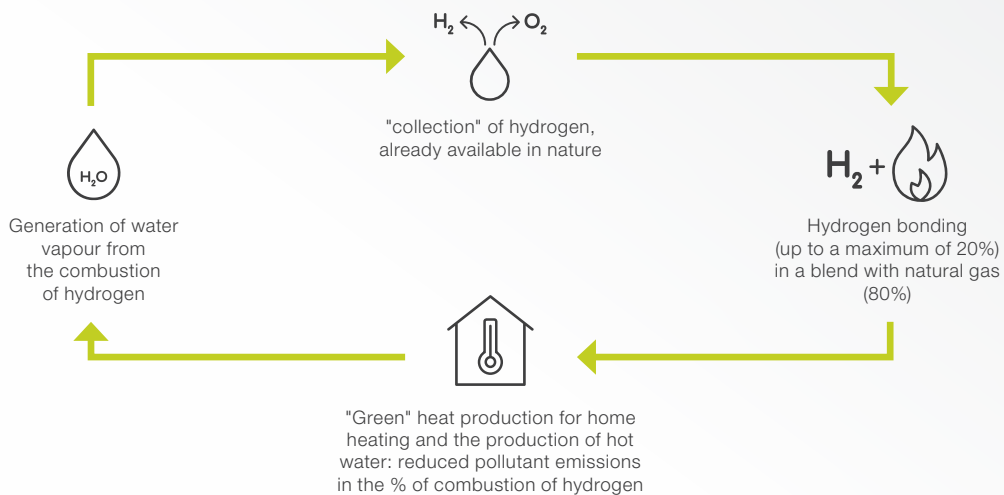



WITH CIAO X FOR A HEALTHY LIVING

Beretta, always engaged in designing solutions for heating and DHW comfort in the respect of the environment, enhances with CIAO X the **research of efficiency in the conscious use of energy sources and water**. The new range is the result of the development of innovative technologies and functions that allow energy

saving, to ensure a “green” comfort. CIAO X modern technology and the possibility to remotely control it by the end-user imply a benefit for the environment that translates into **cost savings for the user**.

TECHNICAL DRAWINGS

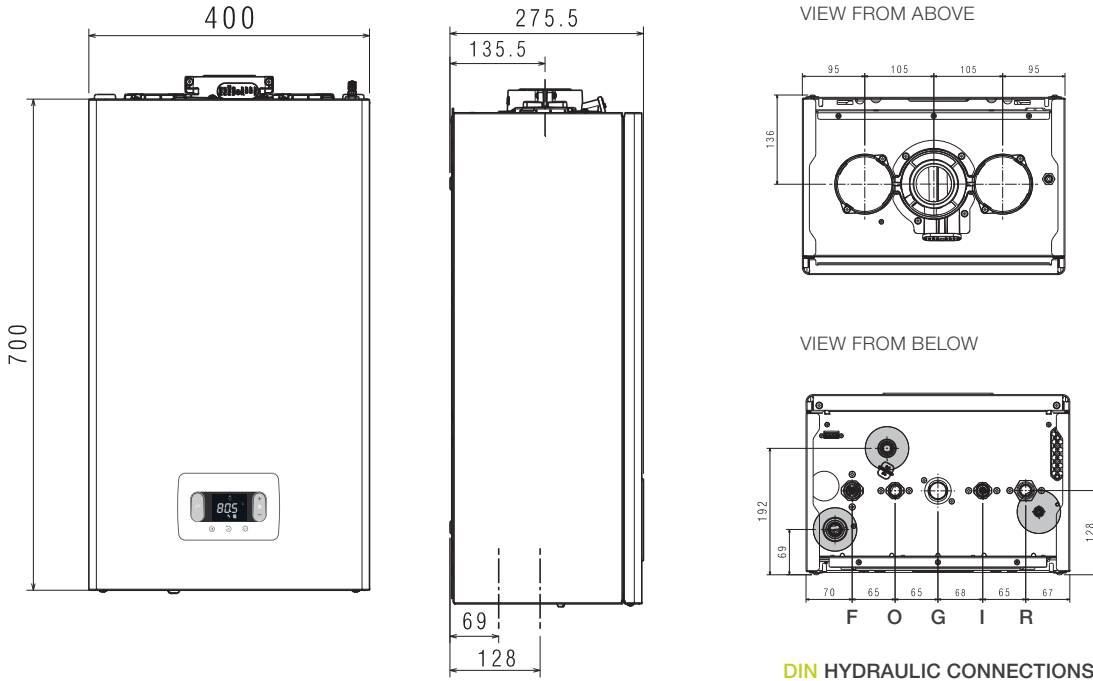

DIN HYDRAULIC CONNECTIONS

RETURN **R**
 DCW INLET **I**
 GAS **G**
 DHW OUTLET **O**
 FLOW **F**

FLUE OPTIONS

- › FLANGE INSTALLED AS STANDARD
- › QUICK INSTALLATION WITHOUT THE NEED FOR AN EXTERNAL COLLAR
- › BOILER DEPARTURE WITH BERETTA SPECIFIC FLUE OPTIONS

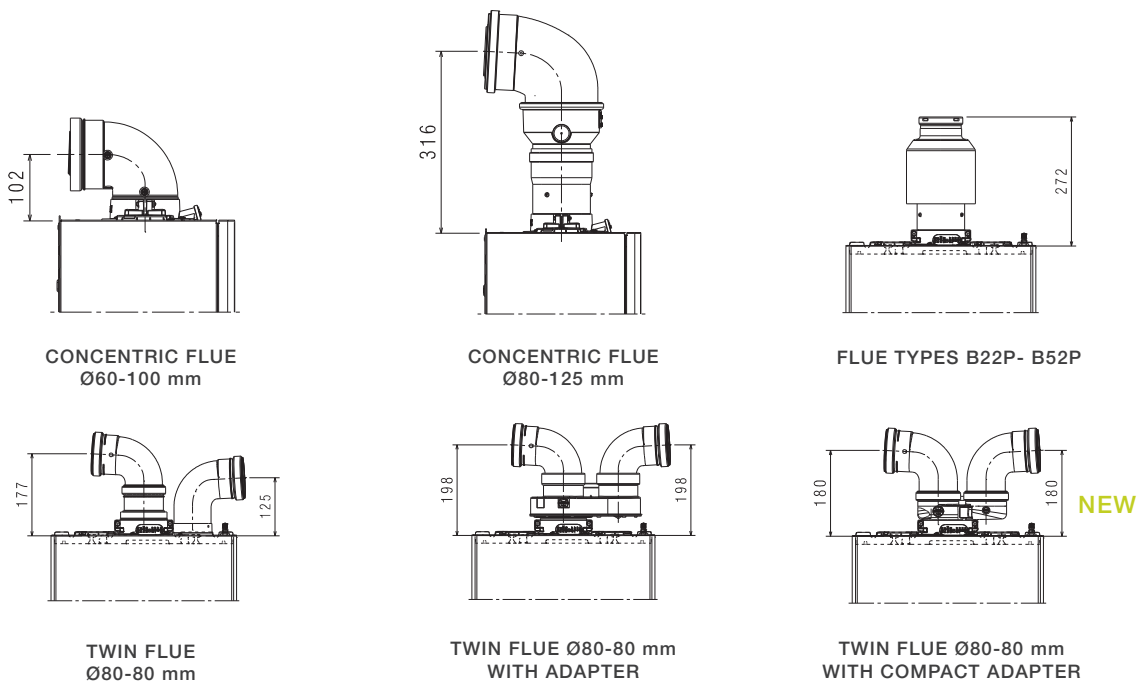

TECHNICAL DATA



ENERGY LABELLING SPECIFICATIONS (according to ErP regulations)

	UOM	25 C	30 C	15 R ^(*)	25 R ^(*)
Boiler order code (supply NG)		20187761	20187765	20187766	20187767
Boiler order code (supply LPG)		20187764	/	/	/
Seasonal space heating energy efficiency class		A	A	A	A
Water heating energy efficiency class		A	A	-	-
Rated heat output	pnominal kW	19	24	15	19
Seasonal space heating energy efficiency	ηs %	93	93	93	93
USEFUL HEAT OUTPUT					
At rated heat output, high-temperature regime (**)	P4 kW	19,4	24,4	14,5	19,4
At 30% of rated heat output and low-temperature regime (***)	P1 kW	6,5	8,2	4,9	6,5
USEFUL EFFICIENCY					
At rated heat output and high-temperature regime (**)	η4 %	87,3	87,6	87,1	87,3
At 30% of rated heat output and low-temperature regime (***)	η1 %	98,5	98,2	98,7	98,5
AUXILIARY ELECTRICITY CONSUMPTION					
At full load	elmax W	32	38	32	32
At part load	elmin W	12	12	12	12
In Stand-by mode	PSB W	3	3	3	3
OTHER PARAMETERS					
Stand-by heat losses	Pstby W	30	30	30	30
Annual energy consumption	QHE GJ	42	56	42	42
Sound power level, indoors	LWA dB	50	53	50	50
NOx emissions	NOx mg/kWh	22	22	22	22
FOR COMBINATION HEATERS					
Declared load profile		XL	XL	-	-
DHW energy efficiency	ηwh %	84	84	-	-
Daily electricity consumption	Qelec kWh	0,133	0,152	-	-
Daily fuel consumption	Qfuel kWh	23,183	23,306	-	-
Annual electricity consumption	AEC kWh	29	33	-	-
Annual fuel consumption	AFC GJ	18	18	-	-
OTHER SPECIFICATIONS					
CH heat INPUT (max-min)	kW	20,0 - 3,1	25,0 - 3,95	15,00 - 3,1	20,0 - 3,1
DHW heat nominal INPUT (max-min)	kW	25,0 - 3,1	30,0 - 3,95	25,0 - 3,1	25,0 - 3,1
Power supply voltage	V-Hz	230 - 50	230 - 50	230 - 50	230 - 50
Degree of protection	IP	IPX5D	IPX5D	IPX5D	IPX5D
NOx class		6	6	6	6
CH					
Max pressure-temperature	bar-°C	3-90	3-90	3-90	3-90
Pump: max available head (flow rate 1000 l/h)	mbar	408	408	408	408
Membrane expansion tank	l	8	8	8	8
DHW					
Max pressure	bar	8	8	-	-
DHW production at ΔT = 25°C / 30°C / 35°C	l/min	14,3/11,9/10,2	17,2/14,3/12,3	-	-
DHW minimum flow rate	l/min	2	2	-	-
HYDRAULIC AND GAS CONNECTIONS					
Inlet gas pressure (G20-G31)	mbar	20-37	20-37	20 -37	20 -37
CH Flow - Return / Gas inlet	Ø	3/4"	3/4"	3/4"	3/4"
DHW Inlet - Outlet / DHW tank Flow - Return	Ø	1/2"	1/2"	3/4"	1/2"
DIMENSIONS, WEIGHT					
Boiler dimensions (HxWxD)	mm	700x400x275	700x400x275	700x400x275	700x400x275
Net weight	kg	28,5	30	27,5	29
FLUE OPTIONS AND LENGTHS					
Max length for concentric flue (Ø 60 -100mm)	m	5,85	4,85	5,85	5,85
Max length for twin flue (Ø 80 + 80 mm)	m	33+33 ^(A)	27+27 ^(B)	33+33 ^(A)	33+33 ^(A)

(*) The 'Only heating' models are supplied with a three-ways valve. Filling tap is not available.

(**) High-temperature regime means: 60°C Return and 80°C Flow of the boiler.

(***) Low temperature regime means for condensing boilers 30°C, for low-temperature boilers 37°C and for other heaters 50°C return temperature (at heater inlet).

(A) Up to 52+52 via twin flue adapter with air inlet swelling position (available as an accessory)

(B) Up to 45+45 via twin flue adapter with air inlet swelling position (available as an accessory)



RIELLO S.p.A.

Via Ing. Pilade Riello, 7,
37045 Legnago (Italy)
tel. +39 0442 630111
www.berettaheating.com

In order to improve its products, Beretta reserves the right to modify the characteristics and information contained in this catalogue at any time and without prior notice. This catalogue, therefore, cannot be considered as contractually binding on third parties.

code 27018966 EN 10.2021

 **Beretta**