

---

Wall hung, fanflue, roomsealed, high efficiency gas boiler

# User manual and Installation instructions

## **BASICA COND**

Product name

**BASICA COND 28S**

Models

**M275V.28 SR**

G.C. Appl. No.

**41-583-40**



Congratulations on your choice.

The Biasi **BASICA COND** are condensing high efficiency sealed chamber fan flue gas boilers. They are fully electronically controlled and have electronic ignition.

The materials they are made of and the control systems they are equipped with give you safety, a high level of comfort and energy savings to allow you to get the greatest benefit out of independent heating.

The Biasi **BASICA COND** allow a higher efficiency by reducing the flue gas temperature such that the water vapour formed during the combustion is condensed out.

This allows a gain of useful heat that otherwise would be lost.



Biasi UK Ltd is a licensed member of the Benchmark Scheme which aims to improve the standards of installation and commissioning of domestic heating and hot water systems in the UK and to encourage regular servicing to optimise safety, efficiency and performance. Benchmark is managed and promoted by the Heating and Hot water Industry Council. For more information visit [www.hhic.co.uk](http://www.hhic.co.uk).



**DANGER:** The indications marked with this symbol must be observed to prevent accidents of mechanical or generic origin (e.g.: Injuries or bruises).



**DANGER:** The indications marked with this symbol must be observed to prevent accidents of electric origin (electrocution).



**DANGER:** The indications marked with this symbol must be observed to prevent the risk of fire or explosion.



**DANGER:** The indications marked with this symbol must be observed to prevent accidents of heat origin (burns).



**ATTENTION:** The indications marked with this symbol must be observed to prevent malfunctioning and/or damage to materials of the appliance or other objects.



**ATTENTION:** The indications marked with this symbol are important information that must be carefully read.



## Remember that...



WARNING

- ✓ **The manual** must be read thoroughly, so that you will be able to use the boiler in a safe and sensible way and must be carefully kept. It may be necessary for reference in the future.
- ✓ **The first firing** must be carried out by a competent and responsible Gas Safe engineer.
- ✓ **The manufacturer**
  - disclaims all liability for any translations of the present manual from which incorrect interpretation may occur;
  - cannot be held responsible for non-observance of instructions contained in this manual or for the consequences of any procedure not specifically described.

Please ensure that the installer has fully completed the Benchmark Checklist on the inside back pages of the installation instructions supplied with the product and that you have signed it to say that you have received a full and clear explanation of its operation. The installer is legally required to complete a commissioning checklist as a means of complying with the appropriate Building Regulations (England and Wales).

All installations must be notified to Local Area Building Control either directly or through a Competent Persons Scheme. A Building Regulations Compliance Certificate will then be issued to the customer who should, on receipt, write the Notification Number on the Benchmark Checklist.

This product should be serviced regularly to optimise its safety, efficiency and performance. The service engineer should complete the relevant Service Record on the Benchmark Checklist after each service.

The Benchmark Checklist will be required in the event of any warranty claim.

- ✓ **Before lighting the boiler** you are advised to have a Gas Safe Registered Engineer check that the installation of the gas supply is
  - gas-tight;
  - of the correct gauge for the flow to the boiler;
  - fitted with all the safety and control devices required by the current Regulations.
- ✓ **Ensure that**
  - if converting to a sealed system that the installer has connected and terminated a pressure relief valve in a manner which allows safe discharge and a pressure expansion vessel sized according to the system size. The manufacturers are not responsible for damage caused by opening of the pressure relief valve and consequent escape of water, if this is not connected and terminated.
  - the installer has connected and terminated the pressure relief valve in a manner which allows safe discharge. The manufacturers are not responsible for damage caused by opening of the pressure relief valve and consequent escape of water, if this is not connected and terminated.
  - the installer has connected the condensate outlet to a suitable drain pipe.

- 
- ✓ **On detecting the smell of gas:**
    - do not operate any electrical switches, the telephone or any device that may produce sparks;
    - open the windows and doors at once to create a draught of air which will purge the area;
    - shut off the gas cocks;
    - get the assistance of a qualified person. Emergency telephone number  
**Tel. 0800 111999.**
  - ✓ **Do not touch the appliance** with parts of the body that are wet or damp and/or bare feet.
  - ✓ **Do not block or modify** the condensate outlet and pipe work.
  - ✓ **In case of structural work** or maintenance near the flue and flue terminal turn off the appliance. On completion of the work, have a professionally qualified person check there efficiency.
  - ✓ **Repairs** (under guarantee) must be carried out only by a Biasi an approved engineer, using genuine spare parts. Thus do no more than switching off the boiler yourself (see the instructions).
  - ✓ **Your boiler** allows heating up of water to a temperature less than boiling point therefore it
    - must be connected to a central heating system and/or a hot water supply system, compatible with its performance and output;
    - can be used only for those purposes for which it has been specially designed;
    - must not be touched by children or by those unfamiliar with its operation;
    - must not be exposed to weather conditions.
  - ✓ **During the operation** it is quite normal that the boiler produces a white plume of condensation vapour from the flue terminal. This is due to the high efficiency of the appliance and may be particularly evident with low outdoor temperatures.

## Safe handling of substances

Biasi products are manufactured in accordance with ISO 9001 and do not, and will not, contain any hazardous materials or substances such as asbestos, mercury or C.F.C.'s. The appliance packaging does not contain any substances, which may be considered a hazard to health.

When handling or lifting always use safe techniques.

- Keep your back straight, bend your knees, don't twist.
- Move your feet, avoid bending forwards and side ways and keep the load as close to your body as possible.

Where possible transport the boiler using a sack truck or other suitable trolley. Always grip the boiler firmly, and before lifting feel where the weight is concentrated to establish the centre of gravity, repositioning yourself as necessary.

---

### Combustion chamber panels

*Material:* mineral fibres

*Known hazards* - Some people can suffer reddening and itching of the skin. Fibre entry into the eye will cause foreign body irritation, which can cause severe irritation to people wearing contact lenses. Irritation to respiratory tract.

*Precautions* - Dust goggles will protect eyes. People with a history of skin complaints may be particularly susceptible to irritation. High dust levels are only likely to arise following harsh abrasion. In general, normal handling and use will not present high risk. Follow good hygiene practices; wash hands before, touching eyes, consuming food, drinking or using the toilet.

*First aid* - Medical attention must be sought following eye contact or prolonged reddening of the skin.

### Sharp Edges

Caution should be taken when handling the boiler to avoid sharp edges on the boiler.

## Boiler installation and commissioning tips

- ✓ **The installation** must be carried out by a qualified Gas Safe Registered Engineer who will be responsible for observing the current Regulations and the completion of the Benchmark Gas Boiler System Commissioning Checklist, located at the back of this User manual.

---

## Installing the boiler...

- ✓ You must ensure that you remove the transit caps and plugs from the boiler connections which are fitted to every boiler.
- ✓ Keep the boiler clear of dust during installation and in particular do not allow any dust or debris to enter the top of the boiler where the flue connection is made. It is recommended that you put a dust sheet over the top of the boiler until you are ready to make the flue connection.
- ✓ Remember to release the auto air purge valve on the pump assembly before filling the boiler. See the instructions to identify the location of this device.
- ✓ This boiler allows you to control the flow temperature of the central heating system at very low levels. For underfloor heating system a temperature limiting device (e.g. a safety thermostat) is recommended to stop the boiler in case that the water temperature exceeds the design temperature.
- ✓ You are strongly advised to flush out the system both hot and cold in order to remove any system and installation debris to the British Standard BS 7593 code of practice.
- ✓ It is also sensible to initially fire and commission the boiler before connecting any external controls such as a room thermostat. By following this procedure, if you have a subsequent problem this method can eliminate the external controls from your fault analysis.
- ✓ Some products incorporate an anti cycling time delay. It is normal when first switching the boiler on for the boiler to operate on heating for a few seconds then switch off. After 3 - 4 minutes has elapsed the boiler will then re ignite and operate perfectly normally.
- ✓ If you are in any doubts as to the installation or operation of the boiler please read the instruction manuals thoroughly and then if necessary contact Biasi UK for advice and assistance.
- ✓ Guarantee conditions.  
The guarantee registration form must be returned within 30 days of purchase, failure to comply will invalidate the guarantee.  
Electrodes disclaimer. Note to service engineers: It is required that the burner seal, lip seal and mixing chamber seal along with the flame detection electrode are inspected every year and replaced every 24 months. Failure to inspect the flame detection probe, seals and replace as required may render the guarantee void.

Please remember that if you are in any doubt about the installation of this product you can contact our Technical Help line on tel. 01922 714 600.

**Appliance category:** II2H3P (gas G20 20 mbar, G31 37 mbar)

**Country of destination:** United Kingdom (GB) Ireland (IE)

This appliance conforms with the following EEC directive:

Regulation (EU) 2016/426 on appliances burning gaseous fuels

Efficiency Directive 92/42/EEC

Electromagnetic Compatibility Directive 2014/30/EU

Low Voltage Directive 2014/35/EU

Ecodesign Requirements Directive 2009/125/EC

The manufacturer, in the continuous process to improve his products, reserves the right to modify the data expressed in the present documentation at any time and without prior notice.

The present documentation is an informative support and it can not be considered as a contract towards third parties.

---

# TABLE OF CONTENTS

<b>1 APPLIANCE DESCRIPTION</b> . . . . .	<b>8</b>	<b>7 COMMISSIONING</b> . . . . .	<b>43</b>
1.1 Overview . . . . .	8	7.1 Warnings . . . . .	43
1.2 Isolation valves . . . . .	8	7.2 Electrical installation . . . . .	43
1.3 Control panel . . . . .	9	7.3 Gas supply installation . . . . .	43
1.4 LCD general features . . . . .	10	7.4 Initial filling of the system . . . . .	43
<b>2 INSTRUCTIONS FOR USE</b> . . . . .	<b>12</b>	7.5 Condensate pipe and traps . . . . .	45
2.1 Warnings . . . . .	12	7.6 Checking the gas supply pressure . . . . .	45
2.2 Refilling procedure . . . . .	12	7.7 Checking the inlet pressure . . . . .	45
2.3 Ignition . . . . .	13	7.8 Lighting the boiler . . . . .	46
2.4 C.H. circuit temperature . . . . .	14	7.9 Checking the ignition device . . . . .	47
2.5 Switching off . . . . .	15	7.10 Checking the flue system . . . . .	47
<b>3 USEFUL ADVICE</b> . . . . .	<b>16</b>	7.11 Checking the condensate drain pipe . . . . .	48
3.1 Central Heating . . . . .	16	7.12 Instructing the user . . . . .	48
3.2 Frost protection . . . . .	16	<b>8 ADVANCED COMMISSIONING</b> . . . . .	<b>49</b>
3.3 Condensate drain . . . . .	16	8.1 Access parameters for installer . . . . .	49
3.4 Periodic maintenance . . . . .	16	8.2 Enabling of operation with remote control (optional) . . . . .	49
3.5 External cleaning . . . . .	17	8.3 Setting the K coefficient of the external temperature probe . . . . .	50
3.6 Operational faults . . . . .	17	8.4 Selecting the maximum heating temperature setpoint with climatic curve set . . . . .	52
3.7 Displaying in INFO mode . . . . .	18	8.5 Selecting the heating temperature set . . . . .	53
3.8 Flue probe and safety thermal fuse . . . . .	19	8.6 Setting the pump post-circulation . . . . .	54
<b>4 TECHNICAL INFORMATION</b> . . . . .	<b>20</b>	8.7 Selecting the reignition frequency . . . . .	54
4.1 Overview . . . . .	20	8.8 Factory reset . . . . .	55
4.2 Main diagram . . . . .	21	8.9 Settings for changing the control board . . . . .	56
4.3 Hydraulic specifications . . . . .	23	<b>9 GAS CONVERSION</b> . . . . .	<b>60</b>
4.4 Expansion vessel . . . . .	23	9.1 Warnings . . . . .	60
4.5 Technical data BASICA COND 28S (M275V.28 SR) . . . . .	24	9.2 Operations and gas setting . . . . .	60
<b>5 GENERAL REQUIREMENTS</b> . . . . .	<b>27</b>	<b>10 MAINTENANCE</b> . . . . .	<b>62</b>
5.1 Related documents . . . . .	27	10.1 Warnings . . . . .	62
5.2 Location of appliance . . . . .	27	10.2 Programming the maintenance period . . . . .	62
5.3 Flue system . . . . .	28	10.3 Dismantling the external panels . . . . .	63
5.4 Gas supply . . . . .	29	10.4 Reassembly the external panels . . . . .	64
5.5 Air supply . . . . .	30	10.5 Emptying the C.H. system . . . . .	64
5.6 Ventilation . . . . .	30	10.6 Cleaning the condensing primary exchanger and the burner . . . . .	64
5.7 Condensate drain . . . . .	30	10.7 Check the pressure of the heating expansion vessel . . . . .	66
5.8 Water circulation (C.H.) . . . . .	31	10.8 Checking the flue system . . . . .	66
5.9 Water treatment . . . . .	32	10.9 Combustion analysis check . . . . .	66
5.10 Electrical supply . . . . .	32	10.10 Checking the condensate drain pipe . . . . .	67
<b>6 INSTALLATION</b> . . . . .	<b>33</b>	10.11 Visual inspection of appliance . . . . .	67
6.1 Warnings . . . . .	33	10.12 Checking the gas supply pressure . . . . .	67
6.2 Precautions for installation . . . . .	33	10.13 Water inhibitor concentration . . . . .	68
6.3 Installing the bracket . . . . .	34	10.14 Setting the boiler flue sweep function . . . . .	68
6.4 Overall dimensions . . . . .	35	<b>11 BENCHMARK COMMISSIONING &amp; WARRANTY VALIDATION SERVICE RECORD</b> . . . . .	<b>70</b>
6.5 Joints . . . . .	35	Gas boiler system commissioning checklist & warranty validation record . . . . .	71
6.6 Mounting the boiler . . . . .	35	Service & interim boiler work record . . . . .	72
6.7 Fitting the flue system . . . . .	36		
6.8 Choice of flue . . . . .	36		
6.9 Electric connection . . . . .	39		
6.10 Connecting the room thermostat or zone valves	40		
6.11 Installation of the external temperature probe . . . . .	41		
6.12 Electric connection between the boiler and the external probe . . . . .	41		
6.13 Remote electric connection (optional) . . . . .	41		
6.14 Example of hydraulic systems with hydraulic separator . . . . .	41		

## Abbreviations used in the manual:

C.H. = Central heating  
D.H.W. = Domestic hot water  
D.C.W. = Domestic cold water

# APPLIANCE DESCRIPTION

## 1 APPLIANCE DESCRIPTION

### 1.1 Overview

The model and serial number of the boiler is shown on the bottom of the boiler.

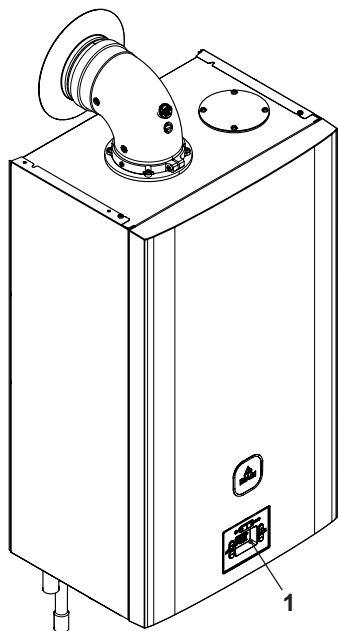

Fig. 1.1

- 1 Controls panel

### 1.2 Isolation valves

The figures in this manual only show one of the possible ways of installing cocks, pipes and fittings.

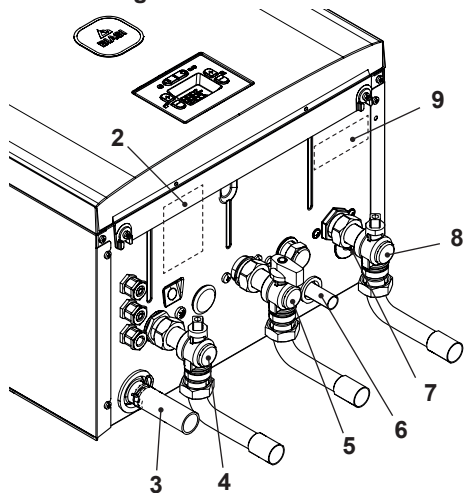

Fig. 1.2

- 2 Gas supply label
- 3 Condensate drain pipe
- 4 C.H. flow valve
- 5 Gas inlet valve
- 6 C.H. pressure relief valve pipe
- 7 Main circuit drain valve
- 8 C.H. return valve
- 9 Model and serial number of the boiler label



---

# APPLIANCE DESCRIPTION

---

## 1.3 Control panel

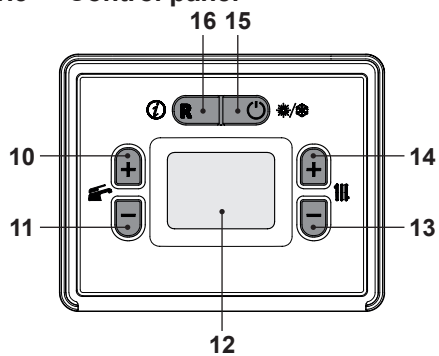

Fig. 1.3

- 10 Programming key
- 11 Programming key
- 12 LCD display
- 13 C.H. temperature reduce key
- 14 C.H. temperature increase key
- 15 Stand-by/Winter/Summer key
- 16 Reset key

# APPLIANCE DESCRIPTION

## 1.4 LCD general features

For the boiler technical information refer to the section "TECHNICAL INFORMATION" on page 20.

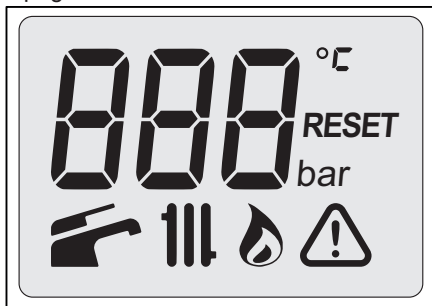

Fig. 1.4









### KEY







	The symbol indicates a volatile error. The boiler is reactivated automatically once the fault has been resolved
	The symbol indicates that the boiler can be restarted directly by the user by pressing the reset button
	Next maintenance period expiring. Enter the "INFO mode" to view the remaining weeks before maintenance is due
	All symbols with lines radiating from them indicate that the symbol is flashing

## SIGNAL DISPLAYED BY THE LCD

LCD	FUNCTION
<b>E01 + RESET</b>	Safety lockout due to failed ignition
<b>E02 + RESET</b>	Lockout due to safety thermostat
<b>E03 + RESET</b>	EEPROM error
<b>E04 + !</b>	Pump circulation failure or insufficient system pressure
<b>E05 + !</b>	Fan control anomaly
<b>E06 + !</b>	Heating NTC probe failure
<b>E07 + !</b>	DHW NTC probe failure
<b>E08 + !</b>	External NTC probe failure
<b>E09 + !</b>	Flue gas NTC probe failure (interruption)
<b>E10 + !</b>	Lockout due to tripping of the flue gas probe
<b>E11 + !</b>	Parasite flame
<b>E12 + !</b>	Return NTC probe failure
<b>E13 + !</b>	Central Heating pressure high
<b>E14 + !</b>	Temperature gradient circulation failure (>2K/s)
<b>E22 + RESET</b>	Heating delivery temperature between 90°C and 100°C
<b>E25 + !</b>	Boiler in antifreeze
<b>E26 + RESET</b>	Gas valve fault
<b>E28 + !</b>	Tank NTC probe failure
<b>E50 + !</b>	Communication with remote control lost
<b>E52 + RESET</b>	Maximum number of remote unlock attempts

## APPLIANCE DESCRIPTION

LCD	FUNCTION
<b>E54 + RESET</b>	Filling function of C.H. water completed, but pressure is lower than the minimum pressure for boiler filling
<b>E58 + RESET</b>	Filling function of C.H. water completed, but pressure is higher than the maximum pressure for boiler filling
<b>OFF</b>	Boiler off, (antifreeze protection active)
	Boiler in winter (heating/DHW) and stand-by
	Boiler in summer (DHW only) and stand-by
	Boiler with DHW power request. The DHW temperature is displayed.
	Boiler with heating power request. The temperature of the primary heating circuit is displayed.
	Burner ignition (discharge)
	Flame detected (burner ignited)
	Boiler in DHW anti-freeze phase (the  symbol flashes)

LCD	FUNCTION
	Boiler in heating anti-freeze phase (the  symbol flashes)
	Heating set temperature (all other symbols are disabled)
	DHW set temperature (all other symbols are disabled)
	Boiler in chimney sweep function. To activate the chimney sweep function, set "parameter P06≠0". 1 = minimum power 2 = maximum power  During the chimney sweep function, the  and/or  symbols do not flash.

USE

# INSTRUCTIONS FOR USE

## 2 INSTRUCTIONS FOR USE

### 2.1 Warnings

Biasi UK Ltd support the Benchmark initiative. The Benchmark Checklist is located at the back of this manual and should be completed by the Installing/Commissioning Engineer and handed over to the User for future reference by other visiting Engineers.

Also included is the Service Interval Record card that should be completed by the Service Engineer following the annual service maintenance of the boiler and system.

All Gas Safe Registered Installers carry a Gas Safe ID card, and have a registration number. Both should be recorded in your Benchmark Checklist. You can check your Installer is registered by calling Gas Safe direct on 0800 408 5500, or go on line at [www.GasSafeRegister.co.uk](http://www.GasSafeRegister.co.uk).

In order to guarantee safety and correct operation, it is essential that all the tests are carried out by a competent and responsible service engineer before lighting up the boiler.

The tests are described in the installation instructions in section 7 commissioning.

Ensure that the C.H. circuit is regularly filled with water.

**If you are in any doubt regarding this procedure you are advised to contact your Installer or an Approved Engineer.**

This appliance is provided with a built in anti-freeze system that operates the boiler when the temperature is below 5 °C.

Therefore, when the boiler is not lit or used in cold weather, with consequent risk of freezing do not switch off the boiler at the fused spur isolation switch or close the gas inlet cock.



In a non permanent live connection format this option will not function. An alternative solution can be an external frost thermostat connected through your wiring center.

When you do not expect to use the boiler for a long period and the boiler is not to be used for frost protection then follow the instructions given in section "Switching off" on page 15.

**If you experience any difficulty with the operation of the boiler, switch off the boiler immediately at the fused spur isolation switch and contact your Installer or an approved Service Engineer.**

You may find it necessary to vent air from your radiator circuit using your radiator key.

### 2.2 Refilling procedure

- Isolate the boiler from the electrical supply at the fused spur. Reconnect the filling loop as demonstrated in Fig. 2.1.

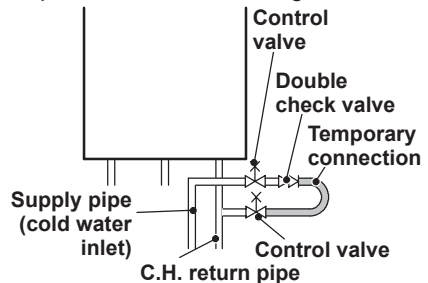

Fig. 2.1

- To access INFO mode, press 16 (Fig. 2.2) and hold for 5 seconds until the code **n02** shows on the display (Fig. 2.3).

# INSTRUCTIONS FOR USE

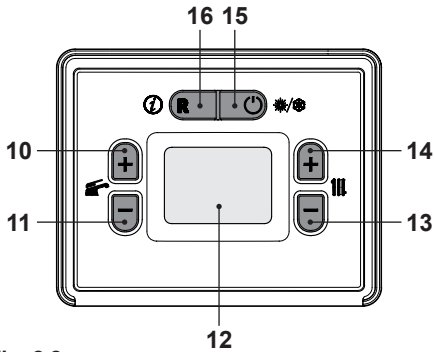

Fig. 2.2



Fig. 2.3

- Press button 10 (increase) to scroll through the values until the display shows code **n10** "central heating water pressure" appears on the display and the pressure value 1.3 bar (Fig. 2.4).



Fig. 2.4

- Open the valves on the filling loop and, at the same time, check the heating circuit pressure on the display. The pressure must be between 1 bar and

1.5 bar (e.g. 1.3 bar in (Fig. 2.4)).

Once done, close the valves on the filling loop.

**If you experience any difficulty with the operation of the boiler, switch off the boiler immediately at the fused spur isolation switch and contact your Installer or an approved Service Engineer.**

Air introduced into the boiler during this filling process will vent through the automatic air purger fitted to the boiler. You may also find it necessary to vent air from your radiator circuit using your radiator key, however be aware that excessive venting will cause the pressure in the system to drop.

Always ensure that the pressure is set at the required pressure.

## 2.3 Ignition

- Check that the valves located in the lower part of the boiler are open Fig. 2.5.

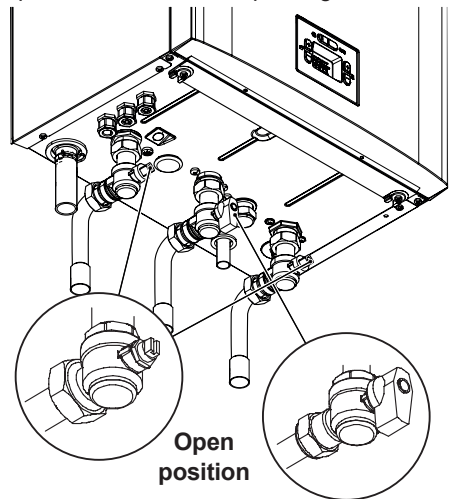

Fig. 2.5

- Power the boiler by turning on the two-

USE

# INSTRUCTIONS FOR USE

way switch fitted during installation. The LCD display shows the **OFF** status (only the heating antifreeze functions is active) Fig. 2.6.



Fig. 2.6

## C.H. functioning

- Press the key 15 and hold until both  symbol appear on the display Fig. 2.7.

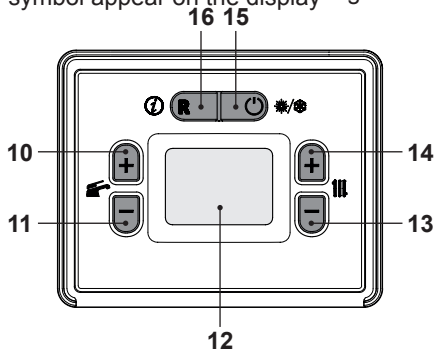



Fig. 2.7

The LCD display shows the stand-by status and the  symbol Fig. 2.8.

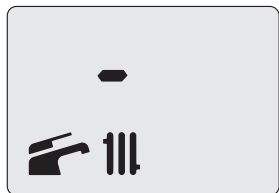

Fig. 2.8

## 2.4 C.H. circuit temperature

The output temperature of C.H. water can be adjusted by pressing keys 13 (reduce) and 14 (increase) (Fig. 2.7) from a minimum

of about 25°C to a maximum of about 85°C or from a minimum of about 50°C to a maximum of about 80°C or from a minimum of about 25°C to a maximum of about 55°C (see "Selecting the heating temperature set" on page 53). Press one of the two keys once to display the "set" value. Press again to access the modification.

Signal given by the LCD display:

- The heating flow "set" temperature and the symbol  flash. The background of the display is illuminated (Fig. 2.9).



Fig. 2.9

## Adjustment of temperature WITHOUT the external temperature probe (optional) fitted



Adjust the C.H. water flow as follows:

- from 25 to 35 with an external temperature included between 5 and 15°C
- from 35 to 60 with an external temperature included between -5 and +5°C
- from 60 to 80 with an external temperature less than -5°C.

Your installer can recommend the best suited settings for your heating system.

The set temperature has been reached when the  symbol is not visible on the LCD display.

## Power request in C.H. power.

When the boiler has a call for heat in the C.H. mode, the  symbol is displayed on the display followed by an increase of the C.H. water flow temperature. The  symbol flashes (Fig. 2.10).

# INSTRUCTIONS FOR USE

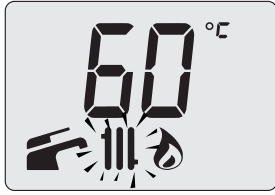

Fig. 2.10

## Adjusting the C.H. temperature with the external temp. probe installed

When the external temp. probe (optional) is installed your boiler automatically adjusts the temperature of the C.H. system water flow in relation to the external temperature. In this case the boiler must be set by a qualified installer (see "Setting the K coefficient of the external temperature probe" on page 50).

However, if the ambient temperature is not comfortable, the flow temperature of the heating system can be adjusted by  $\pm 15^{\circ}\text{C}$  by pressing on keys 13 (reduce) and 14 (increase) (Fig. 2.7).

## 2.5 Switching off

Press the key 15 (Fig. 2.11) until the message **OFF** appears on the LCD display (Fig. 2.12).

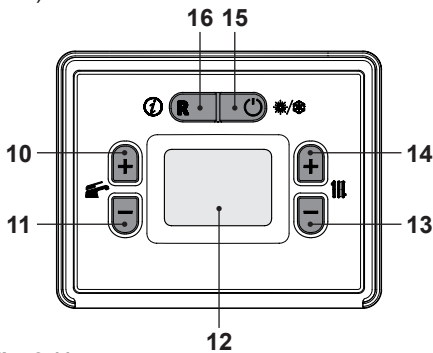

Fig. 2.11

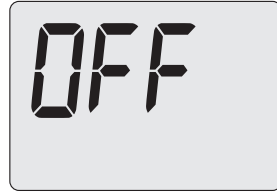

Fig. 2.12

In **OFF** mode, the antifreeze protection is active.

If a long period of inactivity is envisioned:

- Switch off the electricity supply to the boiler, by means of the fused spur isolation switch;
- Shut off the gas supply cock and the valves for the water circuits fitted under the boiler Fig. 2.13;

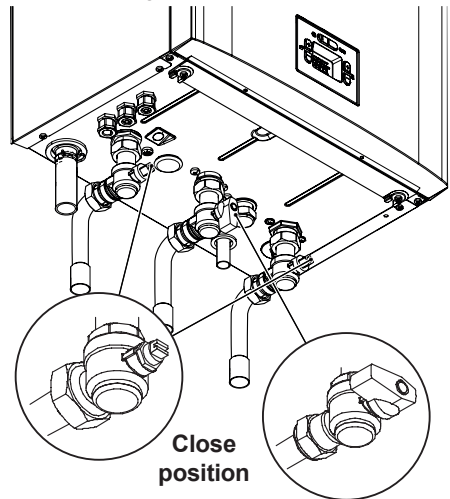

Fig. 2.13

- If necessary, empty the hydraulic circuits see section "Emptying the C.H. system" on page 64.

## USEFUL ADVICE

### 3 USEFUL ADVICE

#### 3.1 Central Heating

For your comfort and added system control, you can install a room thermostat but you should not shut off the radiator in that room or have a TRV fitted on the radiator.

If a radiator (or a convector) does not heat up, check that no air is present in it and that its valve is open. If the ambient temperature is too high, do not alter the radiator valves. Reduce the central heating temperature instead by means of the room thermostat or by pressing the 13 and 14 heating adjustment keys (Fig. 3.1).

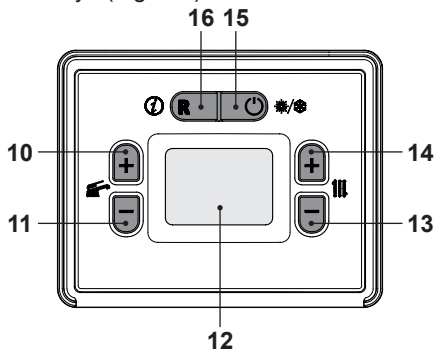

Fig. 3.1

#### 3.2 Frost protection

The built in anti frost system protects the boiler from frost damage but does not provide any protection for the system, an optional external frost protection thermostat can be added and a dedicated connection point is available on the electrical connection block.

The antifreeze function is active even if the boiler is in **OFF** (Fig. 3.2).



Fig. 3.2

Therefore, when the boiler is not lit and used in cold weather, with consequent risk of freezing do not switch off the boiler at the fused spur isolation switch or close the gas inlet cock.

If the boiler is deactivated, have a qualified technician empty the boiler (heating circuit), the C.H. system.

#### 3.3 Condensate drain

The condensate drain must not be modified or blocked. Blockage of the condensate drain, caused by debris or freezing, can cause automatic shutdown of the boiler. If freezing is suspected and the pipe run is accessible an attempt may be made to free the obstruction by pouring hot water over the exposed pipe and cleaning any blockage from the end of the pipe.

If this fails to remedy the problem the assistance of a Gas Safe registered installer or in IE a competent person should be sought.

#### 3.4 Periodic maintenance

For efficient and continuous operation of the boiler, it is advisable to arrange maintenance and cleaning by an Authorised Service Centre Engineer, at least once a year. During the service, the most important components of the boiler will be inspected and cleaned. This service can be part of a maintenance contract. In particular, you are advised to have the following checks carried out:

- condensing heat exchanger;



## USEFUL ADVICE

- burner;
- exhaust fume duct and flue;
- pressurisation of the expansion tank;
- filling up of the central heating circuit;
- bleeding of air from the central heating system;
- general check of the appliance's operation.

Please refer to the servicing information on section "MAINTENANCE" on page 62.

### 3.5 External cleaning

**Before carrying out any cleaning, disconnect the appliance from the electrical mains, using the fused spur isolation switch fitted adjacent to the appliance.**

To clean the external panels, use a cloth soaked in soapy water. Do not use solvents, abrasive powders or sponges.

**Do not** carry out cleaning of the appliance and/or its parts with readily flammable substances (for example petrol, alcohols, naphtha, etc.).

### 3.6 Operational faults

If the boiler is not working and an error code flashes on the display and the  symbol is shown, it is a volatile lockout. The boiler is reactivated automatically once the fault has been resolved (see "LCD general features" on page 10); the boiler is in lockout mode. The display background flashes (Fig. 3.3).



Fig. 3.3



Each fault is classified according to the level of priority. If more than one faults are detected at the same time, the most urgent error code is shown.



Frequent safety lockouts should be reported to an authorised service centre.

### Other operational faults signalled on the LCD display

If an error code, the  symbol and the **RESET** symbol are shown on the LCD display, the lockout is NOT volatile (Fig. 3.4).

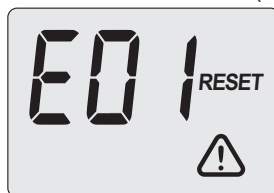

Fig. 3.4

To restore operation, press the reset button 16 (Fig. 3.1) on the boiler control panel.

### Noise due to air bubbles are heard during operation

You should check that the pressure on the pressure gauge is not below the correct setting.

If required, top up the system correctly, as described in the section "Refilling procedure" on page 12 of this manual. Bleed any air present in the radiators, if necessary.

### The pressure has gone down

It is necessary to top up the appliance with water again, so as to raise the pressure to an adequate level as described in the section "Refilling procedure" on page 12 of this manual. If topping up with water has to be done very frequently, have the system checked for leaks.

## USEFUL ADVICE

### Water comes out of the pressure relief valve

Check if the filling cock is closed tightly (see "Refilling procedure" on page 12).

Check on the pressure gauge that the pressure in the central heating circuit is not close to 3 bars. In this case, temperature rise in the circuit can cause the pressure relief valve to open. So that this does not happen and to decrease the pressure to a normal value, it is advisable to vent some of the water in the appliance through the bleed valves present in the radiators.

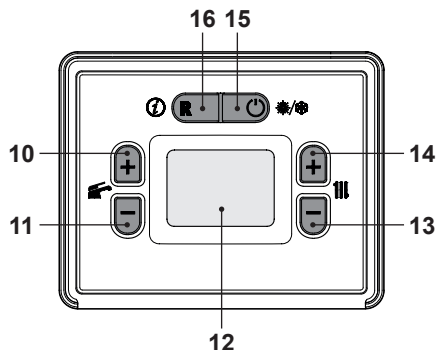

Fig. 3.5



Fig. 3.6

### Should occasionally leak from the boiler

Shut off the valves positioned under the boiler to page 15 and call an Authorised Service Centre Engineer.



**In this case or in case of problems other than those mentioned here, switch off the boiler, as described in section "Switching off" on page 15 and call a competent and responsible Service Engineer.**

### 3.7 Displaying in INFO mode

The INFO mode allows the display of some information on the boiler functioning status. In case of malfunctioning of the boiler, it may be useful to communicate such information to the Authorised Service Centre Engineer so that the causes can be understood.

To access INFO mode, press key 16 (Fig. 3.5) and hold for 5 seconds until the code **n02** shows on the display (Fig. 3.6).

To scroll the values press 10 (previous INFO) and 11 (next INFO) keys.

To exit INFO mode, either:

- press and hold the 15 key for 5 seconds (Fig. 3.5) (one level up).

The table summarises the possible values visible in INFO mode.

Table of contents	Value shown
<b>n02</b>	DHW output temp.
<b>n03</b>	NTC return temperature (not present)
<b>n04</b>	Flue gas temperature (not present)
<b>n05</b>	Outdoor temperature
<b>n08</b>	Maximum set fan speed (RPM/100)
<b>n10</b>	Central heating water pressure

## USEFUL ADVICE

n09	(not used)
n11	Flow rate
n14	PWM pump speed percentage
n15	Fan speed (RPM/100)
n20	(not used)
n21	Last error code
n22	Second-to-last error code
n26	Calculated heating set point (with climatic curve or configured set)
n29	Number of weeks to maintenance

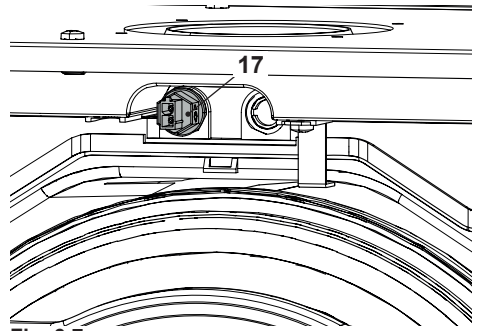

Fig. 3.7

### 3.8 Flue probe and safety thermal fuse



If the flue thermal cut-off fuse is triggered, the boiler goes into safety lockout. To restore normal boiler operation, please contact an Authorized Service Centre.

The flue probe and safety thermal fuse 17 indicated in Fig. 3.7 are a safety device. The flue probe 17 intervenes when the flue temperature exceeds 110°C placing the boiler in safety block switching it off.

To reset normal boiler functioning, just press the 15 (Fig. 3.5) key.

If flue probe 17 does not intervene and, therefore does not send the boiler into security lockout, flue thermal fuse 17 is triggered as an additional safety device to protect the flue outlet pipe.

To restore the normal operation of the boiler, contact the Authorized Service Centre.

# TECHNICAL INFORMATION

## 4 TECHNICAL INFORMATION

### 4.1 Overview

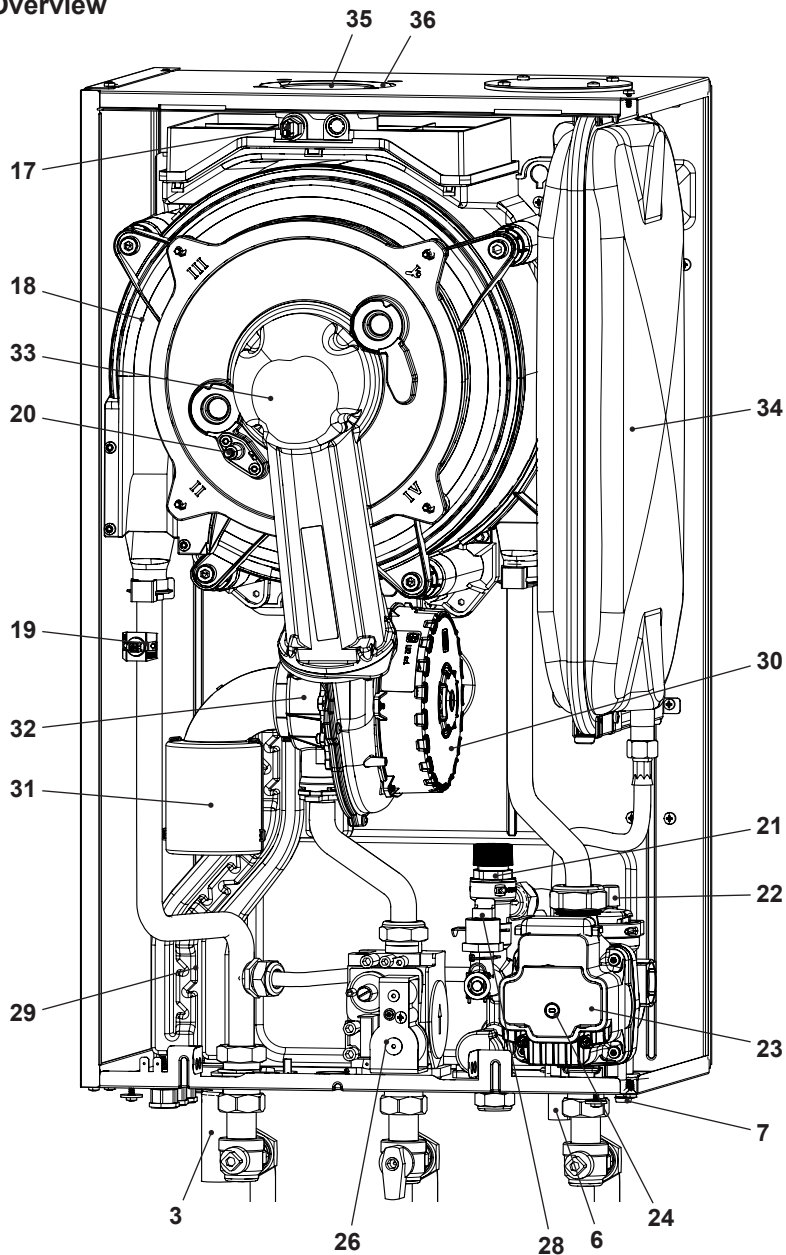

Fig. 4.1

# TECHNICAL INFORMATION

## 4.2 Main diagram

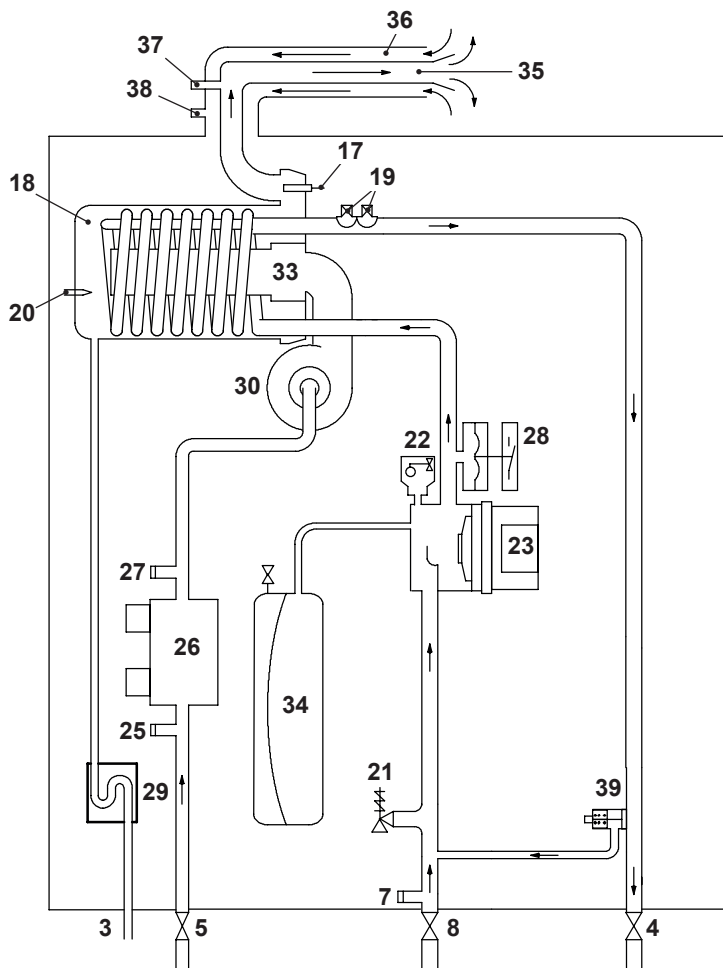

Fig. 4.2

- |    |  |    |  |
|----|--|----|--|
| 3  | Condensate drain pipe                              | 19 | NTC heating delivery probe - NTC maximum temperature |
| 4  | C.H. flow valve                                    | 20 | Flame-detecting electrode/ignition electrode         |
| 5  | Gas inlet valve                                    | 21 | C.H. pressure relief valve                           |
| 6  | C.H. pressure relief valve pipe                    | 22 | Automatic air purger valve                           |
| 7  | Main circuit drain valve                           | 23 | Pump   |
| 8  | C.H. return valve                                  | 24 | Pump vent plug                                       |
| 17 | Flue temperature probe NTC and Safety thermal fuse | 25 | Gas valve inlet test point                           |
| 18 | Condensing heat exchanger                          |    |  |

---

## TECHNICAL INFORMATION

---

- 26 Gas valve
- 27 Gas valve outlet test point
- 28 Primary circuit pressure switch
- 29 Condensate trap
- 30 Fan
- 31 Air manifold
- 32 Air/gas mixer
- 33 Burner
- 34 C.H. expansion tank
- 35 Flue outlet pipe
- 36 Air intake pipe
- 37 Flue exhaust sampling point
- 38 Air sampling point
- 39 By-pass valve

# TECHNICAL INFORMATION

## 4.3 Hydraulic specifications

The hydraulic specifications represents the pressure (available head for the central heating system) as a function of the flow rate.

### Model **BASICA COND 28S (M275V.28 SR)**

Pressure (bar)

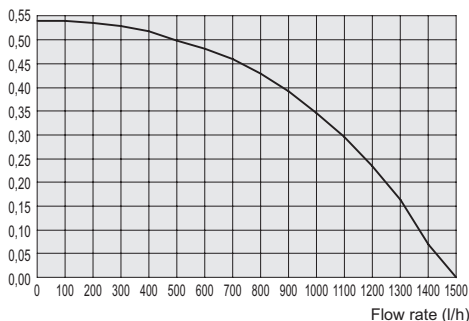

Fig. 4.3

The boiler load loss has already been removed.

### Flow rate with closed thermostatic valves

The boiler is equipped with an automatic by-pass, which protects the condensing primary exchanger.

In case of excessive reduction or total stopping of water circulation in the heating system due to the closing of thermostatic valves or circuit elements valves, the by-pass ensures a minimum water circulation inside the condensing primary exchanger.

The by-pass is calibrated to a differential pressure of about 0.3-0.4 bar.

## 4.4 Expansion vessel

**Note: this boiler is designed for operation only in a sealed central heating system.**

The height difference between the pressure relief valve and the highest point in the system may be 10 m at most.

For greater differences, increase the pre-load pressure in the expansion vessel and the system, when cold, by 0.1 bar for each additional 1 m.

Total capacity	l	7,0
Pre-load pressure	kPa	100
	bar	1,0
Useful capacity	l	3,5
Maximum volume of water in the system *	l	109

Fig. 4.4

\* Where conditions are:

- Average maximum temperature of the system is 85 °C
- Initial temperature when filling up the system is 10 °C

**!** For systems with volumes greater then the one indicated in the above table, an additional expansion vessel must be provided.

# TECHNICAL INFORMATION

## 4.5 Technical data BASICA COND 28S (M275V.28 SR)

Heat input		
Nominal net <sup>(A)</sup>	kW	27,5
	BTU/h	93834
Nominal gross <sup>(B)</sup>	kW	30,5
	BTU/h	104156
Minimum net <sup>(A)</sup>	kW	6,2
	BTU/h	21155
Minimum gross <sup>(B)</sup>	kW	6,9
	BTU/h	23482

Useful output		
Maximum	kW	27,0
	BTU/h	92128
Minimum	kW	5,8
	BTU/h	19790
Maximum condensing	kW	29,9
	BTU/h	102023
Minimum condensing	kW	6,6
	BTU/h	22520

Central heating		
Min/Max flow temperature settings*	°C	25-85
Maximum pressure	kPa	250
	bar	2,5
Minimum pressure	kPa	30
	bar	0,3
Pressure loss (in 1000 l/h)	kPa	38,5
	bar	0,39

\* to the minimum useful output

<sup>(A)</sup> referred to the net calorific value at 15 °C and 1013,25 mbar: G20 = 34,02 MJ/m<sup>3</sup> - G31 = 46,34 MJ/kg

<sup>(B)</sup> referred to the gross calorific value at 15 °C and 1013,25 mbar: G20 = 37,78 MJ/m<sup>3</sup> - G31 = 50,37 MJ/kg

Gas supply pressures			
Gas		Pa	mbar
Natural G20	<b>Nom</b>	2000	20
	<b>Min</b>	1700	17
	<b>Max</b>	2500	25
Propane G31	<b>Nom</b>	3700	37
	<b>Min</b>	2500	25
	<b>Max</b>	4500	45

Gas rate maximum		
Natural G20	m <sup>3</sup> /h	2,91
Propane G31	kg/h	2,14
Gas rate minimum		
Natural G20	m <sup>3</sup> /h	0,66
Propane G31	kg/h	0,48

Electrical data		
Voltage	V~	230
Frequency	Hz	50
Nominal Power consumption	W	91
Minimum Power consumption	W	14
Stand-by Power consumption	W	3
Protection degree		IPX5D
External fuse rating	A	3
Internal fuse rating	A	N° 2 - 2 AF



# TECHNICAL INFORMATION

Flue design		
Boiler type	B23P C13 C33 C43 C53 C63 C83 C93	
Ø Coaxial	mm	60/100
Ø Twin split pipes	mm	80/80
Ø Roof	mm	60/100
Ø Roof	mm	80/125
Nominal heat flow rate <sup>(A) (E)</sup>	kW	27,5
Exhaust temperature <sup>(E)</sup>	°C	81,0
Mass flow rate <sup>(E)</sup>	kg/s	0,0123

Other specifications		
Height	mm	703
Width	mm	400
Depth	mm	295
Weight (dry)	kg	30,8
Water volume in the boiler (up to 1 bar)	l (kg)	2,5

(2437)

Flue gas figures		
Nominal heat input <sup>(A) (E)</sup>	kW	27,5
CO <sub>2</sub> content with gas G20	%	9,0 - 9,6
O <sub>2</sub> content with gas G20	%	4,1
CO content with gas G20	ppm	190,0
Exhaust temperature <sup>(E)</sup>	°C	81,0
NO <sub>x</sub> class		6
Weighted NO <sub>x</sub>	ppm	19

<sup>(E)</sup> Values refer tests with a 1 m flue working at the nominal heat input

CO <sub>2</sub> contents		
Nominal heat input <sup>(A) (E)</sup>	kW	27,5
CO <sub>2</sub> content with gas G20 (range min - max)	%	9,0 - 9,6
CO <sub>2</sub> content with gas G31 (range min - max)	%	10,2 - 10,8
Minimum heat input <sup>(A) (E)</sup>	kW	6,2
CO <sub>2</sub> content with gas G20 (range min - max)	%	8,2 - 8,8
CO <sub>2</sub> content with gas G31 (range min - max)	%	9,4 - 10,0

# TECHNICAL INFORMATION

Model(s):	<b>BASICA COND 28S</b>	<b>M275V.28 SR</b>
Condensing boiler:	Yes	
Low-temperature boiler (**):	No	
B1 boiler:	No	
Cogeneration space heater:	No	If yes, equipped with a supplementary heater: -
Combination heater:	No	

Item	Symbol	Value	Unit	Item	Symbol	Value	Unit
<b>Rated heat output</b>	$P_{rated}$	<b>27</b>	<b>kW</b>	<b>Seasonal space heating energy efficiency</b>	$\eta_s$	<b>93</b>	<b>%</b>

For boiler space heaters and boiler combination heaters: Useful heat output

At rated heat output and high-temperature regime (*)	$P_4$	27,0	kW
At 30% of rated heat output and low-temperature regime (**)	$P_1$	9,0	kW

Auxiliary electricity consumption

At full load	$el_{max}$	0,047	kW
At part load	$el_{min}$	0,014	kW
In standby mode	$P_{SB}$	0,003	kW

For boiler space heaters and boiler combination heaters: Useful efficiency

At rated heat output and high-temperature regime (*)	$\eta_4$	88,4	%
At 30% of rated heat output and low-temperature regime (**)	$\eta_1$	98,2	%

Other items

Standby heat loss	$P_{stby}$	0,110	kW
Ignition burner power consumption	$P_{ign}$	-	kW
Annual energy consumption	$Q_{HE}$	84	GJ
Sound power level, indoors	$L_{WA}$	52	dB
Emission of nitrogen oxides	$NO_x$	33	mg/kWh

For combination heaters:

<b>Declared load profile</b>				<b>Water heating energy efficiency</b>	$\eta_{wh}$		%
Daily electricity consumption	$Q_{elec}$		kWh	Daily fuel consumption	$Q_{fuel}$		kWh
Annual electricity consumption	AEC		kWh	Annual fuel consumption	AFC		GJ

Contact details

See manual cover

(\*) High-temperature regime means 60°C return temperature at heater inlet and 80°C feed temperature at heater outlet.

(\*\*) Low temperature means for condensing boilers 30°C, for low-temperature boilers 37°C and for other heaters 50°C return temperature (at heater inlet).

---

# GENERAL REQUIREMENTS

---

## 5 GENERAL REQUIREMENTS



Benchmark places responsibilities on both manufacturers and installers. The purpose is to ensure that customers are provided with the correct equipment for their needs, that it is installed, commissioned and serviced in accordance with the manufacturer's instructions by competent persons and that it meets the requirements of the appropriate Building Regulations. The Benchmark Checklist can be used to demonstrate compliance with Building Regulations and should be provided to the customer for future reference.

Installers are required to carry out installation, commissioning and servicing work in accordance with the Benchmark Code of Practice which is available from the Heating and Hotwater Industry Council who manage and promote the Scheme. Visit [www.hhic.co.uk](http://www.hhic.co.uk) for more information.

Our Company supports the Benchmark initiative. The Benchmark Checklist is located at the back of this manual and should be completed by the Installing/Commissioning Gas Safe Registered Engineer and handed over to the User for future reference by other visiting Engineers. Also included is the Service Interval Record card that should be completed by the Service Engineer following the annual service maintenance of the boiler and system.

For Ireland (IE), it is necessary to complete a "Declaration of Conformity" to indicate compliance to I.S.813.2002.

This appliance must be installed by a competent person in accordance with the Gas Safe (installation & Use) Regulations.

### 5.1 Related documents

The installation of this appliance must be in accordance with the relevant requirements of the current Gas Safe (Installation & Use) Regulations, the Local Building Regulations, the current I.E.E. Wiring Regulations, the Regulations and by-laws of the local water undertaking, and in Scotland, in accordance with the Building Standards (Scotland) Regulation. Health and safety document n° 635 "Electricity at work regs."

It should also be in accordance with the British Standard Codes of Practice:

In Ireland (IE). The installation must be carried out by a Competent Person and registered with the RGII and installed in accordance with the current edition of I.S.813.2002 "Domestic Gas Installations" the current Building Regulations and reference should be made to the current ETCI rules for electrical installations.

### 5.2 Location of appliance

The appliance may be installed in any room or internal space, although particular attention is drawn to the requirements of the current I.E.E. Wiring Regulations, and in Scotland, the electrical provisions of the Building Regulations applicable in Scotland, with respect to the installation of the appliance in a room containing a bath or shower.

For Ireland (IE), reference should be made to the current edition of I.S.813.2002 and the current ETCI rules for electrical installations.

**Where a room-sealed appliance is installed in a room containing a bath or shower, any electrical switch or appliance control, utilising mains electricity should be so situated that it cannot be touched by a person using the bath or shower.**

The location must permit the provision of an adequate flue and termination.

For unusual locations special procedures may be necessary and BS 6798 gives detailed

# GENERAL REQUIREMENTS

guidance on this aspect.

A compartment used to enclose the appliance must be designed specifically for this purpose. This appliance is not suitable for external installation.

## 5.3 Flue system

The provision for satisfactory flue termination must be made as described in BS 5440 part 1.

For Ireland (IE), refer to I.S.813.2002.

The appliance must be installed so that the flue terminal is exposed to external air.

It must not be installed so that the terminal discharges into another room or space as an outhouse or lean-to. It is important that the position of the terminal allows a free passage of air across at all times.

The terminal should be located with due regard for the damage or discoloration that might occur to building products in the vicinity.

In cold and/or humid weather water vapour may condense on leaving the flue terminal; the effect of such "steaming" must be considered.

Plumbing may easily occur at the terminal. Where possible, terminal position which could cause a nuisance should be avoided.

The minimum acceptable spacing from the terminal to obstructions and ventilation openings are specified in Fig. 5.1.

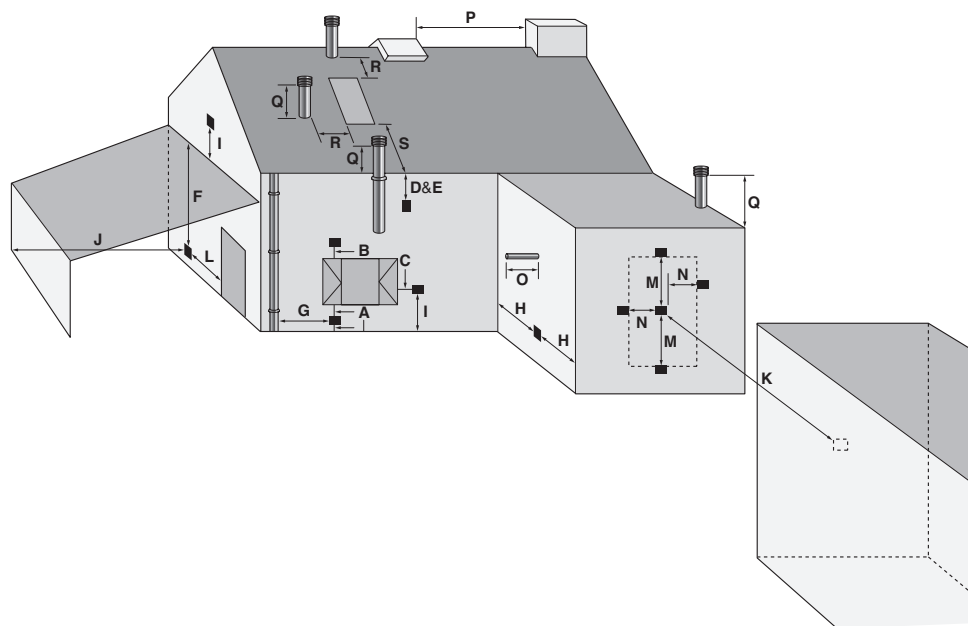

Fig. 5.1

# GENERAL REQUIREMENTS

Symbol	Location position	Minimum dimensions (mm)
A *	Directly below an opening, air brick, opening window, etc.	300
B *	Above an opening, air brick, opening window, etc.	300
C *	Horizontally to an opening, air brick, opening window, etc.	300
D **	Below temperature-sensitive building components, e.g. plastic gutter soil pipes or drain pipes	75
E **	Below eaves	200
F	Below balconies	200
G	From a vertical drain pipe or soil pipe	150
H ***	From an internal or external corner	300
I	Above ground, roof or balcony level	300
J	From a surface facing a terminal	600
K	From a terminal facing a terminal	1 200
L	From an opening in the car-port (e.g. door, window) into the dwelling	Not recommended
M	Vertically from a terminal on the same wall	1 500
N	Horizontally from a terminal on the same wall	300
O	From the wall on which the terminal is mounted	Please refer to the flue assembly instructions
P	From a vertical structure on the roof	600
Q	Above intersection with the roof	600
R	From a roof window and terminal	600
S	From a roof window and terminal	2 500

\* In addition, for temperature and structural reasons, the terminal should not be near than 150 mm to an opening in the building fabric formed for the purpose of accommodating a built-in element such as a sealed window frame.

\*\* A heat protection shield should also be installed.

\*\*\* The reference to external corners does not apply to building protrusions not exceeding 450 mm, such as disused chimneys on external walls.

## 5.4 Gas supply

The Gas meter is connected to the service pipe by the local gas region or a local gas region contractor.

If the gas supply for the boiler serves other appliances ensure that an adequate supply is available both to the boiler and the other appliance when they are in use at the same time.

Pipework must be of adequate size. Pipes of a smaller size than the boiler inlet connection should not be used.

Installation pipes should be fitted in accordance with BS 6891 and the complete installation should be tested for tightness.

For Ireland (IE), refer to I.S.813.2002.

# GENERAL REQUIREMENTS

## 5.5 Air supply

The room in which the boiler is installed does not require a purpose provided air vent.

## 5.6 Ventilation

If installed in a cupboard or compartment, it is not necessary to provide additional ventilation for cooling for this particular product. However consideration must be given to clearance requirements for maintenance (section "Precautions for installation" on page 33) and under no circumstances must stored articles be allowed to come into contact with the boiler or flue pipe.

## 5.7 Condensate drain

Ensure that the condensate discharge complies with the national or local regulations in force.

The condensate pipe must be fitted in accordance with Building Regulations.

Drain pipe material should be resistant to acid as the condensate is slightly acid with a pH less than 6.5.

The boiler includes a trap (29 on page 20) that prevents the combustion products entering the drain.

The boilers incorporate a condensate trap with a 225 mm seal to comply with BS 6798: 2008. The schematic diagrams of possible connections are given in Fig. 5.2 and Fig. 5.3.

The length of the condensate pipe should be kept to a minimum, any external pipe should not be more than 3 m in 32 mm pipe and insulated to prevent freezing.

To avoid condensate being trapped:

- the drain pipe should be run with a fall of at least 2.5° (45 mm/m) away from the boiler;
- the number of bends and joints should be kept at minimum;
- the drain pipe should be adequately fixed to prevent pipe sagging.

If a part of the drainpipe runs externally this part should be kept as short as possible and protected to reduce the risk of freezing.

### Connection of condensate drainage pipe to internal soil and vent stack.

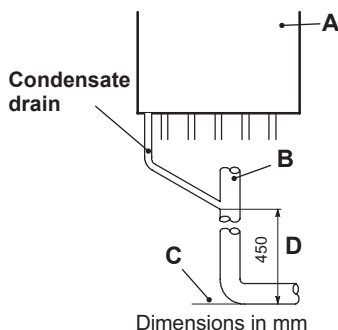

Fig. 5.2

- A Boiler
- B Internal soil and vent stack
- C Invert
- D 450 mm up to three storeys

### Connection of condensate drainage pipe downstream of a sink waste trap

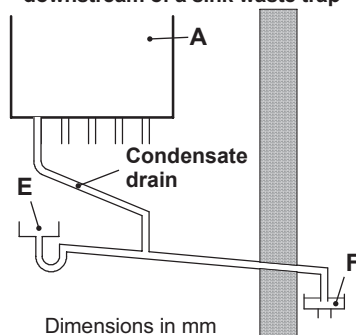

Fig. 5.3

- A Boiler
- E Sink
- F Open end of condensate drainage pipe direct into gully below grating but above water level

### Combined condensate and PRV discharge

It is possible to combine the PRV and condensate discharge pipes providing the following precautions are followed explicitly.

# GENERAL REQUIREMENTS

- A WRAS approved dry trap such as the Tesla DTUN 1522 is utilised.
- That the condensate is connected downstream of the trap as shown in the drawing and no copper pipe is utilised below this point.
- That the 32 mm equal T and subsequent downstream connection waist pipe is HT certified and capable of handling the potential short term expected temperature such as HDPE or polypropylene, consideration should also be given to the type of stack and its material in the event of the PRV activating.

At all times during design and component selection a worst case scenario event should be considered e.g. a short term exposure of high flow at high temperature along with normal running conditions of the corrosive nature of the condensate.

**Connection combined condensate and PRV discharge.**

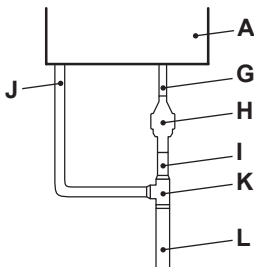

**Fig. 5.4**

- A** Boiler
- G** 15 mm copper PRV discharge pipe work
- H** WRAS approved dry trap such as the Tesla DTUN1522
- I** 22 mm copper PRV discharge pipe work
- J** 21.5 mm solvent condensate discharge pipe work
- K** High temperature rated equal 32 mm T with required adapters for condensate and PRV inlets
- L** High temperature rated Waist discharge pipe work with a minimum diameter of 32 mm

## 5.8 Water circulation (C.H.)

Detailed recommendations are given in BS 6798, BSEN 12828: 2003, BSEN 12831: 2003 & BSEN 14446: 2004; the following notes are given for general guidance. For Ireland (IE), refer to I.S.813.2002.

### Pipework

Copper tubing to BSEN 1057 is recommended for water pipes. Jointing should be either with capillary soldered or with compression fittings. Where possible pipes should have a gradient to ensure air is carried naturally to air release points and water flows naturally to drain taps. The appliance has a built-in automatic air release valve, it should be ensured as far as possible that the appliance heat exchanger is not a natural collecting point for air. Except where providing useful heat, pipes should be insulated to prevent heat loss and to avoid freezing.

Particular attention should be paid to pipes passing through ventilated spaces in roofs and under floors.

### By-pass

The appliance includes an automatic by-pass valve which protects the main heat exchanger in case of reduced or interrupted water circulation through the heating system due to the closing of thermostatic valves or isolation valves within the system.

The by-pass is calibrated to assure a minimum flow of 200-300 lts/hr through the main heat exchanger.

If you are installing a system that includes thermostatic radiator valves (TRV) and/or small bore (8-10 mm) it may be necessary to fit an external by-pass to facilitate correct operation of the boiler.

The fitting of an external bypass helps to prevent and limit system noise.

### Air release points

These must be fitted at all high points where air will natural collect and must be sited to

# GENERAL REQUIREMENTS

facilitate complete filling of the system.

## Expansion vessel

The appliance has an integral sealed expansion vessel to accommodate the increase of water volume when the system is heated.

Refer to Fig. 4.4 on page 23 for its technical data.

If the heating circuit has an unusually high water content, calculate the total expansion and add an additional sealed expansion vessel with adequate capacity.

## Mains water feed: central heating

There must be no direct connection to the mains water supply even through a non return valve, without the approval of the Local Water Authority.

## Filling

A method for initially filling the system and replacing water lost during servicing must be provided and it must comply with local water authority regulations.

The correct method is shown in Fig. 5.5.

The temporary connection must be removed immediately after filling.

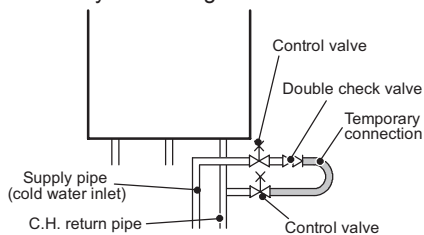

Fig. 5.5

The installer should ensure that no leaks exist either inside the boiler or on the system as frequent filling of the system could cause premature scaling of the heat exchanger.

## 5.9 Water treatment

### C.H. circuit

Where a new boiler is fitted to a new system

with either plastic or copper pipes, it is important the system is fully flushed, on completion, to ensure flux residues, swarf, oils and other installation debris is removed.

Where a new boiler is fitted to an existing system, it is important the debris from the existing system is fully removed in order to ensure the efficiency of the new appliance is maintained. Details on flushing procedure are given in the section "Initial filling of the system" on page 43 of this manual.

## 5.10 Electrical supply

### Warning, this appliance must be earthed.

External wiring to the appliance must be carried out by a competent person and be in accordance with the current I.E.E. Regulations and any local regulations which apply.

Reference should be made to the current ETCI rules for electrical installations.

For Ireland (IE), refer to I.S.813.2002.

The boiler is supplied for connection to a 230 V~ 50 Hz supply.



**The mains supply to this appliance must be protected with a 3A mains fuse, under no circumstance should this fuse rating be exceeded.**

The method of connection to the electricity supply must facilitate complete electrical isolation of the appliance by the use of a fused spur isolation switch. Its installation permits a complete switching off in the conditions of the overvoltage category III. Alternatively it can be connected with a 3A fused three pin plug and unswitched shuttered socket outlet both complying with BS 1363.

The point of connection to the electricity supply must be readily accessible and adjacent to the appliance, except where the appliance is installed in a bathroom, this must then be sited outside the bathroom.



# INSTALLATION

## 6 INSTALLATION

### 6.1 Warnings

**The use of gas appliances is subject to statutory control; it is essential to observe the current regulations and laws in force (see also chapter 5).**

**The appliance must discharge combustion products directly outside or into a suitable exhaust duct designed for this purpose. Combustion products must be discharged using original flue kits only, since they are integral parts of the boiler.**

**The appliance is not suitable for receiving condensate coming from the combustion products evacuation system.**

**Combustion air must avoid contents of chlorine, ammonia, or alkali agents. Installation of a boiler near a swimming pool, a washing machine, or a laundry does expose combustion air to these aggressive contents”.**

Before installing the boiler on an existing C.H. system, flush it out thoroughly before fitting the boiler.

This procedure is to remove the presence of any residues or impurities that could compromise good functioning of the boiler.

After flushing it is necessary to treat the system.

The conventional warranty does not cover any problems deriving from failure to comply with such provisions.

For Propane, the appliance must also conform with the requirements of the distributors and comply with current Regulations and laws in force.

The safety relief valve and the condensate drain must be connected to a suitable drain, or discharged in a safe manner.

The electrical wiring must conform with current Regulations, in particular:

- the boiler must be earthed using the correct bonding clamp.
- a fused spur isolation switch, must be installed near to the boiler that allows complete isolation in category III over voltage conditions.

Refer to section "Electric connection" on page 39 in this chapter for the electrical connections.

**Under no circumstances will the manufacturer be held responsible if the warnings and instructions contained in this manual have not been complied with.**

### 6.2 Precautions for installation

**The following prescriptions must be respected for installation:**

- The boiler must be fixed to a strong wall.
- The dimensions for the flue system (detailed in section "Choice of flue" on page 36) and the correct procedures for installing the flue, depicted in the instruction leaflet included with the flue kit, must be complied with during installation.
- To allow maintenance procedures it is necessary to leave the minimum clearances indicated in Fig. 6.1.

# INSTALLATION

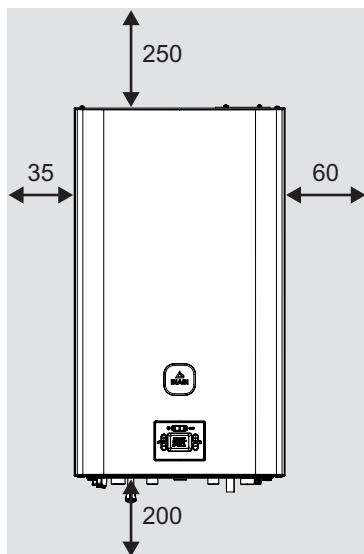

All measurements are in mm

Fig. 6.1

system chemicals are used, this will ensure that no unwanted chemical reactions take place as system chemical manufacturers ensure own brand compatibility,

## 6.3 Installing the bracket

### Precautions

Before mounting the bracket, check that the dimensions for fitting the flue system are complied with (refer to the leaflet included with the flue kit, packed separately).

Utilise the paper template supplied with the boiler to determine the fixing position for the bracket and boiler. Securely mount the bracket to the wall using appropriate fixings suitable for the type of wall construction and capable of supporting the total (wet) load. Refer to the weight given in the technical data tables specific for each model.

- When installing the boiler in a cupboard, cover or alcove allow at least 5 mm permanent clearance from the front face of the boiler. Also ensure sufficient clearance to allow free access for servicing.
- Before installing the boiler on an existing C.H. system, flush it out thoroughly before fitting the boiler, so as to remove system debris.

It is advisable to equip the system with a quality magnetic system filter, you should also use a water-treatment product in the circulating water.

The latter option in particular, has an anti-corrosive effect by promoting formation of a protective skin on metal surfaces and neutralising gases present in the water.

We recommend the use of a suitable Build-cert approved universal inhibitor to protect the C.H. system from corrosion.

Biasi UK strongly recommend that matched

# INSTALLATION

## 6.4 Overall dimensions

The boiler respects the following dimensions:

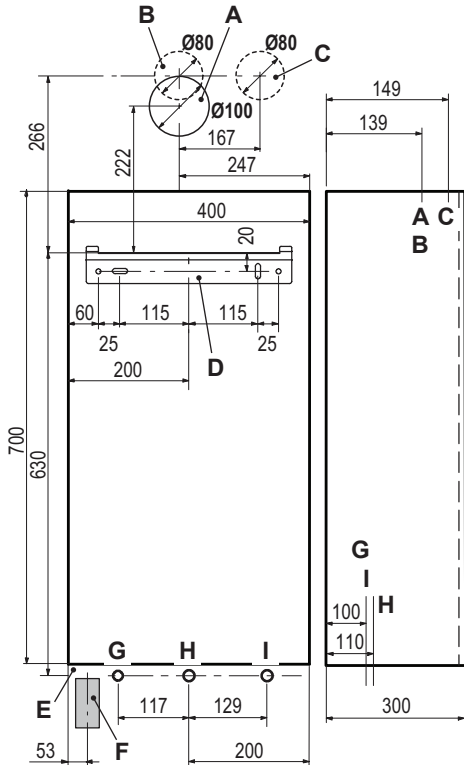

Fig. 6.2

- A Flue outlet / air intake pipe (co-axial Ø 100/60)
- B Flue outlet pipe Ø 80 mm (twin kit)
- C Air intake pipe Ø 80 mm (twin kit)
- D Bracket
- E Electric connections area
- F Condensate drain connection area
- G C.H. flow
- H Gas
- I C.H. return

## 6.5 Joints

The boiler uses the following fittings:

Functions	Pipe sizes (o.d)
Gas, C.H. return, C.H. flow	Ø 22 mm
Pressure relief valve	Ø 15 mm
Condensate drain	Ø 20 mm (rubber)

sizes in mm o.d.

Condensate drained with Ø 21.5 mm solvent weld pipe

## 6.6 Mounting the boiler

- Take the protective caps off the boiler pipework.
- Thoroughly clean the connections.
- Fix the C.H. valves "K" to position "G" and "I" (Fig. 6.2) using the ¾" gaskets.
- Fix the gas cock "L" to position "H" (Fig. 6.2), using the ¾" gasket.
- Fix the Ø 22 mm copper pipes "J" to the valves "K - L" using the ¾" gaskets.

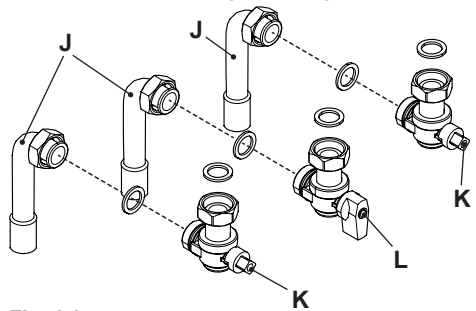

Fig. 6.3

- Connect the pipe 6 (Fig. 6.4) from the pressure relief valve to the safety discharge pipework.
- Fit the condensate drain 3 (Fig. 6.4) in to the drainage pipework.
- See also section "Condensate drain" on page 30 in this manual.

# INSTALLATION

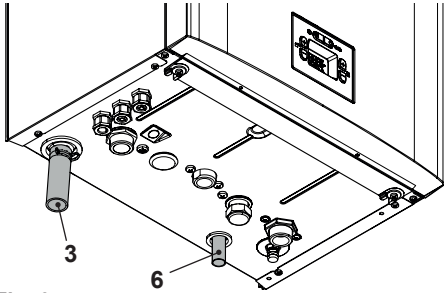

Fig. 6.4

## 6.7 Fitting the flue system

For a correct installation of the flue pipe, refer to the sheet provided together with the pre-selected kit.

The horizontal run of the flue pipes must incline about 1.5 degrees (25 mm per meter); therefore the terminal must be higher than the intake at the boiler.

The standard horizontal flue kit must be fitted horizontal as the inner flue exhaust pipe is already angled with the correct incline.

### CORRECT system for installing the wall flue

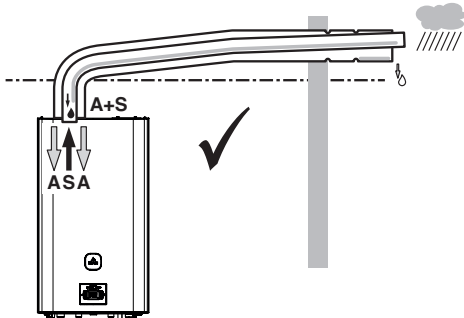

Fig. 6.5

A = air intake  
S = flue exhaust

## 6.8 Choice of flue

The flue exhaust/air intake can be installed in the mode:

C13 C33 C53 C63



**The terminal must be higher than the boiler.**

The following kits to be connected to the boiler are available:

### Wall flue exhaust kit (Fig. 6.6 A)

This kit allows the flues to be exhausted in the rear wall or at the side of the boiler.

Coaxial pipe Ø 60/100 (A)	
Nominal length	0.915 m
Minimum length	0.5 m
Maximum length	10 m

### Type C13

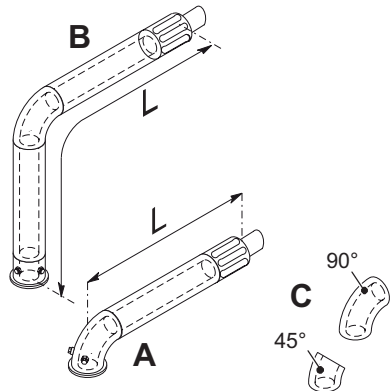

Fig. 6.6

### Vertical flue exhaust kit with 90° bend (Fig. 6.6 B)

This kit allows the boiler exhaust axis to be lifted by 635 mm.

The terminal must always exhaust horizontally.

# INSTALLATION

Coaxial pipe Ø 60/100 with 90° bend (B)	
Nominal length	1.55 m
Minimum length	0.5 m
Maximum length	10 m

## Additional bends at 45° or 90° (Fig. 6.6 C)

Coaxial bends Ø 60/100 mm.

These bends when used with the pipe reduce the maximum length of the flue pipe by:

For the bend of 45° loss	0.5 m
For the bend of 90° loss	1 m

## Exhaust intake split pipes kit Ø 80 mm - (Fig. 6.7) - (Fig. 6.8)

This kit allows the flue exhaust to be separated from the air intake.

Split pipes kit Ø 80 mm	
Minimum length	0.5 m
Maximum length (a + b)	40 m

**N.B:** The air intake and the flue outlet must not terminate on opposite sides of the building (EN 483).

### Type C<sub>13</sub>

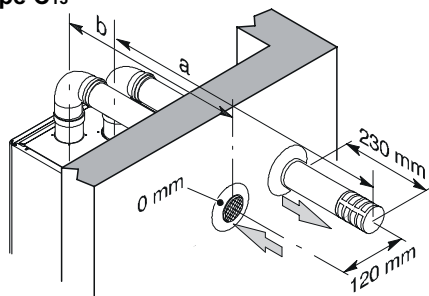

Fig. 6.7

Bends of Ø 80 mm at 90° and at 45° are available that reduce the maximum total length of the pipes by:

For the bend of 45° loss	0.9 m
For the bend of 90° loss	1.65 m

### Type C<sub>33</sub>

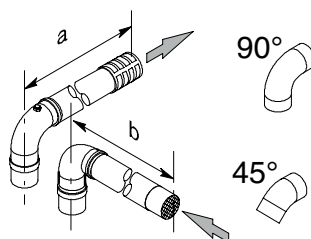

Fig. 6.8

## Roof flue exhaust kit (Fig. 6.9)

This kit exhausts directly to the roof.

Coaxial pipe	Ø 60/100 mm	Ø 80/125 mm
Nominal height	0.96 m	0.96 m
Maximum height	10 m	12 m

### Type C<sub>33</sub>

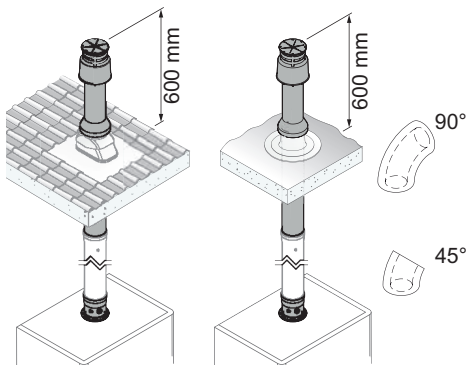

Fig. 6.9

Extensions are available for reaching the maximum height.

Bends at 90° and at 45° are available that reduce the maximum total length of the pipes by:

For the bend of 45° loss	0.5 m
For the bend of 90° loss	1 m

# INSTALLATION

## Plumbing kit A (Fig. 6.10)

Coaxial  $\varnothing$  60/100 mm + vertical part  $\varnothing$  60 mm (flue outlet).

Coaxial $\varnothing$ 60/100 mm (b) + vertical part $\varnothing$ 60 mm (a)	
Telescopic coaxial flue	0.45-0.95 m
Maximum length (a + b)	15 m

This kit allows the products of combustion to be discharged at a different location to the air intake to avoid nuisance issues.

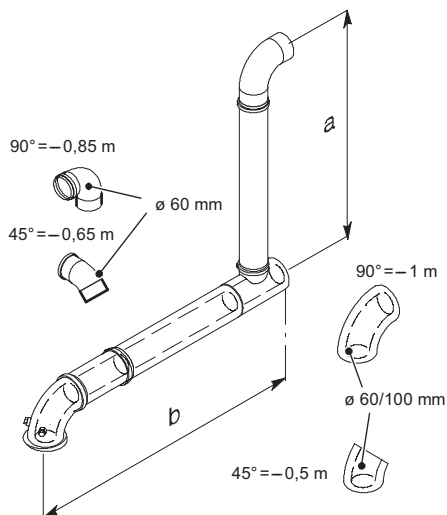

Fig. 6.10

60 mm elbows and extensions can be added to the vertical section.

Each additional elbow reduces the overall acceptable length of the flue system as follows:

For the bend of 45° (60/100 mm) loss	0.5 m
For the bend of 90° (60/100 mm) loss	1 m
For the bend of 45° (60 mm) loss	0.65 m
For the bend of 90° (60 mm) loss	0.85 m

## Plumbing kit B (Fig. 6.11) (Fig. 6.12)

Push on type  $\varnothing$  60 mm vertical plume management kit

This kit allows the products of combustion to be discharged at a different location, when used with the standard horizontal flue kit.

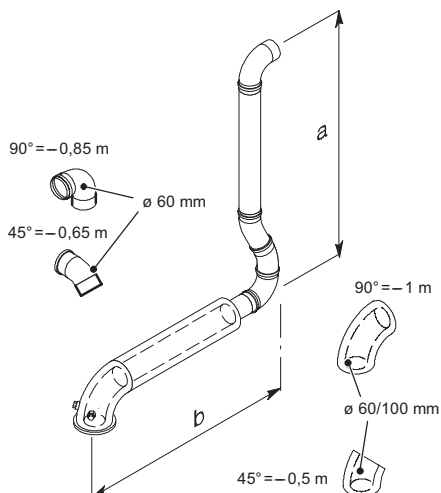

Fig. 6.11

Each additional elbow reduces the overall acceptable length of the flue system as follows:

For the bend of 45° (60/100 mm) loss	0.5 m
For the bend of 90° (60/100 mm) loss	1 m
For the bend of 45° (60 mm) loss	0.65 m
For the bend of 90° (60 mm) loss	0.85 m

The chart Fig. 6.12 gives the maximum allowed value for **a + b** of (Fig. 6.11).

# INSTALLATION

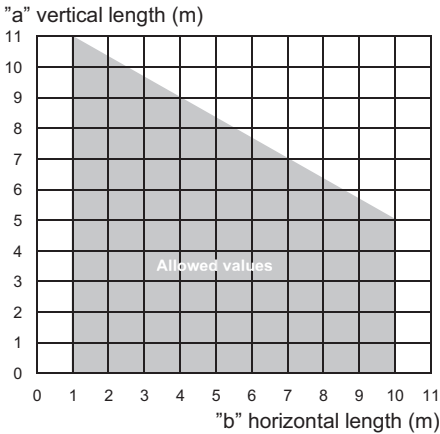

Fig. 6.12

A Plume deflector is available to assist in overcoming boundary nuisance issues.

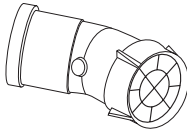

Fig. 6.13

## 6.9 Electric connection

- Unscrew screws "M" and remove the front panel "O" by pulling it and pushing it towards the top so that it is freed from the top housing Fig. 6.14 and Fig. 6.15.

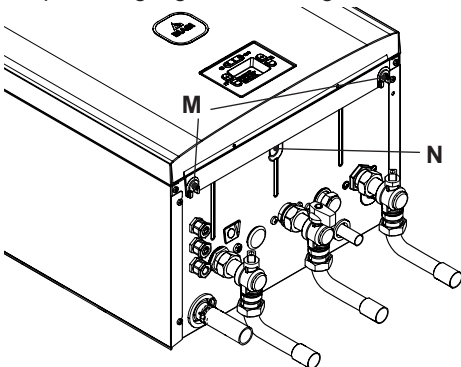

Fig. 6.14

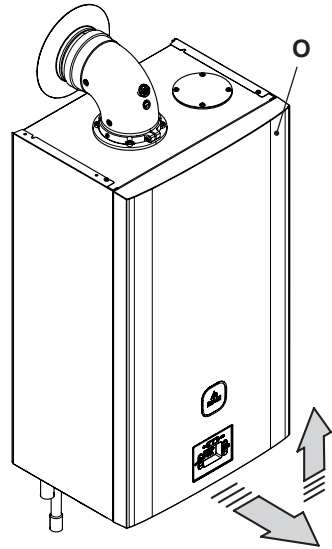

Fig. 6.15

- Unscrew the screw "N" (Fig. 6.14) and turn the control panel "P", as shown in Fig. 6.16.

To access the electric power supply, remote and external sensor terminal boards and the control board, proceed as follows:

- Unscrew the screw "Q" and lift the cover "R" to release the cables from the cable gland (Fig. 6.16).

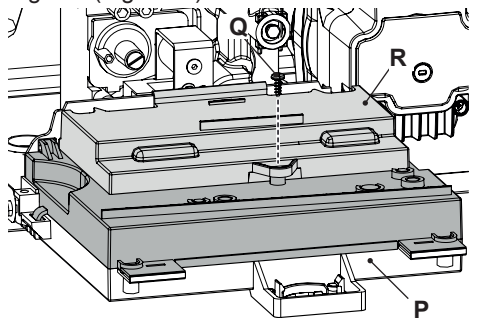

Fig. 6.16

### Electric power supply connection

- Connect the electric power supply cable coming from the fused spur isolation

# INSTALLATION

switch to the power supply terminal block of the boiler Fig. 6.17 keeping the same connections for the live (brown wire) and the neutral (blue wire). External 3A fuse or fused plug with same current rating is recommended.

- **Connect the earth cable (yellow/green) to an effective earth plant.**

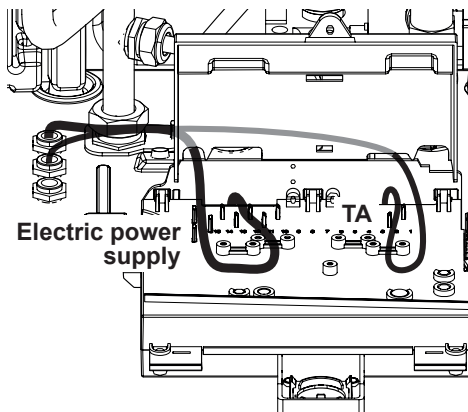

Fig. 6.17



The earth cable must be the longest of the electric power supply cables.

The appliance's electric power supply cable or wire must have a section no less than 0.75 mm<sup>2</sup>, it must be kept away from hot or sharp parts and however conform to the technical regulations in force.

## 6.10 Connecting the room thermostat or zone valves

Connect the cable for the room thermostat with a label in Fig. 6.18.



**Do not connect live wires to terminals to which the room thermostat must be connected.**

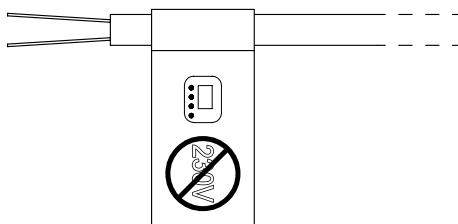

Fig. 6.18

The thermostat must be insulation class II (□) or must be correctly connected to earth.

## Connecting the zone valves controlled by the ambient thermostat

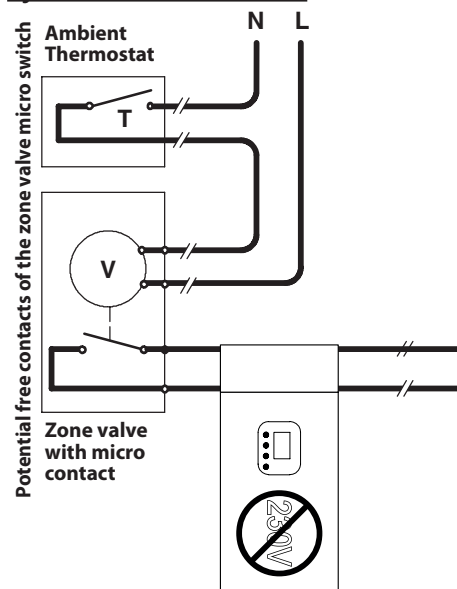

Fig. 6.19

Use the room thermostat cable indicated in Fig. 6.18 to connect the zone valve. The electric conductors on the zone valve micro contacts must be connected to the ambient thermostat cable wires as shown in Fig. 6.19.



# INSTALLATION



Do not connect live wires to terminals to which the room thermostat must be connected.

## 6.11 Installation of the external temperature probe (optional)

The external probe must be installed on the external wall of the building avoiding:

- Direct sunlight.
- Humid walls or walls subject to the formation of mildew.
- Installation near to fans, drain outlets or chimneys.
- It is recommended to be installed on a north aspect wall at least 1 m below any eaves and at least 2 m above ground.

## 6.12 Electric connection between the boiler and the external probe

To connect the external probe to the boiler use electric cables with a section no less than 0.50 mm<sup>2</sup>.

**The electric cables for connecting the external probe to the boiler must cover different channels to the voltage ones (230 V), since they are powered at a safety low voltage and their maximum length must not exceed 20 meters.**

Use the control board terminals indicated in Fig. 6.20 to connect the external sensor.

The external sensor connection wires must follow the path indicated of the ambient thermostat and come through the back of the boiler.

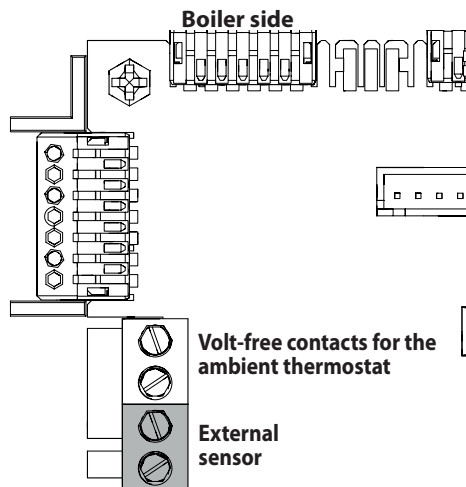

Fig. 6.20

## 6.13 Remote electric connection (optional)

Use the ambient thermostat cable marked with a label indicated in Fig. 6.18 to connect the remote.

## 6.14 Example of hydraulic systems with hydraulic separator (optional)

The hydraulic separator creates a reduced load loss zone that renders the primary circuit and secondary circuit hydraulically independent.

In this case the flow rate that passes through the circuits depends exclusively on the features of the pumps flow rate.

Therefore, by means of a hydraulic separator, the secondary circuit's flow rate is put into circulation only when the relative pump is on.

When the pump of the secondary is off, there is no circulation in the corresponding circuit and therefore, the entire flow rate pushed by the primary is by-passed through the separator.

# INSTALLATION

Thus, with the hydraulic separator, it is possible to have a constant flow rate production circuit and a variable flow rate distribution circuit.

## Hydraulic system examples

Top zone + low temperature zone.

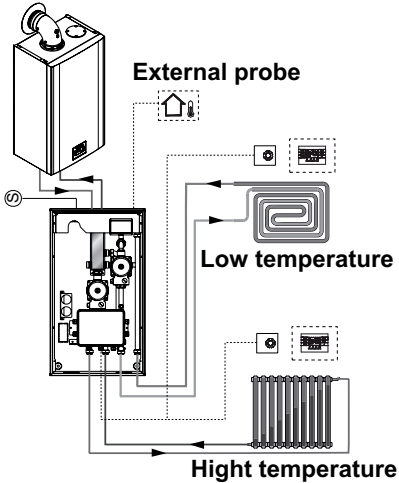

Fig. 6.21

Top zone + 2 low temperature zones.

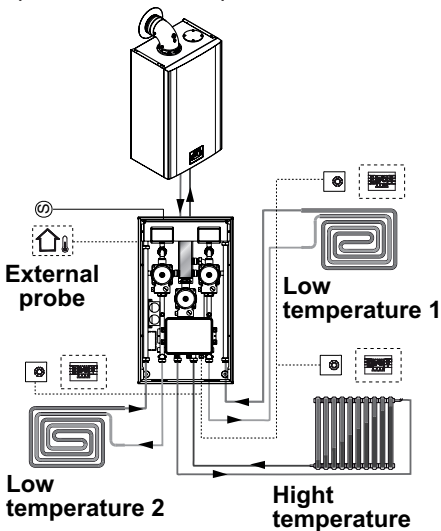

Fig. 6.22

# COMMISSIONING

## 7 COMMISSIONING

### 7.1 Warnings

The commissioning of this boiler and system must only be undertaken by a Gas Safe Registered Engineer in accordance with the requirements of the Gas Safe Installation and Use Regulations and be approved by Gas Safe.

Ensure that the Benchmark Checklist is satisfactorily completed during the commissioning process. The Checklist is located at the end of this manual. This manual should be handed to the user following completion of the installation and commissioning process. Failure to comply with these requirements may invalidate the manufacturers guarantee.

For Ireland (IE), it is necessary to complete a "Declaration of Conformity" to indicate compliance to I.S.813.2002.

### 7.2 Electrical installation

Preliminary electrical system checks to ensure electrical safety shall be carried out by a competent person. i.e. polarity, earth continuity, resistance to earth and short circuit. If a fault has occurred on the appliance the fault finding procedure should be followed as specified in the service manual.

### 7.3 Gas supply installation

- Inspect the entire installation including the gas meter, test for tightness and purge, all as described in BS 6891;  
For Ireland (IE), refer to I.S.813.2002.
- Open the gas cock 5 (Fig. 7.1) on the appliance and check the gas connector on the appliance for leaks.

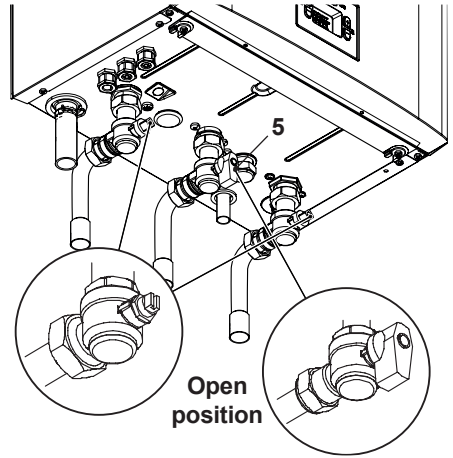

Fig. 7.1

### 7.4 Initial filling of the system

- Open the C.H. flow and return valves.
- Remove the front and side panels of the case (section "Dismantling the external panels" on page 63) and the sealed chamber lid.
- Loosen the cap on the automatic air purger valve 22 in Fig. 7.2 and leave open permanently.

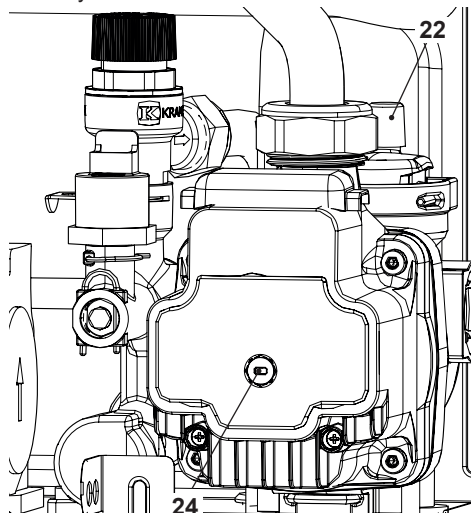

Fig. 7.2

# COMMISSIONING



- Gradually open stopcock at the filling point connection to the C.H. system until water is heard to flow; do not open fully.
- Open each radiator air vent starting at the lowest point of the system and close it only when clear water, free of bubbles, flows out.
- Purge the air from the pump by unscrewing the pump plug 24 (Fig. 7.2); release the pump shaft by turning in the direction indicated by the arrow on the information plate.
- Replace the pump plug.
- Continue filling the system. The actual reading should ideally be 1,3 bar and not less than 0,3 bar.
- Close all air release valves on the C.H. system.
- Inspect the boiler and the system for water tightness and remedy any leaks discovered.
- Cold flush the system to remove any loose particles and any system debris before starting the boiler for the first time.

proved label should be used.

- Electrically power the boiler by switching on the double pole isolation switch. The LCD display will show the message **OFF** (Fig. 7.3).



Fig. 7.3

- Press the 15 key until both  and  symbols appear on the display (Fig. 7.4).

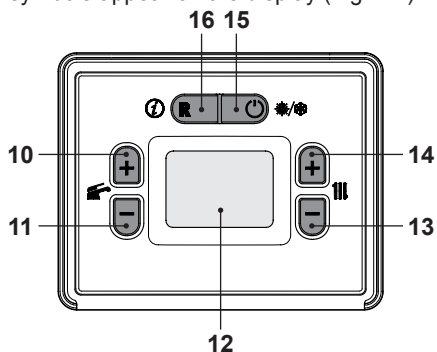

Fig. 7.4

The flushing procedure must be in line with BS7593:2006 Treatment of Water in D.H.W. & C.H. Systems.

When the installation and second filling are completed turn on the C.H. system and run it until the temperature has reached the boiler operating temperature. The system must then be immediately flushed through. This procedure must be repeated twice more.

During this operation a C.H. flushing detergent must be used in the quantities as specified by the appropriate manufacturer, whose function it is to dissolve any foreign matter which may be in the system.

## INHIBITION (Primary Heating Circuit)

On the final refilling of the heating system it is important to ensure the system water is treated with a suitable scale and corrosion inhibitor in accordance with the manufacturers instructions.

Only inhibitors that carry the Buildcert ap-



The LCD display shows the stand-by status and the  and  symbols (Fig. 7.5).



Fig. 7.5

- Make sure that the ambient thermostat is in the "heat demand" position.
- Check that the boiler with the gas cock shut-off goes into ignition lockout (E01) and, in the meantime, check the pump release.

# COMMISSIONING

- Once the pump has been released, open the gas cock and check that the boiler operates correctly both in domestic hot water and heating modes.
- Check the gas pressures and flow rates as shown in section "GAS CONVERSION" on page 60 of this booklet.
- Check that the condensate produced during functioning fills the syphon and is regularly drained in the draining pipe.
- Switch off the boiler by pressing the 15 (Fig. 7.4) key until the message **OFF** appears on the LCD display (Fig. 7.3).

## 7.5 Condensate pipe and traps

The full length of the condensate pipe should be checked for leaks.

Before running the boiler, ensure that the built in condensate trap and any other trap in the drain system is correctly filled with water.



Fill the built in condensate trap by removing the flue elbow and pouring a cupful of water into the flue outlet (Fig. 7.6).

**Warning** do not allow water to enter the outer air intake

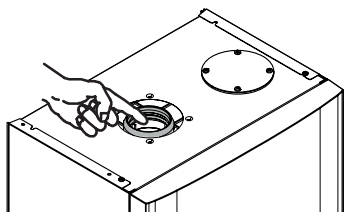

Fig. 7.6

An alternative, to the removal of the flue elbow, pour the water through the flue sampling point (Fig. 7.7).

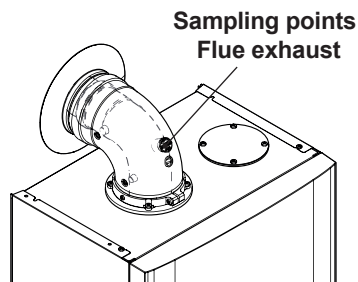

Fig. 7.7

## 7.6 Checking the gas supply pressure

This boiler has been factory tested to the highest quality control standards and set for the minimum and maximum gas working pressures, connected to a 1 m flue and a gas supply pressure of 20 mbar.

Any variation in gas supply pressure or flue length may result in the customer experiencing a harmonic noise from the boiler. In these circumstances, it may be necessary to reset the burner gas pressures in accordance with section 11 Gas Valve of the Service Manual.

It should be noted that a Flue Gas Analyser is required for this procedure.

## 7.7 Checking the inlet pressure

- Remove the boiler front panel, see section "Dismantling the external panels" on page 63.
- With the boiler switched on at full rate (maximum output power), check the supply pressure by using the 25 point in Fig. 7.8 and compare the value with that reported on the Gas supply pressure table (minimum inlet pressure) in section "Technical data BASICA COND 28S (M275V.28 SR)" on pag. 24.
- Ensure the test nipple 25 in Fig. 7.8 is firmly closed.

# COMMISSIONING

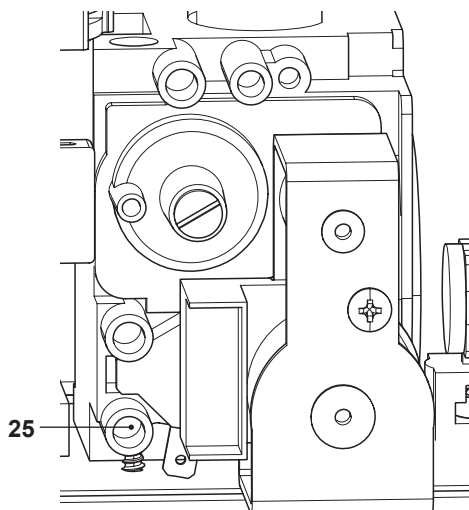

Fig. 7.8

If it does not comply with the required pressure check the gas supply line and governor for faults and/or correct adjustment.

INSTALLATION

Where the boiler is connected to a gas supply which has a zero set governor then it is necessary under the Gas Safe (Installation and Use) Regulations 26.9. to perform a combustion analysis test for CO/CO<sub>2</sub> (The limits for the boiler is given in section "Technical data BASICA COND 28S (M275V.28 SR)" on pag. 24: CO<sub>2</sub> contents / other flue gas figures) and complete the Certificate of Exemption section of the Benchmark.

**Important:** after the checks all of the test points must be sealed and tested for tightness.

## 7.8 Lighting the boiler

Some products incorporate an anti cycling time delay. It is normal when first switching the boiler on for the boiler to operate on heating for a few seconds then switch off. After 3-4 minutes has elapsed the boiler will then re ig-



nite and operate perfectly normally.

If external controls are fitted (e.g. Timeclock, room thermostat) ensure they "call for heat".

- Electrically power the boiler by switching on the double pole isolation switch. The LCD display shows the **OFF** status (only the heating antifreeze functions is active) (Fig. 7.9).



Fig. 7.9

- Press and hold the 15 key until both  and  symbols appear on the display Fig. 7.10.

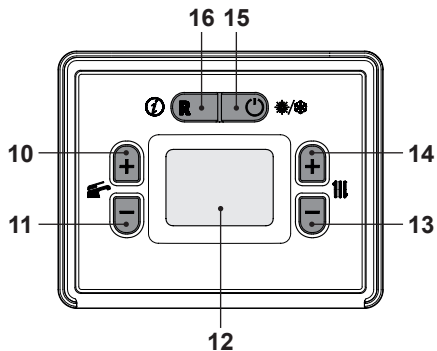

Fig. 7.10





The LCD display shows the stand-by status and the  and  symbols Fig. 7.11.



Fig. 7.11

- Open the gas cock.

# COMMISSIONING

- Make sure that the ambient thermostat is in the "heat request" position".
- Check the correct functioning of the boiler both in domestic hot water mode and in heating mode.
- Check the gas pressures and flow rates as shown in section "GAS CONVERSION" on page 60 of this booklet.
- Check that the condensate produced during operation fills the syphon and is regularly drained in the draining pipe.
- Switch off the boiler by pressing the 15 (Fig. 7.10) key for 5 seconds until the **---** symbol appears on the LCD display (Fig. 7.9).
- Press the 15 key for 5 seconds until both  and  symbols appear on the display Fig. 7.10.  
The LCD display displays the boiler temperature (primary circuit) and the  and  symbols Fig. 7.11.

The boiler will now go through an ignition sequence and the burner will light.

If after four ignition attempts (about four minutes) the boiler does not function and a code that alternates between the letter "E" and the writing **RESET** appear on the LCD display, it indicates that the safety lock-out has stopped the boiler. The display background flashes (Fig. 7.12).

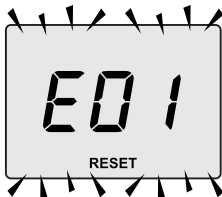

Fig. 7.12

Press the reset key on the boiler control panel 16 (Fig. 7.10) to reset its functioning.

For the first lighting up and following maintenance procedures for the gas supply, it may

be necessary to repeat the resetting operation several times so as to remove the air present in the pipework.

After five consecutive resetting attempts the reset button is inhibited. To restore its function it is necessary to switch the boiler off and on from the electrical mains, using the fused spur isolation switch fitted adjacent to the appliance.

## 7.9 Checking the ignition device

With the burner on high flame close the gas cock.

After four ignition attempts (about four minutes) the boiler does not function and a code that alternates between the letter "E" and the writing **RESET** appear on the LCD display, it indicates that the safety lock-out has stopped the boiler. The display background flashes (Fig. 7.13).

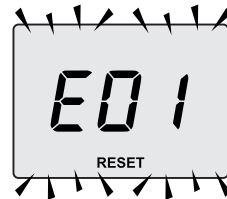

Fig. 7.13

Press the reset key 16 on the boiler control panel to reset its functioning.

## 7.10 Checking the flue system

The flue system should be visually checked for soundness. Check all clamps, gaskets and fixing are secure and tight.

Ensure that the flue terminal is sited correctly in accordance with the flue fitting instructions and Fig. 5.1 on page 28 of this manual.

To carry out a combustion check refer to the instructions given in the section "Combustion analysis check" on page 66 of this manual.

Reference figures are given in section "Tech-

---

# COMMISSIONING

---

nical data BASICA COND 28S (M275V.28 SR)" on pag. 24 (Flue gas figures).

## 7.11 Checking the condensate drain pipe

Check the soundness and integrity of the condensate drain pipe.

Verify the cleanness and correct filling of the condensate traps.

## 7.12 Instructing the user

Hand over this combined User & Installation manual and the Service manual to the end user and explain how to use the unit.

Take the User step by step through the lighting instructions.

Show the User how to switch off the appliance quickly and indicate the position of the electric supply isolator.

Explain the proper use and adjustment of all system controls; this will ensure the greatest possible fuel economy.

Explain the function and use of the function selector.

Explain and demonstrate the function of time and temperature controls (if fitted).

Explain how to turn off the appliance for both short and long periods and advise on the precautions necessary to prevent damage should the appliance be inoperative when freezing conditions may occur.

Fill in the details required on the Boiler Guarantee Certificate and hand to the User advising them to return the correct section for boiler Guarantee registration.

Finally, advise the User that, for continued safe and efficient operation, the appliance must be serviced by a competent person at least once a year.

The user is responsible for keeping the documentation integral and within reach for consultation.



# ADVANCED COMMISSIONING

## 8 ADVANCED COMMISSIONING

### 8.1 Access parameters for installer

Enter "programming mode" by holding down buttons 15 and 16 (Fig. 8.1) for 5 seconds at the same time. The code **P00** appears on the display, indicating entry into "parameter P00" (Fig. 8.2).

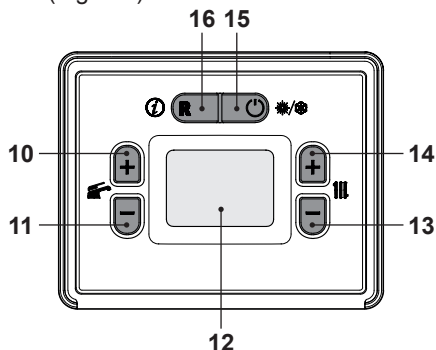

Fig. 8.1



Fig. 8.2

- Scroll through the various parameters using 10 or 11 until the LCD display shows the message **Cod**, indicating entry into "parameter Cod" (Fig. 8.3) and then displays three dashes "- - -".



Fig. 8.3

- Press the 14 button to set "**1 - -**", e such then press 10 to confirm the 1 and go to the

next segment.

- Press the 14 button to set "**1 9 -**", then press 10 to confirm the 9 and go to the next segment.
- Press the 14 button to set "**1 9 8**", then press 10 to confirm the 8 and go back to the list of parameters.
- Press button 10 or 11 to move to the desired parameter and continue configuration (see following paragraphs).

### 8.2 Enabling of operation with remote control (optional)

The boiler leaves the factory with a room thermostat enabled.

To change this setting to remote control, enter "programming mode" by following the steps described in the section "Access parameters for installer" on page 49.

- Press button 10 and hold until the LCD display shows the code **A21**, indicating entry into "parameter A21" (Fig. 8.4).



Fig. 8.4

- By using buttons 13 or 14 (Fig. 8.1) it is possible to modify the value of parameter A21 (Fig. 8.5).

**00** = Room thermostat  
**01** = Remote control

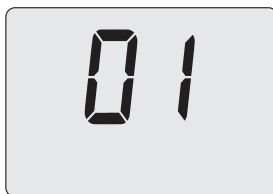

Fig. 8.5

# ADVANCED COMMISSIONING

- Press 10 or 11 (Fig. 8.1) to confirm the value entered and return to the list of parameters (Fig. 8.4).
- Press the 15 button (Fig. 8.1) to exit "programming mode".

## 8.3 Setting the K coefficient of the external temperature probe

The boiler is set with a K coefficient equal to zero for boiler functioning without the probe connected.

The K coefficients is a parameter that increases or reduces the boiler flow temperature when the outside temperature changes. When installing the external probe it is necessary to set this parameter based on the efficiency of the heating system in order to optimise the flow temperature.

If the boiler is **EQUIPED** with the remote control (optional), this parameter must be set based on the efficiency of the heating system to optimise the delivery temperature.

With heating temperature setting **25-85°C** (Fig. 8.6) (factory set) or temperature setting **25-55°C** (Fig. 8.7) or temperature setting **50-80°C** (Fig. 8.8) (see "Selecting the heating temperature set" on page 53).

In this case K setting must be done from the remote control.

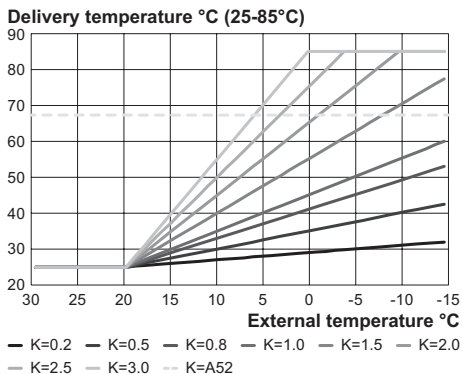

Fig. 8.6

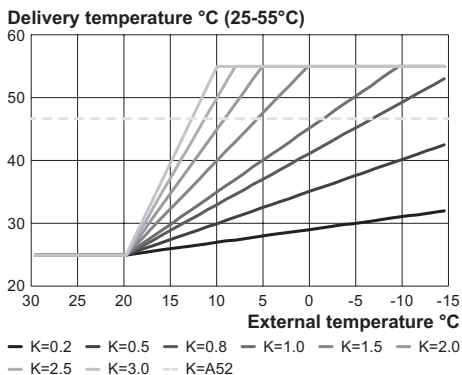

Fig. 8.7

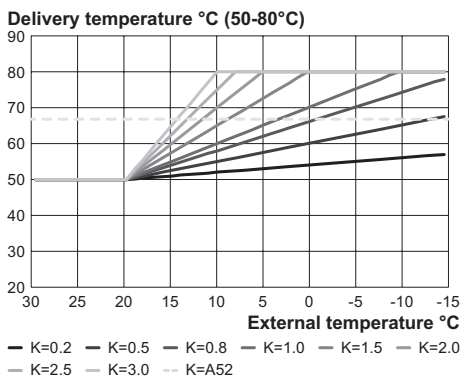

Fig. 8.8

# ADVANCED COMMISSIONING

## Sequence for setting the K coefficient

- Enter “programming mode” by pressing the 15 and 16 keys simultaneously for 5 seconds (Fig. 8.9). The code **P00** appears on the display, indicating entry into “parameter P00” (Fig. 8.10).

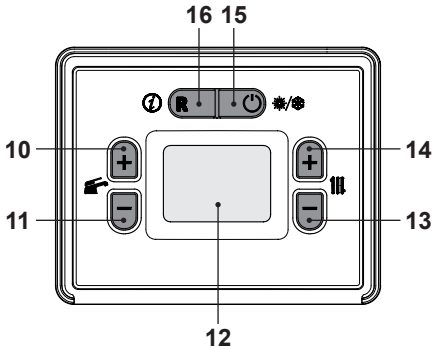

Fig. 8.9



Fig. 8.10

- Scroll through the various menus by pressing the keys 10 (back) or 11 (forward), until the LCD display shows the code **P07**, indicating entry into “parameter P07” (Fig. 8.11).



Fig. 8.11

- Press 14 (Fig. 8.9) to show the value of parameter P07 on the LCD display (Fig. 8.12).

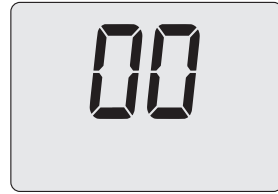

Fig. 8.12

- By using buttons 13 or 14 (Fig. 8.9) it is possible to modify the value of parameter P07:

**00** = Probe disabled (preset)  
**01** = Probe enabled (12kOhm)  
**02** = Probe enabled (10kOhm)

- Press 10 or 11 (Fig. 8.9) to confirm the value entered and return to the list of parameters Fig. 8.11.
- Press the 15 button (Fig. 8.9) to exit “programming mode”.

- Press 11 and hold until the LCD display shows the code **P08**, indicating entry into “parameter P08” (Fig. 8.13).



Fig. 8.13

- Using buttons 13 or 14 it is possible to change the value of parameter P08 from a minimum of **1.0** to a maximum of **3.0** based on the selected curve of the K coefficient in Fig. 8.7 (the value read on the display corresponds to the decimal values of the K coefficients).
- Press 10 or 11 (Fig. 8.9) to confirm the value entered and return to the list of parameters (Fig. 8.13).
- Press the 15 button (Fig. 8.9) to exit “programming mode”.

# ADVANCED COMMISSIONING

At this point the system delivery temperature will follow the trend in relation to the set K coefficient.

If the room temperature is not comfortable, you can increase or decrease the heating system delivery temperature by  $\pm 5^\circ\text{C}$  using the 13 (decrease) and 14 (increase) buttons (Fig. 8.9).

With heating temperature setting **25-85°C** (factory preset) the temperature trend for a **K 2.0** is shown in Fig. 8.14, with temperature setting of **25-55°C** the temperature trend for a **K 2.0** is shown in Fig. 8.15 while, with temperature setting of **50-80°C** the temperature trend for a **K 2.0** is shown in Fig. 8.16.

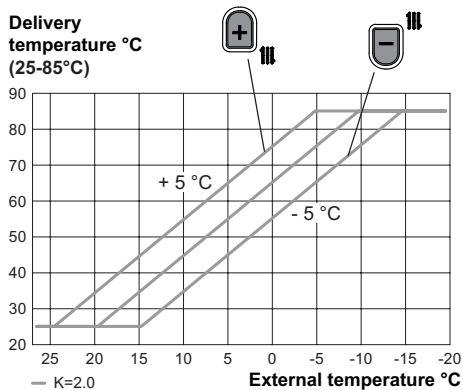

Fig. 8.14

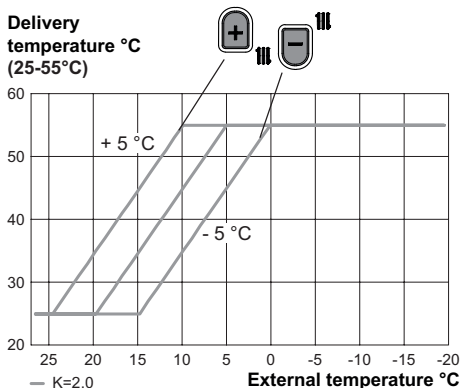

Fig. 8.15

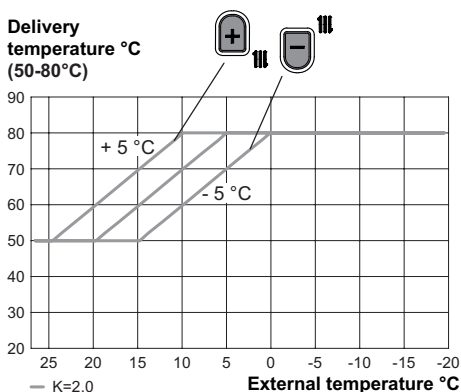

Fig. 8.16

## 8.4 Selecting the maximum heating temperature setpoint with climatic curve set

Depending on the type of high or low temperature heating system, the maximum climatic curve temperature can be set.

The boiler, in heating mode, is set for a temperature regulation a minimum of  $25^\circ\text{C}$  to a maximum of  $85^\circ\text{C}$  (factory set), a minimum of  $50^\circ\text{C}$  to a maximum of  $80^\circ\text{C}$  (high temperature) or from a minimum of  $25^\circ\text{C}$  to a maximum of  $55^\circ\text{C}$  (low temperature). Please see also "Selecting the heating temperature set" on page 53. For specific

# ADVANCED COMMISSIONING

heating system needs, once the climatic curve has been set, the maximum temperature can be lowered.

- Enter “programming mode” by following the steps described in the section "Access parameters for installer" on page 49.

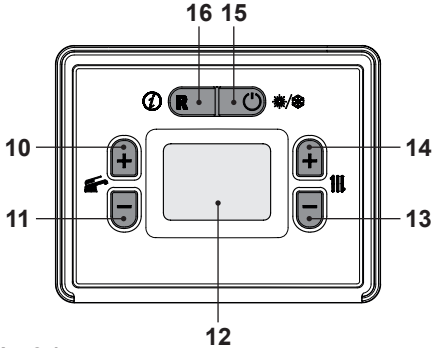

Fig. 8.17

- Press 10 and hold until the LCD display shows the code **A52**, indicating entry into “parameter A52” (Fig. 8.18).



Fig. 8.18

- By using buttons 13 or 14 (Fig. 8.17) it is possible to modify the value of parameter A52:

**85°C ÷ 25°C** = full range temperature set (factory setting)

**80°C to 50°C** = high temperature

**55°C to 25°C** = low temperature

- Press 10 or 11 (Fig. 8.17) to confirm the value entered and return to the list of parameters (Fig. 8.18).
- Press the 15 button (Fig. 8.17) to exit “programming mode”.

## 8.5 Selecting the heating temperature set

Depending on the type of high or low temperature heating system, the temperature setting range can be set.

In heating mode, the boiler is set for temperatures between 50°C and 80°C. This range can be changed to a minimum of 28°C and a maximum of 55°C.

- Enter “programming mode” by following the steps described in the section "Access parameters for installer" on page 49.

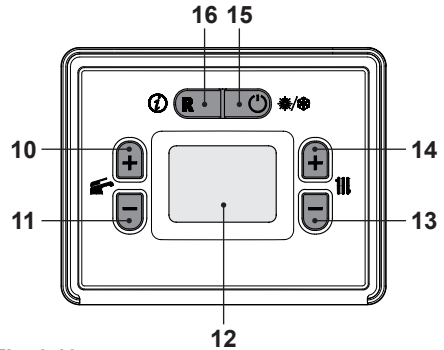

Fig. 8.19

- Press 10 and hold until the LCD display shows the code **A02**, indicating entry into “parameter A02” (Fig. 8.20).



Fig. 8.20

- By using buttons 13 or 14 (Fig. 8.19) it is possible to modify the value of parameter A02:

**01** = High temperature (50/80°C)

**02** = Low temperature (25/55°C)

**03** = Full range temperature set (25/85°C) (factory setting)

# ADVANCED COMMISSIONING

- Press 10 or 11 (Fig. 8.19) to confirm the value entered and return to the list of parameters (Fig. 8.20).
- Press the 15 button (Fig. 8.19) to exit “programming mode”.

## 8.6 Setting the pump post-circulation

The pump, in heating function, is set for a post-circulation of about one minute at the end of each heat request.

This time can be changed from a minimum of 10 seconds to a maximum of 20 minutes in programming mode, using either the control panel or the remote.

- Enter “programming mode” by pressing the 15 and 16 keys simultaneously for 5 seconds (Fig. 8.21) until the code **P00** appears on the display, indicating entry into “parameter P00” (Fig. 8.22).

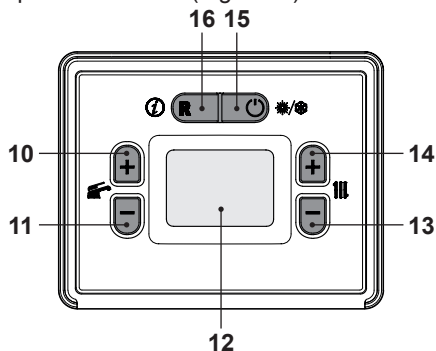

Fig. 8.21



Fig. 8.22

- Scroll through the various menus by pressing the keys 10 (back) or 11 (for-

ward), until the LCD display shows the code **P03**, indicating entry into “parameter P03” (Fig. 8.23).



Fig. 8.23

- Press the keys 14, until the value of parameter P03 on the LCD display (Fig. 8.24).

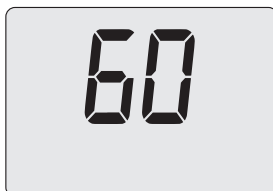

Fig. 8.24

- It is possible to modify the value of parameter **03** from **0** to **99** seconds by pressing the 13 or 14 keys.
- Press 10 or 11 (Fig. 8.21) to confirm the value entered and return to the list of parameters (Fig. 8.23).
- Press the 15 button (Fig. 8.21) to exit “programming mode”.

## 8.7 Selecting the reignition frequency

When the boiler functions in normal on/off heating mode, the minimum time between two ignitions is set at three minutes (re-ignition frequency).

This time can be changed by a minimum of 0 seconds to a maximum of 255 minutes in programming mode, using either the control panel or the remote.

- Enter “programming mode” by pressing

# ADVANCED COMMISSIONING

the 15 and 16 keys simultaneously for 5 seconds (Fig. 8.25) until the code **P00** appears on the display, indicating entry into “parameter P00” (Fig. 8.26).

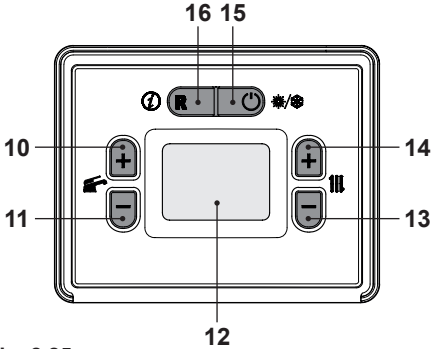

Fig. 8.25



Fig. 8.26

- Scroll through the various menus by pressing the keys 10 (back) or 11 (forward), until the LCD display shows the code **P05**, indicating entry into “parameter P05” (Fig. 8.27).



Fig. 8.27

- Press the keys 14, until the value of parameter P05 on the LCD display (Fig. 8.28).

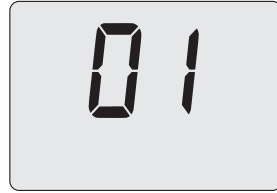

Fig. 8.28

- It is possible to modify the value of parameter **05** from **0** to **255** minutes by pressing the 13 or 14 keys.
- Press 10 or 11 (Fig. 8.21) to confirm the value entered and return to the list of parameters (Fig. 8.23).
- Press the 15 button (Fig. 8.21) to exit “programming mode”.

## 8.8 Factory reset



**The RESET returns all parameters to the factory settings.**

- Enter “programming mode” by following the steps described in the section “Access parameters for installer” on page 49.

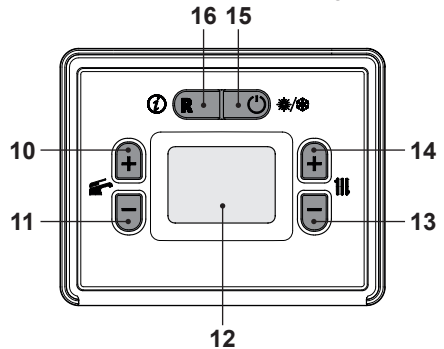

Fig. 8.29

- Press 10 and hold until the LCD display shows the code **A49**, indicating entry into “parameter A49” (Fig. 8.30).

## ADVANCED COMMISSIONING



Fig. 8.30

- By using buttons 13 or 14 (Fig. 8.29) it is possible to modify the value of parameter A49:  
**39** = factory reset
- Press 10 or 11 (Fig. 8.29) to confirm the value entered and return to the list of parameters (Fig. 8.30).
- Press the 15 (Fig. 8.29) to exit “programming mode”.

### 8.9 Settings for changing the control board

When the control board is replaced, it must be configured for the exact boiler type.

- Enter “programming mode” by holding down buttons 15 and 16 for 5 seconds at the same time (Fig. 8.31). The code **P00** appears on the display, indicating entry into “parameter P00” (Fig. 8.32).

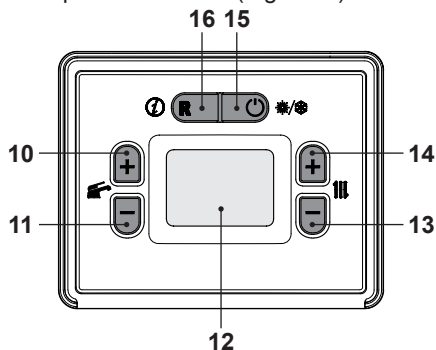

Fig. 8.31



Fig. 8.32

- Scroll through the various parameters using 10 or 11 until the LCD display shows the message **Cod**, indicating entry into “parameter Cod” (Fig. 8.33), and then displays three dashes “- - -”.



Fig. 8.33

- Press the 14 button to set “**2 - -**”, then press 10 to confirm the 2 and go to the next segment.
- Press the 14 button to set “**2 7 -**”, then press 10 to confirm the 7 and go to the next segment.
- Press the 14 button to set “**2 7 5**”, then press 10 to confirm the 5 and go back to the list of parameters.
- The code **P10** appears on the display, indicating entry into “parameter P10” (Fig. 8.34).



Fig. 8.34

- By using buttons 13 or 14 (Fig. 8.31) it is



## ADVANCED COMMISSIONING

possible to modify the value of parameter P10 (Fig. 8.35):

**05** = M275V.28 SR



Fig. 8.35

- Press 10 or 11 (Fig. 8.31) to confirm the value entered and return to the list of parameters (Fig. 8.34).
- Press the 15 button (Fig. 8.31) to exit “programming mode”.
- Enter “programming mode” by holding down buttons 15 and 16 for 5 seconds at the same time (Fig. 8.31).

- Press 10 or 11 and hold until the LCD display shows the code **P02**, indicating entry into “parameter P02” (Fig. 8.36).



Fig. 8.36

- By using buttons 13 or 14 (Fig. 8.31) it is possible to modify the value of parameter P02 (Fig. 8.37).

**78** = Default

**83** = Correct



Fig. 8.37

- Press 10 or 11 (Fig. 8.31) to confirm the value entered and return to the list of parameters (Fig. 8.36).

- Press 10 and hold until the LCD display shows the code **P09**, indicating entry into “parameter P09” (Fig. 8.38).



Fig. 8.38

- By using buttons 13 or 14 (Fig. 8.31) it is possible to modify the value of parameter P09 (Fig. 8.39).

**03** = Default

**01** = Correct

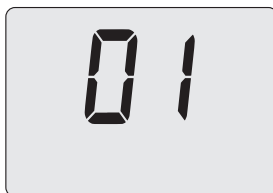

Fig. 8.39

- Press 10 or 11 (Fig. 8.31) to confirm the value entered and return to the list of parameters (Fig. 8.38).

- Press 10 and hold until the LCD display shows the code **A00**, indicating entry into “parameter A00” (Fig. 8.40).



Fig. 8.40

- By using buttons 13 or 14 (Fig. 8.31) it is possible to modify the value of parameter

## ADVANCED COMMISSIONING

A00 (Fig. 8.41).

**00** = D.H.W./C.H. (factory setting)

**01** = Storage tank

**02** = Only C.H. (correct)



Fig. 8.41

- Press 10 or 11 (Fig. 8.31) to confirm the value entered and return to the list of parameters (Fig. 8.40).
- Press 10 and hold until the LCD display shows the code **A01**, indicating entry into "parameter A01" (Fig. 8.42).



Fig. 8.42

- By using buttons 13 or 14 (Fig. 8.31) it is possible to modify the value of parameter A01 (Fig. 8.43).

**00** = Natural gas (G20)

**01** = Propane gas - LPG (G31)

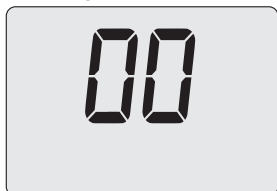

Fig. 8.43

- Press 10 or 11 (Fig. 8.31) to confirm the value entered and return to the list of parameters (Fig. 8.42).
- Press 10 and hold until the LCD display

shows the code **A02**, indicating entry into "parameter A02" (Fig. 8.44).



Fig. 8.44

- By using buttons 13 or 14 (Fig. 8.31) it is possible to modify the value of parameter A02:
  - 01** = High temperature (50/80°C)
  - 02** = Low temperature (25/55°C)
  - 03** = Full range temperature set (25/85°C) (factory setting)
- Press 10 or 11 (Fig. 8.31) to confirm the value entered and return to the list of parameters (Fig. 8.44).
- Press button 10 and hold until the LCD display shows the code **A12**, indicating entry into "parameter A12" (Fig. 8.45).

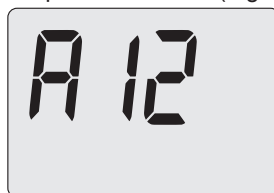

Fig. 8.45

- By using buttons 13 or 14 (Fig. 8.31) it is possible to modify the value of parameter A12 (Fig. 8.46).

**03** = Default

**04** = Correct



Fig. 8.46

## ADVANCED COMMISSIONING

- Press 10 (Fig. 8.31) to confirm the value entered and return to the list of parameters (Fig. 8.45).
- Press button 10 and hold until the LCD display shows the code **A21**, indicating entry into “parameter A21” (Fig. 8.47).



Fig. 8.47

- By using buttons 13 or 14 (Fig. 8.31) it is possible to modify the value of parameter A21 (Fig. 8.48).

**00** = Room thermostat  
**01** = Remote control

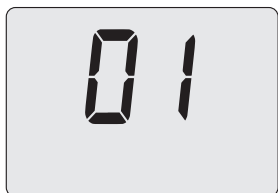

Fig. 8.48

- Press 10 (Fig. 8.31) to confirm the value entered and return to the list of parameters (Fig. 8.47).
- Press button 10 and hold until the LCD display shows the code **A38**, indicating entry into “parameter A38” (Fig. 8.49).



Fig. 8.49

- By using buttons 13 or 14 (Fig. 8.31) it is possible to modify the value of parameter

A38 (Fig. 8.50).

**60** = Default

**10** = Correct

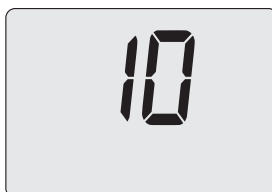

Fig. 8.50

- Press 10 (Fig. 8.31) to confirm the value entered and return to the list of parameters (Fig. 8.49).

- Press button 10 and hold until the LCD display shows the code **A50**, indicating entry into “parameter A50” (Fig. 8.51).

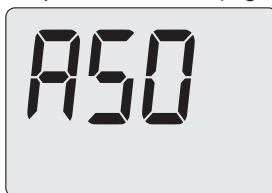

Fig. 8.51

- By using buttons 13 or 14 (Fig. 8.31) it is possible to modify the value of parameter A50 (Fig. 8.52).

**00** = Maintenance period not activated  
**01** = Maintenance period activated

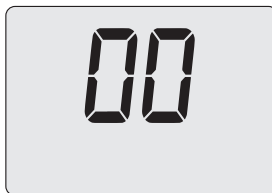

Fig. 8.52

- Press 10 (Fig. 8.31) to confirm the value entered and return to the list of parameters (Fig. 8.51).

- Press the 15 button (Fig. 8.31) to exit “programming mode”.

# GAS CONVERSION

## 9 GAS CONVERSION

### 9.1 Warnings

The commissioning of this boiler and system must only be undertaken by a Gas Safe Registered Engineer, qualified to work on Liquefied Petroleum Gas (LPG) in accordance with the requirements of the Gas Safe Installation and Use Regulations.

Components used to adapt it to the type of gas available must be genuine parts only.

Factory setting = Natural gas.

### 9.2 Operations and gas setting



Check that the gas cock mounted on the gas piping to the boiler is closed and that the appliance is not powered.

- Remove the body's front panel and turn the control panel as shown in section "MAINTENANCE" on page 62.
- Unscrew the connector "B" and remove the pipe "A" (Fig. 9.1).

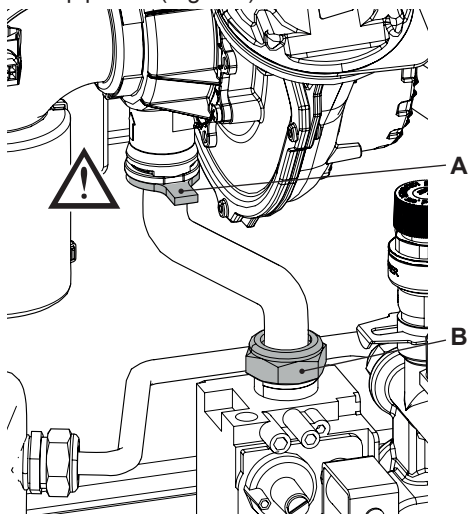

Fig. 9.1

- Carry out gas conversion by correctly replacing the gas restrictor (Fig. 9.2), referring to section "Technical data BASICA COND 28S (M275V.28 SR)" on page 24.

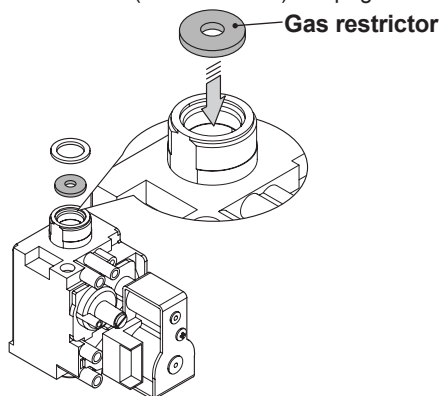

Fig. 9.2



Attention, to reassemble repeat the operations carried out in reverse order. Be careful not to damage the OR gasket of the gas pipe when inserting the pipe in the air/gas mixer. After any service operation on the components of the gas circuit check all the connections for gas tightness.

The factory boiler is set for functioning with Natural gas (G20).

To set the functioning of the boiler with LPG (G31) gas, carry out the following settings:

- Enter "programming mode" by following the steps described in the section "Access parameters for installer" on page 49.

## GAS CONVERSION

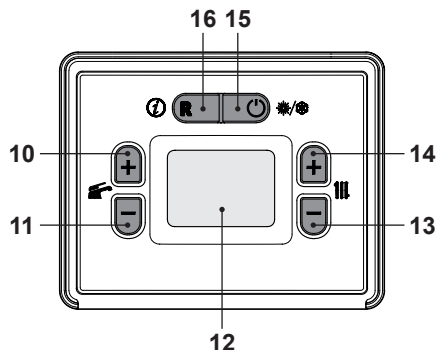

Fig. 9.3

- The code **A01** appears on the display, indicating entry into "parameter A01" (Fig. 9.4).



Fig. 9.4

- By using buttons 13 or 14 (Fig. 9.3) it is possible to modify the value of parameter A01 (Fig. 9.5).

**00** = Natural gas (G20)

**01** = Propane gas - LPG (G31)

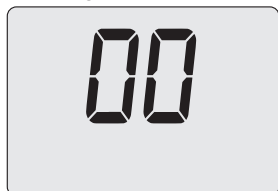

Fig. 9.5

- Press 10 or 11 (Fig. 9.3) to confirm the value entered and return to the list of parameters (Fig. 9.4).
- Press the 15 button (Fig. 9.3) to exit "programming mode".
- Calibrate the gas valve according to the

instructions given in the Service manual, section Gas valve - Adjustment.

- Reposition the control panel and reassemble the front panel of the body.
- Apply the label indicating the type of gas and the pressure value for which the unit is set. The self-adhesive label is contained in the documentation envelope attached to the boiler.



**"Warning if during any PCB re programming you disengage the power supply to the boiler you may corrupt the software setup, ensure you wait at least 10 seconds after any re programming before any power isolation event takes place".**

## 10 MAINTENANCE

### 10.1 Warnings

The procedures detailed in this chapter **must be carried out only by a Gas Safe Registered Engineer**. Thus you are advised to contact an Authorised Service Agent.

**For Ireland (IE), the servicing work must be carried out by a competent RGII registered Person.**

For efficient and continuous operation of the boiler you are advised to have, at least once a year, maintenance and cleaning done by an Approved Service Engineer.

**Isolate the appliance from the electricity supply** by turning off the fused spur isolation switch adjacent to the appliance.

**Turn off the gas cock**, before carrying out any procedures, whatsoever, for cleaning, maintenance, opening or dismantling boiler panels.



**Other devices i.e. external controls may lead dangerous voltage inside the appliance as well. Ensure they are isolated. In case of doubt turn off the general system switch.**

The Engineer should complete the Service Interval Record at the back of the manual.

### 10.2 Programming the maintenance period

- Enter "programming mode" by following the steps described in the section "Access parameters for installer" on page 49.

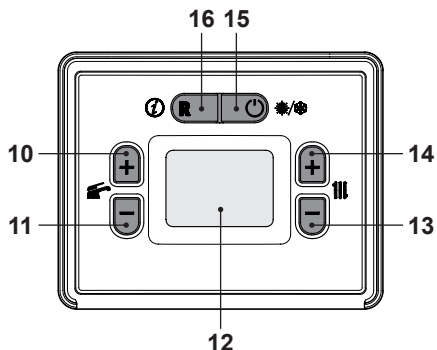

Fig. 10.1

- Press 10 and hold until the LCD display shows the code **A51**, indicating entry into "parameter A51" (Fig. 10.2).

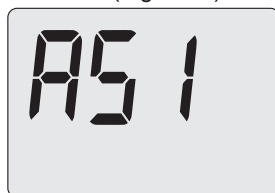

Fig. 10.2

- By using buttons 13 or 14 (Fig. 10.1) it is possible to modify the value of parameter A51 from 1 to 52 weeks (52 = 1 year).
- Press 10 or 11 (Fig. 10.1) to confirm the value entered and return to the list of parameters (Fig. 10.2).
- Press 11 and hold until the LCD display shows the code **A50**, indicating entry into "parameter A50" (Fig. 10.3).



Fig. 10.3

- By using buttons 13 or 14 (Fig. 10.1) it is

# MAINTENANCE

possible to modify the value of parameter A50:

- 00 = Maintenance period not activated
- 01 = Maintenance period activated

- Press 10 or 11 (Fig. 10.1) to confirm the value entered and return to the list of parameters (Fig. 10.3).
- Press the 15 button (Fig. 10.1) to exit "programming mode".

## 10.3 Dismantling the external panels

### Front panel

- Unscrew screws "A" and remove the front panel "E" by pulling it and pushing it towards the top so that it is freed from the top housings (Fig. 10.4 and Fig. 10.5).

### Side panels

Loosen screws "B - G" and "C - I" in Fig. 10.4 and remove the two side panels "F" and "H" by pulling towards the outside.

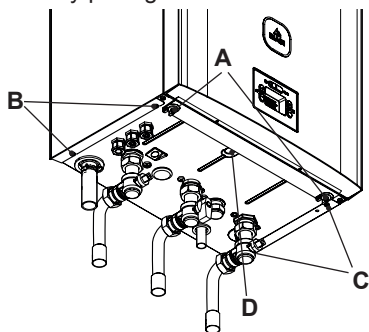

Fig. 10.4

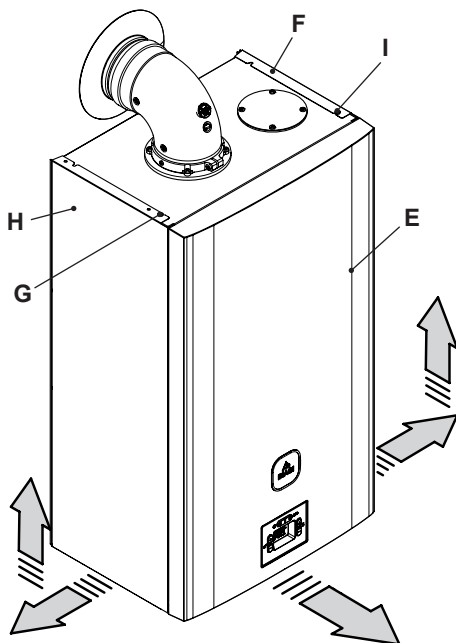

Fig. 10.5

### Control panel

Remove screws "D" (Fig. 10.4) and turn the controls panel "J", as shown in figure Fig. 10.6, to access in an optimal manner the components inside the boiler.

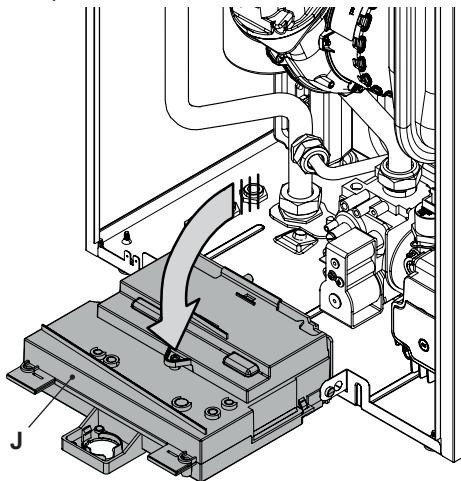

Fig. 10.6

# MAINTENANCE

## 10.4 Reassembly the external panels

### Side panels

Fit the external panels "F" and "H" in the reverse order to that described on section "Dismantling the external panels" on page 63.

### Front panel

- Fit the front panel "E" in the reverse order to that described on section "Dismantling the external panels" on page 63.

## 10.5 Emptying the C.H. system

- Close the C.H. isolating valves (4 and 8 in Fig. 10.7).

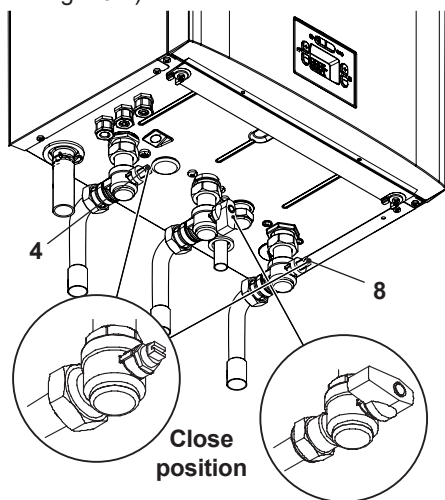

Fig. 10.7

- Loosen the central heating drain cock 7 indicated in Fig. 10.8.

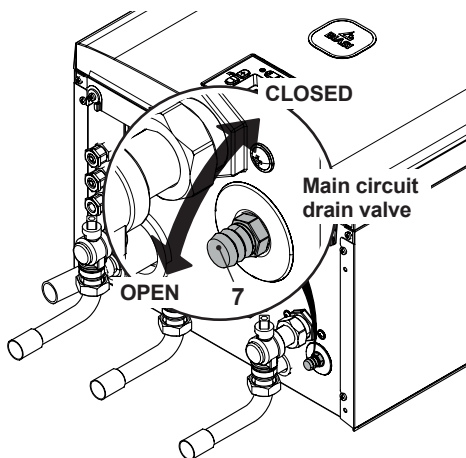

Fig. 10.8

- To make draining easier, lift the plug 22 of the automatic relief valve in Fig. 10.9.

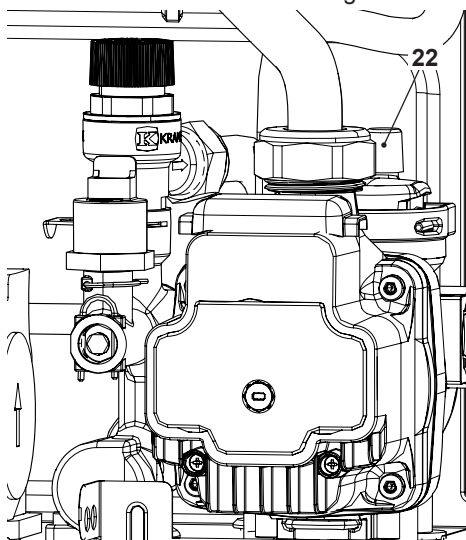

Fig. 10.9

## 10.6 Cleaning the condensing primary exchanger and the burner

Removing the fan burner unit 33 in Fig. 10.10.



# MAINTENANCE

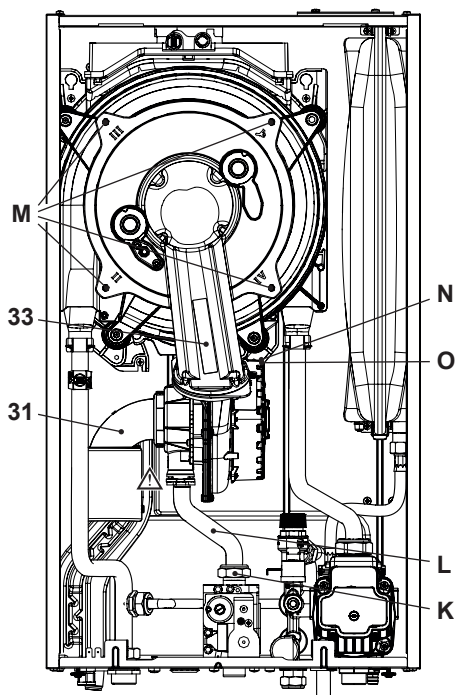

Fig. 10.10

- Remove the front panel and lower the controls panel (see "Dismantling the external panels" on page 63).
- Disconnect the wiring of the ignition and detection electrodes.
- Unscrew the connector "K" and remove the pipe "L".
- Disconnect the fan connector "N" by pulling it (Fig. 10.10 - Fig. 10.11).
- Disconnect the fan connector "O" by pressing the plastic hook positioned at the bottom part of the connector (Fig. 10.10 - Fig. 10.11).

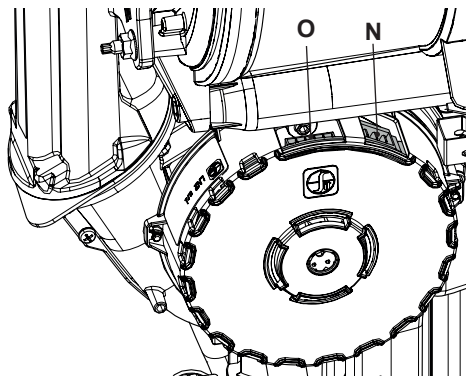

Fig. 10.11

- Unscrew screws "M" and remove the fan burner unit 33 (Fig. 10.10).
- Extract the burner casing by pulling it outwards.
- The silicon seal on the front wall of the combustion chamber Fig. 10.12 must be replaced if worn.

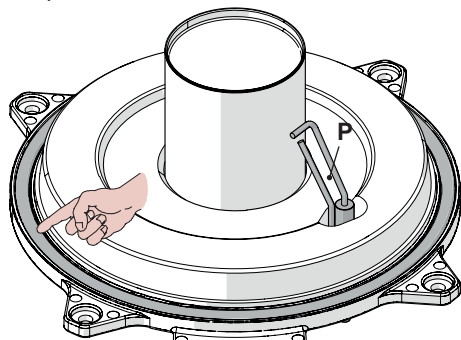

Fig. 10.12

- The ignition/detection electrode "P" in Fig. 10.12 also functions as a sensor for the correct drainage of the condensate. Should the mentioned electrode come into contact with the condensate water present within the combustion chamber it sends the boiler into safety lockout. Therefore, should the insulation be wet or deteriorated, provide for the substitution of the same.

# MAINTENANCE

## Electrodes disclaimer.

**Note to service engineers:** It is required that the burner seal, lip seal and mixing chamber seal along with the flame detection electrode are inspected every year and replaced every 24 months. Failure to inspect the flame detection probe, seals and replace as required may render the guarantee void.

**Caution:** After any periodical servicing or disturbance the combustion chamber silicon seal Fig. 10.12 must be fully inspected and replaced at the discretion of the service engineer.

After any disturbance to the chamber door seal the appliance must undergo a full analytical combustion performance check.

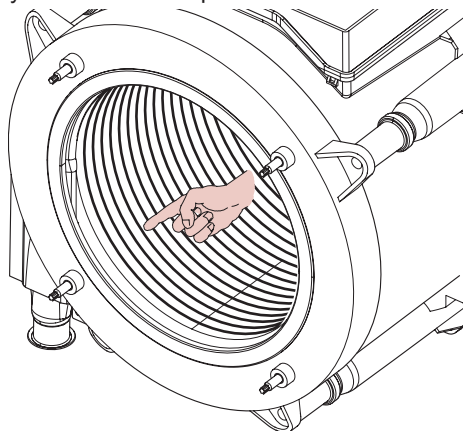

Fig. 10.13

If the condensate primary exchanger elements are dirty (notable only after removing the burner body), brush them using a bristle brush and remove the dirt using a suction device.

The burner does not require any particular maintenance, just remove dust using a bristle brush.

More specific maintenance will be valued and carried out by a competent Gas Safe Registered Engineer.

**Attention,** to reassemble repeat the operations carried out in reverse order. Be careful not to damage the OR gasket of the gas pipe when inserting the pipe in Air box.

**After any service operation on the components of the gas circuit check all the connections for gas leaks.**

## 10.7 Check the pressure of the heating expansion vessel

Drain the heating circuit as described in section "Emptying the C.H. system" on page 64 and check that the expansion vessel pressure is not less than 1 bar. If the pressure is less, see to correct pressurisation.

## 10.8 Checking the flue system

Have the integrity of the flue outlet and air intake pipe, checked periodically, at least once a year. For all the above maintenance operations it is advisable to call an approved Service Engineer.

## 10.9 Combustion analysis check

It is compulsory to conduct a combustion analysis. Remove the plug as indicated in Fig. 10.14 and carry out combustion analysis check and adjustment if necessary as described in the section "Gas valve - Adjustment - Chimney Sweep Mode" of the Service manual.

# MAINTENANCE

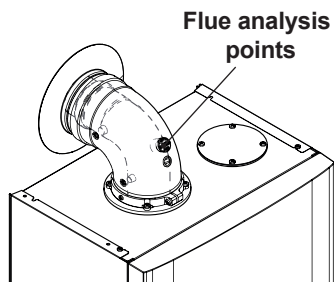

Fig. 10.14

- Make sure that the ambient thermostat is in the position “call for heat”.
- Activate the “flue sweep function” at maximum heating power (see “Setting the boiler flue sweep function” on page 68).
- Check the combustion of the boiler using the outlets located on the flue tubes (Fig. 10.14) and compare the data measured with that following.

Model BASICA COND 28S - M275V.28 SR		
Nominal heat input <sup>(A) (E)</sup>	kW	21,0
Nominal efficiency	%	98,2
Combustion efficiency	%	98,4
Air index	n	1,2
Flue gas CO <sub>2</sub> content	%	9,0 - 9,6
Flue gas O <sub>2</sub> content	%	4,1
Flue gas CO content	ppm	140
Flue gas temperature	°C	82,0

Values refer to tests with a an 80 mm double exhaust split by 1 + 1 m and natural gas G20 and a supply / return heating temperature of 60°/80°C.

Fig. 10.15

The values in the tables are measured at the nominal useful power with factory calibration.

## 10.10 Checking the condensate drain pipe

The condensate drain pipe 29 (Fig. 10.16) does not require any particular maintenance but just check:

- That no solid deposits have formed, if so remove them.
- That the condensate drain piping is not clogged.

To clean the inside of the siphon, remove it and turn it upside down to remove any dirt.

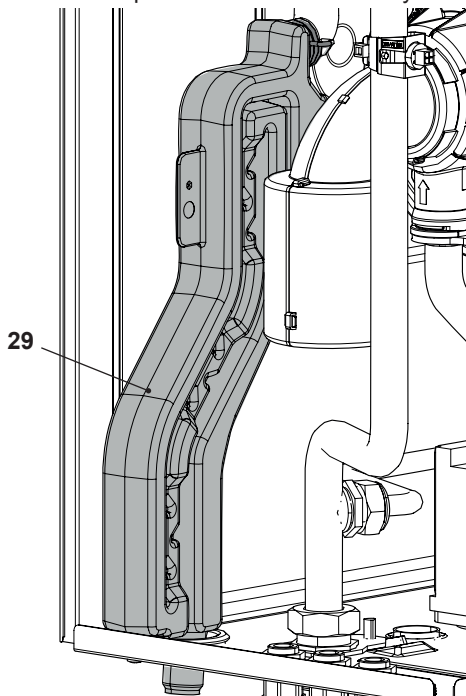

Fig. 10.16

## 10.11 Visual inspection of appliance

Visually inspect all water joints, seals and connections for any evidence of leakage and retighten, grease or replace them as necessary.

## 10.12 Checking the gas supply pressure

Check appliance for gas tightness. Re-check operational pressures as described in section “Checking the gas supply

# MAINTENANCE

pressure" on page 45 of this manual.

## 10.13 Water inhibitor concentration

Where chemical products are used the level of water treatment should be checked on an annual basis and re treated after full or partial drain down.

A conductivity meter can be used to check the correct concentration of inhibitor in the heating water.

## 10.14 Setting the boiler flue sweep function

With the boiler set in flue sweep mode, it is possible to exclude some boiler automatic functions making check and control operations easier.

- Enter "programming mode" by pressing the 15 and 16 keys simultaneously for 5 seconds (Fig. 10.17) until the code **P00** appears on the display, indicating entry into "parameter P00" (Fig. 10.18).

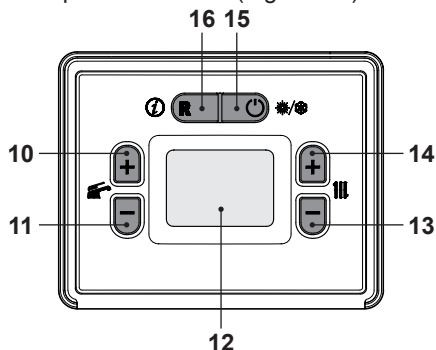

Fig. 10.17



Fig. 10.18

## Flue sweep function at minimum output in domestic hot water mode

- Scroll through the various menus by pressing the keys 10 (back) or 11 (forward), until the LCD display shows the code **P06**, indicating entry into "parameter P06" (Fig. 10.19).



Fig. 10.19

- Press the 14 key to show the value of parameter P06 on the LCD display (Fig. 10.20).



Fig. 10.20

- Press the 14 key and the LCD display shows the number **01**, indicating activation of the "chimney sweep function" at minimum output (Fig. 10.21).
- Press the 10 key (Fig. 10.17) to confirm the value entered and activate the function.

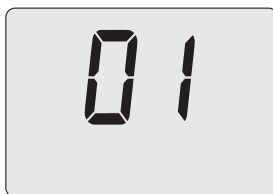

Fig. 10.21

## Flue sweep function at maximum output in domestic hot water mode

- Press the 14 key and the LCD display shows the number **01**, indicating activa-

tion of the “chimney sweep function” at minimum output in domestic hot water mode.

- Press the 10 key (Fig. 10.17) to confirm the value entered and activate the function (Fig. 10.22).



Fig. 10.22

### **Flue sweep function at maximum output in heating mode**

- Press the 14 key and the LCD display shows the number **03**, indicating activation of the “chimney sweep function” at maximum output in heating mode.
- Press the 10 key (Fig. 10.17) to confirm the value entered and activate the function (Fig. 10.23).



Fig. 10.23

### **Exiting the chimney sweep function**

- To exit the chimney sweep, reset the value of parameter **P06** to **00** or wait 15 minutes with the boiler switched off (**OFF**).
- Switch off the boiler by pressing button 15 (Fig. 10.17) until the letters **OFF** appear on the LCD display (Fig. 10.24).



Fig. 10.24

# Benchmark Commissioning & Warranty Validation Service Record

It is a requirement that the boiler is installed and commissioned to the manufacturers' instructions and the data fields on the commissioning checklist completed in full.

To instigate the boiler warranty the boiler needs to be registered with the manufacturer within one month of the installation. The warranty rests with the end-user (consumer), and they should be made aware it is ultimately their responsibility to register with the manufacturer, within the allotted time period.

It is essential that the boiler is serviced in line with the manufacturers' recommendations, at least annually. This must be carried out by a competent Gas Safe registered engineer. The service details should be recorded on the Benchmark Service and Interim Boiler Work Record and left with the householder. Failure to comply with the manufacturers' servicing instructions and requirements will invalidate the warranty.



[www.hhic.co.uk](http://www.hhic.co.uk)

**This Commissioning Checklist is to be completed in full by the competent person who commissioned the boiler as a means of demonstrating compliance with the appropriate Building Regulations and then handed to the customer to keep for future reference.**

Failure to install and commission according to the manufacturers' instructions and complete this Benchmark Commissioning Checklist will invalidate the warranty. This does not affect the customer's statutory rights.

\* All installations in England and Wales must be notified to Local Authority Building Control (LABC) either directly or through a Competent Persons Scheme. A Building Regulations Compliance Certificate will then be issued to the customer.

© Heating and Hotwater Industry Council (HHIC)



[www.centralheating.co.uk](http://www.centralheating.co.uk)

# GAS BOILER SYSTEM COMMISSIONING CHECKLIST & WARRANTY VALIDATION RECORD

Address:													
Boiler make and model:													
Boiler serial number:													
Commissioned by (PRINT NAME):						Gas Safe registration number:							
Company name:						Telephone number:							
Company email:						Company address:							
										Commissioning date:			
Heating and hot water system complies with the appropriate Building Regulations?											Yes		
Optional: Building Regulations Notification Number (if applicable):													
Time, temperature control and boiler interlock provided for central heating and hot water											Yes		
Boiler Plus requirements (tick the appropriate box(s))													
Boiler Plus option chosen for combination boiler in ENGLAND						Weather compensation			Smart thermostat with automation and optimisation				
						Load compensation			Flue Gas Heat Recovery				
Time and temperature control to hot water			Cylinder thermostat and programmer/timer						Combination boiler				
Zone valves		pre-existing		Fitted		Not required							
Thermostatic radiator valves		pre-existing		Fitted		Not required							
Automatic bypass to system		pre-existing		Fitted		Not required							
Underfloor heating		pre-existing		Fitted		Not required							
Water quality													
The system has been flushed, cleaned and a suitable inhibitor applied upon final fill, in accordance with BS7593 and boiler manufacturers' instructions											Yes		
What system cleaner was used?						Brand:			Product:				
What inhibitor was used?						Brand:			Product:				
Primary water system filter		pre-existing		Fitted		Not required							
CENTRAL HEATING MODE measure and record (as appropriate)													
Gas rate (for combination boilers complete DHW mode gas rate)						m <sup>3</sup> /hr			or			ft <sup>3</sup> /hr	
Central heating output left at factory settings?						Yes			No				
If no, what is the maximum central heating output selected?												kW	
Dynamic gas inlet pressure												mbar	
Central heating flow temperature												°C	
Central heating return temperature												°C	
System correctly balanced/rebalanced?												Yes	
COMBINATION BOILERS ONLY													
Is the installation in a hard water area (above 200ppm)?						Yes			No				
Water scale reducer/softener		pre-existing		Fitted		Not required							
What type of scale reducer/softener has been fitted?						Brand:			Product:				
Water meter fitted?						Yes			No				
If yes- DHW expansion vessel		pre-existing		Fitted		Not required							
Pressure reducing valve		pre-existing		Fitted		Not required							
DOMESTIC HOT WATER MODE Measure and record													
Gas rate						m <sup>3</sup> /hr			or			ft <sup>3</sup> /hr	
Dynamic gas inlet pressure at maximum rate												mbar	
Cold water inlet temperature												°C	
Hot water has been checked at all outlets						Yes			Temperature			°C	
CONDENSATE DISPOSAL													
The condensate drain has been installed in accordance with the manufacturers' instructions and/or BS5546/BS6798											Yes		
Point of termination						Internal			External (only where internal termination impractical)				
Method of disposal						Gravity			Pumped				
ALL INSTALLATIONS													
Record the following		At max rate:		CO ppm		CO <sub>2</sub> %		CO/CO <sub>2</sub>		Ratio			
		At min rate (where possible)		CO ppm		CO <sub>2</sub> %		CO/CO <sub>2</sub>		Ratio			
Where possible, has a flue integrity check been undertaken in accordance with manufacturers' instructions, and readings are correct?											Yes		
The operation of the boiler and system controls have been demonstrated to and understood by the customer											Yes		
The manufacturers' literature, including Benchmark Checklist and Service Record, has been explained and left with the customer											Yes		
Commissioning Engineer's signature													
Customer's signature (To confirm satisfactory demonstration and receipt of manufacturers' literature)													

\* All installations in England and Wales must be notified to Local Authority Building Control (LABC) either directly or through a Competent Persons Scheme. A Building Regulations Compliance Certificate will then be issued to the customer.



# SERVICE & INTERIM BOILER WORK RECORD

It is recommended that your boiler and heating system are regularly serviced and maintained, in line with manufacturers' instructions, and that the appropriate service / interim work record is completed.

## Service provider

When completing a service record (as below), please ensure you have carried out the service as described in the manufacturers' instructions. Always use the manufacturers' specified spare parts.

<b>SERVICE/INTERIM WORK ON BOILER</b> <small>delete as appropriate</small>				Date:		
Engineer name:		Company name:				
Telephone N°:		Gas Safe registration N°:				
Max rate	CO	ppm	CO <sub>2</sub>	%	CO/CO <sub>2</sub>	
Min rate	CO	ppm	CO <sub>2</sub>	%	CO/CO <sub>2</sub>	
Where possible, has a flue integrity check been undertaken in accordance with manufacturers' instructions, and readings are correct?					yes	
Gas rate:	m <sup>3</sup> /h	OR	ft <sup>3</sup> /h			
Electrode changed? <small>delete as appropriate</small>	Yes	No				
Parts fitted:						
System inhibitor concentration has been checked and appropriate action taken, in accordance with BS 7593 and boiler manufacturers' instructions. *					yes	n/a
Comments:						
Signature:						

\*A System inhibitor efficacy test is required on every annual service in accordance with the manufacturers' instructions and BS 7593. It is only acceptable to not have undertaken this if the service engineers attendance visit was in between annual services to attend a non-water facing component.

<b>SERVICE/INTERIM WORK ON BOILER</b> <small>delete as appropriate</small>				Date:		
Engineer name:		Company name:				
Telephone N°:		Gas Safe registration N°:				
Max rate	CO	ppm	CO <sub>2</sub>	%	CO/CO <sub>2</sub>	
Min rate	CO	ppm	CO <sub>2</sub>	%	CO/CO <sub>2</sub>	
Where possible, has a flue integrity check been undertaken in accordance with manufacturers' instructions, and readings are correct?					yes	
Gas rate:	m <sup>3</sup> /h	OR	ft <sup>3</sup> /h			
Electrode changed? <small>delete as appropriate</small>	Yes	No				
Parts fitted:						
System inhibitor concentration has been checked and appropriate action taken, in accordance with BS 7593 and boiler manufacturers' instructions. *					yes	n/a
Comments:						
Signature:						

\*A System inhibitor efficacy test is required on every annual service in accordance with the manufacturers' instructions and BS 7593. It is only acceptable to not have undertaken this if the service engineers attendance visit was in between annual services to attend a non-water facing component.

<b>SERVICE/INTERIM WORK ON BOILER</b> <small>delete as appropriate</small>				Date:		
Engineer name:		Company name:				
Telephone N°:		Gas Safe registration N°:				
Max rate	CO	ppm	CO <sub>2</sub>	%	CO/CO <sub>2</sub>	
Min rate	CO	ppm	CO <sub>2</sub>	%	CO/CO <sub>2</sub>	
Where possible, has a flue integrity check been undertaken in accordance with manufacturers' instructions, and readings are correct?					yes	
Gas rate:	m <sup>3</sup> /h	OR	ft <sup>3</sup> /h			
Electrode changed? <small>delete as appropriate</small>	Yes	No				
Parts fitted:						
System inhibitor concentration has been checked and appropriate action taken, in accordance with BS 7593 and boiler manufacturers' instructions. *					yes	n/a
Comments:						
Signature:						

\*A System inhibitor efficacy test is required on every annual service in accordance with the manufacturers' instructions and BS 7593. It is only acceptable to not have undertaken this if the service engineers attendance visit was in between annual services to attend a non-water facing component.

<b>SERVICE/INTERIM WORK ON BOILER</b> <small>delete as appropriate</small>				Date:		
Engineer name:		Company name:				
Telephone N°:		Gas Safe registration N°:				
Max rate	CO	ppm	CO <sub>2</sub>	%	CO/CO <sub>2</sub>	
Min rate	CO	ppm	CO <sub>2</sub>	%	CO/CO <sub>2</sub>	
Where possible, has a flue integrity check been undertaken in accordance with manufacturers' instructions, and readings are correct?					yes	
Gas rate:	m <sup>3</sup> /h	OR	ft <sup>3</sup> /h			
Electrode changed? <small>delete as appropriate</small>	Yes	No				
Parts fitted:						
System inhibitor concentration has been checked and appropriate action taken, in accordance with BS 7593 and boiler manufacturers' instructions. *					yes	n/a
Comments:						
Signature:						

\*A System inhibitor efficacy test is required on every annual service in accordance with the manufacturers' instructions and BS 7593. It is only acceptable to not have undertaken this if the service engineers attendance visit was in between annual services to attend a non-water facing component.

<b>SERVICE/INTERIM WORK ON BOILER</b> <small>delete as appropriate</small>				Date:		
Engineer name:		Company name:				
Telephone N°:		Gas Safe registration N°:				
Max rate	CO	ppm	CO <sub>2</sub>	%	CO/CO <sub>2</sub>	
Min rate	CO	ppm	CO <sub>2</sub>	%	CO/CO <sub>2</sub>	
Where possible, has a flue integrity check been undertaken in accordance with manufacturers' instructions, and readings are correct?					yes	
Gas rate:	m <sup>3</sup> /h	OR	ft <sup>3</sup> /h			
Electrode changed? <small>delete as appropriate</small>	Yes	No				
Parts fitted:						
System inhibitor concentration has been checked and appropriate action taken, in accordance with BS 7593 and boiler manufacturers' instructions. *					yes	n/a
Comments:						
Signature:						

\*A System inhibitor efficacy test is required on every annual service in accordance with the manufacturers' instructions and BS 7593. It is only acceptable to not have undertaken this if the service engineers attendance visit was in between annual services to attend a non-water facing component.

<b>SERVICE/INTERIM WORK ON BOILER</b> <small>delete as appropriate</small>				Date:		
Engineer name:		Company name:				
Telephone N°:		Gas Safe registration N°:				
Max rate	CO	ppm	CO <sub>2</sub>	%	CO/CO <sub>2</sub>	
Min rate	CO	ppm	CO <sub>2</sub>	%	CO/CO <sub>2</sub>	
Where possible, has a flue integrity check been undertaken in accordance with manufacturers' instructions, and readings are correct?					yes	
Gas rate:	m <sup>3</sup> /h	OR	ft <sup>3</sup> /h			
Electrode changed? <small>delete as appropriate</small>	Yes	No				
Parts fitted:						
System inhibitor concentration has been checked and appropriate action taken, in accordance with BS 7593 and boiler manufacturers' instructions. *					yes	n/a
Comments:						
Signature:						

\*A System inhibitor efficacy test is required on every annual service in accordance with the manufacturers' instructions and BS 7593. It is only acceptable to not have undertaken this if the service engineers attendance visit was in between annual services to attend a non-water facing component.

\* All installations in England and Wales must be notified to Local Authority Building Control (LABC) either directly or through a Competent Persons Scheme. A Building Regulations Compliance Certificate will then be issued to the customer.



# SERVICE & INTERIM BOILER WORK RECORD

It is recommended that your boiler and heating system are regularly serviced and maintained, in line with manufacturers' instructions, and that the appropriate service / interim work record is completed.

## Service provider

When completing a service record (as below), please ensure you have carried out the service as described in the manufacturers' instructions. Always use the manufacturers specified spare parts.

SERVICE/INTERIM WORK ON BOILER <small>delete as appropriate</small>				Date:
Engineer name:		Company name:		
Telephone N°:		Gas Safe registration N°:		
Max rate	CO	ppm	CO <sub>2</sub>	% CO/CO <sub>2</sub>
Min rate	CO	ppm	CO <sub>2</sub>	% CO/CO <sub>2</sub>
Where possible, has a flue integrity check been undertaken in accordance with manufacturers' instructions, and readings are correct?*				yes
Gas rate:	m <sup>3</sup> /h	OR	ft <sup>3</sup> /h	
Were parts fitted? <small>delete as appropriate</small>		Yes	No	
Parts fitted:				
System inhibitor concentration has been checked and appropriate action taken, in accordance with BS 7593 and boiler manufacturers' instructions. *				yes
				n/a
Comments:				
Signature:				

\*A System inhibitor efficacy test is required on every annual service in accordance with the manufacturers' instructions and BS 7593. It is only acceptable to not have undertaken this if the service engineers attendance visit was in between annual services to attend a non-water facing component.

SERVICE/INTERIM WORK ON BOILER <small>delete as appropriate</small>				Date:
Engineer name:		Company name:		
Telephone N°:		Gas Safe registration N°:		
Max rate	CO	ppm	CO <sub>2</sub>	% CO/CO <sub>2</sub>
Min rate	CO	ppm	CO <sub>2</sub>	% CO/CO <sub>2</sub>
Where possible, has a flue integrity check been undertaken in accordance with manufacturers' instructions, and readings are correct?*				yes
Gas rate:	m <sup>3</sup> /h	OR	ft <sup>3</sup> /h	
Were parts fitted? <small>delete as appropriate</small>		Yes	No	
Parts fitted:				
System inhibitor concentration has been checked and appropriate action taken, in accordance with BS 7593 and boiler manufacturers' instructions. *				yes
				n/a
Comments:				
Signature:				

\*A System inhibitor efficacy test is required on every annual service in accordance with the manufacturers' instructions and BS 7593. It is only acceptable to not have undertaken this if the service engineers attendance visit was in between annual services to attend a non-water facing component.

SERVICE/INTERIM WORK ON BOILER <small>delete as appropriate</small>				Date:
Engineer name:		Company name:		
Telephone N°:		Gas Safe registration N°:		
Max rate	CO	ppm	CO <sub>2</sub>	% CO/CO <sub>2</sub>
Min rate	CO	ppm	CO <sub>2</sub>	% CO/CO <sub>2</sub>
Where possible, has a flue integrity check been undertaken in accordance with manufacturers' instructions, and readings are correct?*				yes
Gas rate:	m <sup>3</sup> /h	OR	ft <sup>3</sup> /h	
Were parts fitted? <small>delete as appropriate</small>		Yes	No	
Parts fitted:				
System inhibitor concentration has been checked and appropriate action taken, in accordance with BS 7593 and boiler manufacturers' instructions. *				yes
				n/a
Comments:				
Signature:				

\*A System inhibitor efficacy test is required on every annual service in accordance with the manufacturers' instructions and BS 7593. It is only acceptable to not have undertaken this if the service engineers attendance visit was in between annual services to attend a non-water facing component.

SERVICE/INTERIM WORK ON BOILER <small>delete as appropriate</small>				Date:
Engineer name:		Company name:		
Telephone N°:		Gas Safe registration N°:		
Max rate	CO	ppm	CO <sub>2</sub>	% CO/CO <sub>2</sub>
Min rate	CO	ppm	CO <sub>2</sub>	% CO/CO <sub>2</sub>
Where possible, has a flue integrity check been undertaken in accordance with manufacturers' instructions, and readings are correct?*				yes
Gas rate:	m <sup>3</sup> /h	OR	ft <sup>3</sup> /h	
Were parts fitted? <small>delete as appropriate</small>		Yes	No	
Parts fitted:				
System inhibitor concentration has been checked and appropriate action taken, in accordance with BS 7593 and boiler manufacturers' instructions. *				yes
				n/a
Comments:				
Signature:				

\*A System inhibitor efficacy test is required on every annual service in accordance with the manufacturers' instructions and BS 7593. It is only acceptable to not have undertaken this if the service engineers attendance visit was in between annual services to attend a non-water facing component.

SERVICE/INTERIM WORK ON BOILER <small>delete as appropriate</small>				Date:
Engineer name:		Company name:		
Telephone N°:		Gas Safe registration N°:		
Max rate	CO	ppm	CO <sub>2</sub>	% CO/CO <sub>2</sub>
Min rate	CO	ppm	CO <sub>2</sub>	% CO/CO <sub>2</sub>
Where possible, has a flue integrity check been undertaken in accordance with manufacturers' instructions, and readings are correct?*				yes
Gas rate:	m <sup>3</sup> /h	OR	ft <sup>3</sup> /h	
Were parts fitted? <small>delete as appropriate</small>		Yes	No	
Parts fitted:				
System inhibitor concentration has been checked and appropriate action taken, in accordance with BS 7593 and boiler manufacturers' instructions. *				yes
				n/a
Comments:				
Signature:				

\*A System inhibitor efficacy test is required on every annual service in accordance with the manufacturers' instructions and BS 7593. It is only acceptable to not have undertaken this if the service engineers attendance visit was in between annual services to attend a non-water facing component.

SERVICE/INTERIM WORK ON BOILER <small>delete as appropriate</small>				Date:
Engineer name:		Company name:		
Telephone N°:		Gas Safe registration N°:		
Max rate	CO	ppm	CO <sub>2</sub>	% CO/CO <sub>2</sub>
Min rate	CO	ppm	CO <sub>2</sub>	% CO/CO <sub>2</sub>
Where possible, has a flue integrity check been undertaken in accordance with manufacturers' instructions, and readings are correct?*				yes
Gas rate:	m <sup>3</sup> /h	OR	ft <sup>3</sup> /h	
Were parts fitted? <small>delete as appropriate</small>		Yes	No	
Parts fitted:				
System inhibitor concentration has been checked and appropriate action taken, in accordance with BS 7593 and boiler manufacturers' instructions. *				yes
				n/a
Comments:				
Signature:				

\*A System inhibitor efficacy test is required on every annual service in accordance with the manufacturers' instructions and BS 7593. It is only acceptable to not have undertaken this if the service engineers attendance visit was in between annual services to attend a non-water facing component.

\* All installations in England and Wales must be notified to Local Authority Building Control (LABC) either directly or through a Competent Persons Scheme. A Building Regulations Compliance Certificate will then be issued to the customer.







17962.3487.0 2522 76A5 UK

**Biasi UK Ltd**  
Commercial Road  
Leamore Enterprise Park  
WALSALL

WS2 7NQ

Sales Tel. 01922 714600  
Tech. Service Tel. 01922 714636  
[www.biasi.co.uk](http://www.biasi.co.uk)

