

---

Wall hung, fanflue, roomsealed, high efficiency gas boiler

## Service manual

### BASICA COND

Product name	Models	G.C. Appl. No.
<b>BASICA COND 24C</b>	<b>M275V.2024 SM</b>	<b>47-583-49</b>
<b>BASICA COND 28C</b>	<b>M275V.2428 SM</b>	<b>47-583-50</b>
<b>BASICA COND 32C</b>	<b>M275V.2832 SM</b>	<b>47-583-51</b>

Leave this manual adjacent to the gas meter

**Warning:**

Service / repairs must be carried out, only by a qualified Gas Safe Registered Engineer, who will be responsible for the current Regulations for gas appliances.



**Note:**

After servicing, complete the relevant Service Interval Record section of the Benchmark Checklist of the user and installation manual.





# TABLE OF CONTENTS

<p><b>1 OVERALL INFORMATION.....4</b></p> <p>1.1 Overall View .....4</p> <p>1.2 Hydraulic diagram .....4</p> <p><b>2 GENERAL ACCESS AND EMPTYING HYDRAULIC CIRCUITS.....5</b></p> <p>2.1 Nomenclature .....5</p> <p>2.2 Case panels.....5</p> <p>2.3 Control panel .....5</p> <p>2.4 Main electronic p.c.b. box .....6</p> <p>2.5 Emptying the primary circuit .....7</p> <p>2.6 Emptying the D.H.W. circuit.....7</p> <p><b>3 DIAGRAMS .....8</b></p> <p>3.1 Wiring diagram M275V SM .....8</p> <p>3.2 Circuit voltages .....9</p> <p><b>4 FAULT FINDING.....10</b></p> <p>4.1 Display diagnostic .....12</p> <p>4.2 Error history (view only).....12</p> <p>4.3 Programming the maintenance period .....12</p> <p><b>5 CONDENSING HEAT EXCHANGER.....14</b></p> <p>5.1 Function.....14</p> <p>5.2 Removal .....14</p> <p>5.3 Cleaning .....15</p> <p><b>6 D.H.W. HEAT EXCHANGER .....16</b></p> <p>6.1 Function.....16</p> <p>6.2 Removal .....16</p> <p><b>7 PUMP .....17</b></p> <p>7.1 Function.....17</p> <p>7.2 Removal pump head .....17</p> <p><b>8 THREE WAY DIVERTER VALVE.....18</b></p> <p>8.1 Function.....18</p> <p>8.2 Checks.....18</p> <p>8.3 Removal of the electric actuator .....18</p> <p>8.4 Removal of the three way diverter valve .....18</p> <p>8.5 Removal of the diverter group .....19</p> <p><b>9 MAIN ELECTRONIC CONTROL/IGNITION P.C.B.....20</b></p> <p>9.1 Function.....20</p> <p>9.2 Selection and adjustment devices .....21</p> <p>9.3 Checking the temperature.....21</p> <p>9.4 Setting the boiler control function modes .....22</p> <p>9.5 Checks.....24</p> <p>9.6 Removal of the electronic control p.c.b. ....24</p> <p>9.7 Thermal control in the  mode .....26</p> <p>9.8 Thermal control in the  mode .....27</p> <p><b>10 CONTROL PANEL ELECTRONIC P.C.B. ....28</b></p> <p>10.1 Function.....28</p> <p>10.2 Normally information .....28</p> <p><b>11 GAS VALVE .....30</b></p> <p>11.1 Function.....30</p> <p>11.2 Description of the parts .....30</p> <p>11.3 Adjustment - Chimney Sweep Function .....30</p> <p>11.4 Checks.....32</p> <p>11.5 Removal of the gas valve .....32</p>	<p><b>12 PRIMARY CIRCUIT PRESSURE SWITCH .....34</b></p> <p>12.1 Function.....34</p> <p>12.2 Removal .....34</p> <p><b>13 EXPANSION VESSEL AND PRESSURE GAUGE .....35</b></p> <p>13.1 Function.....35</p> <p>13.2 Checks.....35</p> <p>13.3 Removal of the expansion vessel .....35</p> <p><b>14 D.H.W. FLOW SWITCH, FILTER AND FLOW LIMITER ..36</b></p> <p>14.1 Function.....36</p> <p>14.2 Description and location of parts - (Figure 14.2 - Figure 14.3) .....36</p> <p>14.3 Removal of the sensor.....36</p> <p>14.4 Checks.....36</p> <p>14.5 Removal of the flow switch group and D.H.W. circuit filter ..37</p> <p><b>15 NTC HEATING DELIVERY PROBE - NTC MAXIMUM TEMPERATURE AND D.H.W. TEMPERATURE PROBE NTC .....38</b></p> <p>15.1 Function.....38</p> <p>15.2 Checks.....38</p> <p>15.3 Removal of the NTC heating delivery probe - NTC maximum temperature.....38</p> <p>15.4 Removal of the D.H.W. temperature probe NTC.....38</p> <p><b>16 BY-PASS VALVE .....40</b></p> <p>16.1 Function.....40</p> <p>16.2 Removal .....40</p> <p><b>17 FAN AND AIR BOX .....41</b></p> <p>17.1 Function.....41</p> <p>17.2 Removal of the Air box and the Fan .....41</p> <p><b>18 IGNITION / DETECTION ELECTRODE AND BURNER ..42</b></p> <p>18.1 Function.....42</p> <p>18.2 Removal of the ignition / detection electrode.....42</p> <p>18.3 Removal of the front insulation panel .....42</p> <p>18.4 Removal of the burner.....42</p> <p>18.5 Removal of the rear insulation.....43</p> <p>18.6 Checks.....43</p> <p><b>19 FLUE TEMPERATURE PROBE NTC AND SAFETY THERMAL FUSE .....45</b></p> <p>19.1 Function.....45</p> <p>19.2 Removal .....45</p> <p>19.3 Checks.....45</p> <p><b>20 CONDENSATE TRAP .....47</b></p> <p>20.1 Function.....47</p> <p>20.2 Check the cleanness of the trap .....47</p> <p>20.3 Removal .....47</p> <p><b>21 SHORT SPARE PARTS LIST .....48</b></p>
---	---

# OVERALL INFORMATION

## 1 OVERALL INFORMATION

### 1.1 Overall View

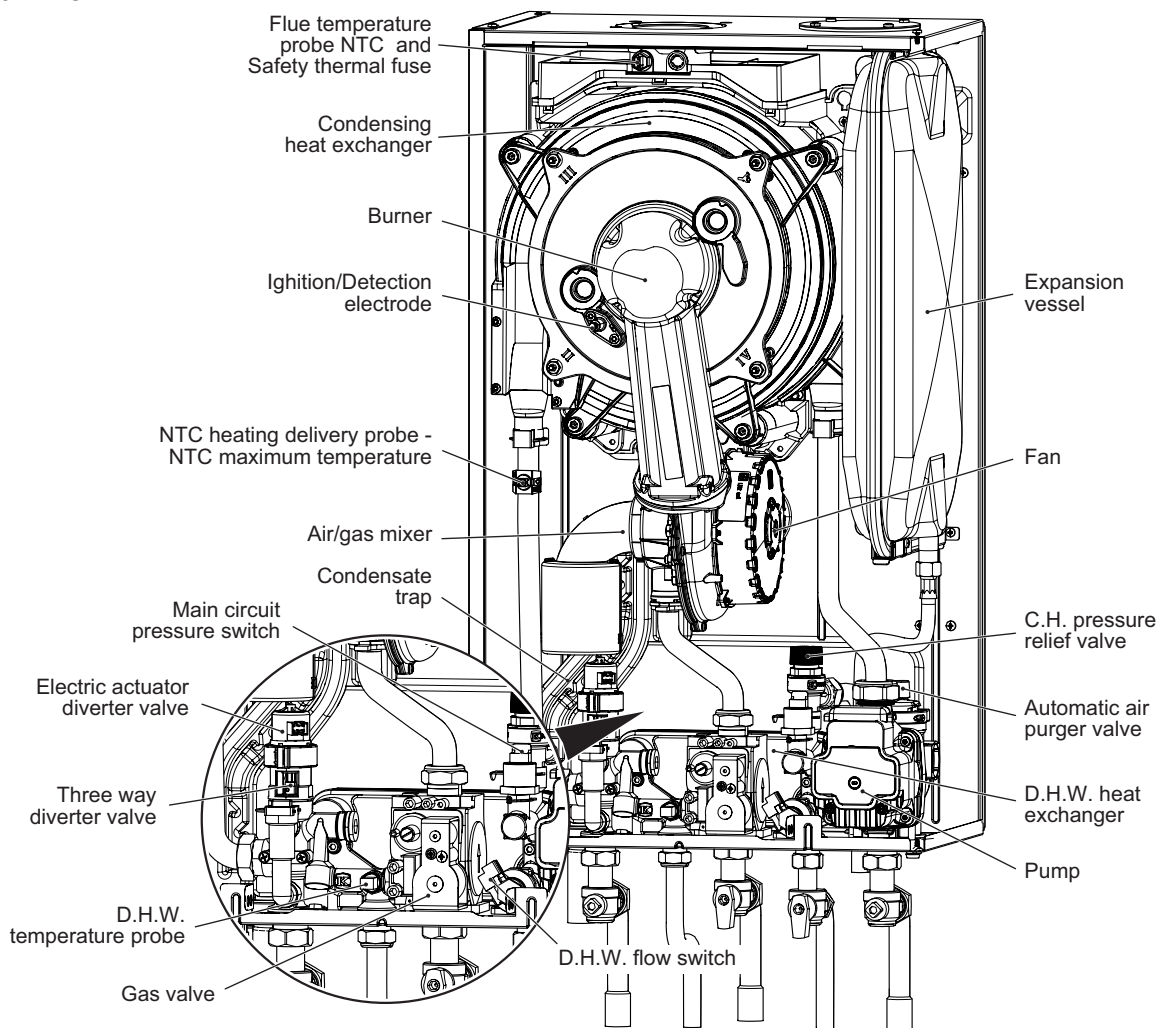

Figure 1.1

### 1.2 Hydraulic diagram

Central heating (C.H.) operation

Domestic hot water (D.H.W.) operation

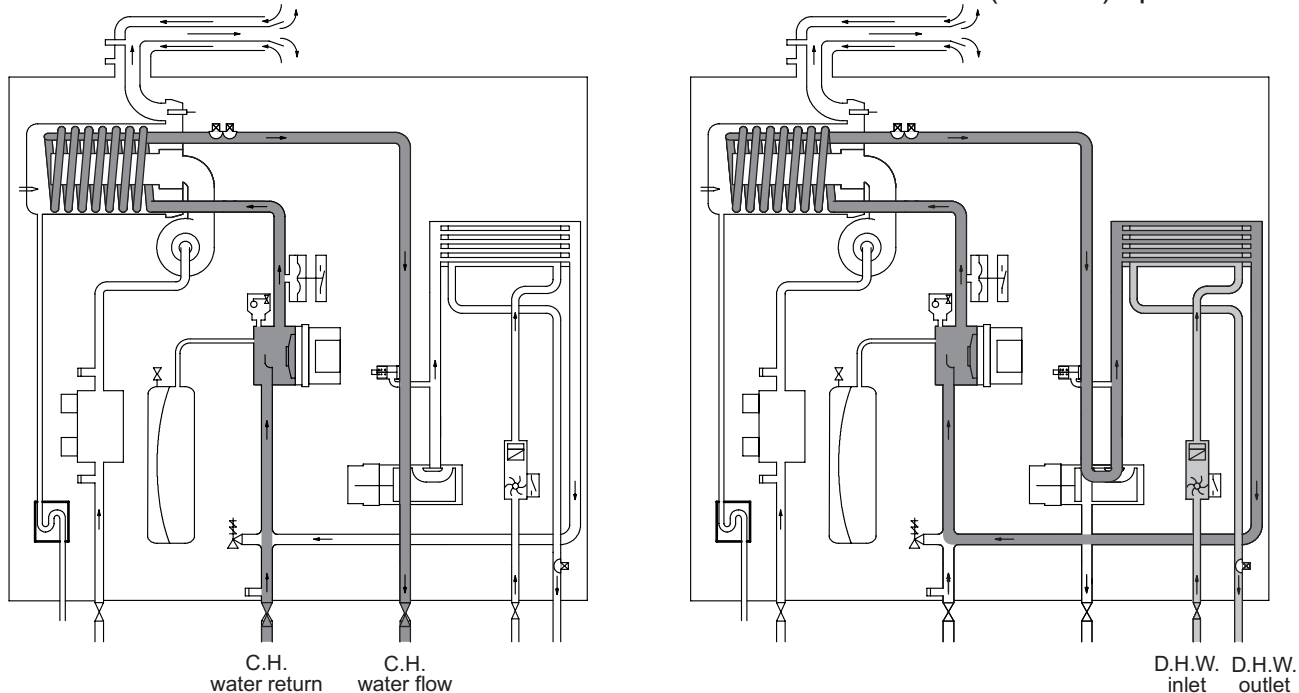

Figure 1.2

# GENERAL ACCESS AND EMPTYING HYDRAULIC CIRCUITS

## 2 GENERAL ACCESS AND EMPTYING HYDRAULIC CIRCUITS

### 2.1 Nomenclature

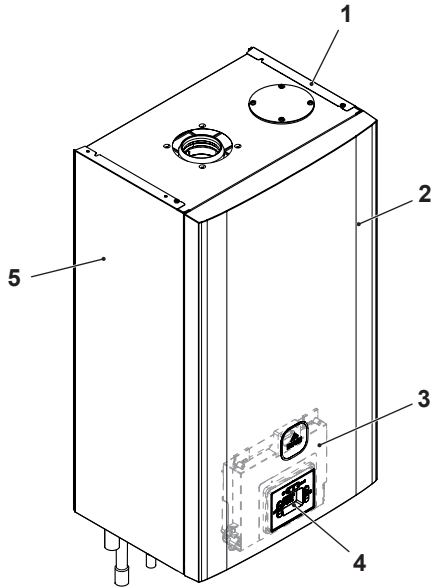

Figure 2.1

- 1 Right side panel
- 2 Front panel
- 3 Main electronic p.c.b. box
- 4 Control panel
- 5 Left side panel

### 2.2 Case panels



**Warning:** isolate the boiler from the mains electricity supply before removing any covering or component.

For the most part of the check and maintenance operations it is necessary to remove one or more panels of the case.

The side panels can be removed only after the removal of the front panel.

To remove the front panel loosen screws "6" (Figure 2.2), lift the panel and remove it.

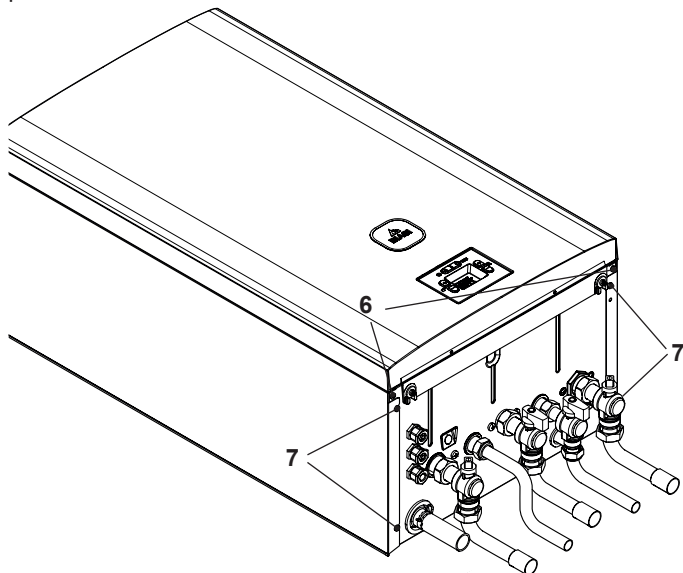

Figure 2.2 - Bottom view of the boiler

Pull the lower part of the front panel and lift it upwards (Figure 2.3).

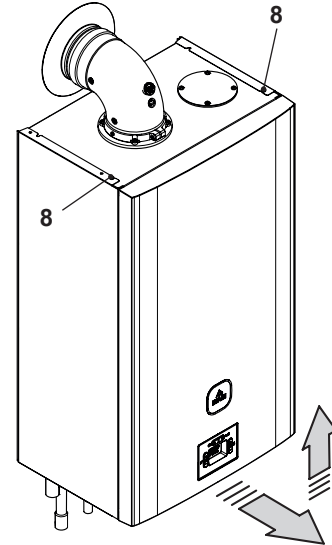

Figure 2.3

To remove the side panels loosen the screws "7" (Figure 2.2) and "8" (Figure 2.3).

Pull the side panels towards the outside.

### To Fit the case panels

Fit the side case panels.



**Warning:** Fit the front panel hooking it on the upper side.

Fit the side panels and the front panel in the reverse order to that described above.

### 2.3 Control panel



**Warning:** isolate the boiler from the mains electricity supply before removing any covering or component.

To gain access to the parts located inside the control panel proceed as follows:

- 1 Remove the front panel of the case
- 2 Unscrew the screw "9" and turn the control panel "10" (Figure 2.4).

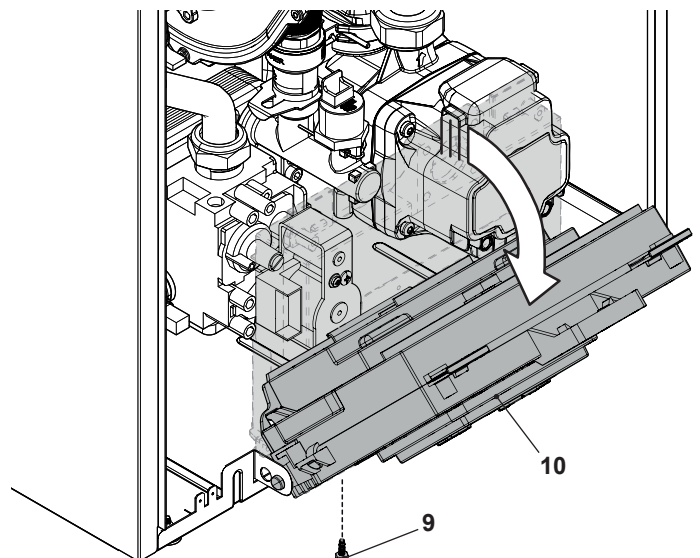

Figure 2.4

## GENERAL ACCESS AND EMPTYING HYDRAULIC CIRCUITS

### 2.4 Main electronic p.c.b. box



**Warning:** isolate the boiler from the mains electricity supply before removing any covering or component.

#### Terminal block lid removal

To gain access to the parts located inside the control panel proceed as follows:

- 1 Remove the front panel of the case.
- 2 Turn the control panel "11" (see section "2.3 Control panel" on page 5).
- 3 Unscrew the screw "12" and lift the cover "13" to access the electric power supply terminal block, remote and external sensor (Figure 2.5).

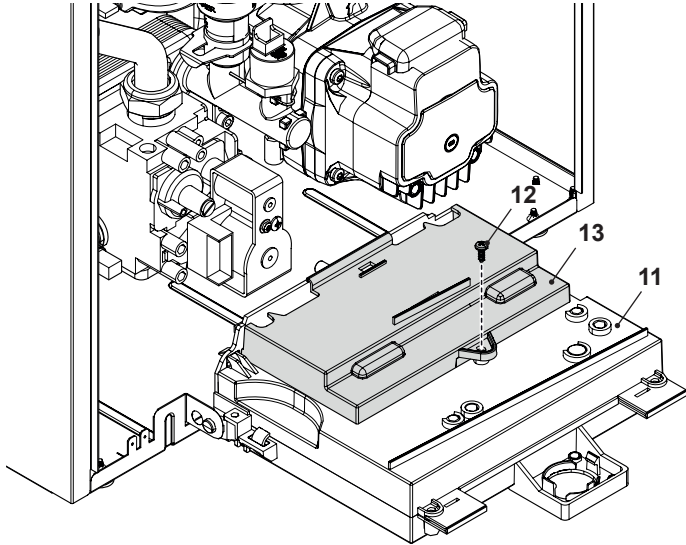

Figure 2.5

- 4 Rotate the lid (Figure 2.6).

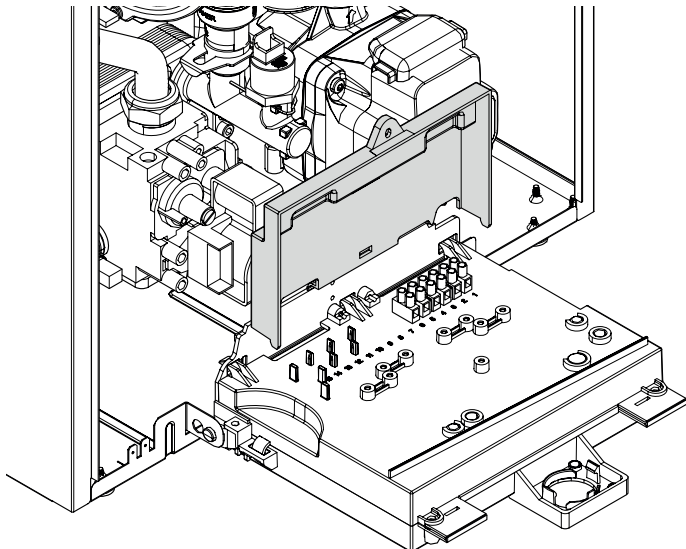

Figure 2.6

#### Main electronic p.c.b. lid removal

To get access to the main electronic p.c.b.:

- 5 Unscrew the screw "14" (Figure 2.7).

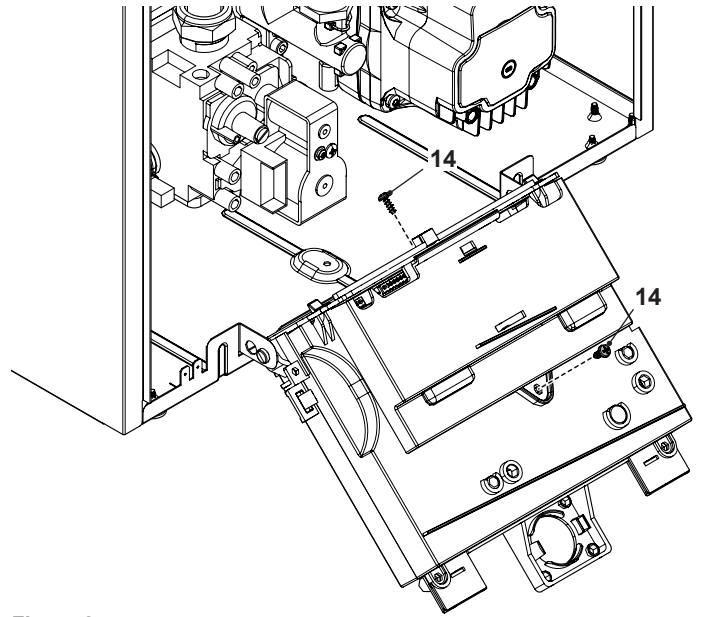

Figure 2.7

- 6 Free the hooks indicated and rotate the cover "16" and the lids "15" (Figure 2.8).

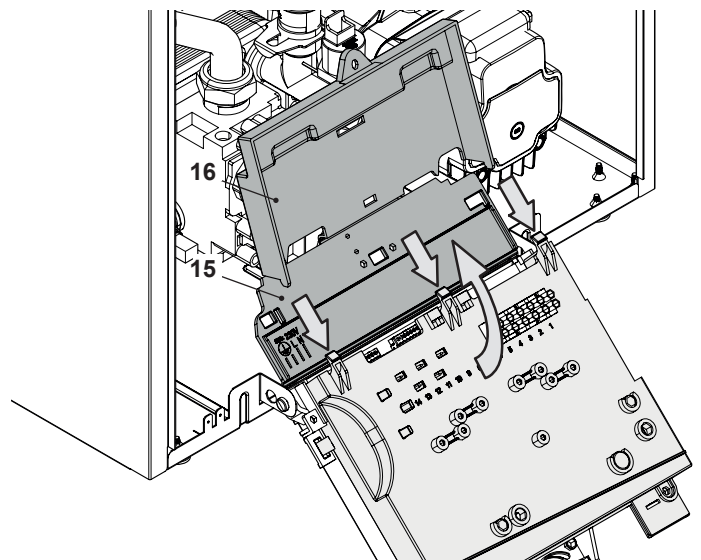

Figure 2.8

- 7 Free the hooks indicated and rotate the cover "17" (Figure 2.9).

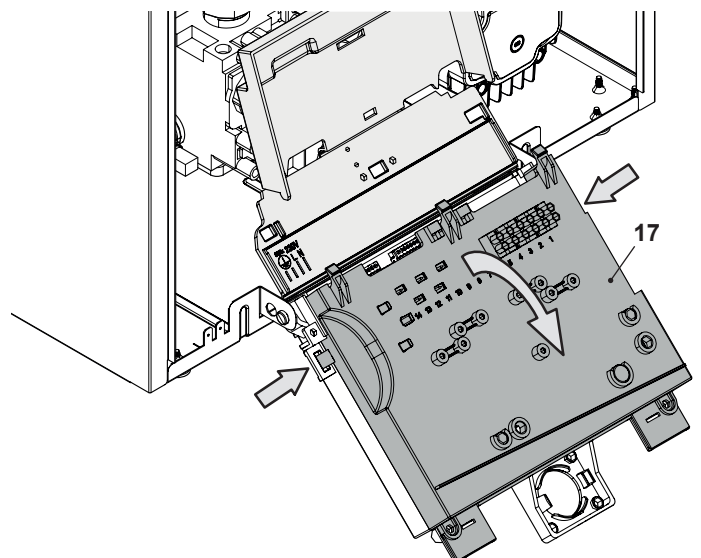

Figure 2.9

## GENERAL ACCESS AND EMPTYING HYDRAULIC CIRCUITS

### 2.5 Emptying the primary circuit

- 1 Close the C.H. circuit flow and return cocks "18" (Figure 2.10).

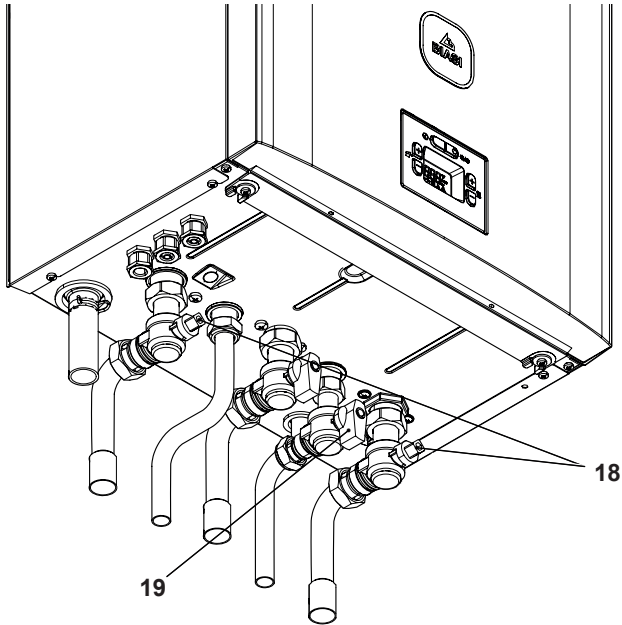

Figure 2.10

- 2 Remove the front and right panels of the boiler.
- 3 Loosen the central heating drain cock "20" (Figure 2.11) until the boiler is completely emptied.

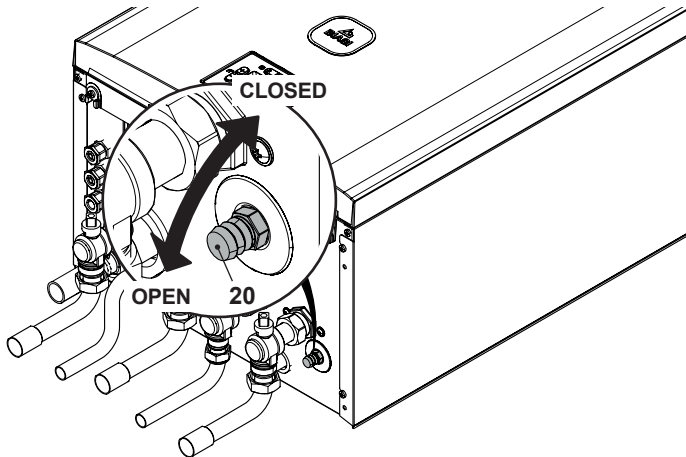

Figure 2.11

- 4 To make draining easier, lift the plug "21" of the automatic relief valve in Figure 2.12.

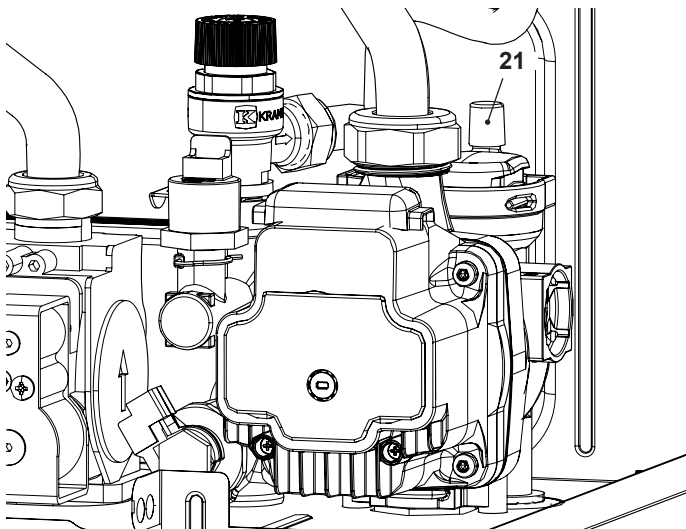

Figure 2.12

### 2.6 Emptying the D.H.W. circuit

- 1 Close the D.H.W. inlet cock "19" (Figure 2.10).
- 2 Open one or more hot water taps until the boiler has been completely emptied.

# DIAGRAMS

## 3 DIAGRAMS

### 3.1 Wiring diagram M275V SM

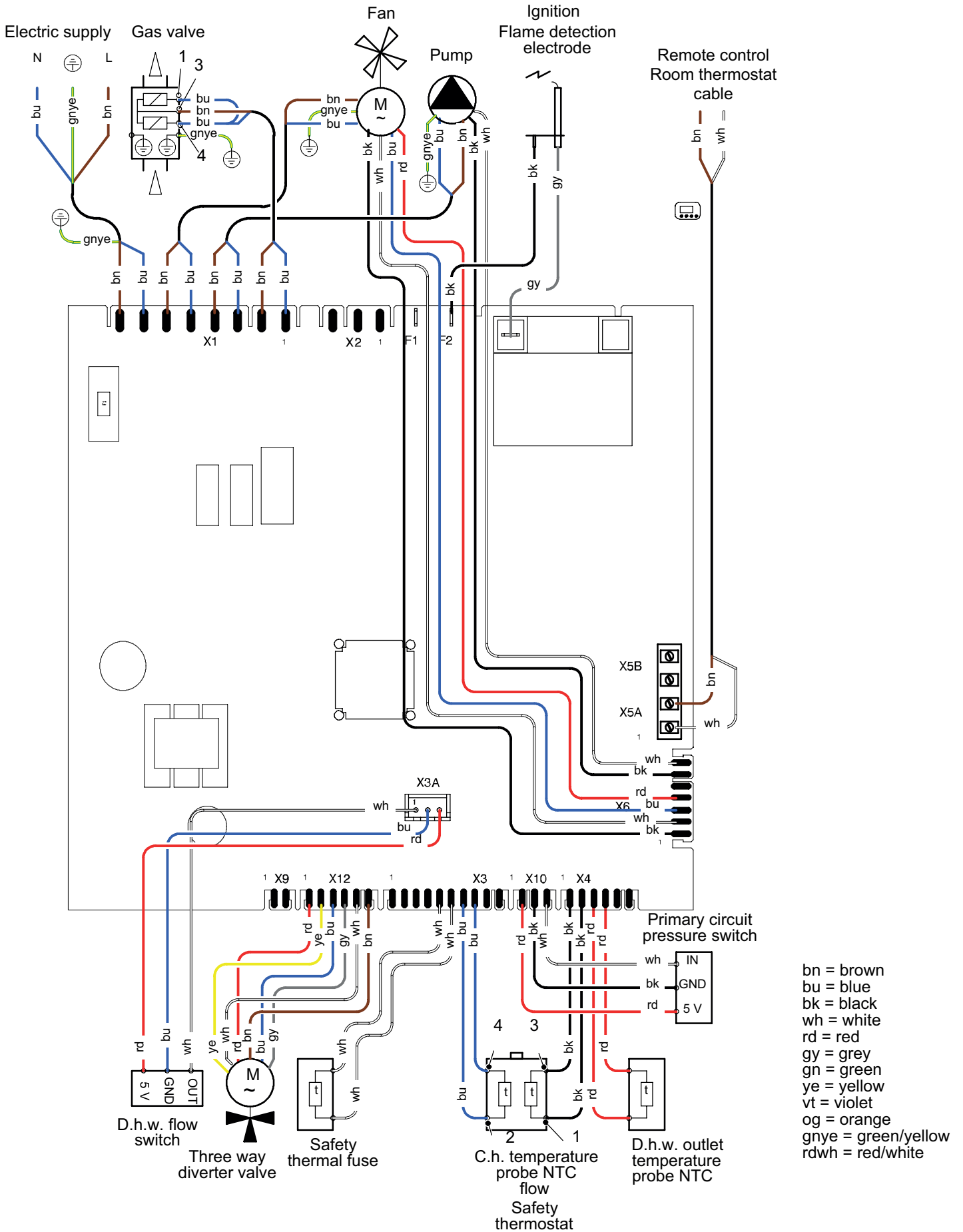





Figure 3.1



# DIAGRAMS

## 3.2 Circuit voltages

Electrical voltages or frequency with burner on

-  during c.h. or d.h.w. operation
-  only during c.h. operation only
-  during d.h.w. operation

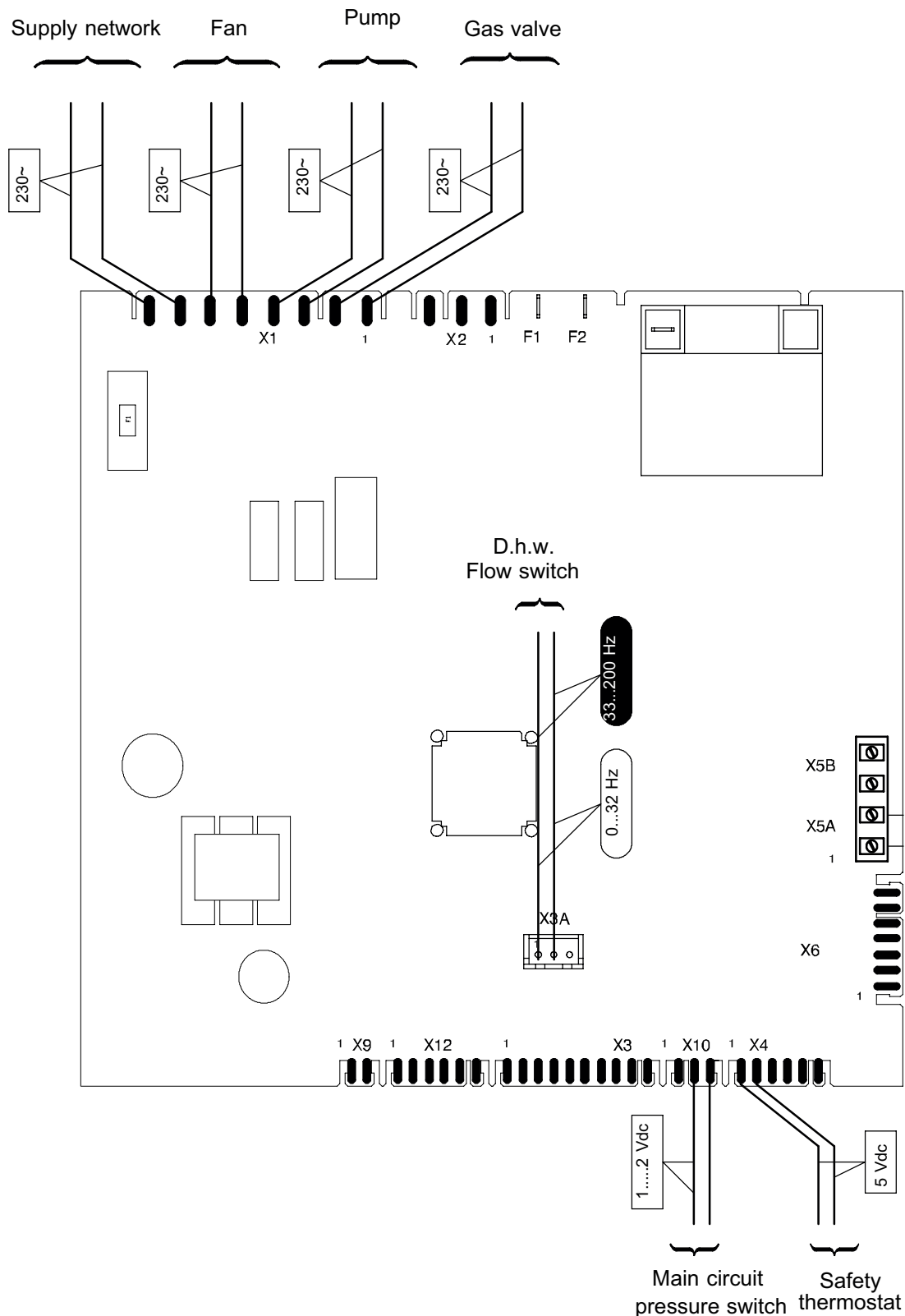

Figure 3.2

## FAULT FINDING

### 4 FAULT FINDING

#### FAULT FINDING

Section of the manual → (note ref. in brackets)	Components to check																																													
	(1)	(2)	(3)	21.1	(4)	5	6	7.2	8.2	14.3	9.5			10	11.4	12.2	14.5	15.2		16	17	18.4	19.2	19.2	20.1	(7)	-	-																		
Defect ↓	Power supply line	Gas supply line	Flue pipes	Cond. drain pipe and trap	C.H. circuit	D.H.W. circuit	Condensing heat exchanger	D.H.W. heat exchanger	Pump	Diverter valve	D.H.W. flow switch	Fuses (Electronic p.c.b.)	Main electronic p.c.b.	Boiler settings	Control panel electr. p.c.b.	Gas valve	Main circuit pressure switch	D.H.W. filter	Main circuit temp. probe	D.H.W. temp. probe	By-pass valve	Fan / air restrictor	Ignition / Detection electrode	Safety thermostat	Gas restrictor	Flue temp. probe NTC	Expansion vessel	Safety valve	Pressure gauge	External temp. probe																
Appliance lock-out (*)	A	A	B	B	B	C	C	B	B				A		D	A						C	B									A														
<b>E01 + RESET</b>																																														
<b>E02 + RESET</b>																																														
<b>E03 + RESET</b>													A																																	
<b>E04 + ⚠</b>																																														
<b>E05 + ⚠</b>																																														
<b>E06 + ⚠</b>																																														
<b>E07 + ⚠</b>																																														
<b>E08 + ⚠</b>																																														
<b>E09 + ⚠</b>																																														
<b>E10 + ⚠</b>			A																																											
<b>E11 + RESET</b>			A																																											
<b>E14 + ⚠</b>																																														
<b>E22 + RESET</b>																																														
<b>E25 + ⚠</b>																																														
<b>E26 + RESET</b>																																														
<b>E28 + ⚠</b>																																														
<b>E50 + ⚠</b>													A																																	
<b>E52 + RESET</b>																																														
<b>E54 + RESET</b>																																														
<b>E58 + RESET</b>																																														

Display indicates "E"

The letter in the cells indicates the possible fault cause.  
A.....Z indicates the most probably (A) to less probably (...Z)

# FAULT FINDING

## FAULT FINDING

Section of the manual → (note ref. in brackets)	Components to check																														
	(1)	(2)	(3)	21.1	- (4)	5	6	7.2	8.2	14.3	9.5			10	11.4	12.2	14.5	15.2		16	17	18.4	19.2	19.2	20.1	(7)	-	-			
Defect → Appliance lock-out (*)	Power supply line	Gas supply line	Flue pipes	Cond. drain pipe and trap	C.H. circuit	D.H.W. circuit	Condensing heat exchanger	D.H.W. heat exchanger	Pump	Diverter valve	D.H.W. flow switch	Fuses (Electronic p.c.b.)	Main electronic p.c.b.	Boiler settings	Control panel electr. p.c.b.	Gas valve	Main circuit pressure switch	D.H.W. filter	Main circuit temp. probe	D.H.W. temp. probe	By-pass valve	Fan / air restrictor	Ignition electrode / Detection electrode	Safety thermostat	Gas restrictor	Flue temp. probe NTC	Expansion vessel	Safety valve	Pressure gauge	External temp. probe	
The boiler does not start either in C.H. or D.H.W. mode. The control panel display OFF Fan still.	•											•	•	•	•																
The boiler does not supply D.H.W. (cold water from the tap). Regular operation in C.H. mode even during a drawing off D.H.W.									•	•		•	•																		
On C.H. mode the temperature of the main circuit reaches 90°C and the C.H. system does not heat. The boiler operates correctly on D.H.W. mode.									•	•		•	•																		
Incorrect modulation.												•	•								•										
Noisy boiler.	•		•													•					•										
Poor C.H. / D.H.W. temperature (9).	•		•									•	•												•						
Poor D.H.W. temperature. Regular operation in C.H. mode.										•											•										
Low D.H.W. flow rate.																															
Water leaks from the safety valve during operation on C.H.																															
Water leaks from the safety valve when the boiler is off.																															















- \* Lock out is indicated as "E" on the display.
- Note**  
Useful information can be obtained also from the optical indication given by the appliance display (see section 4.1).
- 1 Check for 230V~ between line (L) and neutral (N).  
Verify the integrity of supply cable, plug and external fuses.  
Check the polarity of line and neutral connection.
  - 2 Check the gas supply pipe and isolation tap for gas tightness.
  - 3 Check for soundness and absence of obstructions. Verify that the flue terminal is correctly installed (see clearances) and ensure that exhaust gas is not sucked back by the boiler.
  - 4 Check for soundness of the circuit and verify its correct filling (see also installation manual).
  - 5 A jammed by-pass could cause the over-heating of the main circuit and the intervention of the safety thermostat.
  - 6 Using the flue analyser, check the CO<sub>2</sub> value of the flue gases.
  - 7 Check the pressurization of the expansion vessel. Refer to the installation manual for proper values.
  - 8 D.H.W. pressure too high or flow rate too high. If necessary insert a flow rate limiter (14.6).
  - 9 The boiler doesn't reach the nominal heat input.

# FAULT FINDING

## 4.1 Display diagnostic

The display indications provide help in the diagnosis of fault finding.

The control panel display gives other information for the user. The following table gives fault code, error and the reason for the fault.

E01 + <b>RESET</b>	Safety lockout due to failed ignition.
E02 + <b>RESET</b>	Lockout due to safety thermostat.
E03 + <b>RESET</b>	Generic lockout.
E04 + 	Pump circulation failure, insufficient system pressure or water pressure sensor not connected.
E05 + 	Control anomaly: fan.
E06 + 	NTC heating delivery probe failure.
E07 + 	D.H.W. NTC probe failure / Hot water tank sensor failure.
E08 + 	External NTC probe failure.
E09 + 	Flue gas NTC probe failure (interruption).
E10 + 	Lockout due to tripping of the flue gas probe and thermal fuse.
E11 + 	Parasite flame.
E12 + 	Return NTC probe failure.
E13 + 	Central Heating pressure high.
E14 + 	Temperature gradient circulation failure (>2K/s).
E22 + <b>RESET</b>	Heating delivery temperature between 90°C and 100°C.
E25 + 	Boiler in antifreeze.
E26 + <b>RESET</b>	Gas valve fault.
E28 + 	Tank NTC probe failure.
E50 + 	OT communication fault.
E52 + <b>RESET</b>	Maximum number of remote unlock attempts.
E54 + <b>RESET</b>	Filling function of C.H. water completed, but pressure is lower than the minimum pressure for boiler filling.
E58 + <b>RESET</b>	Filling function of C.H. water completed, but pressure is higher than the maximum pressure for boiler filling.
 5Er 20°C	Next maintenance period expiring. Enter the "INFO mode" to view the remaining weeks before maintenance is due

## 4.2 Error history (view only)

- 1 To enter in the "INFO mode" press the key "G" (Figure 4.1) and hold in for 5 second until the LCD display indicates the code **n02** Figure 4.2.

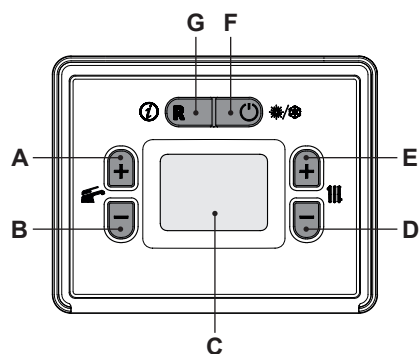

Figure 4.1



Figure 4.2

- 2 Scroll the various fault code using keys "A" (previous INFO) or "B" (next INFO) (Figure 4.1) until the LCD display indicates the code:
  - **n21** (last error code);
  - **n22** (second-to-last error code);
  - **n29** (weeks remaining before the end of the programmed maintenance period).
- 3 To exit the parameters menu.
  - press the "F" key for 5 seconds (Figure 4.1) (return to previous level).

## 4.3 Programming the maintenance period

- 1 To enter in the parameters setting mode press at the same time the 2 keys "F" and "G" (Figure 4.3) and hold in for 5 second until the display shows the code **P00**, indicating entry into "parameter P00" (Figure 4.4).

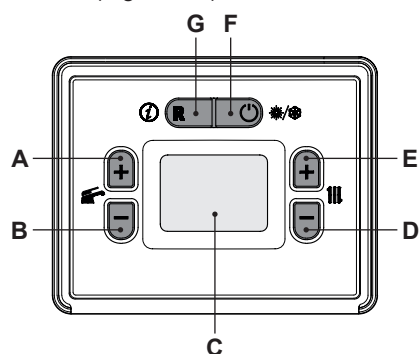

Figure 4.3



Figure 4.4

- 2 Scroll the various menus using keys "A" or "B" (Figure 4.3) until the LCD display indicates the letters **Cod** (Figure 4.5) and then displays three dashes "- - -".



**Figure 4.5**

- 3 Press the "E" key to set "1 -", then press "A" to confirm the 1 and go to the next segment.
- 4 Press the "E" key to set "1 9 -", then press "A" to confirm the 9 and go to the next segment.
- 5 Press the "E" key to set "1 9 8", then press "A" to confirm the 8 and go back to the list of parameters
- 6 Press "A" and hold until the LCD display shows the code **A51**, indicating entry into "parameter A51" (Figure 4.6).



**Figure 4.6**

- 7 By using keys "D" or "E" (Figure 4.3) it is possible to modify the value of parameter A51 from 1 to 52 weeks (52 = 1 year).
- 8 Press "A" or "B" (Figure 4.3) to confirm the value entered and return to the list of parameters (Figure 4.6).
- 9 Press "B" and hold until the LCD display shows the code **A50**, indicating entry into "parameter A50" (Figure 4.7).



**Figure 4.7**

- 10 By using keys "D" or "E" (Figure 4.3) it is possible to modify the value of parameter A51:  
**00** = maintenance period not activated  
**01** = maintenance period activated
- 11 Press "A" or "B" (Figure 4.3) to confirm the value entered and return to the list of parameters (Figure 4.7).
- 12 Press the "F" key (Figure 4.3) to exit "programming mode".

# CONDENSING HEAT EXCHANGER

## 5 CONDENSING HEAT EXCHANGER

### 5.1 Function

The Condensing heat exchanger "1" in Figure 5.1 has the function of transferring heat produced from combustion of the gas and from the flue exhausted gas to the water circulating in it.

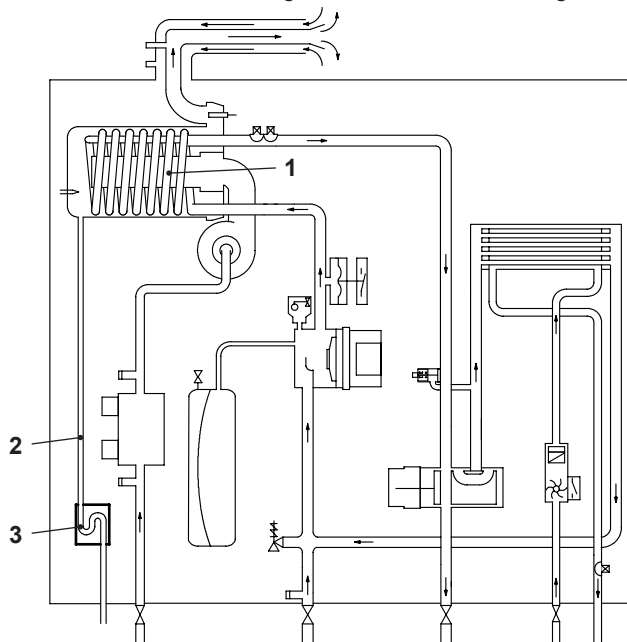

Figure 5.1

By reducing the combustion products temperature, the latent heat of the vapour is transferred to the water circuit, allowing an extra gain of useful heat.

The condensed vapour is then drained through the condensate trap "3" and the draining pipe "2".

### 5.2 Removal



**Warning: isolate the boiler from the mains electricity supply before removing any covering or component.**

- 1 Disconnect the flue system from the boiler.
- 2 Remove the fan group (rubber pipe, gas pipe) following the instructions from 1 to 6 in section "17.2 Removal of the Air box and the Fan" on page 41.
- 3 Disconnect the detection / ignition electrode connector "4".
- 4 Disconnect the fan connector "5" by pressing the plastic hook placed on the side of the connector (Figure 5.2).
- 5 Unscrew the nuts "6" (Figure 5.2).
- 6 Remove the fan-burner group "7".
- 7 Empty the primary circuit of the boiler.
- 8 Remove the clips "8" (Figure 5.2).
- 9 Loosen the connection "10" and slightly move the pipe "9" upwards, turn it towards left (Figure 5.2) and then move the pipe downwards freeing it from the Condensing heat exchanger.
- 10 Loosen the connection "11" and slightly move the pipe "12" upwards, turn it towards left (Figure 5.2) and then move the pipe downwards freeing it from the Condensing heat exchanger.

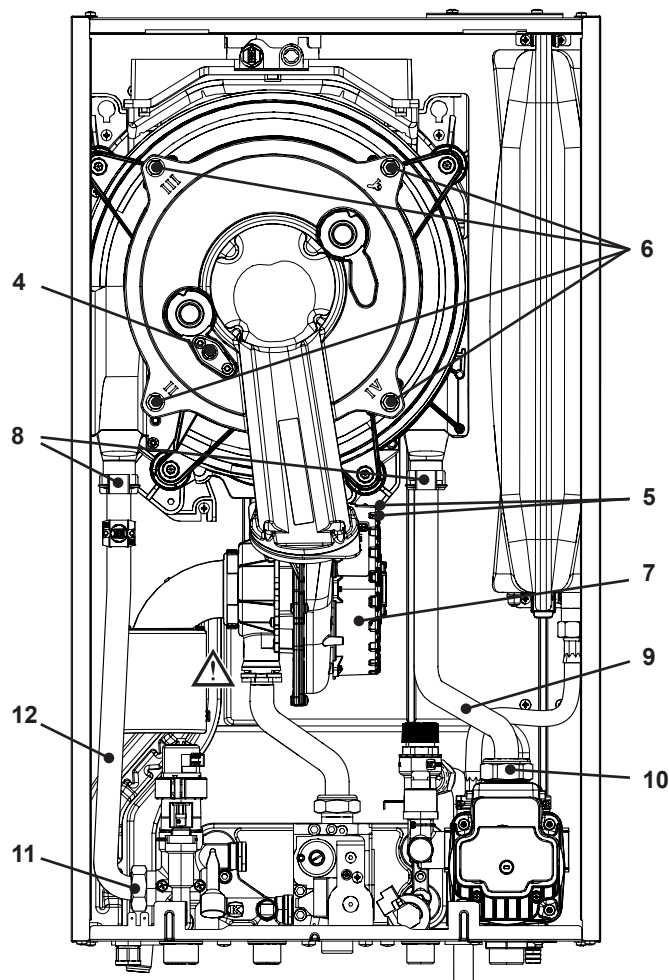

Figure 5.2

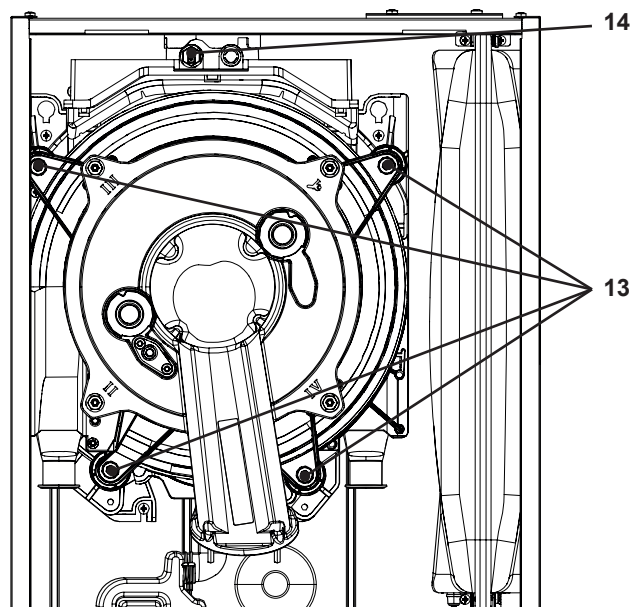

Figure 5.3

- 11 Unscrew the screws "13" and remove the clamps (Figure 5.3).
- 12 Disconnect the connector "14" by pressing the plastic hook placed on the side of the connector (Figure 5.3).
- 13 Remove the Condensing heat exchanger by levering it and sliding it forwards.
- 14 Reassemble the Condensing heat exchanger carrying out the removal operations in reverse order.

---

## CONDENSING HEAT EXCHANGER

---

Ensure to tighten the nuts "6" - Figure 5.2 firmly.

### 5.3 Cleaning

If there are deposits of dirt on the coil of the Condensing heat exchanger, clean with a bristle paintbrush and remove the dust with a Hoover.



**Warning:** After cleaning or replacement as detailed above, it is deemed necessary to undertake a combustion analysis as detailed in chapter "11.3 Adjustment - Chimney Sweep Function" on page 30.

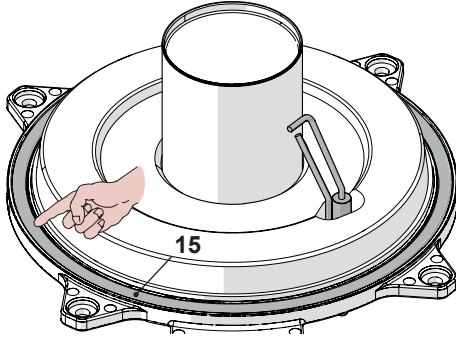

Figure 5.4

#### Caution:

After any periodical servicing or disturbance the combustion chamber silicon seal "15" Figure 5.4 must be fully inspected and replaced at the discretion of the service engineer.

After any disturbance to the chamber door seal the appliance must undergo a full analytical combustion performance check.



**Remove any limescale from the detection electrode and replace it if worn.**

## 6 D.H.W. HEAT EXCHANGER

### 6.1 Function

The D.H.W. heat exchanger "1" in Figure 6.1 and Figure 6.3 allows the instantaneous transfer of heat from the primary hydraulic circuit to the water destined for D.H.W. use.

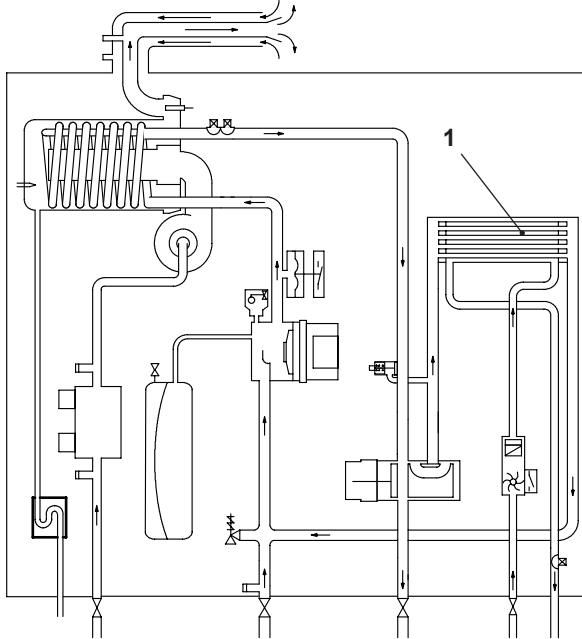

Figure 6.1

The schematic structure is shown in Figure 6.2.

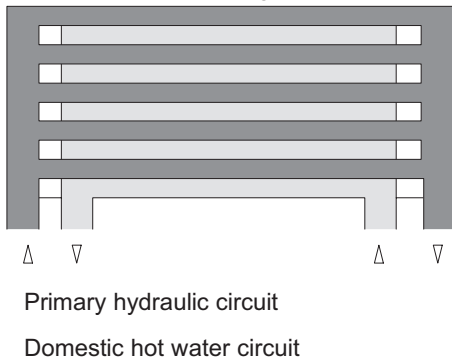

Figure 6.2

### 6.2 Removal



**Warning:** isolate the boiler from the mains electricity supply before removing any covering or component.

- 1 Remove the panels of the case.
- 2 Empty the primary circuit and the D.H.W. circuit of the boiler.
- 3 Remove the control panel following the instructions from 4 in section 2.3.
- 4 Remove main electronic p.c.b. box following the instructions from 5 in section 2.4.
- 5 Completely unscrew the Allen key screws "2" in Figure 6.3 which hold the exchanger to the groups.

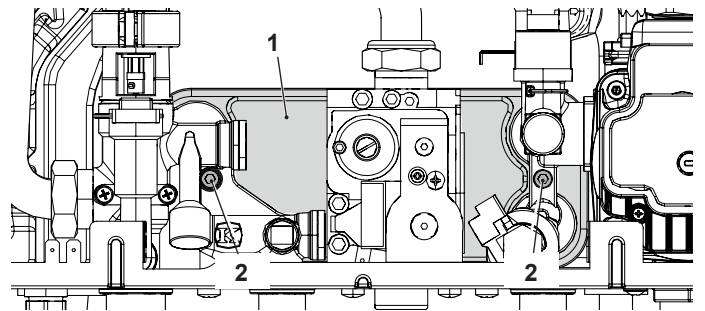

Figure 6.3

- 6 Move the exchanger towards the rear of the boiler and extract it to the left.

Reassemble the D.H.W. heat exchanger carrying out the removal operations in the reverse order.



**Warning:** to lubricate the O-ring gaskets exclusively use a silicone base grease compatible to be in contact with foods and approved by the local water Authorities.



**Warning:** When reassembling the exchanger be sure to put the off center location/securing pin indicated in Figure 6.4 towards the left side of the boiler.

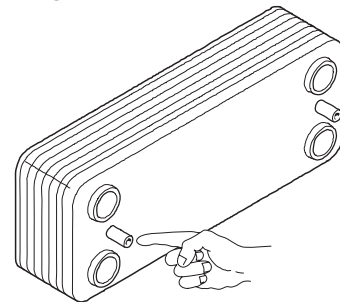

Figure 6.4



# PUMP

## 7 PUMP

### 7.1 Function

The pump "1" in Figure 7.1 and Figure 7.2 has the function of making the water in the main circuit circulate through the main condensing heat exchanger and therefore through the C.H. system (during the C.H. function) or through the secondary heat exchanger (during the D.H.W. function).

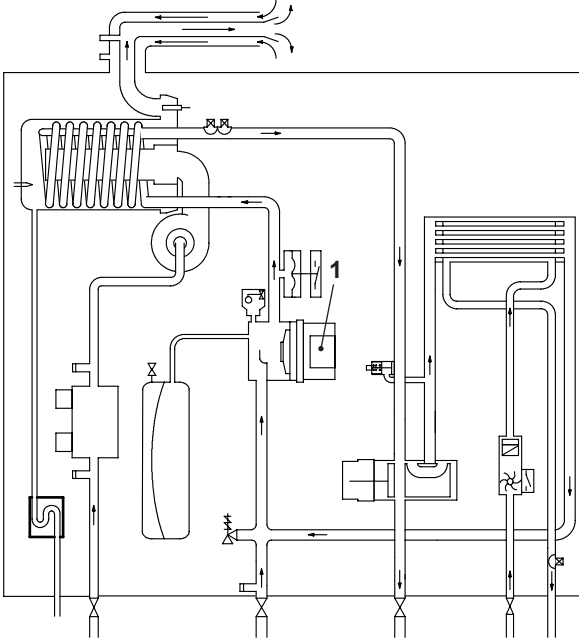

Figure 7.1



**Warning:** isolate the boiler from the mains electricity supply before removing any covering or component.

- ✓ Check that the pump is not seized and that the movement of the rotor is not subject to mechanical impediments.

With the boiler off, remove the front panel. Remove the air release plug of the pump and turn the rotor with a screwdriver.

- ✓ Check that the impeller is correctly connected to the rotor shaft and that the rotor moves freely.

With the boiler off remove the front and right hand side case panels, lower the control panel and empty the primary circuit. Remove the pump head by undoing the screws which hold it to the pump body and check that the impeller is firmly joined to the rotor.

### 7.2 Removal pump head



**Warning:** isolate the boiler from the mains electricity supply before removing any covering or component.

- 1 Remove the front case panel.
- 2 Empty the primary circuit of the boiler.
- 3 Disconnect the connector "2" (Figure 7.2).
- 4 Unscrew the four screws "3" and remove the pump head "1".

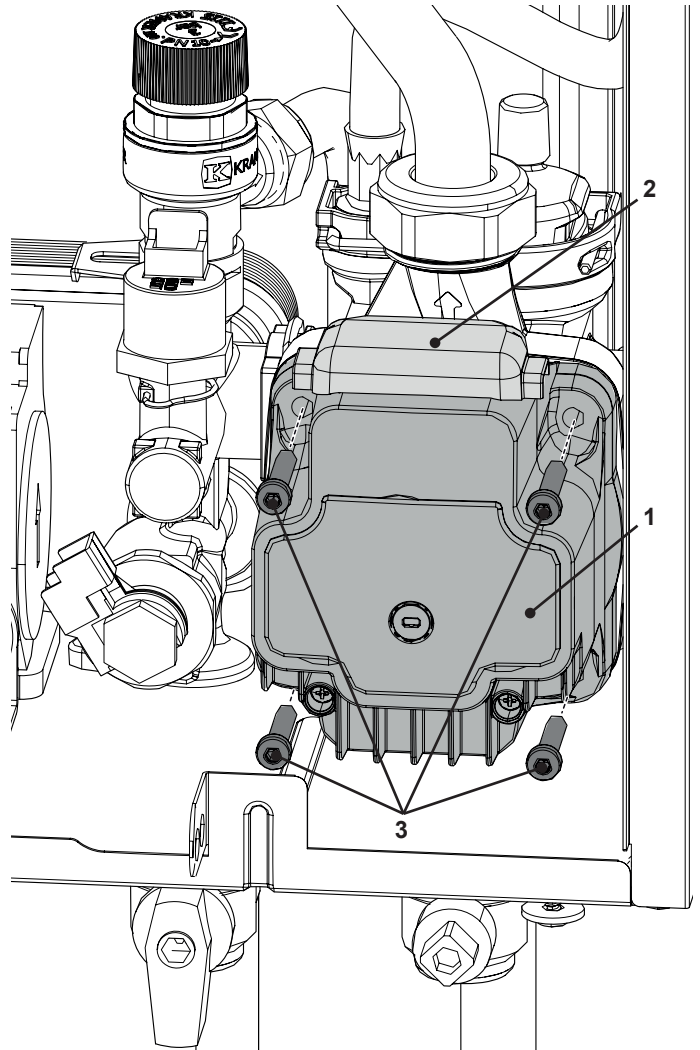

Figure 7.2

Reassemble the pump head carrying out the removal operations in the reverse order. When reassembling the pump head, check the correct position of the gasket and tighten the screws "3" proceeding diagonally around the pump.

# THREE WAY DIVERTER VALVE

## 8 THREE WAY DIVERTER VALVE

### 8.1 Function

The diverter valve "1" (Figure 8.1) has the function of modifying the hydraulic circuit of the boiler by means of an electric command given by the electronic control p.c.b. in order to send the water that exits the primary heat exchanger towards the C.H. system or towards the D.H.W. heat exchanger.

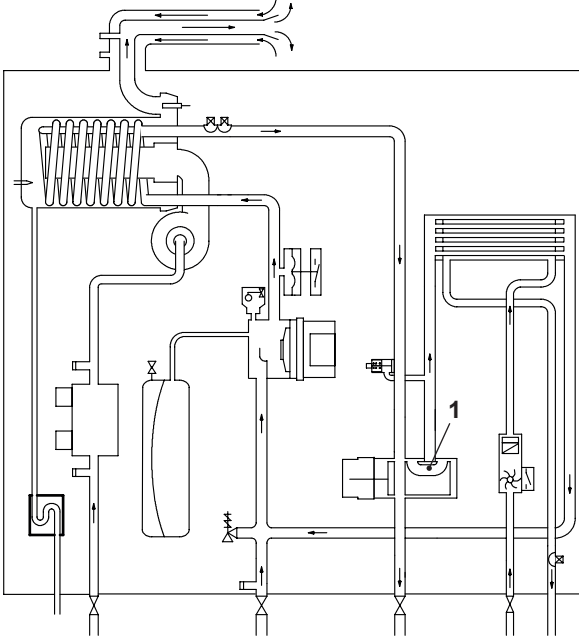

Figure 8.1

### 8.2 Checks



**Warning: check the electrical continuity.**

Figure 8.2 indicates the relationship between the electric command coming from the electronic control p.c.b. and the position of the actuator "2" (spindle) when the boiler operates in **D.H.W. mode**.

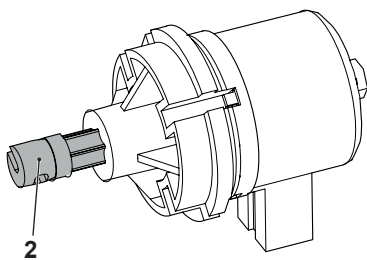

Spindle outside

Figure 8.2 D.H.W. mode

Figure 8.3 indicates the relationship between the electric command coming from the electronic control p.c.b. and the position of the actuator "2" (spindle) when the boiler operates in **C.H. mode**.

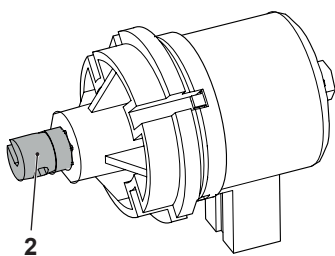

Spindle inside

Figure 8.3 C.H. mode

### 8.3 Removal of the electric actuator



**Warning: isolate the boiler from the mains electricity supply before removing any covering or component.**

- 1 Remove the front case panel.
- 2 Disconnect the connectors "3" (Figure 8.4).
- 3 Remove fastener "4" and remove the actuator "5".

Reassemble the actuator carrying out the removal operations in the reverse order.

When reassembling the actuator, refer to Figure 8.3 or to the wiring diagram in section "3 Diagrams" on page 8 for the correct wiring connection.



**Warning: Please note the electric actuator is energized 240VAC even if the boiler is in a standby condition.**

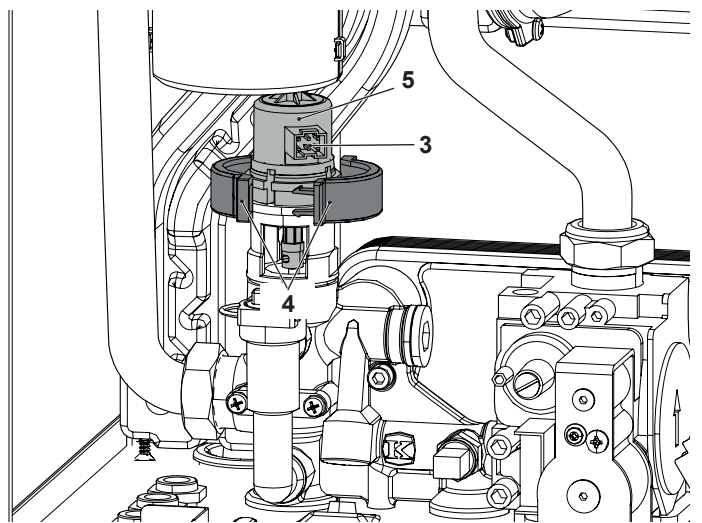

Figure 8.4

### 8.4 Removal of the three way diverter valve

- 1 Remove the front and both side case panels.
- 2 Empty the primary circuit and the D.H.W. circuit of the boiler.
- 3 Remove the electric actuator (see "8.3 Removal of the electric actuator" on page 18).
- 4 Unscrew the three way diverter valve "6" Figure 8.5.

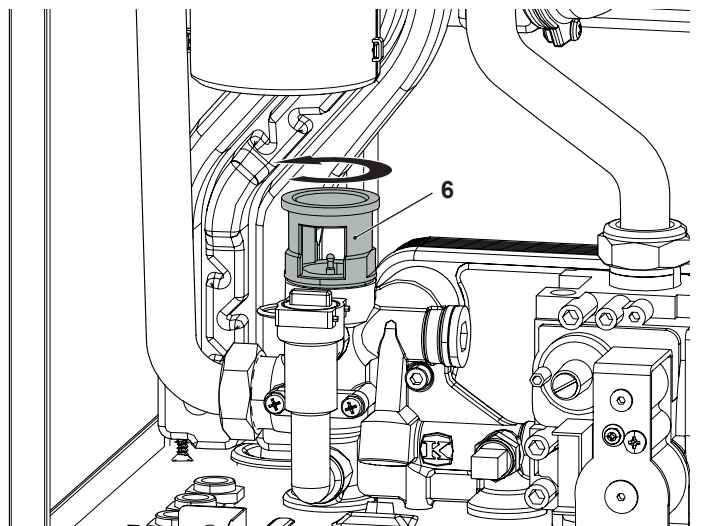



Figure 8.5

Reassemble the three way diverter valve carrying out the removal operations in the reverse order.

## THREE WAY DIVERTER VALVE

 **Warning:** to lubricate the O-ring gaskets exclusively use a silicone base grease compatible to be in contact with foods and approved by the local water Authorities.

### 8.5 Removal of the diverter group

- 1 Remove the front and both side case panels.
- 2 Empty the primary circuit and the D.H.W. circuit of the boiler.
- 3 Remove the electric actuator (section "8.3 Removal of the electric actuator" on page 18).
- 4 Disconnect D.H.W. temperature probe NTC "7" (Figure 8.6).
- 5 Unscrew the connector "8" (Figure 8.6), the C.H. flow connector and the D.H.W. outlet connector.
- 6 Remove the D.H.W. heat exchanger (see "6.2 Removal" on page 16).
- 7 Unscrew the screws "9" and remove the diverter group.

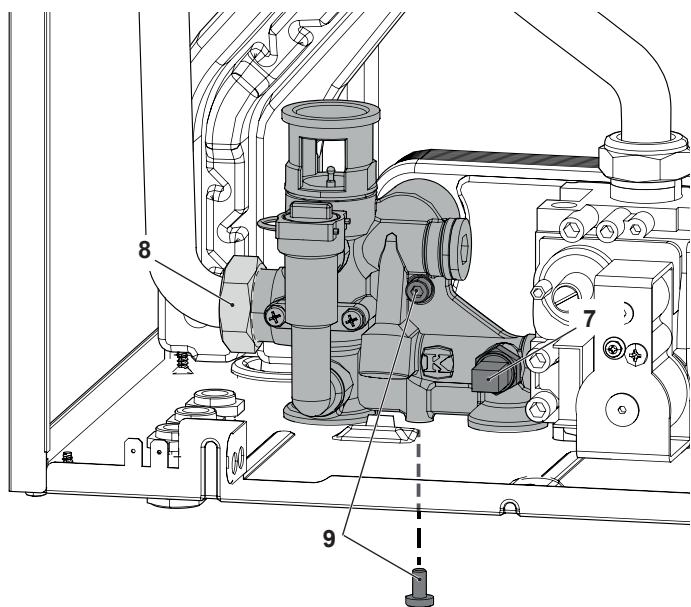



Figure 8.6

- 8 Reassemble the diverter group carrying out the removal operations in the reverse order.

 **Warning:** to lubricate the O-ring gaskets exclusively use a silicone base grease compatible to be in contact with foods and approved by the local water Authorities.

# MAIN ELECTRONIC CONTROL/IGNITION P.C.B.

## 9 MAIN ELECTRONIC CONTROL/IGNITION P.C.B.

### 9.1 Function

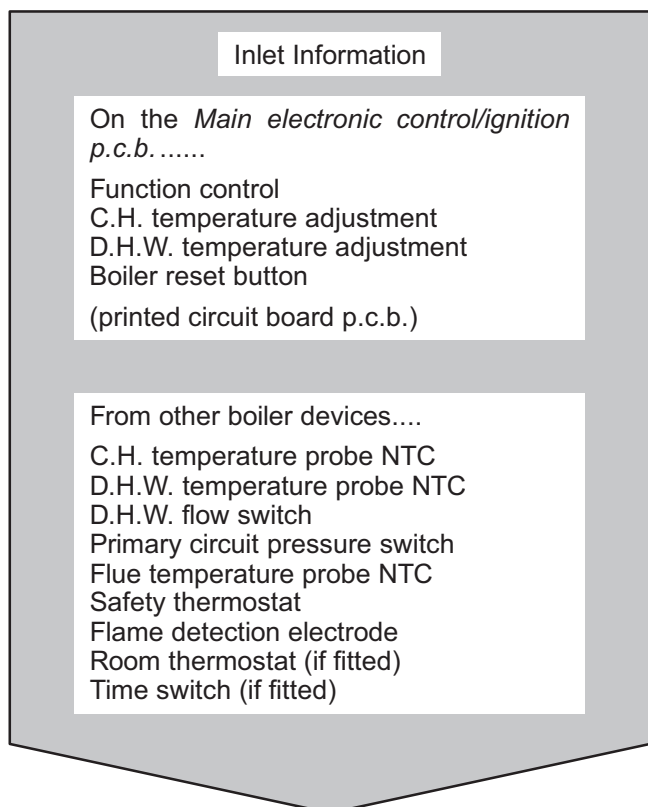

#### Inlet Information

On the *Main electronic control/ignition p.c.b.*.....

Function control  
C.H. temperature adjustment  
D.H.W. temperature adjustment  
Boiler reset button  
(printed circuit board p.c.b.)

From other boiler devices....

C.H. temperature probe NTC  
D.H.W. temperature probe NTC  
D.H.W. flow switch  
Primary circuit pressure switch  
Flue temperature probe NTC  
Safety thermostat  
Flame detection electrode  
Room thermostat (if fitted)  
Time switch (if fitted)

#### Outlet command

Pump  
Three way diverter valve  
Gas valve  
Fan  
Ignition electrodes  
Display indicates "E"\*  
\*control panel electronic p.c.b.

The fundamental function of the *Main electronic control/ignition p.c.b.* is that of controlling the boiler in relation to the external needs (i.e. heating the dwelling or heating the water for D.H.W. use) and operating in order to keep the temperature of the hydraulic circuits constant.

This is obviously possible within the useful power and maximum working temperature limits foreseen.

Generally, the *Main electronic control/ignition p.c.b.* receives inlet information coming from the boiler (the sensors) or from the outside (printed circuit board p.c.b., room thermostat, etc.), processes it and consequently acts with outlet commands on other components of the boiler (Figure 9.1).

The *Main electronic control/ignition p.c.b.* is also a full sequence ignition device and does a sequence of operations (ignition cycle) which lead to the ignition of the gas at the burner.

It checks the presence of the flame during the entire period in which it is activated and supplies the fan regulating its speed.

The *Main electronic control/ignition p.c.b.* has a safety function and any incorrect interventions or tampering can result in conditions of dangerous functioning of the boiler.

The *Main electronic control/ignition p.c.b.* can lock the functioning of the boiler (lock state) and stop its functioning up to the resetting intervention. The lock-out is signalled on the display of the printed circuit board p.c.b. and can be reset only by using the boiler reset button placed on the control panel electronic p.c.b. (see section "10.1 Function" on page 28).

Some components which are connected to the device can activate the lock state. The causes of a lock state could be:

- The intervention of the safety thermostat (overheat of the primary circuit).
- The intervention of the flue temperature probe (overheat of the combustion products).
- A fault on gas supply.
- Faulty ignition (faulty ignition electrodes, their wiring or connection).
- Faulty flame detection (faulty detection electrode, its wiring or connection).
- Faulty condensate drainage.
- Faulty gas valve (faulty on-off operators or not electrically supplied).
- Faulty *Main electronic control/ignition p.c.b.*

Other components like the primary circuit pressure switch can temporarily stop the ignition of the burner but allow its ignition when the cause of the intervention has stopped.

Figure 9.24 and Figure 9.25 show the sequence of the operations that are carried out at the start of every ignition cycle and during normal functioning.

Figure 9.1

# MAIN ELECTRONIC CONTROL/IGNITION P.C.B.

## 9.2 Selection and adjustment devices

On the *Main electronic control/ignition p.c.b.* several selection, adjustment and protection devices are located. (Figure 9.2).

Some of these devices are directly accessible by the user (function control, temperature adjustment etc.) others, like the fuses, are accessible by removing the main electronic p.c.b. lid.

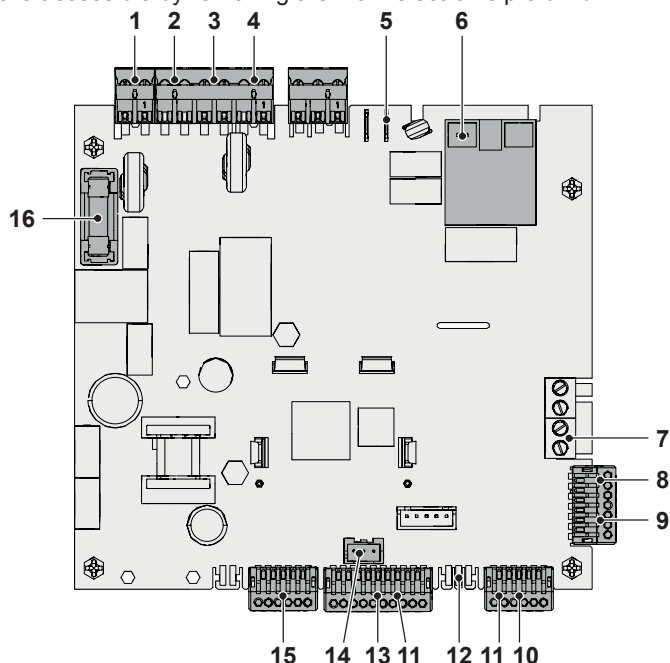

**Figure 9.2**

- 1 Connector - electric supply p.c.b.
- 2 Connector - fan
- 3 Connector - pump
- 4 Connector - gas valve
- 5 Connector - ground reference for ignition / detection electrode
- 6 Connector - ignition / detection electrode
- 7 Connector - external temperature probe and remote control (optional)
- 8 Connector - controller pump
- 9 Connector - controller fan
- 10 Connector - D.H.W. outlet temperature probe NTC
- 11 Connector - safety thermostat and C.H. temperature probe NTC
- 12 Connector - primary circuit pressure switch
- 13 Connector - safety thermal fuse
- 14 Connector - D.H.W. flow switch
- 15 Connector - 3 way diverter valve
- 16 Fuse F1 3,15 AF

## 9.3 Checking the temperature

The *Main electronic control/ignition p.c.b.* makes it possible to separately adjust the C.H. water flow temperature and D.H.W. outlet temperature.

The temperature of the water is converted into an electric signal by means of temperature probes.

The user, setting the desired temperature with the control panel p.c.b. key  $\Delta$    $\nabla$  or  $\Delta$    $\nabla$ .

If the power requested is lower than 40% of the maximum power output then control is achieved by switching ON the burner at minimum power, then switching OFF (ON/OFF function). If the power requested is higher, then the burner is switched ON at maximum power and will control by modulating to 40% of the maximum power output.

During the C.H. operation (Figure 9.3), the signal coming from the C.H. temperature probe is compared to the signal given by the control panel through the adjustment made by the user (key  $\Delta$    $\nabla$ ). The result of such a comparison operates the fan speed thus regulating the gas flow rate and consequently changing the useful output of the boiler.

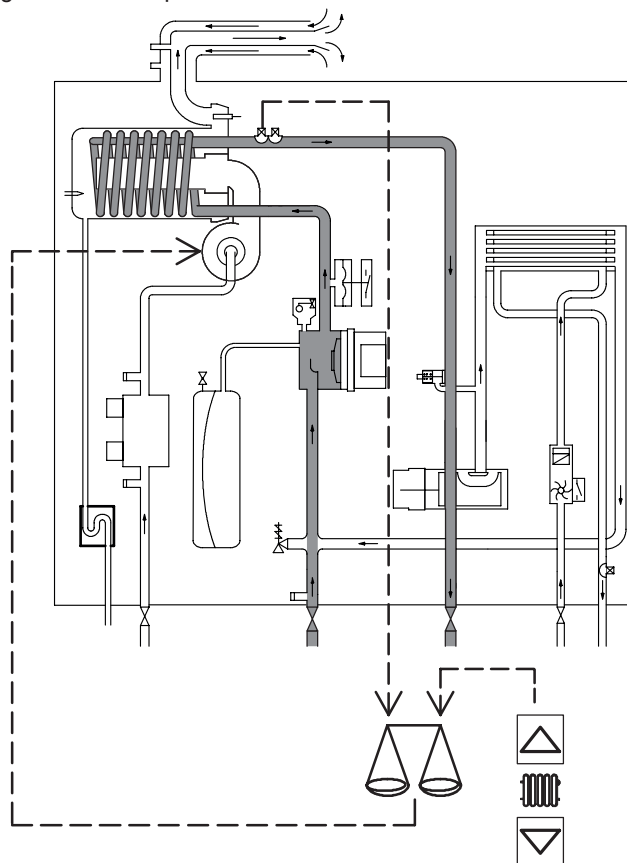

**Figure 9.3**

## MAIN ELECTRONIC CONTROL/IGNITION P.C.B.

When the boiler functions in D.H.W. (Figure 9.4), the signal coming from the D.H.W. temperature probe is compared with the signal given by the control panel through the adjustment made by the user (key  $\triangle$   $\square$   $\nabla$ ).

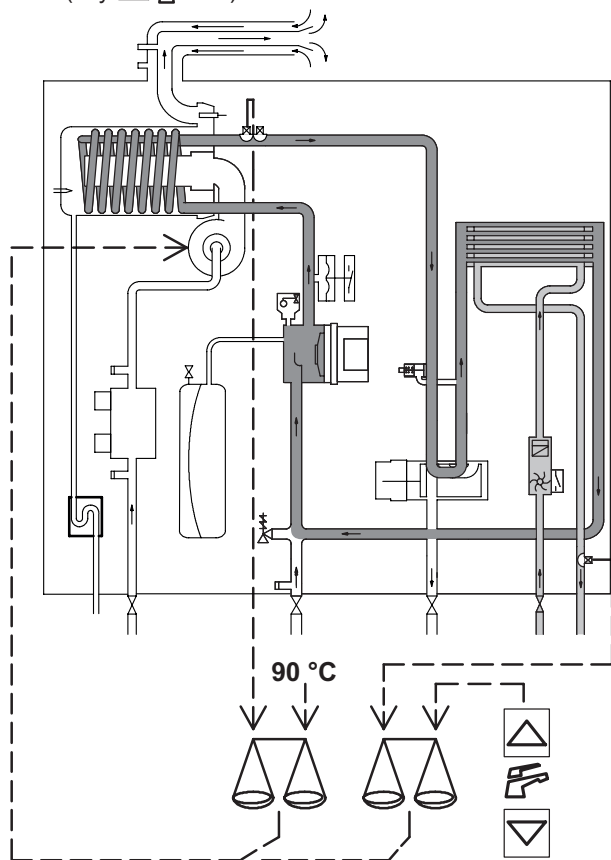

Figure 9.4

Normally, the result of the comparison between these two signals directly operates the fan speed adjusting the useful output generated in order to stabilize the temperature of the exiting water. If during the D.H.W. mode operation, the temperature of the primary circuit goes over 90°C, the useful output is automatically reduced so that the primary circuit cannot reach excessive temperatures.

The control sequences in function  $\square$  and  $\square$  in function are illustrated in detail in sections "9.7 Thermal control in the  $\square$  mode" on page 26 and "9.8 Thermal control in the  $\square$  mode" on page 27.

### 9.4 Setting the boiler control function modes

It is possible to select the various boiler control function modes hereafter named "parameters" by using the keys of the control panel p.c.b.

1 To enter in the parameters setting mode press at the same time the 2 keys "F" and "G" (Figure 9.5) and hold in for 5 second until the display shows Figure 9.6.

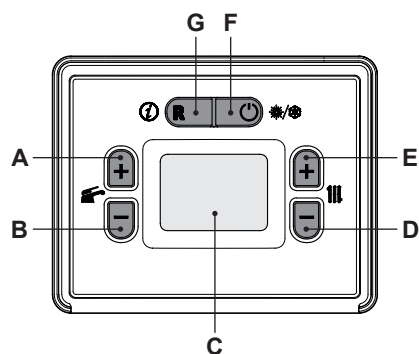

Figure 9.5



Figure 9.6

2 Scroll the various menus using keys "A" or "B" (Figure 9.5) until the LCD display indicates the letters **Cod**, indicating entry into "parameter Cod" (Figure 9.7), and then displays three dashes " - - -".



Figure 9.7

3 To enter the selected menu:

- Press the "E" button to set "2 - -", then press "A" to confirm the 2 and go to the next segment.
  - Press the "E" button to set "2 7 -", then press "A" to confirm the 7 and go to the next segment.
  - Press the "E" button to set "2 7 5", then press "A" to confirm the 5 and go back to the list of parameters.
- The code **P10** appears on the display, indicating entry into "parameter P10" (Figure 9.8).

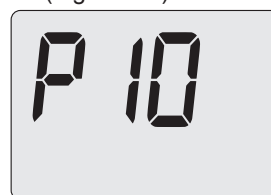

Figure 9.8

4 By using buttons "D" or "E" (Figure 9.5) it is possible to modify the value of parameter P10 (Figure 9.9).

- 03 = M275V.2024 SM
- 04 = M275V.2428 SM
- 05 = M275V.2832 SM

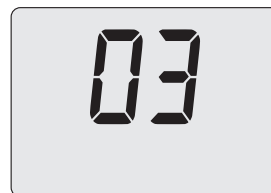

Figure 9.9

## MAIN ELECTRONIC CONTROL/IGNITION P.C.B.

5 Press "A" or "B" (Figure 9.5) to confirm the value entered and return to the list of parameters (Figure 9.8).

6 Press "A" or "B" until the LCD display shows the code **P02**, indicating entry into "parameter P02" (Figure 9.10).



Figure 9.10

7 By using buttons "D" or "E" (Figure 9.5) it is possible to modify the value of parameter P02 (Figure 9.11).

78 = Default

83 = Correct



Figure 9.11

8 Press "A" and hold until the LCD display shows the code **P09**, indicating entry into "parameter P09" (Figure 9.12).



Figure 9.12

9 By using buttons "D" or "E" (Figure 9.5) it is possible to modify the value of parameter P09 (Figure 9.13).

03 = Default

01 = Correct



Figure 9.13

10 Press "A" or "B" (Figure 9.5) to confirm the value entered and return to the list of parameters (Figure 9.12).

11 Press "A" and hold until the LCD display shows the code **A01**, indicating entry into "parameter A01" (Figure 9.14).



Figure 9.14

12 By using buttons "D" or "E" (Figure 9.5) it is possible to modify the value of parameter A01 (Figure 9.15).

00 = Natural gas (G20)

01 = Propane gas - LPG (G31)

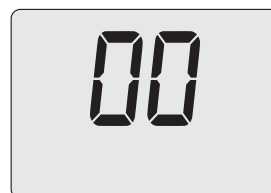

Figure 9.15

13 Press "A" or "B" (Figure 9.5) to confirm the value entered and return to the list of parameters (Figure 9.14).

14 Press "A" and hold until the LCD display shows the code **A02**, indicating entry into "parameter A02" (Figure 9.16).



Figure 9.16

15 By using buttons "D" or "E" (Figure 9.5) it is possible to modify the value of parameter A02.

01 = high temperature (50/80°C)

02 = low temperature (25/55°C)

03 = full temperature set (25/85°C) (factory setting)

16 Press "A" or "B" (Figure 9.5) to confirm the value entered and return to the list of parameters (Figure 9.16).

17 Press "A" and hold until the LCD display shows the code **A12**, indicating entry into "parameter A12" (Figure 9.17).



Figure 9.17

18 By using buttons "D" or "E" (Figure 9.5) it is possible to modify the value of parameter A12 (Figure 9.18).

03 = Default

04 = Correct



Figure 9.18

19 Press "A" (Figure 9.5) to confirm the value entered and return to the list of parameters (Figure 9.17).

20 Press "A" and hold until the LCD display shows the code **A21**, indicating entry into "parameter A21" (Figure 9.19).

# MAIN ELECTRONIC CONTROL/IGNITION P.C.B.



Figure 9.19

21 By using buttons "D" or "E" (Figure 9.5) it is possible to modify the value of parameter A21 (Figure 9.20).

- 00 = Room thermostat
- 01 = Remote control



Figure 9.20

22 Press "A" (Figure 9.5) to confirm the value entered and return to the list of parameters (Figure 9.19).

23 Press "A" and hold until the LCD display shows the code A38, indicating entry into "parameter A38" (Figure 9.21).



Figure 9.21

24 By using buttons "D" or "E" (Figure 9.5) it is possible to modify the value of parameter A38 (Figure 9.22).

- 60 = Default
- 10 = Correct



Figure 9.22

25 Press "A" or "B" (Figure 9.5) to confirm the value entered and return to the list of parameters (Figure 9.21).

26 Press "F" (Figure 9.5) to exit "programming mode".

**Important: at the end of the setting operation it is important to fill/update the table in the installation manual see chapter COMMISSIONING section: Setting record.**

## 9.5 Checks

✓ Check that the fuses are complete

If the Main electronic control/ignition p.c.b. does not supply any device (pump, fan, etc.) check that the fuses 16 (Figure 9.2) are complete.

If a fuse has blown replace it with one that has the same characteristics after having identified the reason for failure.

✓ Lock sequence

Start the boiler until the burner is ignited.

With the burner firing, interrupt the gas supply. The Main electronic control/ignition p.c.b. must carry out four complete ignition cycles and then, after about 4 minutes, goes to lock-out state.

Switch off and on the electricity supply to the boiler, by means of the fused spur isolation switch, the device must not unlock and the burner must not turn on.

## 9.6 Removal of the electronic control p.c.b



**Warning: isolate the boiler from the mains electricity supply before removing any covering or component.**

When replacing the Main electronic control/ignition p.c.b. all parameters must be correctly checked / adjusted accordingly with the values noted in table in the installation manual see chapter COMMISSIONING section: Setting record (for information on parameters see also section "9.4 Setting the boiler control function modes" on page 22).

- 1 Remove all the body panels (see section "2.2 Case panels" on page 5).
- 2 Gain access to the parts located inside the Main electronic p.c.b. box as explained in the section "2.4 Main electronic p.c.b. box" on page 6 of this manual.
- 3 Unscrew the screws "1" (Figure 9.23).
- 4 Remove all the wiring connected to the *Main electronic control/ignition p.c.b.*
- 5 Remove the *Main electronic control/ignition p.c.b.*

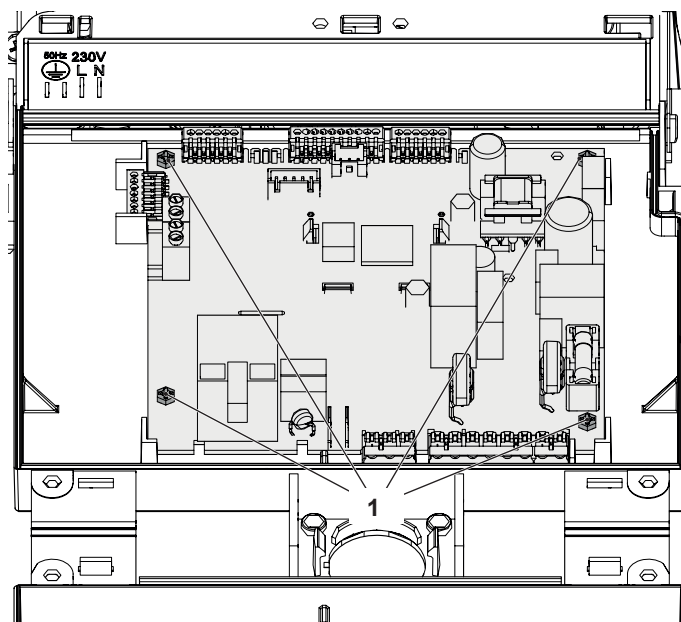

Figure 9.23

- 6 Re-assemble the *Main electronic control/ignition p.c.b.* following the removal procedures in the reverse order.

### Important

When re-assembling the *Main electronic control/ignition p.c.b.*:

- 7 It is not necessary to utilise static protections but it is advisable to ensure that the p.c.b. is handled with care and held at the edges and with clean dry hands.

### Attention

After installing the *Main electronic control/ignition p.c.b.* properly set the parameters.



---

## MAIN ELECTRONIC CONTROL/IGNITION P.C.B.

---



**Warning:** After cleaning or replacement as detailed above, it is deemed necessary to undertake a combustion analysis as detailed in section "11.3 Adjustment - Chimney Sweep Function" on page 30.

# MAIN ELECTRONIC CONTROL/IGNITION P.C.B.

## 9.7 Thermal control in the mode

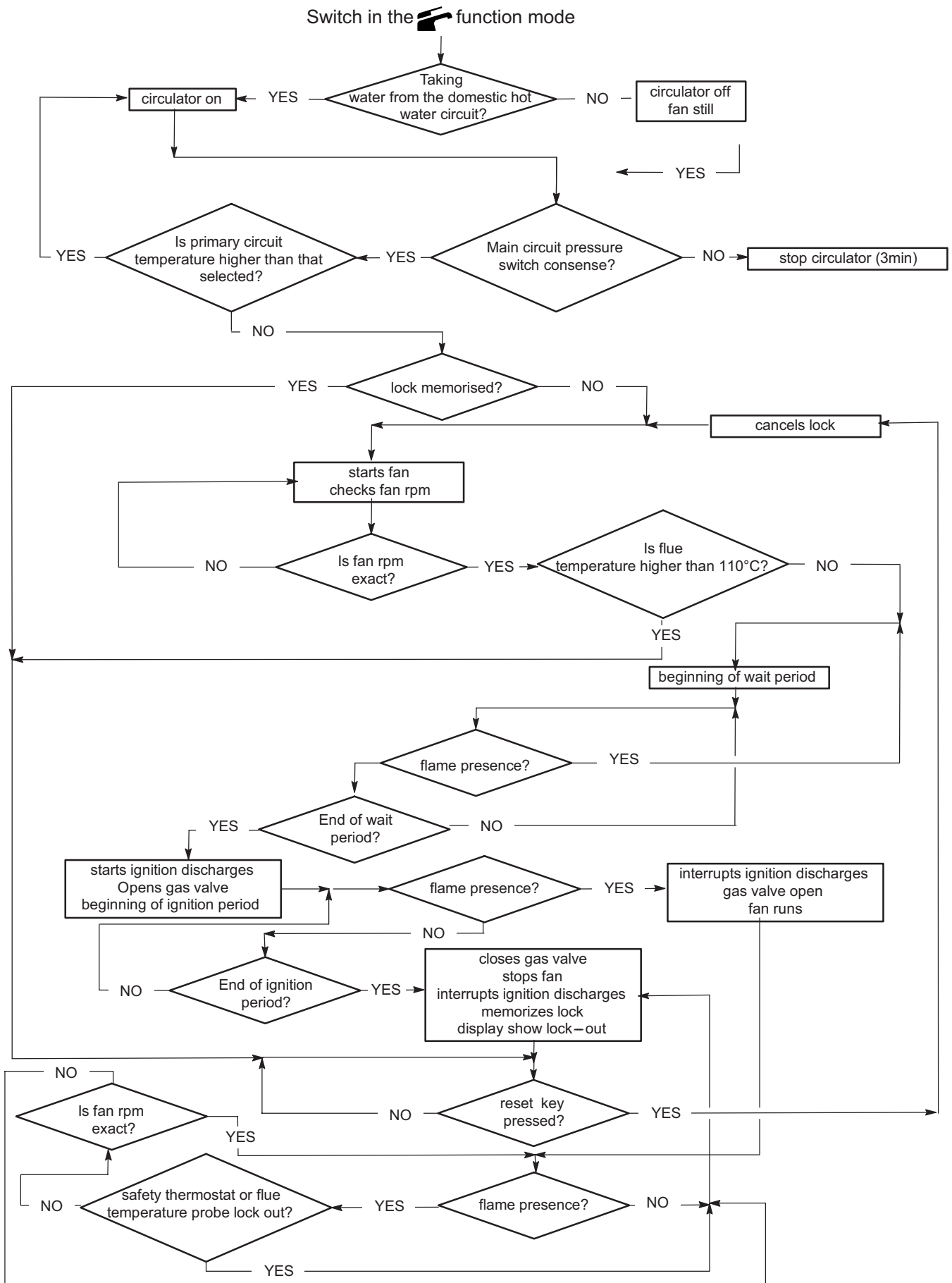

Figure 9.24

# MAIN ELECTRONIC CONTROL/IGNITION P.C.B.

## 9.8 Thermal control in the III mode

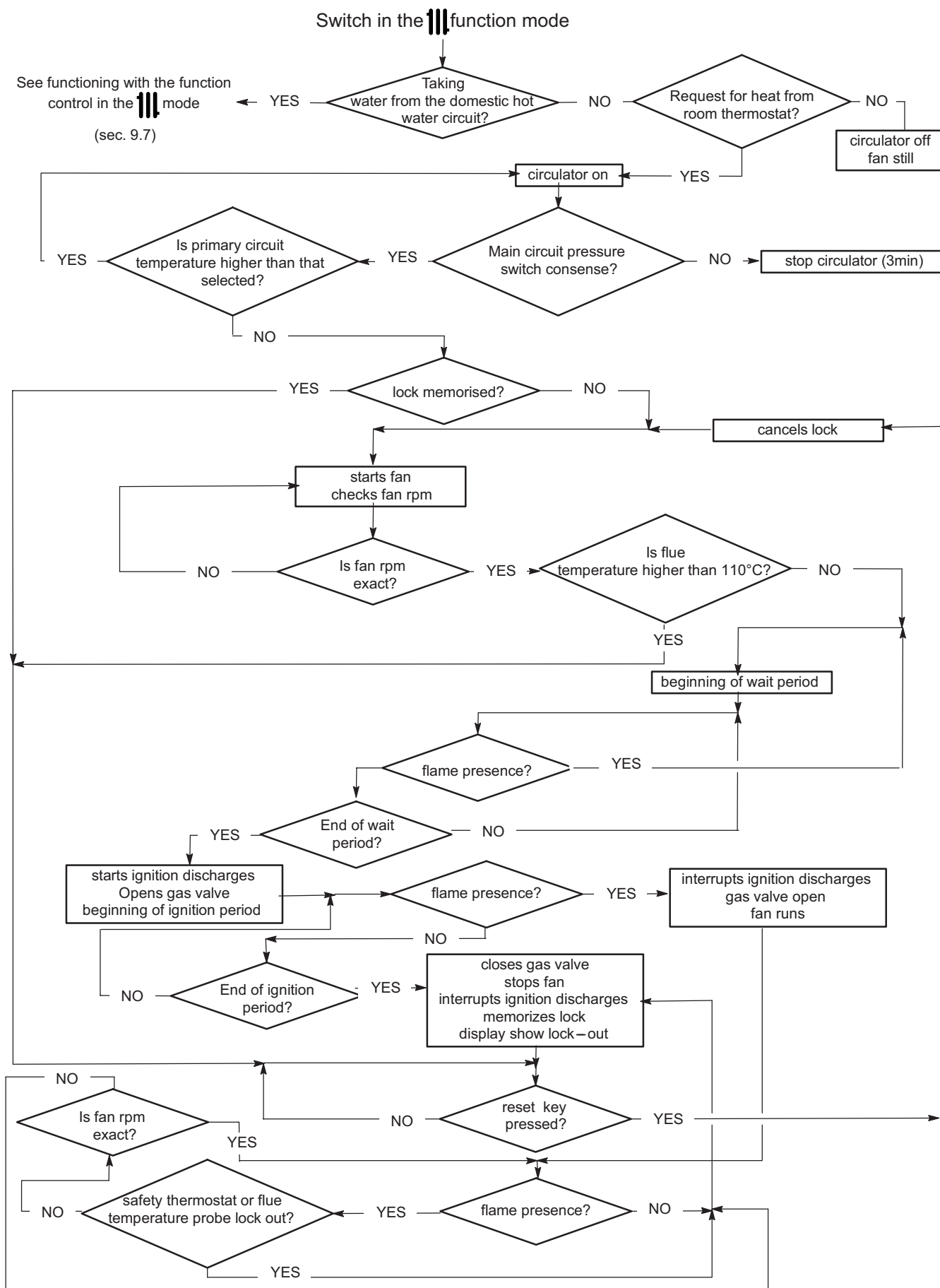

Figure 9.25

# CONTROL PANEL ELECTRONIC P.C.B.

## 10 CONTROL PANEL ELECTRONIC P.C.B.

### 10.1 Function

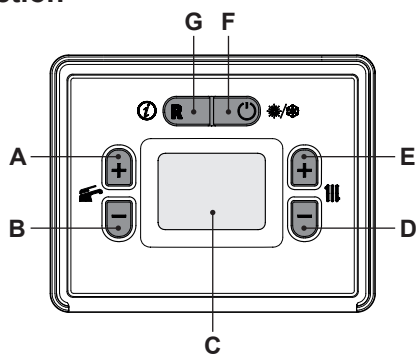

Figure 10.1

- A D.H.W. temperature increase key
- B D.H.W. temperature reduce key
- C Display
- D C.H. temperature reduce key
- E C.H. temperature increase key
- F Stand-by/Winter/Summer key
- G Reset

The Control panel electronic p.c.b. can give to the service 3 levels of informations:

- Normally information
- Info modality
- Function modes setting modality

### 10.2 Normally information

#### KEY











	The symbol indicates a volatile error. The boiler is reactivated automatically once the fault has been resolved
	The symbol indicates that the boiler can be restarted directly by the user by pressing the reset button
	Next maintenance period expiring. Enter the "INFO mode" to view the remaining weeks before maintenance is due
	All symbols with lines radiating from them indicate that the symbol is flashing

#### SIGNAL DISPLAYED BY THE LCD

LCD	FUNCTION
<b>E01 + RESET</b>	Safety lockout due to failed ignition
<b>E02 + RESET</b>	Lockout due to safety thermostat
<b>E03 + RESET</b>	EEPROM error
<b>E04 + !</b>	Pump circulation failure or insufficient system pressure
<b>E05 + !</b>	Fan control anomaly

LCD	FUNCTION
<b>E06 + !</b>	Heating NTC probe failure
<b>E07 + !</b>	DHW NTC probe failure
<b>E08 + !</b>	External NTC probe failure
<b>E09 + !</b>	Flue gas NTC probe failure (interruption)
<b>E10 + !</b>	Lockout due to tripping of the flue gas probe
<b>E11 + !</b>	Parasite flame
<b>E12 + !</b>	Return NTC probe failure
<b>E13 + !</b>	Central Heating pressure high
<b>E14 + !</b>	Temperature gradient circulation failure (>2K/s)
<b>E22 + RESET</b>	Heating delivery temperature between 90°C and 100°C
<b>E25 + !</b>	Boiler in antifreeze
<b>E26 + RESET</b>	Gas valve fault
<b>E28 + !</b>	Tank NTC probe failure
<b>E50 + !</b>	Communication with remote control lost
<b>E52 + RESET</b>	Maximum number of remote unlock attempts
<b>E54 + RESET</b>	Filling function of C.H. water completed, but pressure is lower than the minimum pressure for boiler filling
<b>E58 + RESET</b>	Filling function of C.H. water completed, but pressure is higher than the maximum pressure for boiler filling
	Next maintenance period expiring. Enter the "INFO mode" to view the remaining weeks before maintenance is due
	Boiler off, (antifreeze protection active)
	Boiler in winter (heating/DHW) and stand-by
	Boiler in summer (DHW only) and stand-by
	Boiler with DHW power request. The DHW temperature is displayed.
	Boiler with heating power request. The temperature of the primary heating circuit is displayed.
	Burner ignition (discharge)

## CONTROL PANEL ELECTRONIC P.C.B.

LCD	FUNCTION
	Flame detected (burner ignited)
	Boiler in DHW anti-freeze phase (the  symbol flashes)
	Boiler in heating anti-freeze phase (the  symbol flashes)
	Heating set temperature (all other symbols are disabled)
	DHW set temperature (all other symbols are disabled)
	Boiler in chimney sweep function. To activate the chimney sweep function, set "parameter P06≠0". 1 = minimum power 2 = maximum power  During the chimney sweep function, the  and/or  symbols do not flash.

## 11 GAS VALVE

### 11.1 Function

The gas valve "1" in Figure 11.1 controls the gas inflow to the boiler burner.

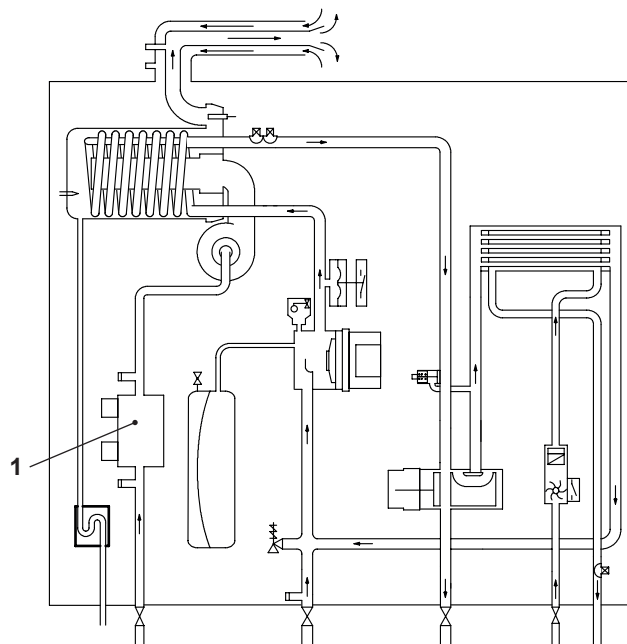

Figure 11.1

By means of an electric command given to the on-off operators the passage of the gas through the Gas valve can be opened or closed.

### 11.2 Description of the parts

(Figure 11.2)

- 2 On-off operators electric connector
- 3 Gas valve inlet pressure test point
- 4 On-off operators
- 5 Minimum boiler power adjustment
- 6 Maximum boiler power adjustment

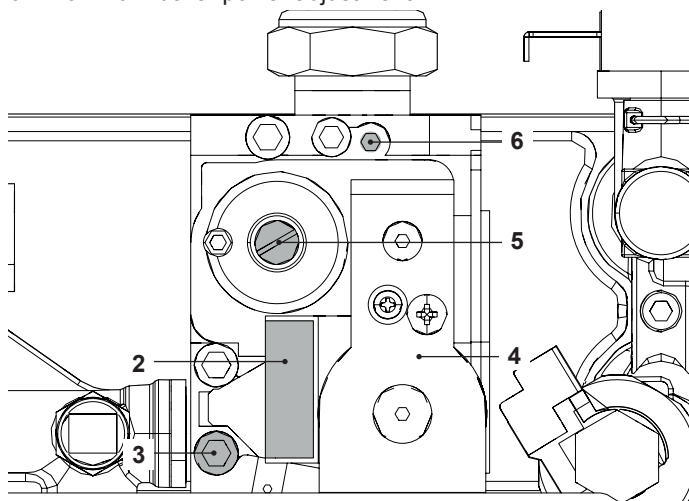

Figure 11.2

### 11.3 Adjustment - Chimney Sweep Function



**Warning:** isolate the boiler from the mains electricity supply before removing any covering or component.



Each time after measuring the gas pressure, fully close all tapping points that were used. After each gas adjustment, the valve adjustment components must be sealed.



**Warning:** risk of electrocution. The boiler is live during the operations described in this section. Never touch any electrical parts.

**Check the supply pressure before making any adjustment to the gas valve.**

- 1 Close the gas inlet valve.
- 2 Remove the front panel of the case and lower the control panel (see sections "2.2 Case panels" on page 5 and "2.3 Control panel" on page 5).
- 3 Loosen the internal screw on the Inlet Pressure Test Point "3" (Figure 11.2) of the Gas valve and connect a pressure gauge using a suitable hose.
- 4 Open the gas inlet valve.
- 5 Read the inlet pressure value and ensure that it is within the limits given in the table *Gas supply pressures*, of the user/installation manual. If it does not comply with the required pressure check the gas supply line and governor for faults and/or correct adjustment.
- 6 Switch off the boiler **close the gas inlet valve**.
- 7 Disconnect the pressure gauge and close the Inlet Pressure Test Point "3" (Figure 11.2).

#### Gas valve adjustment



The person carrying out a combustion measurement should have been assessed as competent in the use of a flue gas analyser and the interpretation of the results. The flue gas analyser used should be one meeting the requirements of BS7927 or BS-EN50379-3 and be calibrated in accordance with the analyser manufacturers' requirements, and have a current calibration certificate.

- 8 Fit the probe of the flue analyser in the flue exhaust sampling point located on the exhaust pipes of the boiler (Figure 11.3).

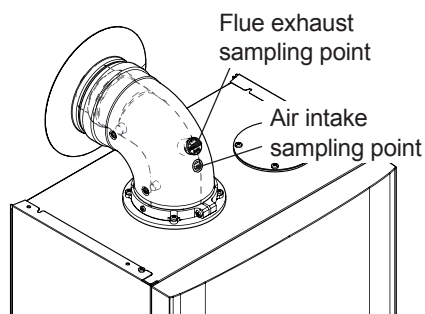

Figure 11.3

- 9 Turn on the boiler, switching on the fused spur isolation switch.
- 10 Open the gas inlet valve.
- 11 Turn on the boiler and operate for 2 minutes to pre-heat the flue, before commencing any adjustments.
- 12 Make sure that the room thermostat is in the "heat request" position.

## GAS VALVE

13 Open at least one hot water tap fully.

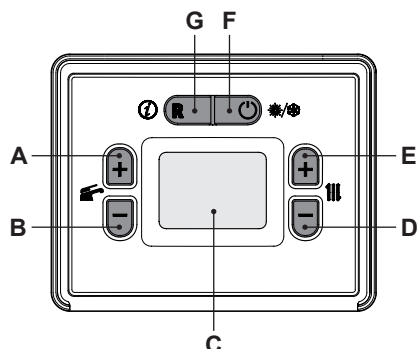

Figure 11.4

14 To enter in the “programming mode” press at the same time the 2 keys “F” and “G” (Figure 11.4) and hold in for 5 second until the code **P00** appears on the display, indicating entry into “parameter P00” (Figure 11.5).



Figure 11.5

15 Scroll the various parameters using keys “A” or “B” (Figure 11.4) until the LCD display shows the code **P06**, indicating entry into “parameter P06” (Figure 11.6).



Figure 11.6

16 Press key “E” (Figure 11.4) to show the value of parameter P06 on the LCD display (Figure 11.7).



Figure 11.7

17 Press E and the LCD display shows the number **01**, indicating activation of the “chimney sweep function” at minimum output (Figure 11.8).

18 Press A (Figure 11.4) to confirm the value entered and activate the function.



Figure 11.8

19 Press F (Figure 11.4) to exit “programming mode” (Figure 11.9).

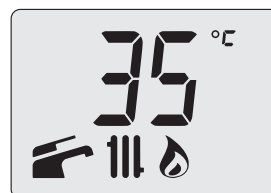

Figure 11.9

20 Allow the analyser to give a stable reading.

21 Read the CO<sub>2</sub> % value. It should be between:

Model BASICA	Type gas	CO <sub>2</sub> % value (range)
COND 24C	Natural (G20)	8,2 - 8,8
COND 28C		
COND 32C	Propane (G31)	9,4 - 10,0



**If the boiler starts up as expected, it is already within the limits indicated; move on to checking the maximum pressure.**

**Otherwise, follow the instructions below.**

22 To calibrate the boiler CO<sub>2</sub> (gas pressure at the burner) unscrew the protective brass cap “5” completely and turn the underlying Ø 4 mm hex head socket screw Figure 11.2. Turn it clockwise to increase the CO<sub>2</sub>.

### Checking the maximum gas valve setting

23 To enter in the “programming mode” press at the same time the 2 keys “F” and “G” (Figure 11.4) and hold in for 5 second until the code **P00** appears on the display, indicating entry into “parameter P00” (Figure 11.10).



Figure 11.10

24 Scroll the various parameters using keys “A” or “B” (Figure 11.4) until the LCD display shows the code **P06**, indicating entry into “parameter P06” (Figure 11.11).



Figure 11.11

25 Press key “E” (Figure 11.4) to show the value of parameter P06 on the LCD display (Figure 11.12).

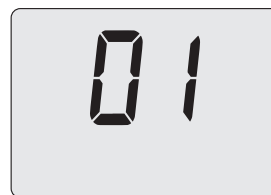

Figure 11.12

26 Press E and the LCD display shows the number **02**, indicating activation of the “chimney sweep function” at maximum DHW output (Figure 11.13).

27 Press A (Figure 11.4) to confirm the value entered and activate the function.

## GAS VALVE

vate the function.



Figure 11.13

28 Press F (Figure 11.4) to exit "programming mode" (Figure 11.14).



Figure 11.14

29 Allow the analyser to give a stable reading.  
30 Read the CO<sub>2</sub> % value. It should be between:

Model BASICA	Type gas	CO <sub>2</sub> % value (range)
COND 24C COND 28C COND 32C	Natural (G20)	9,0 - 9,6
	Propane (G31)	10,2 - 10,8

If the two values do not coincide, turn the RQ maximum adjustment screw (6 in Figure 11.2) for the gas valve and calibrate the CO<sub>2</sub> to the same value specified in the table above.

**!** After setting the CO<sub>2</sub> to the maximum (CO<sub>2</sub> at Q.nom.), CO<sub>2</sub> at the minimum (CO<sub>2</sub> at Q.min.) must be checked.

31 To exit the chimney sweeper, reset parameter P06 to 00 or wait 15 minutes with the boiler off (OFF).

32 Close the domestic hot water cocks.

33 Turn the boiler off by pressing "F" (Figure 11.4) until the message OFF appears on the LCD display (Figure 11.15).



Figure 11.15

**Important:** after the gas pressure checks and any adjustment operations, all of the test points must be sealed.

### 11.4 Checks

**!** **Warning:** isolate the boiler from the mains electricity supply before removing any covering or component.

✓ Check the on-off operators coils

- 1 Remove the front panel of the case.
- 2 Disconnect the electrical connector "2" (Figure 11.2).
- 3 Measure the electrical resistance between the connector pins of the on-off operators as illustrated in Figure 11.16.

Upper on-off operator  
approx. 6400 Ω\*

Lower on-off operator  
approx. 920 Ω\*

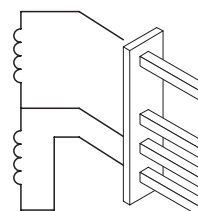

\*at ambient temperature.

Figure 11.16

### 11.5 Removal of the gas valve

**!** **Warning:** isolate the boiler from the mains electricity supply before removing any covering or component.

- 1 Remove the front panel of the case as explained in the section "2.3 Control panel" on page 5, of this manual.
- 2 Disconnect the connector "8" (Figure 11.17), see also connector "2" (Figure 11.2).

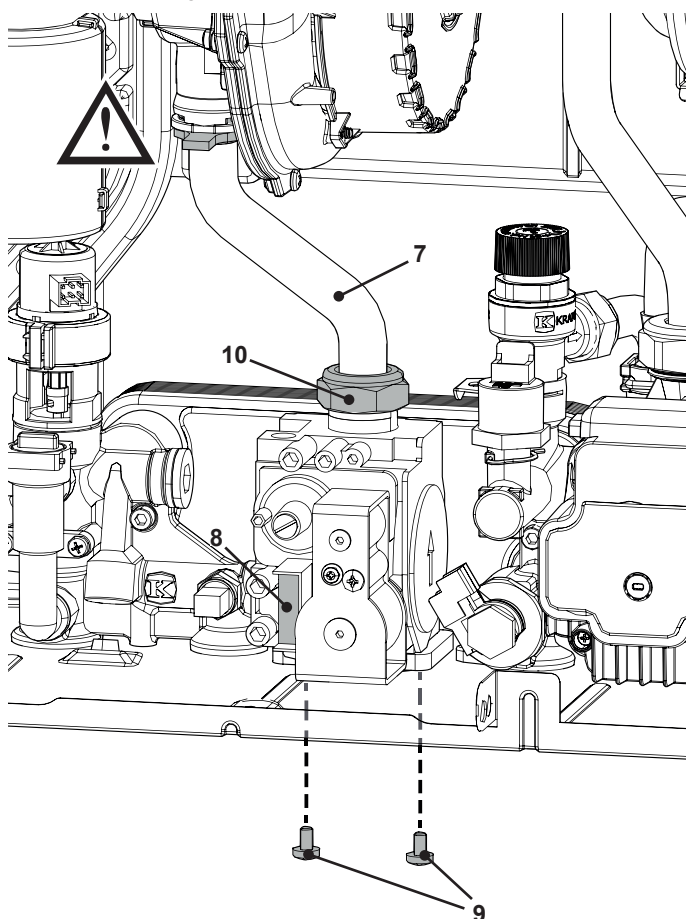

Figure 11.17

- 3 Turn off the gas supply and disconnect the gas isolation cock connector from the inlet port of the gas valve.
- 4 Unscrew the connector "10" (Figure 11.17) and remove the pipe "7".
- 5 Unscrew the screws "9" and remove the valve (Figure 11.17).
- 6 Reassemble the valve carrying out the removal operations in reverse order.

**!** **Warning:** Be careful not to damage the OR gasket of the gas pipe when inserting the pipe in the air box (air/gas mixer).

Before fitting a new valve, it is advisable to preset it as fol-



---

## GAS VALVE

---

**lows.**

- 7 Remove the brass plug and turn the plastic screw inside it fully clockwise until it stops. Do not overtight.
- 8 Turn it counter-clockwise 2 and 3/4 turns.
- 9 Adjust the gas valve using the flue analyser as described in section "11.3 Adjustment - Chimney Sweep Function" on page 30.

**After any service operation on the components of the gas circuit check all the connections for gas leaks.**



**Warning:** After cleaning or replacement as detailed above, it is deemed necessary to undertake a combustion analysis as detailed in section "11.3 Adjustment - Chimney Sweep Function" on page 30.

# PRIMARY CIRCUIT FLOW SWITCH

## 12 PRIMARY CIRCUIT PRESSURE SWITCH

### 12.1 Function

The Primary circuit pressure switch ("1" in Figure 12.1) function is to check the presence of water in the primary hydraulic circuit and that the pressure is above the minimum.

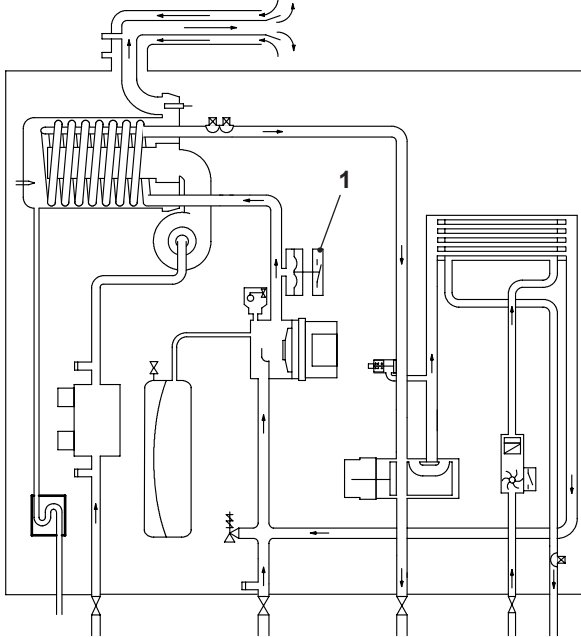

Figure 12.1

This device is connected to the main electronic control p.c.b. and if, it does not activate the control board will indicate that a fault condition (see section "4.1 Display diagnostic" on page 12 of this manual) has occurred.

### 12.2 Removal



**Warning:** isolate the boiler from the mains electricity supply before removing any covering or component.

- 1 Remove the front and right hand side panels of the case, turn off the flow and return isolation valves and empty the primary circuit.
- 2 Remove the fixing spring "3" (Figure 12.2) and remove the primary circuit pressure switch "4".
- 3 Disconnect the connector "2" (Figure 12.2).

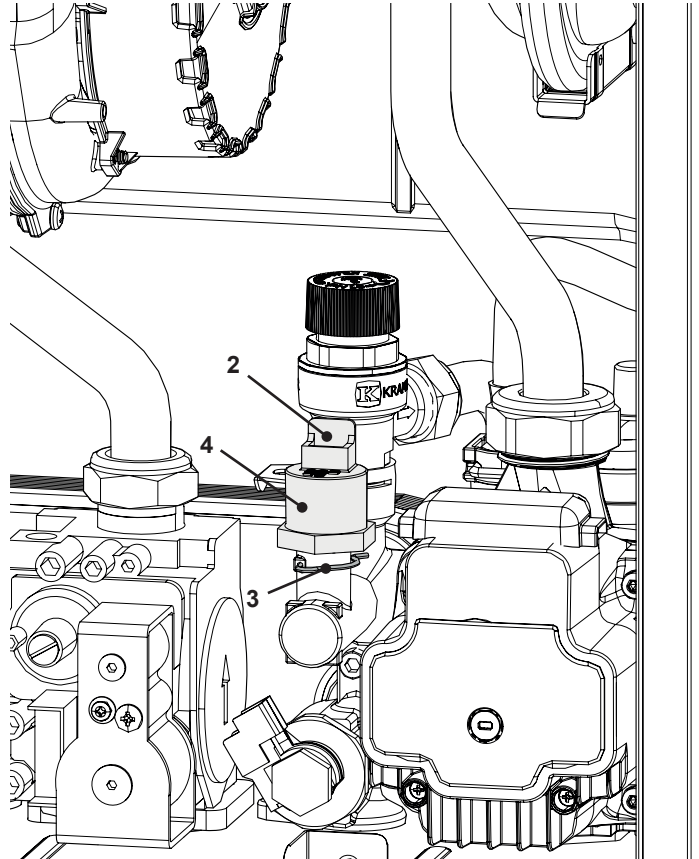

Figure 12.2

- 4 Reassemble the primary circuit pressure switch in reverse order of removal.



**Warning:** to lubricate the O-ring gaskets exclusively use a silicone base grease compatible to be in contact with foods and approved by the local water Authorities.

# EXPANSION VESSEL AND PRESSURE GAUGE

## 13 EXPANSION VESSEL AND PRESSURE GAUGE

### 13.1 Function

The Expansion vessel ("1" in Figure 13.1) function is to allow for the volume expansion of the C.H. circuit water due to the temperature rise.

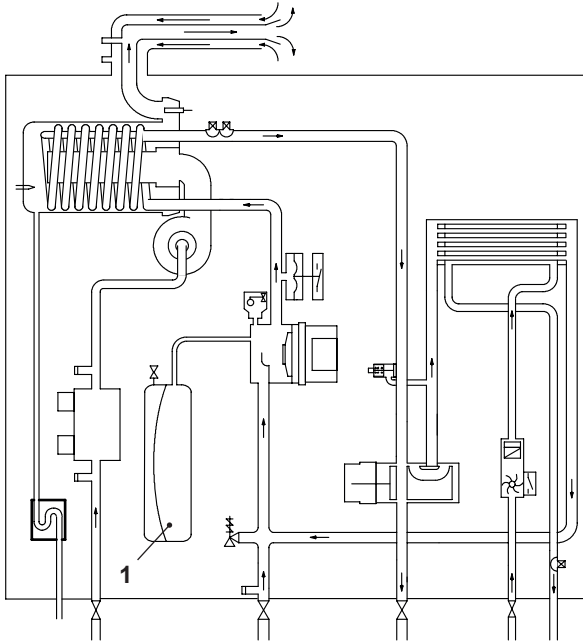

Figure 13.1

### 13.2 Checks

- 1 Turn off the flow and return isolation valves and empty the primary circuit of the boiler.
- 2 Remove the protective cap "2" in Figure 13.2 from the valve on the top of the expansion vessel and connect a suitable air pressure gauge.

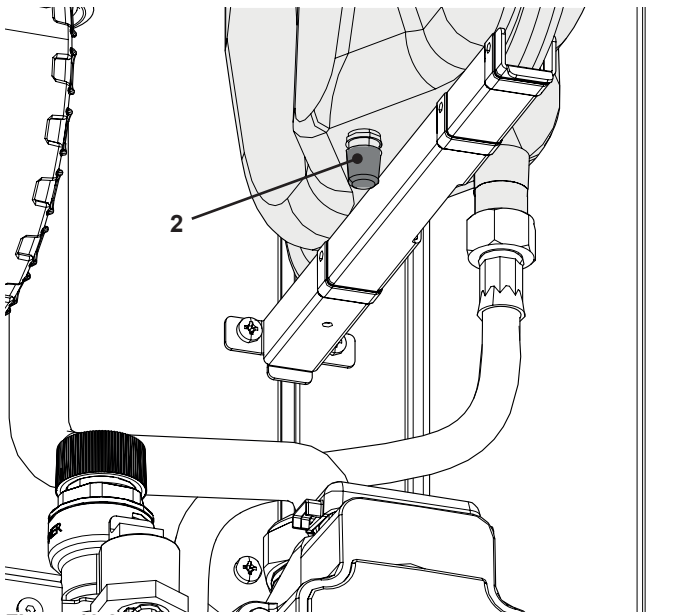

Figure 13.2

- 3 Check the pre-load pressure and refer to the section *Expansion vessel* in the *User manual and installation instructions* for the correct value.

### 13.3 Removal of the expansion vessel



Warning: isolate the boiler from the mains electricity supply before removing any covering or component.

- 1 Remove the front and right hand side panels of the case, turn off the flow and return isolation valves and empty the primary circuit.
- 2 Completely unscrew the connection "5" (Figure 13.3).
- 3 Unscrew the screws "4" and "3" (Figure 13.3).
- 4 Remove the expansion vessel from the front of the boiler.

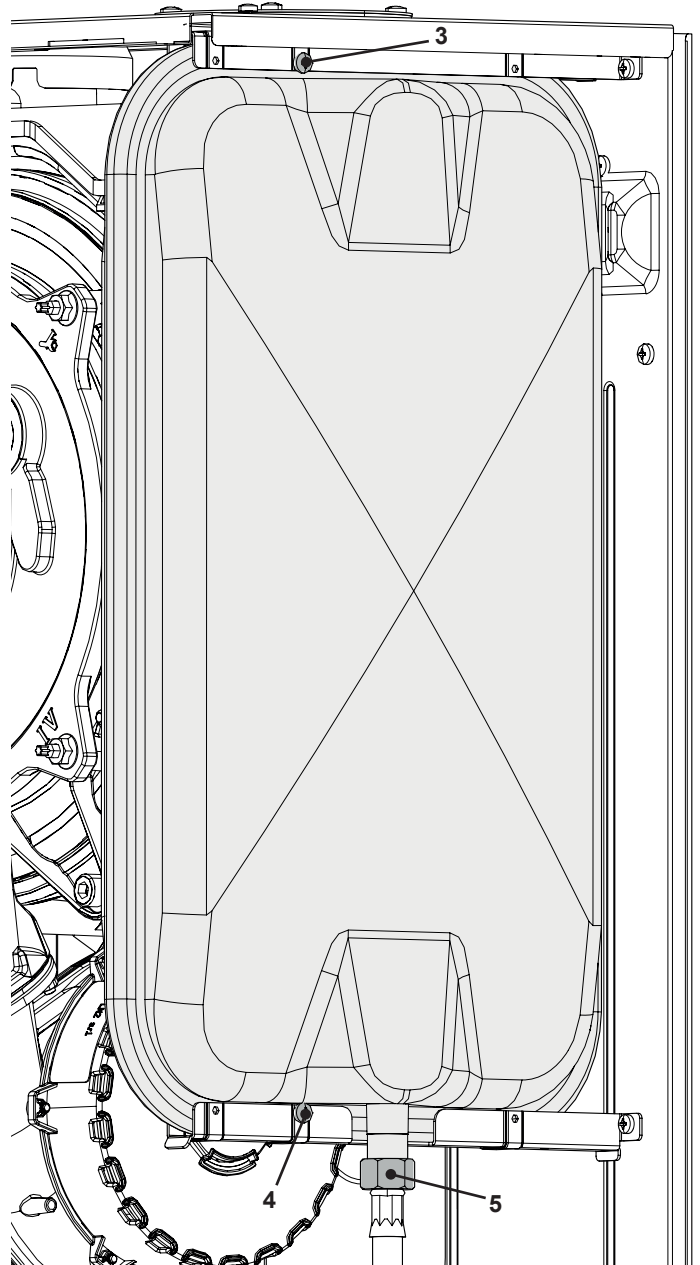

Figure 13.3

- 5 Re-assemble the parts in reverse order of removal.

# D.H.W. FLOW SWITCH, FILTER AND FLOW LIMITER

## 14 D.H.W. FLOW SWITCH, FILTER AND FLOW LIMITER

### 14.1 Function

The D.H.W. flow switch "1" in Figure 14.1 is a device that generates an electrical signal when hot water is drawn.

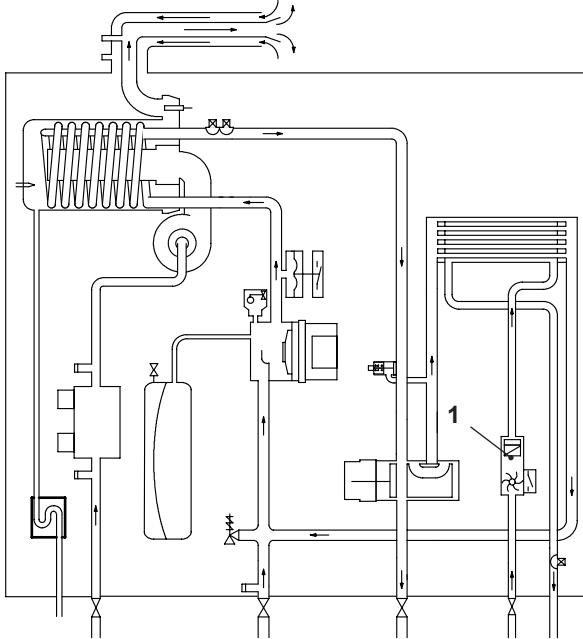

Figure 14.1

When the flow rate through the D.H.W. circuit reaches about 2,5 litres/min', the sensor closes the electric contact that switches the boiler D.H.W. operation ON.

### 14.2 Description and location of parts - (Figure 14.2 - Figure 14.3)

The flow limiter is inserted inside the delivery connection of the D.H.W. heat exchanger.

- 2 Flow switch plug
- 3 Body with flow meter turbine
- 4 O-ring
- 5 Sensor
- 6 Filter

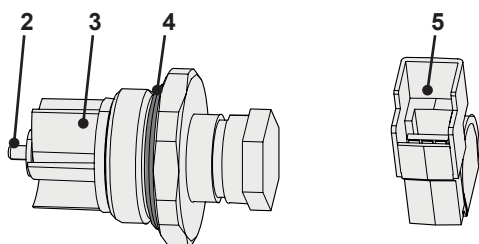

Figure 14.2

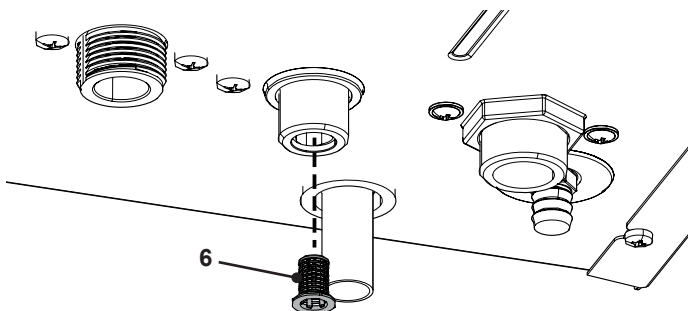

Figure 14.3

### 14.3 Removal of the sensor



**Warning:** isolate the boiler from the mains electricity supply before removing any covering or component.

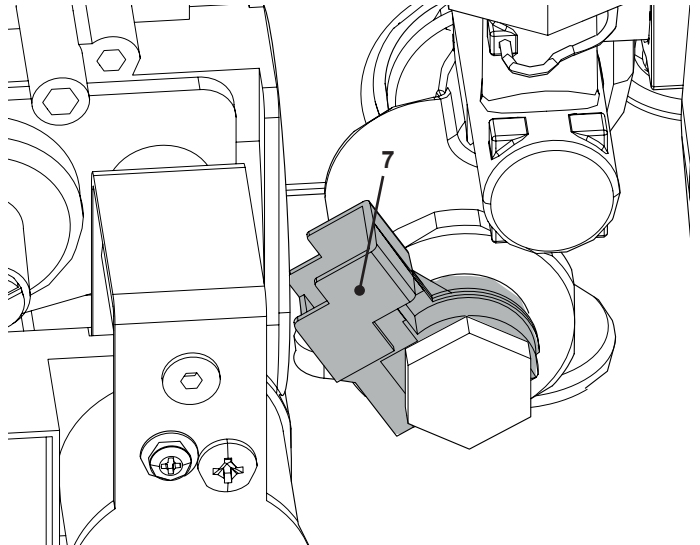

Figure 14.4

- 1 Remove the front panel of the case.
- 2 Remove the sensor holder "7" (Figure 14.4) and disconnect the connectors "8" (Figure 14.5).
- 3 Remove the sensor.

### 14.4 Checks



**Warning:** isolate the boiler from the mains electricity supply before removing any covering or component.

✓ Sensor operation

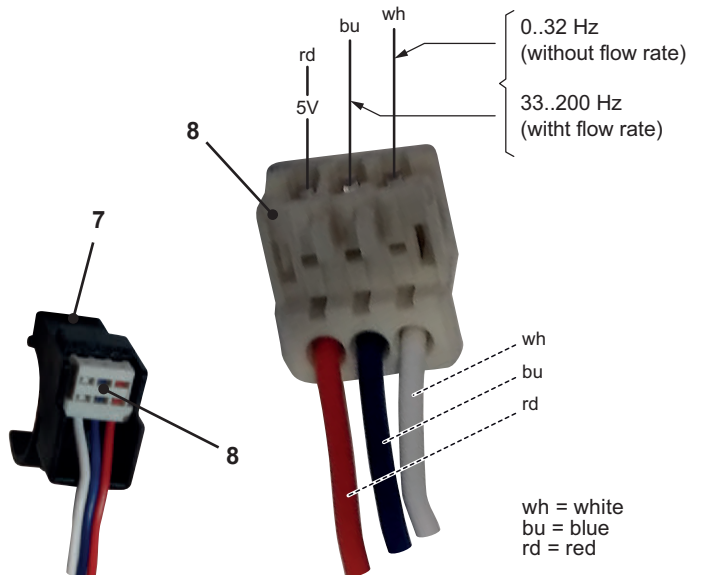

Figure 14.5

- 1 Remove the front panel of the case.
- 2 Don't disconnect the connectors "8".
- 3 Measure the electrical frequency at the leads of the sensor. Without flow rate the electrical frequency must be 0±32Hz. With flow rate the electrical frequency must be 33±200Hz.

---

## D.H.W. FLOW SWITCH, FILTER AND FLOW LIMITER

---

### 14.5 Removal of the flow switch group and D.H.W. circuit filter



**Warning:** isolate the boiler from the mains electricity supply before removing any covering or component.

- 1 Please remove the sensor first as previously described and ensure it remains dry.
- 2 Remove the front panel of the case and empty the D.H.W. circuit.
- 3 Remove the sensor holder "10" and unscrew the flow switch plug "9" (Figure 14.6).

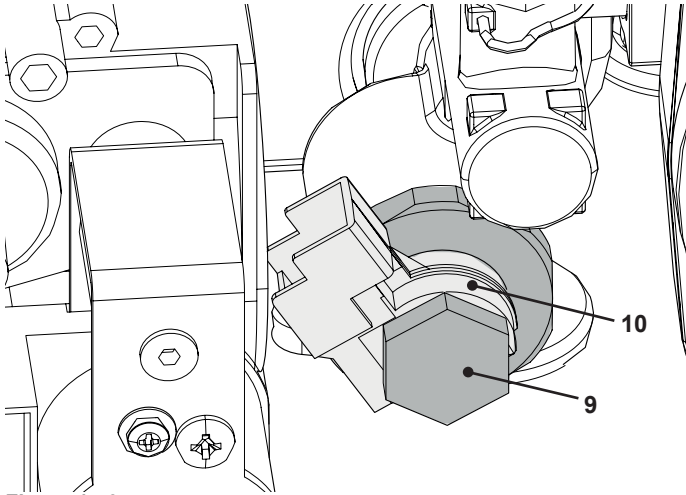

Figure 14.6

- 4 Check that body with flow meter turbine "3" (Figure 14.2) rotates freely.
- 5 Reassemble the parts following the removing sequence in reverse order.

# TEMPERATURE PROBE

## 15 NTC HEATING DELIVERY PROBE - NTC MAXIMUM TEMPERATURE AND D.H.W. TEMPERATURE PROBE NTC

### 15.1 Function

The NTC probe has the function of converting the temperature of the water in the hydraulic circuit where it is installed into an electrical signal (resistance).

The relation between temperature and electrical resistance is stated in Figure 15.1.

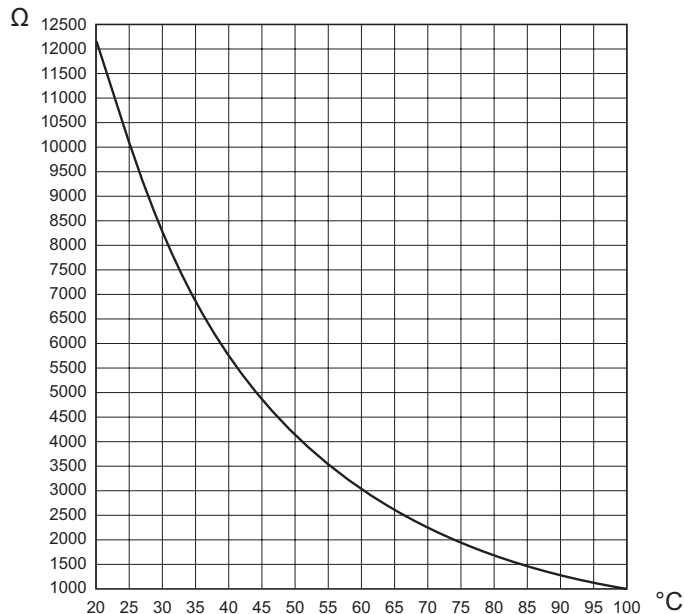

Figure 15.1

On the boiler there are two temperature probes. One on the output of the primary condensing heat exchanger (NTC heating delivery probe - NTC maximum temperature) "1" in Figure 15.2 and Figure 15.3 and one on the output of the D.H.W. heat exchanger (D.H.W. temperature probe NTC) "2" in Figure 15.2 and Figure 15.4.

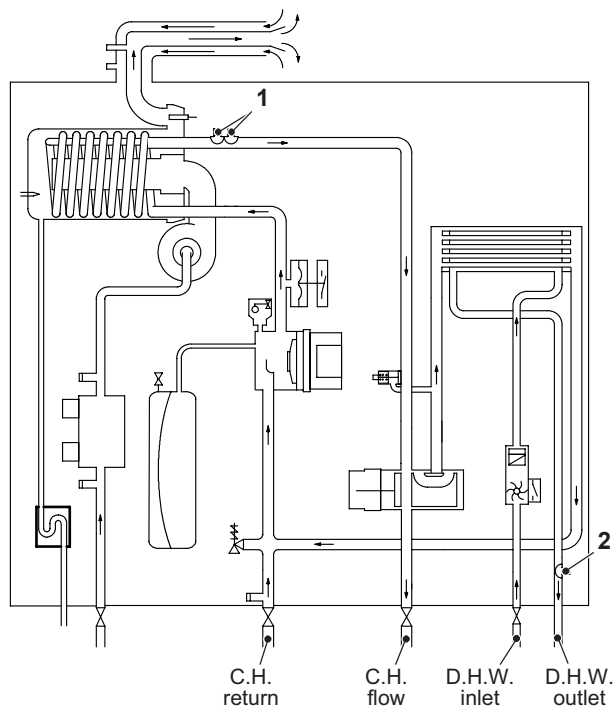

Figure 15.2

### 15.2 Checks

- ✓ Temperature-resistance relationship



**Warning:** isolate the boiler from the mains electricity supply before removing any covering or component.

Disconnect the cable from the Temperature probe. Measure the temperature of the pipe "3" (only NTC heating delivery probe - NTC maximum temperature) where the Temperature probe is located and check the electrical resistance according to the graph in Figure 15.1.

### 15.3 Removal of the NTC heating delivery probe - NTC maximum temperature



**Warning:** isolate the boiler from the mains electricity supply before removing any covering or component.

- 1 Remove all the case panels and the sealed chamber lid.
- 2 Remove the electric connector "4" and the NTC probe "1" (Figure 15.3).
- 3 Reassemble the NTC probe carrying out the removal operations in reverse order.

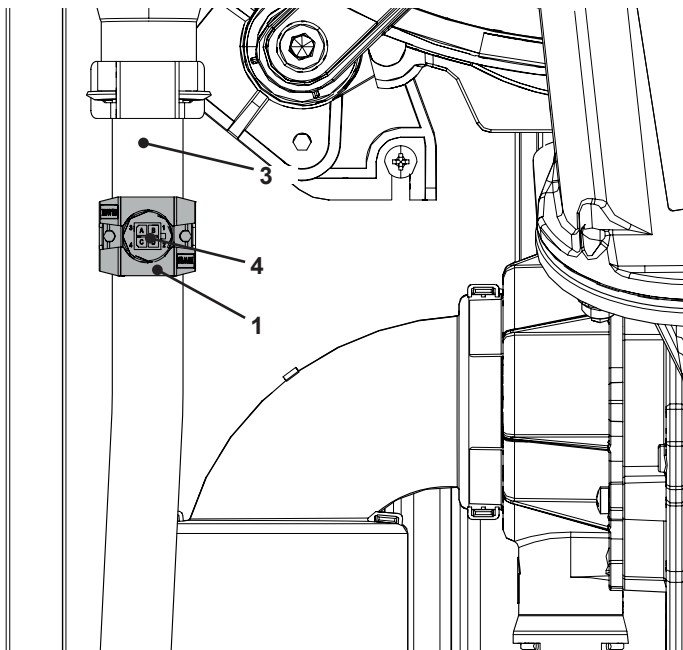

Figure 15.3

### 15.4 Removal of the D.H.W. temperature probe NTC



**Warning:** isolate the boiler from the mains electricity supply before removing any covering or component.

- 1 Remove the front panel of the case and lower the control panel.
- 2 Empty the D.H.W. circuit of the boiler.
- 3 Remove the electric connector "5" (Figure 15.4)
- 4 Unscrew the NTC probe "2".
- 5 Reassemble the NTC probe carrying out the removal operations in reverse order.

## TEMPERATURE PROBE

 **Warning:** to lubricate the O-ring gaskets exclusively use a silicone base grease compatible to be in contact with foods and approved by the local water Authorities.

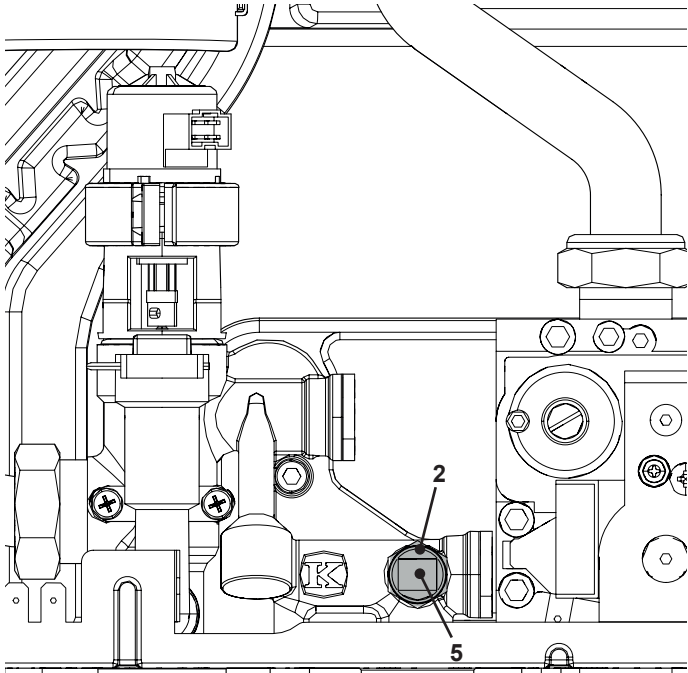

Figure 15.4

# BY-PASS VALVE

## 16 BY-PASS VALVE

### 16.1 Function

The By-pass valve "1" in Figure 16.1 is located between the C.H. water flow and return and its function is that of guaranteeing a minimum flow across the primary heat exchanger if the circulation across the C.H. system is completely closed.

The By-pass valve is fitted on the rear side of the diverter group.

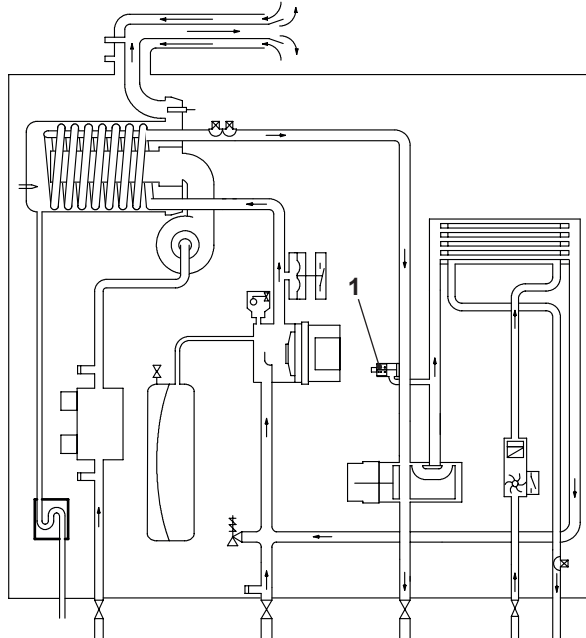

Figure 16.1

reversing the order of removal.



**Warning:** to lubricate the O-ring gaskets exclusively use a silicone base grease compatible to be in contact with foods and approved by the local water Authorities.

### 16.2 Removal



**Warning:** isolate the boiler from the mains electricity supply before removing any covering or component.

- 1 Remove all the case panels.
- 2 Empty the primary circuit of the boiler.
- 3 Unscrew the screws "2" and pull the by-pass valve "1" (Figure 16.2).

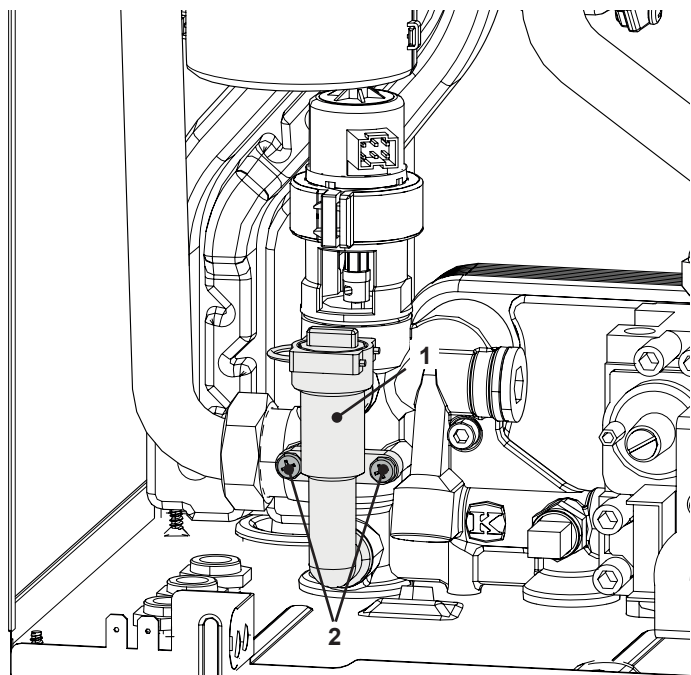

Figure 16.2

- 4 Reassemble the by-pass valve as illustrated in Figure 16.2



## 17 FAN AND AIR BOX

### 17.1 Function

The function of the Fan "1" (Figure 17.1) is to force the mixture of air and gas into the burner.

The function of the Air box "2" is to mix the gas and the air in the right proportion.

The flow rate of the air-gas mixture and consequently the input power of the boiler is proportional to the speed of the fan that is controlled by the electronic control p.c.b.

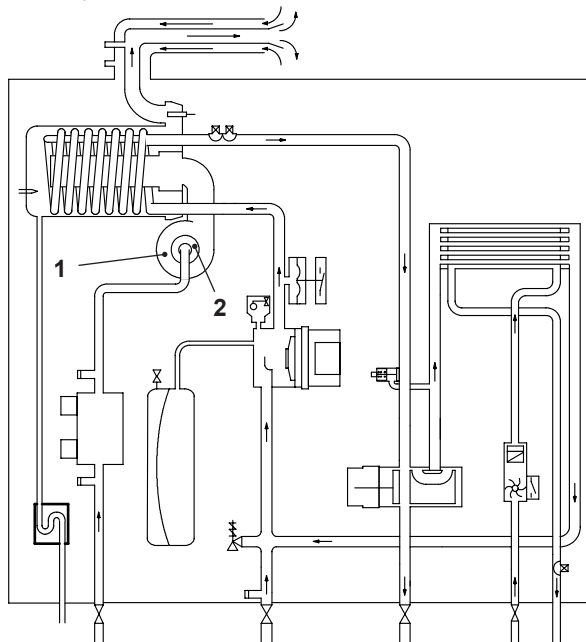



Figure 17.1

### 17.2 Removal of the Air box and the Fan

 **Warning:** isolate the boiler from the mains electricity supply before removing any covering or component.

- 1 Turn off the gas supply.
- 2 Remove all the case panels (see section "2 General access and emptying hydraulic circuits" on page 5).
- 3 Unscrew the gas connector "3" and remove the gas pipe "4" (Figure 17.2).
- 4 Disconnect the connectors "6".
- 5 Unscrew the nuts "5".
- 6 Remove the fan "1" with the air box "2".

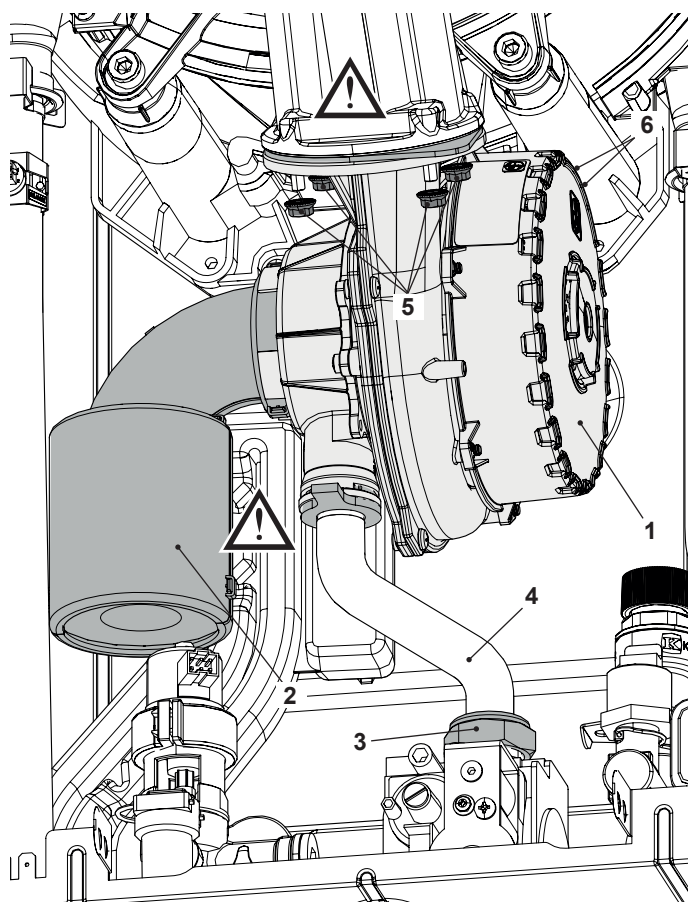

Figure 17.2

- 7 Assemble the Fan carrying out the removal operations in reverse sequence.

Before reassembling ensure the fan gasket (Figure 17.2) is correctly mounted.



**Warning:** Place the seal on the pipe and offer the pipe with O'ring pre fitted into the manifold rather than inserting the O'ring into the manifold and offering the pipe into it.

After any service operation on the components of the gas circuit check all the connections for gas leaks.



**Warning:** After cleaning or replacement as detailed above, it is deemed necessary to undertake a combustion analysis as detailed in section "11.3 Adjustment - Chimney Sweep Function" on page 30.

## IGNITION AND DETECTION ELECTRODES

### 18 IGNITION / DETECTION ELECTRODE AND BURNER

#### Electrodes disclaimer.

Note to service engineers: It is required that the burner seal, lip seal and mixing chamber seal along with the flame detection electrode are inspected every year and replaced every 24 months. Failure to inspect the flame detection probe, seals and replace as required may render the guarantee void.

#### 18.1 Function

The ignition / detection electrode "1" is fitted on the left side of the fan-burner group "4".

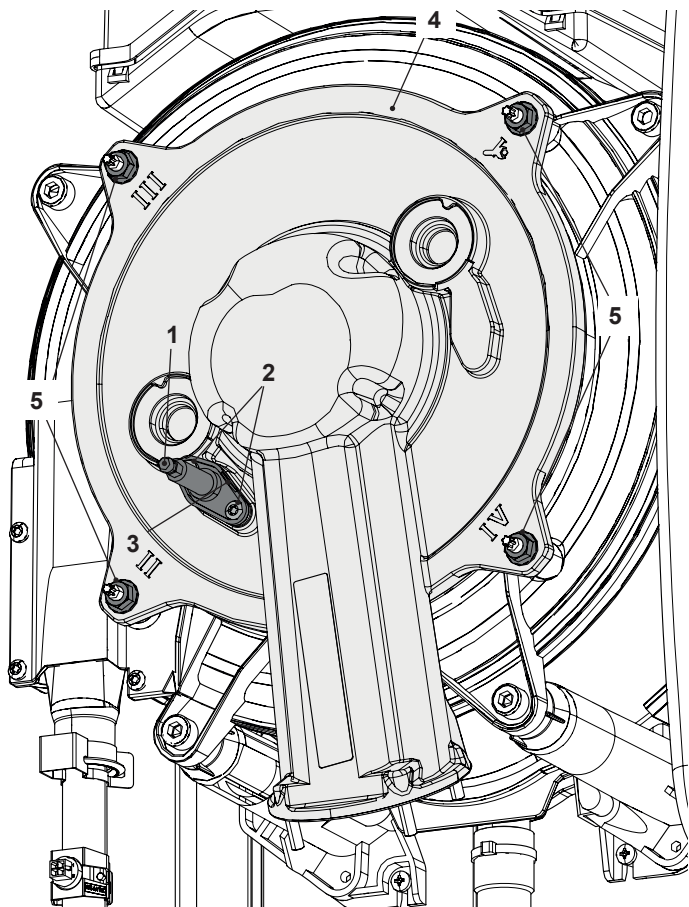

Figure 18.1

The burner "6" is fitted on the rear of the fan-burner group "4".

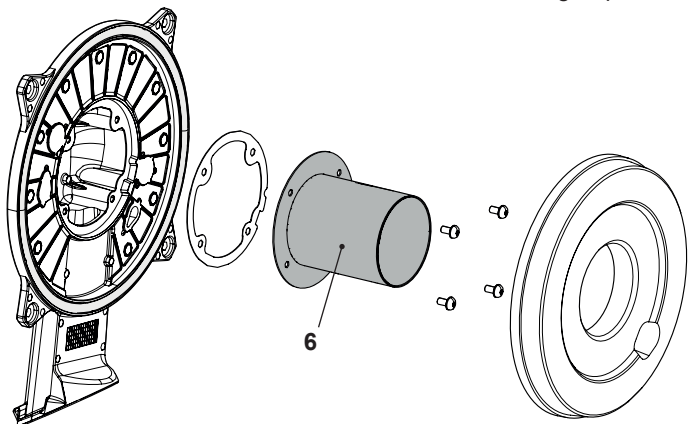

Figure 18.2

#### 18.2 Removal of the ignition / detection electrode



Warning: isolate the boiler from the mains electricity supply before removing any covering or component.

- 1 Remove all the case panels (see section "2 General access and emptying hydraulic circuits" on page 5).
- 2 Disconnect the electrode connector "1" and the earth wire "3" (Figure 18.1).
- 3 Unscrew the screws "2" and remove the electrode "1".
- 4 Assemble the ignition / detection electrode carrying out the removal operation in reverse order.



Warning: A new sealing gasket must be used during refitting of the electrodes on all occasions of removal.

#### 18.3 Removal of the front insulation panel

See warning note at the end of this chapter before to remove this part.

- 1 Remove the ignition / detection electrode (see section "18.2 Removal of the ignition / detection electrode" on page 42).
- 2 Remove the front insulation panel by sliding it forward (Figure 18.3).
- 3 Assemble the new front insulation carrying out the removal operation in reverse order. When fitting the new panel ensure that the electrode hole coincide with the hole of the combustion chamber.

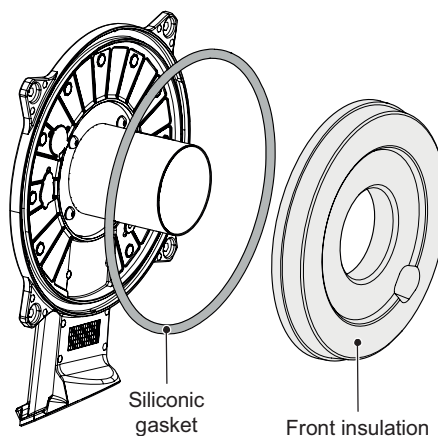

Figure 18.3

#### Caution:

After any periodical servicing or disturbance the combustion chamber silicon seal (Figure 18.3) must be fully inspected and replaced at the discretion of the service engineer. After any disturbance to the chamber door seal the appliance must undergo a full analytical combustion performance check.

#### 18.4 Removal of the burner



Warning: isolate the boiler from the mains electricity supply before removing any covering or component.

- 1 Remove the air box and the fan (see section "17.2 Removal of the Air box and the Fan" on page 41).
- 2 Remove the Ignition and detection electrodes (see section "18.2 Removal of the ignition / detection electrode" on page 42).

## IGNITION AND DETECTION ELECTRODES

- 3 Unscrew the nuts "5" (Figure 18.1) and remove the cover of the combustion chamber.
- 4 Remove the front insulation panel (see section "18.3 Removal of the front insulation panel" on page 42).
- 5 Unscrew the screws "7" (Figure 18.4) and remove the burner.
- 6 Assemble the burner carrying out the removal operation in reverse order. Ensure the burner is correctly located by lining up the locating tab (Figure 18.4).

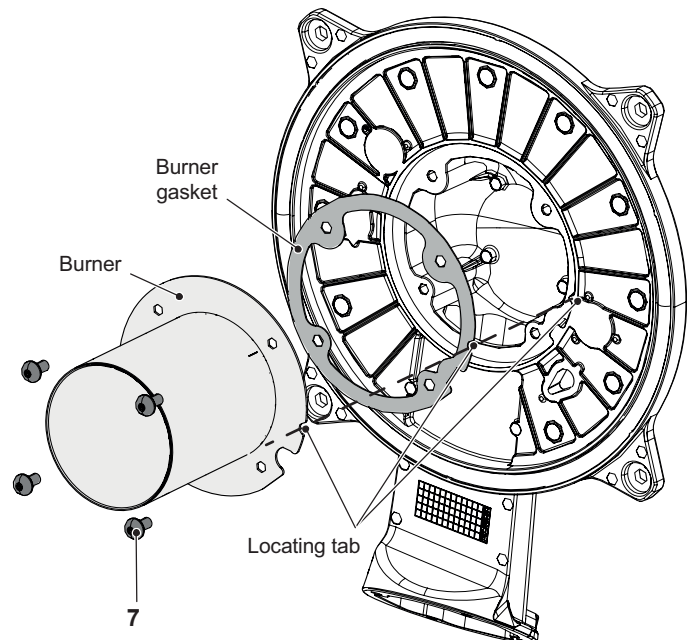

Figure 18.4

Before reassembling ensure the burner gasket is correctly located.



**Warning:** After cleaning or replacement as detailed above, it is deemed necessary to undertake a combustion analysis as detailed in section "11.3 Adjustment - Chimney Sweep Function" on page 30).

### 18.5 Removal of the rear insulation

See warning note at the end of this chapter before to remove this part.



**Attention:** Cover the inner of the condensing heat exchanger to avoid that dirt and debris fall in the coil.

- 1 Do the operations of section "18.4 Removal of the burner" on page 42 from step 1 to step 3.
- 2 Remove the insulation "8" by pulling it towards the boiler front (Hung it with a screwdriver tip) (Figure 18.5).

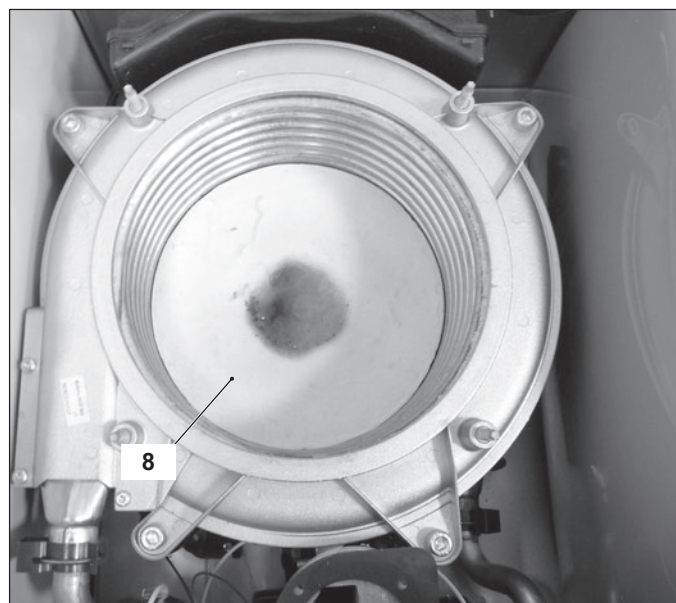

Figure 18.5

### 18.6 Checks

- ✓ Check of the spark generator.



**Warning:** isolate the boiler from the mains electricity supply before removing any covering or component.

There is not a significant way to verify the integrity of the spark generator. When the fan turns but the burner does not light a possible cause is a faulty spark generator on the main PCB. It would be advisable to replace the Main PCB to rectify the fault.

- ✓ Check the position of the electrode edges.



**Warning:** isolate the boiler from the mains electricity supply before removing any covering or component.

- 1 Check for the correct distance between the metallic edge of the electrode and burner (see Figure 18.6).

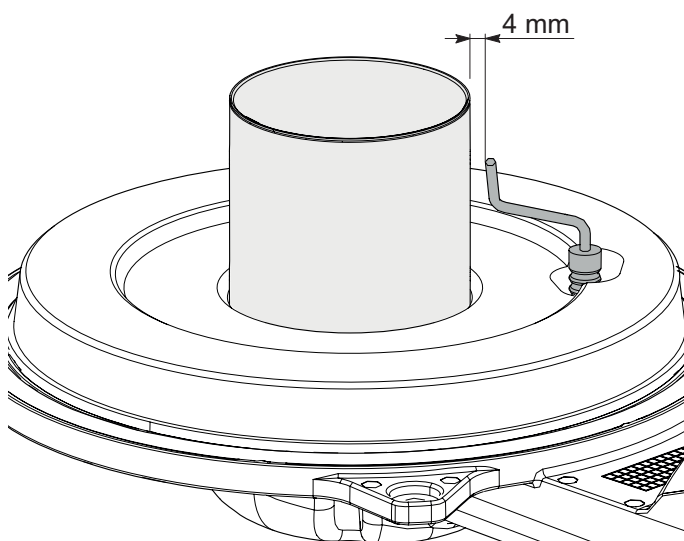

Figure 18.6

- ✓ Check the connection wires

---

## IGNITION AND DETECTION ELECTRODES

---



**Warning: isolate the boiler from the mains electricity supply before removing any covering or component.**

- 1 Remove all the case panels and the sealed chamber lid.
- 2 Check for the integrity of the insulation of wires which connect the electrode.

The electrode in Figure 18.6 also functions as a sensor for the correct drainage of the condensate.

Should the mentioned electrode come into contact with the condensate water present within the combustion chamber it sends the boiler into safety lockout.

Remove any encrustations and dirt from the detection electrode or replace it if damaged.



**In any case, it must be replaced every 2 years.  
The ignition/detection electrode is not under warranty because it is consumable part.**

### **Warning - Insulation panels material handling care.**

Mineral fibres are used in this appliance for the insulation panels of the combustion chamber

Excessive exposure to these materials may cause temporary irritation to eyes, skin and respiratory tract.

Known hazards - Some people can suffer reddening and itching of the skin. Fibre entry into the eye will cause foreign body irritation, which can cause severe irritation to people wearing contact lenses. Irritation to respiratory tract.

Precautions - Dust goggles will protect eyes. People with a history of skin complaints may be particularly susceptible to irritation. High dust levels are only likely to arise following harsh abrasion. In general, normal handling and use will not present high risk, follow good hygiene practices, wash hands before, touching eyes, consuming food, drinking or using the toilet.

First aid - Medical attention must be sought following eye contact or prolonged reddening of the skin.

# FLUE TEMPERATURE PROBE NTC AND SAFETY THERMAL FUSE

## 19 FLUE TEMPERATURE PROBE NTC AND SAFETY THERMAL FUSE

### 19.1 Function

The Flue temperature probe NTC and Safety thermal fuse "1" in Figure 19.1 and Figure 19.2 senses the temperature of the combustion products that flow through the condensing heat exchanger.

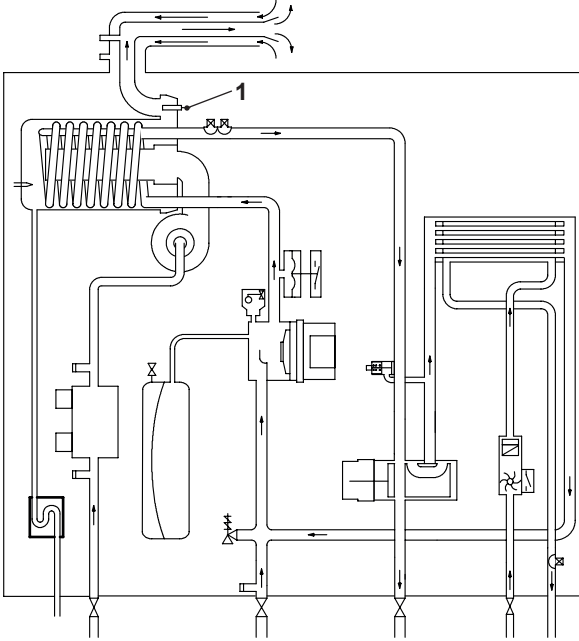

Figure 19.1

If the temperature of the combustion products circuit reaches the limit temperature, the Flue temperature probe NTC reduces the gas flow rate to the burner. The temperature of the combustion products should decrease to a safe value temperature.

In the case that the temperature of the combustion products reaches a potentially dangerous value, the Safety thermal fuse stops the boiler operation (lock-out).

The use of kits different from the original isn't however allowed, since the flue pipes are integral parts of the boiler.

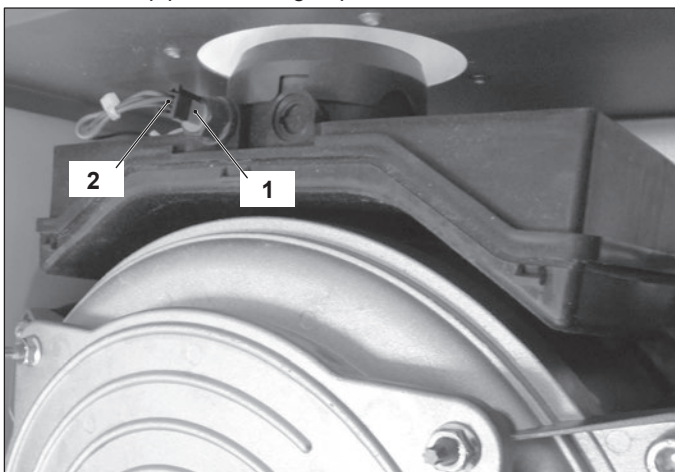

Figure 19.2

A Flue temperature probe NTC and Safety thermal fuse "1" in Figure 19.1 and Figure 19.2 is also connected in series with the Flue temperature probe NTC and acts as a safety device in extreme case of incorrect operation of the Flue temperature control system.

Reaching the breakdown temperature it opens the circuit and locks out the boiler.

In case of intervention of this safety device the heat exchanger (part shown in Figure 19.3) may be damaged and must be re-

placed.

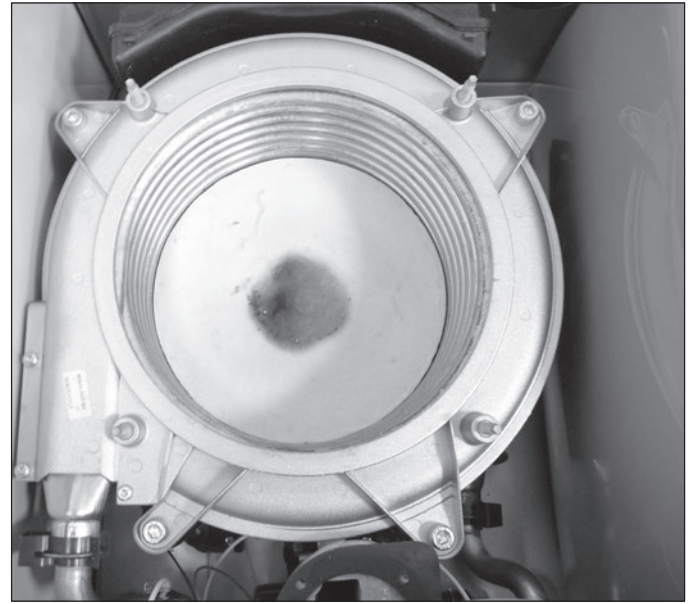

Figure 19.3

### 19.2 Removal



**Warning:** isolate the boiler from the mains electricity supply before removing any covering or component.

- 1 Remove all the case panels.
- 2 Disconnect the connector "2" from the Flue temperature probe NTC and Safety thermal fuse by pressing the plastic hook placed on the side of the connector (Figure 19.2).
- 3 Unscrew and remove the Flue temperature probe NTC and Safety thermal fuse "1" (Figure 19.2) from the condensing heat exchanger.
- 4 Assemble the Flue temperature probe NTC and Safety thermal fuse carrying out the removal operations in reverse sequence.
- 5 Ensure the probe seal is in a good serviceable condition to avoid POC and condensate leakage.

### 19.3 Checks

✓ Overheat temperature value

- 1 Set the temperature control knobs to their max. position and run the boiler in D.H.W. and C.H.
- 2 Allow the boiler to reach its maximum operating temperature (monitor the temperature gauge on the instrument panel). The boiler should maintain a temperature below that of the Flue temperature probe NTC and Safety thermal fuse and no overheat intervention should occur.

✓ Temperature-resistance relationship.

- 1 Remove the Flue temperature probe NTC and Safety thermal fuse (see section "19.2 Removal" on page 45).
- 2 Measure the Flue temperature probe NTC and Safety thermal fuse electrical resistance at the ambient temperature and check it according to the graph in (Figure 19.4).

# FLUE TEMPERATURE PROBE NTC AND SAFETY THERMAL FUSE

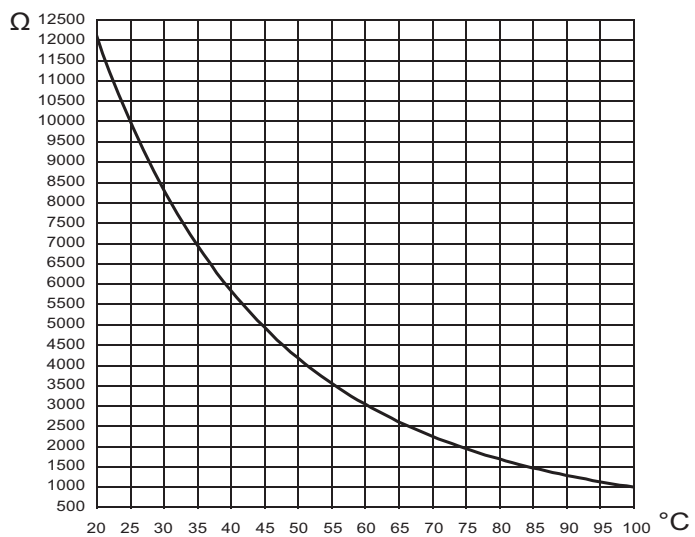

Figure 19.4

# CONDENSATE TRAP

## 20 CONDENSATE TRAP

### 20.1 Function

The condensate trap "1" in Figure 20.1 and Figure 20.2 allows the discharge of the condensate via the condensate drain pipe avoiding in the mean time the escape of combustion products. A plastic ball closes the trap outlet in case that the trap is empty.

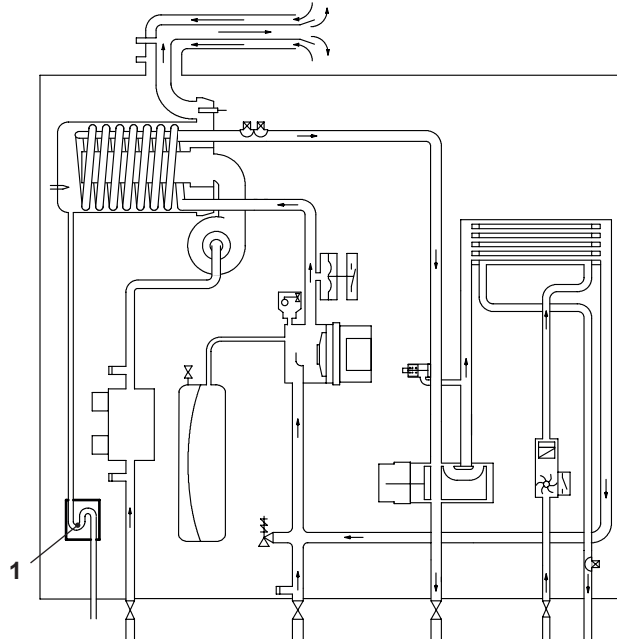

Figure 20.1

If the drain pipe becomes blocked, or condensate cannot drain, the condensate level in the trap rises until it affects the flame detection probe, this will cause the boiler lock-out.

### 20.2 Check the cleanness of the trap

The condensate drain pipe "1" (Figure 20.2) does not require any particular maintenance but just check:

- 1 That no solid deposits have formed, if so remove them.
- 2 That the condensate drain piping is not clogged.

To clean the inside of the siphon, remove it and turn it upside down to remove any dirt (see section "20.3 Removal" on page 47).

### 20.3 Removal



**Warning:** isolate the boiler from the mains electricity supply before removing any covering or component.

- 1 Remove the front and right case panels.
- 2 Using pliers, remove the spring "2" moving it to the left.
- 3 Remove the pipe "3" from the trap "1".
- 4 Remove the trap "1", moving it upwards; from the grommet "4".

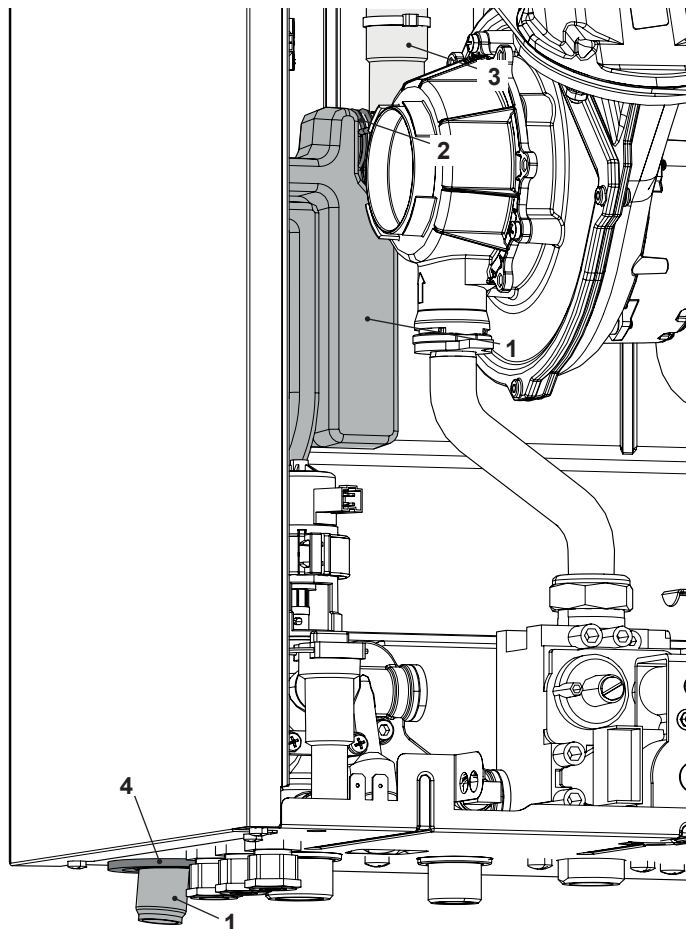

Figure 20.2

- 5 Reassemble carrying out the removal operations in reverse order.

## SHORT SPARE PARTS LIST

### 21 SHORT SPARE PARTS LIST

Key	G.C. part no.	Description	Q.ty	Manufacturer part no.
1		Burner	1	BI1563 102
2		Expansion vessel	1	BI1462 100
3		Condensing heat exchanger (mod. M275V.2024 SM - M275V.2428 SM)	1	BI2002 100
		Condensing heat exchanger (mod. M275V.2832 SM)	1	BI2112 118
4		Fan (mod. M275V.2024 SM - M275V.2428 SM)	1	BI1713 115
		Fan (mod. M275V.2832 SM)	1	BI1713 116
5		Gas valve	1	BI1313 103
6		Safety valve	1	BI1621 101
7		Main electronic control p.c.b	1	BI2605 113
8		D.H.W. heat exchanger (mod. M275V.2024 SM)	1	BI1181 122
		D.H.W. heat exchanger (mod. M275V.2428 SM - M275V.2832 SM)	1	BI1001 102
9		Motor pump	1	BI2112 103
10		Pump	1	BI2112 104
11		D.H.W. temperature probe NTC	1	BI1001 117
12		C.H. temperature flow probe NTC - Safety Thermostat	1	BI1442 117
13		D.H.W. flow switch	1	BI1621 104
14		D.H.W. flow sensor	1	BI1621 112
15		Primary circuit pressure switch	1	BI1592 115
16		Three way diverter valve (electric actuator)	1	BI1621 105
17		Condensate trap	1	BI1782 107
18		Safety thermal fuse	1	BI1772 101
19		Fuse 3,15 AF 250VAC 5x20	1	BI2145 106
20		Ignition / detection electrode	1	BI1663 106



**SHORT SPARE PARTS LIST**

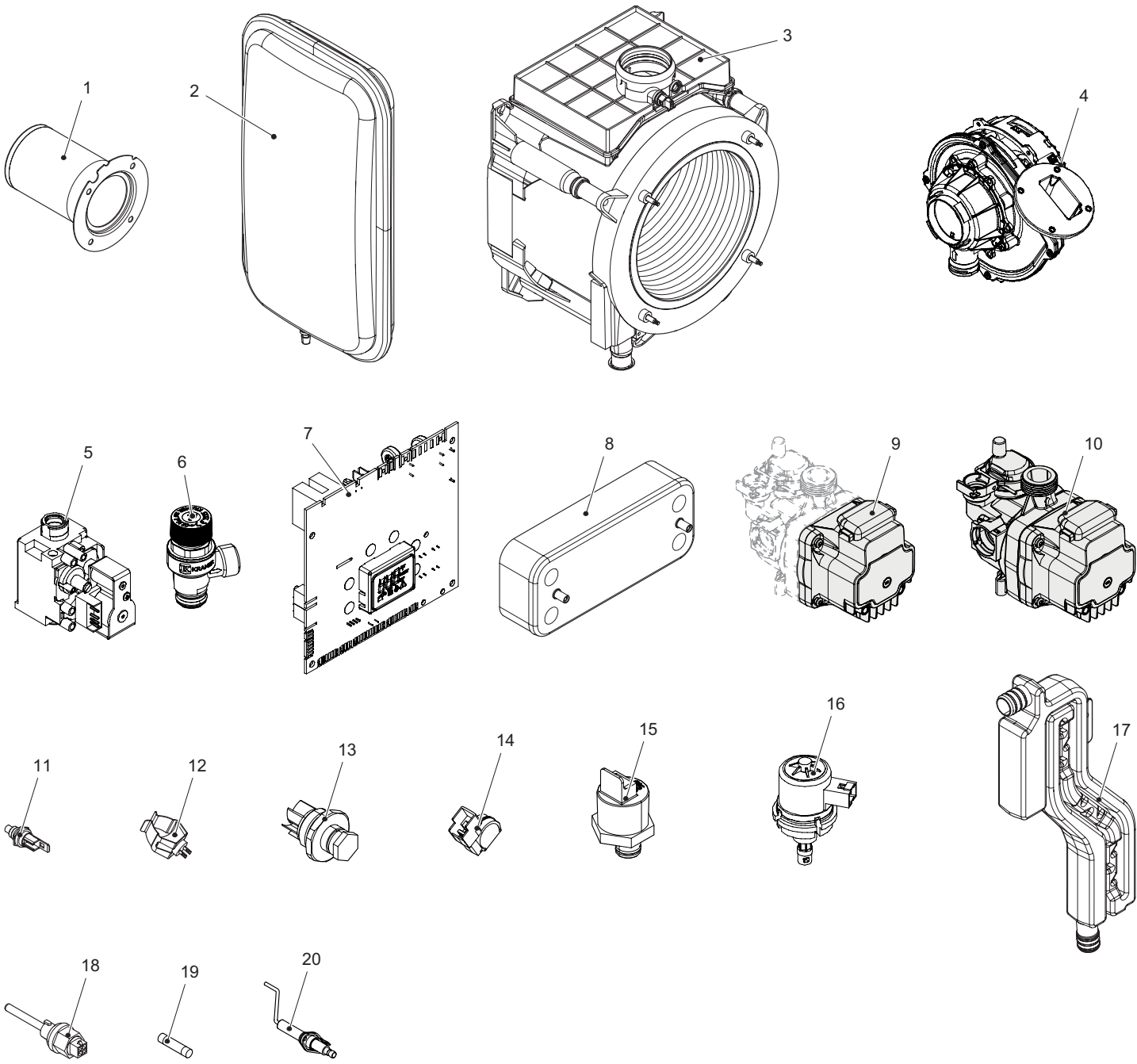

**Figure 21.1**

---

---

## NOTE

---



17962.3485.0 1622 52A4 UK



**Biasi UK Ltd**  
Commercial Road  
Leamore Enterprise Park  
WALSALL

WS2 7NQ

Sales Tel. 01922 714600  
Tech. Service Tel. 01922 714636  
[www.biasi.co.uk](http://www.biasi.co.uk)

