

SG Series Boiler **SG/2 - SG/7**

Distributed By:
QHT
QUINCY HYDRONIC TECHNOLOGIES, INC.
3560 LAFAYETTE RD
PORTSMOUTH, NH 03801
PHONE: 603-334-6400
FAX: 1-877-334-6401
WWW.QHTINC.COM

Please Read Instructions Carefully
Save for Future Reference

WARNING

If the information in this manual is not followed exactly, a fire explosion may result causing property damage, personal injury or loss of life.

DANGER

WHAT TO DO IF YOU SMELL GAS

- Do not try to light any appliance
- Do not touch any electric switch; do not use any phone in your building
- Immediately call your gas supplier from a neighbor's phone. Follow the gas supplier's instructions.
- If you can not reach your gas supplier call the fire department

Installation and service must be performed by a qualified installer, service agency or the gas supplier.



Dear Customer:

Thank you for buying a BIASI SG boiler.

The BIASI SG is a cast iron, oil or gas fired hot water boiler, using the famous 3-pass design. The boiler is light, compact, simple, rugged and engineered for maximum home heating efficiency.

We realize that it is not possible to answer all questions about the SG-series boiler in this manual. Reading this installation manual does not make the reader an expert in all aspects of installation and operation, and does not replace the need for a qualified, licensed heating contractor. We urge you to contact your installing contractor or distributor if you are in question about any aspect of your boiler's performance. Our main concern is that you are satisfied with your boiler and its performance. **We require that your contractor complete efficiency tests using instruments.**

The controls and accessories listed in this manual are intended to serve as guidelines rather than specific recommendations. We realize that other makes and models of such devices are available and can be used as successfully as those we specify. The installing contractor is the best judge of a system's specific requirements, as well as the local availability of certain makes and models of controls and accessories. The preceding does not apply, however, to the equipment that comes with every boiler, such as the overheat control (L7248) and pressure relief valve. **The installation of the specific devices supplied with every boiler is absolutely necessary to the safe operation of the boiler and protection of the heating system.**

All SG-series boilers are built in accordance with the ASME boiler and pressure vessel code, and bear the "H" stamp. The BIASI SG boiler has been tested to UL standard 726.

This BIASI SG boiler has a limited lifetime warranty (refer to back of manual), a copy of which is provided with the boiler. Please be sure to return the warranty registration card as the warranty will be void without your boiler's serial numbers (located on the plate on the leg of the boiler), date of installation and the name of your installer being on record in our files.

Thank you for purchasing our BIASI SG series boiler. If you have questions or comments, please don't hesitate to contact us immediately. Our goal is 100% customer satisfaction.

QHT inc.

Table of Contents

<u>BIASI SG-Series</u>	<u>Section</u>	<u>Page</u>
Important Information & Warnings		5-6
General Information	1	7
Boiler Block Assembly & Explosion Diagram	2	8
Boiler Location	3	9
Installation of Boiler Trim Kit Components	4	10-12
Piping the Boiler	5	13
Intake Venting	6	14-15
Exhaust Venting	7	16
Common Exhaust Venting	7.1	16-17
Block Flue Switch	7.2	17
Gas Venting	7.3	18
Burner Setup	8	18
Oil	8.1	19
Gas	8.2	20
Gas Line Piping	9	21
Boiler Jacket Assembly	10	22
Control Panel	11	23
Wiring	12	24
Oil Diagrams	12.1	25-27
Gas Diagram	12.2	28
SG Efficiency Control	13	30-33
Commissioning the Boiler	14	34
Maintenance	15	34
Installer Notes	16	35
Homeowner Information	17	36
Warranty		Back Cover

This installation manual is for the basic installation of a SG series boiler for atmospheric venting for oil and gas. **If you are installing a direct vent system or please refer to its addendum in conjunction with this manual to insure the proper installation of the boiler.**

IMPORTANT INFORMATION

Please read this page carefully.

- **ALL BOILERS MUST BE INSTALLED IN ACCORDANCE WITH NATIONAL, STATE AND LOCAL PLUMBING, HEATING AND ELECTRICAL CODES AND ORDINANCES, AS WELL AS THE REGULATIONS OF THE SERVING ELECTRICAL, WATER AND GAS UTILITIES.**
- **All systems should be designed by competent contractors, and only persons knowledgeable in the layout and installation of heating systems should attempt the installation of any boiler. It is the responsibility of the installing contractor to see that all controls are correctly installed and operating properly when the installation is completed.**
- **Do not burn volatile garbage, gasoline, naphtha or other flammable liquids other than No. 2 fuel oil. All flammable liquids (especially gasoline), chemicals, rags, paper, wood scraps, debris, etc., should be kept away from the boiler at all times. Keep the boiler area clean and free of all fire hazards.**
- **Please read the literature and warranties supplied by the manufacturers of the various accessory equipment. This equipment is warranted by the respective manufacturers, not by Quincy Hydronic Technologies, Inc. Each piece of equipment must be installed and used according to the recommendations of the manufacturer.**

Codes and Regulations:

Installation of the boiler, burner, oil tank and related equipment must conform to national, state and local regulating agencies and codes applicable to the installation of the equipment. In the absence of local requirements, the following codes apply:

- A. ANSI/NFPA - #31 Installation of Oil Burning Equipment
- B. ANSI/NFPA - #70 National Electric Code
- C. ANSI/NFPA - #211 Chimneys and Vents
- D. ANSI/NFPA - #Z223.1 National Fuel Gas Code
- E. ANSI/NFPA - Domestic Gas Conversion Burner
- F. CAN/CGA - B149 Installation Codes
- G. ANSI/ASME - CSD-1

The above codes are available from:

National Fire Protection Association (NFPA)
Battery March Park
Quincy, Massachusetts, 02269
<http://www.nfpa.org>

American Gas Association (AGA)
Pleasant Valley Road
Cleveland, OH 44134
<http://www.aga.org>

WARNING

Any appliance that burns natural gas, propane gas, fuel oil, wood or coal is capable of producing carbon monoxide (CO). Carbon Monoxide (CO) is a gas which is odorless, colorless and tasteless but is very toxic. CO is lighter than air and thus may travel throughout the building.

**BRIEF EXPOSURE TO HIGH CONCENTRATIONS OF CO, OR
PROLONGED EXPOSURE TO LESSER AMOUNTS OF CO MAY RESULT
IN CARBON MONOXIDE POISONING. EXPOSURE CAN BE FATAL AND
EXPOSURE TO HIGH CONCENTRATIONS MAY RESULT IN THE
SUDDEN ONSET OF SYMPTOMS INCLUDING UNCONSCIOUSNESS.**

Symptoms of CO poisoning include the following:

dizziness	vision problems	shortness of breath
headache	loss of muscle control	unclear thinking
nausea	weakness	unconsciousness

The symptoms of CO poisoning are often confused with those of influenza, and the highest incidence of poisoning occurs at the onset of cold weather or during flu season. A victim may not experience any symptoms, only one symptom, or a few symptoms. **Suspect the presence of carbon monoxide if symptoms tend to disappear when you leave your home.**

The following signs may indicate the presence of carbon monoxide:

- | | |
|---|---|
| <ul style="list-style-type: none"> * Hot gasses from appliance, venting system pipes or chimney, escaping into the living space. * Flames coming out around the appliance. * Yellow colored flames in the appliance. | <ul style="list-style-type: none"> * Stale or smelly air. * The presence of soot or carbon in or around the appliance. * Very high unexplained humidity inside the building. |
|---|---|

If any of the symptoms of CO occur, or if any of the signs of carbon monoxide are present, **VACATE THE PREMISES IMMEDIATELY AND CONTACT A QUALIFIED HEATING SERVICE COMPANY OR THE GAS COMPANY OR THE FIRE DEPARTMENT.**

ONLY QUALIFIED, LICENSED SERVICE CONTRACTORS SHOULD PERFORM WORK ON YOUR BIASI SG BOILER.

1. General Information

The BIASI SG-series boilers are wet base design, sectional, cast-iron boilers for forced hot water heating systems. The boilers are shipped pre-assembled from the factory in lengths from two to seven sections. They are designed for firing with oil or gas power burners, which are packed separately along with the jacket and controls for shipping purposes.

When the boiler is received, check the contents to ensure that there is no shortage or damage to any part of the boiler system. With every boiler you should receive a boiler block, jacket, trim kit and a burner (oil or gas).

Trim Kit Components-

- | | |
|--|----------------------------------|
| 1 - Honeywell L7248 aquastat | 1 - 30 PSI pressure relief valve |
| 1 - Immersion wells | 1 - 3/4" Boiler drain |
| 1 - 3/4" X 3" Nipple | 1 - 3/4" 90° Elbow |
| 1 - Control panel with temperature and pressure gauges | 1 - Hinge Assembly |
| 1 - Double acting barometric damper (gas systems only) | 1 - 12"x12" Cera-fiber Blanket |
| | 1 - Burner mounting hardware |

USE ONLY THE ETL LISTED BOILER SYSTEM COMPONENTS AND UL/AGA LISTED GAS BURNER COMPONENTS SUPPLIED WITH THE BIASI SG BOILER.

Boiler Model	Heating Capacity MBH	Gross Input Burner Capacity		Net Output NET MBH	Efficiency %	Water Content GALS.	Length (L)		Weight LBS
		GPH	MBH				IN.		
SG-2	79	0.65	91.0	69	85.1	6.9	16.7	264	
SG-3	123	1.00	140.0	107	86.1	7.7	21.8	341	
SG-4	160	1.30	182.0	139	86.5	9.6	26.9	418	
SG-5	201	1.60	224.0	175	87.7	11.3	32.1	506	
SG-6	232	1.90	266.0	202	85.3	13.1	37.2	605	
SG-7	279	2.25	315.0	243	86.8	14.9	42.3	704	
Maximum Water Working Pressure 50 psi					Maximum Relief Valve is 50 psi at 500 MBH				

2. Boiler Block Assembly

All SG series boilers are shipped from the factory in assembled boiler blocks. If the block needs to be split into sections for ease of delivery, please read the following:

To assemble split blocks, move sections into parallel and facing each other. Sections may be slid along boards placed underneath the sections. Inspect nipple ports for damage or burrs. Remove any burrs by scraping the port very lightly. Wipe the push nipples and nipple ports with a clean cloth. Apply a film of nipple compound to both the nipple and port. Install the nipple in the port and then seal by hitting with a hammer cushioned with a block of wood. Apply section sealant to one section only and slide sections together. Install the four draw rods and draw the sections together evenly (measure with yardstick). Draw the sections together until sections make iron-to-iron contact at a point around the top and bottom ports of each section.

DO NOT OVER TIGHTEN DRAW RODS

After assembly of boiler block, seal all joints with boiler gasket and remove boards. NOTE: When cutting off excess length of draw rods, allow enough length to install boiler jacket on the draw rods.

Boiler Components & Parts BIASI SG-Series

- | | |
|----------------------------------|-------------------------------|
| 1) Door Alignment Pin | 11) Draw Rod |
| 2) Hinge Stud, Nut and Washer | 12) SG Door |
| 3) Upper Hinge Element | 13) Door Stud, Nut and Washer |
| 4) SG Front Block Section | 14) Lower Hinge Element |
| 5) SG Rear Block Section | 15) Door Rope Gasket |
| 6) SG Intermediate Block Section | 16) SG Door Refractory |
| 7) Lower Front Bushing | 17) Exhaust Breeching |
| 8) Front Tapping Gasket | 18) SG Nipple |
| 9) Upper Front Bushing | 19) Door Sight Plug |
| 10) Lower Rear Bushing | |

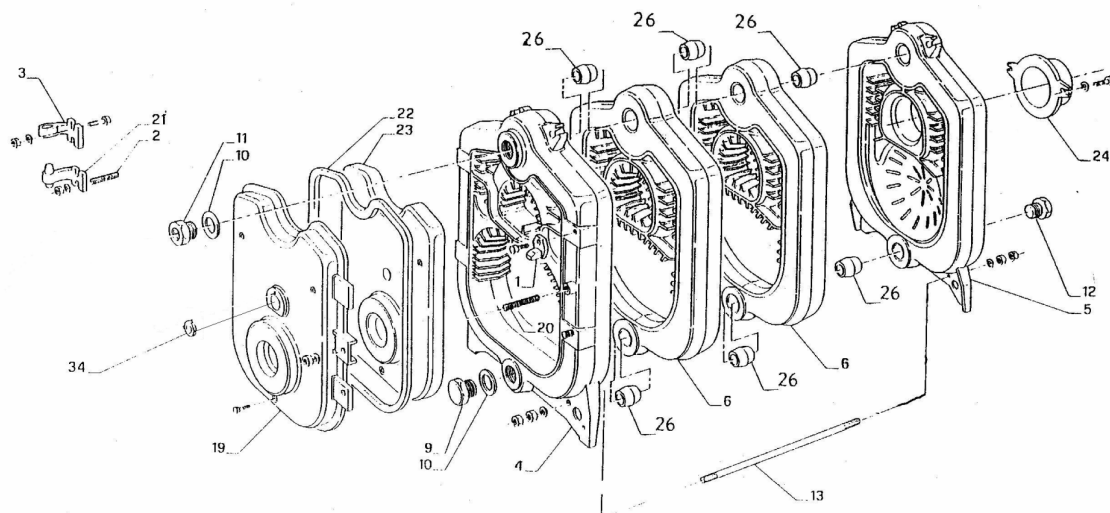

3. Boiler Location

The following are the minimum clearance to construction or combustible materials:

1. 9" from the top, sides, and rear of the boiler.
2. 18" from the flue pipe in any direction.
3. 24" inches from the front of the boiler.

DANGER

The boiler must be located on a non-combustible floor. A smooth, level concrete floor is recommended. Locate the boiler as close as possible to the chimney. If boiler is installed on combustible flooring, consult local authorities for proper method of covering floor. The boiler must not be installed on carpeting.

Caution: Do not store or use flammable materials, chemicals or flammable liquids, especially gasoline, in the vicinity of this heating appliance.

If the boiler is to be installed in "direct vent" configuration, please refer to the QHT Direct Vent Addendum supplied with the Direct Vent Kit.

PROVISIONS FOR COMBUSTION AIR AND VENTILATION AIR MUST BE IN ACCORDANCE WITH SECTION 5.3, AIR FOR COMBUSTION AND VENTILATION, OF THE NATIONAL FUEL GAS CODE, ANSIZ223.1, OR APPLICABLE PROVISIONS OF THE LOCAL BUILDING CODES. **DO NOT INSTALL THE BOILER UNTIL PROPER COMBUSTION AIR HAS BEEN ARRANGED.**

WARNING

Boiler is certified as an indoor appliance. Do not install boiler outdoors or locate where it will be exposed to freezing temperatures

4.1 Installation of Boiler Trim Components

Trim Kit Components:

- | | |
|----------------------------------|--|
| 1 - Honeywell L7248 aquastat | 1 - $\frac{3}{4}$ " 90° Elbow |
| 1 - Immersion wells | 1 - Control panel with temperature and pressure gauges |
| 1 - $\frac{3}{4}$ " X 3" Nipple | 1 - Double Acting Barometric Damper with Manual Reset Spill Switch (Gas systems only) |
| 1 - 30 PSI pressure relief valve | |
| 1 - $\frac{3}{4}$ " Boiler drain | |
| 1 - 12"x12" Cera-fiber blanket | |
| 1 - Burner mounting hardware | |

USE ONLY THE ETL LISTED BOILER SYSTEM COMPONENTS AND UL/AGA LISTED GAS BURNER COMPONENTS SUPPLIED WITH THE BIASI SG BOILER.

Please refer to figures below for Barometric Damper location (gas burners only) and to the right for the proper location of the trim components.

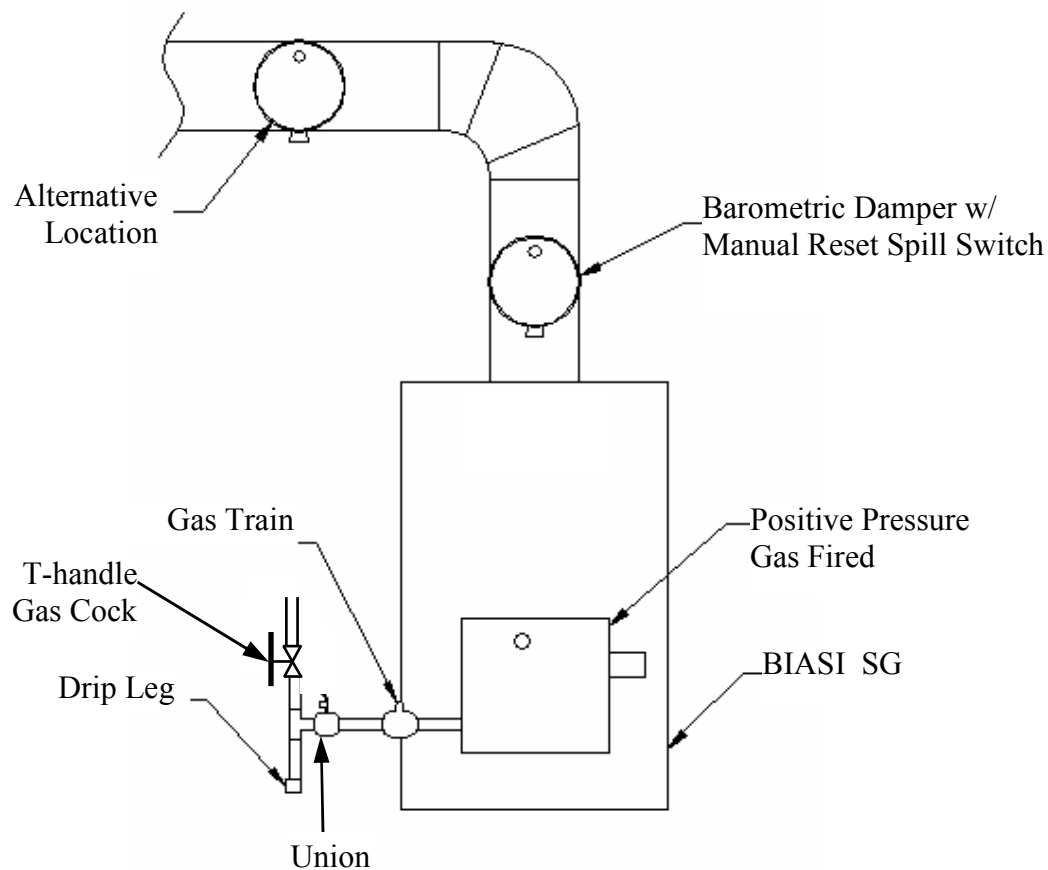

4.1 Installation of Boiler Trim Components Cont.

1. Install the L7248 aquastat sensor in upper left or right rear tapping using 3/4" immersion well. All tapings and joints should be sealed with piping compound. The L7248 can be adjusted up to 220° F, and should be set to the desired temperature by the installer. The differential is fixed at 30 degrees to keep the boiler from short cycling.
2. Install Pressure Relief Valve in opposite upper rear tapping using 3" nipple and 3/4" elbow
3. Install 3/4" boiler drain in lower rear tapping,
4. Install remote pressure sensor from the control panel in lower front tapping of the boiler.
5. Install remote temperature probe and operating aquastat sensor from control panel into immersion well in the upper front tapping. Both sensors are installed in the same well.
6. Install burner mounting hardware in the four tapings on the front of the boiler door.

Boiler Tapping Diagram:

All dimensions are in inches.

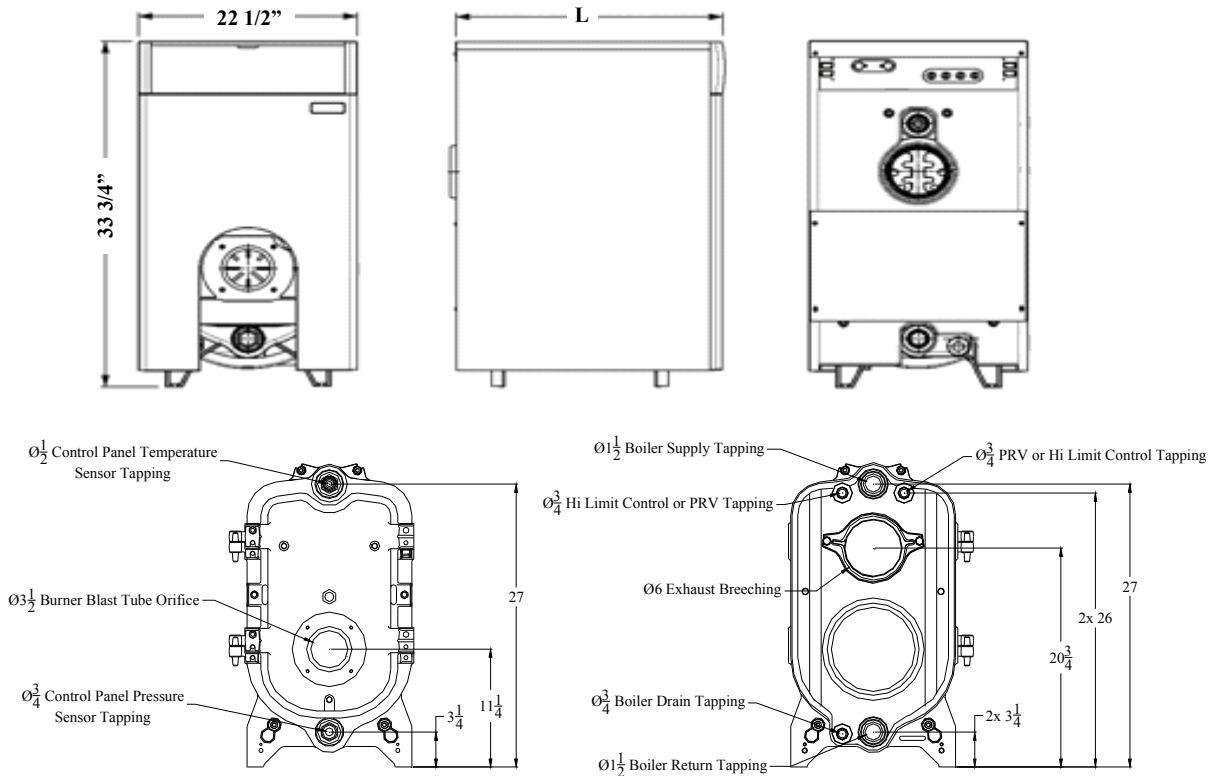

Boiler Model	SG-2	SG-3	SG-4	SG-5	SG-6	SG-7
Length (L) IN.	16.7	21.8	26.9	32.1	37.2	42.3

4.2 Installation of Boiler Door Hinge

1. Remove the boiler door by unscrewing the two nuts holding the door onto the boiler
2. Take the lower hinge elements (it has the pins on the ends) and place them on the upper and lower studs of the side of the boiler that you want the door to swing towards. Install them such that the stud comes through the upper “U”-section and the pin on the boiler block is under the lower “U” section of the hinge. (see Figure 4.1 below) Tighten each with a washer and a nut.
3. Next place the door catch under the top post of the side opposite that on which the hinges are mounted. This is mounted in a similar manner to the hinges. Tighten with a washer and a nut.
4. Place the bolts with a washer on each through the back of the ears on the door in the upper and lower holes on the same side as the hinges are mounted on.
5. Place the upper hinge element onto the bolt and tighten with a washer and a nut.
6. Place the doors hinges onto the pins of the hinge on the boiler.
7. The installation of the hinge is complete. Now, close the door and put the nuts and washers back onto the door to keep shut

SG Hinge Kit Contents:

- 5—Nuts
- 7—Washers
- 2—Bolts
- 2—Lower hinge elements
- 2—Upper hinge elements
- 1—Door Catch



5. Piping the Boiler

All piping must conform to state and local codes. Page 7 shows the location and size of the boiler tapings. Be sure to allow enough room to clear the casing by installing sufficient sized nipples. It is recommended to install unions and gate valves at the inlet and outlet of the boiler, so it may be readily isolated for service.

Install the provided pressure relief valve so the discharge is piped directly to a drain, if possible. If not, the discharge should be piped to the floor. In either case, the discharge pipe should be of the same diameter as the outlet of the relief valve, with no valves or obstructions to impede overflow from the boiler.

For **Canadian** installations it is required to install a low water cut off if the boiler is installed above the level of radiation. Even if the boiler is installed below the level of radiation it is strongly recommended that a low water cut off be installed.

Install manual and/or automatic air venting devices at the high points in the system to eliminate trapped air. The weight of all piping should be supported by suitable hangars and floor stands, not by the boiler's purging/expansion station. Clearance for hot water pipes are 1 inch to combustibles.

It is recommended that the make-up water line have a backflow preventer and a pressure-reducing valve to reduce line pressure to 10 to 15 psi installed adjacent to the boiler.

In the case of a gas installation, the boiler should be installed such that the gas ignition system components are protected from water (dripping, spraying, etc.) during appliance operation and service (circulator replacement, condensate trap, control replacement, etc.).

If the boiler is to be used in conjunction with a refrigeration system, it must be piped in parallel with refrigeration system with the appropriate valves to ensure the chilled medium does not enter the boiler. Also if the boiler is connected to heating coils in an air handling system, where the coil could be exposed to cold air circulation. The boiler must have flow control valves or other automatic means to prevent gravity circulation of the boiler water during the cooling cycle.

NOTE: If the heating system is to be filled with antifreeze, use only formulations expressly made for hydronic heating systems (such as propylene glycol). **Do not use automotive types of antifreeze (ethylene glycol).** Use of antifreeze will alter system output and characteristics. Consult a factory representative for details or assistance.

SAFETY RELIEF VALVE

1. The safety relief valve should be piped into one of the two upper tapings in the rear of the boiler
2. The relief valve should be piped in with a doping compound using the supplied hardware in the trim kit
3. Pipe the discharge of the safety relief valve to prevent injury in the event of pressure relief. Pipe the discharge to a drain. Provide piping that is the same size as the safety relief valve outlet.

6. Intake Venting

1. Be certain adequate air is available for combustion and ventilation.

a.) Boiler located in unconfined space:

Installation in large areas, such as basements can usually be assumed to provide sufficient air.

b.) Boiler located in confined space:

If all air for combustion and ventilation is to come within the building: Two (2) openings shall be provided with one (1) opening commencing within 12 inches of the top and one (1) opening commencing within 12 inches of the bottom of the enclosure. These openings shall not be located closer than 3 inches from either the top or bottom of the enclosure and shall be open to areas connecting freely with the outdoors. The area of each opening shall not be less than one square inch per 1000 BTU/HR. of total input rating of all appliances within the enclosure; with a minimum of 100 square inches for each opening.

If all the air for combustion and ventilation is to come from outside the building; two (2) openings shall be provided with one opening commencing within 12 inches of the top and an opening commencing within 12 inches of the bottom of the enclosure. These openings shall not be located closer than 3 inches from either the top or bottom of the enclosure, and shall connect directly or by ducts with the outdoors. The area of each opening shall be equal to one square inch per 4000 BTU/HR of total input rating. If ducts are used to convey the air, vertical ducts require areas of one square inch per 4000 BTU/hr horizontal ducts require one square inch per 2000 BTU/hr. Ducts shall have the same cross sectional area as the full area of the openings to which they connect.

The upper opening is essential for maintenance of proper circulation of air with the boiler and reasonable ambient temperature in order to maintain proper control temperatures. When a duct is used for ventilation, check for louver free net area and correct for screen resistance to ensure that the ventilation area has been satisfied. **DO NOT INSTALL THE BOILER UNTIL PROPER COMBUSTION AIR HAS BEEN ARRANGED.**

c.) Boiler located in a room under negative pressure:

If the boiler is to be installed within a home where the operation of exhaust fans, attic fans, kitchen ventilation systems, clothes dryers or fireplaces may create severe negative vent pressures causing unsatisfactory combustion and venting, special provisions should be made for additional make-up air to supply the other air requirements. If building is of tight construction, combustion air requirements may not be met and combustion air ducts from outside may be necessary. Please refer to NFPA No. 31.

6. Intake Venting Cont.

Tight Construction (as defined by ANSI Z223.1):

1. Walls and ceilings exposed to the outside atmosphere have a continuous water vapor retarder with a rating of 1 perm or less with openings sealed with gaskets, etc..
2. Weather-stripping has been added on open able windows and doors, and...
3. Caulking or sealants are applied to areas such as joints around windows and door frames, between sole plates and floors, between wall-ceiling joints, between wall panels, at penetrations for plumbing, electrical, and gas lines, and in other openings.

If the building is of tight construction, air openings must be provided from the outside, with appropriate sizing depending on amount of Btuh as shown in pictures.

The area that the boiler is in must never be under a negative pressure, even if the appliance is installed as direct vent. Always provide air openings sized not only to the dimensions required for the firing rate of all appliances, but also to handle the air movement rate of the exhaust fans or air movers using air from the building or space.

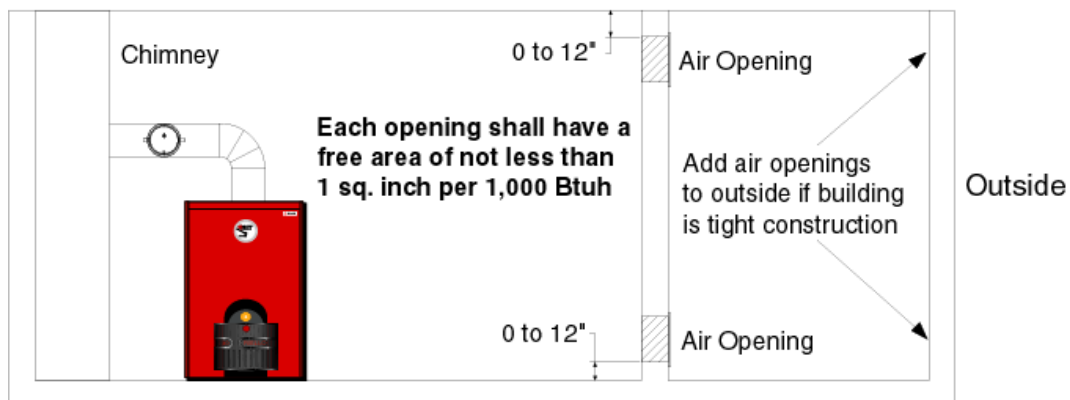
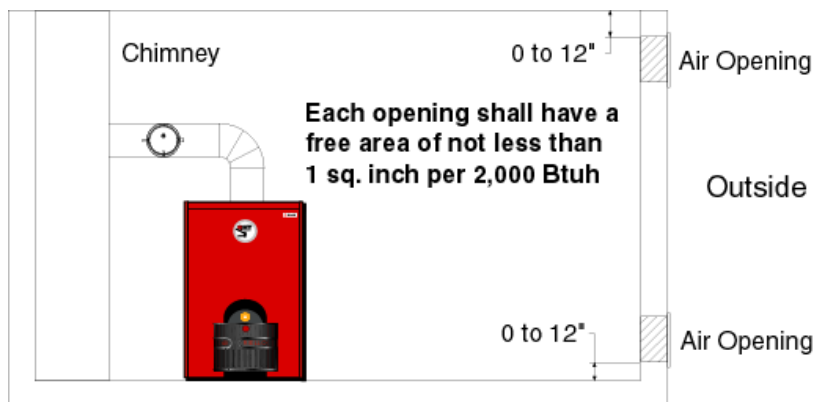

7. Exhaust Venting

The SG boiler is a high efficiency unit that requires proper venting. The boiler must be vented to the outdoors by means of a tile lined masonry or an approved pre-fabricated chimney of the size and height recommended by the manufacturer or by a listed "power venting" unit which provides draft by mechanical venting. In many installations, particularly older interior and most exterior chimneys, a corrosion resistant liner should be installed. Please consult liner manufacturer for the appropriate chimney liner.

The chimney discharge opening must be located at least 24 inches above any part of the building structure within 4 feet of the chimney. Be sure the chimney and smoke pipe don't become obstructed by squirrels, bird nests, soot buildup, chimney liner deterioration, etc.. If using a "power venter" system, it is suggested that it should be installed on the leeward side of the house. (Please consult with manufacturer of "power venter" for requirements concerning clearances from combustibles and distances from doors and windows.) The "venter" must be installed by a licensed burner mechanic and done in accordance with local codes. This is a very low stack temperature boiler (350F gross temp.) so caution should be used when connecting to an outside built chimney. Should you have concern that the flue gases could condense, then you should consider lining the chimney or using a listed, "power venting" or "direct venting unit". If "power venting" is used to discharge flue gases, then the power vent unit should be equipped with a postpurge control such as a delay-off, timing control to prevent problems with fogging and nozzle post drip.

The determining connection from the boiler to the chimney should be as short as possible, with a minimum number of elbows. The vent pipe must have a vertical rise of at least 1/4 inch per foot of horizontal run. The vent pipe must be of the same diameter as the flue outlet on the boiler. The chimney connector should have a minimum thickness of 24 gauge, corrosion resistant (galvanized) steel, assembled with a minimum of three (3) sheet-metal screws in each joint. In some houses, a barometric draft control isn't required as the SG is designed to be pressure-fired, however in high draft situations which exceed the flue gas resistance through the boiler, a barometric draft control is recommended. The over fire draft should be between 0 and .06 inches of water column. The draft at the breech should be enough to overcome the over fire draft at all times.

7.1 Common Exhaust Venting

Common vent exhaust:

If this boiler is replacing one that was part of a common venting system, it is likely that the vent is too large to vent the appliances still attached to it. To prevent this, at the time of removal, the following steps shall be followed with each appliance remaining connected to the common venting system. Place each unit in operation, while the other appliances remaining connected to the common venting system are not in operation.

1. Seal any unused openings in the common venting system.
2. Visually inspect the venting system for proper size and horizontal pitch and determine there is no blockage or restriction, leakage, corrosion and other deficiencies which could cause an unsafe condition.

7.1 Common Exhaust Venting Cont.

3. Insofar as practical, close all building doors and windows and all doors between the space in which the appliance remaining connected to the common venting system are located and other spaces of the building . Turn on any appliance not connected to the common vent system. Turn on all exhaust fans except for summer exhaust fans. Close the fireplace damper if applicable.
4. Place in operation the appliance being inspected. Follow the lighting instructions. Adjust thermostat so appliance will operate continuously.
5. Test for spillage at the barometric damper after 5 minutes of main burner operation. Use the flame of a match or candle, or smoke from a cigarette, cigar or pipe.
6. After it has been determined that each appliance remaining connected to the common venting system property vents when tested as outlined above, return doors, windows, exhaust fans, fireplace dampers and any other gas-burning appliance to their previous condition of use.
7. Any improper operation of the common venting system should be corrected so the installation conforms with the National fuel Gas Code, ANSI Z223.1 and/or CAN/CGA B149, Installation Codes. When resizing any portion of the common venting system, the common venting system should be resized to approach the minimum size as determined using the appropriate tables in Part 11 of the National Fuel Gas Code, ANSI Z223.1, and/or CAN/CGA B149, Installation Codes.

7.2 Blocked Flue Switch:

1. Pierce a 5/8" hole into the vent pipe near the appliance outlet. Remove one of the securing nuts from the pipe of the safety switch. Tighten the other securing nut onto the pipe as far as possible.
2. Insert the threaded pipe end into the pierced hole, then install the securing nut, then install the securing nut, which was removed in step 1, and tighten securely.
3. Please consult the wiring section of this manual for the wiring of the blocked flue switch.

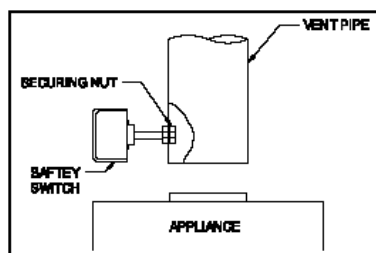

Figure 2

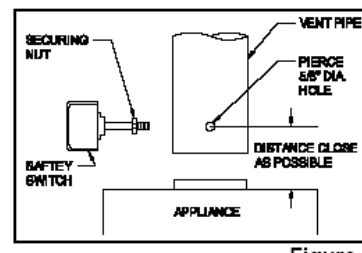

Figure 1

7.2 Gas Venting

For boilers connected to gas vents or chimneys, vent installations shall be in accordance with part 7, Venting of Equipment, of the National Fuel Gas Code, ANSI Z223.1 or Section 7, Venting Systems and Air Supply for Appliances, of the CAN/CGA B149, Installation Codes, or applicable provisions of the local building codes.

Vent connectors serving appliances vented by natural draft shall not be connected into any portion of mechanical draft systems operating under positive pressure.

8. Burner Setup

Good, reliable operation with a minimum of service starts with attention to the small details:

1. Setting the nozzle position and electrodes "by the book" using the manufacturer's gauges.
2. Installing a quality micron filter at the burner.
3. Making careful/tight flare connections without couplings on oil suction line.
4. Checking fuel pump pressure.
5. Checking draft at the breeching to insure it is adequate to overcome flue gas resistance.
6. Setting the air band properly with well maintained instruments. A good target is 11% to 12.5% of (CO₂) or 6.5% to 3.8% of (O₂).

To ensure proper burner setup, gauges should be used to check things such as the pump pressure, CO₂ levels, etc...

8.1 Oil Burner Setup

This page is only for boilers using an oil burner. If a gas burner is being used, please refer to page 13 for the proper setup of the burner and gas lines.

BURNER MANUFACTURER		Beckett		
NX				
Boiler Model	SG-2	SG-3	SG-4	
Burner Model	NEC 1201	NEC 1202	NEC 1202	
Firing Rate	0.65	1.00	1.30	
Insertion Depth	3.5"	6"	6"	
Nozzle	0.50 X 60	.75 X 60B	1.00 X 60B	
Spray Pattern	A	B	B	
Pump Pressure	180 psi	180 psi	180 psi	
Head Type	6-slot	9-slot	9-slot	
Head Position	1.25	2.5	4.5	

BURNER MANUFACTURER		Heatwise				
Pioneer Series						
Boiler Model	SG-2	SG-3	SG-4	SG-5	SG-6	SG-7
Burner Model	P-1 FV*	P-1 KA	P-2 KA	P-2 KA	P-2 K	P-2 K
Firing Rate	0.65	1	1.3	1.6	1.9	2.25
Insertion Depth	3.5"	3.5"	3.5"	3.5"	3.5"	3.5"
Nozzle	0.5 x 80	0.75 x 80	1.00 x 80	1.25 x 80	1.75 x 80	1.75 x 70
Spray Pattern	solid	solid	semi solid	solid	solid	solid
Pump Pressure	180	180	175	175	120	165
Head Setting	6	3	3	10	6.75	7.5
Air Setting	12	11.5	11.5	6	9	9

BURNER MANUFACTURER		Riello				
R-40 Series						
Boiler Model	SG-2	SG-3	SG-4	SG-5	SG-6	SG-7
Burner Model	F-3	F-5	F-5	F-5	F-10	F-10
Firing Rate	0.65	1.00	1.3	1.6	1.9	2.25
Insertion Depth	3 1/2"	5"	5"	5"	4 1/4"	4 1/4"
Nozzle	.55 X 70	.85 X 60	1.00 x 60	1.25 X 60	1.65 X 60	1.75 X 45
Spray Pattern	W	W	W	W	Solid (B)	Solid (B)
Pump Pressure	145 psi	145 psi	175 psi	175 psi	145 psi	165 psi
Turbulator	0.5	1	3	4	2	3
Air Gate	3.2	2.25	3	4	3.75	4.25

8.2 Gas Burner Setup

This page is only for boilers using a gas burner. If an oil burner is being used, please refer to page 12 for the proper setup of the burner.

Riello		Natural Gas					Propane			
Boiler Model	Burner Model	Input (MBH)	Man. Pres. (W.C.)	Head Setting	Air Gate	Orifice (mm)	Man. Pres. (W.C.)	Head Setting	Air Gate	Orifice (mm)
SG-2	R120	91	1.35"	2.0	2.75	1.7	1.35"	2.0	2.75	1.3
SG-3	R200	140	1.14"	3.0	2.4	2.0	1.85"	3.0	2.4	1.3
SG-4	R200	182	1.67"	5.0	3.0	2.0	2.65"	5.0	3.0	1.3
SG-5	R400	224	1.12"	1.0	2.4	2.2	1.37"	1.0	2.5	1.5
SG-6	R400	266	1.25"	2.0	2.8	2.2	1.5"	2.0	2.6	1.5
SG-7	R400	315	1.5"	3.0	3.2	2.2	1.9"	2.0	2.9	1.5

Heat Wise		Natural Gas					Propane			
Boiler Model	Burner Model	Input (MBH)	Man. Pres. (W.C.)	Head Setting	Air Gate	Orifice	Man. Pres. (W.C.)	Head Setting	Air Gate	Orifice
SG-2	SU-2A	91	3.5"	20	closed	7/32"	N/A	N/A	N/A	N/A
SG-3	SU-2A	140	3.5"	15	8.3	9/32"	2.3"	15	8.5	9/32"
SG-4	SU-2A	182	3.5"	9	14	21/64"	2.3"	9	14	21/64"
SG-5	SU-2A	224	3.5"	3	15	27/64"	2.3"	3	15	27/64"
SG-6	SU-3	266	1.7"	1	6	No	1.4"	4	4.75	No
SG-7	SU-3	315	2.5"	3	8.5	No	2.0"	3	9	No

To determine how much gas is coming into the burner, or to set the gas meter correctly, the following formula can be used.

The chart to the right can be used to determine the flow rate depending upon the time per revolution and the size of the gas meter dial.

Seconds per Revolution	Size of Gas Meter Dial (Cubic Foot)		
	0.5	1	2
20	90	180	360
25	72	144	288
30	60	120	240
35	51	103	206
40	45	90	180
45	40	80	160
50	36	72	144
55	33	65	131
60	30	60	120

$$Ft^3/hr = [3600/(sec. Per rev.)] * (Size of gas meter)$$

9. Gas Line Piping

Gas supply piping is to be sized and installed properly in order to provide a supply of gas sufficient to meet the maximum demand without undue loss of pressure between the meter and the boiler. Consult with the **National Fuel Gas Code ANSI Z223.1** for proper sizing of gas piping for various lengths and diameters.

Locate a drop pipe adjacent to, but not in front of the boiler. Locate a tee in the drop pipe at the same elevation as the gas inlet connection to the boiler. Extend the drop line with a nipple towards the floor and cap to form a sediment trap. Install a shut off valve before the tee with sediment trap and a union after the tee before the combination gas valve.

When installing the boiler, make sure a pipe compound resistant to the action of liquefied petroleum is used. Check piping for leaks. Always check leaks with a water and soap solution. **DO NOT USE A FLAME FOR CHECKING GAS LEAKS**

The boiler and its individual shut-off valve must be disconnected from the gas supply piping during any pressure testing of that piping at test pressures in excess of 1/2 psi.

INSTALLATION OF SEDIMENT TRAP AND BURNER SUPPLY LINE

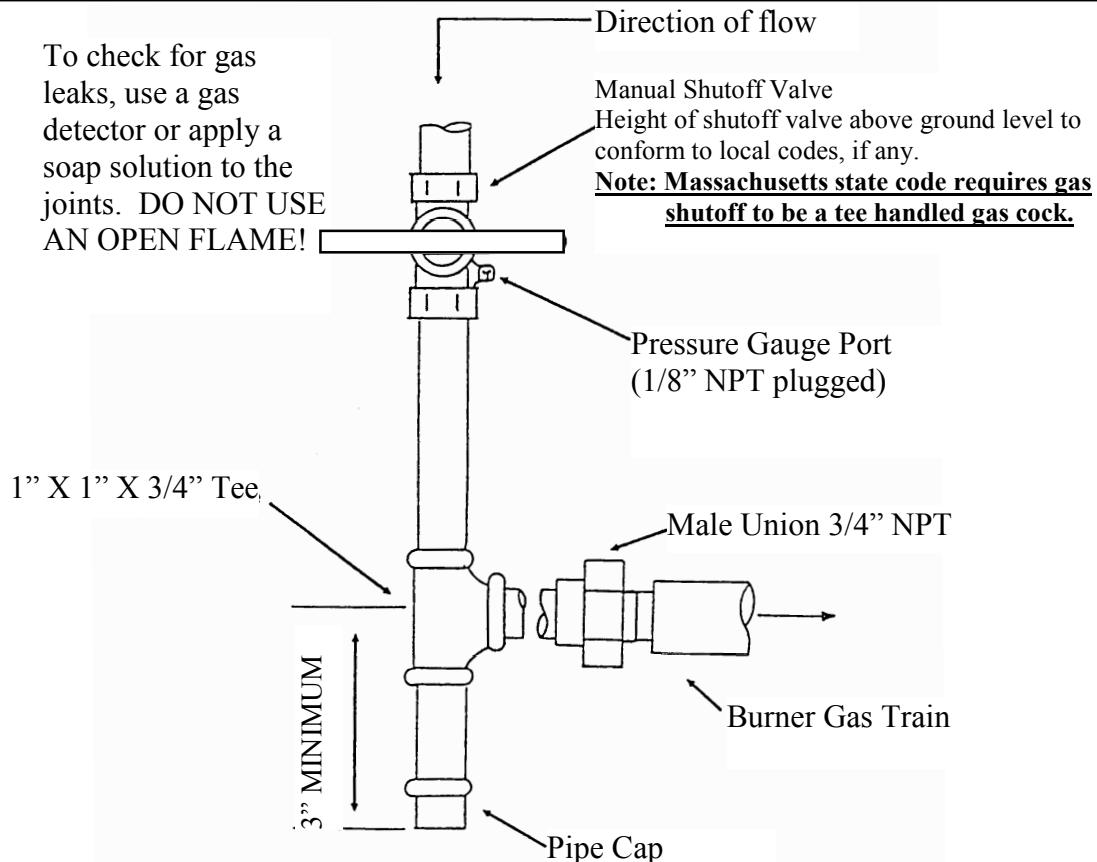

10. Boiler Jacket Assembly

1) Install jacket after installing supply and return piping and installing the breech. After hanging the jacket, install the immersion well for the aquastat and the PRV piping.

2) Wrap the boiler body (1) with insulation (2) and fasten in place with strap provided. Secure the plastic strap use the white plastic buckles (Fig. 10.1) supplied in the casing box.

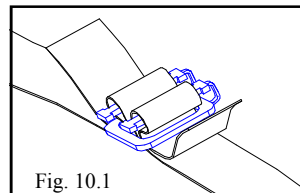

3) Attach the two upper mounting brackets (4) to the upper tie rods using the outer nuts (5) already mounted on tie rods.

4) Attach the two lower mounting brackets (3) to the lower tie rods using the outer nuts (5) already mounted on the tie rods.

5) Mount side panels (6-7) by sliding slit on bottom of panel onto tab on lower mounting bracket (3) and fasten to top mounting bracket (4) using washers and self-tapping screws (14).

6) Insert the control panel (12) between side panels (6-7) and fasten to top mounting bracket (4) through the back of the control panel with the screws supplied (13). Please see next page for installation location of sensor fittings and probes.

7) Fasten the two rear panels (9-10) to the side panels (6-7) with screws supplied (14).

8) Close top of boiler with the cover (8), hooking it to the sides (6-7) in the front and fastening it in the rear with screws (14).

9) Attach front panel (11) of the casing by sliding onto tabs located on bottom of the side panels (6-7), and pushing top of front panel till mounting pins engage.

NOTE: Do not attach any electrical wiring, conduit or boiler piping to the to the front (#11) or top panel (#8) of the casing.

Boiler Components & Parts Biasi SG — Series

Boiler Jacket Assembly:

- 1) Boiler Body
- 2) Insulation Surrounding Boiler
- 3) Lower Mounting Bracket
- 4) Upper Mounting Bracket
- 5) M10 Nut (mounted on tie rod)
- 6) RH Side Jacket Panel
- 7) LH Side Jacket Panel
- 8) Top Jacket Panel
- 9) Top Rear Jacket Panel*
- 10) Bottom Rear Jacket Panel*
- 11) Front Jacket Panel*
- 12) Control Panel
- 13) Self-tapping screw
(min. 3/4" long)
- 14) Self-tapping screw
(min. 1/2" long)

* Supplied with attached insulation

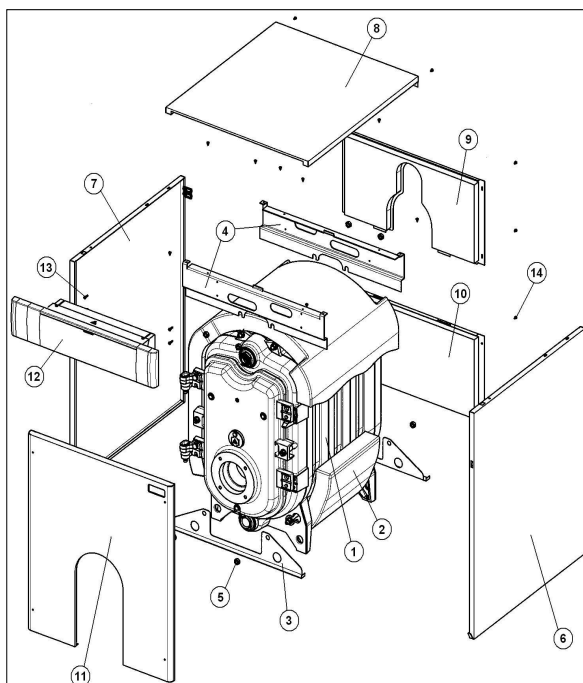

11. Control Panel Sensor installation

1. Install the control panel to the casing bracket as described on the previous page.
2. Insert both the temperature gauge probe and the temperature limit probe from the SG control panel into the immersion well all ready installed in the front of the boiler. **Do not install the 7248 probe into the front immersion well.**
3. Remove spring clip from well and reinstall the clip over the capillary lines for the probe.
4. Install pressure adapter (Part #1) into lower tapping on front of boiler. Be sure not to get any sealant on the adapter end of the fitting.
5. Install the capillary fitting (Part #2) into the pressure adapter.

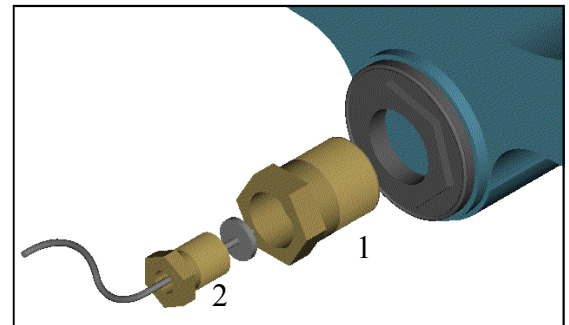
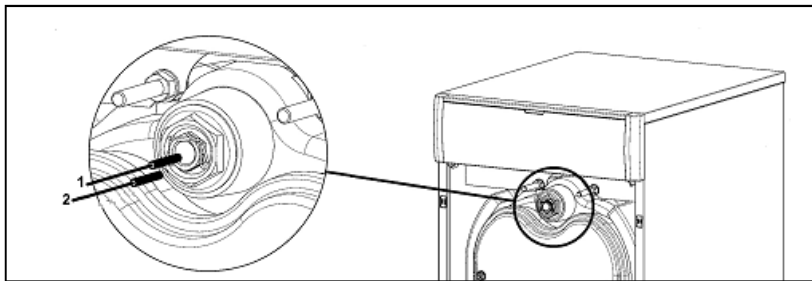

11. Control Panel Legend

1. On/Off Switch
2. Pressure Gauge
3. Temperature Gauge
4. Operating Temperature Control

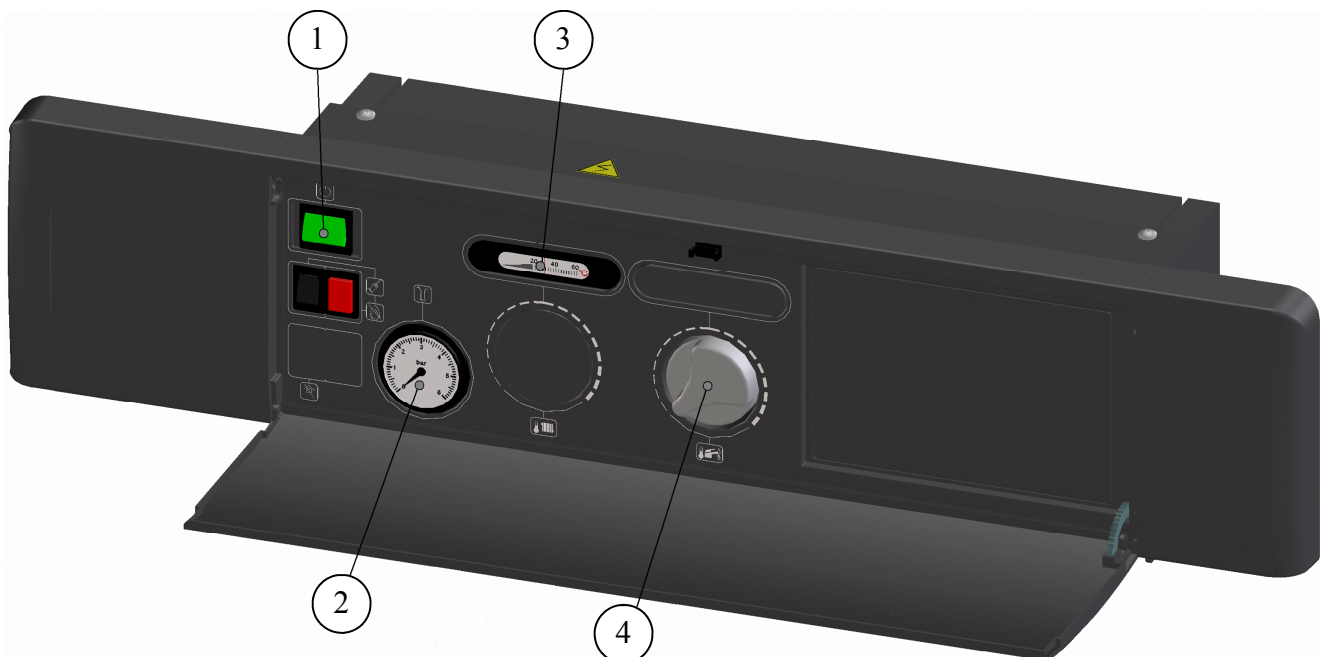

Panel Aquastat Temperature Range

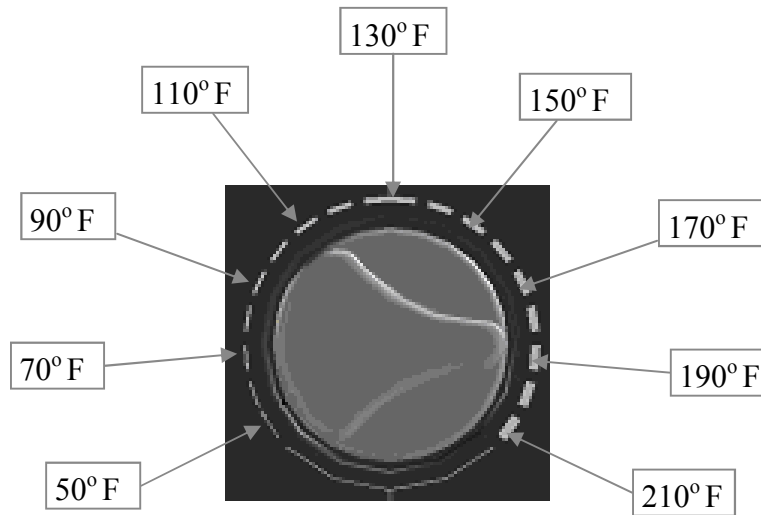

12. Wiring

The electricity to the boiler shall come from a dedicated breaker in the electric service box. A service switch should be mounted on the side of the boiler so the burner technician can service the burner and controls. The electrical wiring should be routed so as not to interfere with normal servicing of the boiler. Wiring done in the field between devices not attached to boiler shall conform with the temperature limitations for type T wire (63F/35C) or other specified wire as applicable when installed in accordance to manufacturer's instructions and wiring diagrams.

If an external electrical source is utilized, the boiler, when installed, must be electrically bonded to ground in accordance with the requirements of the authority having jurisdiction or, in the absence of such requirements, with the National Electrical Code, ANSI/NFPA 70 and/or the Canadian Electrical Code Part 1, CSA C22.1, Electrical Code.

Refer to pages 26 to 28 for oil wiring diagrams and page 29 for gas wiring diagrams.

12. Wiring

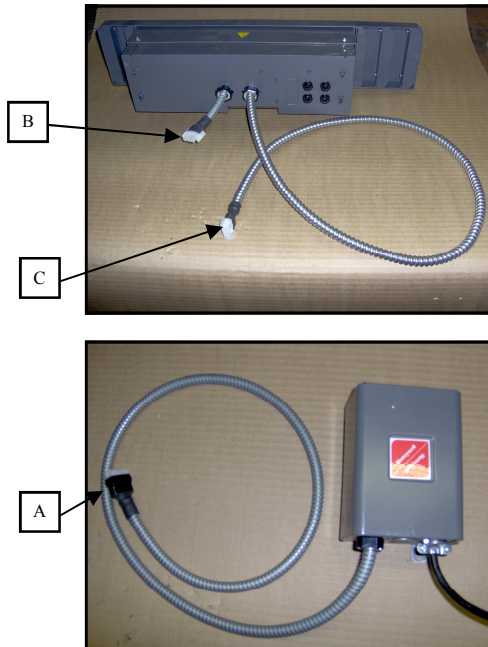

- Mount the 7248 control to the side of the casing in the rear of the boiler. Position the aquastat so that the sensor is able to reach the immersion well installed in the back of the boiler where it will be installed.
- Run wire harness "A" under the top panel of the boiler casing.
- Connect the female connector from harness "A" to the male connector of harness "B".
- Harness "C" connects to the burner. Run the harness behind the front panel of the boiler and connect it to the male harness on the burner.
- Bring line voltage into the power terminals of the 7248 high limit aquastat.
- Connect the "TT" terminals of the 7248 to the end-switch on a external control or to a room thermostat.
- For more detail, please refer to the wiring diagrams on the following pages.

12.1 Oil Burner Wiring

Heat Wise burner/Beckett NX, multi-zone, control wiring with DHW Priority

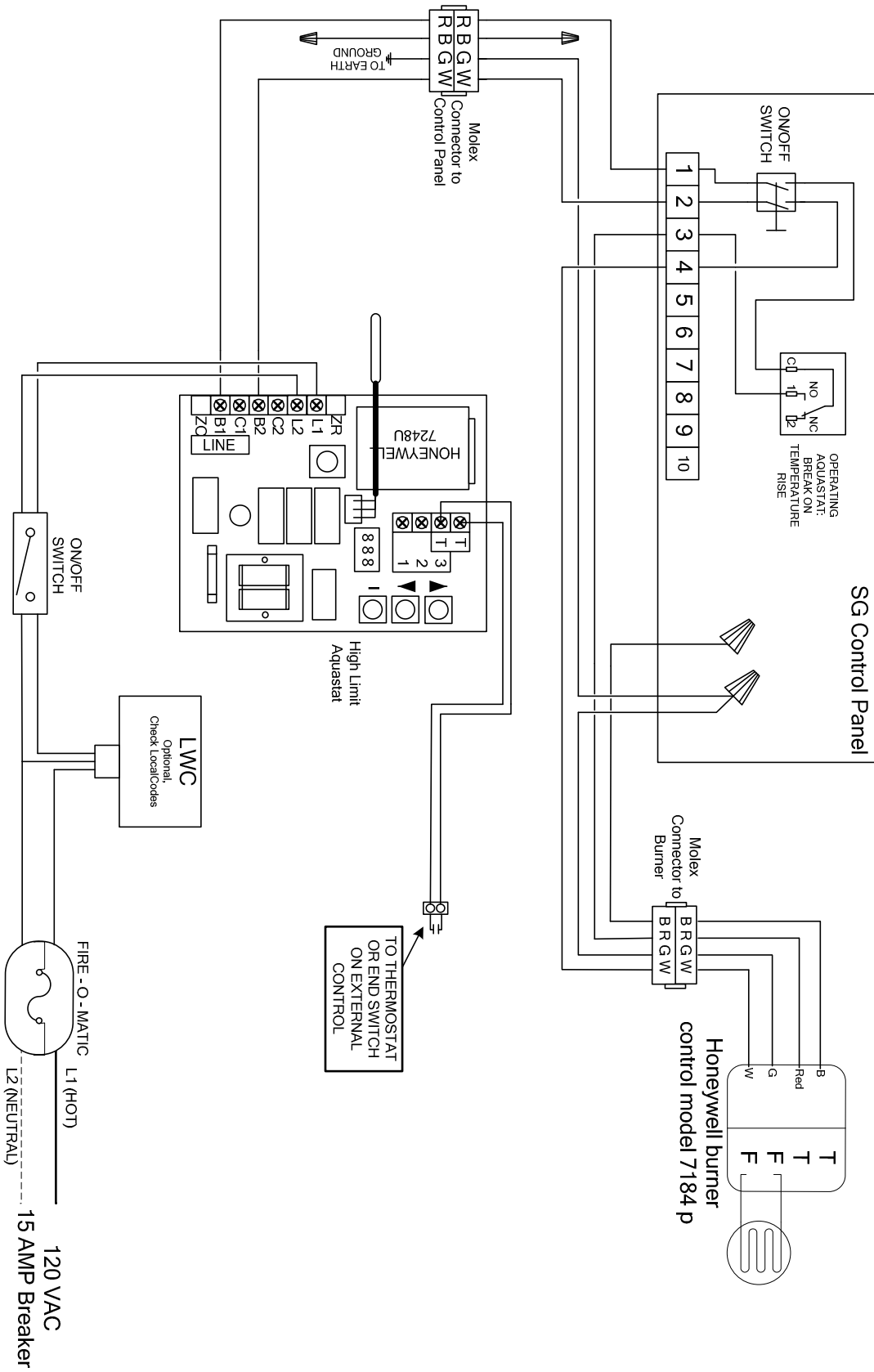

12.1 Oil Burner Wiring

Riello, multi-zone, control wiring with DHW Priority

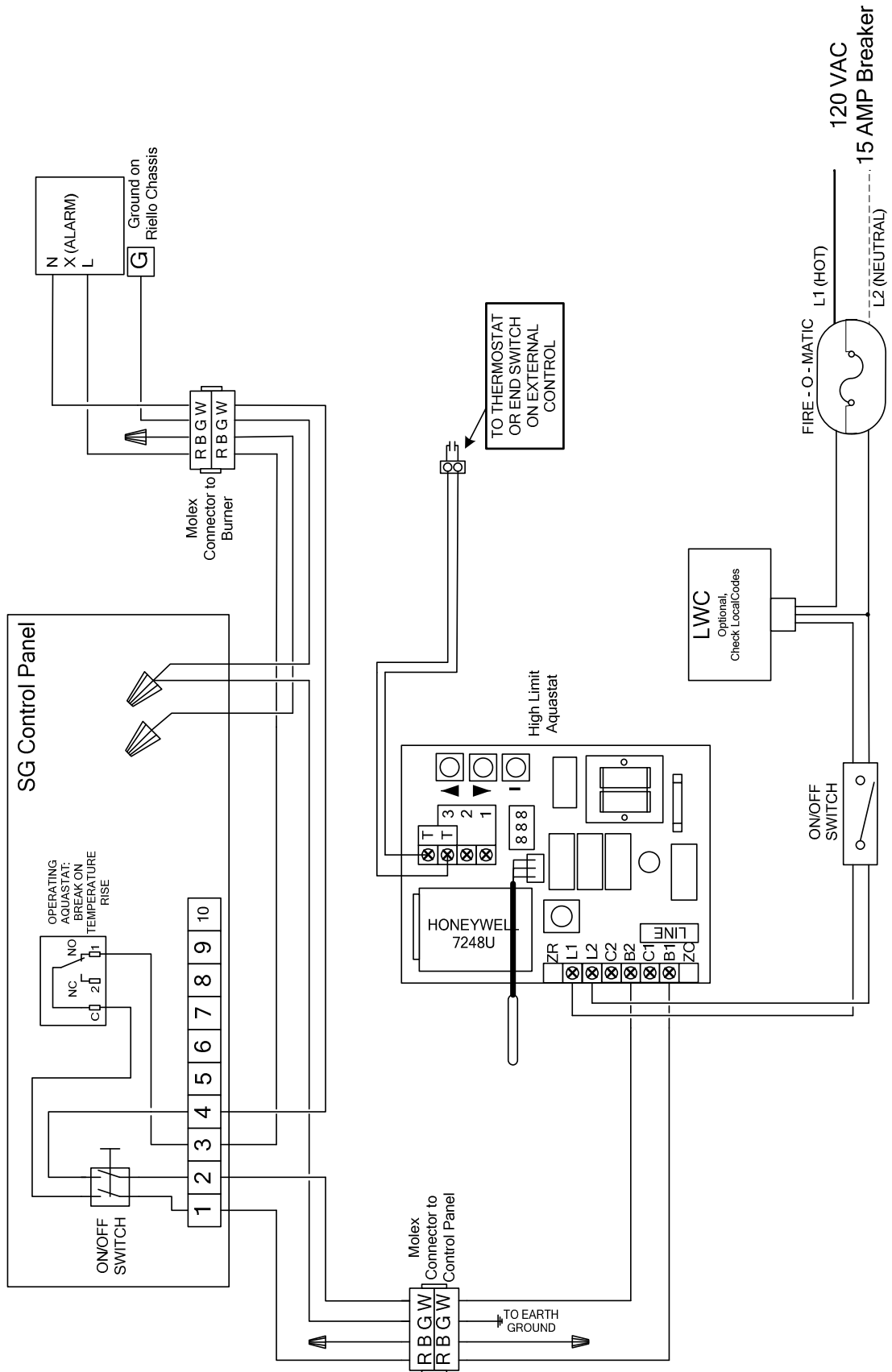

12.2 Gas Burner Wiring

Riello Gas burner, multi-zone, single stage, control wiring

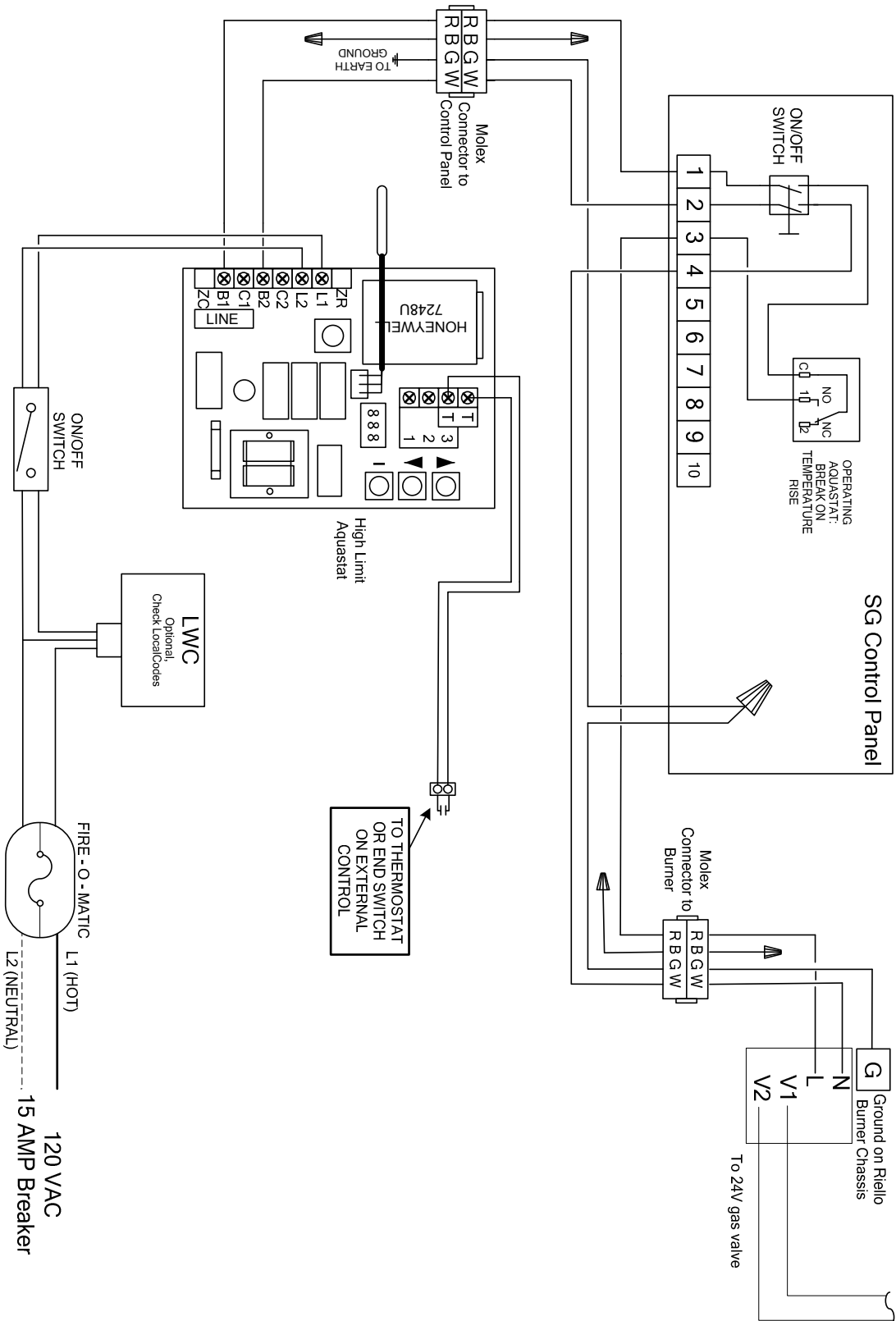

12.2 Gas Burner Wiring

Heat Wise SU-2A Gas burner, multi-zone, control wiring with DHW priority

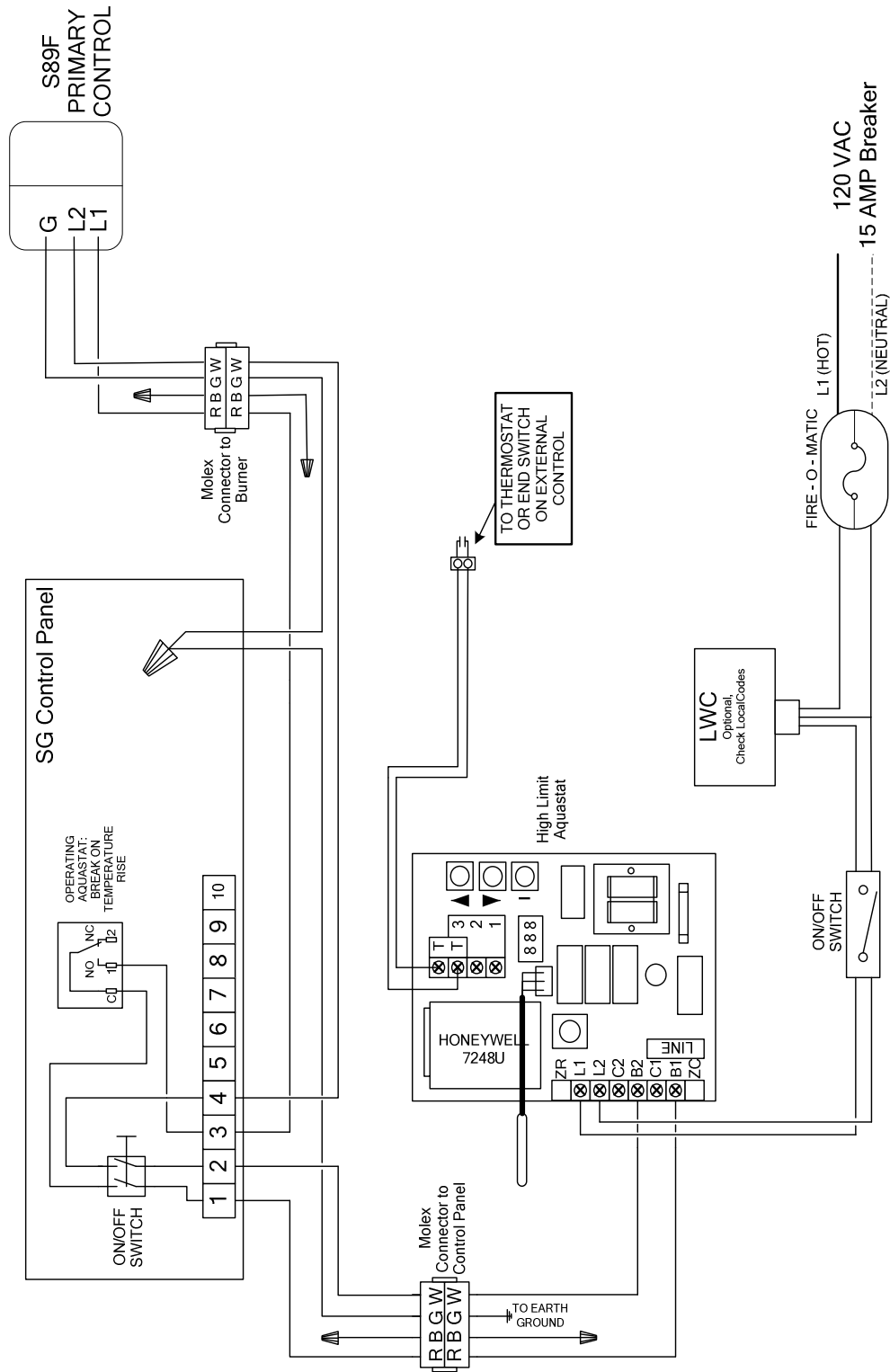

13. SG Efficiency Control

The SG boiler is available with an efficiency control. The control is installed into the SG control panel from the factory. It is pre wired and uses the same quick connections as the standard control panel. Installation of the SG efficiency control panel is the same as the standard control panel. Please follow the steps on page 23. Please follow the additional steps below to complete the installation.

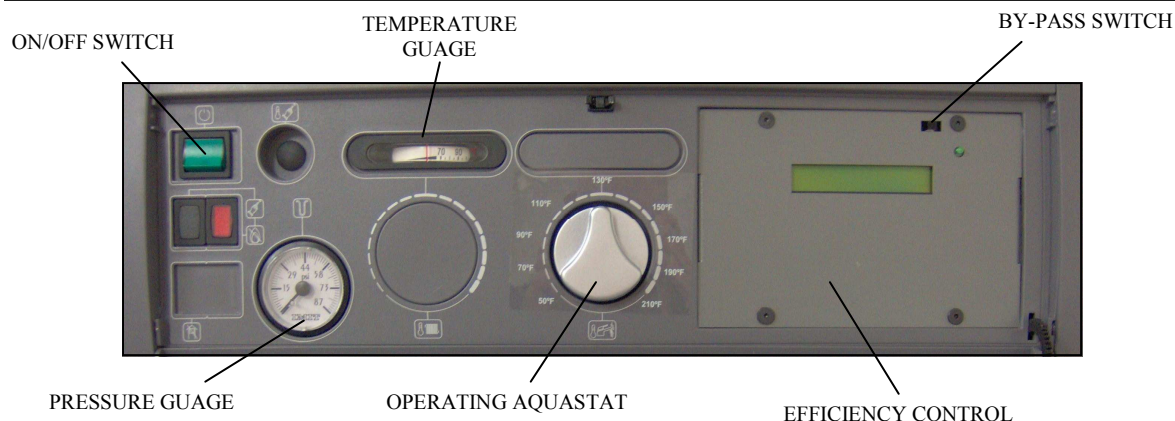

13.1 Programming

The following parameters may be changed in the field by following these instructions.

Pre-purge time, Degrees F or C, Heating Water Low-Limit, Domestic Water Low-Limit, Maximum Hold Off Time, Standby Time Override, Economizing Time and Run Time Display.

It is very important that if there is any kind of a delay (more than fifteen seconds), from the time that the Operating-control calls for the burner to start and the burner actually starts, that this time delay value be entered into the controller as a Pre-Purge time (e.g. actual pre-purge timer, Flue Damper interlock, etc.). If there is a delay and the correct value is not programmed into the controller, the savings calculations will be incorrect.

All programming is achieved by inserting and removing a water temperature sensor into the DOM SENSOR connector, when directed to do so via the display on the controller. The sensor must be connected to the cable or this will not work!

1. Turn all power to the boiler off. Remove the front and top panels from the boiler. Remove the two screws from the top of the SG control panel and swing the face of the panel open. You will now be able to see the efficiency control.
2. Remove the sensor wire from the heat sensor port and insert it into the domestic sensor port. Make sure that the sensor is unplugged from the other end of the sensor wire. Return the control panel to the closed position.

13.1 Programming

3. Power up the boiler. When prompted, insert the sensor wire into the jack on the temperature sensor. To confirm, remove the plug when prompted. The unit will then indicate that it has entered “**Config Mode**”. After a four second delay the control will advance to the first programmable parameter. You can leave the programming mode at any time by turning the power off to the control.
4. Parameters will be set by removing and inserting the sensor wire into the jack on the sensor. Follow the prompts on the screen to proceed through the settings. All settings that are available are shown below.

SETTINGS

	DEFAULT	RANGE	
RESET DEFAULTS	N/A	N/A	Resets control to default settings
RESET SAVINGS	N/A	N/A	Clears Average Savings calculator
RESET ECON TIMER	N/A	N/A	Clears Economizer accumulator
RESET RUN-TIME	N/A	N/A	Clears the Run-Time accumulator
PREPURGE= xxx SEC	4	N/A	Prepurge time for power burner
DEGREES C OR DEGREES F	F	F or C	Changes scale that control reads in
HLOLIM = xxx F	120	90 - 160	Sets the low-limit water temperature for the heating water
DLOLIM = xxx F	115	90 - 150	Sets the low-limit water temperature for the domestic water
MAX ECON = xxx MIN	45	10 - 120	Sets the maximum amount of time control will remain in economizer mode.
ECON TIMER OFF OR ECON TIMER ON	ON	ON or OFF	Controls whether the Economizer accumulator timer is displayed or not
RUN TIME OFF OR RUN TIME ON	ON	ON or OFF	Controls whether the Run-Time accumulator timer is displayed or not
MAX STDY = xxx MIN	DISABLE	45 - 180/DISABLED	Sets the maximum amount of time the control will remain in standby

4. Once you have completed programming your control, turn the power to the boiler off. Open the face of the SG control panel again by removing the two screws on the top of the panel. Switch the sensor wire on the efficiency control from the domestic water sensor port to the heating water sensor port. Close the SG control panel and replace the top and front panels of the casing. Turn power to the boiler back on and mount the sensor for the efficiency control to the supply pipe of the boiler. Please see the next section for details on mounting the sensor.

13.3 Sensor Installation

The sensor for the SG efficiency control should be installed on the boiler supply pipe of the boiler. It should be positioned as shown in the illustration below and fixed in place with tyraps. Once the sensor is in place, it is advisable to insulate the sensor with pipe insulation.

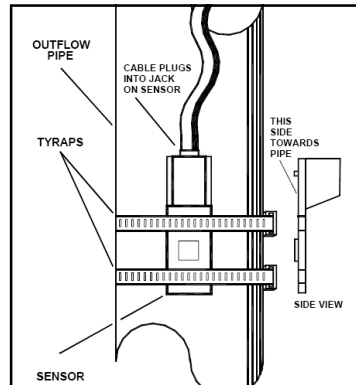

13.4 Efficiency Control Wiring

Wiring SG Control Panel with Efficiency Control

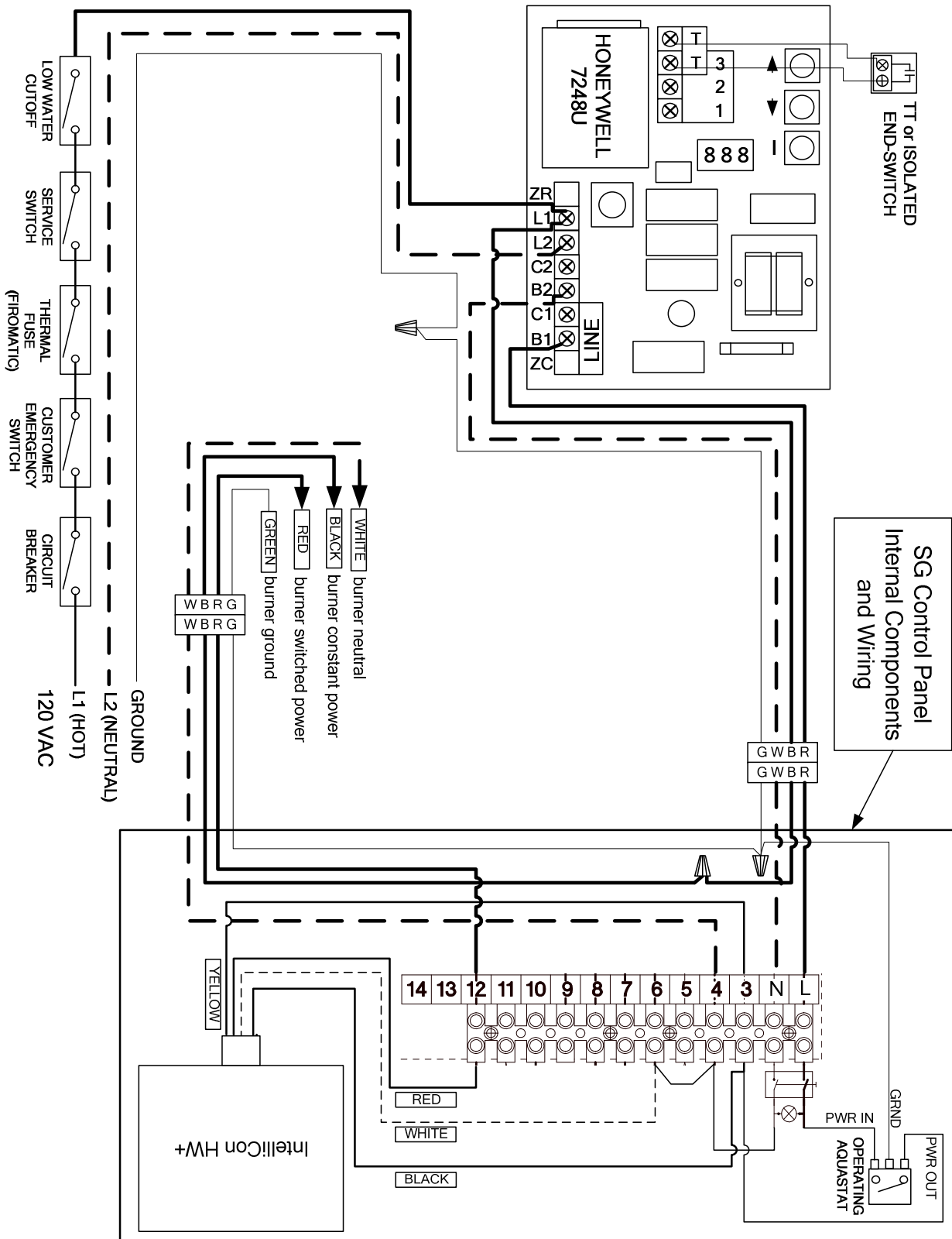

14. Commissioning

Before a gas boiler may be commissioned, it's gas connection must be leak tested before the boiler may be put into operation and tested. After installation of oil/gas-fired boiler, operation and performance tests shall be conducted to make certain that the burner is operating in an acceptable manner and that all safety controls and devices function properly. It is critical that the high limit, low water cutoff and burner "cad cell" relay be checked for normal operation before leaving the job.

CAUTION

Label all wires prior to disconnection when servicing controls. Wiring errors can cause improper and dangerous operation.

15. Maintenance

The Biasi boiler system should be serviced once a year.

1. Inspect the boiler and make sure it is operating normally, I.e. temperature and pressure.
2. Inspect the Pressure Relief Valve and manually set it off three times to ensure it is operating normally and not leaking.
3. If a Low Water Cut-Off is installed follow the manufactures suggested maintenance and test procedures.
4. Adjust room thermostat so there is a call for heat and test boiler high limit for proper operation.
5. Turn boiler safety switch off.
6. Open lower swing door and remove upper clean out plate.
7. Brush upper passages first and then clean combustion camber of any debris with brush and vacuum.
8. Remove smoke pipe and clean out debris from cleaning or soot build up.
9. Inspect smoke pipe for any corrosion before reinstalling. Replace if necessary.
10. Consult the burner manufacturers manual for annual maintenance of the burner.
11. Remove all combustible materials from around boiler and ensure the area is free of debris so the burner has adequate intake air supply.

Notice

Verify proper operation after servicing.

16. Installer Notes

System Checkout:

Boiler Model No. _____ Serial No. _____

Original Purchaser: _____ _____ _____	Installer: _____ _____ _____
--	---------------------------------------

Burner Manufacturer-----	Type of Oil Burner-----
Burner Model No.-----	Burner Serial No.-----
Nozzle Manufacturer-----	Nozzle Spray Angle-----
G.P.H. -----	Type -----

Burner Performance Tests:

GROSS STACK TEMPERATURE -----

ROOM TEMPERATURE (AMBIENT) -----

NET STACK TEMPERATURE -----

CO2 -----

O2-----

SMOKE READING -----

COMBUSTION EFFICIENCY-----

COMMENTS _____

17. Homeowner Information

- 1) STOP! Read the safety information on the side of the boiler. DO NOT START THE BOILER UNLESS ALL CLEANOUT DOORS ARE SECURED AND SEALED.

(Skip to step 9 for oil burning boilers)

- 2) Set thermostat to lowest setting
- 3) Turn off all electric power to the appliance
- 4) Do not attempt to light the burner by hand
- 5) Turn the manual shut off on the combination gas valve clockwise to the off position.

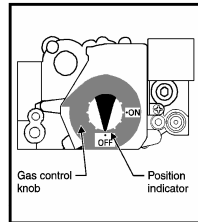

- 6) Wait five minutes to clear out any gas. Then smell for gas, including near the floor. **If you smell gas, STOP!** Follow “B” in the safety information above on this label. If you don’t smell gas, go to the next step.
- 7) Return the manual valve on the combination gas valve to the on position by reversing step “5”.
- 8) Turn on all electric power to the appliance.
- 9) Set thermostat to the desired setting.
- 10) If the burner fails to light you may press the reset button once. If the appliance will not operate, follow the instructions “To Turn Off Gas To Appliance” and call your service technician or gas supplier. DO NOT ATTEMPT TO START THE BURNER WHEN EXCESS OIL HAS ACCUMULATED, WHEN THE UNIT IS FULL OF VAPOR, OR WHEN THE COMBUSTION CHAMBER IS VERY HOT.

NOTE: ALWAYS KEEP THE MANUAL FUEL SUPPLY VALVE SHUT OFF IF THE BURNER IS SHUT DOWN FOR AN EXTENDED PERIOD OF TIME.

TO TURN OFF GAS APPLIANCE

- 1) Set the thermostat to the lowest setting.
- 2) Turn off electric power to the appliance if service is to be performed.
Turn the gas control valve to the off position.

Warranty For BIASI SG Series Residential Cast-Iron Water Boilers

FIRST YEAR-WARRANTY FOR SG SERIES RESIDENTIAL HOT WATER BOILERS: QHT warrants that its cast-iron boiler and casing are free from defects in material and workmanship for one year from the date of installation. If the boiler is found to be defective within this period, QHT will replace the boiler block or casing.

LIFETIME WARRANTY-WARRANTY FOR THE CAST IRON BOILER BLOCKS OF THE SG SERIES RESIDENTIAL BOILERS: Biasi warrants that the cast-iron sections and nipples of the BIASI SG boilers are free from defects in material and workmanship for the lifetime of the original single family home installation. If the SG boiler block is then found to be defective, QHT and Biasi will replace the original cast iron boiler block.

These warranties are subject to the condition that a heating contractor whose principal occupation is the sale and installation of heating equipment must have installed the boiler.

PARTS, WHICH ARE COVERED, consists of all materials supplied by Biasi, identified by QHT's part numbers in its literature. Other parts supplied in the casing, trim kit or in the burner pack carry their own warranty and each manufacturer has responsibility for its own products.

NOTE: ANY PART, WHICH IS REPLACED UNDER WARRANTY, CARRIES ONLY THE UNEXPIRED PORTION OF THE ORIGINAL WARRANTY.

OWNER RESPONSIBILITIES:

1. Provide for proper installation, which includes pressure relief and pressure reducing valves and high limit safety controls on closed systems.
2. Provide qualified periodic service to prolong proper operation and service.
3. Insure that boiler is installed with approved burner and that installation conforms to all codes and ordinances.
4. This warranty does not apply to boilers, which are subject to misuse, abuse, neglect, alteration, accident, excessive temperature, excessive pressure, or corrosive water or atmosphere.
5. Owner will be responsible for return of faulty components to Portsmouth, NH, freight pre-paid.

QHT and Biasi will not be responsible for:

1. Components that are part of the heating system, but were not manufactured by Biasi or QHT as part of the boiler.
2. The workmanship of the installers of SG boilers. Furthermore, this warranty does not assume any liability for unsatisfactory performance caused by improper installation.
3. Any costs for labor to remove or replace the faulty component.
4. Improper burner application or adjustments, control settings, care or maintenance.
5. Any damage associated with corrosion or leakage due to the use of "non-barrier", plastic pipe in the heating system.

*THIS WARRANTY DOES NOT EXTEND TO ANYONE EXCEPT THE FIRST PURCHASER AT RETAIL AND ONLY WHEN THE BOILER IS IN THE ORIGINAL INSTALLATION SITE.

*IMPLIED WARRANTIES OF FITNESS FOR A PARTICULAR PURPOSE AND MERCHANTABILITY SHALL BE LIMITED TO THE DURATION OF THE EXPRESSED WARRANTY. BIASI AND QHT EXPRESSLY DISCLAIM AND EXCLUDE ANY LIABILITY FOR CONSEQUENTIAL OR INCIDENTAL DAMAGES FOR BREACH OF ANY EXPRESSED OR IMPLIED WARRANTY.

THIS WARRANTY GIVES YOU SPECIFIC LEGAL RIGHTS, AND YOU MAY HAVE OTHER RIGHTS THAT VARY FROM STATE TO STATE.

For prompt warranty service, notify the installer, who, in turn, will notify the distributor from whom he purchased the boiler. If this does not result in corrective action, contact Biasi through Quincy Hydronic Technologies (Address Below) with details in support of the warranty claim. All claims must be processed through proper trade channels. Contact with Biasi directly is not recommended for rapid claim settlement.

Quincy Hydronic Technologies,
3560 Lafayette Rd.
Portsmouth, NH, 03801
Tel. (603) 334-6400

Manufactured by:
BIASI S.p.A.
Verona, Italy