

## INSTALLATION, OPERATING AND MAINTENANCE MANUAL

WALL-MOUNTED GAS  
CONDENSING WATER  
HEATERS

# AGUADENS

# INDEX

1 - GENERAL SAFETY RECOMMENDATIONS .....	4
1.1 - National laws and regulations .....	5
2 - GENERAL INFORMATION .....	6
2.1 - Presentation .....	6
2.2 - Model overview .....	6
2.3 - Manufacturer .....	7
2.4 - Symbols key .....	7
2.5 - Maintenance .....	7
3 - MAIN COMPONENTS .....	8
4 - OPERATION .....	12
4.1 - Operation and intended use of the appliance .....	13
4.2 - Examples of installation .....	14
5 - INSTALLATION .....	16
5.1 - Opening the packaging .....	16
5.2 - Dimensions and minimum safety clearances .....	16
5.3 - Choosing suitable installation location .....	16
5.4 - Mounting the appliance .....	16
5.5 - Domestic hot and cold water .....	16
5.6 - Gas .....	17
5.7 - Condensate drain .....	18
5.8 - Safety valve .....	18
5.9 - Hydraulic and gas connections .....	19
5.10 - Water softener (on request) .....	19
5.11 - Electrical connections .....	20
5.11.1 - Power supply cable connection .....	21
5.11.2 - CR04 remote Time control (on request) .....	21
5.12 - External secondary return configuration .....	22
5.13 - Connection water heater to Storage tank .....	23
5.13.1 - Anti- legionella precaution .....	23
5.14 - Flue systems .....	25
5.14.1 - Exhaust flue with independent combustion air grille type B23 .....	26
5.14.2 - "Split 80/80PP" System (polypropylene) (Type C43; C53; C83) AGUADENS 16 and 22 .....	27
5.14.3 - "Split 80/80PP" System (polypropylene) (Type C43; C53; C83) AGUADENS 37 .....	28
5.14.4 - "Split 80/80PP" System (Type C43; C53; C83): accessories available .....	29
5.14.5 - "Split 80/80PP" System (Type C43; C53; C83): installation examples .....	30
5.14.6 - "60/100PP vertical coaxial" System (polypropylene) (C13; C33 Type) .....	31
5.14.7 - "60/100PP horizontal coaxial" System (polypropylene) (C13; C33 Type) .....	32
5.14.8 - "60/100PP Coaxial" System: accessories available .....	33
5.14.9 - "60/100PP Coaxial" System: installation examples .....	34
5.14.10 - "80/125PP vertical coaxial" System (polypropylene) (C13; C33) .....	35
5.14.11 - "80/125PP Coaxial" System: accessories available .....	36
5.14.12 - "80/125PP Coaxial" System: installation examples .....	37
6 - OPERATING .....	38
6.1 - Operating .....	38
6.1.1 - User instructions .....	38
6.1.2 - Filling the condensate drain siphon .....	38
6.2 - General recommendations regarding the supply of gas .....	38
6.3 - Type of gas for which the appliance is regulated .....	39
6.4 - Conversion of the appliance from one type of gas to another .....	39
6.5 - Ignition .....	41
6.6 - Check the gas supply pressure .....	41
6.7 - Measurement and adjustment of CO2 levels .....	42
6.8 - Self-learning and calibration of the minimum and maximum capacity output .....	43
6.9 - Adjust the domestic hot water flow rate .....	43
6.10 - Check the capacity input .....	43
7 - USE .....	44
7.1 - Display .....	44
7.2 - Ignition procedure .....	44
7.3 - "User menu" .....	45
7.4 - Adjustment of the domestic hot water temperature .....	45
7.5 - Timings of the various functions .....	45
7.6 - Display Energy Saving mode .....	45

# INDEX

---

7.7 - "User menu" Parameters.....	46
7.8 - "Installer menu" & parameters.....	47
7.9 - Diagnostics.....	48
7.9.1 - Diagnostics "Loc" block fault codes and potential solution .....	49
7.9.2 - Diagnostics "E" error fault codes and potential solutions.....	51
7.10 - Switch ON and OFF the appliance.....	52
8 - MAINTENANCE .....	53
8.1 - Care and maintenance.....	53
8.1.1 - Service recall .....	53
8.1.2 - Address reported problems.....	53
8.1.3 - Check all piping for gas leaks .....	53
8.1.4 - Verify flue and air lines in good condition and sealed tight; .....	53
8.1.5 - Check system water pressure/system piping/expansion tank; .....	53
8.1.6 - Check control settings.....	53
8.1.7 - Check wiring and connections .....	54
8.2 - Casing removal .....	54
8.3 - Burner and fan removal.....	55
8.3.1 - Thermal insulations.....	55
8.4 - Gas burner and heat exchanger outer surface cleaning procedure.....	55
8.5 - Condensate siphon cleaning procedure.....	57
8.6 - Ignition and flame ionising electrode position.....	58
8.7 - Circulation pump replacement procedure .....	58
8.8 - Domestic water flow meter replacement procedure.....	59
8.9 - Safety valve replacement procedure.....	59
8.10 - Procedure for draining the water heater.....	60
8.11 - Fan test mode procedure .....	60
8.12 - Gas burner minimum and maximum performance test mode procedure.....	60
8.13 - Checking the ionisation current.....	61
8.14 - Water temperature measurement sensor testing procedures.....	61
8.15 - Operational wiring diagram .....	62
8.16 - Multi-wire wiring diagram .....	64
9 - TECHNICAL DATA .....	66
10 - COMMAND MENU DIAGRAM.....	67
11 - ENGINEERS TEST MODE.....	68
12 - CE DECLARATION OF CONFORMITY .....	69

# 1 - GENERAL SAFETY RECOMMENDATIONS

## If you smell gas

1. - Close the gas cock.
2. - Ventilate the room.
3. - Do not switch on any electric device, telephone included.
4. - From another room, call a professionally qualified technician immediately or the gas supply company. Call the Fire Service if the former are not available.

## If you can smell combustion products

1. - Switch the appliance off.
2. - Ventilate the room.
3. - Call a professionally qualified technician.

## Explosive or highly flammable products

Do not store or use explosive or highly flammable materials such as paper, solvents, paints, etc...in the same room where the appliance is installed.

## Installation, modifications

- ☞ The gas appliance must be installed, calibrated or modified by professionally qualified staff, in compliance with National and local Standards, as well as the instructions in this manual.
- ☞ Incorrect installation or poor maintenance can cause injury/damage to persons, animals or objects, for which the manufacturer cannot be deemed liable.
- ☞ The appliance must be connected to an approved flue system. Failure to comply with this regulation can lead to serious risks for people and animals
- ☞ A domestic hot water temperature level exceeding 51°C can cause permanent injury/damage to people, animals and objects. Special care should be taken to protect children, the elderly and those with special needs using non-accessible blending valves to limit the flow hot water temperature at outlets.
- ☞ The water heater flue system must not be modified by unqualified person.
- ☞ The flue system terminals should not be obstructed in any way.
- ☞ Do not leave parts of the packaging and any replaced parts within the reach of children.
- ☞ Seal the adjustment devices after every calibration.
- ☞ In agreement with the provisions for use, the user must keep the installation in good working order and guarantee reliable and safe operation of the appliance.
- ☞ We also highlight the importance of an annual scheduled maintenance contract with a professionally qualified technician.
- ☞ The end user must have maintenance performed on the appliance only by professionally qualified technicians in accordance with this manual and in full compliance with both local and national standards.
- ☞ Before performing any cleaning or maintenance, disconnect the appliance from the mains power supply.
- ☞ After having performed any cleaning or maintenance works, make sure that all internal etc.
- ☞ This appliance is not intended for use by persons (including children) with reduced physical and sensory conditions or lack of experience and knowledge, unless they have been given supervision or instruction concerning use of the appliance by a person responsible for their safety.

- ☞ This manual is an integral and essential part of the product and must be kept carefully by the user, for possible future consultation. If the appliance must be transferred or if you should move and leave the unit to another user, always ensure that this manual remains with the new user and/or installer.

- ☞ Any accessories or kits which might be added must be original Cosmogas products.

- ☞ This appliance must be intended only for the use for which it has been expressly declared: production of domestic hot water for civilian use.

- ☞ Any contractual and extra contractual liability of the manufacturer is excluded for damage caused by installation errors or errors in use and however due to failure to comply with the instructions given by the manufacturer or by failure to comply with applicable national and/or local laws.

- ☞ For safety reasons and respect for the environment, the packaging elements must be disposed of in the relevant separate waste collection centres.

## In case of breakdown

In the case of appliance breakdown and/or malfunctioning, deactivate it and do not attempt any repairs. Contact a professionally qualified technician only. If components must be replaced for repair to be successful, only use original spare parts. Failure to comply with the above can jeopardise the safety of the appliance.

## Professionally qualified technician.

Professionally qualified technicians with certified training covering gas boilers and/or gas water heaters as envisioned by the law.

## Technical drawings

All drawings in this manual relating to electrical wiring, hydraulic and gas layouts are purely indicative. The external services such as electrical cable types and sizes, water services pipes and gas services must always be checked by a professionally qualified technician or engineer to verify compliance with all relevant standards, Laws and codes of good practice.

## Carbon Monoxide.

Every year deaths and serious injuries occur due to carbon monoxide poisoning. This tragedies are avoidable if certain preventative measures such as the following are undertaken:

- ☞ Ensure that all boilers, water heaters, room heaters, stoves and hobs which burn oil, natural gas, LP gas, coal, peat, wood and wood pallets are serviced regularly. Servicing is needed at least once per year to ensure safety. the service person should be qualified and trained to service the specific types of appliance

- ☞ If an appliance is fitted in a dwelling, then a carbon monoxide detector should always be fitted. There are two types available: a simple detector works like a fire alarm to emit a loud noise and flashing light if carbon monoxide is detected or a more sophisticated version which will also switch off the appliance to provide more safety.



# 1 - GENERAL SAFETY RECOMMENDATIONS

## 1.1 - National laws and regulations

- M.D. n°37 dated 22/01/2008 (former Law n°46 dated 05/03/90)
- Law n°10 dated 09/01/91
- Presidential Decree n°412 dated 26/08/93
- Presidential Decree n°551 dated 21/12/99
- Legislative Decree n° 192 dated 19/08/05
- Legislative Decree n° 311 dated 29.12.06
- UNI 7129 Standard
- UNI 7131 Standard
- UNI 11071 Standard
- IEC 64-8 Standard

All the gas appliances must be installed by a competent and qualified person, in accordance with relevant clauses of applicable standards and recommendations. These include but may not be limited to the following:

- I.S. 813 Domestic gas installations.
- I.S. 820 Non-Domestic gas installations.
- IEE Wiring Regulations.
- BS 5546:2010 - Specification for installation and maintenance of gas-fired water-heating appliances of rated input not exceeding 70 kW net.
- BS 5440-2:2009 - Flueing and ventilation for gas appliances of rated input not exceeding 70 kW net (1st, 2nd and 3rd family gases) specification for the installation and maintenance of ventilation provision for gas appliances.
- BS 6644:2011 - Specification for the installation and maintenance of gas-fired hot water boilers of rated inputs between 70 kW (net) and 1.8 MW (net) (2nd and 3rd family gases).
- BS 6891:2005+A2:2008 - Installation of low pressure gas pipework of up to 35 mm (R1 1/4) in domestic premises (2nd family gas) specification.
- BS 5482-1:2005 - Code of practice for domestic butane and propane gas burning installations. Installations at permanent dwellings, residential park homes and commercial premises, with installation pipework sizes not exceeding DN 25 for steel and DN 28 for corrugate stainless steel or copper.
- BS 5482-2:AMD 12046: June 2001 - Domestic butane and propane gas burning installations. Installations in caravans and non-permanent dwellings.
- BS 5482-3:2005 - Domestic butane and propane gas burning installations. Installations in boats yachts and other vessels.
- Building regulations issued by Department of the Environment and Building Standards Regulations.
- Gas safety (Installation and Use) Regulations current issue.
- BS 6700 - Design, installation, testing and maintenance of services supplying water for domestic use within buildings and their cartilages - Specification.
- UK Health and safety at work Act.

- All relevant Building Regulations.
- Local Water Bye Laws.
- Water Regulations.
- Health & Safety legislation.

Failure to install this appliance correctly could lead to prosecution. It is your own interest and that of safety to ensure that the law is complied with. Manufacturer's instructions must not be interpreted as over-riding statutory obligations under any circumstances.

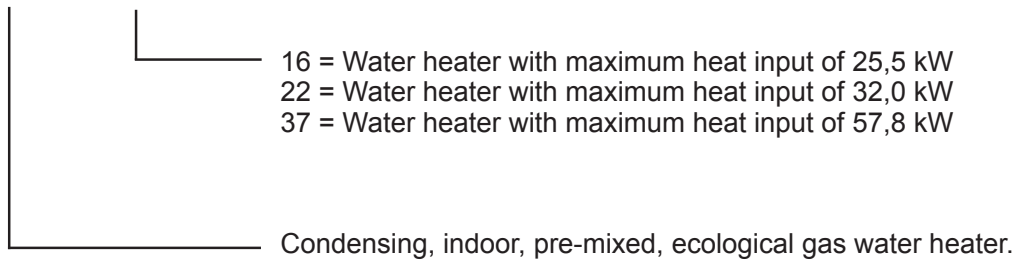


### 2.1 - Presentation

Congratulations! You have purchased one of the best products on the market. Each individual part is proudly designed, produced, tested and assembled within the COSMOGAS establishment, thus guaranteeing the best quality control.

### 2.2 - Model overview

#### AGUADENS XX



### 2.3 - Manufacturer

COSMOGAS srl  
Via L. da Vinci 16  
47014 - Meldola (FC) Italia  
Tel. 0543 498383  
Fax. 0543 498393  
www.cosmogas.com  
info@cosmogas.com

### 2.4 - Symbols key



#### ATTENTION !!!

Electric shock hazard. Failure to comply with these recommendations can jeopardise the good working order of the appliance or cause serious damage to persons, animals or objects.



#### ATTENTION !!!

General hazard. Failure to comply with these recommendations can jeopardise the good working order of the appliance or cause serious damage to persons, animals or objects.

 Important indication symbol.

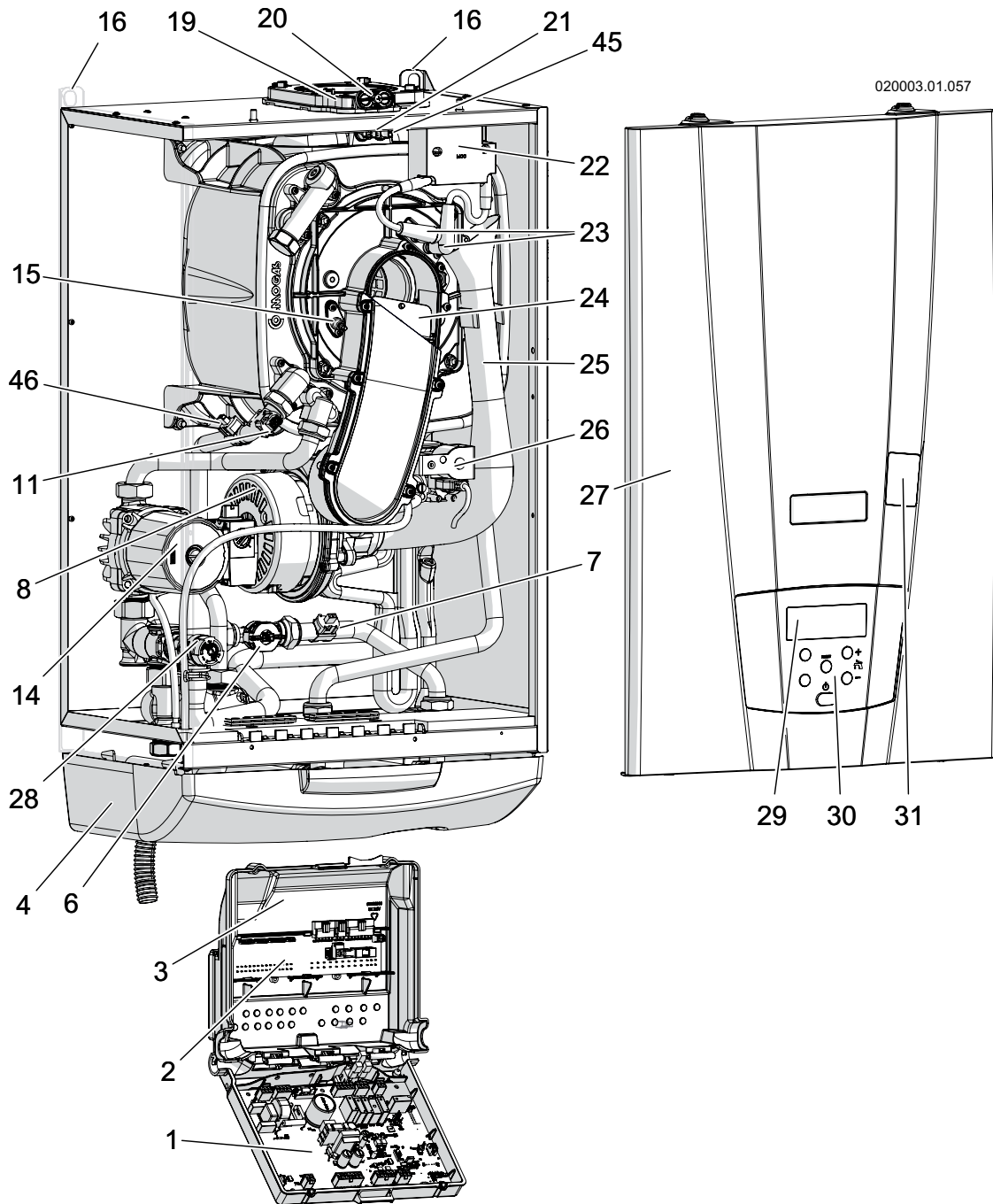
### 2.5 - Maintenance

It is recommended to perform regular yearly maintenance of the appliance for the following reasons:

- to maintain a high yield and manage the domestic hot water plant economically (with low fuel consumption);
- to achieve a high level of safety;
- to maintain the level of environmental compatibility of the combustion high;

Offer your customer a scheduled maintenance contract.

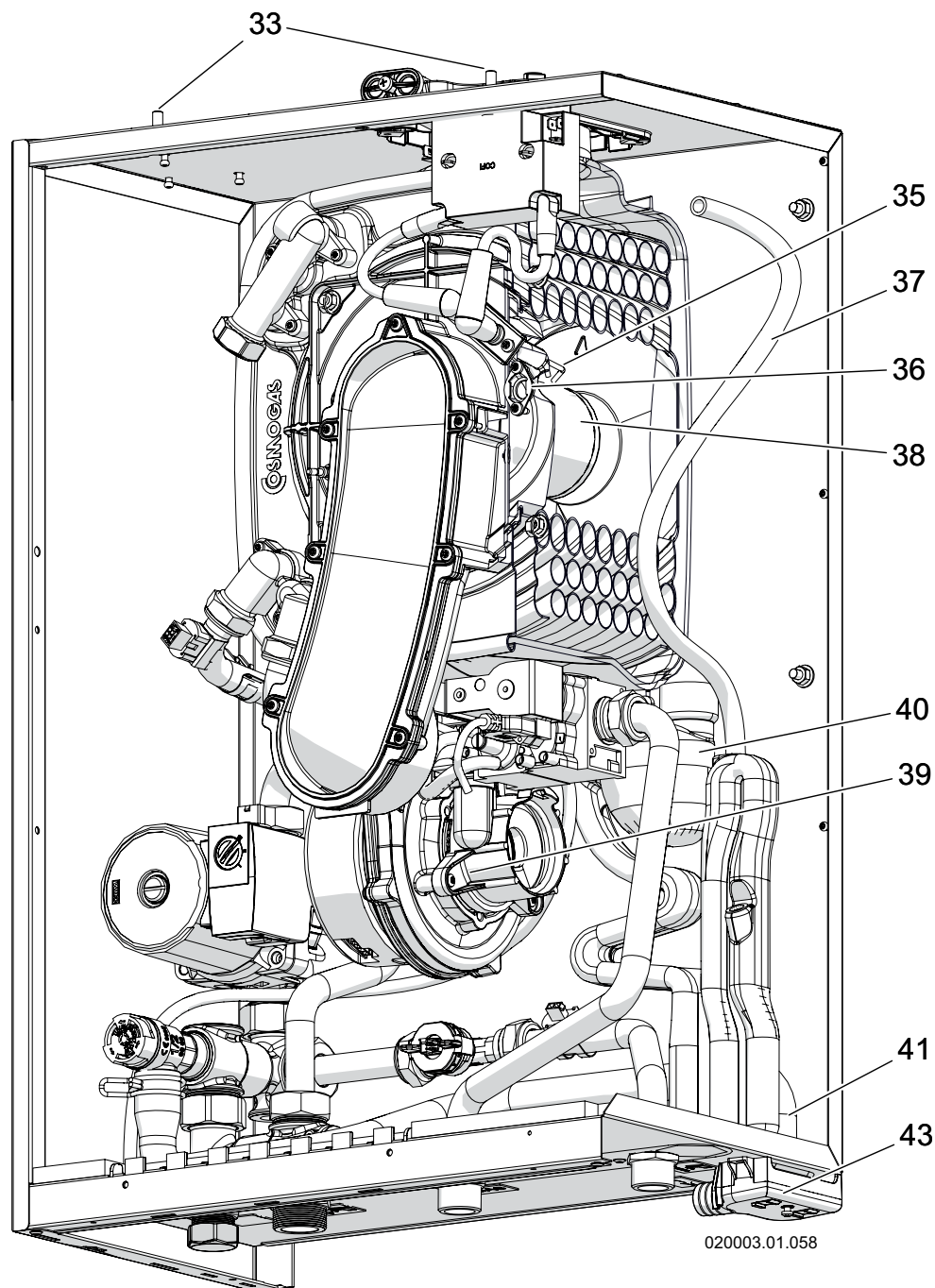
### 3 - MAIN COMPONENTS



- |  |   |
|--|---|
| 1 - Command and control board                      | 16 - Wall fixing brackets                       |
| 2 - Electric connections board                     | 17 - -----                                      |
| 3 - Electric control board box                     | 18 - -----                                      |
| 4 - Lower cover                                    | 19 - Combustion air and exhaust flue connection |
| 5 - -----  | 20 - Combustion analysis points                 |
| 6 - Water flow rate measuring device               | 21 - Exhaust flue temperature sensor ( 1006 )   |
| 7 - Cold water inlet temperature sensor ( 1007 )   | 22 - Spark generator                            |
| 8 - Fan  | 23 - Ignition cables                            |
| 9 - -----  | 24 - Combustion gases non-return valve.         |
| 10 - -----   | 25 - Air inlet manifold                         |
| 11 - Double D.H.W. output sensor ( 1001 and 1005 ) | 26 - Gas valve                                  |
| 12 - -----   | 27 - Front casing                               |
| 13 - -----   | 28 - Safety valve                               |
| 14 - Pump  | 29 - Display                                    |
| 15 - Detection electrode                           | 30 - Control board                              |
|  | 31 - Gas valve adjustment service access hatch  |

Figure 3-1 - Water heater internal components

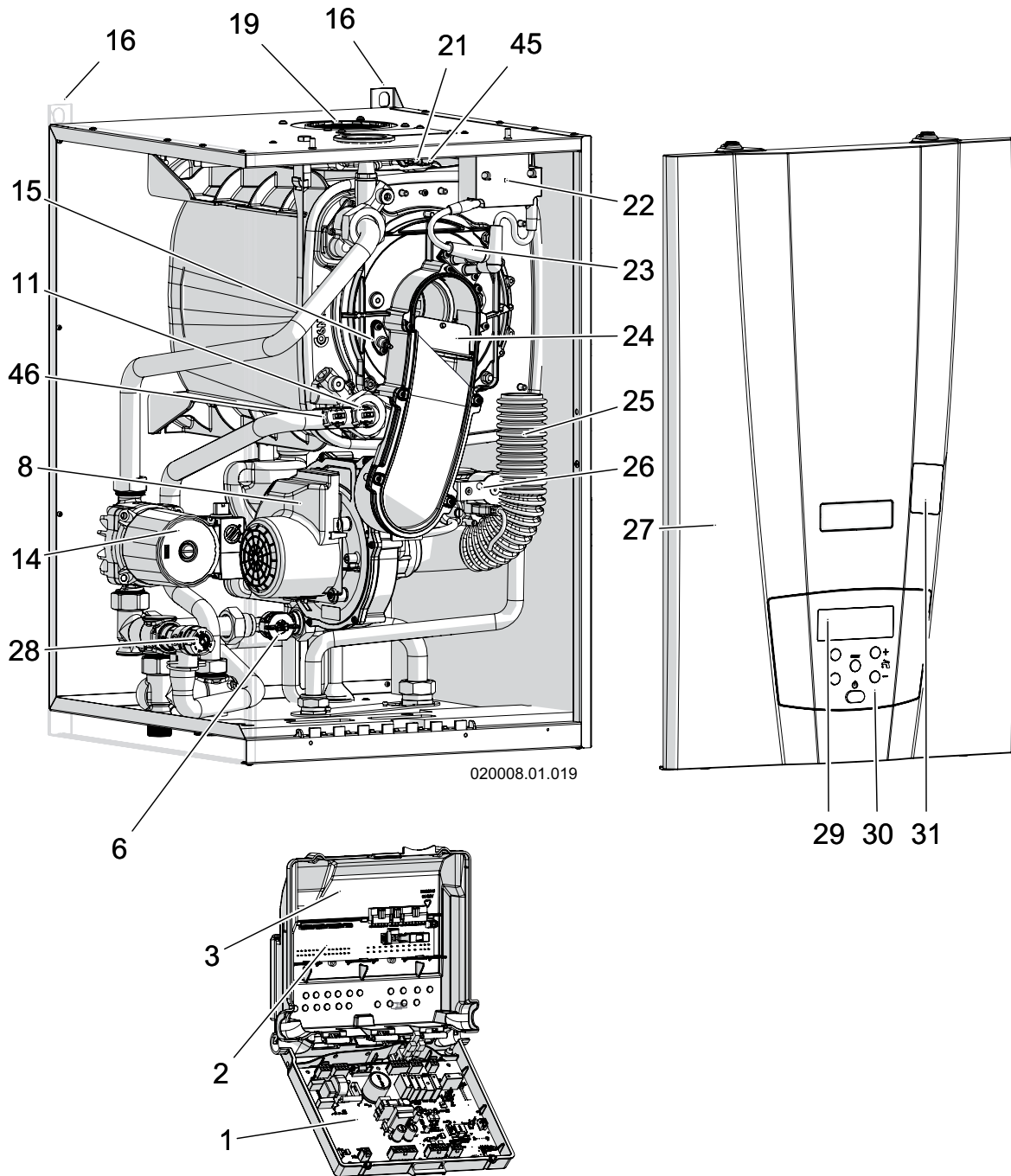
### 3 - MAIN COMPONENTS



- 32 - -----
- 33 - Front casing fixing tabs
- 34 - -----
- 35 - Ignition electrodes
- 36 - Gas burner viewing port
- 37 - Flue condensate collection collar drain pipe (connected to siphon)
- 38 - Burner
- 39 - Air/gas mixing unit
- 40 - Condensate drain siphon
- 41 - Safety valve drain pipe
- 42 - -----
- 43 - Condensate collection tank
- 44 - -----
- 45 - Flue gas temperature protection fuse
- 46 - Temperature sensor D.H.W. ( 100<sup>o</sup> )

Figure 3-2 - Water heater internal components

### 3 - MAIN COMPONENTS

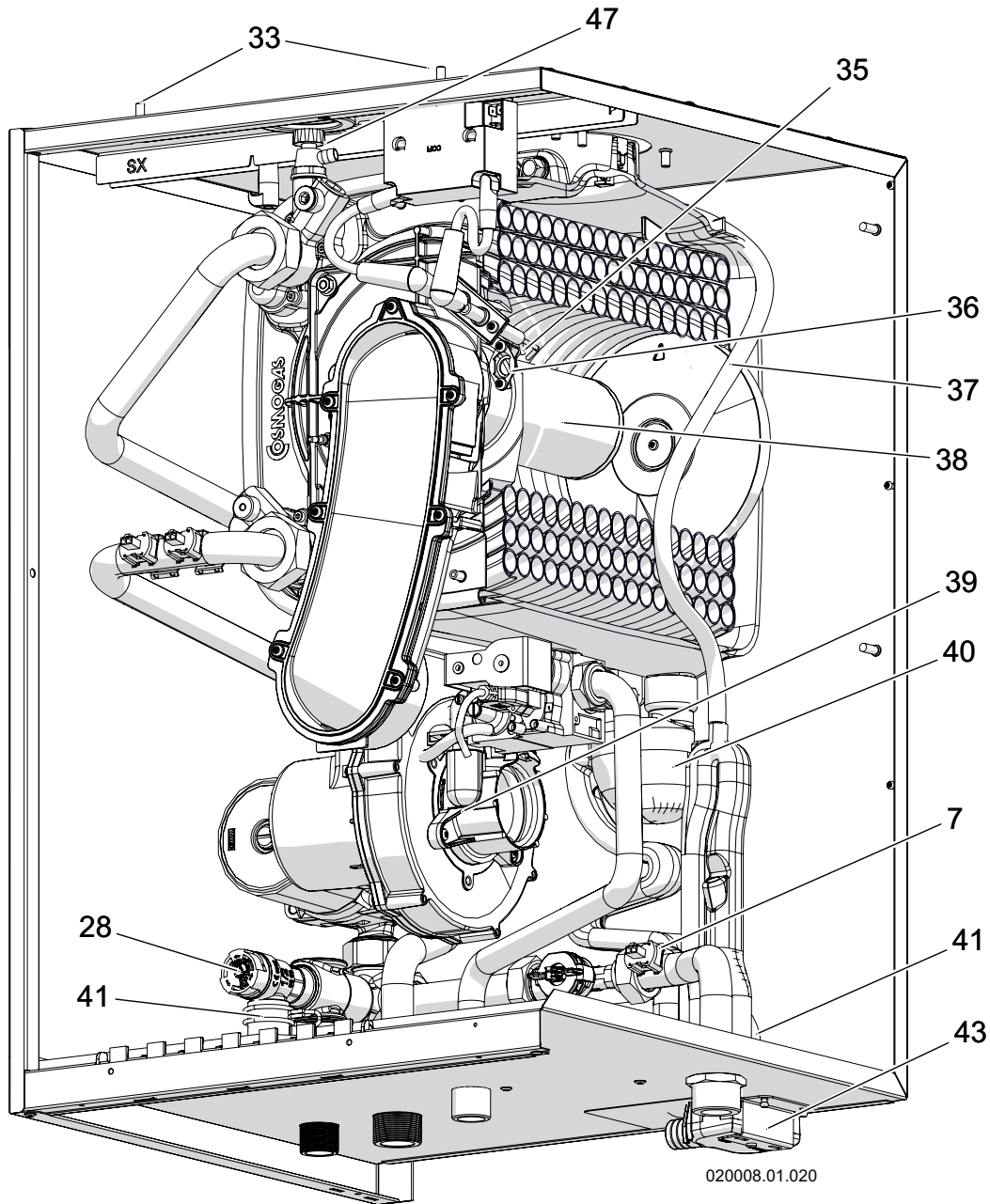


- |  |   |
|--|---|
| 1 - Command and control board                      | 16 - Wall fixing brackets                       |
| 2 - Electric connections board                     | 17 - -----                                      |
| 3 - Electric control board box                     | 18 - -----                                      |
| 4 - -----  | 19 - Combustion air and exhaust flue connection |
| 5 - -----  | 20 - -----                                      |
| 6 - Water flow rate measuring device               | 21 - Exhaust flue temperature sensor ( 1006 )   |
| 7 - Cold water inlet temperature sensor ( 1007 )   | 22 - Spark generator                            |
| 8 - Fan  | 23 - Ignition cables                            |
| 9 - -----  | 24 - Combustion gases non-return valve.         |
| 10 - -----   | 25 - Air inlet manifold                         |
| 11 - Double D.H.W. output sensor ( 1001 and 1005 ) | 26 - Gas valve                                  |
| 12 - -----   | 27 - Front casing                               |
| 13 - -----   | 28 - Safety valve                               |
| 14 - Pump  | 29 - Display                                    |
| 15 - Detection electrode                           | 30 - Control board                              |
|  | 31 - Gas valve adjustment service access hatch  |

Figure 3-3 - Water heater internal components



### 3 - MAIN COMPONENTS



- 32 - -----
- 33 - Front casing fixing tabs
- 34 - -----
- 35 - Ignition electrodes
- 36 - Gas burner viewing port
- 37 - Flue condensate collection collar drain pipe (connected to siphon)
- 38 - Burner
- 39 - Air/gas mixing unit
- 40 - Condensate drain siphon
- 41 - Safety valve drain pipe
- 42 - -----
- 43 - Condensate collection tank
- 44 - -----
- 45 - High limit flue gas temperature fuse
- 46 - D.H.W. temperature sensor ( 1002)
- 47 - Air purge valve

Figure 3-4 - Water heater internal components



## 4 - OPERATION

Key to figure 4-1:

- 1 = Water heater
- 2 = Combustion air intake
- 3 = Exhaust flue
- 4 = Exhaust flue temperature sensor (Par. 1006)
- 5 = High limit flue gas temperature fuse
- 6 = Sealed chamber
- 7 = Water collection tub
- 8 = Heat exchanger outlet temperature sensor 1 (Par. 1001)
- 9 = Heat exchanger outlet temperature sensor 2 (Par. 1005)
- 10 = Burner
- 11 = Heat exchanger
- 12 = Fan
- 13 = Cold water temperature sensor (Par. 1007)
- 14 = Condensate collection siphon
- 15 = Air/gas mixer
- 16 = Gas valve
- 17 = Safety valve
- 18 = -----
- 19 = Pump
- 20 = Non-return valve
- 21 = Water flow meter
- 22 = -----
- 23 = Cap
- 25 = Manual gas valve (optional)
- 26 = Gas inlet
- 27 = Cold water inlet
- 28 = Safety valve condensate drain funnel
- 29 = Hot water outlet
- 30 = Hot water sensor (Par. 1002)

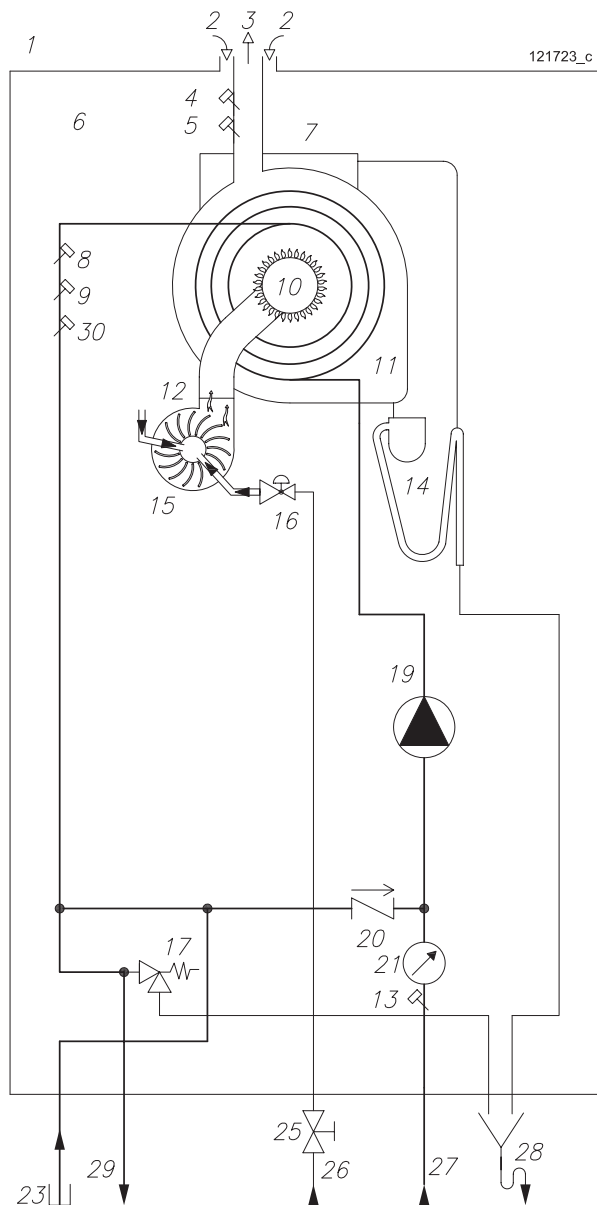


Figure 4-1 - Hydraulic layout

## 4 - OPERATION

### 4.1 - Operation and intended use of the appliance

This product is a condensing gas appliance, intended for the production of domestic hot water for use by people. Consider the D.H.W. circulation pump performance curves as illustrated in figure 4-2.

The temperature of the domestic hot water can be adjusted by following the relevant procedure in section 7.4.

☞ This appliance must be connected to a domestic hot water distribution system which has adequately sized pipes to convey the correct water volume and all pipes should be fitted with good quality insulation to optimise the performance of the water heater.

☞ Before installation of the domestic cold and hot water services should be flushed thoroughly in order to remove any residues or impurities which could compromise the good working order of the appliance.

☞ This appliance is not suitable for installation outdoors. It must not be exposed to temperature below zero or temperature above 50°C. Select a suitable sheltered location for the appliance.

☞ This appliance must be installed in a location which will not cause damage to objects or property in the event of water leaking from within the appliance or connections at the appliance.

☞ Check figure 5-1 concerning the minimum safety distances for installation and future maintenance.

Key to figure 4-2

A = Aguadens 16  
B = Aguadens 22  
C = Aguadens 37

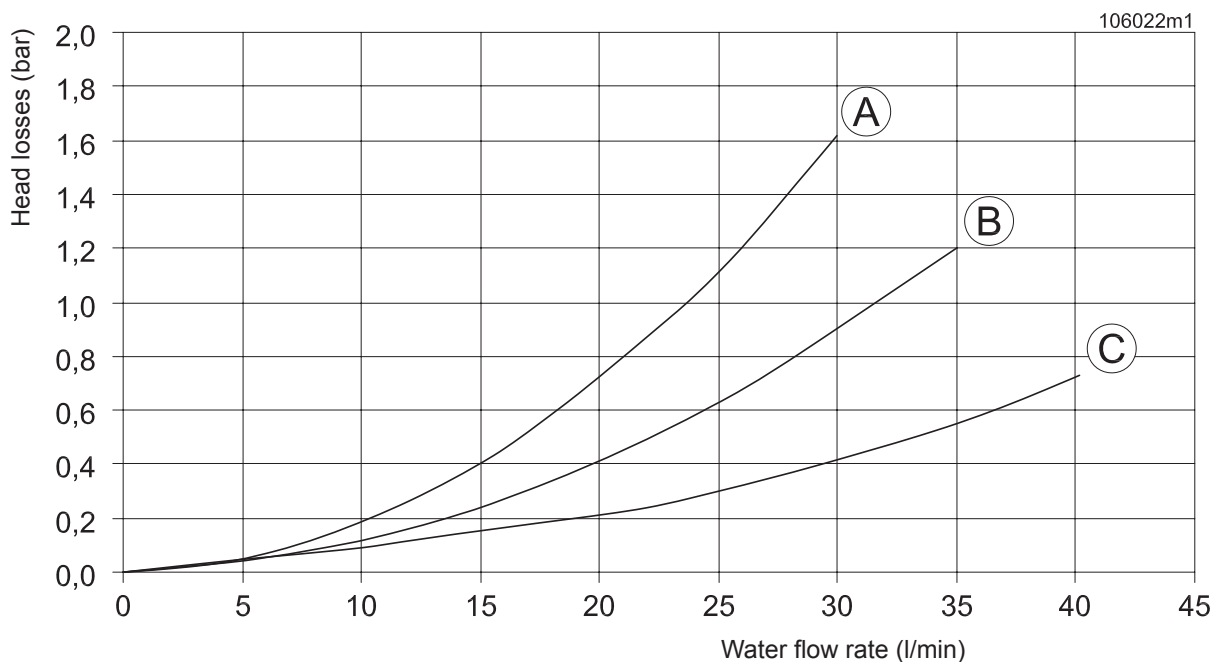
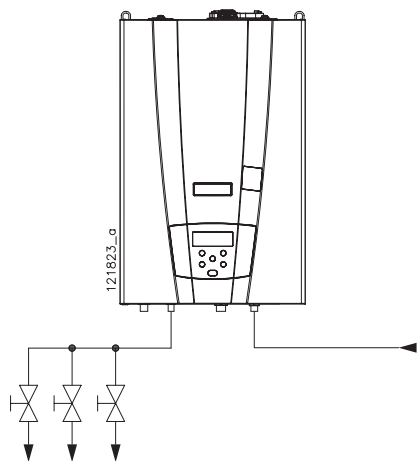


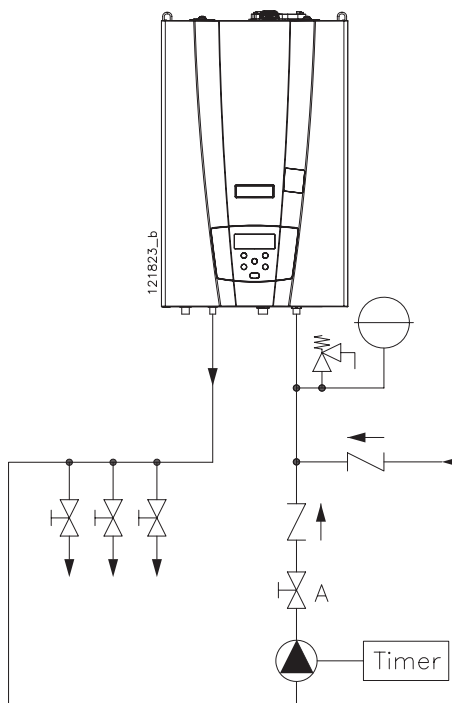
Figure 4-2 - Curve of the domestic water circuit losses

**4.2 - Examples of installation**

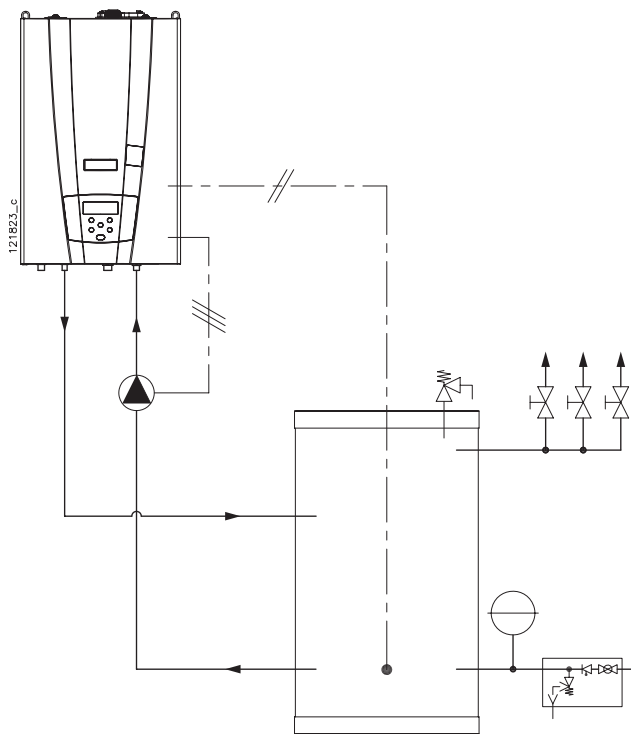
In figures 4-3, 4-4, 4-5, 4-6, 4-7 and 4-8 you can see some examples of correct installation while in figure 4-9 you can see one example of wrong installation.



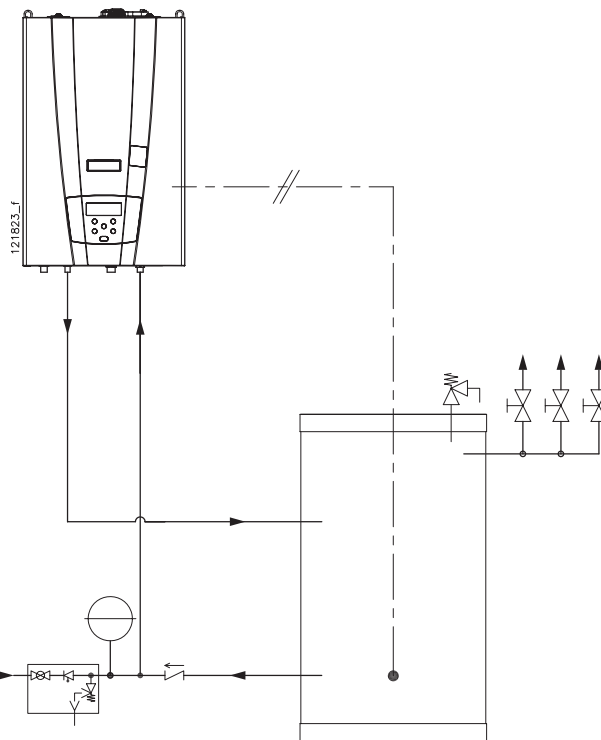
**Figure 4-3 - Example of basic installation**



**Figure 4-4 - Example of installation with secondary return performed by an external pump (see section 5.12)**



**Figure 4-5 - Example of installation with storage tank (see section 5.13)**



**Figure 4-6 - Example of installation with storage tank (see section 5.13)**

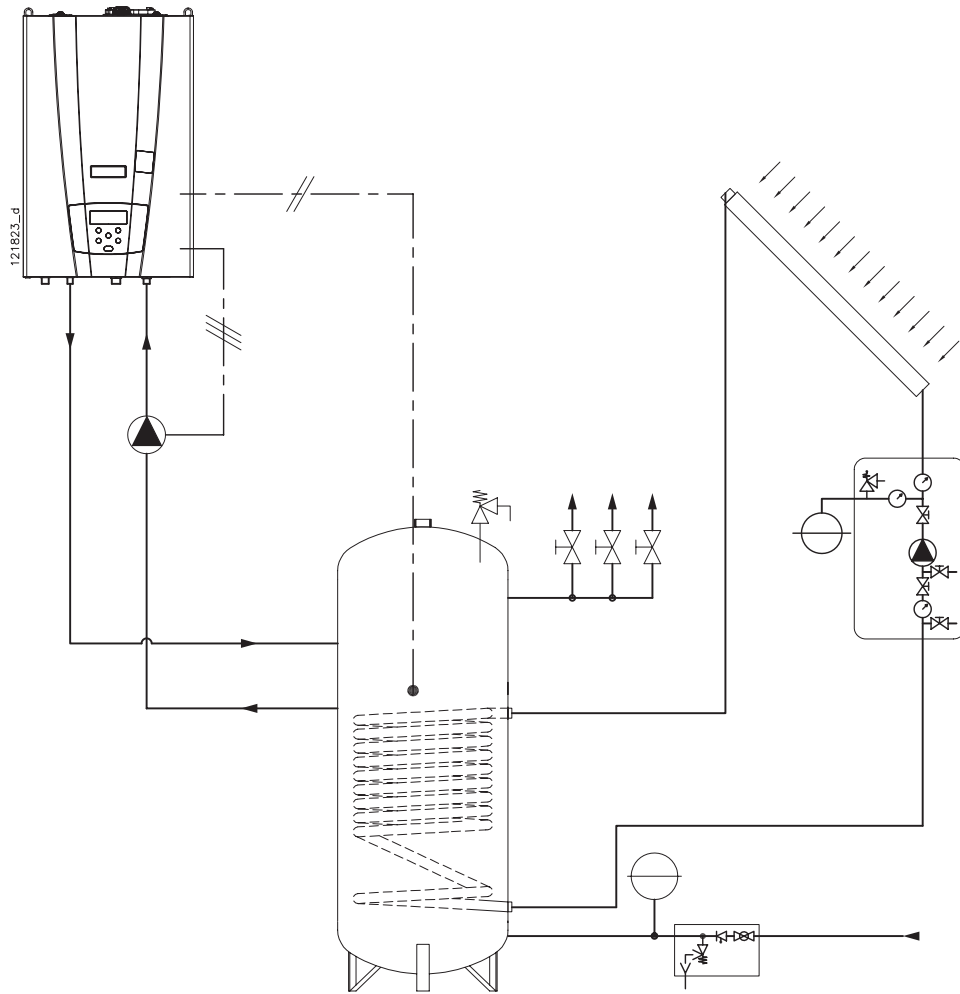


Figure 4-7 - Example of installation with solar panel and storage tank (see section 5.13)

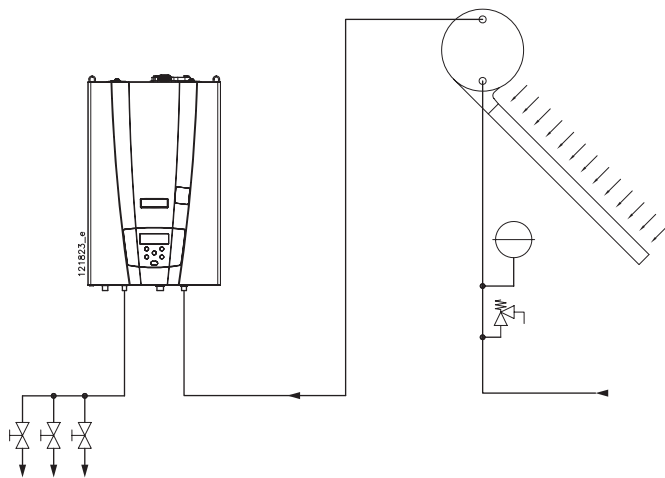


Figure 4-8 - Example of installation with solar panel (maximum inlet temperature to the water heater is 85°C).

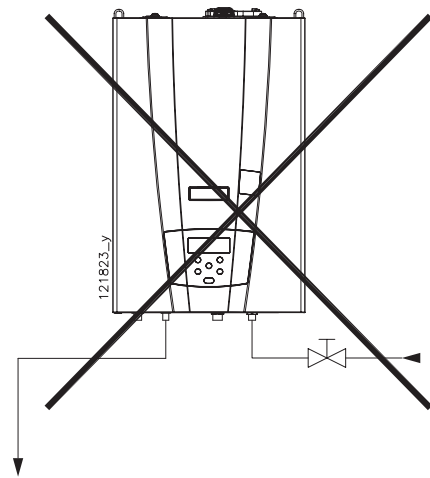


Figure 4-9 - Example of wrong installation

## 5 - INSTALLATION

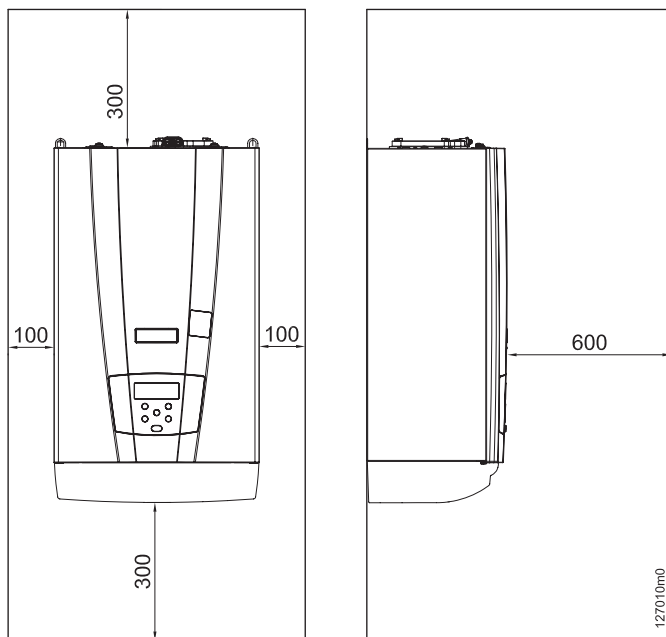


Figure 5-1 - Minimum safety distances

### 5.1 - Opening the packaging

The appliance is supplied in cardboard packaging. Open following the instructions given on the flaps of the packaging itself.

### 5.2 - Dimensions and minimum safety clearances

It is necessary to leave free spaces around the appliance as illustrated in figure 5-1 both for installation and maintenance.

### 5.3 - Choosing suitable installation location



**ATTENTION !!!** The appliance must be installed exclusively on a solid, vertical wall, which can support the weight.

The appliance must be installed in a suitable room taking into account the following factors:

- connection of the exhaust/air intake pipes;
- connection of the gas supply pipe;
- connection to the cold water supply;
- connection of the domestic hot water supply;
- electrical connection;
- connection of the siphon and safety valve to a suitable drain;

### 5.4 - Mounting the appliance

Refer to figure 5-4:

- 1.- place the paper template, provided with the appliance, against the wall;
- 2.- check that the template is square;
- 3.- mark the holes for the plugs and hydraulic fittings on the wall;
- 4.- remove the paper template;
- 5.- make the holes "A" and introduce the wall plugs "B";
- 6.- hang the appliance on the plugs "C"
- 7.- make the appliance hydraulic and gas connections;
- 8.- make the hydraulic fittings.

### 5.5 - Domestic hot and cold water



**CAUTION !!!** water quality must be within  $6,5 < \text{pH} < 8,5$  acidity value.



**CAUTION !!!** If water hardness exceeds  $20^\circ\text{f}$  ( $200 \text{ mg/l}$  or  $11,2^\circ\text{dH}$ ) a water softener must be installed on the incoming cold water supply.



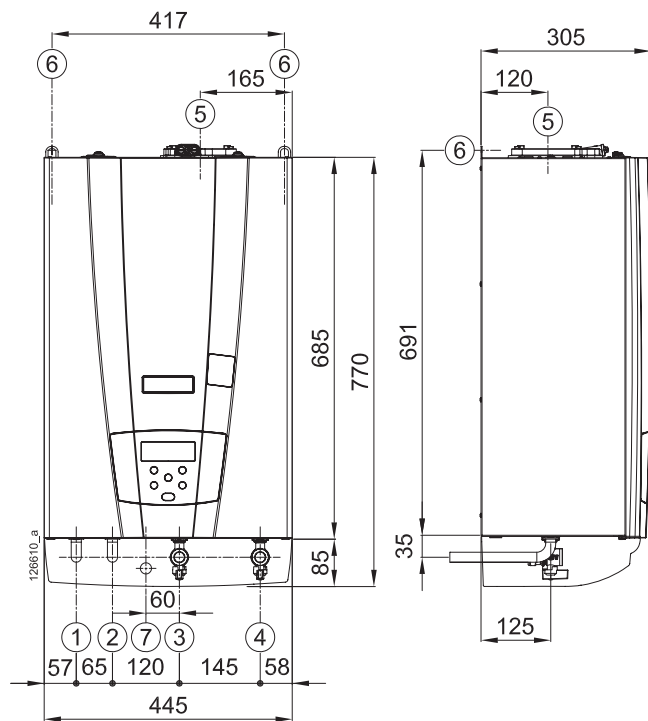
**CAUTION !!!** If water heater works at temperature higher than  $60^\circ\text{C}$  and until  $75^\circ\text{C}$ , water hardness must be lower than  $15^\circ\text{f}$  ( $150 \text{ mg/l}$  or  $8,4^\circ\text{dH}$ )



**CAUTION !!!** Water hardness must not be reduced lower than  $5^\circ\text{f}$  ( $50 \text{ mg/l}$  or  $2,8^\circ\text{dH}$ ). Softened water than  $5^\circ\text{f}$  ( $50 \text{ mg/l}$  or  $2,8^\circ\text{dH}$ ) is aggressive and can corrode the heat exchanger reducing life expectation.

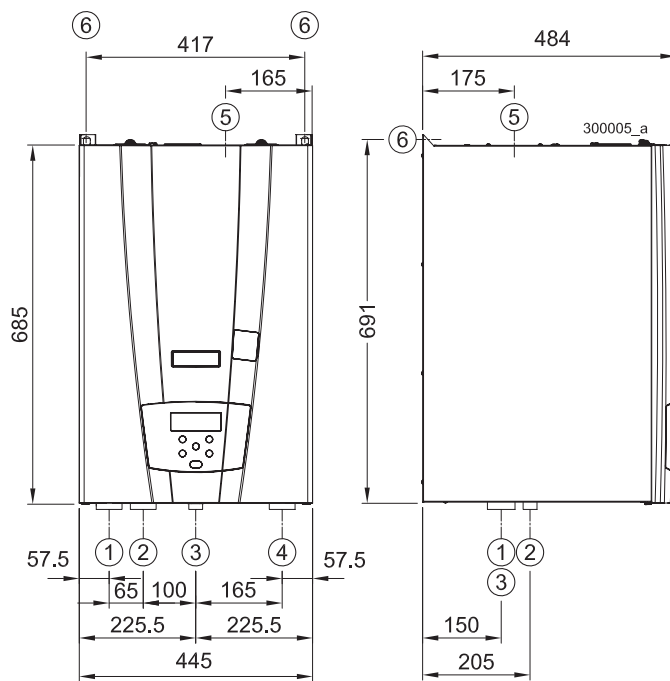


**CAUTION !!!** Install a filter with mesh no wider than  $0,5 \text{ mm}^2$  in the domestic cold water inlet.



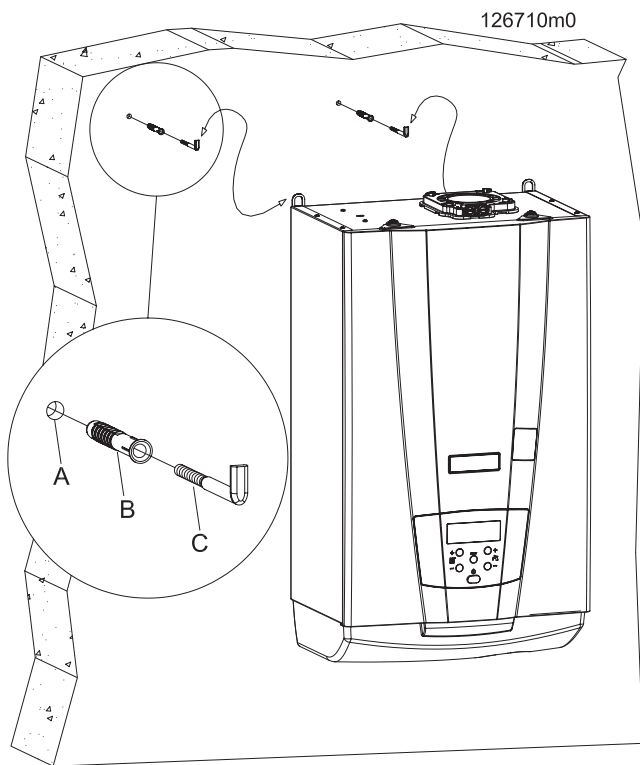
- 1 - 3/4" recirculation
- 2 - 1" D.H.W. outlet
- 3 - 3/4" gas inlet
- 4 - 3/4" cold water inlet
- 5 - Fumes exhaust/Air intake
- 6 - Support attachments
- 7 - Ø20 condensate drain

Figure 5-2 - Dimensions and attachments centre to centre distances AGUADENS 16 and 22



- 1 - 3/4" secondary return
- 2 - 1" D.H.W. outlet
- 3 - 3/4" gas inlet
- 4 - 1" cold water inlet
- 5 - Fumes exhaust/Air intake
- 6 - Support attachments

**Figure 5-3 - Dimensions and attachments centre to centre distances AGUADENS 37**



**Figure 5-4 - Appliance wall fixing detail**



**CAUTION !!!** This water heater can supply water at a temperature up to 95°C (setup of the safety high limit thermostat) and pressure of 10 bar (maximum setup of the relief valve). If the hot water system is built with materials not able to resist to this temperature and pressure, contractor must supply and install a device that will shut-off the appliance before the system material's maximum operating temperature and pressure are met.

In figures 5-2 and 5-3 the service and maintenance valves are not shown. Hydraulic and gas connections should be fitted with isolation valves to accommodate service and maintenance works.

## 5.6 - Gas



**ATTENTION !!!** It is prohibited to operate the appliance with the incorrect gas type. Check the data label on the appliance for Natural gas (G20) or Propane gas (G31) to ensure that the correct appliance is being installed.



**ATTENTION !!!** Check that the gas and supply pressure are those for which the appliance has been adjusted.

Two situations are possible:

- A - the gas and supply pressure correspond to the adjustment of the appliance. In this case, it can be connected;
- B - the gas and supply pressure do not correspond to the adjustment of the appliance. In this case, the appliance must be converted to the type of gas and supply pressure corresponding to those of the supply available.

The appliance is provided with the relevant gas conversion kit.

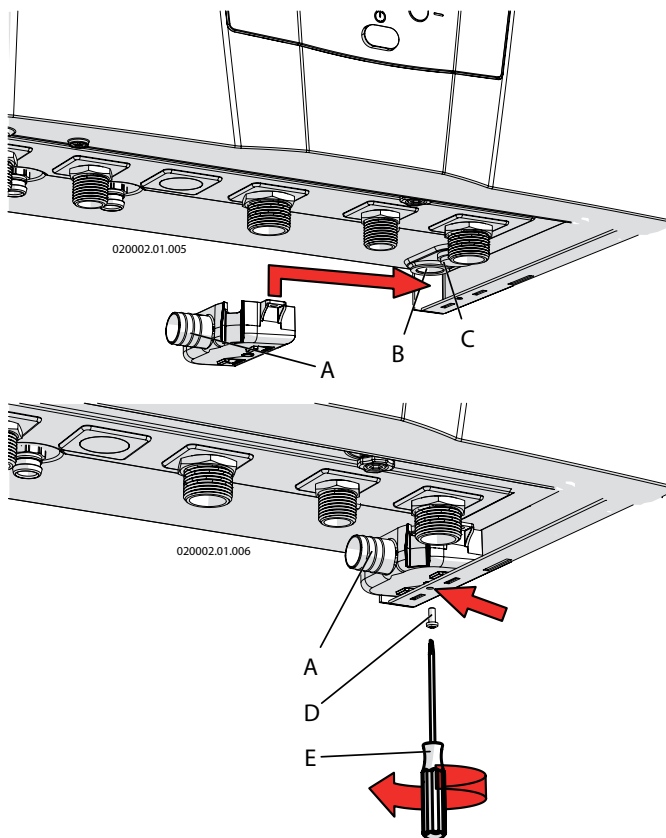
- ☞ Before the gas pipes are purged it is essential to ensure that the internal surfaces are clean and free of metal or plastic filings or any other solid pieces or liquids;
- ☞ An isolation valve must be installed on the gas supply pipe adjacent to the appliance;



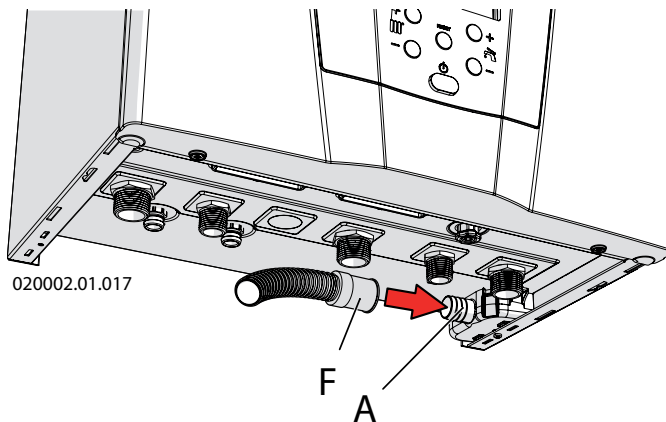
**ATTENTION !!!** Before supplying gas to the appliance, it is essential that the gas pipes have been pressure tested in accordance with the most recent applicable gas standards.

- ☞ to prevent damage to the appliance gas valve, the supply pressure should not exceed 50 mbar under any circumstances;
- ☞ if the gas pipe-work must be tested in excess of 50 mbar, ensure that the appliance is fully isolated.

Figures 5-2 and 5-3 shows the position and the diameter of the gas connection on the appliance. Ensure that the gas service pipe-work is adequately sized to provide the maximum volume flow rate at the required minimum pressure.



**Figure 5-5 - Safety valve drain and condensate drain connection**



**Figure 5-6 - Condensate drain pipe**

## 5.7 - Condensate drain

There is a siphon inside the appliance for the evacuation of condensate (see figures 3-2 and 3-4 detail "40") and to prevent combustion products from escaping, whose end corresponds to the pipe "B" in figure 5-5. This termination must be conveyed into an anti-odour siphon (figure 5-9 detail "G") to prevent bad odours returning into the environment (the anti-odour siphon "G" is supplied on request). The tank "A" is mounted in the factory as indicated in figure 5-5, the exhaust pipe "F" is mounted in the factory as indicated in figure 5-6. In particular, the condensate discharge must comply with the following:

- ☞ for room used for residential purposes and for office with more than 10 users, it can be connected to the domestic waste disposal plant by means of appropriate siphon with disjunction capable of preventing the pressurisation of the system (siphon prepared within appliance) and to prevent the return of bad odours from the sewer (detail "G" in figure 5-9). If the room used for office purposes has less than 10 users, before connection with the domestic waste drain, a condensate neutraliser is good practice (see section 9 for the value of acidity of the condensate and the quantities).
- ☞ be connected to a plastic (not copper) drain pipe with a minimum internal pipe diameter equal to or greater than 13 mm;
- ☞ be installed in a way to prevent the liquid from freezing; therefore pay attention to any external passings. It is prohibited to drain into gutters or drainpipes;
- ☞ to slope continuously towards the drain point, avoid high points, which could pressurise the pipe;

## 5.8 - Safety valve

The appliance is protected against overpressures by a safety valve calibrated to 10 bar (see figures 3-1 and 3-4 detail "28"). The safety valve drain (detail "C" in figure 5-5), along with the condensate drain (detail "B" in figure 5-5) must be conveyed to a pipe "F" (see figure 5-6) with minimum internal diameter of 13 mm. The pipe "F" must be then taken to the anti-odour siphon (detail "G" figure 5-9). This drain with siphon is used to prevent overpressures if the valve is opened and makes it possible for the user to check the eventual intervention. The pipe "F" in figure 5-6 is supplied by standard along with the tank "A" in figure 5-5. The anti-odour siphon "G" in figure 5-9 is provided on request.



**ATTENTION !!!** If not connected to the drain, whenever the safety valve should intervene, it could cause damage to persons, animals or objects.



## 5 - INSTALLATION

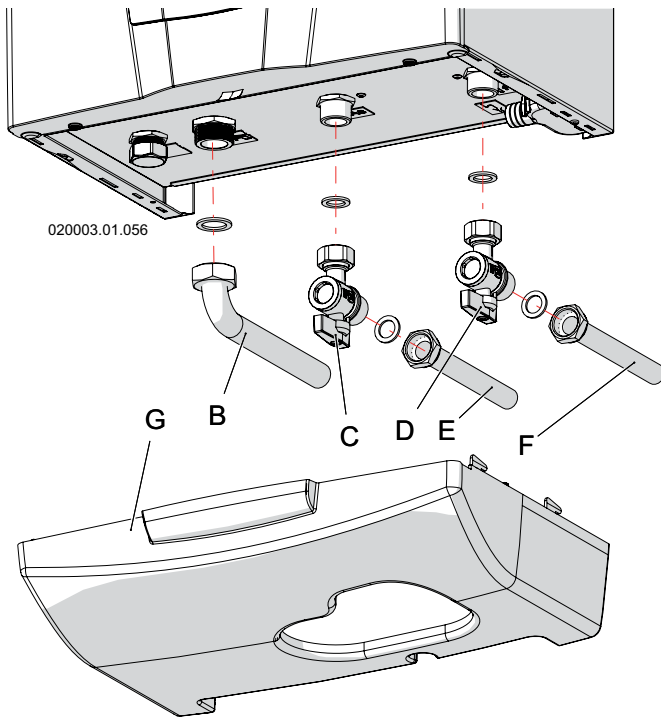


Figure 5-7 - Water and gas connections  
AGUADENS 16 and 22

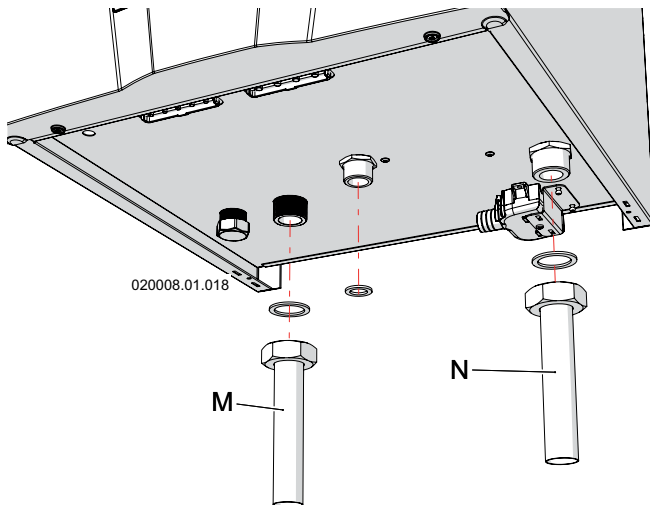


Figure 5-8 - Water and gas connections  
AGUADENS 37

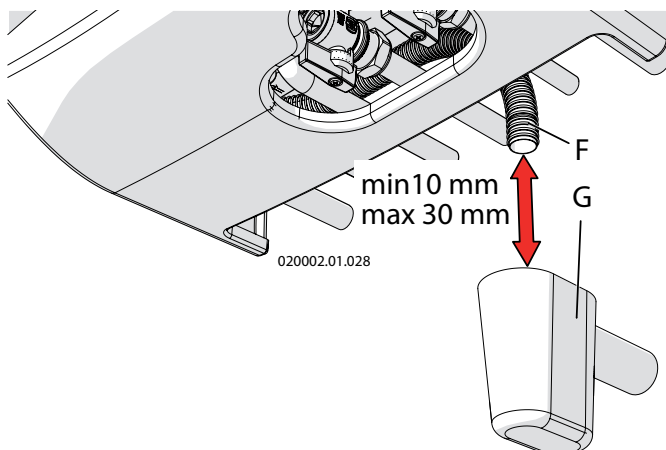


Figure 5-9 - F = condensing drain pipe  
G = siphon funnel (on request)

### 5.9 - Hydraulic and gas connections

The appliance models AGUADENS 16 and 22 is supplied as per standard with the fittings illustrated in figure 5-7, where:

- A = Ø 18 recirculation
- B = domestic hot water Ø 22
- C = 3/4" gas isolation valve (EN 331 type-approved)
- D = 3/4" domestic cold water isolation valve
- E = gas Ø 18
- F = domestic cold water Ø 18

Once the hydraulic and gas connections have been made, proceed with assembly of the lower cover "G" as indicated in figure 5-7.

The appliance models AGUADENS 37 is supplied as per standard with the fittings illustrated in figure 5-8, where:

- M = domestic hot water Ø 22
- N = domestic cold water Ø 22

### 5.10 - Water softener (on request)

If the appliance is installed in a geographical area where domestic water has hardness exceeding 20°F (200 mg/l), a polyphosphates softener must be installed on the cold water supply, in order to safeguard the appliance from any lime scale deposits.

Legenda di figura 5-10:

- 2 = Gas manual valve (EN 331 type-approved) (Field supplied)
- 3 = Water isolation valve / Flow rate selector (Field supplied)
- 4 = Water drain valve (Field supplied)
- 5 = Condensate drain (Field supplied)
- 6 = Gas inlet
- 7 = Cold water supply
- 8 = Domestic hot water
- 9 = Condensate drain pipe
- 10 = Water isolation valve (Field supplied)
- 11 = Filter (Field supplied)

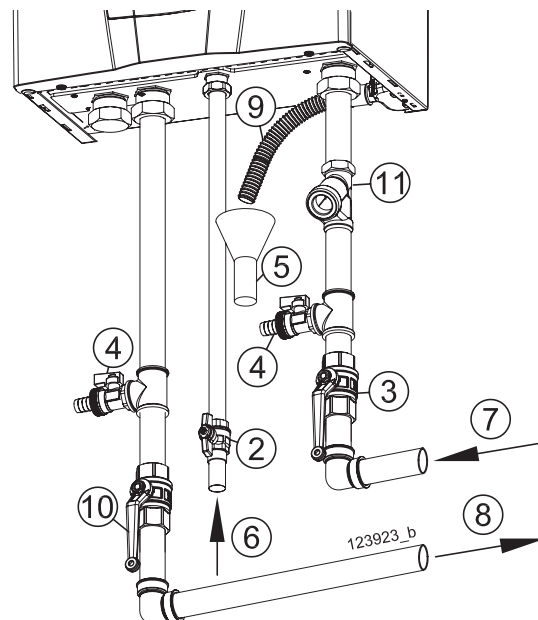


Figure 5-10 - Typical piping

## 5 - INSTALLATION

### 5.11 - Electrical connections



**ATTENTION !!! The appliance is only electrically safe when it has been correctly connected to an efficient earth circuit, performed as envisioned by the current Safety Standards.**

This fundamental safety requirement must be met. If in doubt, request a thorough control of the electric plant by a professionally qualified technician.

- ☞ Have a professionally qualified technician check that the electric plant is suitable for the electric power required by the appliance, indicated on the plate.
- ☞ The appliance must be connected to the mains electricity using a cable coupler. The use of adapters, multiple sockets, extensions, etc. is not allowed.
- ☞ The appliance must be connected to the mains electricity using a three-polar electric cable, with double isolation, minimum section of 1,5 mm<sup>2</sup> and resistant to a minimum temperature of 70°C (characteristic T).

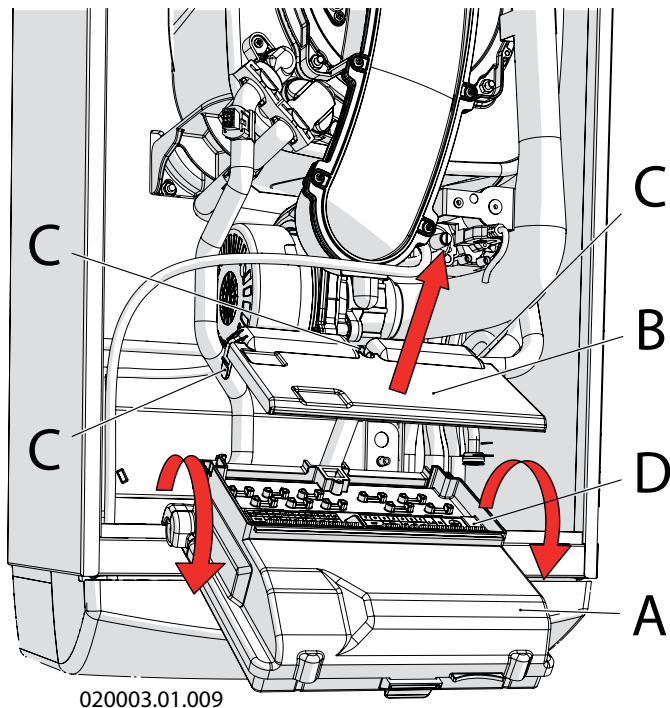
☞ For connection to mains electricity, a bi-polar switch must be envisioned in the vicinity of the appliance with a contacts opening distance of at least 3mm, as envisioned by the current regulations on the subject.

☞ Respect the polarity between the neutral phase during connection of the appliance.

☞ Make sure that the water plant pipes are not used as earth points for the electric or telephone plant. This piping is not suitable for this purpose, moreover, serious corrosion damage would occur in a very short time, on the appliance, piping and radiators.



**ATTENTION !!! the appliance is not protected against the effects caused by lightning.**



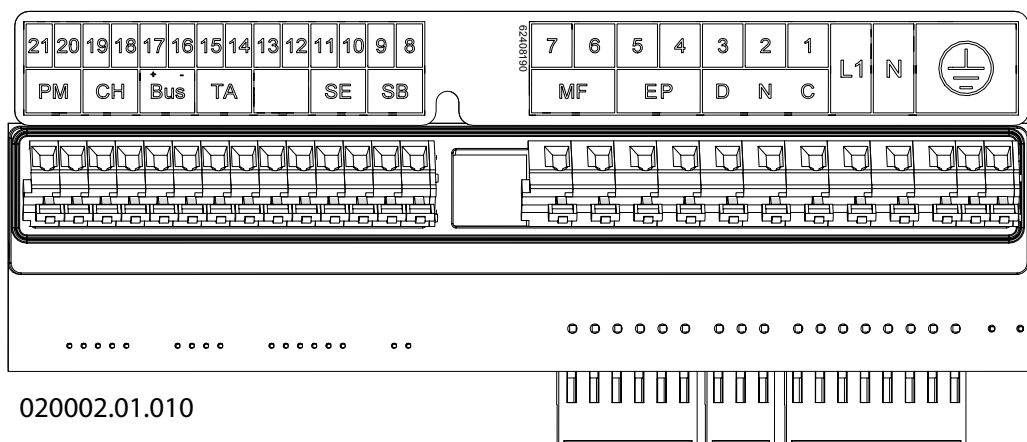
020003.01.009

#### Key for figure 5-11

- A = Commands board box;
- B = Electric connections board lid;
- C = Connections lid closing flaps;
- D = Electric connections board;

#### Key for electric contacts

- PM = Not used
- CH = Not used
- BUS = Not used
- TA = CR04 remote time control (if present)
- SE = Not used
- SB = Storage tank sensor (if present)
- MF = Multi-function output
- EP = Boiler pump (if present)
- DN = Not used
- (2 = Neutral; 3 = Line)
- L1 = Appliance power supply line
- N = Appliance power supply neutral
- EARTH SYMBOL = Earth contacts



020002.01.010

Figure 5-11 - Electric connections

## 5 - INSTALLATION

### 5.11.1 - Power supply cable connection

Proceed as follows to connect the power supply cable (refer to figure 5-11):

- 1.- use a three-polar cable with double isolation, with minimum section of 1,5 mm<sup>2</sup>
- 2.- remove the casing from the appliance following the relevant instructions in section 8.2;
- 3.- rotate the panel "A" towards the front of the appliance;
- 4.- operate on the flaps "C" and open the lid "B" as indicated by the arrow;
- 5.- lay the power supply cable through the fairlead in proximity of the contacts "L1", "N" and earth symbol;
- 6.- strip the cable, making sure to keep the earth cable (yellow green) 20 mm longer than the other two;
- 7.- connect the yellow-green cable to the earth terminals (see symbol)
- 8.- connect the brown cable (Phase) to the terminals L1
- 9.- connect the blue cable (Neutral) to the terminals N

### 5.11.2 - CR04 remote Time control (on request)

The CR04 remote time control is able to interact with the appliance.

Proceed as follow for the electric (refer to the figure 5-11):

- lay a bi-polar electric cable with minimum section of 1,5 mm<sup>2</sup>, from the appliance to the CR04 remote time control. The cable must also be shielded. Shield must be connected to the earth from the side of the appliance. The maximum length permitted is 100 metres;
- remove the casing and access to the junction box (see section 8.2);
- connect the cable to the terminals "14" and "15" of the appliance (see figure 5-11 "TA").
- connect the other side of the cable to the CR04 remote time control terminals (follow the CR04 instruction manual).



**ATTENTION !!!**

Since the cables of the remote control are subject to extremely low security voltage (24Vcc), they must pass through ducts different from the 230Vac supply cables.

Once the remote control has been connected, all the room temperature adjustments and domestic water temperature operations must be carried out directly on the same. Accordingly, remember to closely follow the instructions contained on the CR04 remote control.

---

## 5.12 - External secondary return configuration

if the appliance is envisioned with secondary recirculation (see figure 4-5), operate as follow:

- 1.- install the appliance as shown in figure 4-5;
- 2.- open one tap of the sanitary utilities to eliminate presence of air;
- 3.- turn off the secondary return pump;
- 4.- open one hot water sanitary tap and wait until the hot water temperature is stable;
- 5.- close the hot water sanitary tap;
- 6.- check that after 50 seconds after closing the tap, tap icon on the display has stopped flashing;
- 7.- if the tap icon keeps flashing, it means that the internal pump can run the water in the secondary return circuit to a value above 2 l/min (verifiable on the parameter 1062).
- 8.- operate on the valve "A" of Figure 4-4 in order to bring the recirculation flow rate to a value lower than 2 l/min;
- 9.- now the appliance can work correctly.

## 5 - INSTALLATION

### 5.13 - Connection water heater to Storage tank

If the storage tank is charged with internal pump (figure 4-7), must consider the residual head of figure 5-13 to size the system.

When the water heater is envisioned with storage tank, as shown in figure 4-7, before connect must be inserted into the appliance the by-pass valve "C" as shown in figure 5-12. Otherwise, if the storage tank is charged with external pump (see figure 4-6, 4-8 and 5-14), it is not necessary to insert the valve "C".

Proceed as follows for the electric connection (refer to the figure 5-11):

- 1.- disconnect the electric power supply from the appliance;
- 2.- disconnect the wire from the sensor detail "46" of figures 3-1 or 3-3;
- 3.- lay a bi-polar electric cable with minimum section of 1,5 mm<sup>2</sup>, which goes from the appliance to the storage tank temperature sensor and connect it to the appliance at terminals "8" and "9" (SB);
- 4.- connect the other end of the cable to the storage tank temperature sensor;
- 5.- introduce the temperature sensor inside the storage tank sample point (see figure 5-14 detail "8").
- 6.- connect the electric power of the storage tank pump to "EP" terminals of the water heater.
- 7.- set the parameters  $3012 = 1$  and  $3041 = 15$ .

the water temperature stored inside the storage tank can be chosen by the user in a range between 40 and 60°C.



**ATTENTION !!!** A domestic hot water temperature level exceeding 51°C can cause permanent injury/damage to persons, animals and objects. Children, the elderly and disabled must be protected against the potential risks of scalding, by introducing devices that limit the temperature of use of domestic hot water to utilities.

#### 5.13.1 - Anti- legionella precaution

If the appliance is connected to a storage tank for the preparation of domestic hot water, a disinfection cycle is envisioned against the legionella bacterium. This cycle envisions taking the storage tank to a temperature of 60°C (temperature at which the legionella bacteria dies) at least every week. It is for this reason that the water (at certain times) can reach the utilities at a higher temperature than set with the relative command.

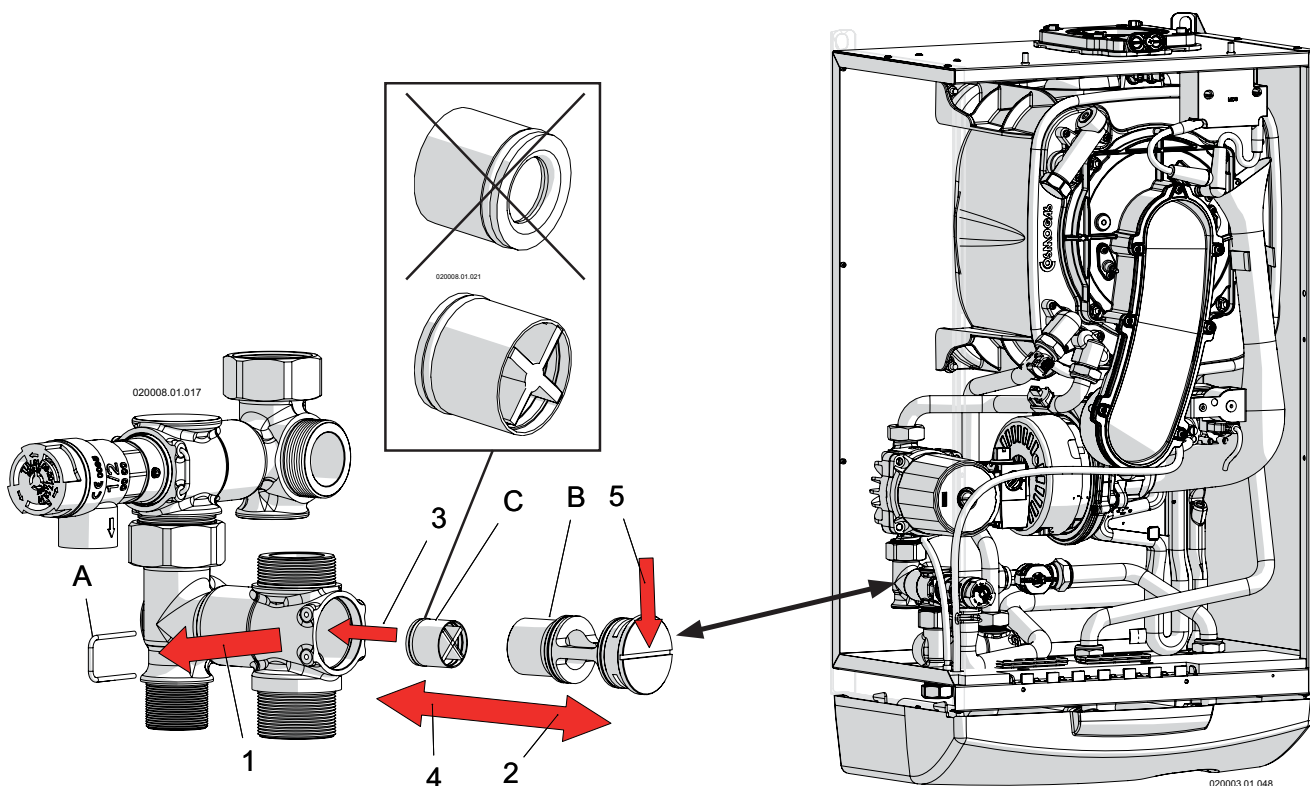
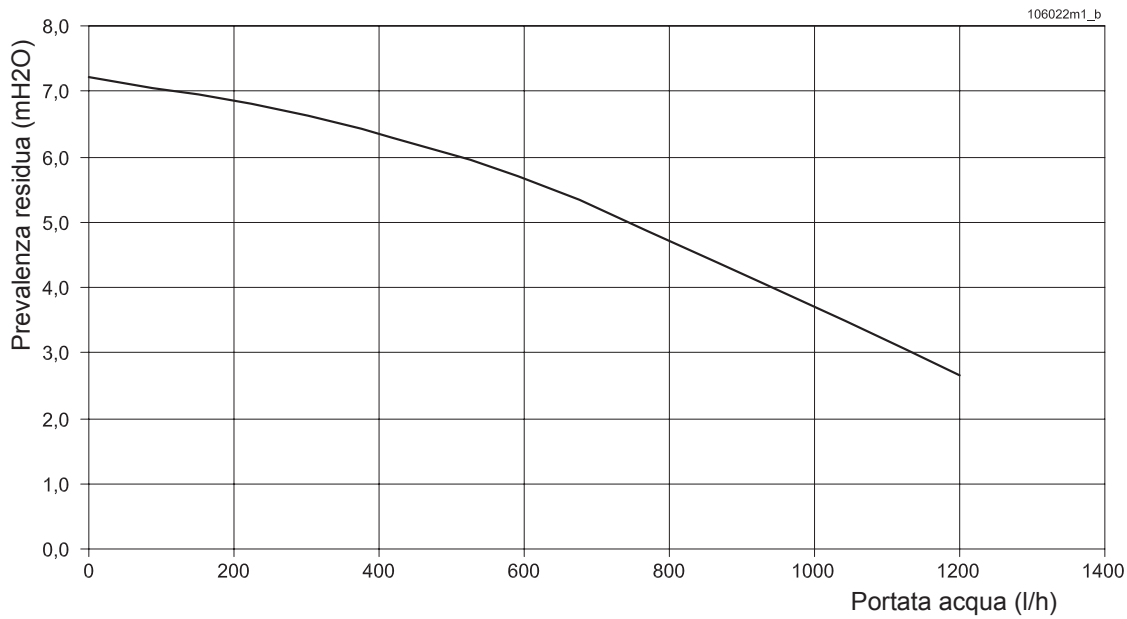
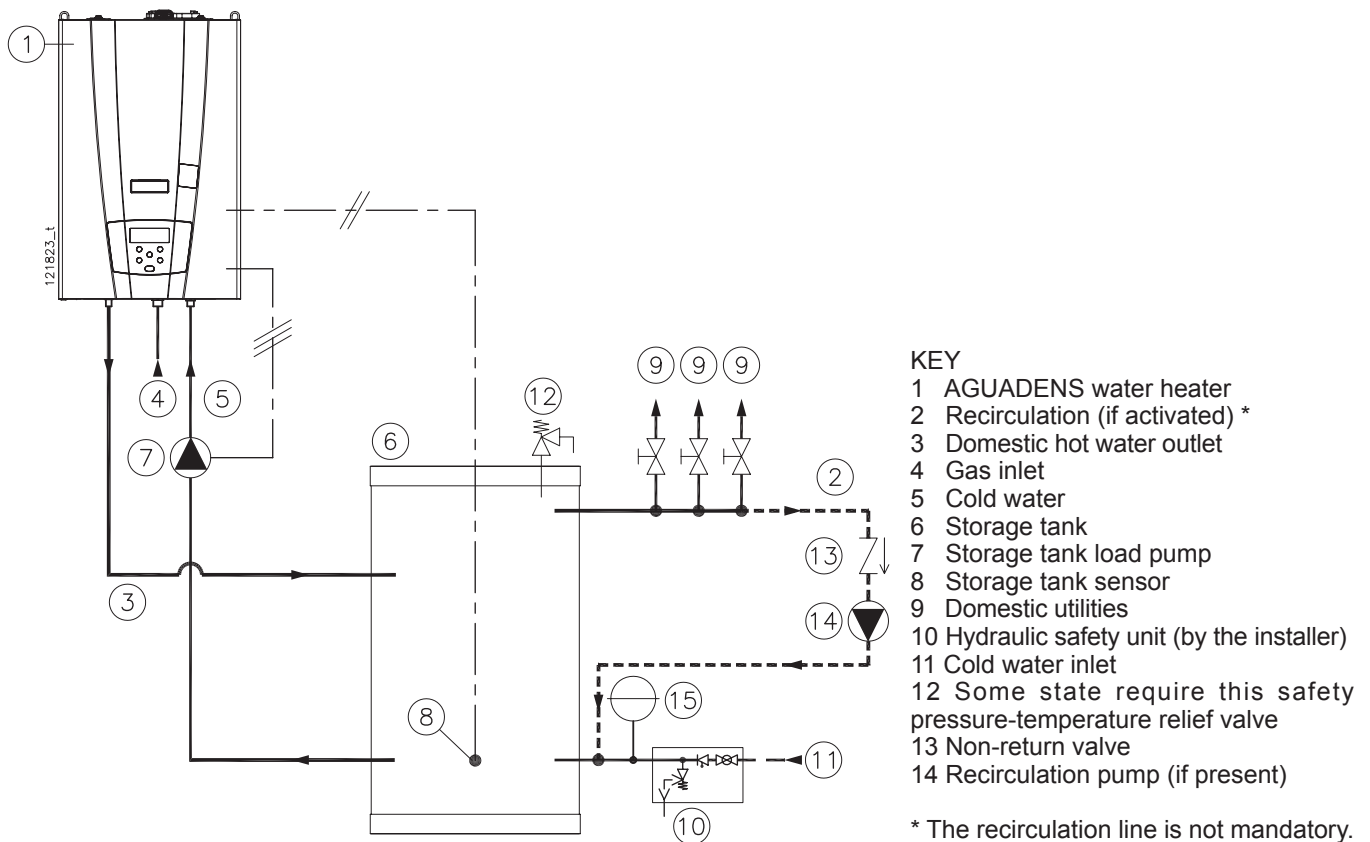


Figure 5-12 - bypass valve "C" to be included in case of installation with storage tank (respect the direction of the valve).



**Figure 5-13 - Curve of residual pressure for the storage tank charging with internal pump (see figure 4-7)**



**Figure 5-14 - hydraulic connection to storage tank**

## 5.14 - Flue systems



**ATTENTION !!!** The relevant national and local regulations must be strictly adhered to when installing the exhaust flue and combustion air pipes.



**ATTENTION !!!** The exhaust flue gases from the appliance can reach 90°C in certain conditions. Therefore, the plastic flue components must be capable of withstanding high temperatures and they must be approved for these specific appliance.



**ATTENTION !!!** This appliance is the “condensing” type. The polypropylene materials used in the manufacture of plastic exhaust flue system which are approved for use are designed to prevent corrosion which would otherwise be caused to the acidity of the condensate. AISI316 stainless steel exhaust flue system can also be designed for this purpose.

Regarding this, remember that the appliances of this type must have exhaust and intake pipes supplied by the manufacturer of the appliance itself. Other types of pipes, if used, must however be type-approved for this intended use. The types of exhaust for which the appliance is approved are given in the features table at the end of the manual under “type” and on the features plate affixed to the appliance, also under “type”. The symbols used to define exhaust is reported below:

- B23, separated with intake in room and exhaust through wall or roof.



**ATTENTION !!!** If the appliance is installed with the B23 type exhaust, it will take in air for combustion from the surrounding environment. Therefore, all precautions must be taken regarding ventilation of the rooms, which are prescribed by the national and/or local Standards.

- C13, coaxial in vertical wall

- C33, coaxial at the roof

- C43, separated with exhaust in flue, combined with intake in common channel.



**ATTENTION !!!** The appliances installed in type C43 must only be connected to conventional flues.

- C53, separated with exhaust on roof and intake on wall or however, in two potentially different pressure points.

- C63, the appliance can be fitted to type-approved exhaust and intake pipes of other brands.



**ATTENTION !!!** With the C63 type exhaust, the condensate coming from the chimney cannot be conveyed into the appliance.

- C83, separated with wall intake or another point independent from the intakes of other appliances and flue exhaust.

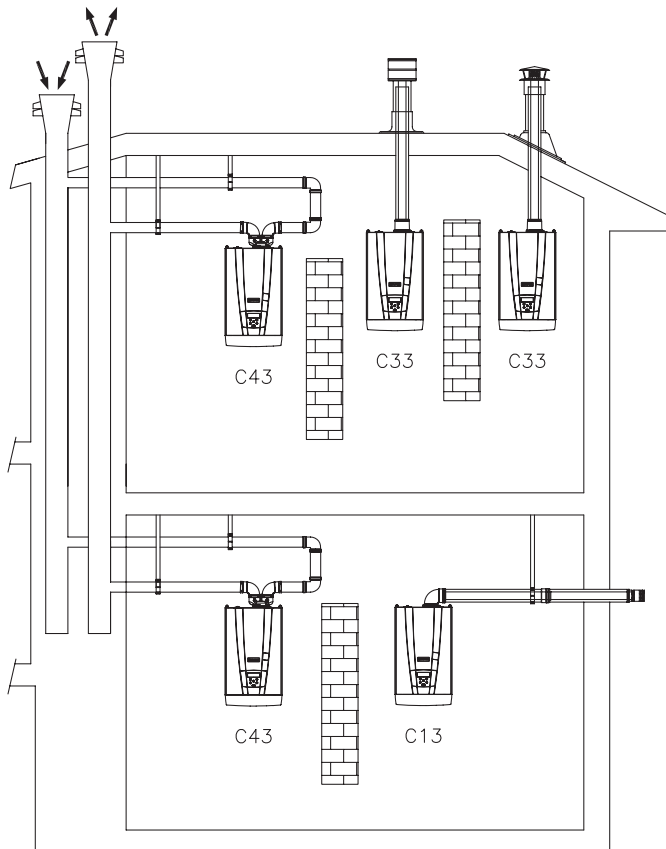
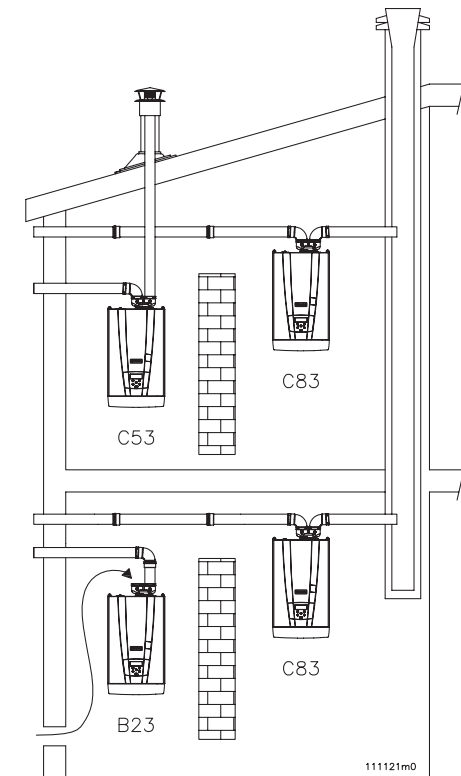


Figure 5-15 - Exhaust/intake systems



## 5 - INSTALLATION

During operation, especially in winter, a plume will be visible as the water vapour in the exhaust gases come into contact with the outside air. This plume should not cause any concern however the installer should discuss the matter with the customer prior to commencement of the installation in case the aesthetical impact of this plume might cause a problem.

### 5.14.1 - Exhaust flue with independent combustion air grille type B23

In the case of B23 type combustion agent air/fumes exhaust systems, it is indispensable that the rooms in which the appliances are installed have at least as much air as that required by combustion and ventilation of the room. It is therefore good practice to remember that the combustion of 1 m<sup>3</sup> of gas requires 11 cm<sup>3</sup> of air. The natural flow of air must take place directly through permanent openings made in the outside walls of the room to be ventilated; however away from sources of pollution, such as: vents of dubious origin, airborne industrial exhaust etc.

The ventilation openings must meet the following requirements:

- ☞ have sections with net passage of at least 6 cm<sup>2</sup> for every kW of heat input installed, with minimum of 100 cm<sup>2</sup>;
- ☞ be realised in a way that the opening inlets both inside and outside the wall cannot be blocked;
- ☞ be protected for example with grids, metal meshes, etc. The net section of the passage must not be reduced by these elements;
- ☞ be situated at a height more or less of the floor and such not to disturb the correct operation of the combustion products exhaust devices. Where this position is not possible, the section of the ventilation openings must be increased by at least 50%.

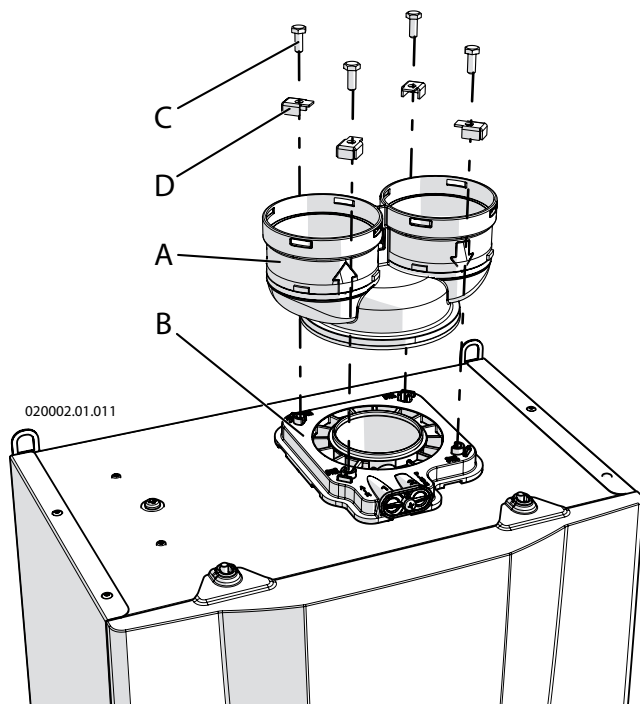
The flow of air can also be obtained from an adjacent room as long as:

- ☞ it has direct ventilation, in compliance with the previous points;
- ☞ only this gas appliance is installed in the room to be ventilated;
- ☞ the adjacent room is not a bedroom;
- ☞ the adjacent room is not a common part of the building;
- ☞ the adjacent room is not an environment with fire hazard, such as a hangars, garages, combustible materials warehouse, etc.;
- ☞ the adjacent room does not have a negative pressure with respect to the room to be ventilated due to reverse draught (which can be caused by the presence in the room of another appliance operating with any type of fuel, a fireplace and any other intake device for which an adequate air intake has not been envisioned);
- ☞ the flow of air from the adjacent room to that to be ventilated can take place freely through permanent openings with total net section not less than that indicated at the start of this section.

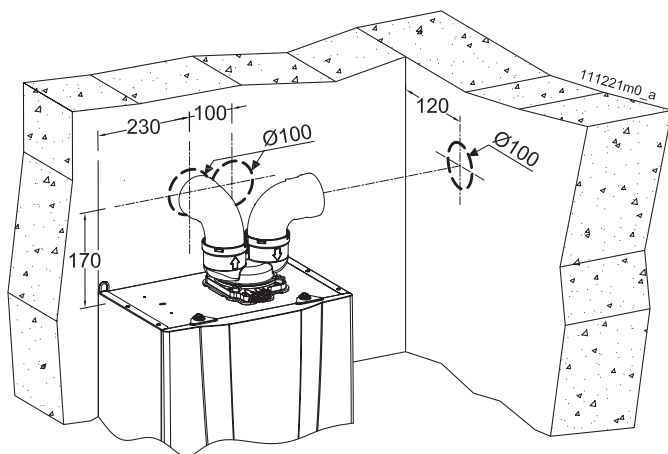
In rooms where gas appliances are installed, it may become necessary, as well as the input of combustion agent air, also to evacuate the stale air, with resulting release of an additional equal amount of clean air.

If the stale air is evacuated with the aid of a mechanical tool (electric fan) the following conditions must be respected:

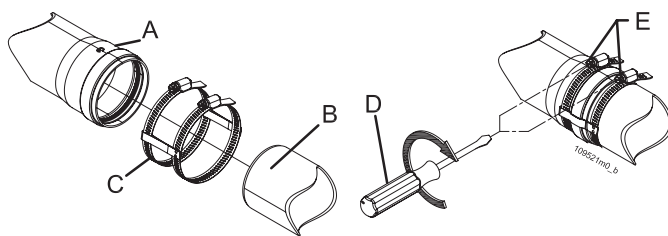
- a) If there is a common exhaust pipe in the room, it must be capped;
- b) The ventilation opening of the room in which the gas appliance is installed must be increased depending on the maximum air flow rate required at the electric fan.
- c) The action of the electric fan must not affect the correct evacuation of the combustion products. To this end, that stated above must be verified by draft testing, running the fan or extractor hood at its maximum power and the gas appliance at the maximum and minimum power.



**Figure 5-16 - Installation of the "80/80PP Split" System**



**Figure 5-17 - Clearance**



**Figure 5-18 - Fixing the exhaust and intake pipes**

## 5.14.2 - "Split 80/80PP" System (polypropylene) (Type C43; C53; C83) AGUADENS 16 and 22

The appliance is supplied as per standard without fittings for the connection of the fumes exhaust/air intake. To connect it to a "80/80PP Split" system, the relevant kit must be requested and must be installed as in figure 5-16. Fitting "A" can rotate freely by 360°, guaranteeing optimum installation versatility.

- ☞ On the exhaust flue side, it is mandatory to install polypropylene plastic pipes or AISI 316L stainless steel which are resistant to damage from condensation.
- ☞ Take particular care with the installation of pipes in the part that passes through the wall to the outside. The normal maintenance operations must always be possible, therefore install the pipes in a sheath so that they can slide out.
- ☞ The horizontal exhaust flue pipes must always have an inclination of 2% with the fall back towards the appliances as opposed to the wall terminal.
- ☞ The appliance is already set-up to collect the condensate, which must be fitted to a drain pipe (see section 5.7).



**ATTENTION !!! This condensate drain is designed to make all liquid produced flow from a single appliance. If several appliances are installed, each one must envision its own condensate drain.**

The fumes exhaust/air intake system can be extended up to a maximum distance as indicated in section 9. Every 90° bend has a loss equivalent to value on section 9. Every 45° bend has a loss equivalent to value on section 9.



**ATTENTION !!! The exhaust flue terminal must be appropriately protected against the effects of the wind (see also 7.9.1 error Loc 20).**



**ATTENTION !!! Mechanically secure the joints between the various component elements of the exhaust and intake pipe, through the use of fixing systems or equivalent systems. See figure 5-18.**



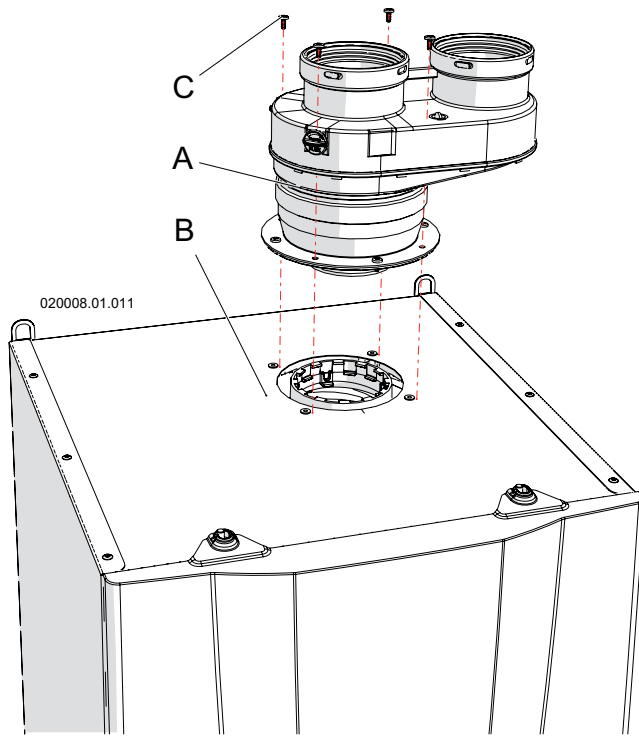
**ATTENTION !!! The temperature of the exhaust pipe can reach 90°C during operations. If it must pass through a wall that is sensitive to these temperatures, insert a protective heat-isolation sheath.**



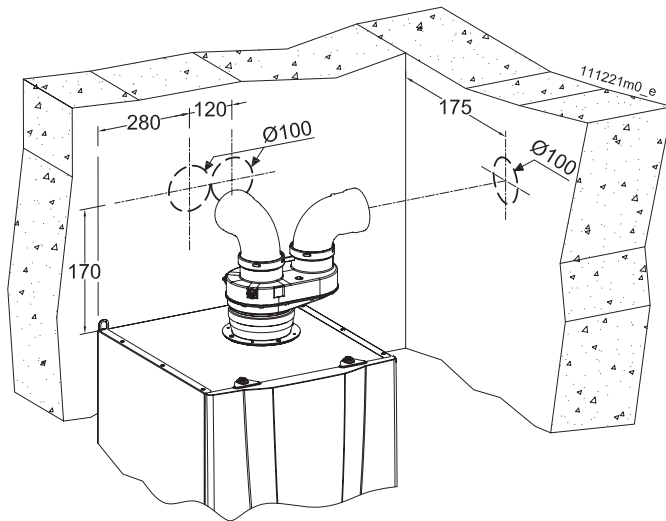
**ATTENTION !!! If the air intake and fumes exhaust terminals are positioned in the same wall, they must remain at a minimum distance of 1 metre.**



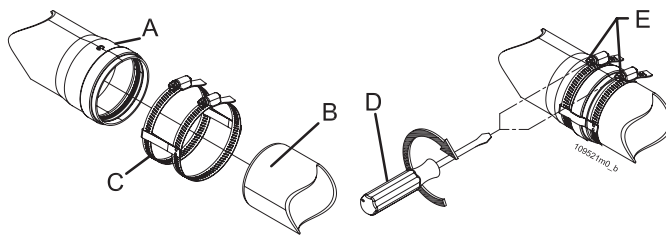
**ATTENTION !!! The exhaust and intake pipes must be appropriately sustained via rigid brackets positioned no more than 1 metre from each other. The brackets must be fixed to rigid walls that can support the weight of the pipe itself.**



**Figure 5-19 - Installation of the "80/80PP Split" System**



**Figure 5-20 - Clearance**



**Figure 5-21 - Fixing the exhaust and intake pipes**

### 5.14.3 - "Split 80/80PP" System (polypropylene) (Type C43; C53; C83) AGUADENS 37

The appliance is supplied as per standard without fittings for the connection of the fumes exhaust/air intake. To connect it to a "80/80PP Split" system, the relevant kit must be requested and must be installed as in figure 5-19. Fitting "A" can rotate freely by 360°, guaranteeing optimum installation versatility.

- ☞ On the exhaust flue side, it is mandatory to install polypropylene plastic pipes or AISI 316L stainless steel which are resistant to damage from condensation.
- ☞ Take particular care with the installation of pipes in the part that passes through the wall to the outside. The normal maintenance operations must always be possible, therefore install the pipes in a sheath so that they can be slid out.
- ☞ The horizontal exhaust flue pipes must always have an inclination of 2% with the fall back towards the appliance as opposed to the wall terminal.
- ☞ The appliance is already set-up to collect the condensate, which must be fitted to a drain pipe (see section 5.7).

**! ATTENTION !!! This condensate drain is designed to make all liquid produced flow from a single appliance. If several appliances are installed, each one must envision its own condensate drain.**

The fumes exhaust/air intake system can be extended up to a maximum distance as indicated in section 9. Every 90° bend has a loss equivalent to value on section 9. Every 45° bend has a loss equivalent to value on section 9.

**! ATTENTION !!! The exhaust flue terminal must be appropriately protected against the effects of the wind (see also 7.9.1 error Loc 20).**

**! ATTENTION !!! Mechanically secure the joints between the various component elements of the exhaust and intake pipe, through the use of fixing systems or equivalent systems. See figure 5-21.**

**! ATTENTION !!! The temperature of the exhaust pipe can reach 90°C during operations. If it must pass through a wall that is sensitive to these temperatures, insert a protective heat-isolation sheath.**

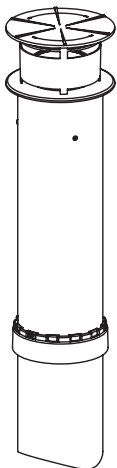
**! ATTENTION !!! If the air intake and fumes exhaust terminals are positioned in the same wall, they must remain at a minimum distance of 1 metre.**

**! ATTENTION !!! The exhaust and intake pipes must be appropriately sustained via rigid brackets positioned no more than 1 metre from each other. The brackets must be fixed to rigid walls that can support the weight of the pipe itself.**

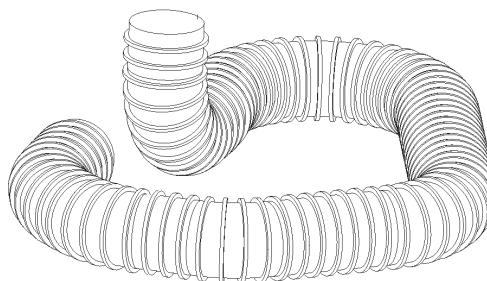
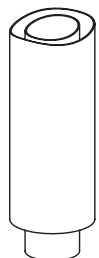
**5.14.4 - "Split 80/80PP" System (Type C43; C53; C83): accessories available**

To make the "80/80PP split" fumes exhaust/air intake system, we propose some of the most common accessories available; remember that a wide range can be consulted in the relevant catalogue: (the number after the code is used to recall the piece in the following drawings)

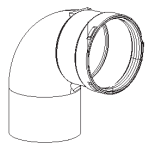
- 62617306 - N° 10 PP roof terminal
- 62617244 - N° 12 90° bend M/F PP
- 62617255 - N° 29 converts for pitched roofs from 15° up to 25°
- 62617236 - N° 11 extension M/F PP
- 62617249 - N°18 anti-slip bands for extensions PP
- 62617240 - N° 14 flexible hose M.F. PP L=20m
- 62617241 - N°16 spacer for flexible hose
- 62617238 - N° 17 telescopic joint PP
- 62617242 - N° 15 T-fitting PP
- 62617246 - N° 13 45° bend M/F PP



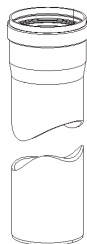
62617306



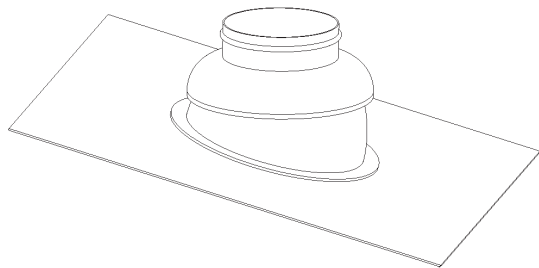
62617240



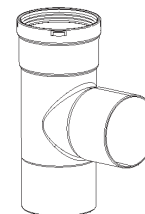
62617244



62617236



62617255

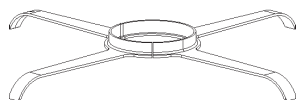


62617242

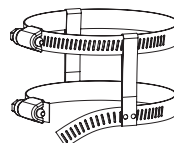
62617238



62617246



62617241



62617249

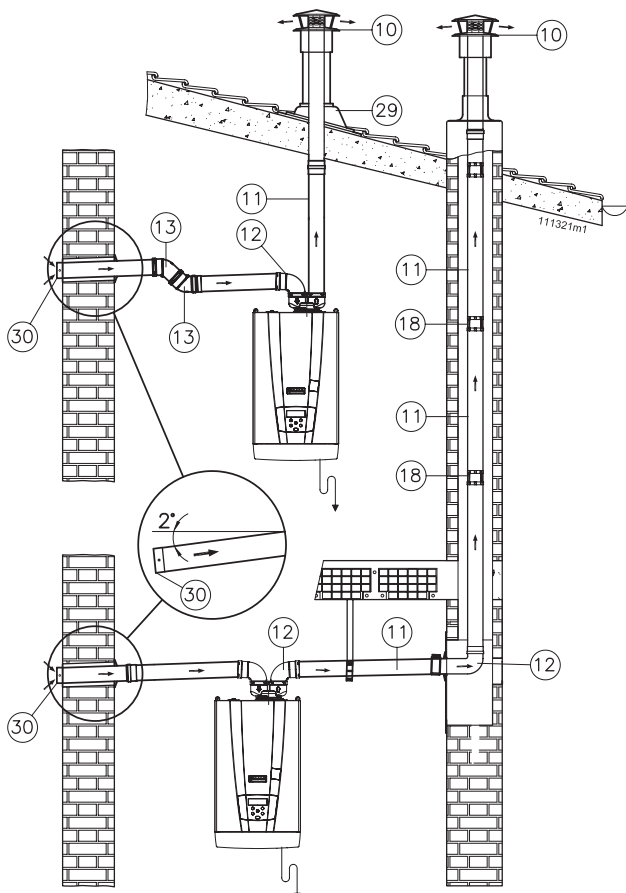


Figure 5-22 - Example of "80/80 PP System" installation

**5.14.5 - "Split 80/80PP" System (Type C43; C53; C83): installation examples**

In figure 5-22 two examples of installation are given:

- exhaust into chimney with collection of condensate inside the appliance itself.

The horizontal part of the fumes exhaust must slope towards the appliance.

The intake must slope towards the outside to prevent rain water entering.

- exhaust to the outside directly with the appliance pipes with condensate collection inside the appliance itself.

The intake must slope towards the outside to prevent rain water entering.

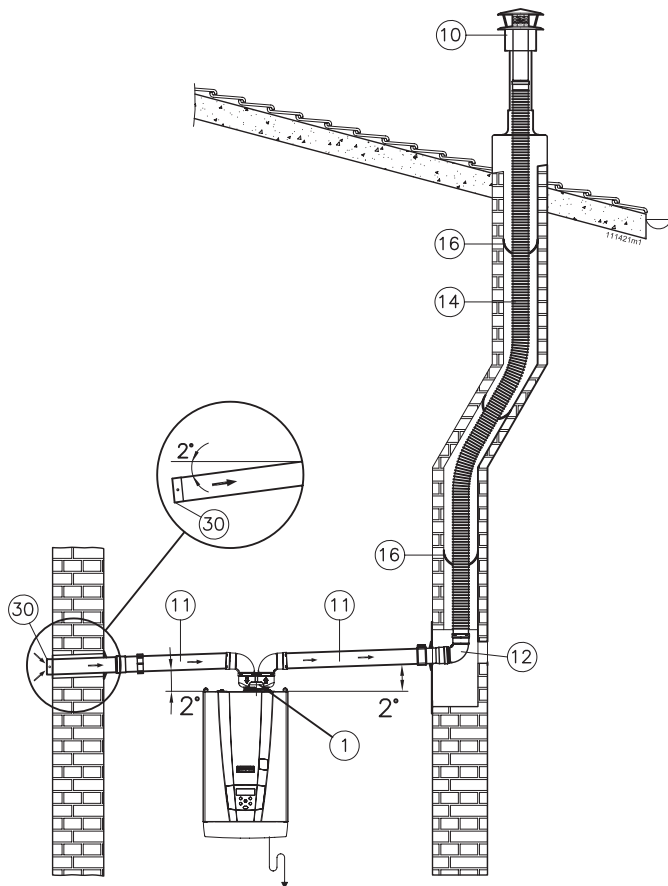


Figure 5-23 - Example of "80/80 PP System" installation

In figure 5-23 it is possible to see a separated type of fumes exhaust, where fumes exhaust was realised with flexible hose in polypropylene for piping of technical cells.

The condensate produced in the vertical pipe must all be conveyed into the appliance.

The intake must slope towards the outside to prevent rain water entering.

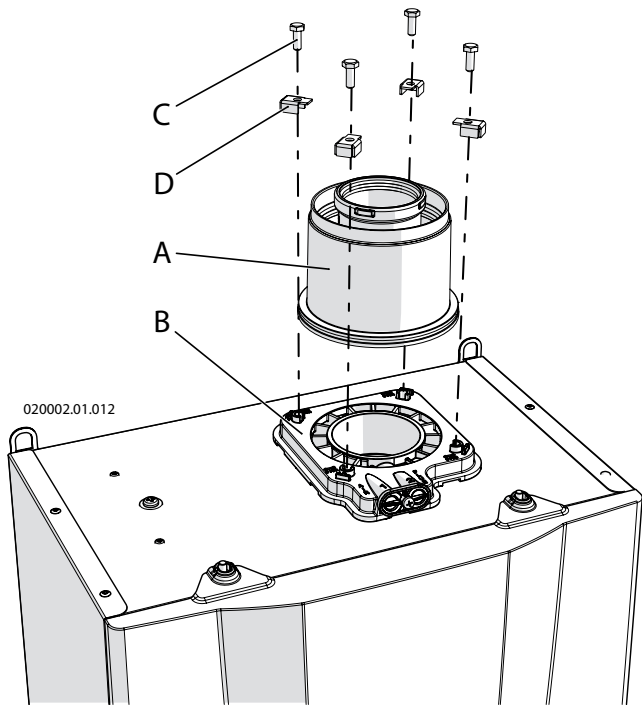


Figure 5-24 - Installation of vertical coaxial system

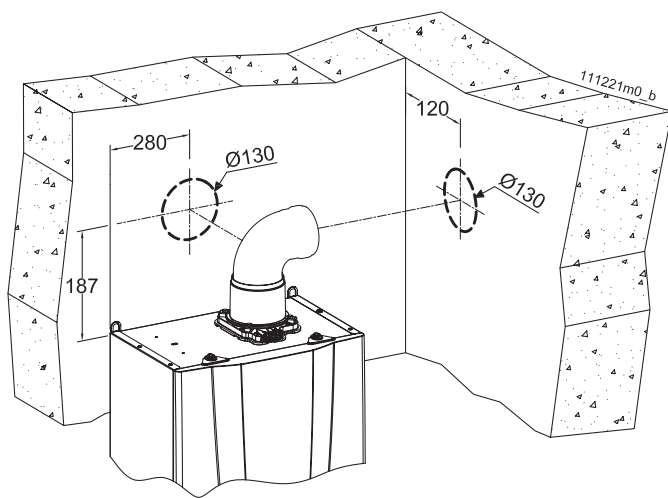


Figure 5-25 - Quotes and hole centre to centre distances for coaxial drain pre-installation

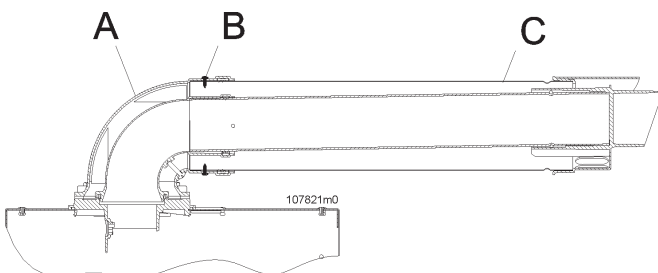


Figure 5-26 - Positioning the coaxial pipe

### 5.14.6 - “60/100PP vertical coaxial” System (polypropylene) (C13; C33 Type)

#### AGUADENS 16 and 22

The appliance is supplied as per standard without fittings for the connection of the fumes exhaust/air intake. To connect it to a vertical 60/100 system, the relevant kit must be requested and must be installed as in figure 5-24.

**ATTENTION !!!** Scrupulously follow the installation phases of the coaxial pipe as illustrated in figure 5-26. In particular:

- 1.- introduce the coaxial pipe “C” inside the bend “A”;
- 2.- fix the external pipe using the stainless steel self-threading screws “B”.

**ATTENTION !!!** The coaxial exhaust and intake pipes must be appropriately sustained via rigid brackets positioned no more than 1 metre from each other. The brackets must be fixed to rigid walls that can support the weight of the pipe itself.

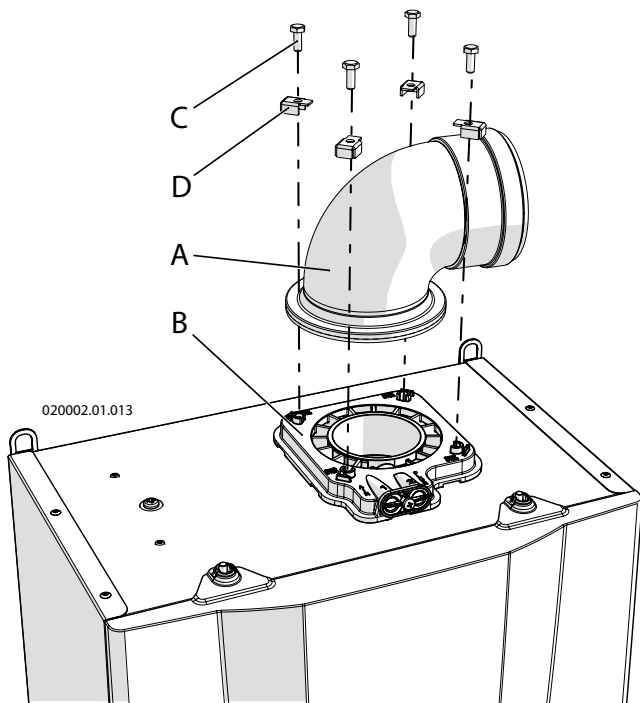
**ATTENTION !!!** Once these operations have been performed, check that the exhaust/intake terminal is exposed to the outdoors with the tolerances given in figure 5-30.

☞ Take particular care with the installation of pipes in the part that passes through the wall to the outside. The normal maintenance operations must always be possible, therefore install the pipes in a sheath so that they can slide out.

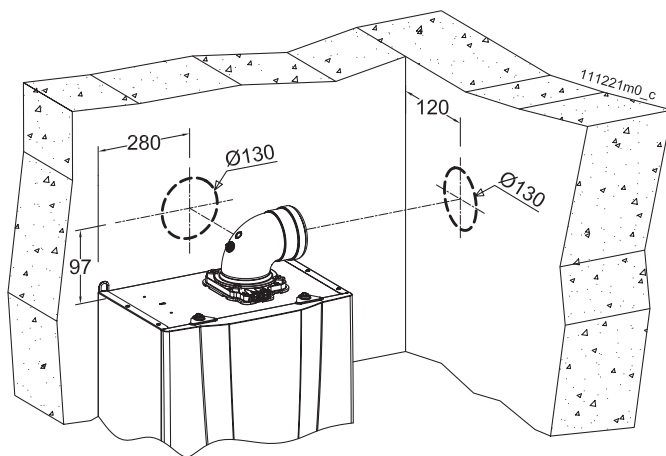
☞ The horizontal exhaust flue pipes must always have an inclination of 2% with the fall back towards the appliances as opposed to the wall terminal.

☞ The combined exhaust/air intake pipe can be extended up to a maximum distance as indicated in the table in section 9 at the end of the manual. Every 90° bend has a loss equivalent to value on section 9. Every 45° bend has a loss equivalent to value on section 9.

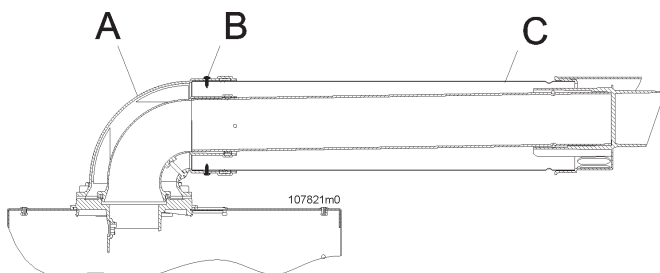




**Figure 5-27 - Installation of horizontal coaxial system**



**Figure 5-28 - Quotes and hole centre to centre distances for coaxial drain pre-installation**



**Figure 5-29 - Positioning the coaxial pipe**

## 5.14.7 - "60/100PP horizontal coaxial" System (polypropylene) (C13; C33 Type) AGUADENS 16 and 22

The appliance is supplied as per standard without fittings for the connection of the fumes exhaust/air intake. To connect the appliance to a 60/100 coaxial system, request the relevant kit and install it as in figure 5-27.

**⚠ ATTENTION !!!** Scrupulously follow the installation phases of the coaxial pipe as illustrated in figure 5-29. In particular:

1. - introduce the coaxial pipe "C" inside the bend "A";
2. - fix the external pipe using the stainless steel self-threading screws "B".

**⚠ ATTENTION !!!** The coaxial exhaust and intake pipes must be appropriately sustained via rigid brackets positioned no more than 1 metre from each other. The brackets must be fixed to rigid walls that can support the weight of the pipe itself.

**⚠ ATTENTION !!!** Once these operations have been performed, check that the exhaust/intake terminal is exposed to the outdoors with the tolerances given in figure 5-30.

☞ Take particular care with the installation of pipes in the part that passes through the wall to the outside. The normal maintenance operations must always be possible, therefore install the pipes in a sheath so that they can be slid out.

☞ The horizontal exhaust flue pipes must always have an inclination of 2% with the fall back towards the appliances as opposed to the wall terminal.

☞ The combined exhaust/air intake pipe can be extended up to a maximum distance as indicated in the table in section 9 at the end of the manual. Every 90° bend has a loss equivalent to value on section 9. Every 45° bend has a loss equivalent to value on section 9.



## 5.14.8 - "60/100PP Coaxial" System: accessories available

The following accessories are available on request to make the 60/100 coaxial fumes exhaust/air intake system:  
(the number after the code is used to recall the piece in the following drawings)

62617255 - N° 2 converts for pitched roofs from 5° to 25° extension L = 1000 mm

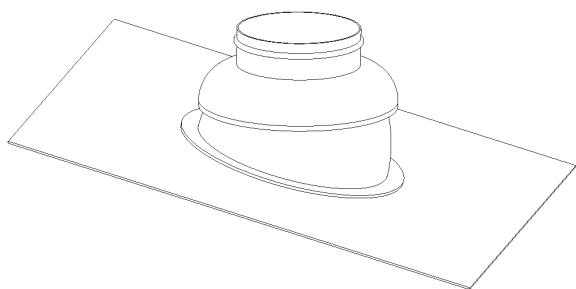
62617234 - N° 1 90° coaxial bend M/F PP

62617252 - N° 6 45° coaxial bend M/F PP

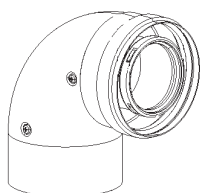
62617231 - N° 7 Coaxial extension L 1m PP

62617304 - N° 3 coaxial PP roof terminal

62617232 - N° 5 coaxial PP wall terminal



62617255



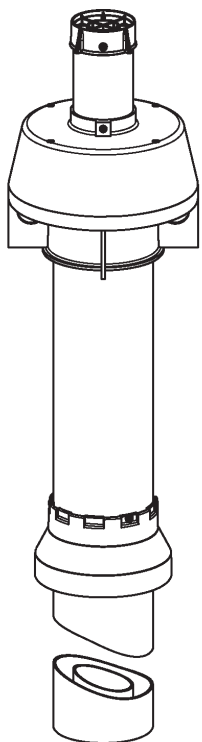
62617234



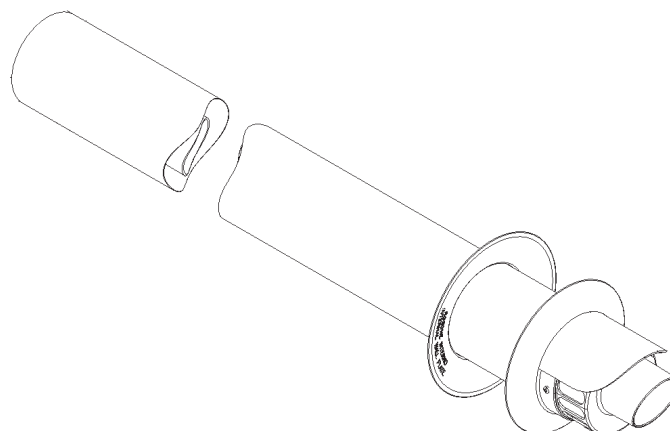
62617252



62617231



62617304



62617232

**5.14.9 - "60/100PP Coaxial" System: installation examples**

When a coaxial exhaust is made (see figure 5-30), both vertical and horizontal, the exhaust pipe slope upwards in a way to make the condensate flow into the appliance.



**ATTENTION !!!** The horizontal terminal must be protected against the accidental return of rain water. To do this, gables must be installed (or projections or balconies or relevant protections ) with the minimum dimensions given in figure 5-30

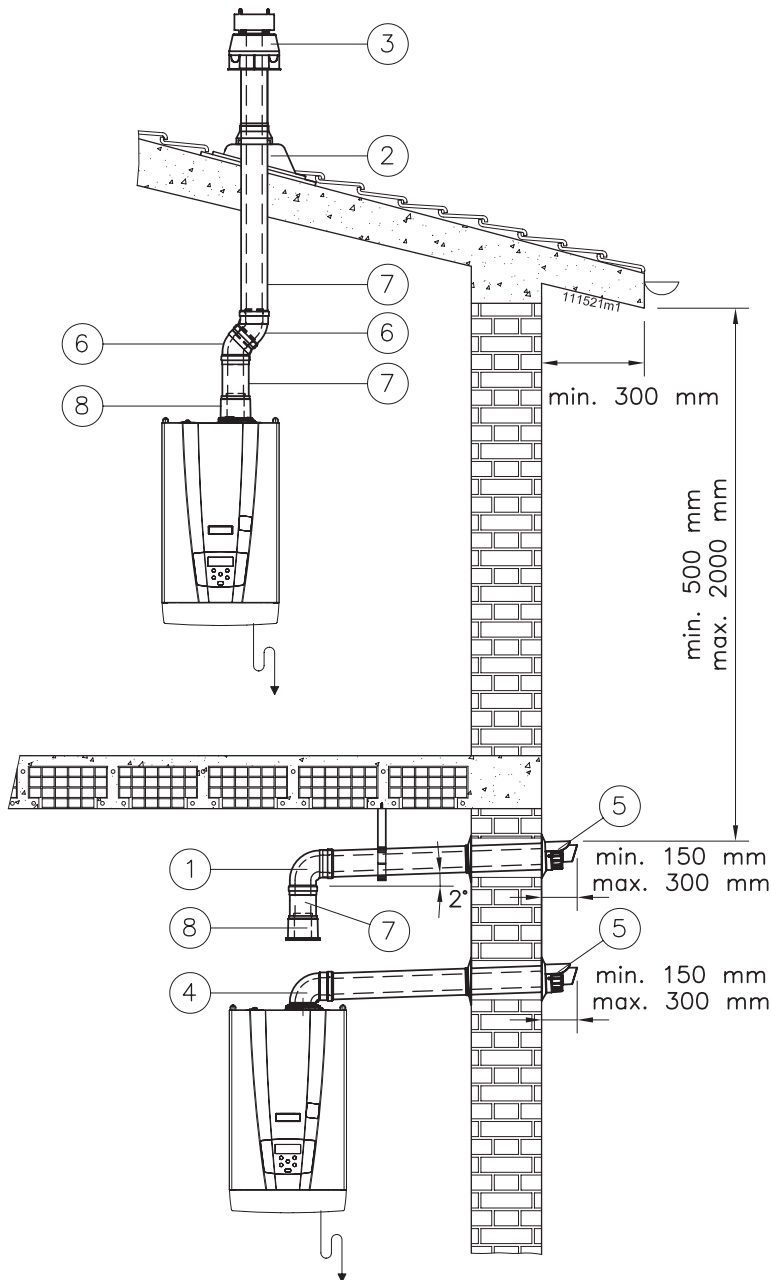


Figure 5-30 - Examples of coaxial pipe installations

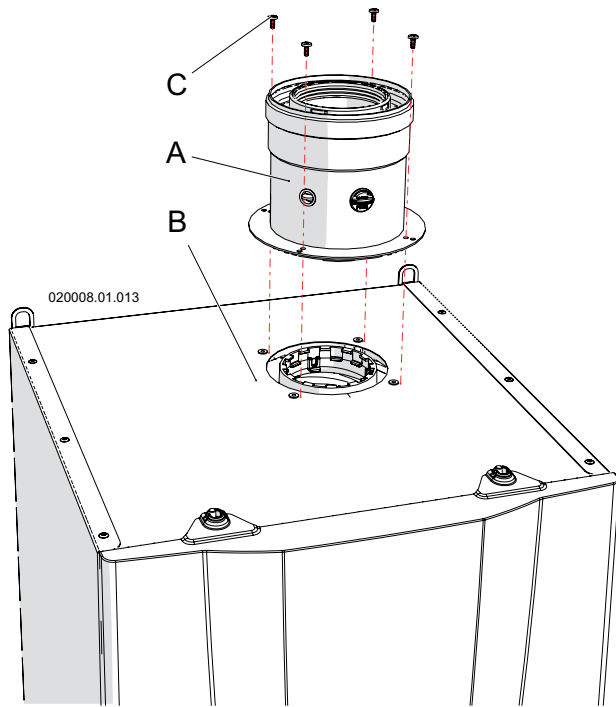


Figure 5-31 - Installation of vertical coaxial system

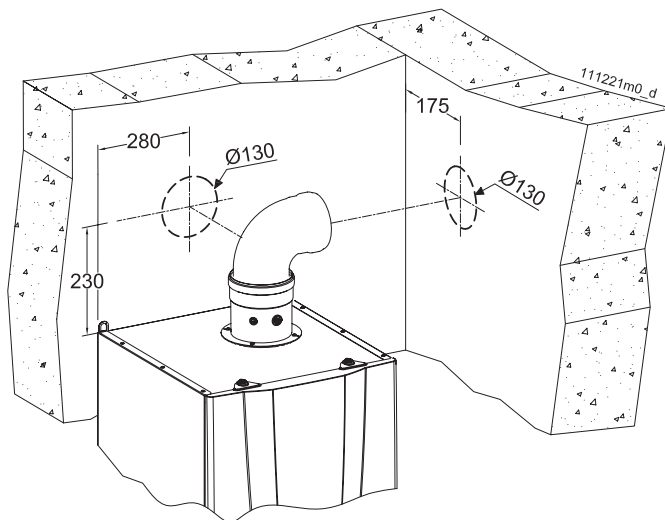


Figure 5-32 - Quotes and hole centre to centre distances for coaxial drain pre-installation

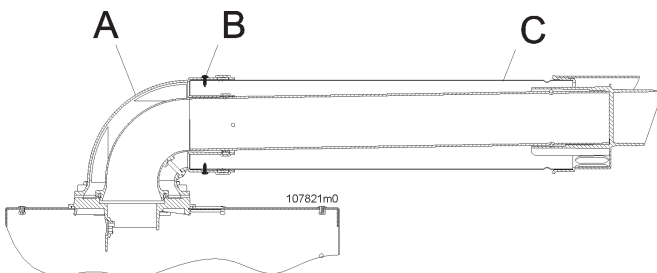


Figure 5-33 - Positioning the coaxial pipe

## 5.14.10 - "80/125PP vertical coaxial" System (polypropylene) (C13; C33)

### AGUADENS 37

The appliance is supplied as per standard without fittings for the connection of the fumes exhaust/air intake. To connect it to a vertical 80/125 system, the relevant kit must be requested and must be installed as in figure 5-31.



**ATTENTION !!!** Scrupulously follow the installation phases of the coaxial pipe as illustrated in figure 5-33. In particular:

- 1.- introduce the coaxial pipe "C" inside the bend "A";
- 2.- fix the external pipe using the stainless steel self-threading screws "B".



**ATTENTION !!!** The coaxial exhaust and intake pipes must be appropriately sustained via rigid brackets positioned no more than 1 metre from each other. The brackets must be fixed to rigid walls that can support the weight of the pipe itself.



**ATTENTION !!!** Once these operations have been performed, check that the exhaust/intake terminal is exposed to the outdoors with the tolerances given in figure 5-34.

☞ Take particular care with the installation of pipes in the part that passes through the wall to the outside. Normal maintenance operations must always be possible, therefore install the pipes in a sheath so that they can slide out.

☞ The horizontal exhaust flue pipes must always have an inclination of 2% with the fall back towards the appliances as opposed to the wall terminal.

☞ The combined exhaust/air intake pipe can be extended up to a maximum distance as indicated in the table in section 9 at the end of the manual. Every 90° bend has a loss equivalent to value on section 9. Every 45° bend has a loss equivalent to value on section 9.

## 5.14.11 - "80/125PP Coaxial" System: accessories available

The following accessories are available on request to make the 80/125 coaxial fumes exhaust/air intake system:  
(the number after the code is used to recall the piece in the following drawings)

62617255 - N° 2 converts for pitched roofs from 5° to 25° extension L = 1000 mm

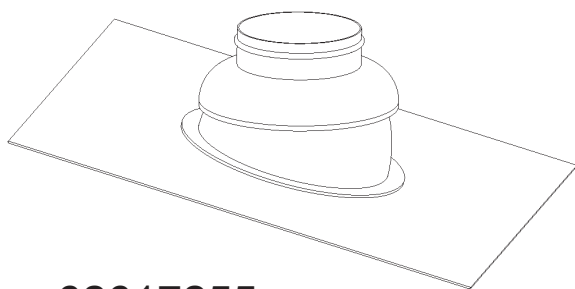
62617321 - N° 1 90° coaxial bend M/F PP

62617322 - N° 6 45° coaxial bend M/F PP

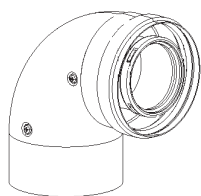
62617323 - N° 7 Coaxial extension L 1m PP

62617325 - N° 3 coaxial PP roof terminal

62617324 - N° 5 coaxial PP wall terminal



62617255



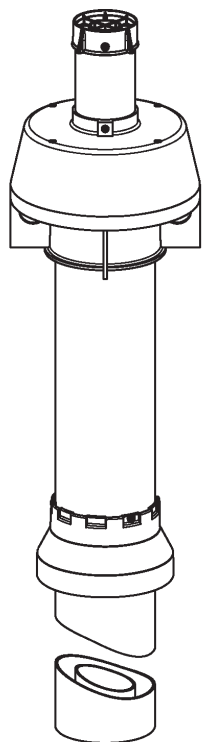
62617321



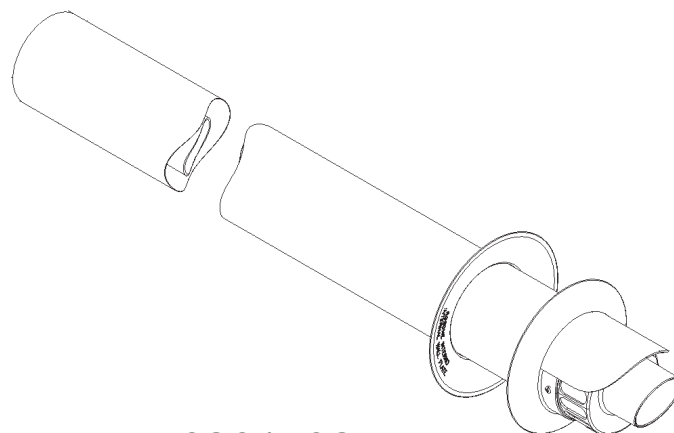
62617322



62617323



62617325



62617324

**5.14.12 - “80/125PP Coaxial” System: installation examples**

When a coaxial exhaust is made (see figure 5-34), both vertical and horizontal, the exhaust pipe slope upwards in a way to make the condensate flow into the appliance.



**ATTENTION !!!** The horizontal terminal must be protected against the accidental return of rain water. To do this, gables must be installed (or projections or balconies or relevant protections ) with the minimum dimensions given in figure 5-34.

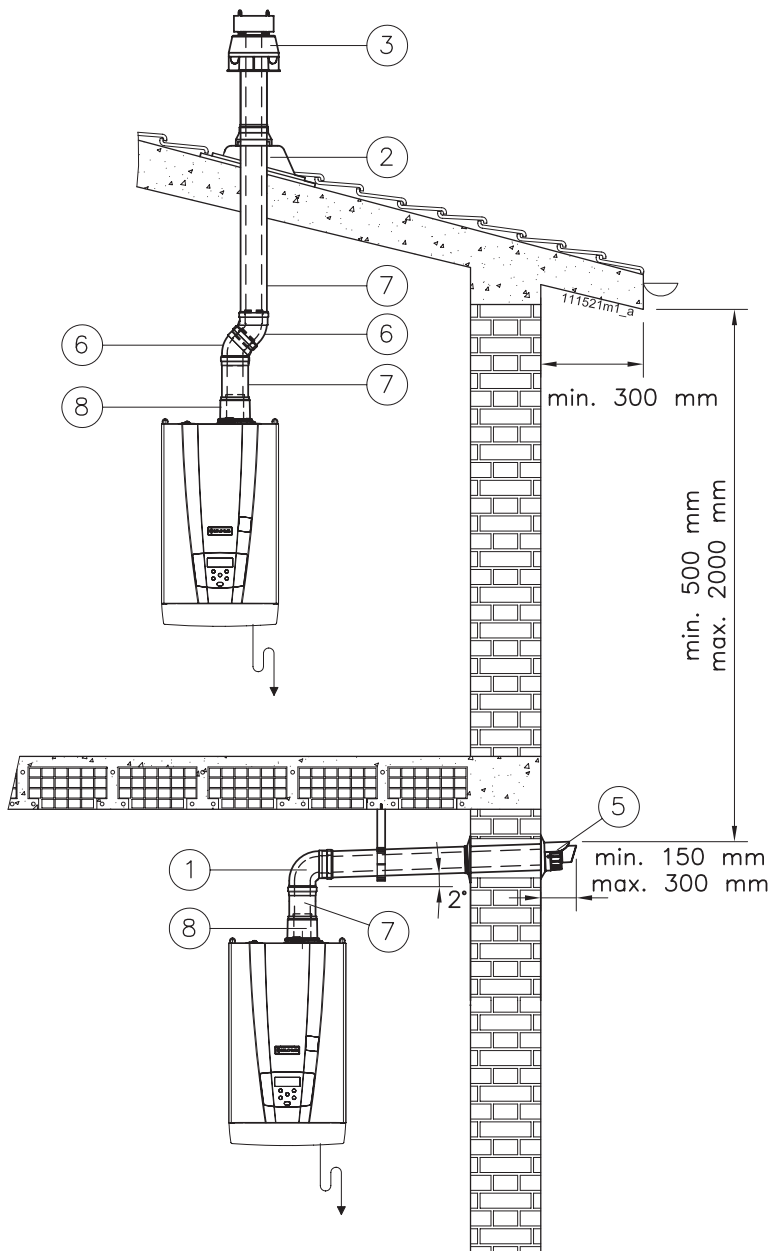


Figure 5-34 - Examples of coaxial pipe installations

## 6 - OPERATING

### 6.1 - Operating

Before starting the appliance up, it is necessary to carry out the following.

#### 6.1.1 - User instructions

Instruct the user regarding correct use of the appliance and the plant in general. In particular:

- ☞ Give the installation and user manual and all documentation contained in the packaging to the user.
- ☞ Instruct the user concerning the special measures for the exhaust of burned gases, informing them that they must not be modified.
- ☞ Inform the user regarding the correct adjustment of the temperatures settings.

#### 6.1.2 - Filling the condensate drain siphon

The siphon found inside the appliance (see figures 3-2 and 3-4 detail "40"), must be filled with water to create the water head able to prevent the fumes escaping from pipe "F" in figure 5-9. Proceed as follows to do this:

(refer to figure 6-1 for models 16 and 22 or figure 6-2 for model 37)

- 1.- loosen the screw "E";
- 2.- remove the lid "D" and the gaskets "C";
- 3.- introduce a rubber hose into the opening "B" (do not confuse with "A") and the other end of the hose into the funnel;
- 4.- use the funnel to slowly pour about 200 cm<sup>3</sup> (a glass) of water;
- 5.- re-mount everything in reverse order.

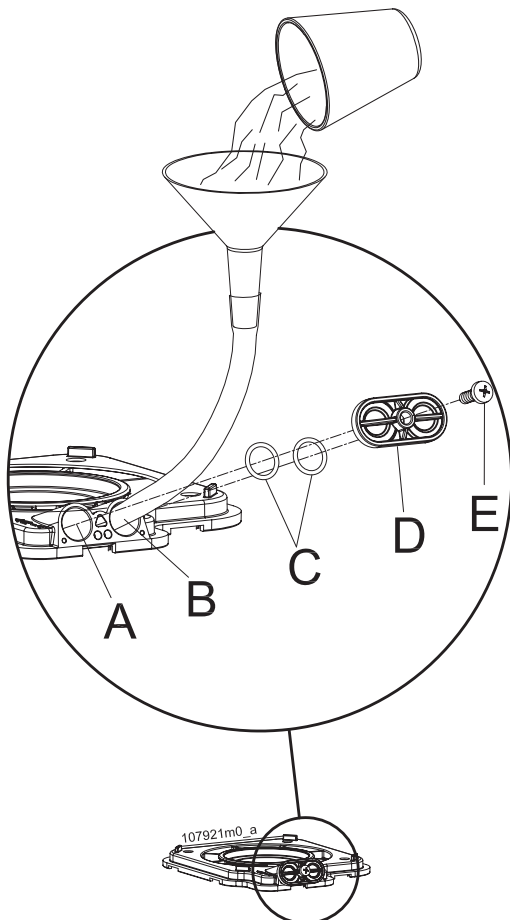


Figure 6-1 - Filling the condensate drain siphon on models 16 and 22



**ATTENTION !!!** If the appliance remains off for more than 3 months, the siphon must be filled again as explained above.

### 6.2 - General recommendations regarding the supply of gas

For commissioning of the appliance, have a professionally qualified technician perform the following checks:

- ☞ That the appliance is powered by the type of fuel for which it is set-up.
- ☞ That the gas supply pressure (with appliance operating and at a standstill) is within the maximum and minimum values indicated in the table in section 9 at the end of the manual.
- ☞ That the supply plant has all safety and control parts envisioned by the current national and local Standards.
- ☞ That the exhaust flue terminal discharge terminal and the combustion agent air intake terminal are free from any obstruction.
- ☞ That the exhaust flue terminal and combustion agent air intake terminal are positioned outside the building.
- ☞ That the condensate drain connection is connected.



**ATTENTION !!!** If you smell gas:

- A - Do not switch on any electric device, telephone included or any object that can cause sparks;**
- B - Immediately open doors and windows causing a current of air that quickly cleans the gas from the room;**
- C - From another room, or from a neighbour's, immediately call a professionally qualified technician or the gas supply company. Call the Fire Service if the former are not available.**

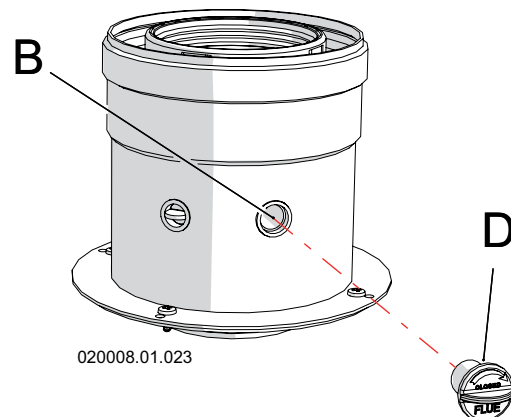


Figure 6-2 - Filling the condensate drain siphon on model 37

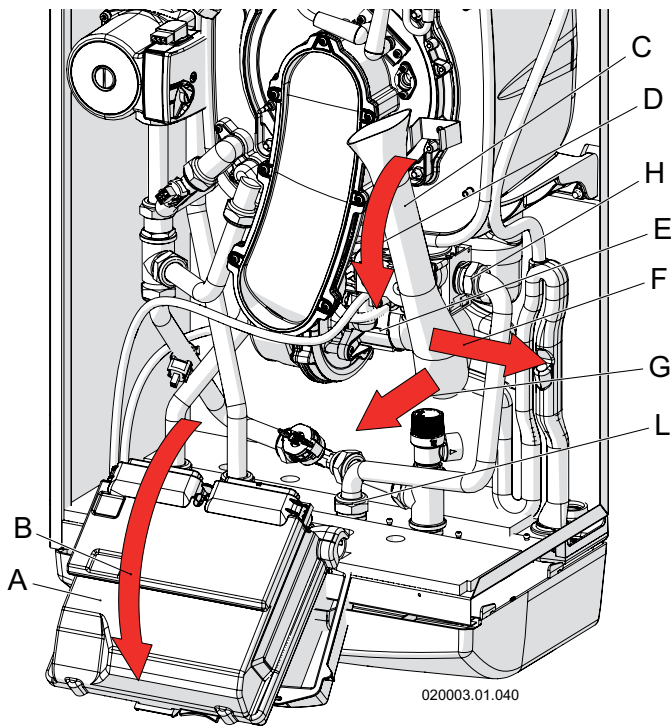


Figure 6-3 - Removing the air manifold

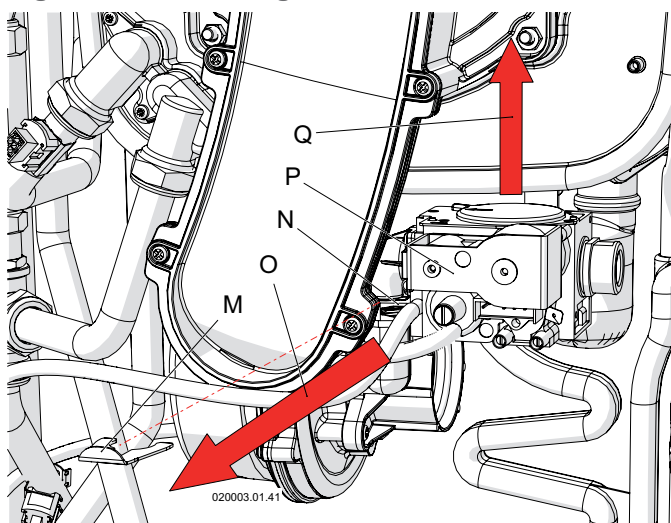


Figure 6-4 - Removing the gas valve

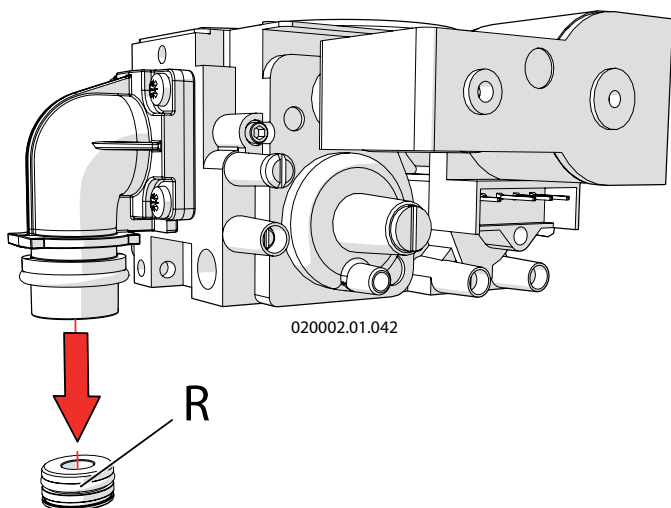


Figure 6-5 - Replacing the gas nozzle

### 6.3 - Type of gas for which the appliance is regulated.

There is a label on the front of the appliance certifying the gas supply type and pressure for which it is adjusted. The appliance may have the following 2 types of wording:

#### 2H-G20-20mbar NATURAL GAS

means that the appliance is adjusted to operate with H type gas of the second family (natural gas) at a supply pressure of 20 mbar.

#### 3P-G31-37mbar LP GAS

means that the appliance is adjusted to operate with type P gas (Propane, also called LP Gas) of the third family, at a supply pressure of 37 mbar.

### 6.4 - Conversion of the appliance from one type of gas to another



**ATTENTION !!!** Read these instructions carefully before changing the gas:

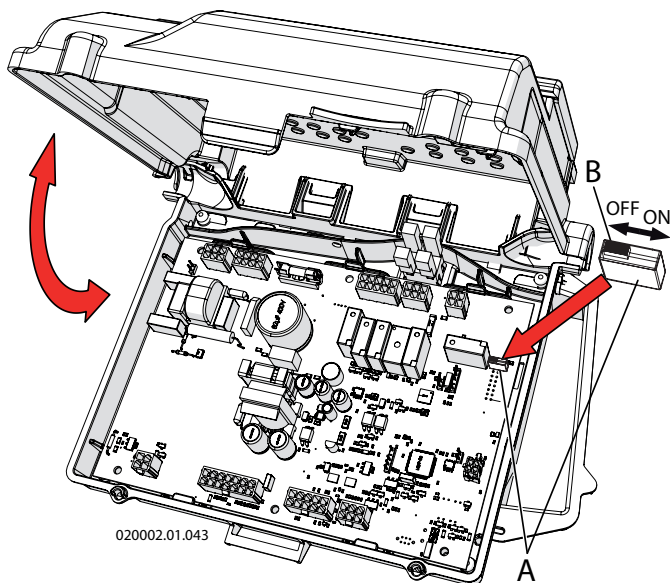
- The gas appliance must be installed, calibrated or modified by specialised staff in compliance with legal terms;
- Check and be certain that the type of gas which is powering the appliance is compatible with the adjustment kit in your possession;
- Do not power the appliance with gases different from those envisioned.

Follow the instructions given below to change the gas:

- 1 - disconnect the electric power supply upstream from the appliance;
- 2 - open the appliance casing as reported in section 8.2;
- 3 - access the control and command board as reported in section 8.2;
- 4 - move the microswitch "B" from left to right to the "ON" position (see figure 6-6);
- 5 - apply electric power to the appliance;
- 6 - the parameter **3001** will appear on the appliance's visual display, followed by its value;
- 7 - using the + and - keys, access the parameter **3002**;
- 8 - press the RESET key to make the **3002** parameter flash;
- 9 - using the + and - keys, set the value of the parameter **3002** to the new corresponding value according to the table in figure 6-8.
- 10 - press the RESET key to confirm the modification.
- 11 - remove voltage from the appliance, re-position the microswitch "B" from right to left in "OFF" position (see figure 6-6).
- 12 - close the gas supply;
- 13 - remove the air manifold making sure to turn it externally and then slide it out of the fan inlet (see figure 6-3, detail "C");
- 15 - remove the gas inlet pipe via the two fittings (see figure 6-3, details "H" and "L");
- 16 - remove the clamping spring "M" from the seat "N" releasing the valve "P" (See figure 6-4);



## 6 - OPERATING



B – Microswitch

Figure 6-6 - Positioning the microswitch

<b>A</b>	IT-FR-ES-PT-UK-IE-RO-HU
Apparecchio regolato per gas: Appareil réglé pour gaz: Aparato regulado por gas: Aparelho regulado por gas: Appliance set for gas type:	
2H-G20-20mbar 2E+-G20/G25-20/25mbar	
GAS METANO GAZ NATUREL GAS NATURAL GAS NATURAL NATURAL GAS	
<b>B</b>	IT-FR-ES-PT-UK-IE DE-BE-NL-RO-HU
Apparecchio regolato per gas: Appareil réglé pour gaz: Aparato regulado por gas: Aparelho regulado por gas: Appliance set for gas type: Apparat reguliert für gas: Toestel ingesteld voor gassoort:	
3B/P-G30/G31-30mbar 3P-G31-37mbar	
GAS GPL GAZ GPL GAS GLP GAS GLP LP GAS	
<b>C</b>	FR-DE-BE
Appareil réglé pour gaz: Apparat reguliert für gas: Appliance set for gas type:	
2Es-G20-20mbar 2E-G20-20mbar 2E(s)B-G20-20mbar	
GAS NATUREL (LACQ) ERDGAS E	
<b>D</b>	FR-DE-BE-NL
Appareil réglé pour gaz: Apparat reguliert für gas: Appliance set for gas type: Toestel ingesteld voor gassoort:	
2E(R)-G25-25mbar 2EI-G25-25mbar 2L-G25-25mbar 2LL-G25-20mbar	
GAS NATUREL (GRONINQUE) ERDGAS LL NATURAL GAS GRONINGEN	

Figure 6-7 - Labels certifying the new status of adjustment of the appliance

Model	Type of gas	Setting parameter <b>3002</b>	Gas supply minimum pressure (mbar)	Gas supply maximum pressure (mbar)	Gas nozzle diameter (mm)	CO2 Maximum power (%)	CO2 Minimum power (%)	O2 Maximum power (%)	O2 Minimum power (%)
16	G20	50	15	45	4,9	9,0 ± 0,3	8,5 ± 0,2	4,8 ± 0,2	5,5 ± 0,2
	G31	51	15	45	3,7	10,5 ± 0,3	10,0 ± 0,2	4,8 ± 0,2	5,6 ± 0,2
22	G20	52	15	45	6,5	9,0 ± 0,3	8,5 ± 0,2	4,8 ± 0,2	5,5 ± 0,2
	G31	53	15	45	4,7	10,5 ± 0,3	10,0 ± 0,2	4,8 ± 0,2	5,6 ± 0,2
37	G20	54	15	45	10,0	8,7 ± 0,3	8,3 ± 0,2	4,7 ± 0,2	5,4 ± 0,2
	G31	55	15	45	6,5	10,1 ± 0,3	10,8 ± 0,2	4,7 ± 0,2	5,8 ± 0,2

Figure 6-8 - Correspondence table for the parameter **3002** and the operating values

17. - slide the gas valve “P” out upwards;
18. - replace the gas nozzle “R” (see figure 6-5) with an appropriate one according to that stated in figure 6-8 under “Diameter of the gas nozzle”;
19. - remount the gas valve (see figure 6-4, detail “P”), making sure to reposition the spring “M”.
20. - remount the gas supply pipe via the two fittings (see figure 6-3, details “H” and “L”);
21. - remount the air manifold (see figure 6-3, detail “C”);
22. - open the gas isolation valve;
23. - check for gas leaks an all joints.

**ATTENTION !!!** Perform the gas leak test according to that established by the current Standard and only using soapy water. The use of naked flames is prohibited.

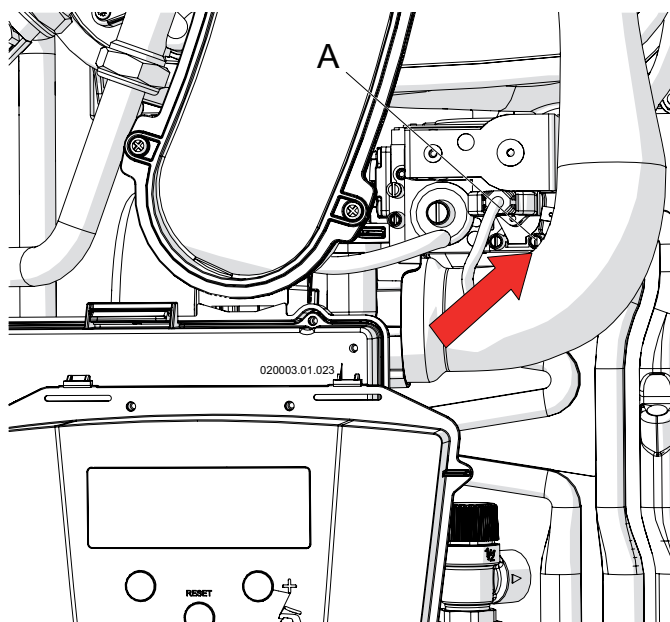
**ATTENTION !!!** If you smell gas:

**A** - Do not switch on any electric device, telephone included or any object that can cause sparks;

**B** - Immediately open doors and windows causing a current of air that quickly cleans the gas from the room;

**C** - From another room, or from a neighbour’s, immediately call a professionally qualified technician or the gas supply company. Call the Fire Service if the former are not available.

- 24.- check the supply gas pressure, following the procedure in section 6.6;
- 25.- open the CO2 adjustment screw completely (see figure 6-12 detail “A”);
- 26.- control and adjust the CO2, following the procedure in section 6.7;
- 27.- instead of the label that identified the old state of adjustment, apply the sticker onto the front casing of the appliance (see figure 6-7), certifying the appliance’s new state of adjustment, as follows: apply label “B” if the appliance has been converted from NATURAL GAS to LP GAS; apply label “A” if the appliance has been converted from LP GAS to NATURAL GAS.



A - Presa di pressione ingresso gas.

Figura 6-9 - Valvola del gas

### 6.5 - Ignition

- 1.- open the gas isolation valve;
- 2.- power the appliance electrically;
- 3.- adjust the temperature desired for the domestic hot water

service using the and keys. The icon , present on the display will inform regarding the operating state of the domestic hot water service:

- a) fixed icon: domestic hot water inactive (no-one is withdrawing domestic hot water, or in the case of a storage tank, the delivery temperature as been reached)
  - b) flashing icon: domestic hot water is being withdrawn.
- 4.- open the domestic hot water tap to the maximum to evacuate the air inside the water heater. If the water flow appears to be limited, open two or three taps to evacuate completely the air. On models 37 you can help by opening the manual air purge valve (see detail "47" of figure 3-4 )

### 6.6 - Check the gas supply pressure

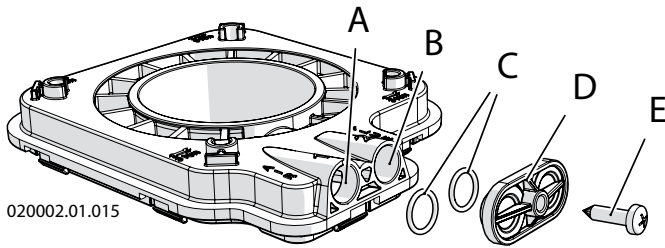
The gas supply pressure must correspond to that stated in the table in section 9 at the end of the manual.

For its verification, proceed as follows:

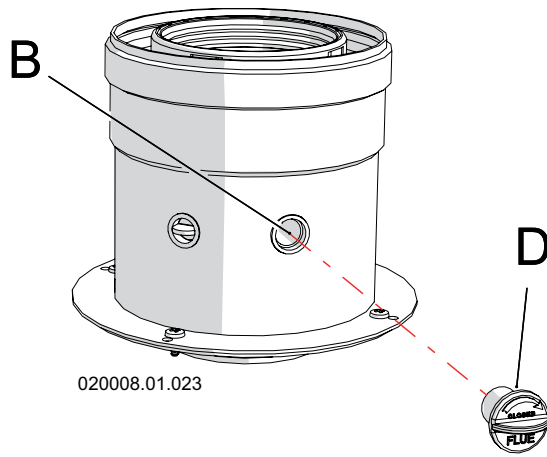
- 1.- close the gas supply manual valve;
- 2.- access the components inside the appliance, following the procedure in section 8.2;
- 3.- loosen the pressure port "A" (see figure 6-9);
- 4.- connect to a pressure gauge with resolution of at least 0,1 mbar (1 mmH<sub>2</sub>O);
- 5.- open the gas manual valve;
- 6.- check that the pressure does not exceed the value given in the table in section 9 under "gas supply maximum pressure";
- 7.- open the domestic hot water tap to maximum;
- 8.- wait for the temperature of the appliance to stabilise;
- 9.- check that the pressure does not drop to a lower value than the "gas supply minimum pressure" given in section 9. If the supply pressure does not respect the values described, operate upstream from the appliance in order to take it back within the minimum and maximum range;
- 10.- close the domestic hot water tap;
- 11.- close the pressure point "A" in figure 6-9;
- 12.- check for any gas leaks on port "A" in figure 6-9.



**CAUTION !!!** Perform the leak test using a soap and water only. The use of naked flames is prohibited.



020002.01.015  
**Figure 6-10 - Combustion analysis port on models 16 and 22**

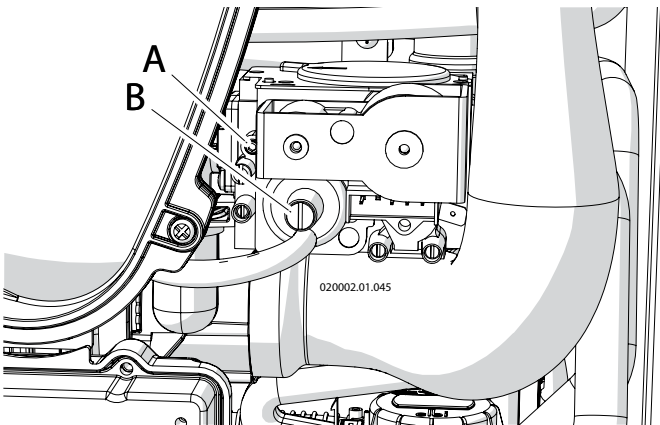


020008.01.023  
**Figure 6-11 - Combustion analysis port on model 37**

### 6.7 - Measurement and adjustment of CO2 levels

The appliance in normal operating condition and for altitudes within 1000 m, must have a CO2 (carbon dioxide) level in the exhaust flue gases within the parameters as detailed in section 9. A value which is different to those detailed can cause malfunctions and is strictly prohibited. Combustion analysis must be performed to check and eventually adjust this value. Proceed as follows:

- 1.- insert a combustion analyser on the appropriate point on the flue fitting "B" in figure 6-10 or 6-11;
- 2.- open the domestic hot water tap fully;
- 3.- wait for the CO2 measurement to stabilise;
- 4.- compare the value measured with that given in the table in figure 6-8, "CO2 maximum power". If the value measured is different from the value read, it must be taken back within the value given in the table in figure 6-8. proceeding as follows:
  - a) turn screw "A" (figure 6-12) clockwise to decrease the level of CO2;
  - b) turn screw "A" (figure 6-12) counter-clockwise to increase the level of CO2;
- 5.- once the check has been completed, seal the screw "A" in figure 6-12 with red paint or similar system;
- 6.- follow section 7.8 to enter parameter 2010 and set it to Lou;
- 7.- open a DHW faucet to draw some water;
- 8.- now appliance will fire at minimum capacity;
- 9.- wait for the CO2 measurement to stabilise;
- 10.- compare the value measured with that given in the table in figure 6-8, "CO2 minimum power";
- 11.- if the value is not into the range, use screw "B" as per figure to adjust the CO2 value. Rotate the screw counter-clockwise to reduce the CO2 value or clockwise to increase the CO2 value;
- 12.- once the check has been completed, seal the screw "B" in figure 6-12 with red paint or similar system;
- 13.- press the RESET key again to enter the parameter **20 10** and use the + and - keys, to modify the value to **OFF**;
- 14.- press the RESET key to confirm the modification.
- 15.- hold the RESET key down for 5 seconds to exit the "installer" menu.
- 16.- close the previously-opened domestic hot water tap.




A - High fire CO2 adjustment screw  
 B - Low fire CO2 adjustment screw

**Figure 6-12 - Gas valve**

### 6.8 - Self-learning and calibration of the minimum and maximum capacity output

This water heater have a self-learning procedure to reach the best water temperature tuning. In order to do this, the water heater automatically calibrate the maximum and minimum capacity based on the typical tappings. Because at the first installation it is not known what's the typical tappings, for an immediate satisfactory temperature tuning it is suggested to help the water heater in its self-learning. Operate as follows:

- 1.- open a hot water faucet to the maximum flow;
- 2.- using button , increase the value to the maximum water temperature;





**CAUTION!!! A domestic hot water temperature exceeding 51°C can cause permanent damages to persons, animals and objects. Children, the elderly and disabled must be protected against the potential risks of scalding, by introducing devices that limit the temperature of use of domestic hot water to utilities.**

- 3.- water heater should fire for at least five minutes, to its maximum capacity or to the maximum capacity of the system where it is installed
- 4.- now the maximum capacity is calibrated;
- 5 - enter installer menu (see procedure on section 7.8) and set parameter 2010 to LOu
- 6.- now burner will fire at minimum capacity. Wait at least five minutes;
- 7.- now the minimum capacity is calibrated;
- 8.- Turn OFF and ON the water heater (see section 7.10);
- 9.- close your hot water faucet;
- 10.- now water heater learned the first minimum and maximum limit of this installation and it will correctly tune the hot water temperature.

### 6.9 - Adjust the domestic hot water flow rate

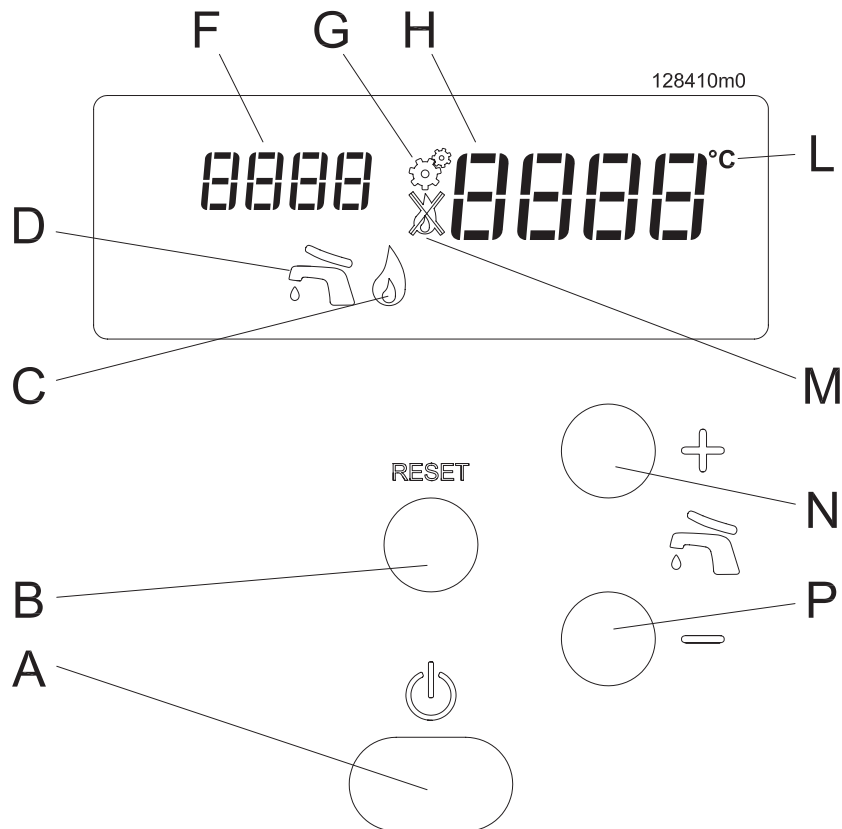
If the appliance is installed in a geographical area where the temperature of the cold water is very low, the flow rate of domestic hot water that passes inside the appliance may have to be reduced. It is therefore good practice to perform this adjustment:

- 1.- switch the appliance on;
- 2.- using the  and  keys, adjust the temperature of the domestic hot water to 48 - 50°C;
- 3.- open the domestic hot water tap fully. In the case of a single lever mixer, the position must be completely on "HOT";
- 4.- wait 3 minutes for the temperature to stabilise;
- 5 - if the water temperature is too cold, the flow rate must be reduced via the selector "3" in figure 5-10 (or something similar), until the desired temperature is reached.

### 6.10 - Check the capacity input

The heater has a factory-set air/gas ratio. The pressure of the gas at the burner is indirectly controlled by the blower. The only way to check the heater capacity input is operating directly on the gas meter. To do so proceed as follow:

1. turn the power switch (item "A" in Figure 7-1) to on;
2. gain access to the installer menu (see section 7.8) and set parameter 2010 to HIGH. Now heater will run at high fire for 20 minutes;
3. open a DHW faucet to the maximum flow;
4. measure the capacity input to the gas meter. This should match with the value given in technical data section 9 header "Maximum heat input" with a tolerance of +/- 10%;
5. if the capacity input is too low, check:
  - a) that there are no obstructions in the combustion air and/or vent system;
  - b) check that the flue and air intake length is below the maximum specified in the technical data, section 9;
  - c) check that heat exchanger and burner are clean (see section 8.4).



**Figure 7-1 - Control board**  
**Key for figure 7-1**

- A - On/off switch
- B - Reset Key
- C - Burner status (the burner is on when this icon is present)
- D - State of the domestic water service:  
 Icon off = domestic water off  
 Icon on = domestic water active but not operating  
 Icon flashing = domestic water active and operating
- F - Heating plant pressure or indicator of the various parameters inside the various menus
- G - Icon for entry into the "Installer" menu
- H - Domestic hot water temperature or indicator of the values assumed by the various parameters
- L - Unit of measurement of the temperature displayed
- M - Appliance blocked (see sections 7.9.1 and 7.9.2 for the diagnostics)
- N - Key for switching on and increasing the temperature of the domestic hot water or for scrolling and changing the value of the parameters
- P - Key for reducing the temperature of the domestic hot water (below minimum, the domestic hot water is switched OFF) or for scrolling and changing the value of the parameters

## 7.1 - Display

During operation the display shows the appliance operating state as well as other information as indicated in section 7.9 (Diagnostics). Other parameters can be consulted through the "User menu" (see section 7.7), which are useful for understanding operation of the appliance and to control the latest errors or lockout occurring.

After 5 minutes of normal operation, the display switches off completely to save energy. Just press any key to switch it back on.

In the case of any anomaly, the display switches back on automatically. This function can be modified by following section 7.6 (Energy saving).

## 7.2 - Ignition procedure

- 1.- open the gas manual valve;
- 2.- power the appliance electrically;
- 3.- adjust the temperature of the domestic hot water as per section 7.4.

4.- open a DHW faucet.

The command and control equipment will switch the burner on. If ignition does not take place within 20 seconds, (the appliance automatically re-attempts ignition 3 times), the appliance

blocks and the visual display will show **L 0 0 I**.

Press the RESET key to restore the normal operating conditions.

The appliance will automatically attempt a new ignition.



**CAUTION !!!** If shutdown due to blocking is repeated frequently, contact a qualified technician to reset the normal operating conditions.





### 7.3 - "User menu"

Entry into the "User menu" is highlighted by the visual display "F", in figure 7-1, which indicates parameters that can assume

values from **100 1** to **1999**. To enter the "User menu":

1.- hold the RESET key down for 2 seconds until the visual

display "F" shows **100 1**;

2.- press the  + and  - keys to scroll the parameters situated inside the user menu;



3.- hold down the RESET key for more than 2 seconds to exit the "User menu";

If no key is pressed for more than 60 seconds, the menu is exited automatically.

The parameters in section 7.7 can be queried in this menu.

### 7.4 - Adjustment of the domestic hot water temperature

The temperature of the domestic hot water is adjusted by

operating on the  + and  - keys. On pressing one of the two keys, the visual display "H" in figure 7-1 will start to flash and show the temperature that is being set. The range of adjustment for the temperature of the domestic hot water goes from 40°C to 60°C. For higher output temperatures, contact your technician to change the maximum output temperature factory setting, see section 11.

### 7.5 - Timings of the various functions

To preserve the life of the appliance, improve the generated comfort and increase energy savings, have been inserted timings during operation. These timings are:

- Post circulation pump: each time ending on the domestic service, the pump continues to operate for 40 seconds;
- Anti-block pumps: every 24 hours is a forcing of the recirculation pump and of the additional storage tank charging pump (if present);
- Anti-legionella; if the appliance is connected to a storage tank for the D.H.W. production, every seven days, this latter is forced, to temperature of 60°C to perform disinfection against the bacterium of the legionella. This function turns ON even after two hours that the appliance has been electrically powered.

### 7.6 - Display Energy Saving mode

To reduce the consumption of display energy, it will switch off automatically after 5 minutes from the last operation performed. This function can be deactivated or the time modified via parameter **2 100** present in the "Installer menu" (see section 7.8). If the parameter is set at **OFF**, the display will remain on constantly.

## 7 - USE

### 7.7 - “User menu” Parameters

To access the “User menu” follow that reported in section 7.3.

The following parameters can be queried in this menu:

Parameter	Parameter Description	M.U.
1001	Heat exchanger outlet temperature 1	°C
1002	Hot water outlet temperature or storage tank temperature (if any)	°C
1003	No function	/
1004	External temperature (visible when an external temperature sensor is installed) (N/A)	(N/A)
1005	Heat exchanger outlet temperature 2 (safety sensor)	°C
1006	Exhaust flue temperature	°C
1007	Cold water inlet temperature	°C
1008	Ionisation current	uA
1009	Status of the pump inside the appliance	ON/OFF
1010	Status of the central heating side diverter valve (OFF = in central heating mode; ON = in domestic hot water mode) (N/A)	(N/A)
1011	Status of the central heating side diverter valve (ON = in D.H.W. mode; OFF = in central heating mode) (N/A)	(N/A)
1012	Central heating supply temperature calculated via the external sensor (N/A)	(N/A)
1013	Status of the timer contact (N/A)	open or closed
1014	Exhaust flue temperature 2 (safety sensor) (N/A)	(N/A)
1040	Current rotation speed of the fan	rpm
1041	Fan rotation speed on ignition	rpm
1042	Fan rotation speed in minimum power mode	rpm
1043	Fan rotation speed in maximum power mode	rpm
1051	Latest block condition recorded (Loc) (see section 7.9.1) (255 means no block)	/
1052	Latest error condition recorded (Err) (see section 7.9.2) (255 means no error)	/
1053	Number of times the burner has lost the flame	n°
1055	Number of failed burner ignitions	n°
1056	Number of hours worked in central heating mode (N/A)	(N/A)
1057	Number of hours worked in domestic hot water mode	h x 10
1058	Number of burner working days	days
1059	Interval of time between the last two blocking errors (Err)	! : value in minutes; e! : value in hours; 3 : value in days; 4 : value in weeks;
1060	Interval of time between the last two blocks (Loc)	
1061	Current rotation speed of the domestic hot water turbine (N/A)	(N/A)
1062	Current domestic hot water flow rate (Meter have a tolerance of +/- 15%)	l/min

N/A = Not applicable



## 7.8 - “Installer menu” & parameters



**ATTENTION !!! The modification of these parameters could cause the appliance, and therefore the plant, to malfunction. For this reason only a technician that has the awareness and in-depth knowledge of the appliances can modify them.**

The appliance command and control board makes this parameter menu available to the technician for the analysis of operation and adaptation of the appliance to the plant. Proceed as follows to enter the “Installer menu”:

1.- hold the RESET and keys down simultaneously for 5 seconds until the **2001** parameter is displayed.

The symbol appears on the display to indicate the entry into the “Installer menu”.

2.- the + and - keys can be used inside the menu to scroll the parameters;

3.- once the parameter of interest has been displayed, it can be modified as follows:

a.- press the RESET key to access the parameter (the visual display “H” in figure 7-1 will start to flash);

b.- modify the value of the parameter using the + and - keys;

c.- press the RESET key to confirm the data modified and go back to the list of parameters;

4.- To exit the “Installer menu”, hold down the RESET key

for 5 seconds until the symbol disappears from the display.

If no key is pressed for more than 5 minutes, the menu is exited automatically. Any data variation that is not confirmed with the RESET key will be lost.



**ATTENTION !!! Any variation to the parameters must be noted in the “Customised values” column present in the following table in order to facilitate the eventual replacement of the command and control board.**

The following parameters can be changed or queried in this menu:

Parameter	Parameter Description	M.U.	Setting range	Factory value	Customised values
2001	Central heating minimum power level (N/A)	(N/A)	(N/A)	1	(N/A)
2002	Central heating maximum power level (N/A)	(N/A)	(N/A)	100	(N/A)
2003	Central heating operating mode (N/A)	(N/A)	(N/A)	0	(N/A)
2004	Stand-by time after maximum differential (N/A)	(N/A)	(N/A)	10	(N/A)
2005	Post-circulation in central heating mode (N/A)	(N/A)	(N/A)	120	(N/A)
2010	Forcing of fan and burner (Water heater will work only in presence of demand of DHW)	/	OFF = No forcing FAN = Forcing of fan only to max speed LOu = Forcing of burner to minimum power lgn = Forcing of burner to ignition power HlgH = Forcing of burner to maximum power rEg = Forcing of burner to maximum power	OFF	
2011	Forcing the pump (N/A)	(N/A)	On = Pump on OFF = Pump off	OFF	(N/A)
2012	Forcing of the domestic central heating side diverter valve (N/A)	(N/A)	(N/A)	OFF	(N/A)
2013	Forcing of the domestic hot water side diverter valve (N/A)	(N/A)	(N/A)	OFF	(N/A)
2014	Icons test on the display. By pressing the REST key, all of the icons on the display light up. By pressing the RESET key again to display goes back to normal operation	/	/	/	
2020	Climatic adjustment: external temperature for central heating switch-off (N/A)	(N/A)	(N/A)	22	(N/A)
2021	Climatic adjustment: design external temperature (winter) (N/A)	(N/A)	(N/A)	-5	(N/A)
2022	Climatic adjustment: supply temperature corresponding to the design external temperature (winter) (N/A)	(N/A)	(N/A)	80	(N/A)
2023	Climatic adjustment: external spring-like temperature (N/A)	(N/A)	(N/A)	20	(N/A)

## 7 - USE

2024	Climatic adjustment: supply temperature corresponding to the external spring-like temperature (N/A)	(N/A)	(N/A)	40	(N/A)
2027	Temperature reduction by room thermostat opening (N/A)	(N/A)	(N/A)	10	(N/A)
2040	Climatic adjustment: central heating boost temperature (N/A)	(N/A)	(N/A)	0	(N/A)
2041	Climatic adjustment: central heating boost time (N/A)	(N/A)	(N/A)	20	(N/A)
2042	Protection against frequent switch-on in central heating mode: time (N/A)	(N/A)	(N/A)	180	(N/A)
2043	Protection against frequent switch-on in central heating mode: temperature differential (N/A)	(N/A)	(N/A)	16	(N/A)
2060	Domestic hot water minimum power level	%	From 1 to 50	1	
2061	Domestic hot water maximum power level	%	From 1 to 100	100	
2062	Post-circulation in domestic hot water mode	sec	From 10 to 900	40	
2063	Maximum time for loading storage tank (N/A)	(N/A)	(N/A)	60	(N/A)
2064	Number of flow meter revs. for every litre of water (N/A)	(N/A)	(N/A)	3,2	(N/A)
2066	Delay in the detection of the instantaneous domestic hot water	sec	From 1 to 10	1	
2067	Storage tank loading procedure (N/A)	/	0 = (N/A); 1 = (N/A); 2 = ON, the domestic hot water always has priority over heating;	2	
2080	Periodic maintenance meter (after RESET, the meter automatically goes back to ON)	/	ON = Periodic maintenance meter active; OFF = Periodic maintenance meter off; RESE = Meter reset	OFF	
2081	Periodic maintenance meter: maintenance request time	days	From 0 to 1000	1000	
2100	Energy saving display	min	OFF = display always on From 1 to 30 = delay to switch-off in minutes.	5	

### 7.9 - Diagnostics

During normal operation of the appliance, the visual display in figure 7-1 continuously shows the state of work of the appliance, via the following indications:

Parameter	Parameter Description	Display on visual display "H" in figure 7-1
<i>AFro</i>	Anti-freeze function active	Appliance temperature (°C)
<i>Loc</i>	Appliance blocked. To reset, press <b>RESET</b> . If the block occurs frequently, contact a professionally qualified technician	Lockout code (see section 7.9.1 for decode)
<i>Err</i>	Appliance in error mode. Functioning can only be restored by solving the cause of the anomaly. Contact a professionally qualified technician	Error code (see section 7.9.2 for decode)
<i>ALe9</i>	Anti-legionella function running (see section 7.5). It will end on reaching the water temperature of 60°C inside the storage tank.	Storage tank temperature (°C)
<i>SEr</i>	Maintenance request for the appliance	Appliance temperature (°C)

### 7.9.1 - Diagnostics “Loc” block fault codes and potential solution

Block	Block Description	Checks	Solutions
Loc 0	Internal memory error E2prom at command board		Replace the command and control board.
Loc 1	1 No flame detection after three successive ignition attempts.	Control: Supply gas pressure (see section 6.6), sparks on the ignition electrodes (see section 8.6); 230Vac electric power supply to the gas valve; electric resistance of the two gas valve coils of 0,88 Kohm and 6,59 Kohm  If the burner switches on and switches off at the end of the ignition attempt, check: that the ionisation current is at a value over 4 (follow the procedure in section 8.13)	the supply pressure is not correct, operate upstream from the appliance to restore it; If the current at the gas valve is not 230Vac, the command and control board must be replaced. If the electric resistance of the gas valve is not 0,88 Kohm and 6,59 Kohm, the valve must be replaced.  If the ionisation current is not over 4, the CO2 must be checked (follow section 6.7) and restore its correct value, check the ionisation electrode and replace it if necessary. Check the integrity of the ionisation current electric circuit cables.
Loc 2	Gas valve command relay broken		Replace the command and control board.
Loc 3	Internal safety relay failure at command board		Replace the command and control board.
Loc 4	Appliance in error mode for more than 20 hours	Control the last error displayed in the board.	Operate according to the last error displayed.
Loc 5	Fan out of speed for more than 60 seconds	Check that it is powered at 300 Vdc.	If the fan is powered, it must be replaced, alternatively replace the command and control board.
Loc 6	Fan error too slow		
Loc 7	Fan error too fast		
Loc 8	Parameters inside the E2prom memory, incorrect		Replace the command and control board.
Loc 9	Software error inside the command board		Replace the command and control board.
Loc 10	Software error inside the command board		Replace the command and control board.
Loc 11	Software error inside the command board		Replace the command and control board.
Loc 12	Software error inside the command board		Replace the command and control board.
Loc 13	Not applicable	(N/A)	(N/A)
Loc 14	Not applicable	(N/A)	(N/A)
Loc 15	Appliance has reached the maximum temperature of operation	Check that the pump works;  Check that the electrical resistance of the two sensors 1001 and 1005 combine with the chart referred to in section 8.14;  Check that the high limit flue gas temperature fuse has not been involved;  Check air is purged from water heater (see section 6.5);	Restore the flow of water or replace the control board;  If either or both of the sensors are not within correct values, replace sensor;  If the high limit flue gas temperature fuse has been involved (the contact is open) before replacing the high limit verify the temperature of the flue gas referred to in the technical data from section 9; <b>CAUTION!!! If the temperature is not within the correct value DO NOT ATTEMPT ANY REPAIR but contact the manufacturer.</b>

## 7 - USE

Loc 16	Exhaust flue maximum temperature. <b>ATTENTION !!! If the block is repeated more than once a day, turn off the appliance and contact a qualified service center. NOT GROPE TO RESTORE.</b>	Check that the pump is operating correctly;  Measure that appliance performance; it must correspond to that declared in the technical features.  Check air is purged from water heater (see section 6.5)	If the pump does not operate, it must be replaced.  If the appliance is under-performing, the primary heat exchanger might be dirty either on the exhaust flue side or the domestic water side or both. Follow instructions in section 8.4 and check again.
Loc 17	Software error inside the command board		Replace the command and control board.
Loc 18	Software error inside the command board		Replace the command and control board.
Loc 19	Software error inside the command board		Replace the command and control board.
Loc 20	Flame still present 10 sec. after closing gas valve		Replace the gas valve or the command and control board.
Loc 21	Flame present before ignition		Replace the gas valve or the command and control board.
Loc 22	Flame lost three times	Control: that the ionisation current is at a value over 4 (follow the procedure in section 8.13)  Control: that the exhaust flue system is not being affected by high gusts of wind or nearby mechanically operated fans	If the ionisation current is not over 4, the CO2 must be checked (follow section 6.7) and restore the correct value. Check the ionisation electrode and replace it if necessary. Check the integrity of the ionisation current electric circuit cables.  If a horizontal exhaust flue terminal is exposed to unusually high wind conditions or nearby mechanically operated fans then a suitable deflection shield or protection should be considered or an alternative location should be considered. The same approach should be taken for a vertical exhaust flue and in addition, check that downdraughts are not being encountered due to the proximity of higher roof profiles.
Loc 23	Not applicable	(N/A)	(N/A)
Loc 24	Not applicable	(N/A)	(N/A)
Loc 25	1001 and 1005 sensors measure the different temperatures for more than 60 seconds.	Check that the electrical resistance of the two sensors match the graphics in section 8.14;	If one of the two or both sensors do not have correct values, they must be replaced;
Loc 26	Not applicable	(N/A)	(N/A)
Loc 27	Not applicable	(N/A)	(N/A)
Loc 28	Not applicable	(N/A)	(N/A)
Loc 29	Software error inside the command board		Replace the command and control board.
Loc 30	Software error inside the command board		Replace the command and control board.
Hot water temperature is not stable		Repeat calibration procedure (see section 6.8)  Check if pump is in speed 3	
Water flow is present but the water heater doesn't work		Check if the water flow (parameter 1062) is higher than the minimum water flow as stated on section 7.7.	

N/A = Not applicable

### 7.9.2 - Diagnostics “E” error fault codes and potential solutions










Error	Error Description	Checks	Solutions
Err 100	Software error inside the command board		Replace the command and control board.
Err 101	Software error inside the command board		Replace the command and control board.
Err 102	Software error inside the command board		Replace the command and control board.
Err 103	Software error inside the command board		Replace the command and control board.
Err 104	Software error inside the command board		Replace the command and control board.
Err 105	The supply temperature exceeds 110°C with the gas valve closed	<p>Check that the electrical resistance of the two supply sensors match the graphics in section 8.14.</p> <p>Check that the gas valve closes the gas correctly when the burner switches off.</p>	<p>If one of the two sensors does not match, the double supply sensor must be replaced.</p> <p>The gas valve must be replaced if it does not close correctly.</p>
Err 106	Software error inside the command board		Replace the command and control board.
Err 107	Software error inside the command board		Replace the command and control board.
Err 108	Software error inside the command board		Replace the command and control board.
Err 109	Software error inside the command board		Replace the command and control board.
Err 110	Software error inside the command board		Replace the command and control board.
Err 111	Software error inside the command board		Replace the command and control board.
Err 112	Software error inside the command board		Replace the command and control board.
Err 113	Software error inside the command board		Replace the command and control board.
Err 114	Flame detected in a moment when it should not be present		Replace the gas valve.
Err 115	Central heating water low pressure (N/A)	(N/A)	(N/A)
Err 116	Central heating water pressure sensor error (N/A)	(N/A)	(N/A)
Err 117	Not applicable	(N/A)	(N/A)
Err 118	Software error inside the command board		Replace the command and control board.
Err 119	Cold water inlet sensor (1007) circuit open	Check that the electric resistance of the sensor matches the graphics in section 8.14. Check the electric cables for connection between the sensor and the command board.	If the electric resistance does not match, replace it. The electric circuit must be repaired if it is damaged. Without either of the two previous cases, replace the command and control board.
Err 120	Heat exchanger outlet sensor (1001) circuit open	Check that the electric resistance of the sensor matches the graphics in section 8.14. Check the electric cables for connection between the sensor and the command board.	If the electric resistance does not match, replace it. The electric circuit must be repaired if it is damaged. Without either of the two previous cases, replace the command and control board.
Err 121	Heat exchanger outlet sensor (1005) circuit open	Check that the electric resistance of the sensor matches the graphics in section 8.14. Check the electric cables for connection between the sensor and the command board.	If the electric resistance does not match, replace it. The electric circuit must be repaired if it is damaged. Without either of the two previous cases, replace the command and control board.

## 7 - USE

Err 122	Domestic hot water outlet sensor (1002) circuit open	Check that the electric resistance of the sensor matches the graphics in section 8.14. Check the electric cables for connection between the sensor and the command board.	If the electric resistance does not match, replace it. The electric circuit must be repaired if it is damaged. Without either of the two previous cases, replace the command and control board.
Err 123	Flue gas sensor (1006) circuit open	Check that the electrical resistance of the sensor matches the graphics in section 8.14  Check that the wires between the board and the sensor are connected correctly	If the sensor does not match, the double exhaust sensor must be replaced.  If the wires are not connected correctly, the connections must be restored.
Err 124	Not applicable	(N/A)	(N/A)
Err 125	Not applicable	(N/A)	(N/A)
Err 126	Cold water inlet sensor (1007) circuit, in short circuit condition	Check that the electric resistance of the sensor matches the graphics in section 8.14. Check the electric cables for connection between the sensor and the command board.	If the electric resistance does not match, replace it. The electric circuit must be repaired if it is damaged. Without either of the two previous cases, replace the command and control board.
Err 127	Heat exchanger outlet sensor (1001) circuit, in short circuit condition	Check that the electric resistance of the sensor matches the graphics in section 8.14. Check the electric cables for connection between the sensor and the command board.	If the electric resistance does not match, replace it. The electric circuit must be repaired if it is damaged. Without either of the two previous cases, replace the command and control board.
Err 128	Heat exchanger outlet sensor (1005) circuit, in short circuit condition	Check that the electric resistance of the sensor matches the graphics in section 8.14. Check the electric cables for connection between the sensor and the command board.	If the electric resistance does not match, replace it. The electric circuit must be repaired if it is damaged. Without either of the two previous cases, replace the command and control board.
Err 129	Domestic hot water outlet sensor (1002) circuit, in short circuit condition	Check that the electric resistance of the sensor matches the graphics in section 8.14. Check the electric cables for connection between the sensor and the command board.	If the electric resistance does not match, replace it. The electric circuit must be repaired if it is damaged. Without either of the two previous cases, replace the command and control board.
Err 130	Flue gas sensor (1006) circuit in short circuit condition	Check that the electrical resistance of the sensor matches the graphics in section 8.14  Check that the wires between the board and the sensor are connected correctly	If the sensor does not match, the double exhaust sensor must be replaced  If the wires are not connected correctly, the connections must be restored
Err 131	Not applicable	(N/A)	(N/A)
Err 132	External temperature sensor circuit (1004) in short circuit condition (N/A)	(N/A)	(N/A)
Err 133	Not applicable	(N/A)	(N/A)
Err 134	Not applicable	(N/A)	(N/A)
Err 135	Phase neutral reversed error	(N/A)	(N/A)
Err 200	Not applicable	(N/A)	(N/A)
Err 201	Not applicable	(N/A)	(N/A)
Err 202	Not applicable	(N/A)	(N/A)
Err 203	Too high difference between supply and return sensor	(N/A)	(N/A)

N/A = Not applicable

### 7.10 - Switch ON and OFF the appliance

To switch Off the appliance press in the same time the  + and  - keys and  will appear then press  - key and **OFF** will appear; Press RESET key to confirm the **OFF** state. To switch back ON the appliance press in the same time the  + and  - keys and **OFF** will appear. Then press  + key and  will appear; press RESET key to confirm the  state.



## 8 - MAINTENANCE

### 8.1 - Care and maintenance

This section must be brought to the attention of the user by the installer so that the user can make the necessary arrangements with a qualified service agency for the periodic care and maintenance of the heater.

The installer must also inform the user that the lack of proper care and maintenance of this heater and any fuel burning equipment may result in an hazardous condition.

Installer should discuss contents of section 7 (User's section) with the user.

A trained and qualified service technician should perform the inspection listed in these instructions (see figure 8-1) each year.



**CAUTION !!! Appliance maintenance must only be performed by a professionally qualified technician.**



**CAUTION !!! Before every maintenance operation, disconnect the appliance from the electric power supply, using the relevant switch in the vicinity.**



**CAUTION !!! Close the manual gas valve before any maintenance operation**

#### Service and maintenance schedules

##### Service Technician

###### Annual Startup:

- Address reported problems (Follow section 8.1.2);
- Check all piping for gas leaks (Follow section 8.1.3)
- Verify flue and air lines in good condition and sealed tight (Follow section 8.1.4);
- Check water pressure/system piping (Follow section 8.1.5);
- Check control settings (Follow section 8.1.6);
- Check wiring and connections (Follow section 8.1.7);
- Check flame signal (Follow section 8.6);
- Inspect combustion chamber. Clean and vacuum if there's presence of debris and/or products of the combustion (Follow section 8.4).
- Inspect thermal insulations inside the combustion chamber and replace them if they are cracked or damaged (Follow section 8.3.1)
- Clean condensate siphon and fill with fresh water (Follow section 8.5).
- Check the capacity input (Follow section 6.10).

Figure 8-1 - Service and Maintenance Schedules

#### 8.1.1 - Service recall

In order to maintain maintenance frequency, the parameter

**2080** is present in the installer menu (see section 7.8), which is used to activate the maintenance call (Service)

along with parameter **2081** which is used to set the operating days which must pass between one intervention and the next. The control system identifies the operating days, verifying the burner activity time.

Proceed as follows to activate the call service:

1.- access the Installer menu (see section 7.8) and set

parameter **2080** on **01**;

2.- access parameter **2081** and set the appliance operating days which must pass between one call and the next.

The call will be completed with **SER** on the display. To remove the indication **SER** and renew the call period, operate as follows:

1.- access the "Installer menu";

2.- access the parameter **2080**, set it on **RESE** and press the RESET key.

3.- exit the Installer menu by pressing the RESET key for 5 seconds.

The call time is now renewed and **SER** appears on the display.

#### 8.1.2 - Address reported problems

Inspect any problems reported by the owner and correct before proceeding.

#### 8.1.3 - Check all piping for gas leaks

1. Inspect all gas piping and verify to be leak free.

2. Check for gas leaks: using soap solution, check for gas leaks from meter to appliance including all pipes and fittings and heater connection. Use liquid soap solution for all gas testing.



**CAUTION !!! Do not check for gas leaks with an open flame. Use the bubble test. Ignoring the bubble test or check for gas leaks with an open flame can cause explosion, severe personal injury, death, or substantial property damage.**

#### 8.1.4 - Verify flue and air lines in good condition and sealed tight;

1. Check for obstruction, condensation, corrosion and physical damage, water stains, any signs of rust, other corruptions or separation of the vent and air intake piping.

2. Check outside terminations. Screens and louvers should be free of any debris and must be cleaned as required.

#### 8.1.5 - Check system water pressure/ system piping/expansion tank;

1. Check water piping and accessories for leaks. Slightest leaks should be corrected.

2. Check the system to be full of water and pressure to remain stable at correct setting on gauge.



**CAUTION !!! Eliminate all system or heater leaks. Continual fresh makeup water will reduce heater life. Minerals can build up in sections, reducing heat transfer, overheating heat exchanger, and causing heat exchanger failure. Leaking water may also cause severe property damage.**

#### 8.1.6 - Check control settings

1. Set heaters setpoint low enough to end call for heat (see section 7.4. Gas valve should close and burner should stop firing. Fan will go into a post purge, then shuts off.

2. Control Safety Shutdown test: with the burner firing, close the manual gas shut off valve (detail "2" Figure 5-10). Gas valve should close and burner should stop firing. The boiler will try for ignition three times, then should lock out with a "Loc 1" error shown on the display. Open the manual gas shut-off valve, and verify your gas meter. Gas flow must be zero.





**CAUTION !!!** If gas flow occurs, close the manual gas shutoff valve and troubleshoot the system to determine why there is gas flow when the gas valve should be deenergized. Do not operate the boiler until the problem is resolved or a fire or explosion causing property damage, personal injury or loss of life may occur!

3. Press the "Reset" key to return to normal operation.

### 8.1.7 - Check wiring and connections

Inspect all heater wiring, making sure wires are in good condition and securely attached.

### 8.2 - Casing removal

Proceed as follows to remove the casing (refer to figure 8-2):

- 1.- pull the lower cover "A" towards the front for approx. 10mm
- 2.- push the lower cover "A" downwards;
- 3.- loosen the screws "H";
- 4.- pull the lower part of the front-piece "B" towards the front and then slide it out upwards until it is released from the guides "C";

To access the command and control board:

- 1.- turn the command board "D" towards the front;
- 2.- open the commands board "D" by operating on closure "G";

To access the electric connections board:

- 1.- turn the command board "D" towards the front;
- 2.- slide lid "E" out by operating on the "F" closing flaps;

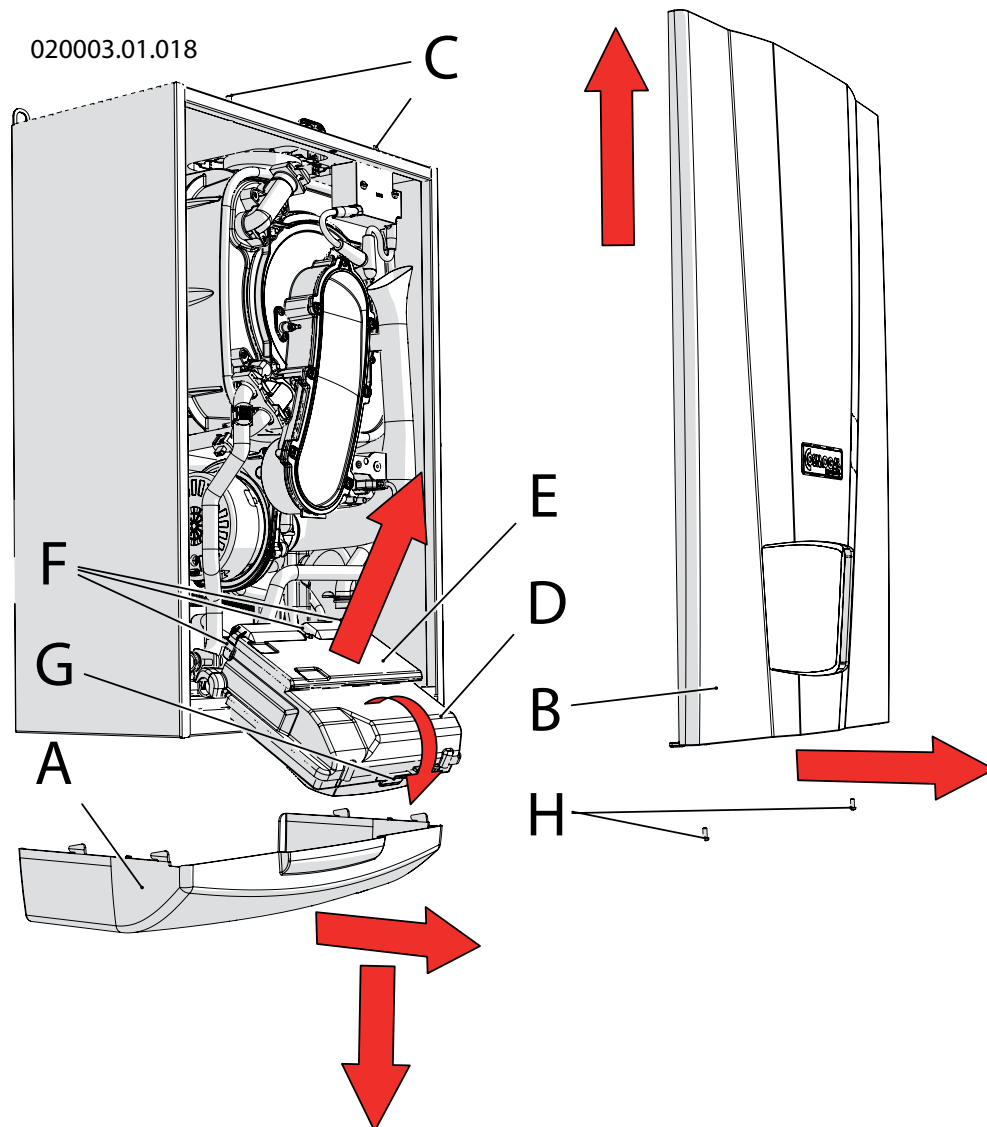


Figure 8-2 - removing the casing and opening of command board

### 8.3 - Burner and fan removal

Proceed as follows to remove the burner fan unit (refer to figure 8-3 when not differently specified):

- 1.- access the internal components following section 8.2;
- 2.- remove the air manifold (detail "C" in figure 6-3) rotating it towards the outside of the appliance and then pulling it towards the right (see figure 6-3);
- 3.- unscrew nut "C" from the valve "D";
- 4.- disconnect the cables "B" and the detection cable from the ignition and detection electrodes (details "15" and "35" of figures 3-1, 3-2, 3-3 and 3-4);
- 5.- unscrew the four nuts "E";
- 6.- extract the group "F" as per figure;

#### 8.3.1 - Thermal insulations

Thermal insulations must be checked every year and replaced if they are cracked or damaged. See Figures 8-3 where the thermal insulations (items "G" and "H") are showed assembled in the burner and in the heat exchanger.

**Once verified the condition of thermal insulation (see Figure 8-3), if necessary, replace with spare parts kit, following the instructions supplied with it. With the thermal insulation must be replaced the burner gasket "L" and the two gaskets of the electrodes.**

### 8.4 - Gas burner and heat exchanger outer surface cleaning procedure

To correctly clean the burner and the heat exchanger (exhaust flue side), proceed as follows (refer to figure 8-3 when not differently specified):

- 1.- access the internal components following section 8.2;
- 2.- remove the burner unit following section 8.3;
- 3.- use a suction device to remove the unburned residues present inside the combustion chamber;
- 4.- pass a cylindrical brush with plastic bristles inside the combustion chamber
- 5.- use the same suction device on the surfaces of the burner and around the electrodes;
- 6.- re-mount the components in reverse order;
- 7.- open the gas isolation valve;
- 8.- restore the electric power supply.
- 9.- check that there are no gas leaks on all joints;



**CAUTION!!! Perform the leak test using a soap solution. The use of flames is prohibited.**



**CAUTION!!! Every time you clean the burner and the heat exchanger verify the good condition of thermal insulation "G" and "H" (following section 8.3.1).**

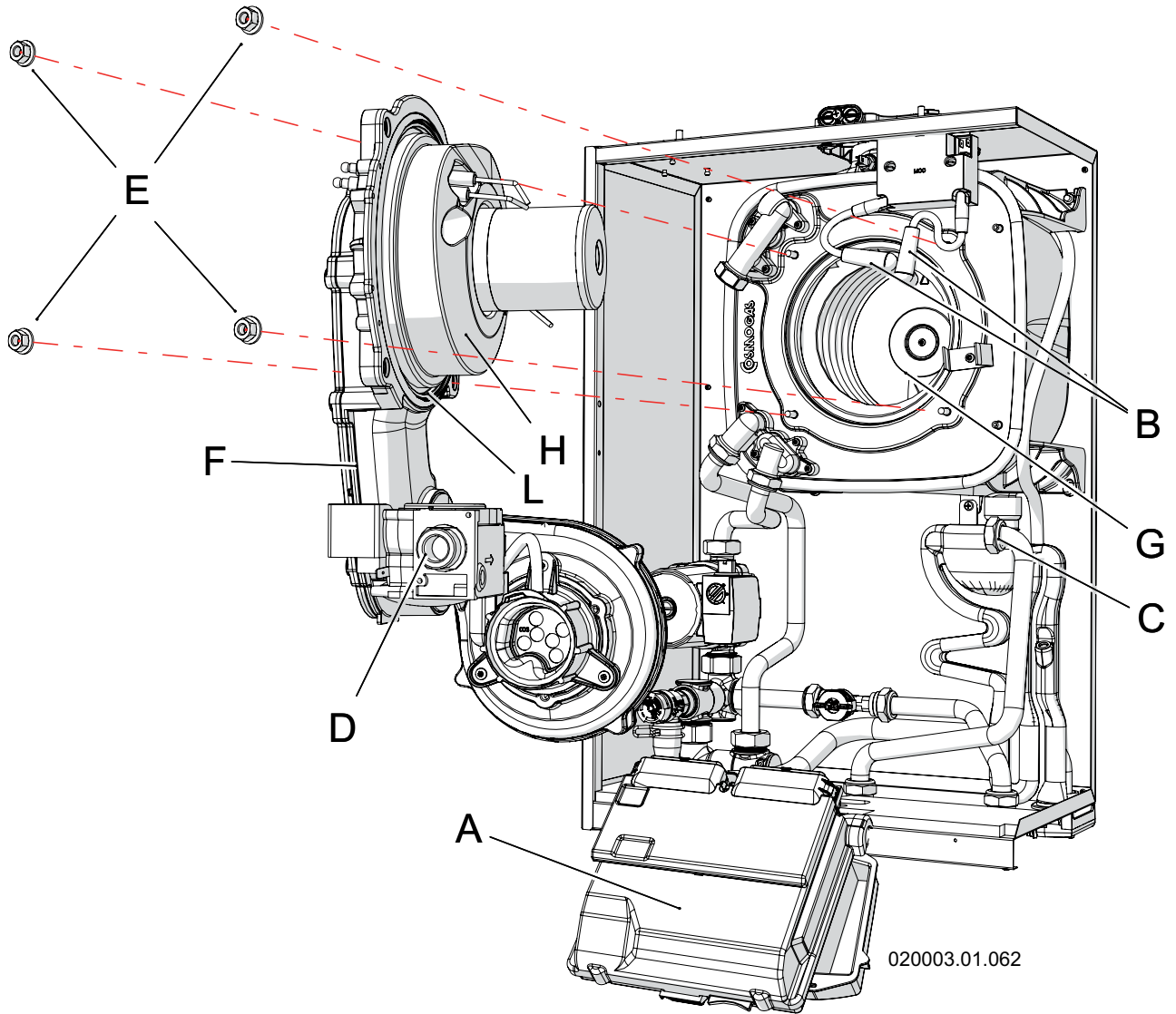


Figure 8-3 - Removing the burner fan unit

**GASKET**

**HEAT EXCHANGER DOOR**

020009.01.032

**CAUTION!!!** If gasket is damaged DO NOT reuse, the heat exchanger door must be replaced.

**NOTICE!** Gasket is intended for sealing combustion. If damaged DO NOT reuse, the heat exchanger door must be replaced. Consult factory for replacement heat exchanger door.

### 8.5 - Condensate siphon cleaning procedure

For correct cleaning of the collection siphon and the conveying of the condensate produced by combustion, operate as follows (refer to the figures 8-4, 8-5 and 8-6):

- 1.- with the appliance on, open a domestic hot water tap or taps fully to force the burner to its maximum power and the level of the liquid present inside the siphon tank "D" lowers (see figure 8-5);
- 2.- switch off the appliance and disconnect the electrical supply;
- 3.- access the internal components following section 8.2;
- 4 - remove the burner fan unit following section 8.3;
- 5 - cover the electric box with a cloth to protect it from any residues of water inside the siphon to be removed.
- 6.- slide the support "B" outwards from the holding support;
- 7.- slide the tank "C" downwards, paying attention to the fact that it is full of condensate water and this could escape;
- 8.- extract the siphon outwards (see figure 8-5) paying attention to disconnect the collection pipes of the water coming from the upper part of the appliance and from the air vent valve.
- 9.- clean the decanting tank "D";
- 10.- re-mount everything in reverse order, paying attention to the gasket "E", which is put back in the relevant seat and that terminal "G" is inserted correctly into seat "H";
- 11.- restore the level of liquid inside the siphon following the procedure in section 6.1.2.

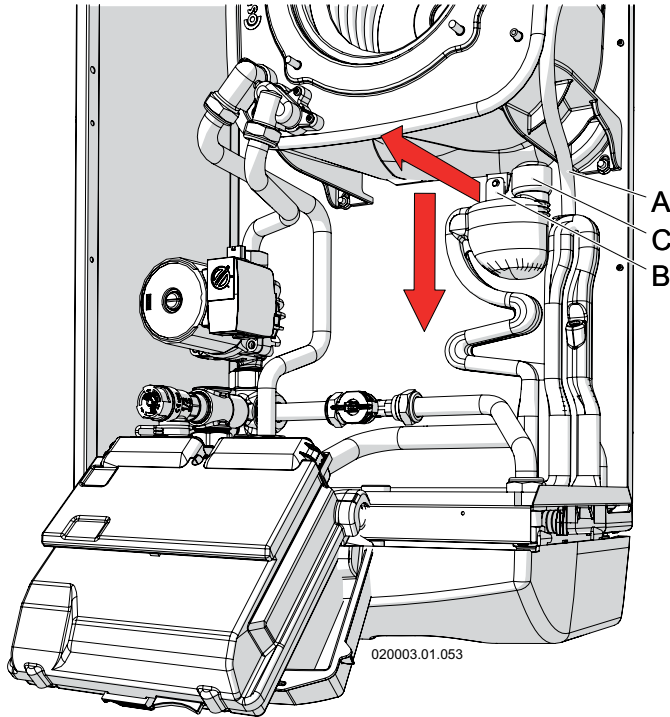


Figure 8-4 - Removal of the condensate collection siphon

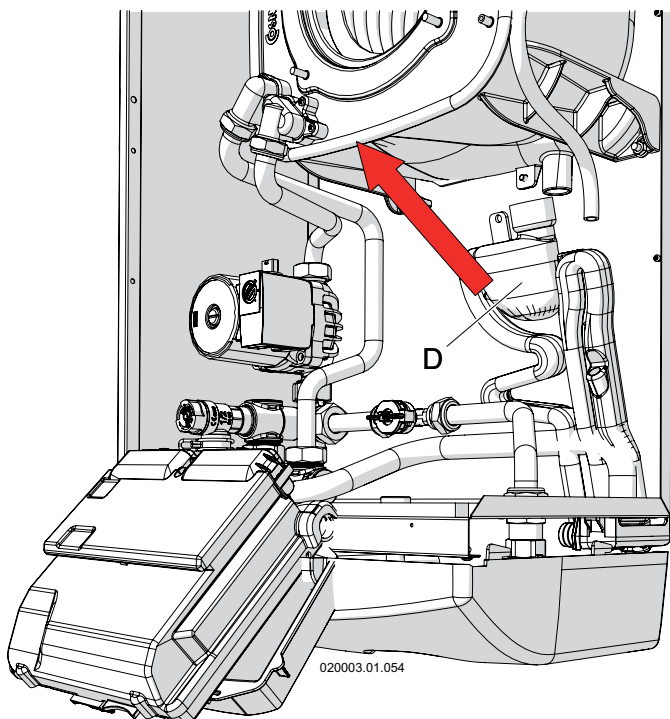


Figure 8-5 - Removing condensate collection siphon

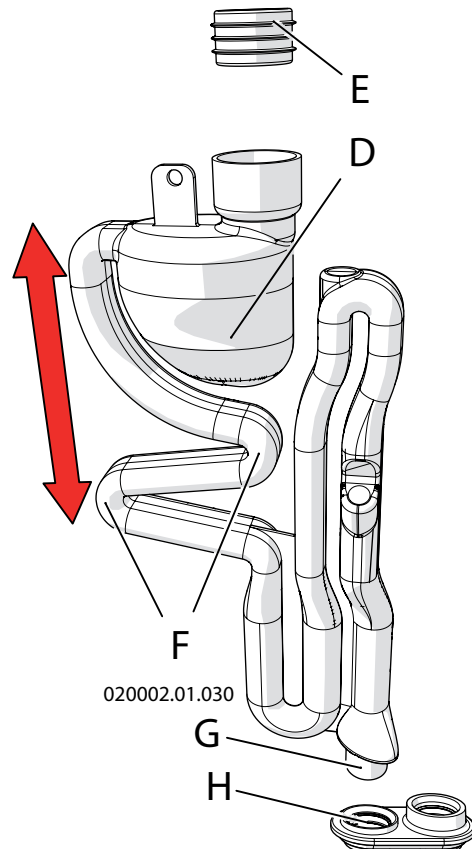


Figure 8-6 - Condensate collection siphon

### 8.6 - Ignition and flame ionising electrode position

For good working order of the appliance, it is indispensable that the electrodes are positioned correctly (refer to figure 8-7):

- the distance between the ignition electrodes "A" and "B", must be between 2,0 and 2,5 mm;
- the distance between the ignition electrodes from the burner surface must be between 5 and 5,5 mm;
- the distance of the ionisation electrode "C" from the surface of the burner must be between 5,5 and 6,5 mm.

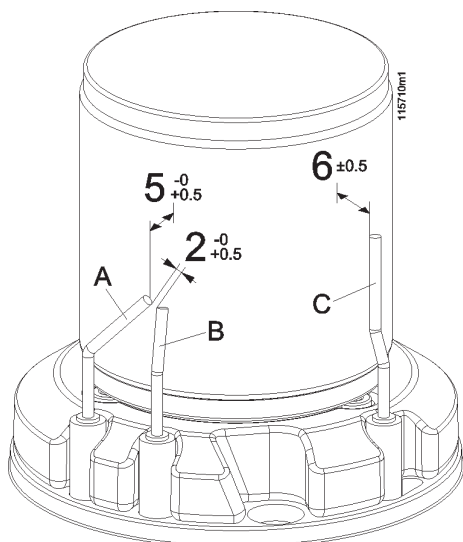


Figure 8-7 - positioning the electrodes on the burner

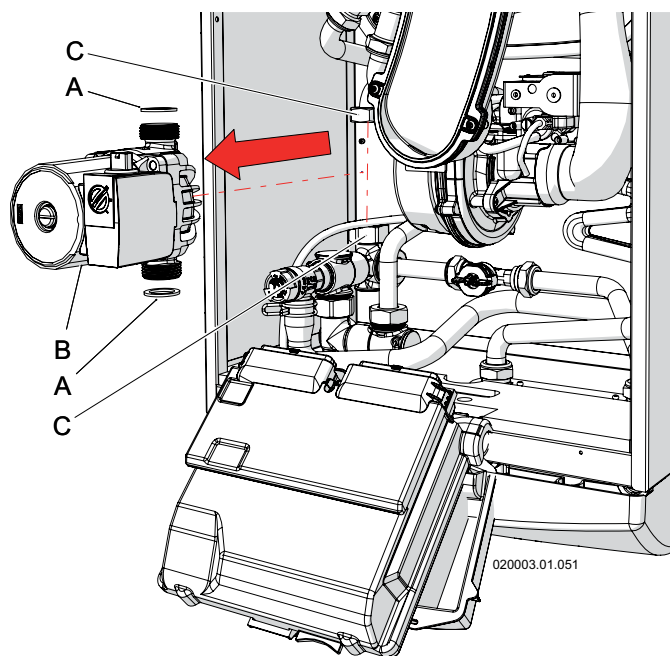


Figure 8-8 - Replacing the pump motor

### 8.7 - Circulation pump replacement procedure

Operate as follows if the pump must be replaced (refer to figure 8-8):

- 1.- empty the domestic hot water circuit, following the procedure in section 8.10;
- 2.- disconnect the electric power supply upstream from the appliance;
- 3.- access the components inside the appliance, following section 8.2;
- 4.- disconnect the electric cables from the pump body.
- 5.- loosen the nuts "C";
- 6.- extract the pump "B" outwards and replace it.

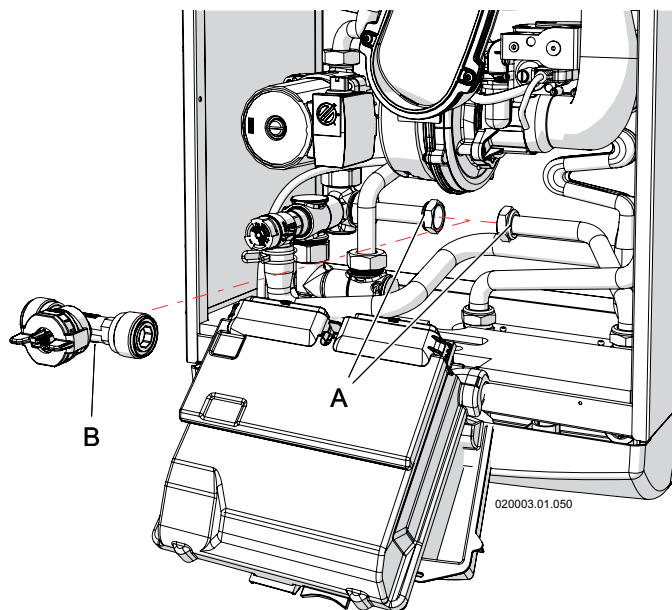


Figure 8-9 - Removing the flow meter

### 8.8 - Domestic water flow meter replacement procedure

Proceed as follows, making reference to figure 8-9:

- 1.- empty the domestic hot water circuit, following the procedure in section 8.10;
- 2.- disconnect the electric power supply upstream from the appliance;
- 3.- access the components inside the appliance, following section 8.2;
- 4.- disconnect the cables from the flow meter (detail "B" in figure 8-9);
- 5.- unscrew the tightening nuts "A", paying attention that the residual water from the pipes does not reach the control board;
- 6.- slide the flow meter "B" upwards and replace it.

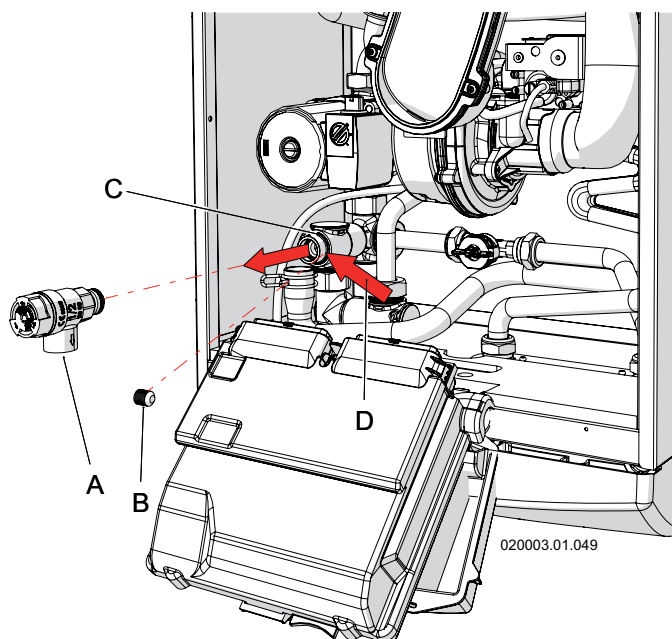


Figure 8-10 - Removing the safety valve

### 8.9 - Safety valve replacement procedure

The safety valve (detail "A" in figure 8-10) protects the appliance from over pressures. If it has to be replaced, proceed as follows (refer to figure 8-10):

- 1.- empty the domestic hot water circuit, following the procedure in section 8.10;
- 2.- access the components inside the appliance, following section 8.2;
- 3.- disconnect the drain pipe from the valve to be replaced "A";
- 4.- unscrew the lower fixing disk "B" of valve "A";
- 5.- extract the safety valve "A" upwards and replace it.



### 8.10 - Procedure for draining the water heater

To empty the appliance from the domestic hot water side, proceed as follows:

- 1.- close the main cold water supply isolation valve;
- 2.- open all hot and cold water taps;
- 3.- make sure that at least one of these is at a height below the level of the appliance.

### 8.11 - Fan test mode procedure

Switch-on of the fan only can be generated, accessing the parameter **20 10** situated inside the "Installer menu" (see section 7.8) and set it on **FAN**. To go back to normal operating conditions, set parameter **20 10** again to **OFF**.

### 8.12 - Gas burner minimum and maximum performance test mode procedure

Appliance operation can be forced to its own minimum, maximum, adjusted or ignition power. Proceed as follows:

- 1.- access parameter **20 10** found in the "installer menu" (see section 7.8);
- 2.- set the parameter **20 10** at the following value:
  - a) **LOW** to force the appliance to minimum power;
  - b) **IGN** to force the appliance to ignition power;
  - a) **HIGH** to force the appliance to maximum power;
  - a) **RES** to force the appliance to maximum power.
- 4.- to end forcing, take the parameter **20 10** to the **OFF** value and press the RESET key.



### 8.13 - Checking the ionisation current

In any operating status, also during verifications of minimum and maximum power stated in section 8.12, the ionisation current value can be consulted on parameter **1008** present in the "User menu" (section 7.7). This value must be between 1,5 and 3 uA (microampere) at minimum power and between 5 and 8 uA at maximum power.

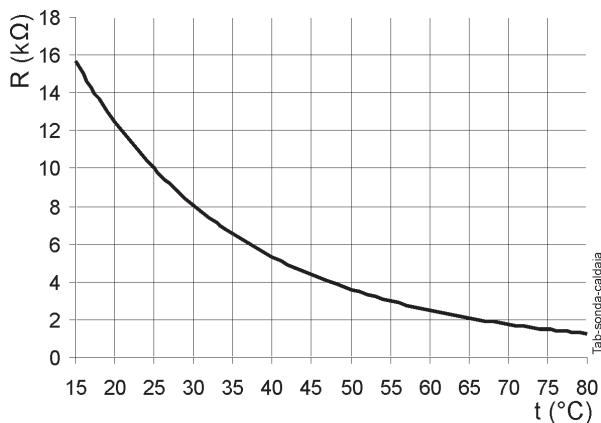


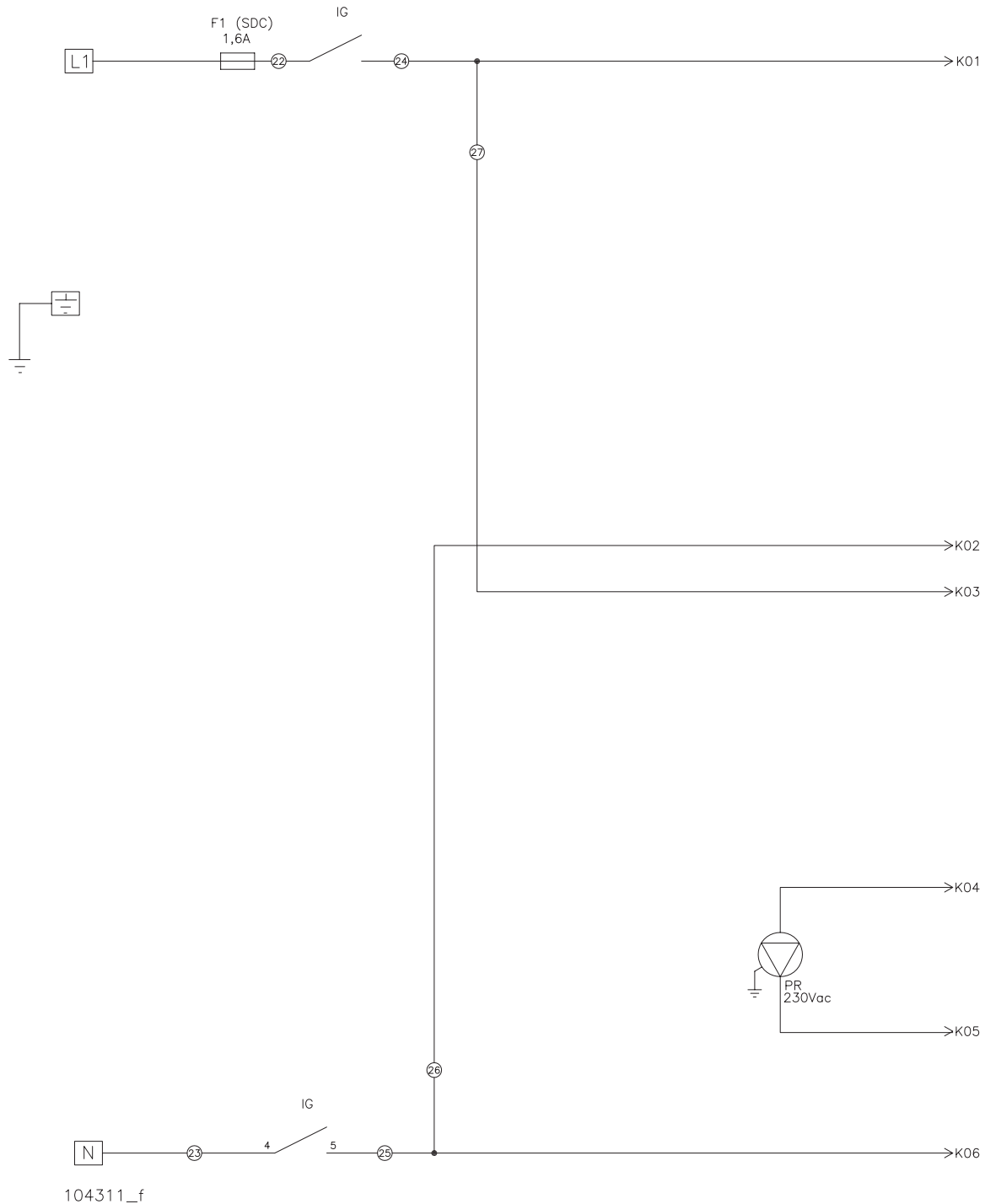
Figure 8-11 - Water sensors curve

### 8.14 - Water temperature measurement sensor testing procedures

The temperature sensors are positioned on the appliances' exchanger body. The electric resistance existing between the two contacts of the sensor, must correspond with that stated in figure 8-11.


The temperature sensors are: **1001**, **1002**, **1003**, **1005**, **1006**, **1007** and **1014**, the positioning of which can be verified in figures 3-1, 3-2, 3-3 and 3-4.

8.15 - Operational wiring diagram



→ K1      K1 →

104111m0\_esempio



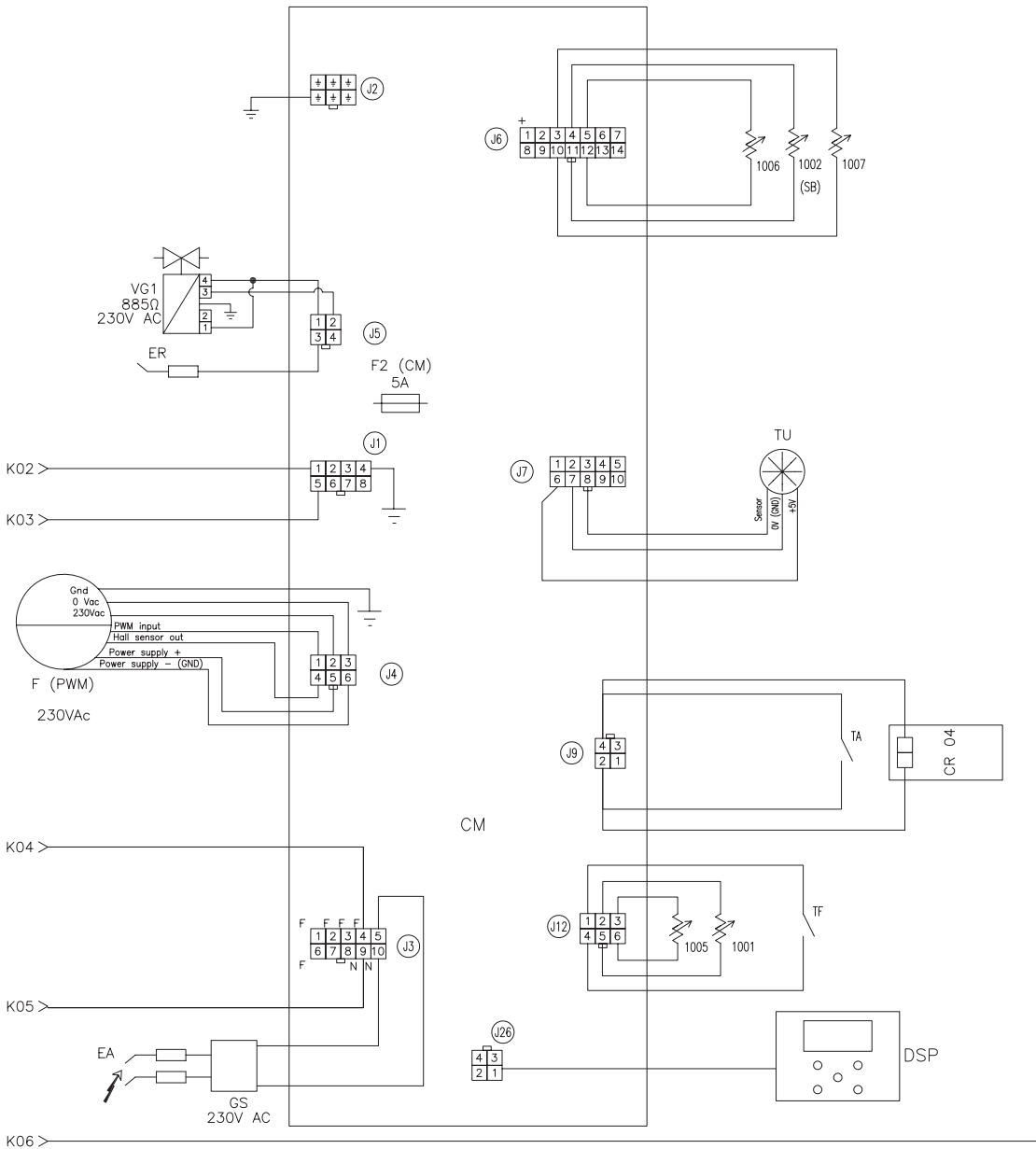
**ATTENTION !!! To consult the wiring diagram correctly, references K are given followed by a number (see example above) to identify the correct follow-on of the cables in the next page.**

- 1001 - D.H.W. outlet temperature sensor 1
- 1002 - D.H.W. outlet temperature sensor
- 1002 (SB) - Storage tank sensor (on request)
- 1005 - D.H.W. outlet temperature safety sensor 2
- 1006 - Exhaust flue sensor 1
- 1007 - Cold water inlet sensor
- 1014 - Exhaust flue safety sensor 2
- CM - Appliance control unit and flame control
- CR - Remote control CR01
- CR04 - Remote control CR04
- DSP - Display
- EA - Ignition electrode

Figure 8-12 - Operational wiring diagram

# 8 - MAINTENANCE

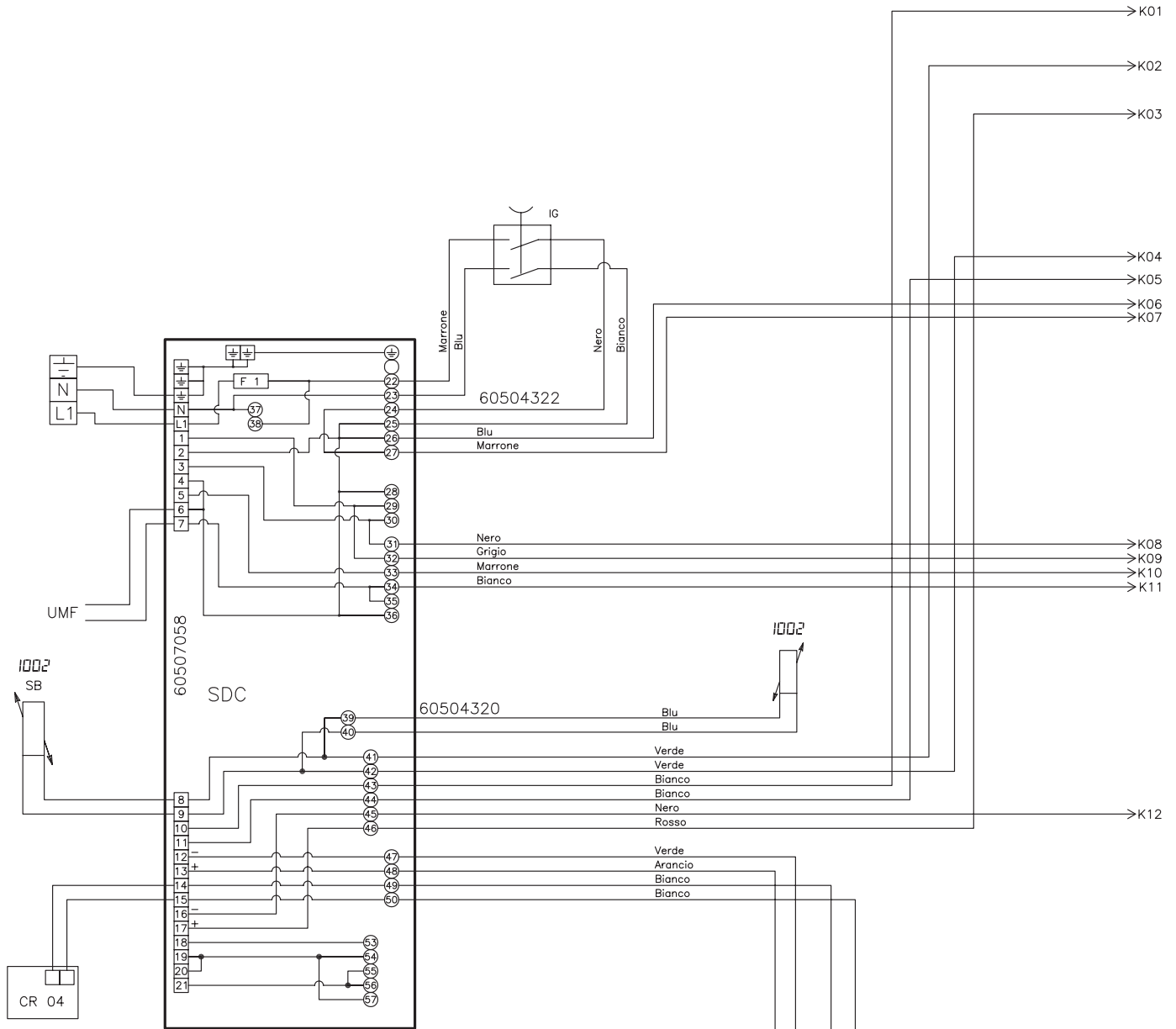
K01 >



- ER - Detection electrode
- F (PWM) - PWM fan
- F (BCU) - 5A fuse
- F1 (SDC) - 1.6A power supply fuse
- PB - Storage tank load aux. pump (on request)
- PR - Recirculation Pump
- GS - Spark generator
- IG - Master switch
- J1 - 8 pin Molex connector
- J12- 6 pin Molex connector
- J2 - 6 pin Molex connector
- J26- 4 pin Molex connector
- J3 - 10 pin Molex connector

- J4 - 6 pin Stelvio connector
- J5 - 4 pin Molex connector
- J6 - 14 pin Molex connector
- J7- 10 pin Molex connector
- J9- 4 pin Molex connector
- PB - Storage tank pump (on request)
- SDC- Connection board
- TF- High limit flue gas temperature fuse
- TU - Domestic hot water flow meter
- VG1- Gas Valve

8.16 - Multi-wire wiring diagram

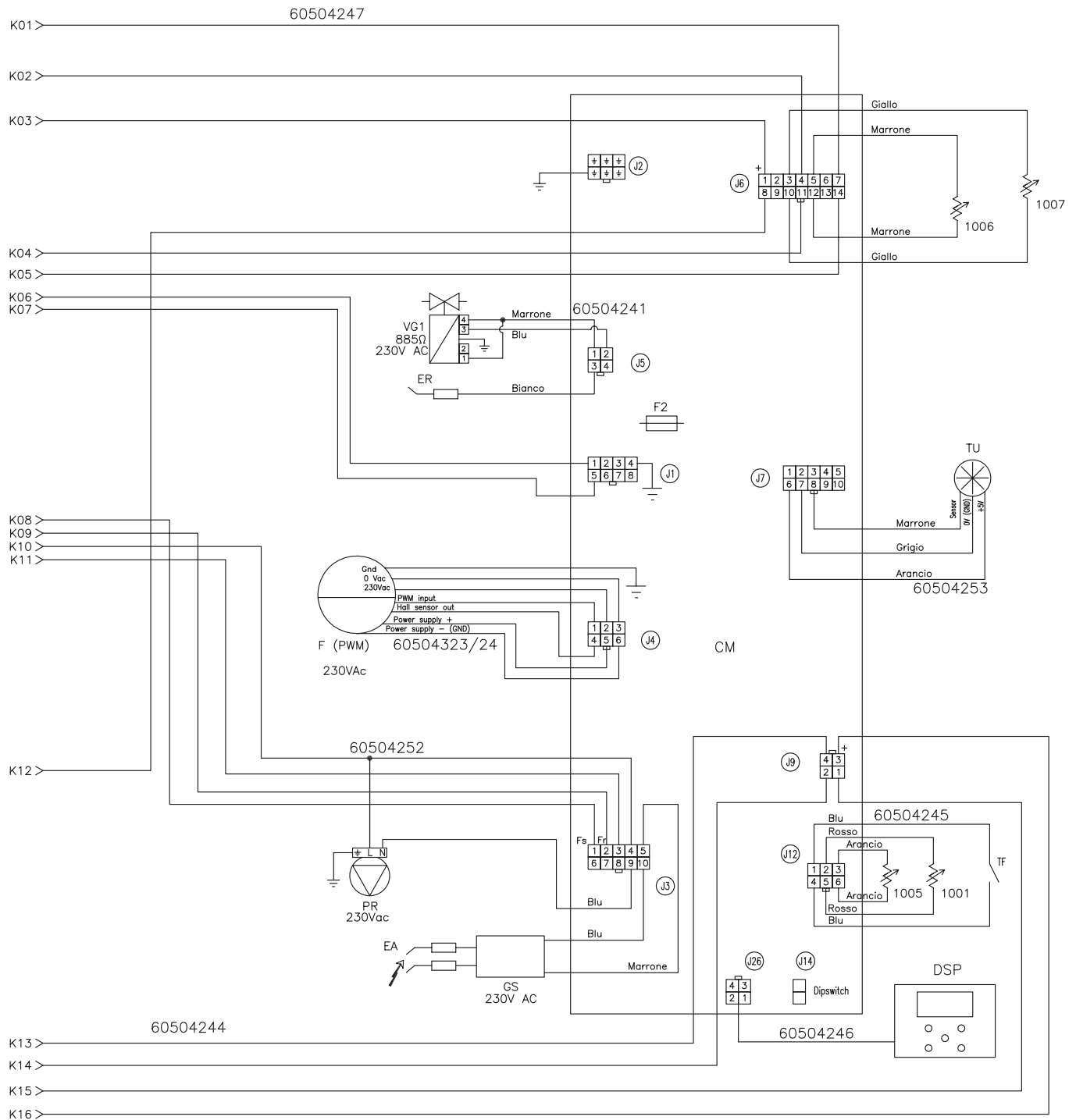


COLOR OF DIAGRAM CABLE  
 ARANCIO = ORANGE  
 BIANCO = WHITE  
 BLU = BLUE  
 GIALLO = YELLOW  
 GIALLO/VERDE = YELLOW/GREEN  
 GRIGIO = GREY  
 MARRONE = BROWN  
 NERO = BLACK  
 ROSSO = RED  
 VERDE = GREEN

104311\_m

Key - see key figure 8-12

Figure 8-13 - Multi-wire wiring diagram












## 9 - TECHNICAL DATA

TECHNICAL DATA		UM	AGUADENS 16	AGUADENS 22	AGUADENS 37
Type (Type of exhaust flue/combustion air intake)			B23;C13;C33;C43;C53;C63;C83;C93		
Category			I12H3P	I12H3P	I12H3P
CE type certificate (PIN)			0476CQ1097	0476CQ1097	0476CQ1097
Max. heat input NET (GROS)		kW	25,5 (28,3)	32,0 (35,5)	57,8 (64,2)
Min. heat input NET (GROS)		kW	3,2 (3,6)	6,0 (6,7)	12,0 (13,3)
Max. useful heat output		kW	27,0	33,5	60,9
Efficiency at max heat output NET (GROS)		%	106 (96)	105 (95)	107 (96)
Min. heat output		kW	3,30	6,14	12,85
Efficiency at min heat output NET (GROS)		%	103 (93)	102 (92)	107 (96)
Gas flow rate	G20	m³/h	2,70	3,38	6,11
	G31	Kg/h	1,98	2,48	4,49
Gas supply pressure	G20	mbar	20	20	20
	G31	mbar	37	37	37
Gas supply minimum pressure	G20	mbar	15	15	15
	G31	mbar	15	15	15
Gas supply maximum pressure	G20	mbar	45	45	45
	G31	mbar	45	45	45
D.H.W. adjustment range		°C	40-75	40-75	40-75
D.H.W. flow rate ( $\Delta t$ 30°C)		l/min	13,0	16,1	29,5
Domestic circuit maximum pressure		bar	10	10	10
Domestic circuit minimum pressure		bar	1	1	1
Minimum water flow		l/min	2,5	2,5	2,5
Rated power supply voltage		V	230	230	230
Rated power supply frequency		Hz	50	50	50
Absorbed electric power		W	169	162	235
Electric protection degree			IPX4D	IPX4D	IPX4D
Exhaust flue and air intake pipe diameter (split)		mm	80	80	80
Exhaust flue pipe max. length (split) (80)		m	20	12,5	5
Air intake pipe max. length (split) (80)		m	20	12,5	5
Exhaust flue pipe diameter (coaxial)		mm	60/100	60/100	80/125
Exhaust flue pipe max. length (coaxial)		m	10	10	10
Equivalent length of a bend		m	Curva a 45° = 0.5m, curva a 90° = 1m		
Weighted CO (0% O2 with natural gas) (EN26:2015) GROS		ppm	11	19	10
Weighted NOx (0% O2 with natural gas) (EN26:2015) GROS	G20	mg/kWh	20	29	16
Weighted NOx (0% O2 with natural gas) (EN26:2015) GROS	G31	mg/kWh	24	34	20
CO2 (%) at minimum/maximum power	G20	%	8,5/9,0	8,5/9,0	8,3/8,7
	G31	%	10/10,5	10/10,5	10,8/10,1
Exhaust flue gas maximum temperature at appliance outlet		°C	90	90	90
Mass flow rate of exhaust flue gases		kg/h	41,9	52,5	97,8
Head available at exhaust flue outlet		Pa	60	60	60
Exhaust flue gas maximum temperature for overheating		°C	90	90	90
Max. negative pressure in exhaust flue system		Pa	60	60	60
Condensate maximum flow rate		l/h	3,2	4,0	7,2
Condensate average acidity		PH	4	4	4
Operating environment temperature		°C	0 ; +50	0 ; +50	0 ; +50
Weight of the appliance		kg	36	36	48



# 10 - COMMAND MENU DIAGRAM

Key for figure 10-1

Symbol	Description
	Press and release the RESET key
	Hold the reset key down for a time in seconds, indicated by the number (2)
	Hold the reset key down for a time in seconds, indicated by the number (5)
	Hold down the RESET and  key simultaneously for a time in seconds, indicated by the number
	Press and release the  key
	Press and release the  key

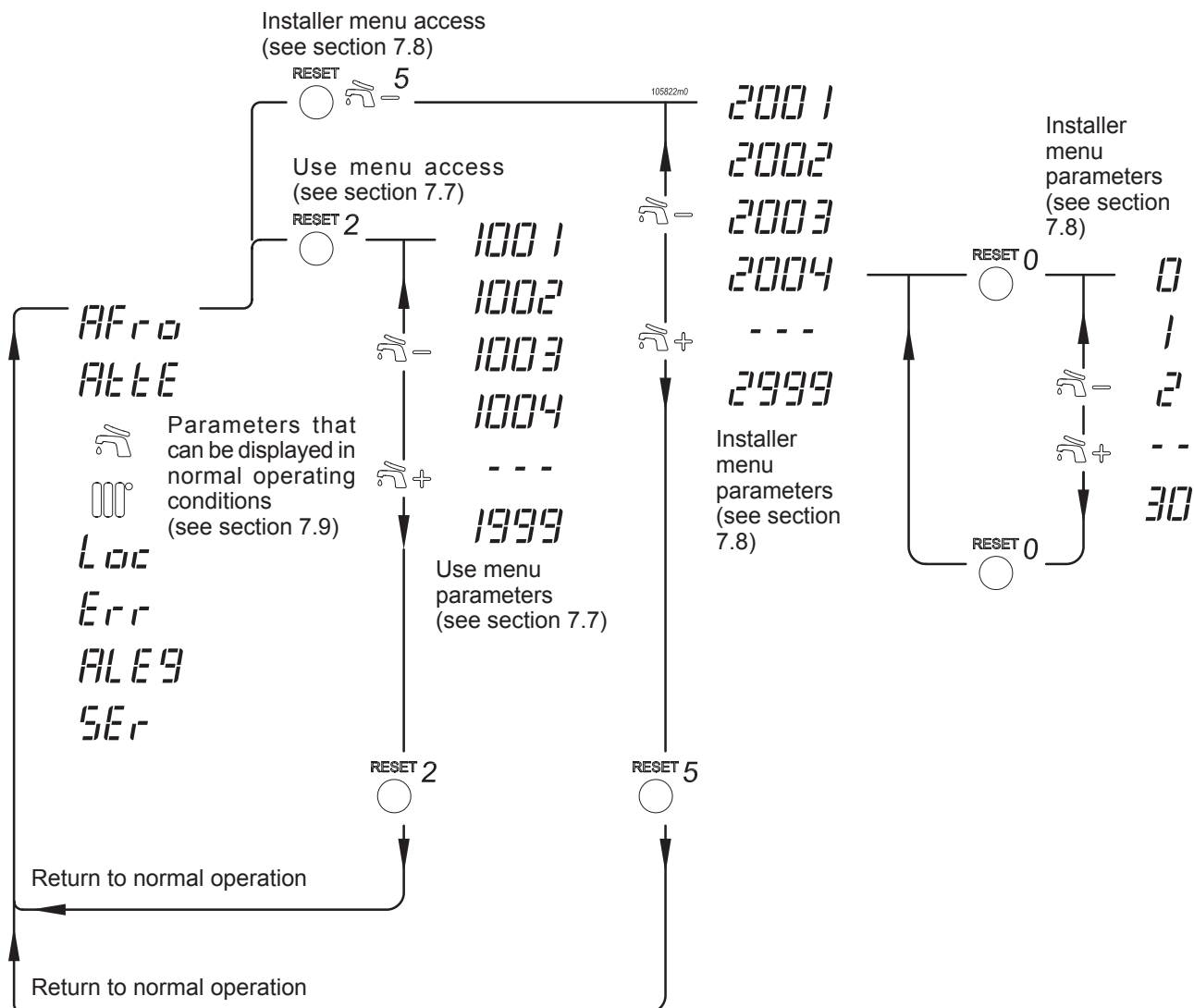


Figure 10-1 - Command menu diagram  
COSMOGAS

## 11 - ENGINEERS TEST MODE



### ATTENTION !!!

The modification of these parameters could cause the appliance, and therefore the plant, to malfunction. For this reason only a technician that has the awareness and in-depth knowledge of the appliances can modify them.

To access this menu, move the microswitch as stated in figure 6-6 detail "B".

Parameter	Parameter Description	M.U.	Setting range	Factory value	Customised value
3001	Cascade adress (N/A)	(N/A)	(N/A)	0	(N/A)
3002	Selection type		From 50 to 55	See figure 6-8	
3012	Domestic hot water operating mode	/	0 = <b>DO NOT USE</b> ; 1 = Storage tank with temperature sensor; 2 = Storage tank with thermostat; 3 = <b>DO NOT USE</b> ; 4 = <b>DO NOT USE</b> ; 5 = <b>DO NOT USE</b> ; 6 = <b>DO NOT USE</b> ; 7 = <b>DO NOT USE</b> ; 8 = Instantaneous water heater;	8	
3013	Plant fill automatic valve (N/A)	(N/A)	(N/A)	0	(N/A)
3014	Instantaneous domestic hot water pre-heat	/	OFF = No pre-heat ON = With pre-heat	OFF	(N/A)
3015	Maximum central heating temperature (N/A)	(N/A)	(N/A)	80	(N/A)
3016	Minimum central heating temperature (N/A)	(N/A)	(N/A)	30	(N/A)
3017	Pre-heat mode (N/A)	(N/A)	(N/A)	0	(N/A)
3018	Minimum DHW temperature	°C	From 30 to 75	40	
3019	Maximum DHW temperature	°C	From 30 to 75	60	
3020	Domestic hot water flow rate sensor	/	0 = B; 1 = DN 8; (model 16) 2 = DN 10; 3 = DN 15; (models 22 and 37) 4 = DN 20; 5 = DN 25;	1 (16) 3 (22) 3 (37)	
3021	2nd Exhaust flue sensor (1014) (N/A)	(N/A)	(N/A)	0	(N/A)
3022	Central heating minimum pressure (N/A)	(N/A)	(N/A)	0,8	(N/A)
3023	Water pressure sensor	/	0 = Disabled; 1 = Enabled;	0 (16) 0 (22) 0 (37)	
3033	Modulating pump (N/A)	(N/A)	(N/A)	0	(N/A)
3034	Modulating pump delta T target (N/A)	(N/A)	(N/A)	15	(N/A)
3040	Antilegionella for water heater	/	ON = Antilegionella enable OFF = Antilegionella disabled	ON	
3041	Tank supply temperature increase	°C	From 0 to 30	0	
3042	Minimal water flow	l/min	From 0 to 25,5	2,5	

N/A = Not applicable

The undersigned **COSMOGAS S.r.L.**, with Registered Office in via L. Da Vincin° 16 - 47014 Meldola (FC) ITALY,

### DECLARES

under its own responsibility that the product:

WARRANTY N°
GAS BOILER MODEL
DATE OF MANUFACTURE

subject of this declaration, is compliant with the model described in the **CE** type Test Certificate, issued by the notified body Kiwa Cermet Italia S.p.A., whose references are shown in the table in the TECHNICAL FEATURES section under “CE-type certificate (PIN)” and fulfils the requirements of the following Directives: Gas Appliances, **(2009/142/EC)**, Performance, **(92/42/EEC** modified by **EU Reg. 813/2013)**, Low Voltage, **(2014/35/EU)**, Electromagnetic Compatibility, **(2014/30/EU)**.

Product surveillance is done by the notified body according to form “C”.

(The warranty number is the same as the serial number)

This declaration is issued as established by the aforementioned Directives.

Meldola (CFC) ITALY, (Date of manufacture).



---

Alessandrini Arturo  
General Manager







COSMOGAS s.r.l.  
Via L. da Vinci 16 - 47014  
MELDOLA (FC) ITALY  
[info@cosmogas.com](mailto:info@cosmogas.com)  
[www.cosmogas.com](http://www.cosmogas.com)