

INSTALLATION, USE AND MAINTENANCE MANUAL

**GAS-FIRED WALL-MOUNTED
CONDENSING WATER HEATER**

AGUADENS

CONTENTS

1 - GENERAL SAFETY WARNINGS.....	4
1.1 - National laws and regulations	5
2 - GENERAL INFORMATION	6
2.1 - Presentation	6
2.2 - Overview of models.....	6
2.3 - Accessories	6
2.4 - Manufacturer	7
2.5 - Meaning of symbols used	7
2.6 - Maintenance.....	7
2.7 - Disposal	7
3 - MAIN COMPONENTS.....	8
4 - OPERATION	12
4.1 - Operation and intended use of the appliance	13
4.2 - Examples of installation	14
5 - INSTALLATION	16
5.1 - Opening the package	16
5.2 - Dimensions and minimum distances to be observed.....	16
5.3 - Choosing where to install the appliance.....	16
5.4 - Unit assembly.....	17
5.5 - Domestic hot and cold water	17
5.6 - Gas.....	18
5.7 - Condensate drain.....	18
5.8 - Safety valve.....	18
5.9 - Hydraulic and gas connections, and mounting of the lower cover	19
5.10 - Polyphosphate softener (on request)	19
5.11 - Electrical connections: details	20
5.11.1 - Connecting power supply cable	21
5.11.2 - CR04 remote time control (on request).....	21
5.11.3 - Alarm output.....	21
5.12 - Recirculation with external pump	22
5.13 - Recirculation with internal pump	22
5.14 - Connection of hot water heater to storage tank	23
5.14.1 - Anti-legionella.....	23
5.15 - Cascade appliances connection	24
5.15.1.- Cascade appliances connection	24
5.15.2.- Cascade appliances connection with storage tank.....	26
5.16 - Burned gas exhaust and combustion agent air intake pipe	28
5.16.1 - Type of intake/exhaust B23 and B23P	29
5.16.2 - "Split 80/80PP" system (polypropylene) (type C43; C53; C83; C93) AGUADENS 16 and 22	30
5.16.3 - "Split 80/80PP" system (polypropylene) (type C43; C53; C83; C93) AGUADENS 37	31
5.16.4 - "Split 80/80PP" system (type C43; C53; C83; C93): accessories available.....	32
5.16.5 - "Split 80/80PP" system (type C43; C53; C83; C93): installation examples	33
5.16.6 - "60/100PP vertical coaxial" system (polypropylene) (type C13; C33) AGUADENS 16 and 22.....	34
5.16.7 - "60/100PP horizontal coaxial" system (polypropylene) (type C13; C33) AGUADENS 16 and 22	35
5.16.8 - "60/100PP coaxial" system: accessories available	36
5.16.9 - "60/100PP coaxial" system: installation examples.....	37
5.16.10 - "80/125PP vertical coaxial" system (polypropylene) (type C13; C33) AGUADENS 37.....	38
5.16.11 - "80/125PP coaxial" system: accessories available	39
5.16.12 - "80/125PP coaxial" system: installation examples.....	40
5.16.13 - "80PP single" system (polypropylene) (type B23 or B23P) AGUADENS 16 and 22.....	41
5.16.14 - "80PP single" system: accessories available	41
6 - START-UP	42
6.1 - Start-up	42
6.1.1 - Instructions to the user.....	42
6.1.2 - Filling the condensate drain siphon	42
6.2 - General recommendations regarding the gas supply	42
6.3 - Type of gas for which the appliance is set.	43
6.4 - Conversion of the appliance from one type of gas to another.....	43
6.5 - Ignition.....	45
6.6 - Controlling the supply gas pressure and any adjustments.....	45
6.7 - Controlling the level of CO2 and any adjustments	46
6.8 - Automatic learning and calibration of minimum and maximum power	47

CONTENTS

6.9 - Adjusting the domestic hot water flow rate.....	47
6.10 - Checking the maximum heat input.....	47
7 - USE.....	48
7.1 - General information.....	48
7.2 - Ignition procedure.....	48
7.3 - Adjusting the hot water temperature.....	49
7.4 - Time settings for the various functions.....	49
7.5 - Anti-freeze protection.....	49
7.6 - "User profile".....	50
7.7 - "Installer profile".....	52
7.7.1 - Parameters for cascade systems.....	56
7.8 - Diagnostics.....	57
7.8.1 - Diagnostics: lockouts "Loc".....	57
Check that the water flow (1062) is higher than the value of parameter 2140.....	62
Check the correct connection to the display and to the water flow sensor.....	62
7.8.2 - Diagnostics: errors "Err".....	60
7.8.3 - Diagnostics: alarms "AttE".....	63
7.9 - Turning the appliance on and off.....	63
8 - MAINTENANCE.....	64
8.1 - General recommendations.....	64
8.2 - Maintenance protocol.....	65
8.2.1 - Checking there are no water leaks.....	65
8.2.2 - Checking the gas pressure and any leaks.....	65
8.2.3 - Checking the condition of the safety valve.....	65
8.2.4 - Checking the condition of the safety and control devices.....	66
8.2.5 - Checking the condition of the electrical system.....	66
8.2.6 - Checking the operation of the main switch.....	66
8.2.7 - Checking the correspondence of the adjusted temperatures in the domestic hot water system.....	66
8.2.8 - Checking if the device is triggered in the event of gas failure.....	66
8.2.9 - Checking the condition of the air intake and flue exhaust ducts.....	66
8.2.10 - Checking the ignition and detection electrodes.....	66
8.2.11 - Checking the condition of the air vent valves.....	66
8.3 - Removing the casing and accessing the internal components.....	67
8.4 - Dismantling the burner fan assembly.....	68
8.5 - Cleaning the burner and the primary heat exchanger (flue gas side).....	68
8.6 - Correctly positioning the ignition and detection electrodes.....	69
8.7 - Dismantling the ignition and detection electrodes.....	69
8.8 - Dismantling and replacing the gas valve.....	70
8.9 - Cleaning the condensate conveyor siphon.....	71
8.10 - Replacing the pump.....	72
8.11 - Removing the domestic hot water flow meter.....	72
8.12 - Removing the safety valve.....	72
8.13 - Emptying the appliance on the domestic hot water side.....	73
8.14 - Minimum and maximum power.....	73
8.15 - Checking the ionisation current.....	73
8.16 - Water temperature measurement sensors.....	73
8.17 - Wiring diagram.....	74
9 - TECHNICAL DATA.....	76
10 - PRODUCT FICHE.....	78
11 - COMMAND MENU DIAGRAM.....	79
12 - NOTE.....	80
13 - UE DECLARATION OF COMPLIANCE.....	83

1 - GENERAL SAFETY WARNINGS

If you smell gas

- 1.- Close the gas cock;
- 2.- Ventilate the room;
- 3.- Do not switch on any electric device, including a telephone;
- 4.- From another room, immediately call a professionally qualified technician or the gas supply company. Call the Fire Service if the former are not available.

If you can smell combustion products

- 1.- Switch the appliance off;
- 2.- Ventilate the room;
- 3.- Call a professionally qualified technician.

Explosive or highly flammable products

Do not store or use explosive materials or highly flammable materials such as paper, solvents, paints, etc. in the room where the appliance is installed.

Installation, modifications

- ☞ The gas appliance must be installed, calibrated and modified by professionally qualified staff, in compliance with national and local regulations, as well as the instructions in this manual.
- ☞ Incorrect installation or poor maintenance can cause damage or injury to persons, animals or objects, for which the manufacturer cannot be deemed liable.
- ☞ The appliance exhaust must be connected to a burned gas evacuation pipe. Failure to comply with this regulation leads to serious risks for the safety of persons and animals.
- ☞ A domestic hot water temperature exceeding 51°C can cause permanent damage or injury to persons, animals and objects. In particular, protect children, the elderly and people with disabilities against any possible risks of scalds, by inserting devices that limit the usage temperature of the DHW to users.
- ☞ The parts conducting the flue gas must not be modified.
- ☞ Do not obstruct the ends of the intake/exhaust pipes.
- ☞ Do not leave parts of the packaging and any replaced parts within the reach of children.
- ☞ Seal the adjustment devices after every calibration.
- ☞ In agreement with the provisions for use, the user must keep the installation in good working order and guarantee reliable and safe operation of the appliance.
- ☞ We would also highlight the benefit of an annual scheduled maintenance contract with a professionally qualified technician.
- ☞ The user must have maintenance performed on the appliance by a professionally qualified technician in compliance with national and local regulations and this manual.
- ☞ Before performing any cleaning or maintenance operations, disconnect the appliance from the mains power supply and/or use the cut-off devices.
- ☞ After having performed any cleaning or maintenance operations, make sure that all internal parts of the appliance are dry before re-connecting the electric power supply.
- ☞ This appliance is not intended for use by persons (including children) with reduced physical, sensory and mental capabilities or a lack of experience or knowledge, unless they are supervised or have been instructed on use of the appliance by a person responsible for their safety.
- ☞ This manual is an integral and essential part of the product and must be retained carefully by the user for future

consultation. If the appliance needs to be transferred or if you should move and leave the unit to another user, always ensure that this manual remains with the new user and/or installer.

- ☞ Any options or kits added later must be original Cosmogas products.
- ☞ This storage tank must be used only for the purpose for which it was expressly intended: the production of hot water for domestic and sanitary uses for civil use.
- ☞ Any contractual and non-contractual liability on the part of the manufacturer is excluded for damage caused by installation errors or usage errors and, in all cases, following a failure to comply with the instructions given by the manufacturer or with applicable national and/or local laws.
- ☞ For safety reasons and to safeguard the environment, the packaging components must be disposed of in the relevant separate waste collection centres.

In case of breakdown

In the event of a fault and/or poor operation of the appliance, disconnect it and do not attempt to carry out any repairs. Contact a professionally qualified technician only. If components need to be replaced, these must be original spare parts. Failure to comply with the above may jeopardise the safety of the appliance.

Professionally qualified technicians.

A 'professionally qualified technician' means a person with specific technical skill in the sector of central heating system components and the production of domestic hot water for sanitary and civil uses, electric installations, and systems for the use of combustible gas. Such people must have the skills envisaged by the law.

Technical drawings

All the drawings shown in this manual relating to electrical, hydraulic or gas installation systems must be understood to be purely illustrative. All the safety devices, auxiliary devices as well as the diameters of the electrical, hydraulic and gas pipes, must always be checked by a professionally qualified technician, to make sure they satisfy the applicable laws and regulations.

1 - GENERAL SAFETY WARNINGS

1.1 - National laws and regulations

- M.D. n°37 dated 22/01/2008 (former Law n°46 dated 05/03/90)
- Law n°10 dated 09/01/91

- Presidential Decree n°412 dated 26/08/93
- Presidential Decree n°551 dated 21/12/99
- Legislative Decree n° 192 dated 19/08/05
- Legislative Decree n° 311 dated 29.12.06

- UNI 7129 Standard
- UNI 7131 Standard
- UNI 11071 Standard
- IEC 64-8 Standard

All the gas appliances must be installed by a competent and qualified person, in accordance with relevant clauses of applicable standards and recommendations. These include but may not be limited to the following:

- I.S. 813 Domestic gas installations.

- I.S. 820 Non-Domestic gas installations.

- IEE Wiring Regulations.

- BS 5546:2010 - Specification for installation and maintenance of gas-fired water-heating appliances of rated input not exceeding 70 kW net.

- BS 5440-2:2009 - Flueing and ventilation for gas appliances of rated input not exceeding 70 kW net (1st, 2nd and 3rd family gases) specification for the installation and maintenance of ventilation provision for gas appliances.

- BS 6644:2011 - Specification for the installation and maintenance of gas-fired hot water boilers of rated inputs between 70 kW (net) and 1.8 MW (net) (2nd and 3rd family gases).

- BS 6891:2005+A2:2008 - Installation of low pressure gas pipework of up to 35 mm (R1 1/4) in domestic premises (2nd family gas) specification.

- BS 5482-1:2005 - Code of practice for domestic butane and propane gas burning installations. Installations at permanent dwellings, residential park homes and commercial premises, with installation pipework sizes not exceeding DN 25 for steel and DN 28 for corrugated stainless steel or copper.

- BS 5482-2:AMD 12046: June 2001 - Domestic butane and propane gas burning installations. Installations in caravans and non-permanent dwellings.

- BS 5482-3:2005 - Domestic butane and propane gas burning installations. Installations in boats yachts and other vessels.

- Building regulations issued by Department of the Environment and Building Standards Regulations.

- Gas safety (Installation and Use) Regulations current issue.

- BS 6700 - Design, installation, testing and maintenance of services supplying water for domestic use within buildings and their cartilages - Specification.

- UK Health and safety at work Act.

- All relevant Building Regulations.

- Local Water Bye Laws.

- Water Regulations.

- Health & Safety legislation.

Failure to install this appliance correctly could lead to prosecution. It is your own interest and that of safety to ensure that the law is complied with. Manufacturer's instructions must not be interpreted as over-riding statutory obligations under any circumstances.

2 - GENERAL INFORMATION

2.1 - Presentation

Congratulations! You have purchased one of the best products on the market. Each individual part is proudly designed, manufactured, tested and assembled within the COSMOGAS facilities, thus guaranteeing the best quality control.

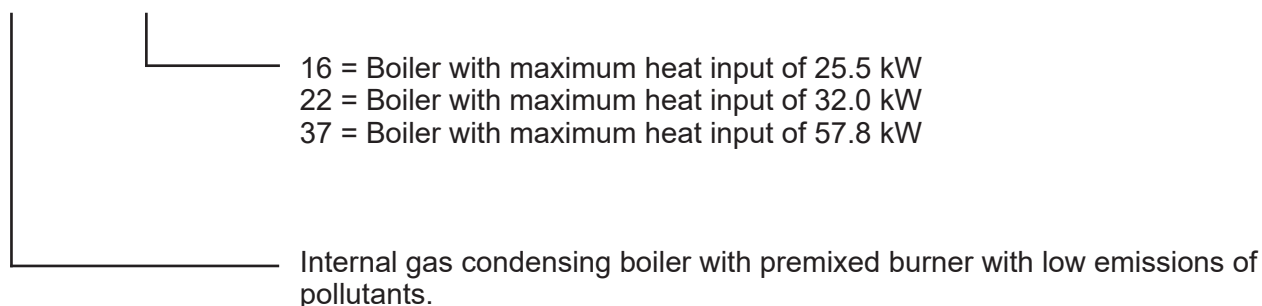

2.2 - Overview of models

AGUADENS XX



2.3 - Accessories

☞ The accessories, in some models, could be not supplied with the appliance.

Quantity No.	Description		Figure
N° 1	LOWER COVER	Only in the 16 and 22 models	
N° 1	GAS CONVERSION KIT		
N° 1	PREINSTALLATION TEMPLATE	Only in the 16 and 22 models	

2.4 - Manufacturer

COSMOGAS srl
Via L. da Vinci 16
47014 - Meldola (FC) Italy
Tel. (+39) 0543 498383
Fax. (+39) 0543 498393
www.cosmogas.com
info@cosmogas.com

2.5 - Meaning of symbols used



WARNING!

Danger of electric shocks. If these warnings are not heeded it can jeopardise correct operation of the boiler or cause serious injury or damage to people, animals or things.



WARNING!

Generic danger. Failure to comply with these warnings may jeopardise the working order of the appliance or cause serious damage or injury to persons, animals or things.

 Important indication symbol

2.6 - Maintenance

A regular annual maintenance check on the appliance is advised for the following reasons:

- to maintain high efficiency and manage the domestic hot water system economically (with low fuel consumption);
- to achieve a high level of operating safety;
- to maintain a high level of environmental combustion compatibility.

Offer your customer a scheduled maintenance contract.

2.7 - Disposal



The crossed wheeled bin symbol means that the product must not be thrown away in the ordinary rubbish bin (i.e. in with "mixed urban rubbish"); it must be dealt with separately, in order to undergo suitable operations for it to be reused or treated, so that any substances that are dangerous for the environment can be removed and disposed of safely. This will enable all the raw materials to be recycled. The user is responsible for getting rid of the boiler at the end of its life, delivering it to a recycling centre run by the local authority or city hygiene companies, or, when he/she buys a new boiler, giving the product that has been replaced to the dealer, who is obliged to take it under the terms of EU Directive 2012/19/EU. For further information regarding correct decommissioning of these appliances, users can contact the public service in charge or retailers.

3 - MAIN COMPONENTS

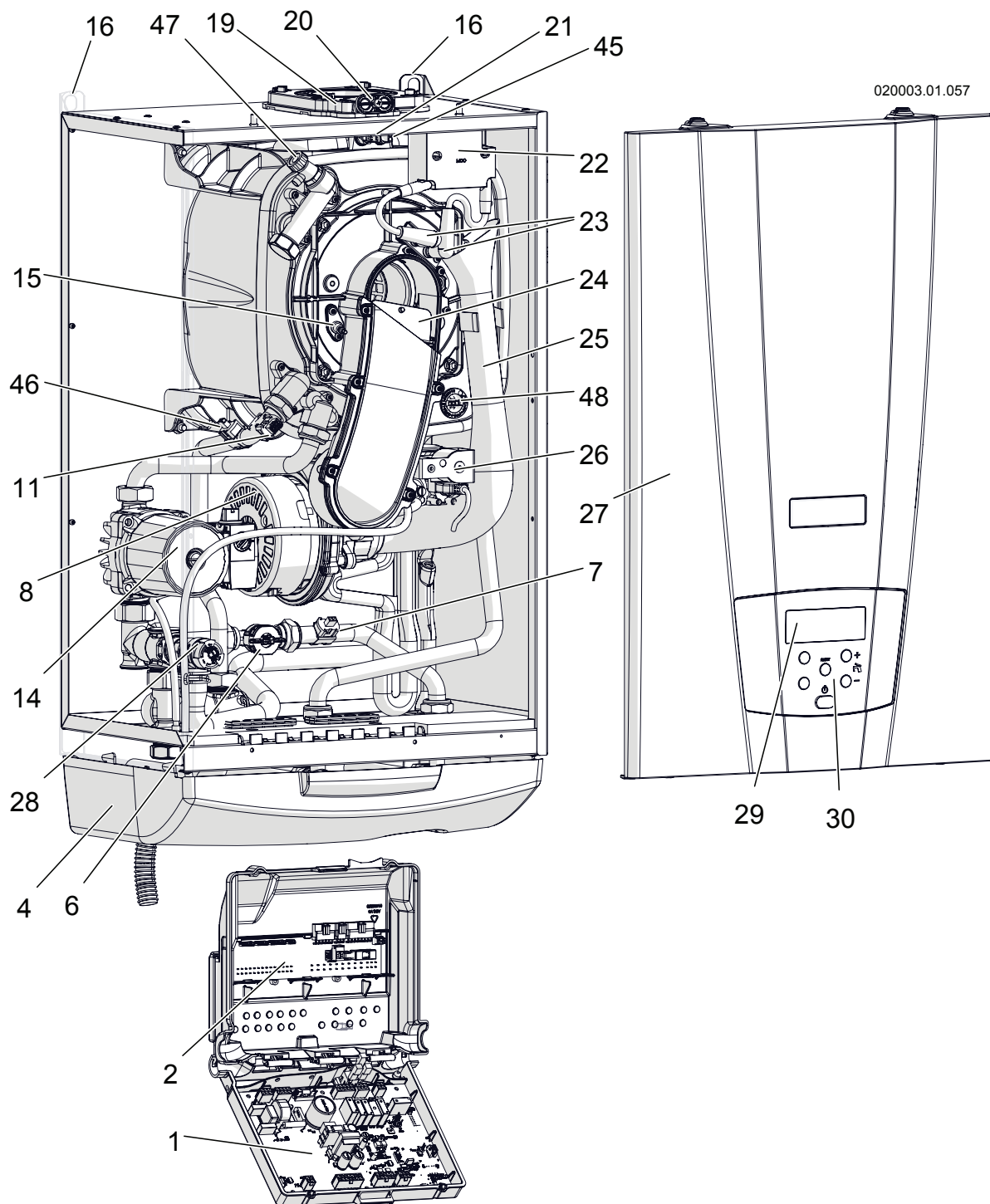

- | | |
|--|---|
| 1 - Command and control board | 17 - ----- |
| 2 - Electric connections board | 18 - ----- |
| 3 - ----- | 19 - Air intake and burned gas exhaust fittings |
| 4 - Lower cover | 20 - Combustion analysis points |
| 5 - ----- | 21 - Flue gas temperature sensor (1006). |
| 6 - Water flow rate gauge | 22 - Spark generator |
| 7 - Cold water inlet temperature sensor (1007) | 23 - Ignition cables |
| 8 - Fan | 24 - Back flue preventer valve |
| 9 - ----- | 25 - Air inlet manifold |
| 10 - ----- | 26 - Gas valve |
| 11 - Dual DHW outlet sensor (1001 and 1005) | 27 - Front casing |
| 12 - ----- | 28 - Safety valve |
| 13 - ----- | 29 - Display |
| 14 - Pump | 30 - Control panel |
| 15 - Detection electrode | 31 - ----- |
| 16 - Support brackets | |

Figure 3-1 - Internal components of AGUADENS 16 and 22

3 - MAIN COMPONENTS

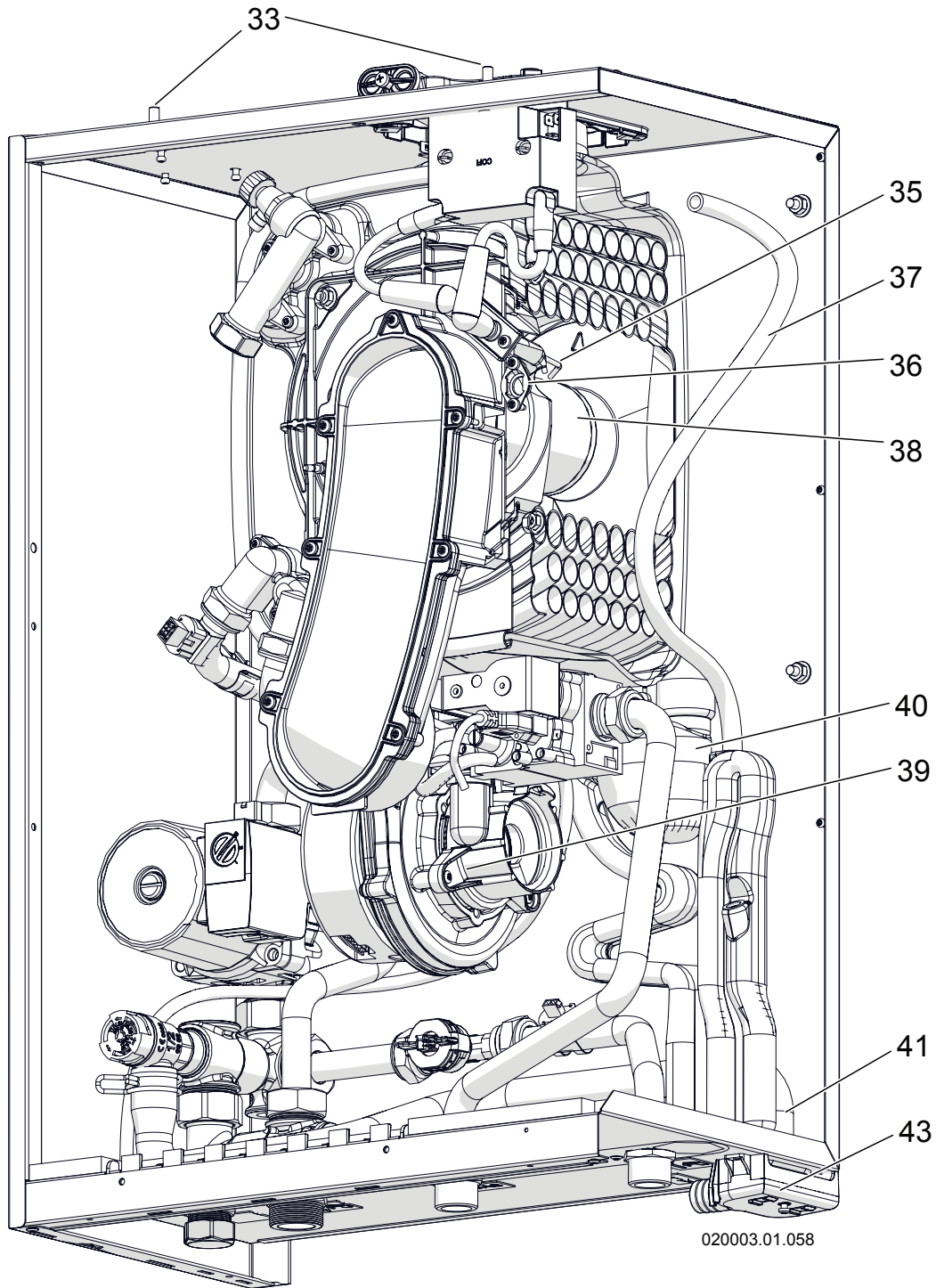

020003.01.058

- | | |
|---|---|
| 32 - ----- | 45 - Flue gas temperature fuse |
| 33 - Front casing couplings | 46 - DHW temperature sensor (100 ^o C) |
| 34 - ----- | 47 - Air vent valve |
| 35 - Ignition electrodes | 48 - Primary heat exchanger temperature fuse |
| 36 - Burner pilot light | |
| 37 - Drain pipe for any water coming from the combustion agent air pipe | |
| 38 - Burner | |
| 39 - Air/gas mixing group | |
| 40 - Condensate drain siphon | |
| 41 - Safety valve drain pipe | |
| 42 - ----- | |
| 43 - Condensate collection tank | |
| 44 - ----- | |

Figure 3-2 - Internal components of AGUADENS 16 and 22

3 - MAIN COMPONENTS

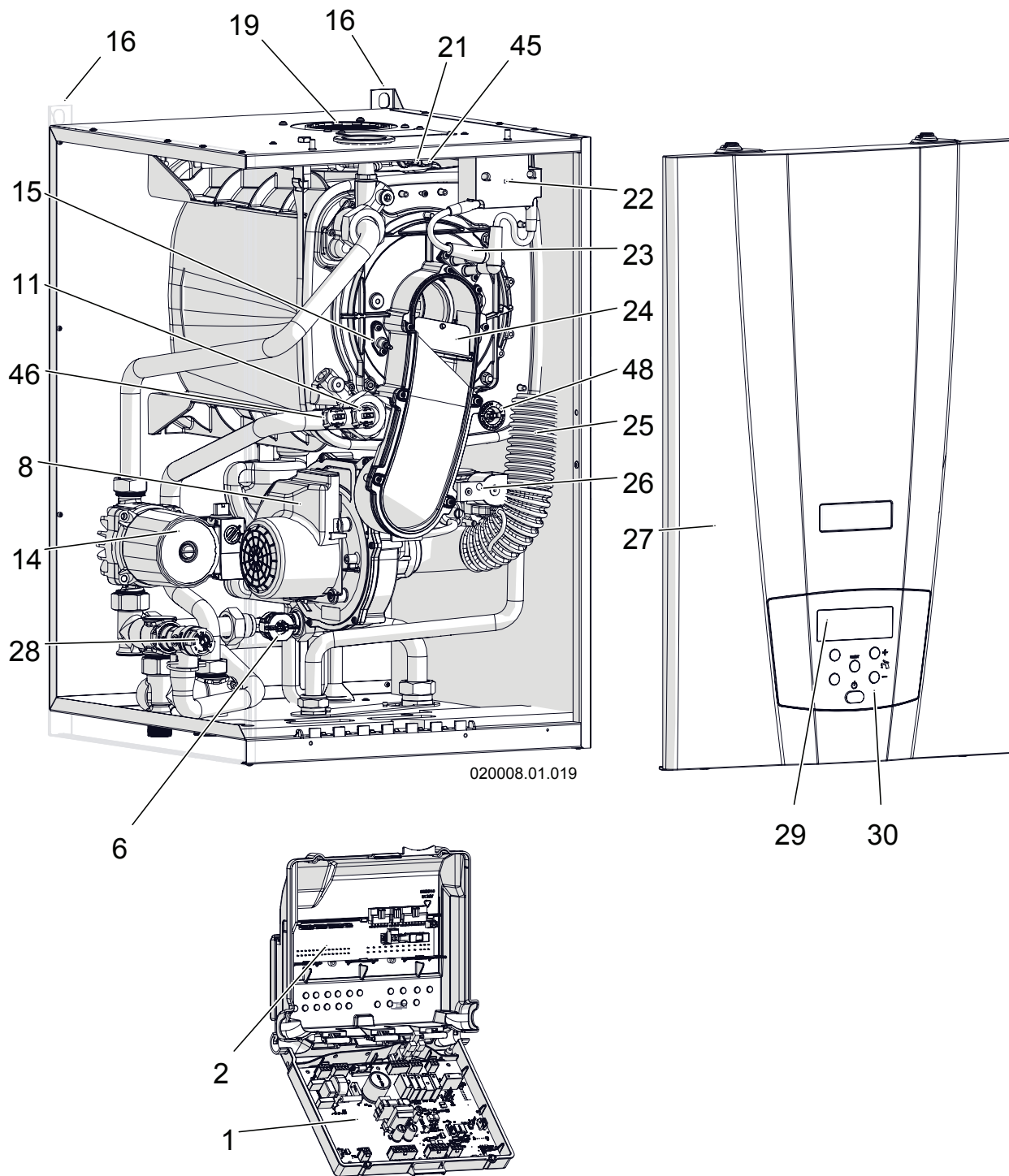

- | | |
|--|---|
| 1 - Command and control board | 16 - Support brackets |
| 2 - Electric connections board | 17 - ----- |
| 3 - ----- | 18 - ----- |
| 4 - ----- | 19 - Air intake and burned gas exhaust fittings |
| 5 - ----- | 20 - ----- |
| 6 - Water flow rate gauge | 21 - Flue gas temperature sensor (1006) |
| 7 - Cold water inlet temperature sensor (1007) | 22 - Spark generator |
| 8 - Fan | 23 - Ignition cables |
| 9 - ----- | 24 - Back flue preventer valve |
| 10 - ----- | 25 - Air inlet manifold |
| 11 - Dual DHW outlet sensor (1001 and 1005) | 26 - Gas valve |
| 12 - ----- | 27 - Front casing |
| 13 - ----- | 28 - Safety valve |
| 14 - Pump | 29 - Display |
| 15 - Detection electrode | 30 - Control panel |
| | 31 - ----- |

Figure 3-3 - Internal components of AGUADENS 37

3 - MAIN COMPONENTS

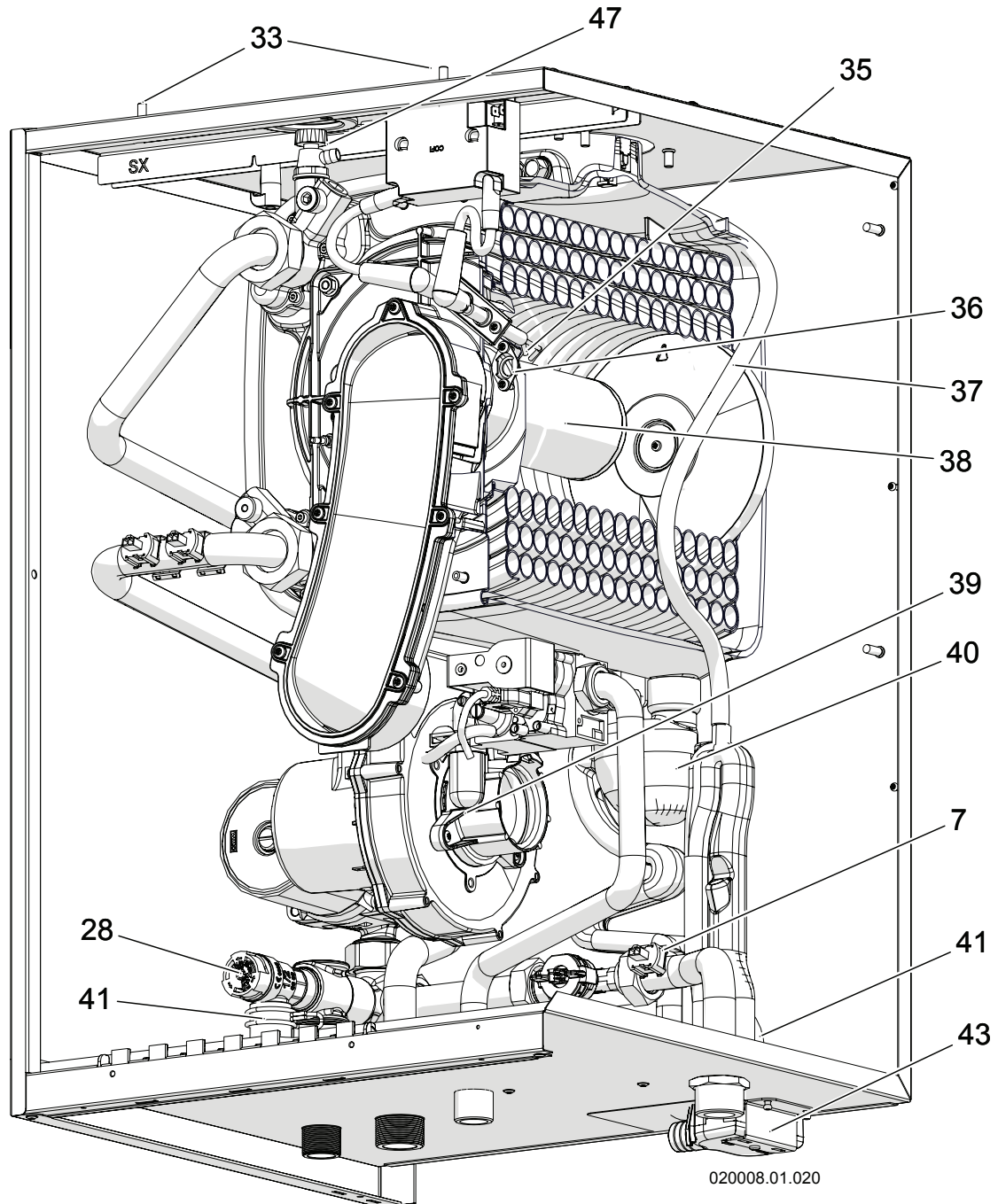

- 32 - -----
- 33 - Front casing couplings
- 34 - -----
- 35 - Ignition electrodes
- 36 - Burner pilot light
- 37 - Drain pipe for any water coming from the combustion agent air pipe
- 38 - Burner
- 39 - Air/gas mixing group
- 40 - Condensate drain siphon
- 41 - Safety valve drain pipe
- 42 - -----
- 43 - Condensate collection tank
- 44 - -----
- 45 - Flue gas temperature fuse
- 46 - DHW temperature sensor (100°C)
- 47 - Air bleed valve
- 47 - Air vent valve
- 48 - Primary heat exchanger temperature fuse

Figure 3-4 - Internal components of AGUADENS 37

4 - OPERATION

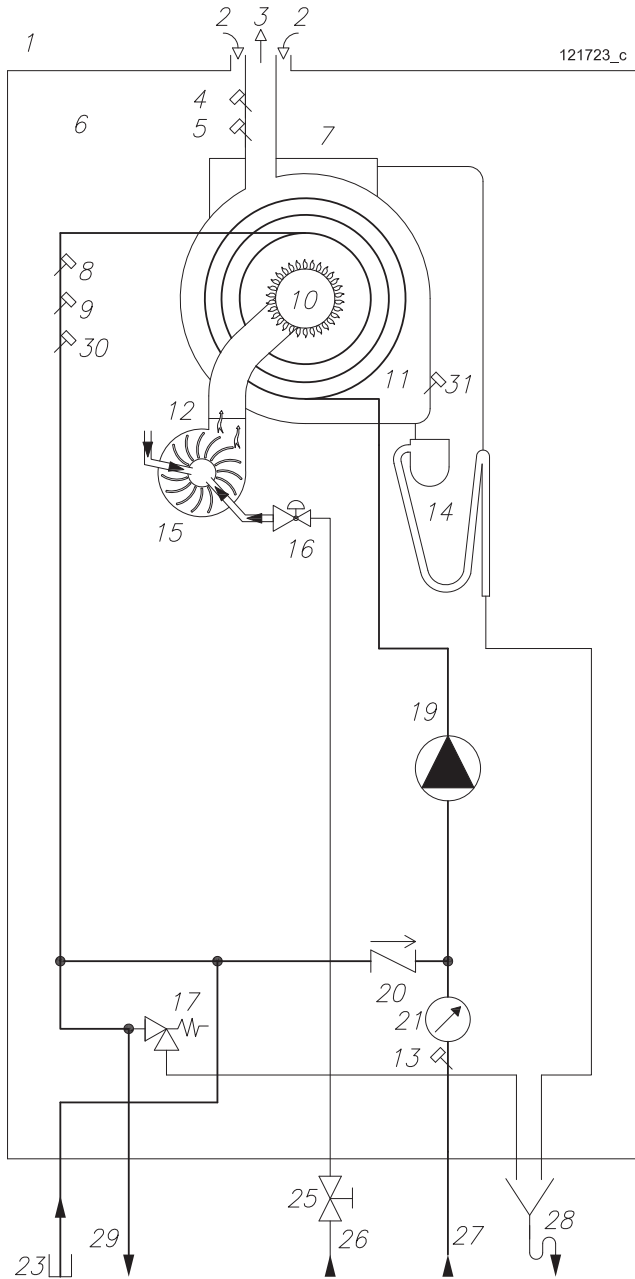

Figure 4-1 – AGUADENS Hydraulic layout

Figure 4-1 Key:

- 1 = Hot water heater
- 2 = Combustion agent air inlet
- 3 = Flue gas outlet
- 4 = Flue gas temperature sensor (Par. 1006)
- 5 = Flue gas temperature fuse
- 6 = Sealed chamber
- 7 = Water collection pipe coming from the combustion agent inlet pipe
- 8 = Sensor 1 DHW outlet temperature (Par. 1001)
- 9 = Sensor 2 DHW outlet temperature (Par. 1005)
- 10 = Burner
- 11 = Heat exchanger
- 12 = Fan
- 13 = Cold water inlet temperature sensor (Par. 1007)
- 14 = Condensate collection siphon with sediment decanter
- 15 = Air/gas mixer
- 16 = Gas valve
- 17 = Safety valve
- 18 = -----
- 19 = Pump
- 20 = Check valve
- 21 = Domestic hot water flow rate gauge
- 22 = -----
- 23 = Recirculation
- 25 = Gas cock
- 26 = Gas inlet
- 27 = Domestic cold water inlet
- 28 = Collector for condensate drain and safety valve
- 29 = Domestic hot water outlet
- 30 = DHW temperature sensor (Par. 1002)
- 31 = Primary heat exchanger temperature fuse

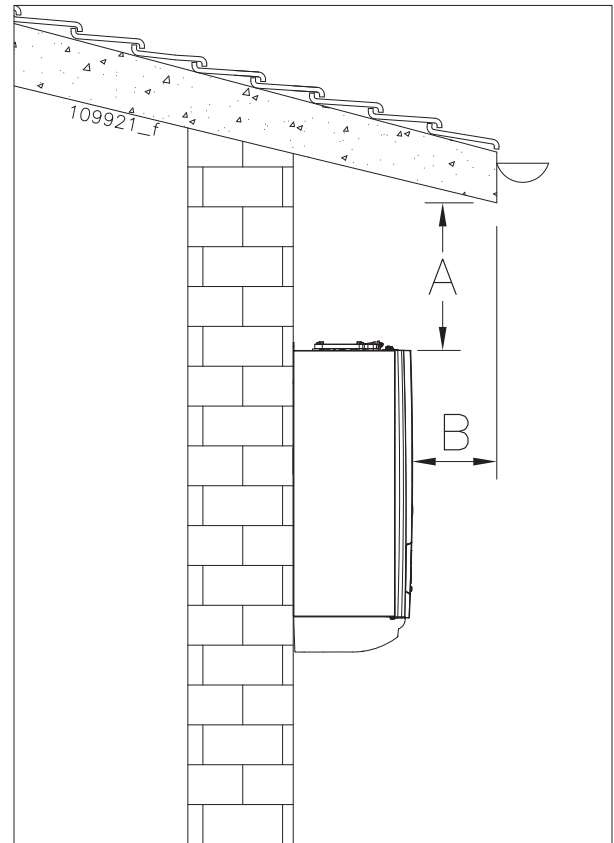

Figure 4-2 key – Distances “A” and “B” must be assessed during installation so that rain does not reach the appliance directly.

Figure 4-2 – Example of a partially protected place

4 - OPERATION

4.1 - Operation and intended use of the appliance

This product is a condensing gas appliance, intended for the production of domestic hot water for civil use. Consider the head losses shown in Figure 4-3.

The temperature of the domestic hot water is adjusted following the procedure in Section 7.3.

- ☞ This appliance must be connected to a domestic hot water distribution network, compatible with the features, performance and power of the appliance itself.
- ☞ Before installation, carefully wash out the domestic hot water system to remove any possible residues or impurities that might compromise operation of the boiler.

☞ This appliance is not designed to be exposed to temperatures below zero and above 50°C. Choose a place that is sheltered from the weather and from frost; it can be installed outside, in a place partially protected from rain, snow and hail, such as a balcony or porch (see Figure 4-2).

☞ Check Figure 5-1 concerning the minimum safety distances for installation and future maintenance.

Key for Figure 4-3

- A = Aguadens 16
- B = Aguadens 22
- C = Aguadens 37

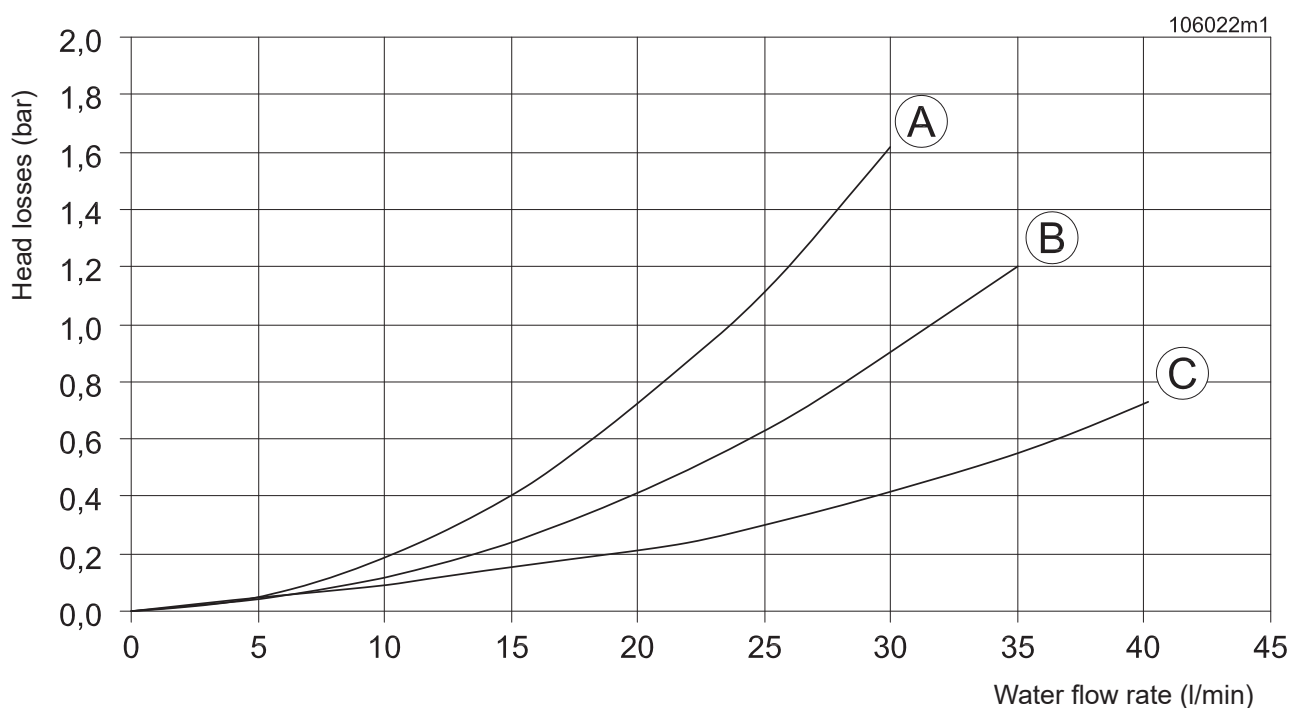

Figure 4-3 – Domestic hot water head losses curve

4.2 - Examples of installation

In Figures 4-4, 4-5, 4-6, 4-7, 4-8 and 4-9 you can see some examples of correct installation while in Figure 4-10 you can see an example of incorrect installation.

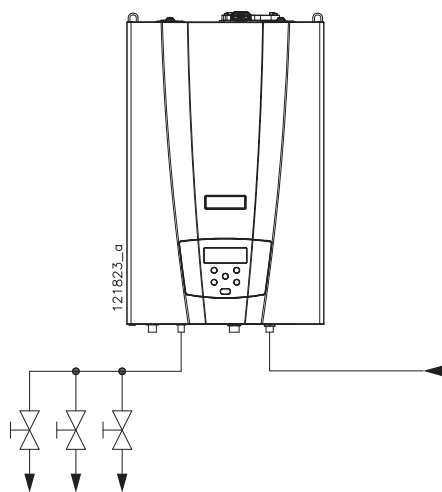

Figure 4-4 - Example of system without recirculation

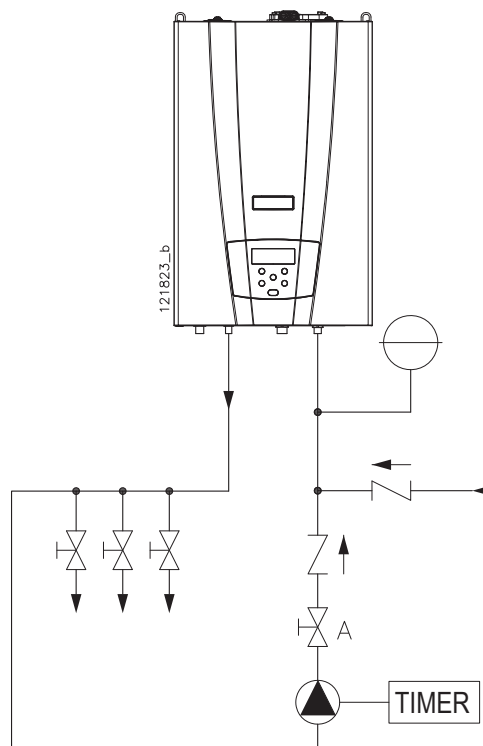

Figure 4-5 - Example of system with recirculation and external pump (see Section 5.12)

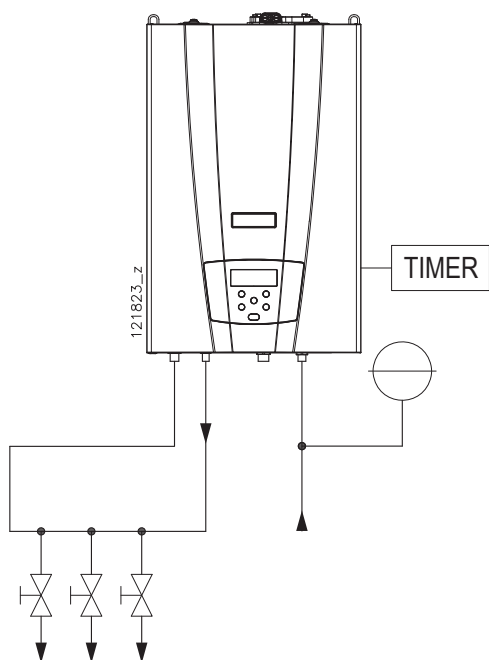

Figure 4-6 - Example of system with recirculation and internal pump (see Section 5.13)

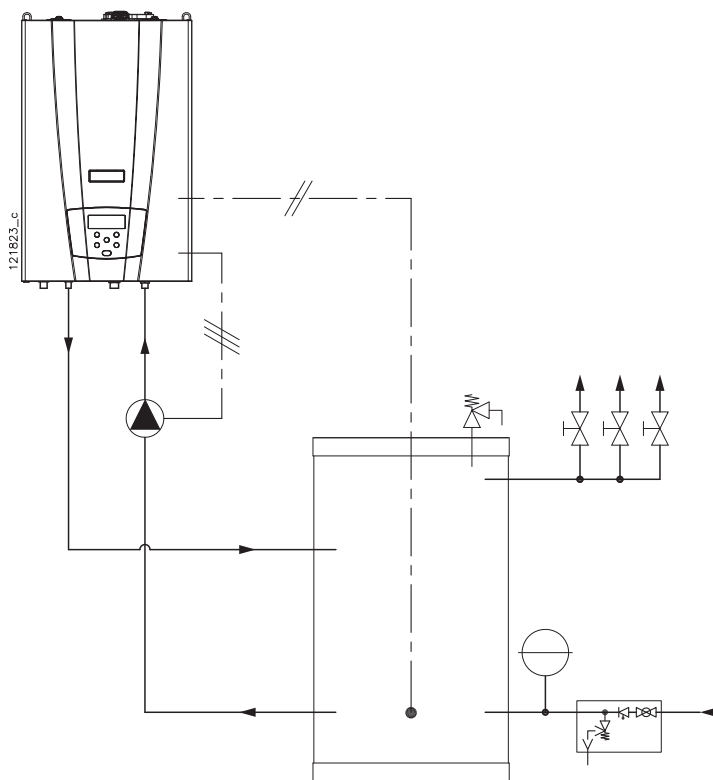

Figure 4-7 - Example of system with storage tank (Section 5.14)

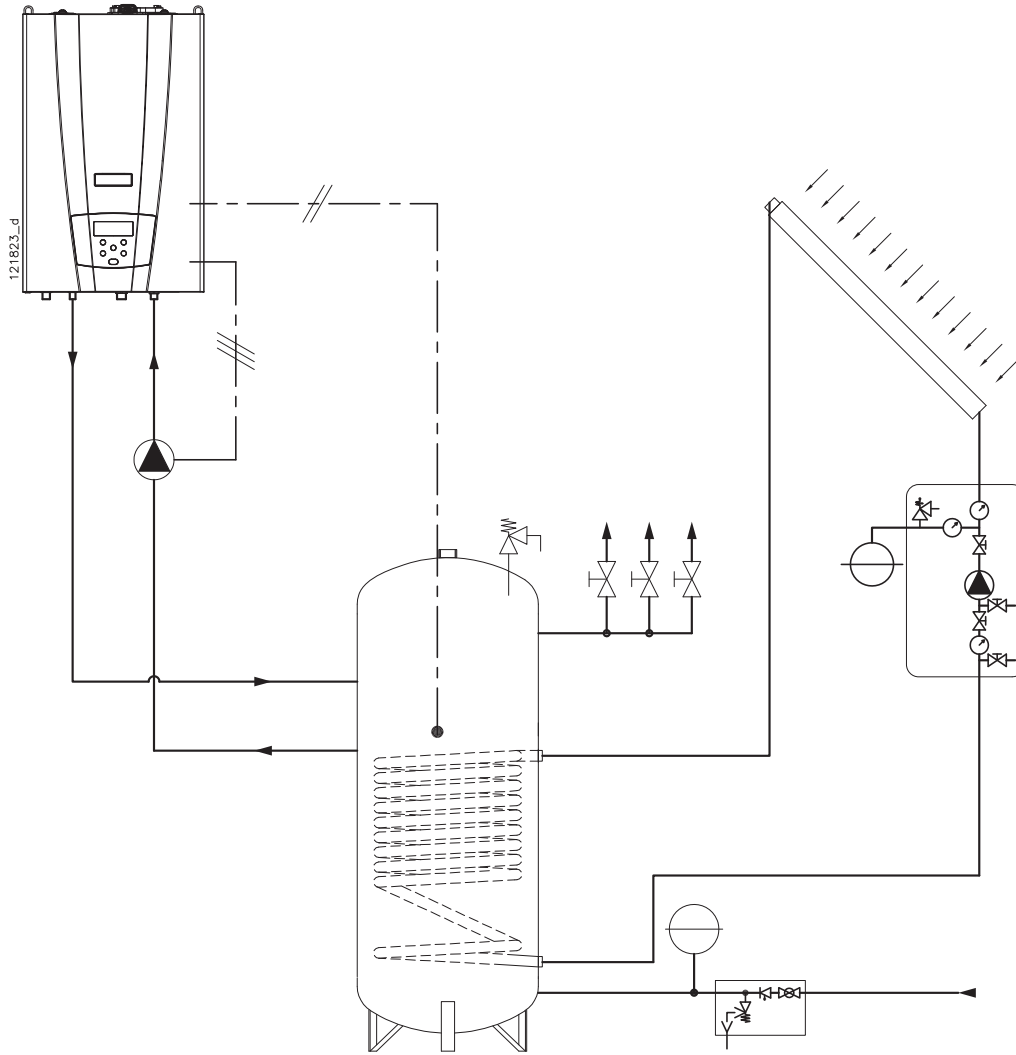

Figure 4-8 - Example of system with solar panels and storage tank (Section 5.14)

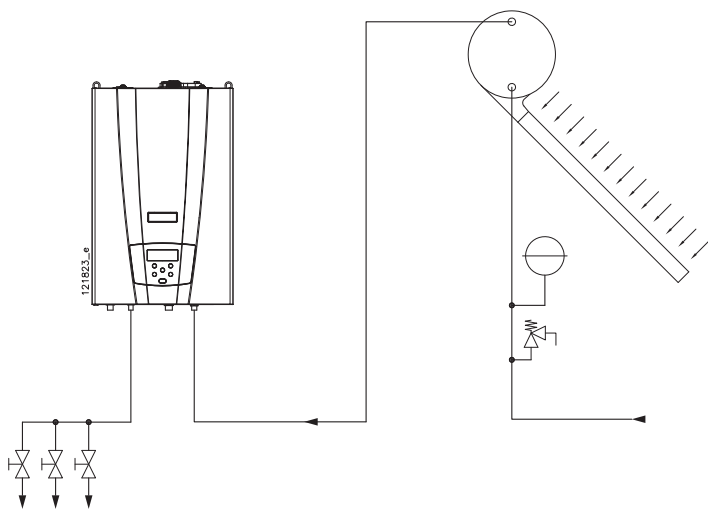

Figure 4-9 - Example of system with solar panel with natural circulation (maximum temperature of the hot water heater water is 85°C).

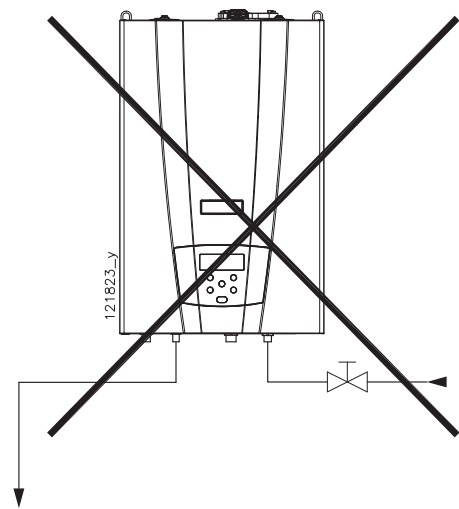

Figure 4-10 - Example of incorrect installation

5 - INSTALLATION

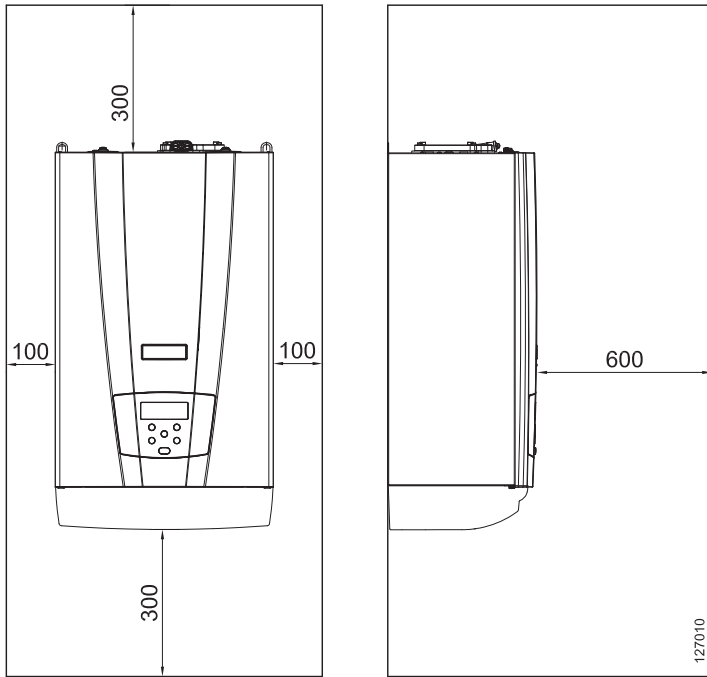

Figure 5-1 - Minimum safety distances for installation and future maintenance

5.1 - Opening the package

The boiler is supplied in a cardboard package. To open it, follow the instructions given on the package's closing flaps.

5.2 - Dimensions and minimum distances to be observed

For both installation and maintenance, it is necessary to leave free spaces around the boiler, as shown in figure 5-1.

5.3 - Choosing where to install the appliance



WARNING! The appliance must be installed exclusively on a solid, vertical wall, which can bear the weight.

The appliance must be installed inside your home, or otherwise protected from atmospheric agents such as rain, wind, sun, and especially frost.

Choose the room and suitable position for installation, taking into account the following factors:

- connection of the flue gas exhaust/air intake pipes;
- connection of the gas supply pipe;
- connection of the water supply;
- connection of domestic hot water system;
- electric connection;
- connection of the drain for the condensate produced by the boiler and of the safety valve drain.



WARNING! This appliance must be installed in a place where water leakages from the appliance itself, from the joints between the pipes or from any drainage from the safety valve, cannot cause damage to materials or items below it.



WARNING! The room where this appliance is installed must have a water collection and discharge point for any leakage.

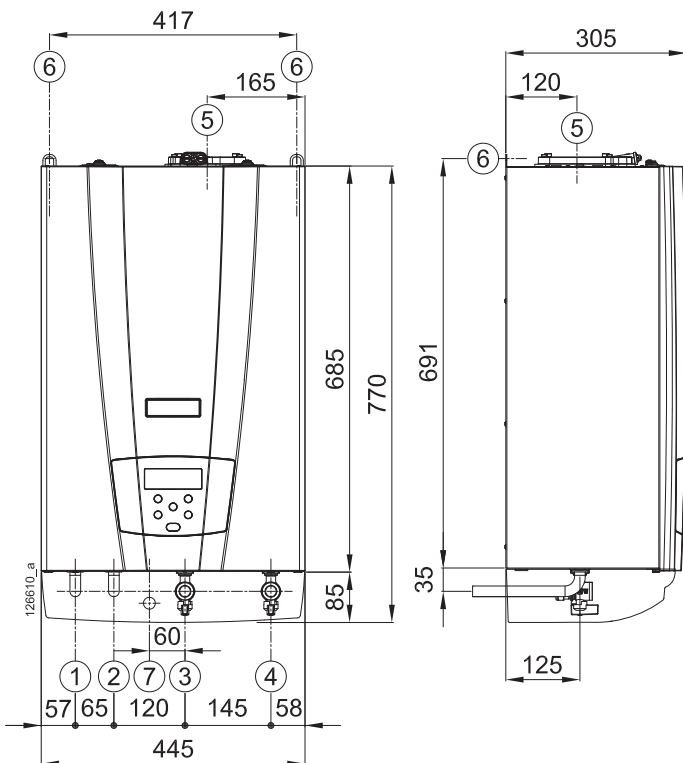

- 1 - Recirculation 3/4"
- 2 - DHW outlet 1"
- 3 - 3/4" gas inlet
- 4 - 3/4" cold water inlet
- 5 - Flue gas exhaust / Air intake
- 6 - Support attachments
- 7 - Ø20 condensate drain

Figure 5-2 – Dimensions and attachments centre-to-centre distances. Models 16 and 22

5 - INSTALLATION

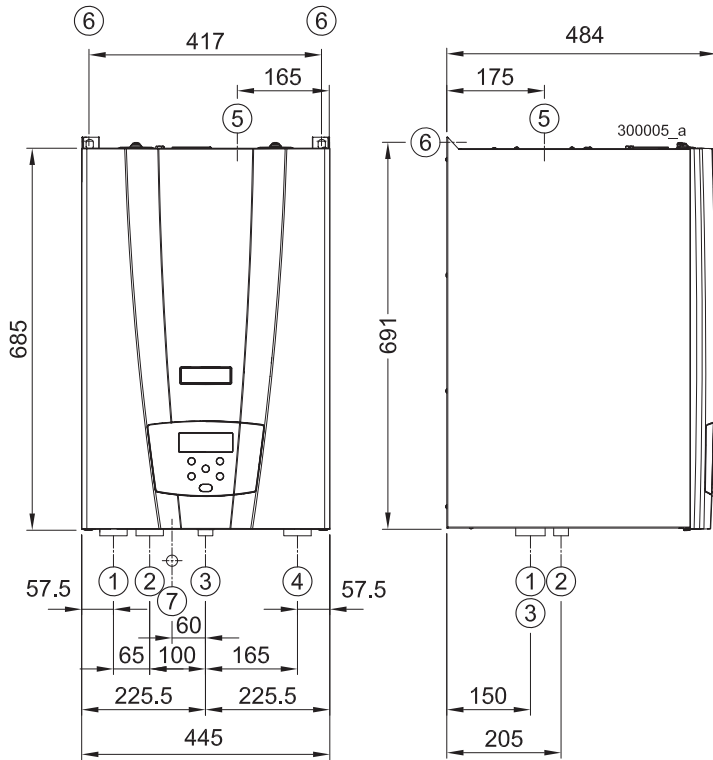

- 1 - Recirculation 3/4"
- 2 - DHW outlet 1"
- 3 - 3/4" gas inlet
- 4 - 1" cold water inlet
- 5 - Flue gas exhaust / Air intake
- 6 - Support attachments
- 7 - Condensate drain

Figure 5-3 – Dimensions and attachments centre-to-centre distances Model 37

5.4 - Unit assembly

Refer to Figure 5-4:

- 1.- Put the paper template, provided with the appliance, against the wall (not provided with AGUADENS 37);
- 2.- Check that the template is square (for AGUADENS 37 check measurements in Figure 5-3);
- 3.- Mark the holes for the plugs and hydraulic fittings on the wall;
- 4.- Remove the paper template (where present);
- 5.- Make holes "A" and insert the wall plugs "B";
- 6.- Make the boiler hydraulic and gas connections;
- 7.- Hang the boiler on the plugs "C";
- 8.- Make the hydraulic connections.

5.5 - Domestic hot and cold water



WARNING! If the hardness of the water is higher than 20°F (200 mg/l), a water softener must be installed on the cold water inlet.



WARNING! If the hot water heater has to work at temperatures above 60°C, the hardness of the water must be less than 15°F (150 mg/l).



WARNING! The water must not be softened to values lower than 5°F (50 mg/l). At these values it becomes acidic and can corrode parts of the hot water heater, shortening its life.



WARNING! The acidity of the water must have a pH value between 6.5 and 8.5. A value outside this range is corrosive, can cause damage to the heat exchanger and/or to the pipes.



WARNING! Install a filter with mesh no wider than 0.5 mm² in the domestic cold water inlet.



WARNING! The domestic hot water circuit must be made with materials resistant to temperatures of at least 95°C and a pressure of 10 bar. Otherwise (e.g. with plastic piping), the system must be fitted with the relevant protection and safety devices.

In Figures 5-2 and 5-3, you can verify the position of the domestic hot and cold water fittings. Insert a closing cock before the cold water inlet, useful for maintenance work.

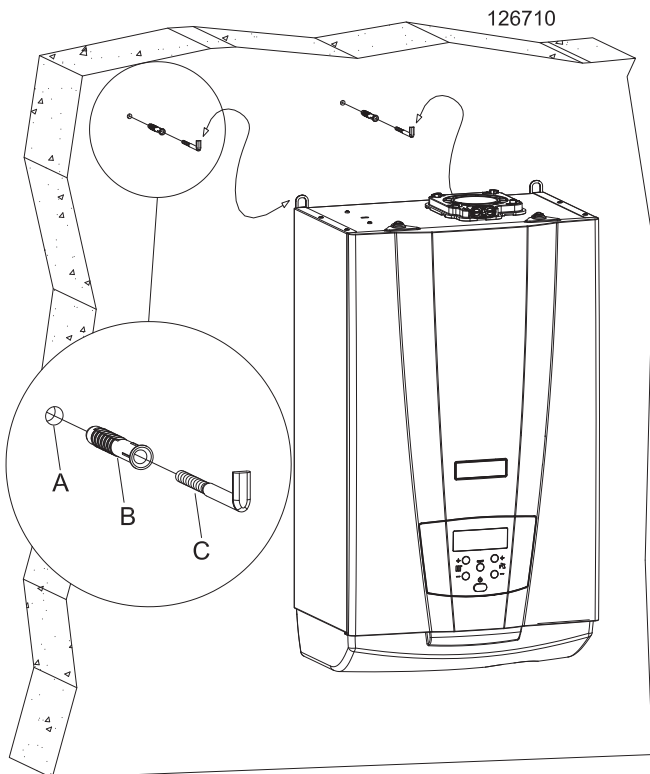

Figure 5-4 – Support plugs

5 - INSTALLATION

5.6 - Gas



WARNING! Do not power the appliance with gases other than those specified.



WARNING! Check that the gas and supply pressure are those for which the boiler has been adjusted.

Two situations are possible:

- A - the gas and supply pressure correspond to the adjustment of the boiler. In this case, it can be connected;
- B - the gas and supply pressure do not correspond to the adjustment of the boiler. In this case, the boiler must be converted to the type of gas and supply pressure corresponding to those of the supply available.

The boiler is provided with the relevant gas conversion kit.

- ☞ Before installation, clean the inside of the gas supply pipe thoroughly.
- ☞ a shut-off cock must be installed on the gas supply pipe near to the appliance.



WARNING! Before supplying gas to the appliance, carry out a test of the gas system seal, as required by the technical standards in force.

- ☞ To prevent damage to the appliance gas control unit, run a leak test at a pressure not exceeding 50 mbar.
- ☞ If the gas system must be inspected at pressures over 50 mbar, turn the cock located immediately before the boiler, to isolate it from the system.

Use Figures 5-2 and 5-3 to check the position of the appliance gas fitting. The cross-sections of the pipes in the gas supply system must always guarantee a gas supply that is sufficient to cover the maximum demand.

5.7 - Condensate drain

There is a siphon inside the boiler for the evacuation of condensate (see Figures 3-2 and 3-4, detail "40") and to prevent combustion products from escaping. The end of the siphon corresponds to pipe "F" in Figure 5-5. This end must be conveyed into another, anti-odour siphon (Figure 5-8, detail "G") to prevent bad odours returning into the environment (anti-odour siphon "G" is supplied on request). In particular, the condensate drain system must:

- ☞ Be for rooms used for residential purposes and for offices with more than 10 users; it can be connected to the domestic waste disposal plant by means of appropriate siphon with disjunction, capable of preventing the pressurisation of the system (the siphon is inside the boiler) and the return of bad odours from the sewers (detail "G" in Figure 5-8). If the room used for office purposes has fewer than 10 users, before connecting up the domestic waste drain, install a condensate neutraliser (see Section 9 for the acidity value of the condensate and the quantities).
- ☞ Be performed with a pipe with an internal diameter equal to or greater than 13 mm.
- ☞ Be installed in such a way as to prevent the liquid from freezing; therefore pay attention to any external Sections. It is prohibited to drain into gutters or rainwater drainpipes.
- ☞ Slope continuously towards the drain point; avoid high points, which could pressurise the pipe.

5.8 - Safety valve

The appliance is protected against overpressures by a safety valve calibrated to 10 bar (see Figures 3-1 and 3-4 detail "28").

The safety valve drain must be conveyed to pipe "F" in Figure 5-5, which must then be taken to the anti-odour siphon (detail "G", Figure 5-8). This drain with a siphon is used to prevent overpressures if the valve is opened, and it allows the user to check possible intervention.

The anti-odour siphon "G" in Figure 5-8 is provided on request.



WARNING! If the safety valve is not connected to the drain, whenever the valve intervenes, it could cause damage to persons, animals or objects.

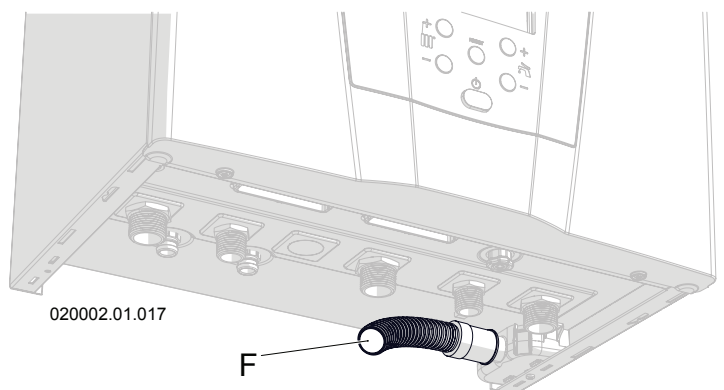

Figure 5-5 – Condensate drain pipe

5 - INSTALLATION

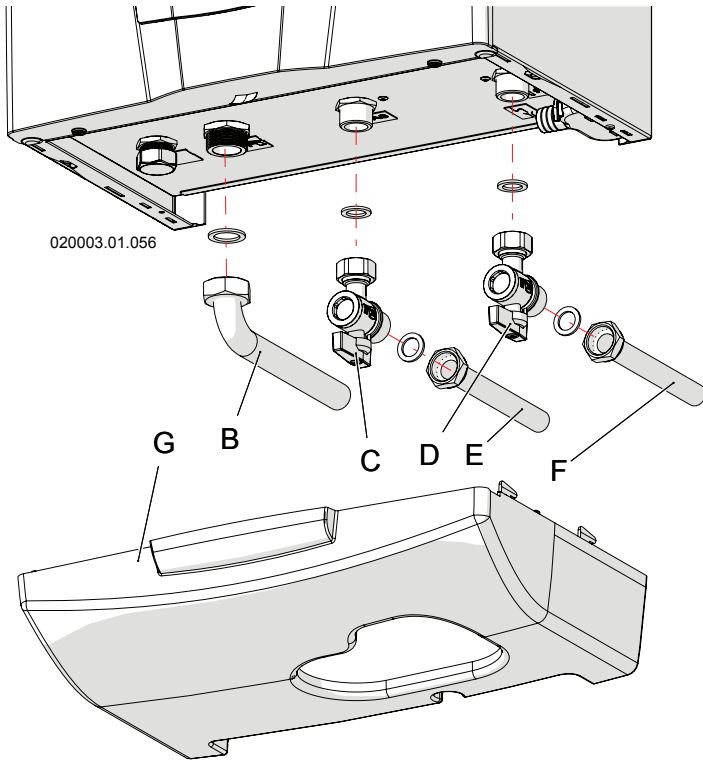

Figure 5-6 – Water and gas connections
AGUADENS 16 and 22

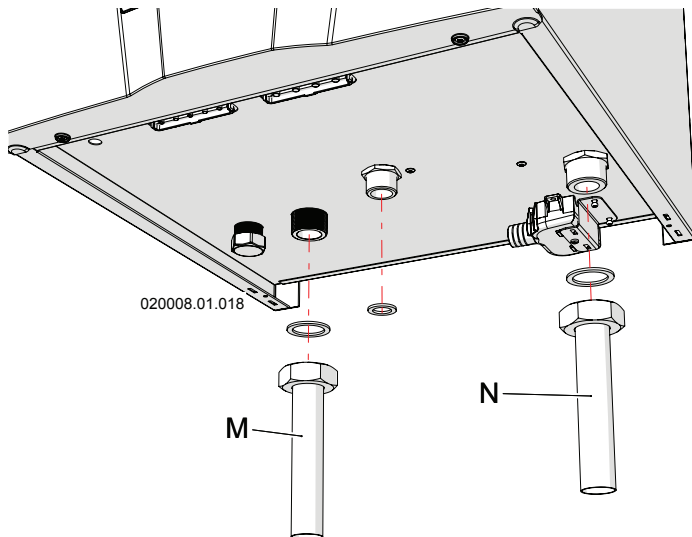

Figure 5-7 – Water and gas connections
AGUADENS 37 (Cocks not provided)

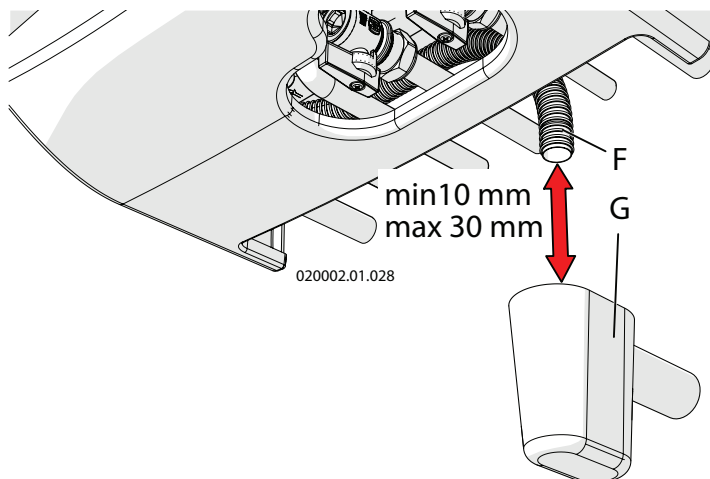

Figure 5-8 - F = Condensate drain pipe
G = anti-odour siphon (on request)

5.9 - Hydraulic and gas connections, and mounting of the lower cover

The accessories, in some models, could be not supplied with the appliance.

Models 16 and 22 are shown in Figure 5-6:

B = domestic hot water \varnothing 22;

C = 3/4" gas inlet cock (EN 331 type-approved);

D = 3/4" domestic cold water inlet cock;

E = gas \varnothing 18;

F = domestic cold water \varnothing 18;

Once the hydraulic and gas connections have been made, proceed with assembly of the lower cover "G" as shown in Figure 5-6.

Model 37 is shown in Figure 5-7:

M = domestic hot water \varnothing 22;

N = domestic cold water \varnothing 22;

5.10 - Polyphosphate softener (on request)

If the boiler is installed in a geographical area where domestic hot water is of a hardness exceeding 20°F (200 mg/l), a polyphosphate softener must be installed on the cold water supply, in order to safeguard the appliance against limescale deposits.

Key to Figure 5-9:

2 = Gas cock (EN 331 type approved) (responsibility of installer)

3 = Water inlet cock / Flow rate selector switch (responsibility of installer)

4 = Drain valve (responsibility of installer)

5 = Condensate drain (responsibility of installer)

6 = Gas inlet

7 = Cold water inlet

8 = Domestic hot water

9 = Condensate drain pipe

10 = Shut-off valve (responsibility of installer)

11 = Filter (responsibility of installer)

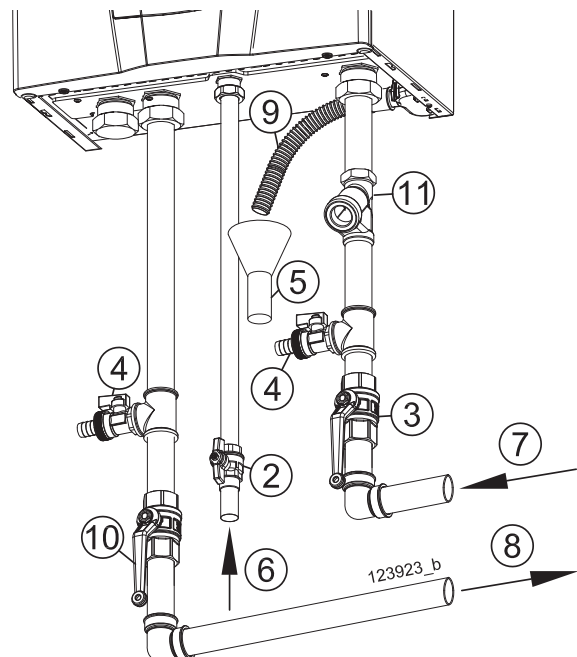

Figure 5-9 - Example of typical full installation

5 - INSTALLATION

5.11 - Electrical connections: details



WARNING! The appliance is only electrically safe when it has been correctly connected to an efficient earth circuit, performed as provided for by the current safety regulations.

This fundamental safety requirement must be met. If in doubt, request a thorough check of the electrical system by a professionally qualified technician.

- ☞ Have a professionally qualified technician check that the electrical system is suitable for the electric power required by the appliance, as indicated on the plate.
- ☞ The appliance must be connected to the mains electricity with a movable plug connection. The use of adapters, multiplugs, extension leads, etc. is not permitted.
- ☞ The appliance must be connected to the mains electricity using a three-pole electric cable, with double insulation, a minimum section of 1.5 mm² and resistance to a minimum temperature of 70°C (characteristic T).

- ☞ For connection to mains electricity, a two-pole switch must be installed near the appliance with a contact opening distance of at least 3 mm, as envisioned by the current sector regulations.
- ☞ Respect the polarity between the neutral and phase wires when connecting the appliance.
- ☞ Make sure that the system pipes are not used as earthing points for the electrical system or telephone lines. This piping is not suitable for this purpose; serious corrosion damage would occur in a very short time to the appliance, piping and radiators.



WARNING! The boiler is not protected against the effects caused by lightning.

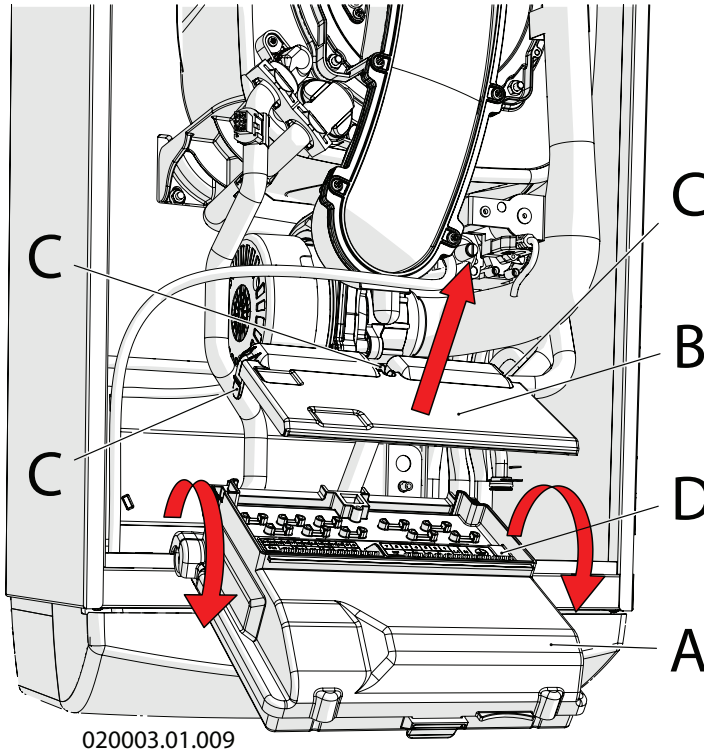

Figure 5-10 key

- A = Control panel box;
- B = Electrical connections board cover;
- C = Connections cover closing flaps;
- D = Electrical connections board;

Electrical contacts key

- AL Slave = Not used
- CH = Not used
- AD = Not used
- TA = Remote timer control CR04 (where present)
- SE = Not used
- SB = Storage tank probe (where present)
- MF = Alarm output
- EP = Boiler pump (where present);
- DN = Not used
- (2 = Neutral; 3 = Line)
- L1 = Boiler power supply line
- N = Boiler power supply neutral
- EARTH SYMBOL = Earth contacts

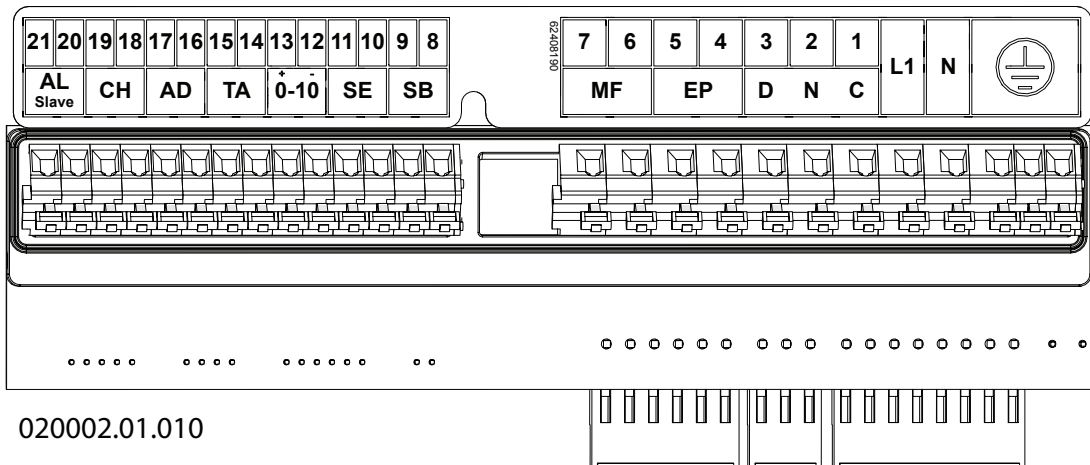

Figure 5-10 – Electrical connections

5 - INSTALLATION

5.11.1 - Connecting power supply cable

To connect the power supply cable proceed as follows (refer to Figure 5-10):

- 1.- Use a three-pole dual-insulation cable, with a minimum cross-section of 1.5 mm²;
- 2.- Remove the casing from the appliance, following the relevant instructions in Section 8.3;
- 3.- Rotate panel "A" towards the front of the boiler;
- 4.- Use the flaps "C" and open the lid "B" as indicated by the arrow;
- 5.- Lay the power supply cable through the fairlead near the contacts "L1", "N" and the earth symbol;
- 6.- Strip the cable, making sure that the earth wire (yellow/green) is kept 20 mm longer than the other two;
- 7.- Connect the yellow/green cable to the earth terminal (see symbol);
- 8.- Connect the brown cable (Phase) to terminal L1;
- 9.- Connect the blue cable (Neutral) to terminal N.

5.11.2 - CR04 remote time control (on request)

The CR04 remote control can interact with the appliance.

In order to connect the remote control cable, proceed as follows (refer to Figure 5-10):

- 1.- Use a two-pole cable, with a minimum cross-section of 1.5 mm², from the appliance to the CR04 remote control; The cable must also be shielded. The shield must be connected to the earth from the appliance side and the maximum length permitted is 100 metres;
- 2.- Remove the casing and access the junction box (see Section 8.3);
- 3.- Connect the 2 cable ends to boiler terminals "14" and "15" (TA) (see Figure 5-10);
- 4.- Connect the other two ends of the cable to the terminals on the remote control (follow the instructions in the remote control manual).



WARNING! As the CR04 remote control cables are subjected to a very low safety voltage (24 VDC), they must run in different ducts than the 230 VAC power supplies.

Once the CR04 remote control has been connected, all the domestic hot water temperature adjustments must be carried out directly on the remote control. Remember to follow the instructions in the CR04 remote control manual carefully.

5.11.3 - Alarm output

The alarm output closes whenever the appliance shows an error or locks.

To enable the alarm output, connect the cables to the "MF" terminals and set parameter $2156 = 6$.



WARNING! The alarm output is 230V and can supply a maximum load of 0,5A.

The alarm output is activated with a delay of 60 seconds from the display of the error or block.

5 - INSTALLATION

5.12 - Recirculation with external pump

If the appliance is designed to be installed with a recirculation circuit with an external pump (see Figure 4-5), you must:

- 1.- Set up the hydraulic installation as shown in Figure 4-5;
- 2.- Open a hot water cock to evacuate air from the system and accept that the hot water heater and the recirculation pump are working with no air;
- 3.- If it isn't already off, turn off the recirculation pump;
- 4.- Open a hot water cock and wait for the output temperature to stabilise;
- 5.- Close the domestic hot water cock;
- 6.- Check that 50 seconds after the cock is closed, the cock's icon on the display has stopped flashing;
- 7.- If the cock's icon is still flashing, it means that the appliance's internal pump can still circulate water in the recirculation circuit to a value of more than 2 l/min (verifiable on parameter **1062**).
- 8.- Use valve "A" in Figure 4-5 to take the recirculation flow rate back below 2 l/min;
- 9.- Now the appliance can begin to operate correctly again.



WARNING! If the appliance is connected to a domestic hot water recirculation circuit, install an expansion tank of a suitable size for managing the natural increase in the volume of water during heating.

5.13 - Recirculation with internal pump

If the appliance is designed to be installed with a recirculation circuit with an internal pump (see Figure 4-6), you must:

- 1.- Set up the hydraulic installation as shown in Figure 4-6;
- 2.- Respect the pressure output curve shown in the form of a graph in the Figure (see Figure 5-11);
- 3.- Set parameter **0003** = OFF;
- 4.- Set parameter **2035** = 7;
- 5.- Set parameter **2064** = 3;
- 6.- Connect a timer with a free contact that sets the turning on and off of the recirculation to terminals "14" and "15" in Figure 5-10.

☞ The recirculation circuit starts up only after domestic hot water has been drawn off at least twice, to be sure that the system has been loaded with water.

Key for Figure 5-11

A = Aguadens 16 and 22

B = Aguadens 37

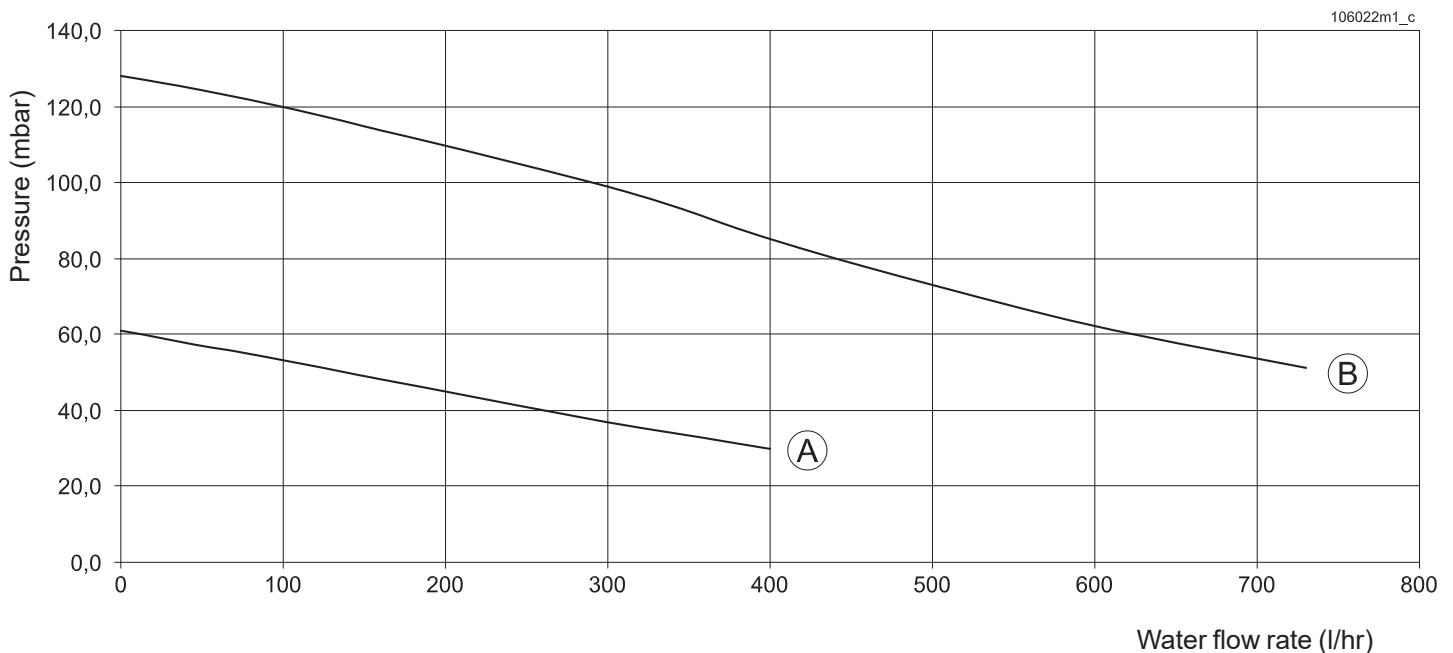

Figure 5-11 - Residual head of recirculation circuit with internal pump curve

5 - INSTALLATION

5.14 - Connection of hot water heater to storage tank

Proceed as follows for the electric connections (refer to Figure 5-10):

- 1.- Disconnect the electric power supply from the appliance;
- 2.- Disconnect the connector from probe n°46 in Figure 3-1 or 3-3;
- 3.- Lay a two-pole electric cable with a minimum cross-section of 1.5 mm², which goes from the appliance to the storage tank temperature sensor and connect it to the boiler on clamps "8" and "9" (SB);
- 4.- Connect the other end of the cable to the storage tank temperature sensor;
- 5.- Insert the temperature sensor probe inside the storage tank sample point (see Figure 5-12, detail "8");
- 6.- Connect the storage tank pump power supply to terminals "EP" of the hot water heater;
- 7.- set parameters $2035 = 1$ and $2038 = 10$;
- 8.- set parameter $2117 = 3$;
- 9.- set parameters 2140 and 2141 at the value of 0,7 (7 l/min) for Aguadens 16-22 and 1,5 (15 l/min) for Aguadens 37. In this way, if the water flow rate between the water heater and the storage tank is lower than these values, the water heater generates a "low water flow" error.

The temperature of the water stored inside the storage tank can be selected by the user from a range of between 40°C and 75°C.

The factory sets the maximum temperature that can be selected at 60°C. To increase this to 80°C use parameter

2091 and set it at 80.



WARNING! If the temperature rises above 60°C, the hardness of the water must be reduced to 15°F.



WARNING! A hot water temperature exceeding 51°C may cause permanent injury/damage to persons, animals and objects.

In particular, protect children, the elderly and people with disabilities against any possible risks of scalds, by inserting devices that limit the usage temperature of the DHW to users.



WARNING! On first ignition bleed all the air present in the system. Make sure that there is a water flow of at least 10 l/min between the hot water heater and the storage tank, which can be controlled at

parameter 1062 . If the water flow rate is lower, the appliance won't work.

5.14.1 - Anti-legionella

If the boiler is connected to a storage tank for the preparation of domestic hot water, a disinfection cycle is used against legionella bacteria. This cycle involves bringing the storage tank to 60°C (temperature at which the legionella bacteria dies), two hours after the appliance was connected to the power supply and at least every week. For this reason the water (at some times) may reach users at a higher temperature than that set with the relevant command.



WARNING !!! If the appliance is connected in cascade, as provided at Section 5.15, the anti-legionella cycle is not enabled. It is therefore necessary to take all precautions to avoid the proliferation of legionellosis, which to keep the delivery temperature of the cascade at a temperature not lower than 60°C.

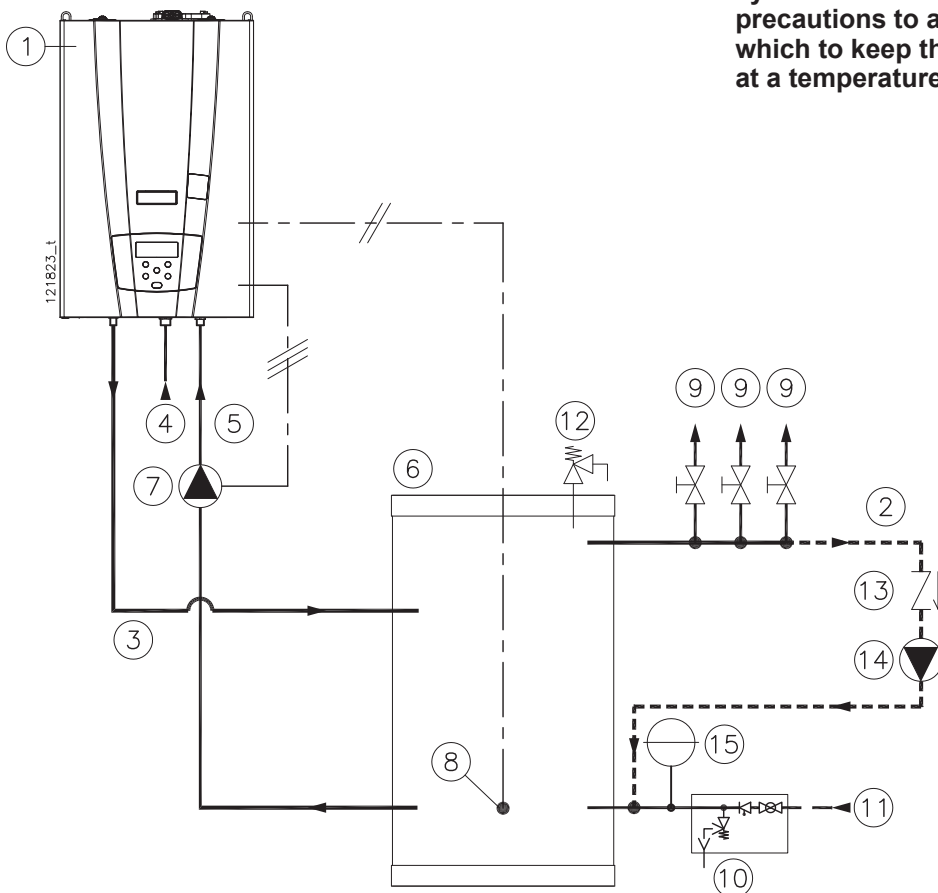

KEY

- 1 Hot water heater
- 2 Recirculation (where present) *
- 3 Domestic hot water outlet
- 4 Gas inlet
- 5 Cold water
- 6 Storage tank
- 7 Storage tank loading pump
- 8 Storage tank probe
- 9 DHW uses
- 10 Hydraulic safety unit (responsibility of installer)
- 11 Cold water inlet
- 12 Some circumstances require the installation of this temperature and pressure safety valve in the storage tank
- 13 Check valve
- 14 Recirculation pump (where present)
- 15 Expansion tank

* The recirculation line is not compulsory.

Figure 5-12 – Hydraulic connection to storage tank

5 - INSTALLATION

5.15 - Cascade appliances connection

5.15.1.- Cascade appliances connection

This appliance can be connected in cascade up to a maximum of 8 units. The hydraulic connection diagram is shown in Figure 5-14. It is possible to perform other types of hydraulic connections (ask the manufacturer for the reference diagrams). The cascade is managed by the motherboard of the appliance that we will define here and then "Manager".

To connect the appliances in cascade, proceed as follows:

- 1.- Make sure the recirculation circuit has a flow rate of at least 600 l/h (properly size the recirculation circuit and its pump);
- 2.- Perform the hydraulic installation as shown in Figure 5-14;
- 3.- Perform the electrical installation as shown in Figure 5-13;
- 4.- Access the appliance where the cascade sensor has been connected and that will be the one closest to the general supply and set the following parameters:
 - 0911 = 4 ("Manager" device unit display shows the cascade temperature);
 - 2001 = 0 (constant setpoint);
 - 2035 = 0 (DHW service switched off);
 - 2117 = 3 (swater flow meter on the heat exchanger);
 - 2128 = 18 (diverter valve in DHW when in stand-by);
 - 2141 = to the following values: 1 for models "16" and "22"; 2,8 for models "37" (maximum water flow rate);
 - 4184 = 1 (logical address of the communication bus);
 - 4147 = value corresponding to the total number of devices installed in the cascade ("Manager" included);

5.- Remaining on the "Manager" device, check that the "S4" Switch is in the ON position (See Figure 5-13);

6.- Access the next device that will become the first "Dependent" and set the following parameters:

- 2001 = 0 (constant setpoint);
- 2035 = 0 (DHW service switched off);
- 2117 = 3 (swater flow meter on the heat exchanger);
- 2141 = to the following values: 1 for models "16" and "22"; 2,8 for models "37" (maximum water flow rate);
- 4184 = 2 (logical address of the communication bus).

7.- Remaining on the "Dependent" device, move the "S4" Switch in the OFF position (See Figure 5-13);

8.- Access the next appliances and for each one, repeat the instructions of point 6 and of the previous point 7, considering that the parameter 4184 must be increased by one unit for each additional device.

☞ When the "Dependent" device is correctly connected to the "Manager", the radiator symbol disappears from the display.

☞ The cascade set point temperature must be set with parameter 0003 (see Section 7.6) and at a temperature of 15 °C higher than the mixing valve set point.

☞ If "Manager" unit switch off or loose the bus communication, "Dependent" units will go in stand-by.

☞ If "Manager" unit miss one "Dependent", "AL E 200" will be shown on the "Manager" display (See Section 7.8).

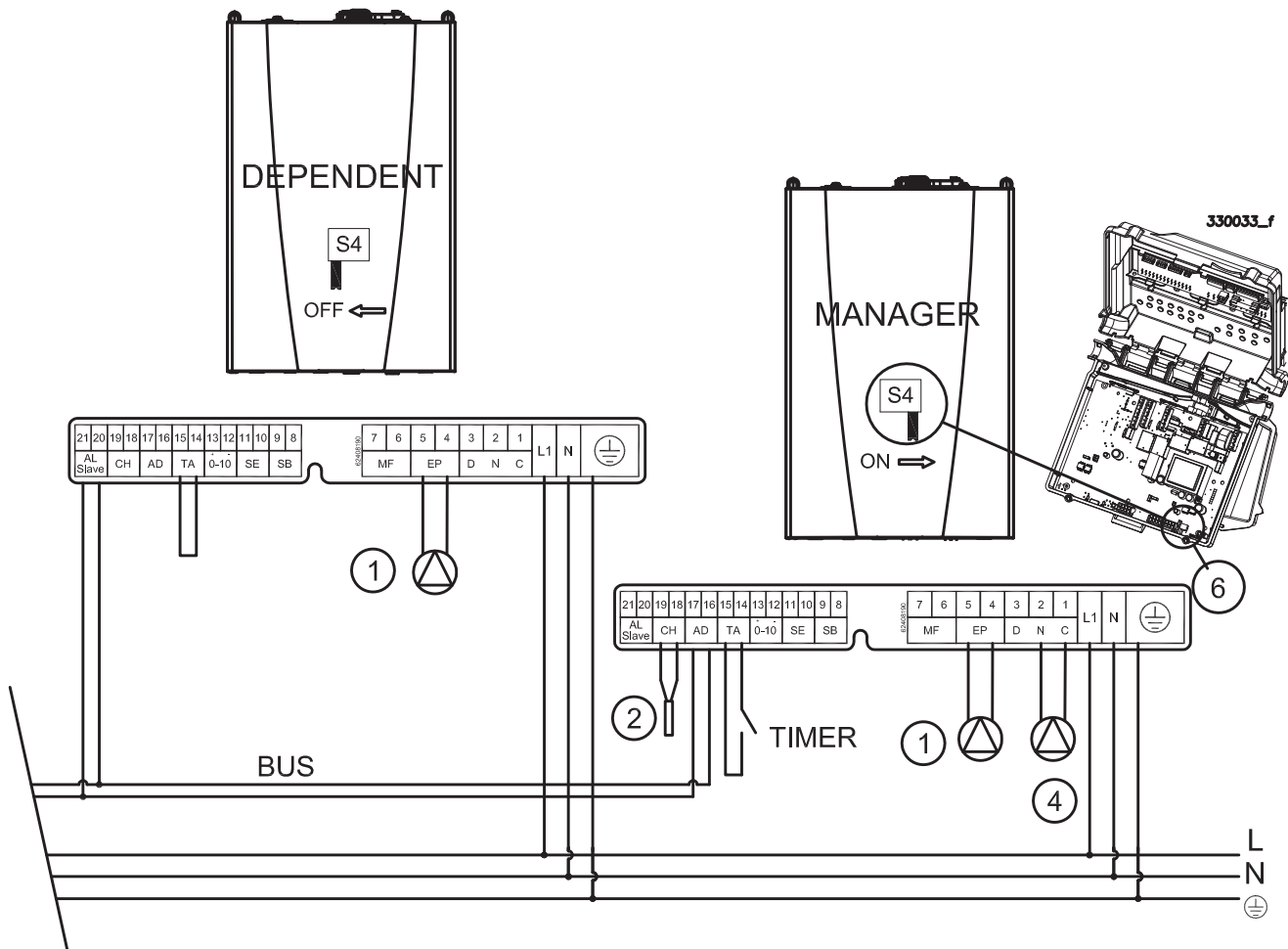

Figure 5-13 - Electrical connection of appliances in cascade without storage tank

5 - INSTALLATION



Figura 5-14 - Hydraulic connection of appliances in cascade without storage tank

5 - INSTALLATION

5.15.2.- Cascade appliances connection with storage tank

WARNING!!! The system does not perform the anti-legionella cycle so it is mandatory to keep the temperature of the storage tank at least 60 ° C.

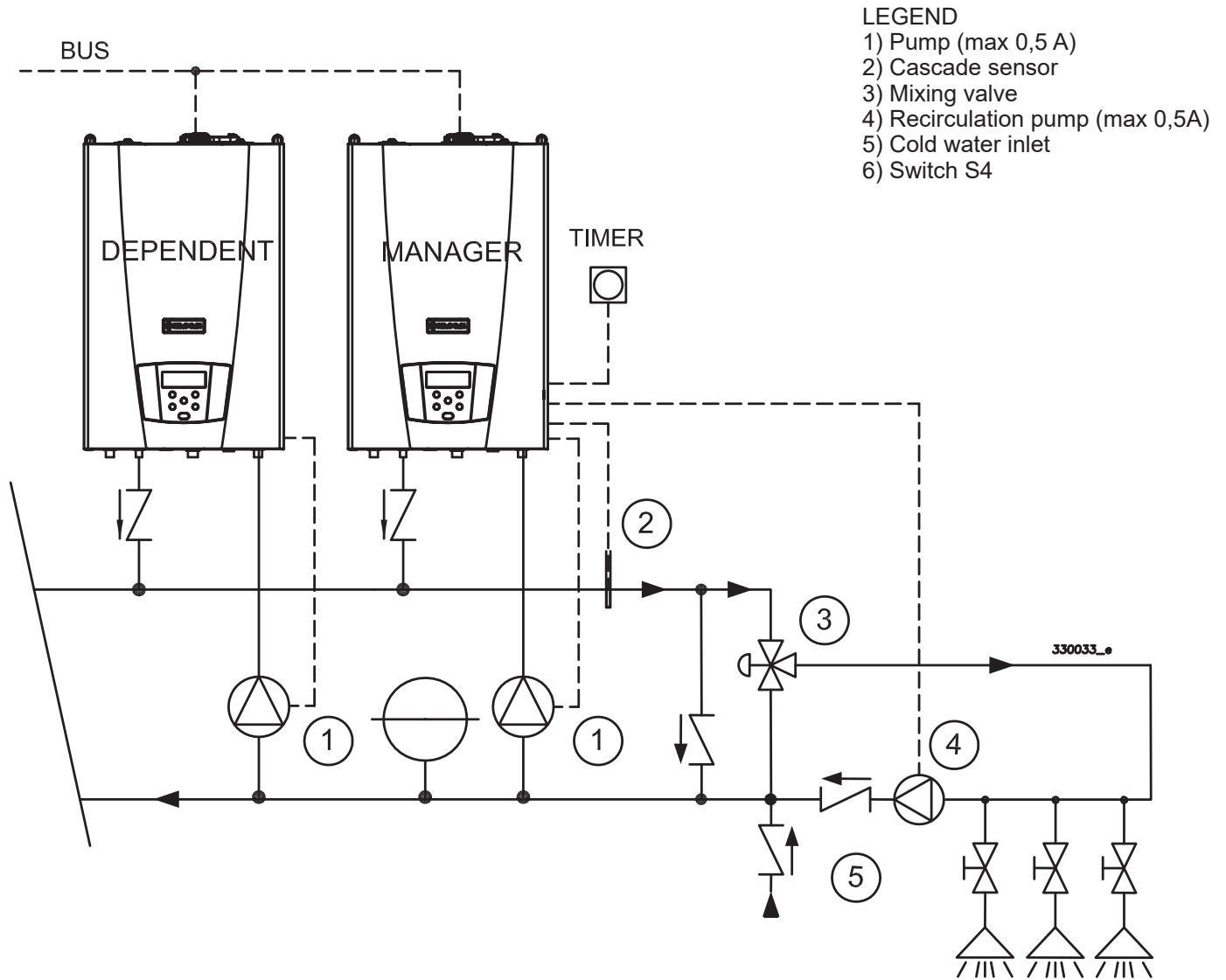
This appliance can be connected in cascade up to a maximum of 8 units. The hydraulic connection diagram is shown in Figure 5-16. It is possible to perform other types of hydraulic connections (ask the manufacturer for the reference diagrams). The cascade is managed by the motherboard of the appliance that we will define here and then "Manager".

To connect the appliances in cascade, proceed as follows:

- 1.- Perform the hydraulic installation as shown in Figure 5-16;
- 2.- Perform the electrical installation as shown in Figure 5-15;
- 3.- Access the appliance where the cascade sensor has been connected and that will be the one closest to the general supply and set the following parameters:

- 0911 = 4 ("Manager" device unit display shows the cascade temperature);
- 2001 = 0 (constant setpoint);
- 2035 = 0 (DHW service switched off);
- 2117 = 3 (water flow meter on the heat exchanger);
- 2141 = to the follow values: 1 for models "16" and "22"; 2,8 for models "37" (maximum flow rate);
- 4184 = 1 (logical address of the communication bus);
- 4147 = is the value corresponding to the total number of appliances in the cascade ("Manager" included).

- 4.- Remaining on the "Manager" device, check that the "S4" Switch is in the ON position (See Figure 5-15);
- 6.- Access the next device that will become the first "Dependent" and set the following parameters:
 - 2001 = 0 (constant setpoint);
 - 2035 = 0 (DHW service switched off);
 - 2117 = 3 (water flow meter on the heat exchanger);
 - 2141 = to the follow values: 1 for models "16" and "22"; 2,8 for models "37" (maximum flow rate);
 - 4184 = 2 (logical address of the communication bus).
- 6.- Remaining on the "Dependent" device, move the "S4" Switch in the OFF position (See Figure 5-15);
- 7.- Access the next appliances and for each one, repeat the instructions of point 5 and of the previous point 6, considering that the parameter 4184 must be increased by one unit for each additional device.

- ☞ When the "Dependent" device is correctly connected to the "Manager", the radiator symbol disappears from the display.
- ☞ The cascade set point temperature must be set with parameter 0003 (see Section 7.6) and at a temperature of 15 °C higher than the mixing valve set point.
- ☞ If "Manager" unit switch off or loose the bus communication, "Dependent" units will go in stand-by.
- ☞ If "Manager" unit miss one "Dependent", "ALTE 200" will be shown on the "Manager" display (See Section 7.8).



Figura 5-15 - Electrical connection of appliances in cascade with storage tank

5 - INSTALLATION



Figura 5-16 - Hydraulic connection of appliances in cascade with storage tank

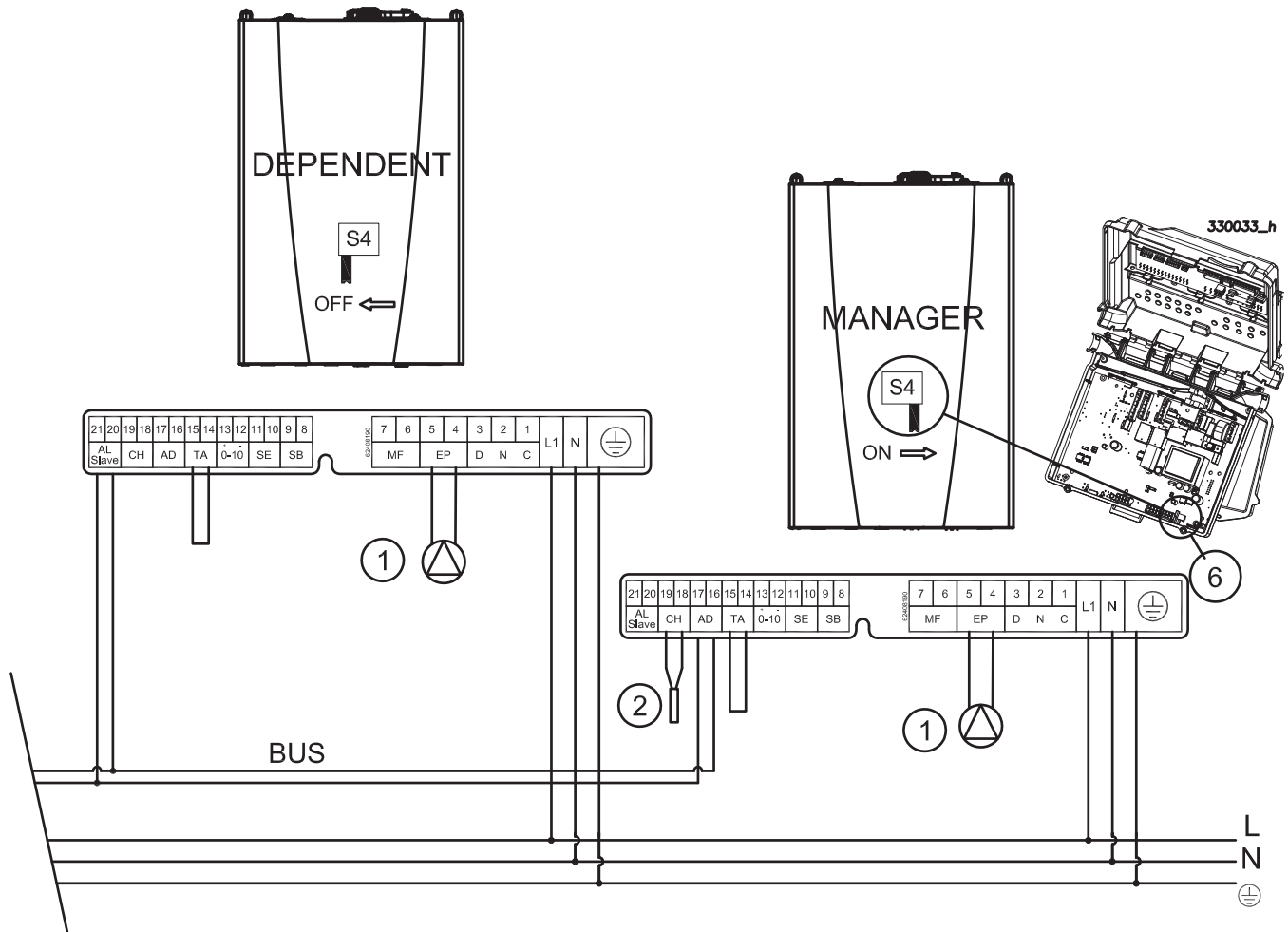

5.16 - Burned gas exhaust and combustion agent air intake pipe

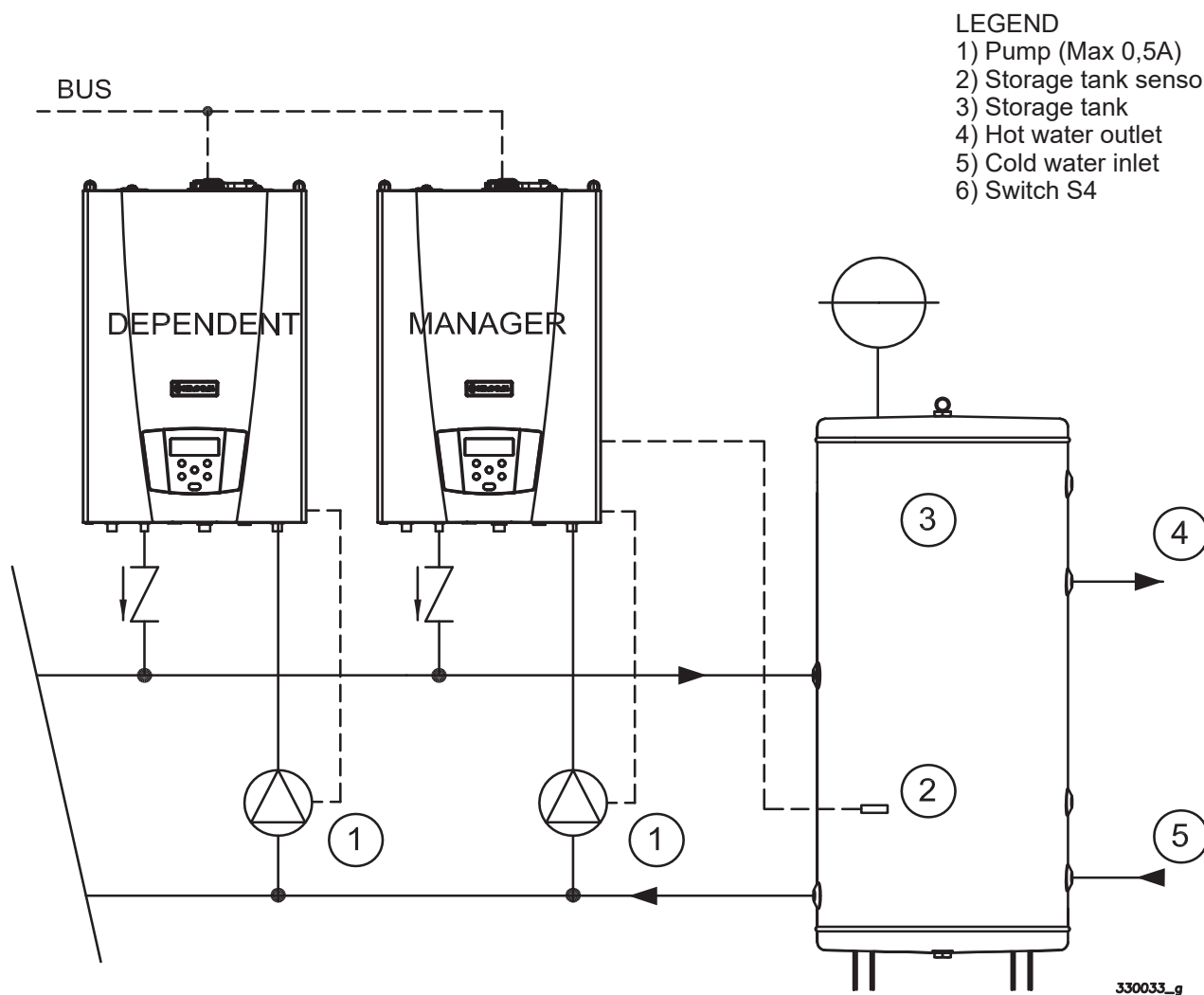
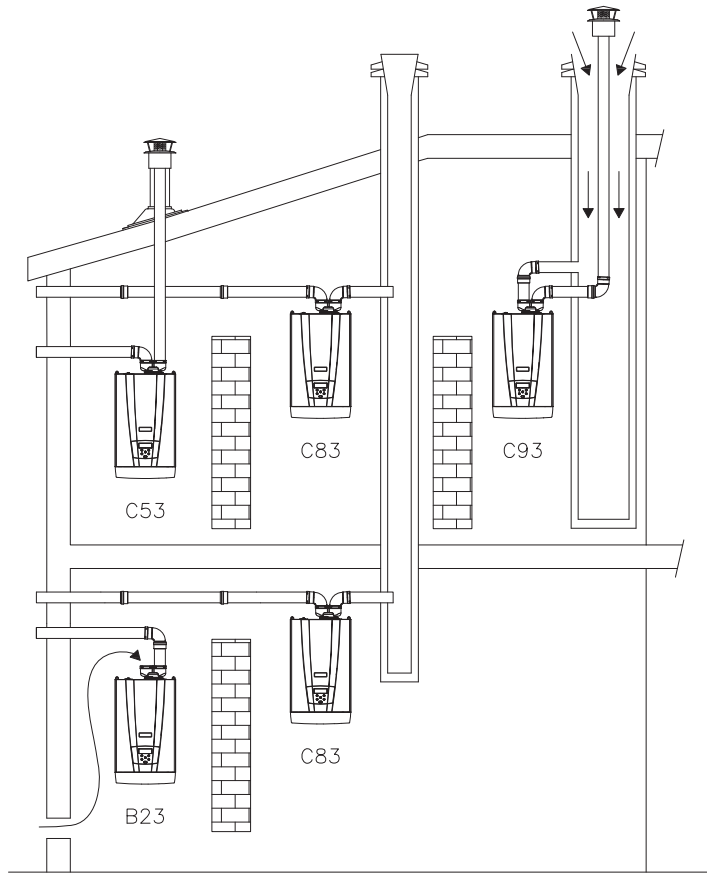

WARNING! To connect the burned gas exhaust and combustion agent air intake, the relevant national and local regulations must be respected.



WARNING! The flue gas from this appliance can reach 90°C in certain conditions. Therefore, use pipes made of plastic that can resist high temperatures.



WARNING! This appliance is a “condensing” boiler. Use AISI 316L stainless steel materials or polypropylene plastic materials to make the flue gas exhaust so as to prevent corrosion due to the acidity of the condensate.

Please remember that appliances of this type must have exhaust and intake pipes supplied by the manufacturer of the appliance itself. Other types of pipes, if used, must be type-approved for this intended use.

The types of exhaust for which the appliance is approved are given in the technical features table at the end of the manual under the “type” heading and on the data plate on the boiler, also under the “type” heading.

The symbols used to define the type of exhaust are given below:

- B23 and B23P, separated with intake in room and exhaust through wall or roof;



WARNING! If the appliance is installed with a B23 or B23P exhaust, it will take in air for combustion from the surrounding environment. Therefore, all precautions must be taken regarding ventilation of the rooms as prescribed by the national and/or local regulations.

- C13, coaxial in vertical wall;

- C33, coaxial at the roof;

- C43, separated with exhaust in flue, combined with intake in common channel;



WARNING! The appliances installed in type C43 must only be connected to natural-draught flues.

- C53, separated with exhaust on roof and intake on wall, or in two potentially different pressure points;



WARNING! With installation type C53, the flue exhaust and air intake terminals cannot be installed on opposite walls of the building.

- C63, the appliance can be fitted to type-approved exhaust and intake pipes made by other brands;



WARNING! With C63 exhausts, the condensate coming from the chimney cannot be conveyed into the appliance.

- C83, separated with wall intake or another point independent from the intakes of other appliances, and flue exhaust;

- C93, separated with exhaust on roof and intake in pre-existing channel.

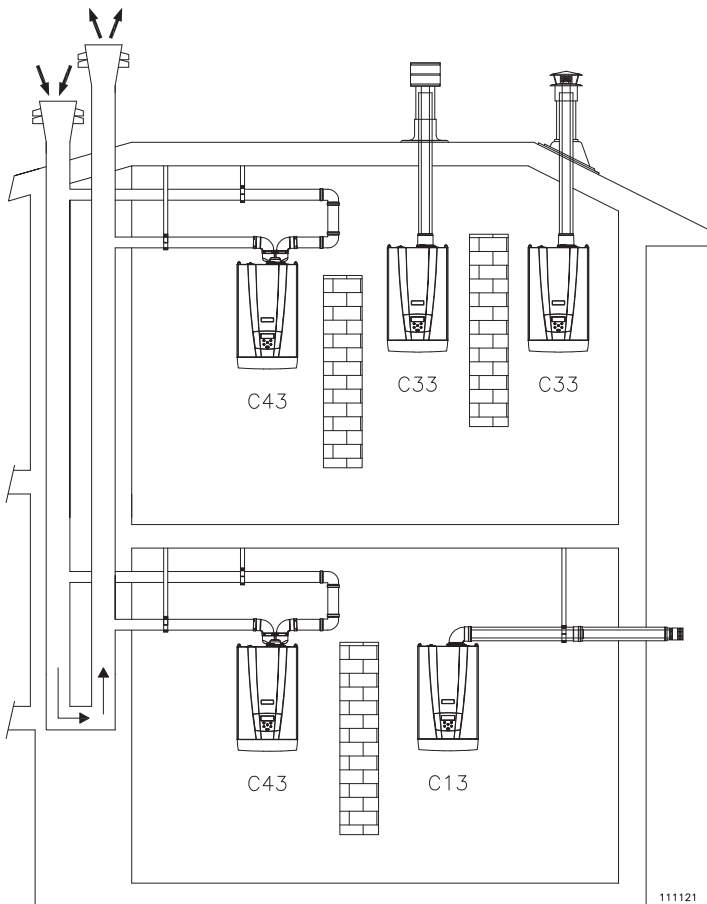

Figure 5-17 – Exhaust/intake systems

5 - INSTALLATION

During operation, especially in winter, it is possible that white smoke may emerge from the boiler's flue gas outlet because of its high efficiency. This is a natural phenomenon and is not a cause for concern. It is the water vapour in the flue gas which condenses when it comes into contact with the outside air.

5.16.1 - Type of intake/exhaust B23 and B23P

In the case of B23 and B23P type combustion agent air intake/flue gas exhaust systems, it is essential that the rooms in which the appliances are installed have at least as much air as is required for combustion and ventilation of the room. It is therefore useful to remember that the combustion of 1 m³ of gas requires 11 m³ of air.

The natural flow of air must take place directly through permanent openings made in the outside walls of the room to be ventilated. However, these must be away from sources of pollution, such as vents of dubious origin, airborne industrial exhausts, etc.

The ventilation openings must meet the following requirements:

- ☞ Have cross-sections with net passage of at least 6 cm² for every kW of heat input installed, with minimum of 100 cm².
- ☞ Be constructed in such a way that the opening inlets both inside and outside the wall cannot be blocked.
- ☞ Be protected, for example with grids, mesh, etc. The net passage cross-section must not be reduced by these systems.
- ☞ Be positioned at a height near to floor level and in such a way as not to cause any problems with the operation of the combustion product exhaust devices; where this position is not possible, the cross-section of the ventilation openings must be increased by at least 50%.

The air flow can also be obtained from an adjoining room provided that:

- ☞ It has direct ventilation, in compliance with the points above.
- ☞ Only this gas appliance is installed in the room to be ventilated.
- ☞ The adjacent room is not a bedroom.
- ☞ The adjacent room is not a communal part of the building.
- ☞ The adjacent room is not an environment with fire hazards such a hangar, garage, warehouse for combustible materials, etc.
- ☞ The adjacent room does not have a negative pressure with respect to the room to be ventilated due to reverse draught (which can be caused by another appliance operating with any type of fuel in the same room, or a fireplace or any other intake device for which an adequate air intake has not been provided for).
- ☞ The flow of air from the adjacent room to the room to be ventilated can take place freely through permanent openings, with a total net cross-section not less than that indicated at the start of this section.

In rooms where gas appliances are installed, it may become necessary to evacuate stale air, as well as introducing combustion agent air, the result being the release of an additional equal amount of clean air.

If the stale air is evacuated with the aid of a mechanical tool (electric fan), the following conditions must be respected:

- a) if there is a common exhaust pipe in the room that is not in service, it must be capped;
- b) the ventilation opening in the room in which the gas appliance is installed must be increased, depending on the maximum air flow rate required at the electric fan.
- c) the action of the electric fan must not affect the correct evacuation of the combustion products. Check all of the above by running a draught test. Run the fan or extractor hood at its maximum power and the gas appliance at the maximum and minimum power.

5.16.2 - "Split 80/80PP" system (polypropylene) (type C43; C53; C83; C93) AGUADENS 16 and 22

The appliance is supplied as per standard without fittings to connect the flue gas exhaust/air intake. To connect it to a "Split 80/80PP" system, the relevant kit must be requested and must be installed as in Figure 5-18.

Fitting "A" can rotate freely through 360°, guaranteeing optimum installation versatility.

In the flue gas exhaust side, it is recommended to install AISI 316L stainless steel or polypropylene pipes, which are more resistant to the formation of condensate.

Take particular care with the installation of pipes in the part that goes through the wall to the outside. Normal maintenance operations must always be possible; therefore, install the pipes in a sheath so that they can be slid out.

The horizontal tracts must always have an inclination of at least 2% towards the condensate drain device.

The boiler is already equipped with a condensate collector, which must be fitted to a drain pipe (see Section 5.7).



WARNING! This condensate drain is designed to drain away all of the liquid produced by a single appliance. If more than one boiler is installed, each boiler should have its own condensate drain.

The flue gas exhaust/air intake system can be extended up to a maximum distance as indicated in Section 9. Every 90° bend has a loss equivalent to the value in Section 9. Every 45° bend has a loss equivalent to the value in Section 9.



WARNING! The flue gas exhaust terminal must be appropriately protected against the effects of the wind (see also Section 7.8.1 error L 0 C 2 2).



WARNING! Mechanically secure the joints between the various component elements of the exhaust and intake pipe, through the use of fixing systems or equivalent systems. See Figure 5-20.



WARNING! The temperature of the exhaust pipe can reach 90°C during operation. If the pipe passes through walls that are sensitive to these temperatures, insert a protective heat-insulating sheath.



WARNING! If the air intake and flue gas exhaust terminals are positioned on the same wall, they must remain at a minimum distance of 1 metre.



WARNING! The exhaust and intake pipes must be appropriately sustained via rigid brackets positioned no more than 1 metre from each other. The brackets must be fixed to rigid walls that can support the weight of the pipe itself.

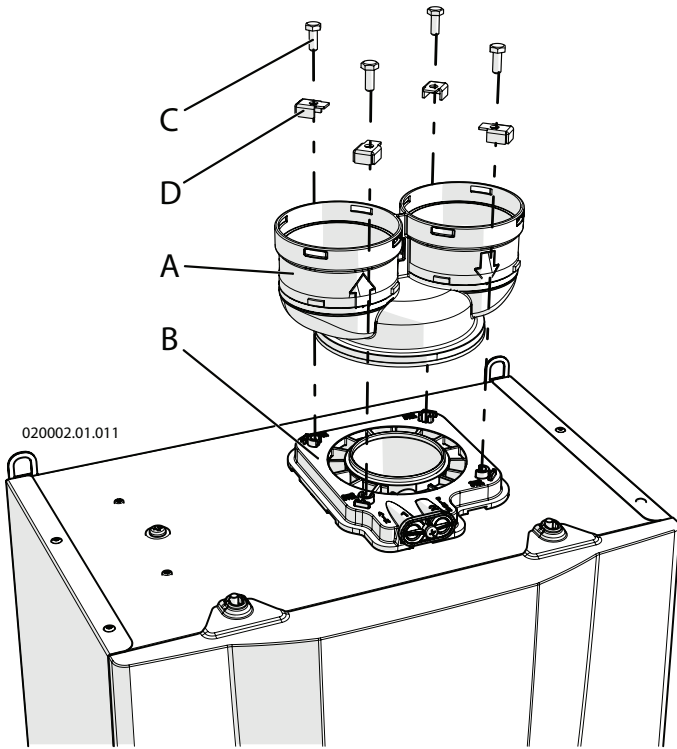

Figure 5-18 – Installing the "Split 80/80PP" system

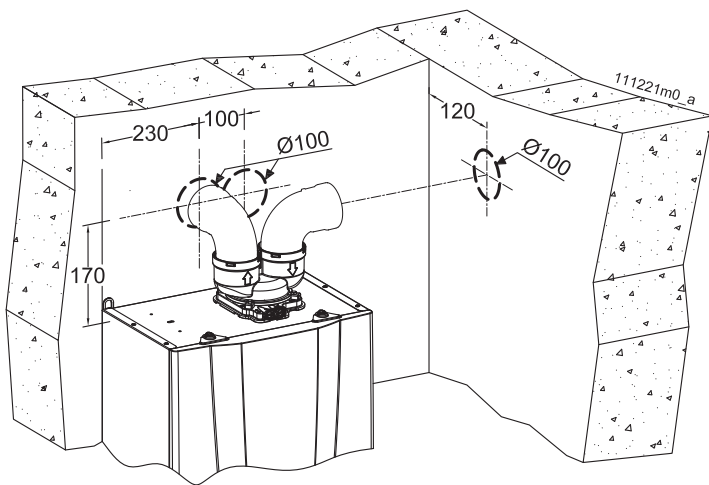

Figure 5-19 - Overall dimensions

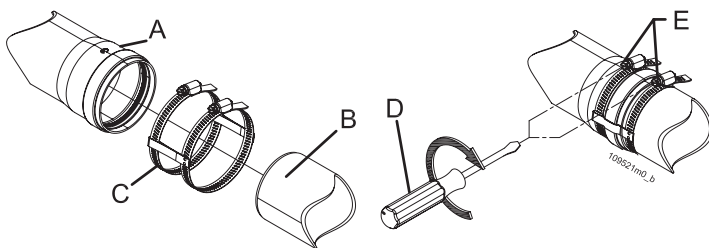

Figure 5-20 – Fixing the exhaust and intake pipes

5.16.3 - "Split 80/80PP" system (polypropylene) (type C43; C53; C83; C93) AGUADENS 37

The appliance is supplied as per standard without fittings to connect the flue gas exhaust/air intake. To connect it to a "Split 80/80PP" system, the relevant kit must be requested and must be installed as in Figure 5-21.

Fitting "A" can rotate freely through 360°, guaranteeing optimum installation versatility.

In the flue gas exhaust side, it is recommended to install AISI 316L stainless steel or polypropylene pipes, which are more resistant to the formation of condensate.

Take particular care with the installation of pipes in the part that goes through the wall to the outside. Normal maintenance operations must always be possible; therefore, install the pipes in a sheath so that they can be slid out.

The horizontal tracts must always have an inclination of at least 2% towards the condensate drain device.

The boiler is already equipped with a condensate collector, which must be fitted to a drain pipe (see Section 5.7).



WARNING! This condensate drain is designed to drain away all of the liquid produced by a single appliance. If more than one boiler is installed, each boiler should have its own condensate drain.

The flue gas exhaust/air intake system can be extended up to a maximum distance as indicated in Section 9. Every 90° bend has a loss equivalent to the value in Section 9. Every 45° bend has a loss equivalent to the value in Section 9.



WARNING! The flue gas exhaust terminal must be appropriately protected against the effects of the wind (see also Section 7.8.1 error L O C 22).



WARNING! Mechanically secure the joints between the various component elements of the exhaust and intake pipe, through the use of fixing systems or equivalent systems (See Figure 5-23)



WARNING! The temperature of the exhaust pipe can reach 90°C during operation. If the pipe passes through walls that are sensitive to these temperatures, insert a protective heat-insulating sheath.



WARNING! If the air intake and flue gas exhaust terminals are positioned on the same wall, they must remain at a minimum distance of 1 metre.



WARNING! The exhaust and intake pipes must be appropriately sustained via rigid brackets positioned no more than 1 metre from each other. The brackets must be fixed to rigid walls that can support the weight of the pipe itself.

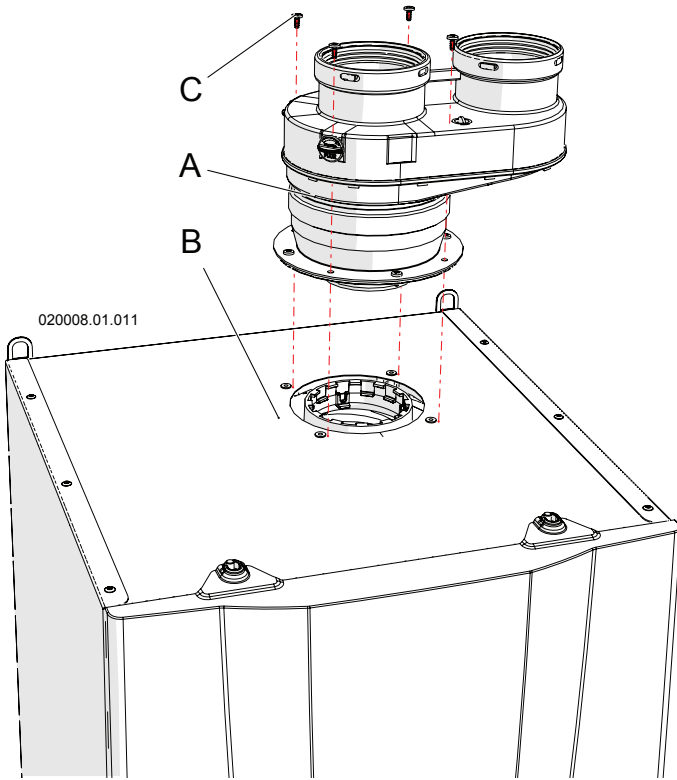

Figure 5-21 – Installing the "Split 80/80PP" system

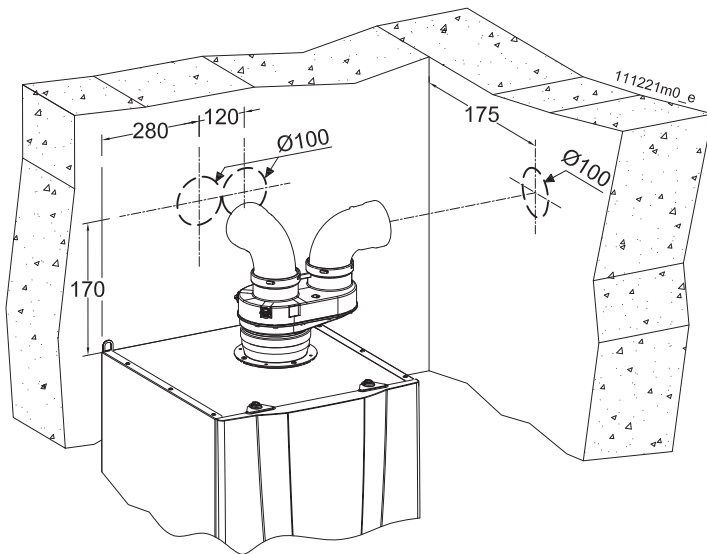

Figure 5-22 - Overall dimensions

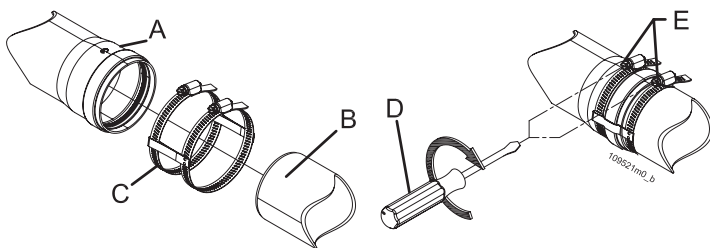

Figure 5-23 – Fixing the exhaust and intake pipes

5.16.4 - "Split 80/80PP" system (type C43; C53; C83; C93): accessories available

To make the "80/80PP split" flue gas exhaust/air intake system, we offer some of the most common accessories available; remember that a wide range can be found in the relevant catalogue:

(the number after the code refers to the piece in the diagrams that follow)

62617306 - N° 10 PP roof terminal

62617244 - N° 12 M/F PP 90° bend

62617255 - N° 29 valley for pitched roofs from 15° up to 25°

62617236 - N° 11 M/F PP extension

62617249 - N° 18 PP anti-slip bands for extensions

62617240 - N° 14 M.F. PP L=20m hose

62617241 - N° 16 spacer for hose

62617238 - N° 17 PP telescopic joint

62617242 - N° 15 PP T-fitting

62617246 - N° 13 M/F PP 45° bend

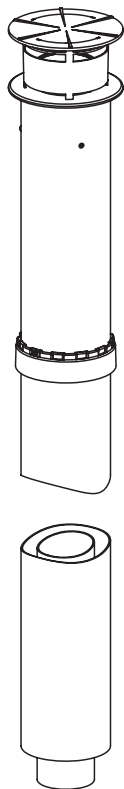

62617306

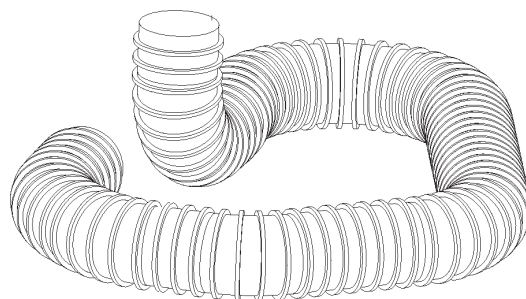

62617240

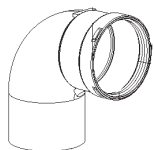

62617244

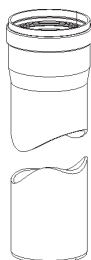

62617236

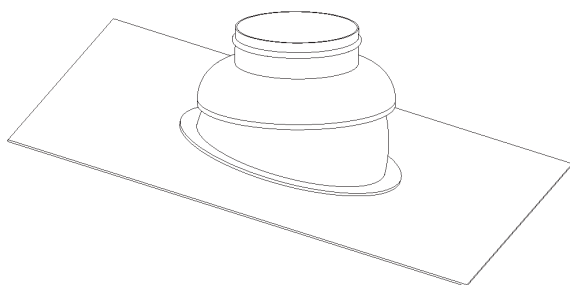

62617255



62617238

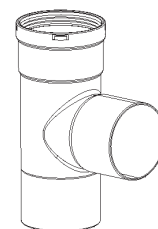

62617242



62617246

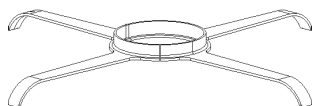

62617241

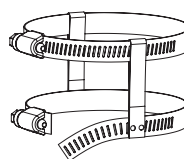

62617249

5.16.5 - "Split 80/80PP" system (type C43; C53; C83; C93): installation examples

In Figure 5-24 two installation examples are given:

- exhaust in chimney with condensate collection inside the boiler itself.

The horizontal part of the flue gas exhaust side must be inclined towards the boiler.

The intake must slope towards the outside to prevent rain water entering.

- exhaust on the outside, directly via the boiler pipes with condensate collection inside the boiler itself.

The intake must slope towards the outside to prevent rain water entering.

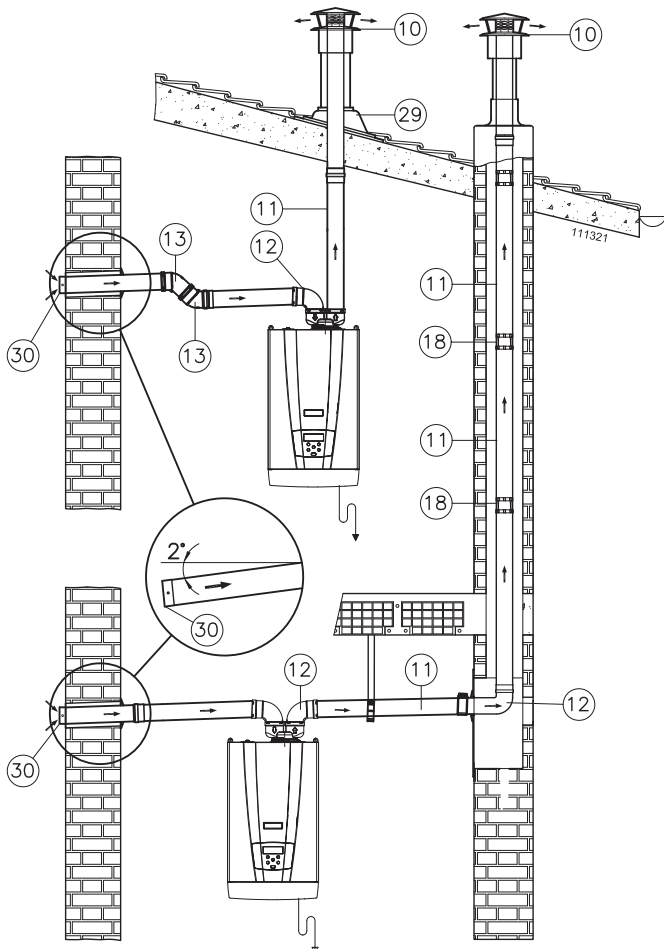

Figure 5-24 – Example of "80/80 PP system" installation

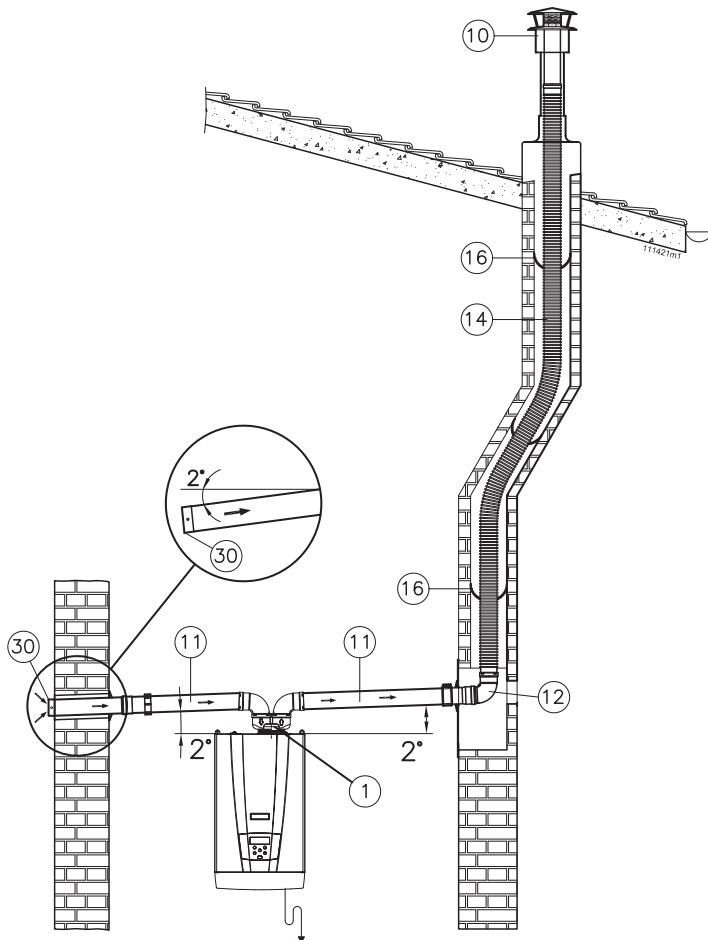

Figure 5-25 – Example of "80/80 PP system" installation

See Figure 5-25 for a separate flue gas exhaust set-up, where the exhaust is made from a polypropylene hose for ducting the technical cells.

The condensate produced in the vertical pipe must all be conveyed into the boiler.

The intake must slope towards the outside to prevent rain water entering.

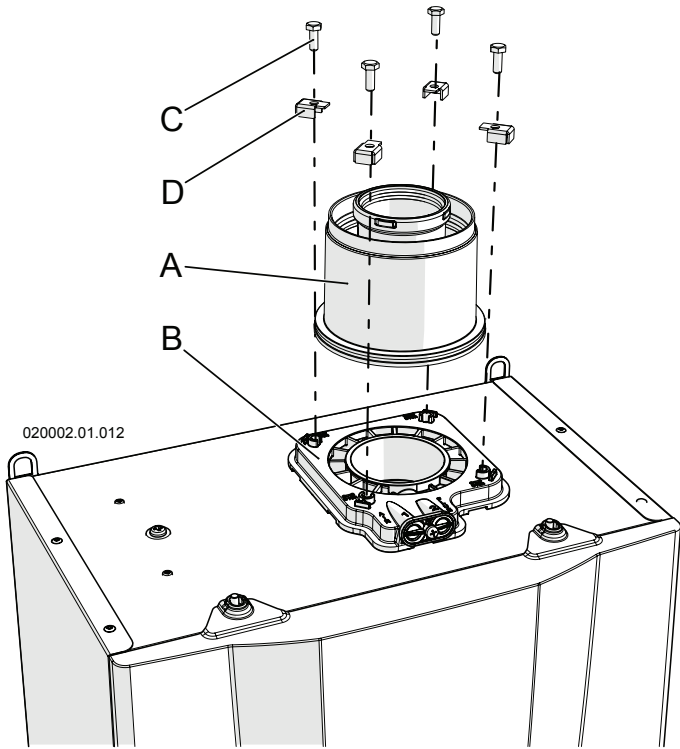

Figure 5-26 – Installation of vertical coaxial system

5.16.6 - “60/100PP vertical coaxial” system (polypropylene) (type C13; C33) AGUADENS 16 and 22

The appliance is supplied as per standard without fittings to connect the flue gas exhaust/air intake. To connect the boiler to a 60/100 vertical coaxial system, the relevant kit must be requested and must be installed as in Figure 5-26.



WARNING! Scrupulously follow the coaxial pipe installation phases as illustrated in Figure 5-28. In particular:

- 1.- Insert coaxial pipe “C” into bend “A”;
- 2.- Fix the external pipe using the stainless steel self-threading screws “B”.



WARNING! The coaxial exhaust and intake pipes must be appropriately sustained via rigid brackets positioned no more than 1 metre from each other. The brackets must be fixed to rigid walls that can support the weight of the pipe itself.



WARNING! Once these operations have been performed, check that the exhaust/intake terminal is exposed to the outdoors with the tolerances given in Figure 5-32.

☞ Take particular care with the installation of pipes in the part that goes through the wall to the outside. Normal maintenance operations must always be possible; therefore, install the pipes in a sheath so that they can be slid out.

☞ The horizontal tracts must always have an inclination of at least 2% towards the boiler.

☞ The flue gas exhaust/air intake pipe can be extended up to the maximum distance indicated in the table in Section 9 at the end of the manual. Every 90° bend has a loss equivalent to the value in Section 9. Every 45° bend has a loss equivalent to the value in Section 9.

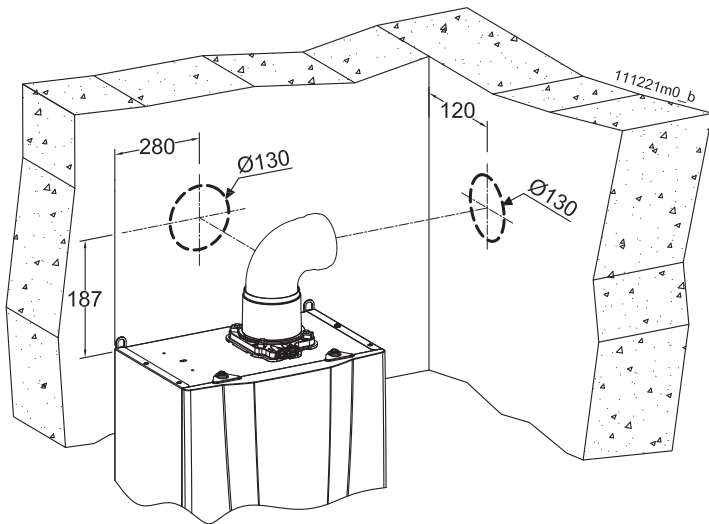

Figure 5-27 - Measurements and centre space distances for coaxial exhaust preinstallation hole

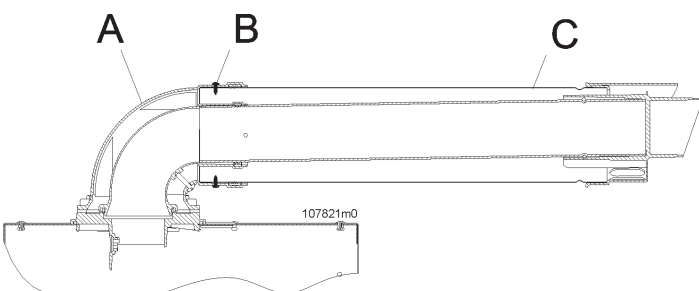

Figure 5-28 - Positioning the coaxial pipe

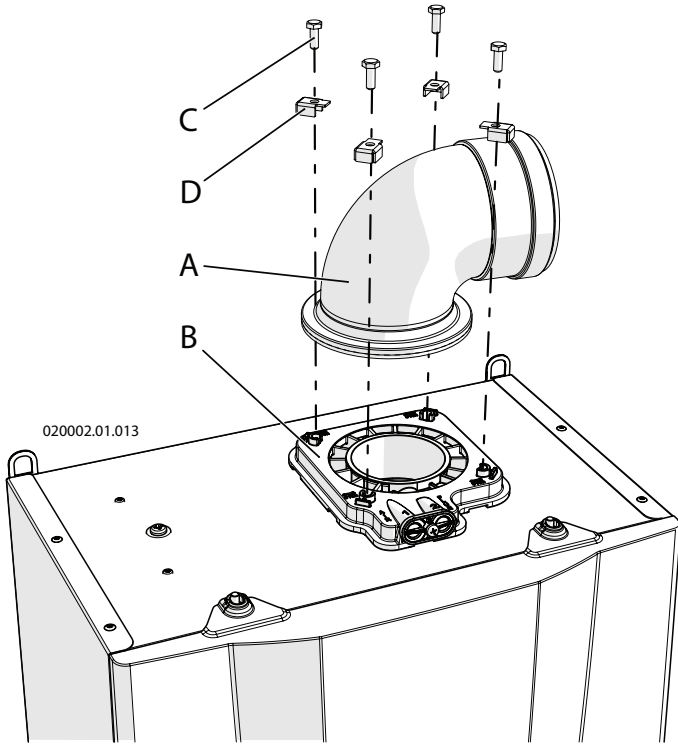

Figure 5-29 – Installing the horizontal coaxial system

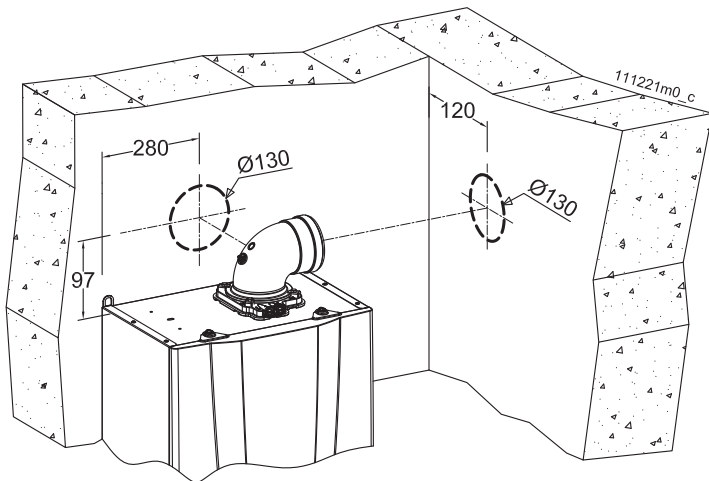

Figure 5-30 - Measurements and centre space distances for coaxial exhaust preinstallation hole

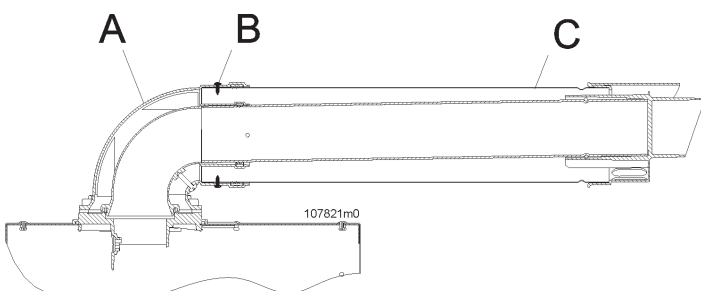

Figure 5-31 - Positioning the coaxial pipe

5.16.7 - “60/100PP horizontal coaxial” system (polypropylene) (type C13; C33) AGUADENS 16 and 22

The appliance is supplied as per standard without fittings to connect the flue gas exhaust/air intake. To connect the appliance to a 60/100 coaxial system, the relevant kit must be requested and must be installed as in Figure 5-29.



WARNING! Scrupulously follow the coaxial pipe installation phases as illustrated in Figure 5-31. In particular:

- 1.- Insert coaxial pipe “C” into bend “A”;
- 2.- Fix the external pipe using the stainless steel self-threading screws “B”.



WARNING! The coaxial exhaust and intake pipes must be appropriately sustained via rigid brackets positioned no more than 1 metre from each other. The brackets must be fixed to rigid walls that can support the weight of the pipe itself.



WARNING! Once these operations have been performed, check that the exhaust/intake terminal is exposed to the outdoors with the tolerances given in Figure 5-32.

☞ Take particular care with the installation of pipes in the part that goes through the wall to the outside. Normal maintenance operations must always be possible; therefore, install the pipes in a sheath so that they can be slid out.

☞ The horizontal tracts must always have an inclination of at least 2% towards the boiler.

☞ The flue gas exhaust/air intake pipe can be extended up to the maximum distance indicated in the table in Section 9 at the end of the manual. Every 90° bend has a loss equivalent to the value in Section 9. Every 45° bend has a loss equivalent to the value in Section 9.

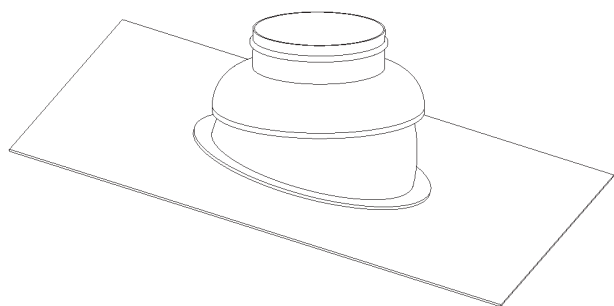

62617255

5.16.8 - "60/100PP coaxial" system: accessories available

The following accessories are available on request to make the 60/100 coaxial flue gas exhaust/air intake system: (the number after the code refers to the piece in the diagrams that follow)

62617255 - N° 2 valley for pitched roofs from 5° to 25°
extension L = 1000 mm

62617234 - N° 1 M/F PP 90° coaxial bend

62617252 - N° 6 M/F PP 45° coaxial bend

62617231 - N° 7 L 1m PP coaxial extension

62617304 - N° 3 PP coaxial roof terminal

62617232 - N° 5 PP coaxial wall terminal

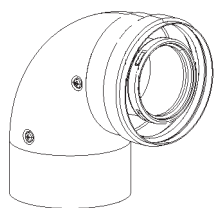

62617234

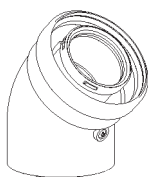

62617252

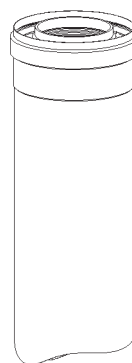

62617231

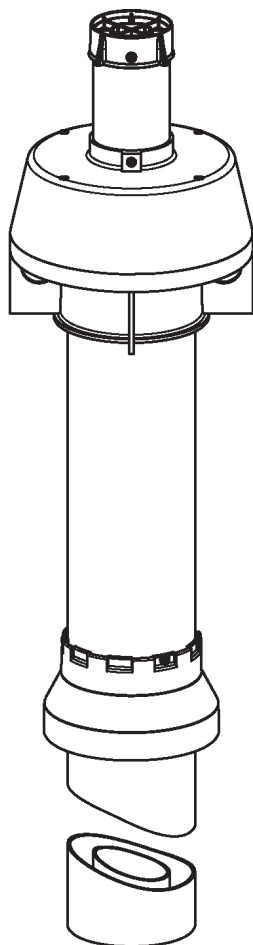
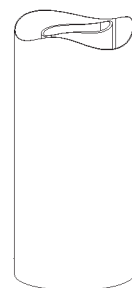

62617304

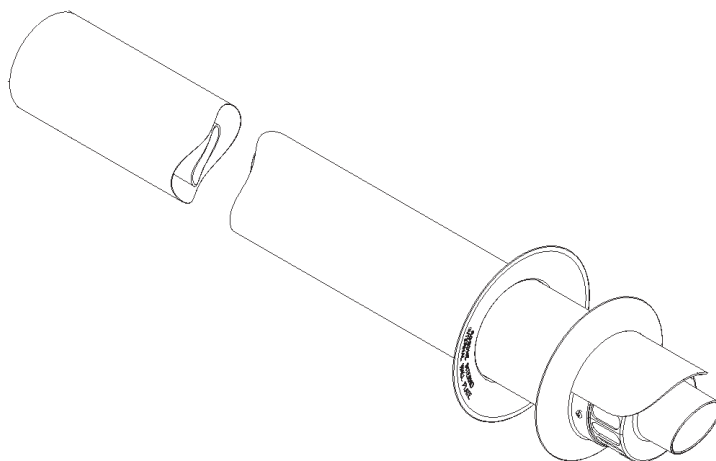

62617232

**5.16.9 - "60/100PP coaxial" system:
installation examples**

When setting up a coaxial exhaust (see Figure 5-32), whether vertical or horizontal, the exhaust pipe must slope upwards so that the condensate flows into the boiler.



WARNING! The horizontal terminal must be protected against accidental entry of rain water. To this end, it must be installed under sloping roofs (or ledges, balconies or other suitable protection) with the minimum dimensions shown in Figure 5-32.

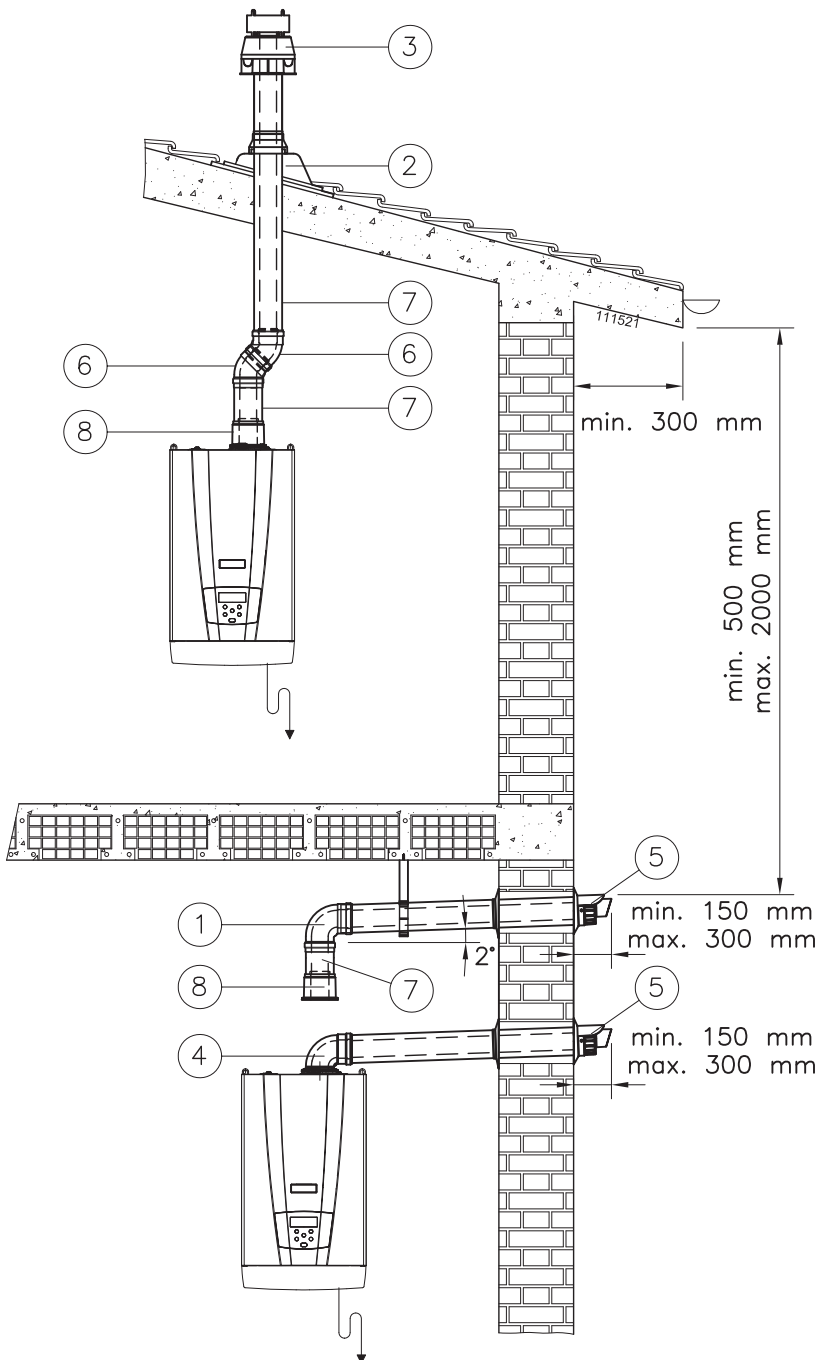

Figure 5-32 – Examples of coaxial pipe installation

5.16.10 - "80/125PP vertical coaxial" system (polypropylene) (type C13; C33) AGUADENS 37

The appliance is supplied as per standard without fittings to connect the flue gas exhaust/air intake. To connect the boiler to a 80/125 vertical coaxial system, the relevant kit must be requested and must be installed as in Figure 5-33.



WARNING! Scrupulously follow the coaxial pipe installation phases as illustrated in Figure 5-35. In particular:

- 1.- Insert coaxial pipe "C" into bend "A";
- 2.- Fix the external pipe using the stainless steel self-threading screws "B".



WARNING! The coaxial exhaust and intake pipes must be appropriately sustained via rigid brackets positioned no more than 1 metre from each other. The brackets must be fixed to rigid walls that can support the weight of the pipe itself.



WARNING! Once these operations have been performed, check that the exhaust/intake terminal is exposed to the outdoors with the tolerances given in Figure 5-36.

☞ Take particular care with the installation of pipes in the part that goes through the wall to the outside. Normal maintenance operations must always be possible; therefore, install the pipes in a sheath so that they can be slid out.

☞ The horizontal tracts must always have an inclination of at least 2% towards the boiler.

☞ The flue gas exhaust/air intake pipe can be extended up to the maximum distance indicated in the table in Section 9 at the end of the manual. Every 90° bend has a loss equivalent to the value in Section 9. Every 45° bend has a loss equivalent to the value in Section 9.

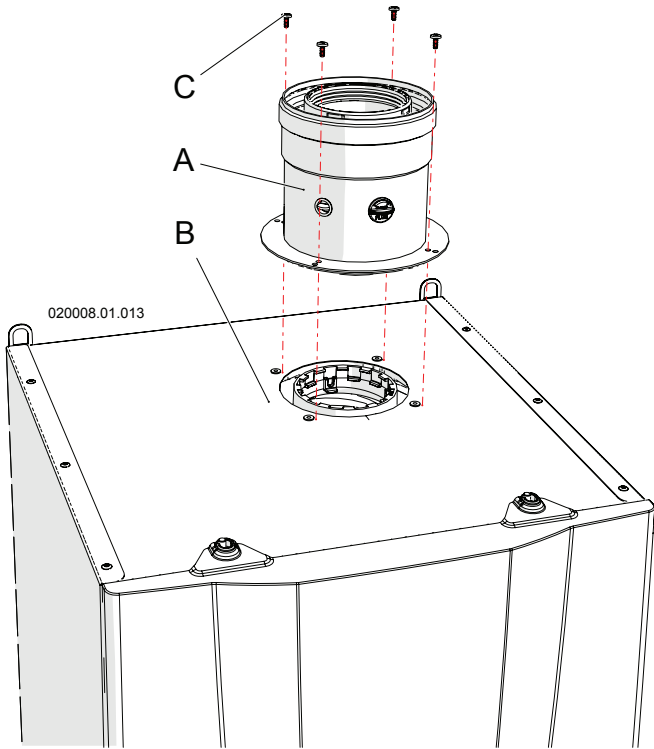

Figure 5-33 – Installation of vertical coaxial system

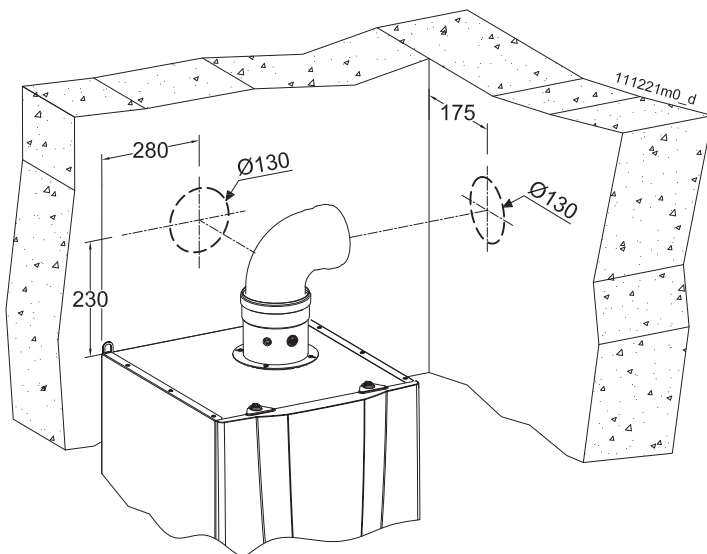

Figure 5-34 - Measurements and centre space distances for coaxial exhaust preinstallation hole

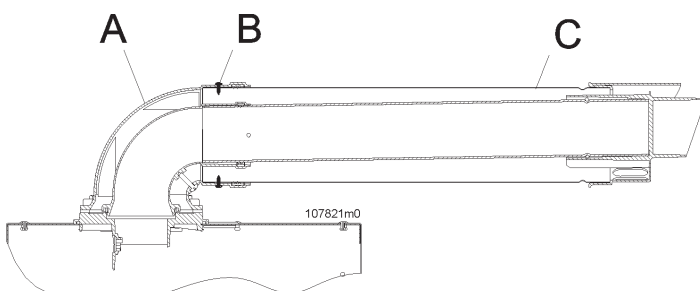
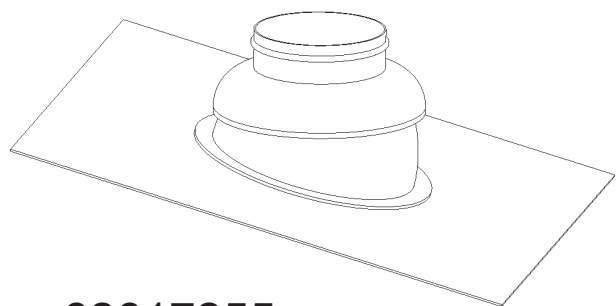

Figure 5-35 - Positioning the coaxial pipe



62617255

5.16.11 - "80/125PP coaxial" system: accessories available

The following accessories are available on request to make the 80/125 coaxial flue gas exhaust/air intake system: (the number after the code refers to the piece in the diagrams that follow)

62617255 - N° 2 valley for pitched roofs from 5° to 25°
extension L = 1000 mm

62617321 - N° 1 M/F PP 90° coaxial bend

62617322 - N° 6 M/F PP 45° coaxial bend

62617323 - N° 7 L 1m PP coaxial extension

62617325 - N° 3 PP coaxial roof terminal

62617324 - N° 5 PP coaxial wall terminal

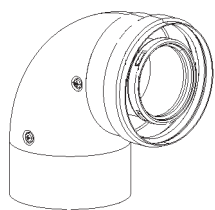

62617321

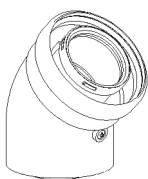

62617322



62617323

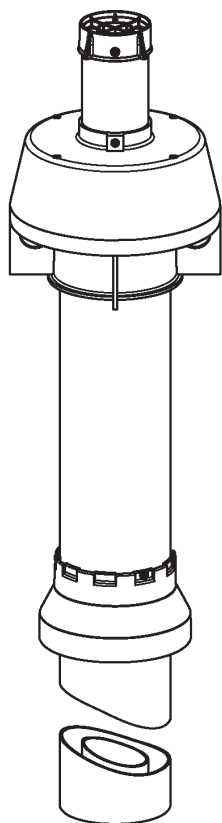

62617325

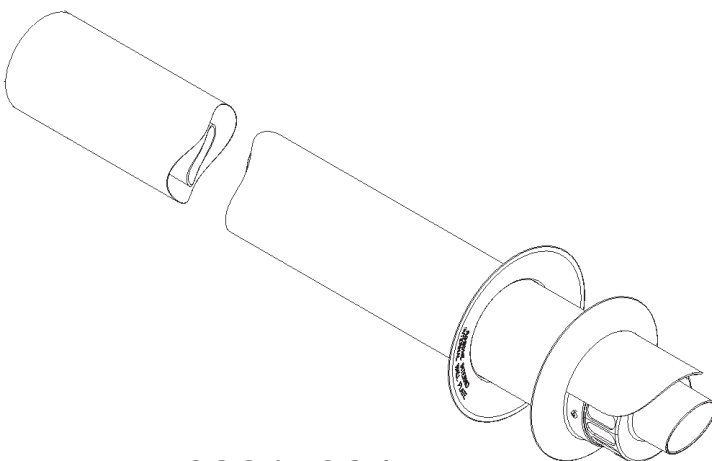

62617324

**5.16.12 - “80/125PP coaxial” system:
installation examples**

When setting up a coaxial exhaust (see Figure 5-36), whether vertical or horizontal, the exhaust pipe must slope upwards so that the condensate flows into the boiler.



WARNING! The horizontal terminal must be protected against accidental entry of rain water. To this end, it must be installed under sloping roofs (or ledges, balconies or other suitable protection) with the minimum dimensions shown in Figure 5-36.

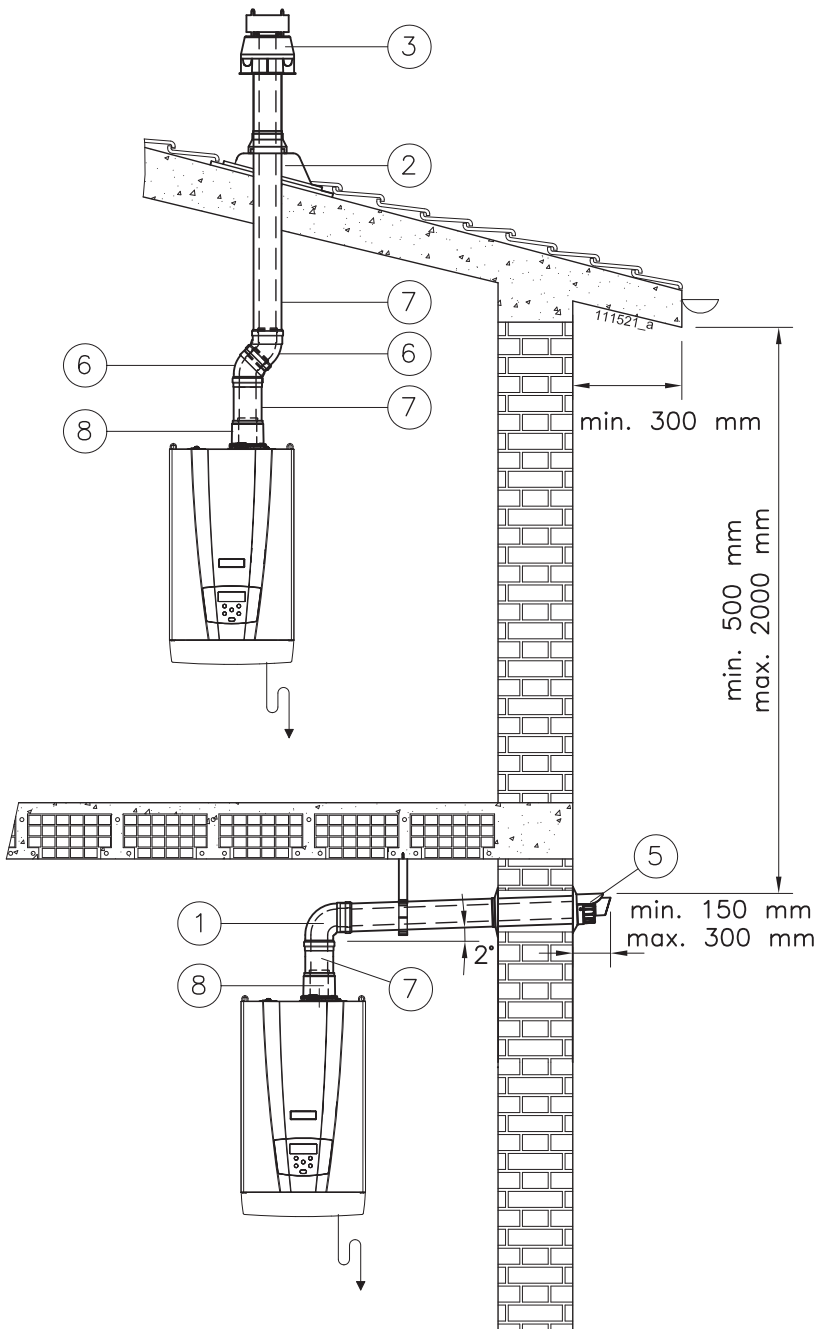

Figure 5-36 – Examples of coaxial pipe installation

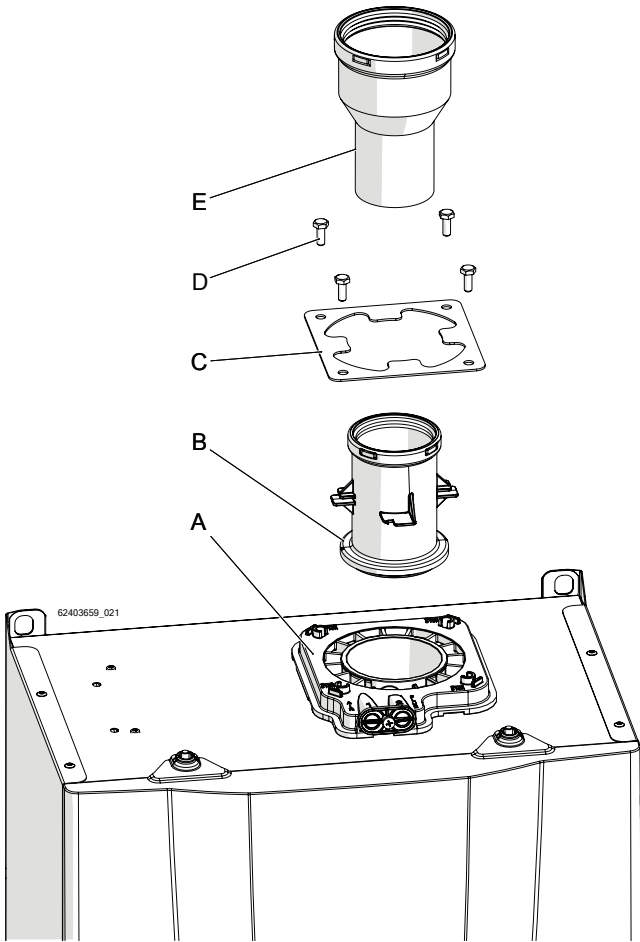

Figure 5-37 – Installing the single system

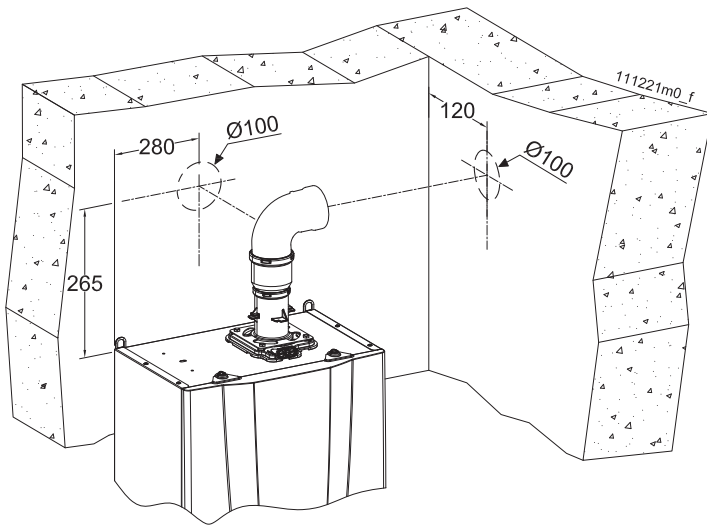

Figure 5-38 - Measurements and centre space distances for single exhaust preinstallation hole

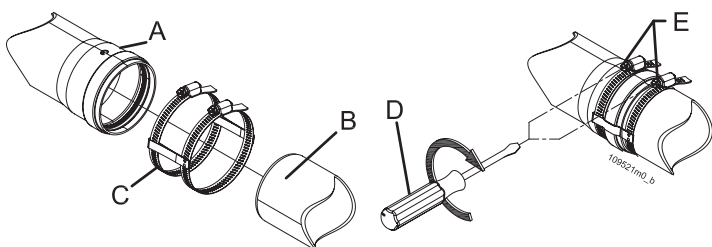

Figure 5-39 – Fixing the exhaust and intake pipes

5.16.13 - “80PP single” system (polypropylene) (type B23 or B23P) AGUADENS 16 and 22



WARNING! The appliance with this exhaust kit sucks the combustion agent air from the room where it is installed. Read and follow the precautions set out in Section 5.16.1.

The appliance is supplied as standard without fittings to connect the flue gas exhaust. To connect the appliance to a “80PP single” system, the relevant kit must be requested and must be installed as in Figure 5-37, as follows:

- 1.- Rest fitting “B” on fitting “A”;
- 2.- Fit fixing plate “C” on fitting “B”;
- 3.- Fasten fixing plate “C” on fitting “a” using the screws “D”;
- 4.- Fit the reducer “E” as shown in the figure.

Take particular care with the installation of pipes in the part that goes through the wall to the outside. Normal maintenance operations must always be possible; therefore, install the pipes in a sheath so that they can be slid out.

The horizontal tracts must always have an inclination of at least 2% towards the condensate drain device.

The boiler is already equipped with a condensate collector, which must be fitted to a drain pipe (see Section 5.7).



WARNING! This condensate drain is designed to drain away all of the liquid produced by a single appliance. If more than one boiler is installed, each boiler should have its own condensate drain.

The flue gas exhaust system can be extended up to a maximum distance as indicated in Section 9. Every 90° bend has a loss equivalent to the value in Section 9. Every 45° bend has a loss equivalent to the value in Section 9.



WARNING! The flue gas exhaust terminal must be appropriately protected against the effects of the wind (see also Section 7.8.1 error L D C C 2 2).



WARNING! Mechanically secure the joints between the various component elements of the exhaust pipe, using fixing systems or similar. See Figure 5-39



WARNING! The temperature of the exhaust pipe can reach 90°C during operation. If the pipe passes through walls that are sensitive to these temperatures, insert a protective heat-insulating sheath.



WARNING! The exhaust pipes must be appropriately sustained via rigid brackets positioned no more than 1 metre from each other. The brackets must be fixed to rigid walls that can support the weight of the pipe itself.

5.16.14 - “80PP single” system: accessories available

The accessories in Section 5.16.4 are available on request to set up an “80PP single” exhaust system.

6 - START-UP

6.1 - Start-up

Before starting up the boiler, the following operations must be carried out.

6.1.1 - Instructions to the user

Instruct the user on correct use of the boiler and the whole system in general. In particular:

- ☞ Hand over the installation and use manual and all the documentation contained in the package to the user.
- ☞ Instruct the user on any special measures for discharging burned gases, informing them that they must not be modified.
- ☞ Inform the user regarding the correct temperature, control unit/room thermostat and radiator settings for saving energy.

6.1.2 - Filling the condensate drain siphon

The siphon found inside the boiler (see Figures 3-2 and 3-4, detail "40") must be filled with water to create the head capable of preventing the flue gas escaping from pipe "F" in Figure 5-8. Proceed as follows to do this: (refer to Figure 6-1 for models 16 and 22 and to Figure 6-2 for models 37)

- 1.- Loosen screw "E";
- 2.- Remove lid "D" and gaskets "C";
- 3.- Insert a rubber hose into opening "B" (do not confuse with "A") and the other end of the hose into a funnel;
- 4.- Use the funnel to slowly pour in about 200 cm³ of water (= a glass);
- 5.- Refit all parts in reverse order.

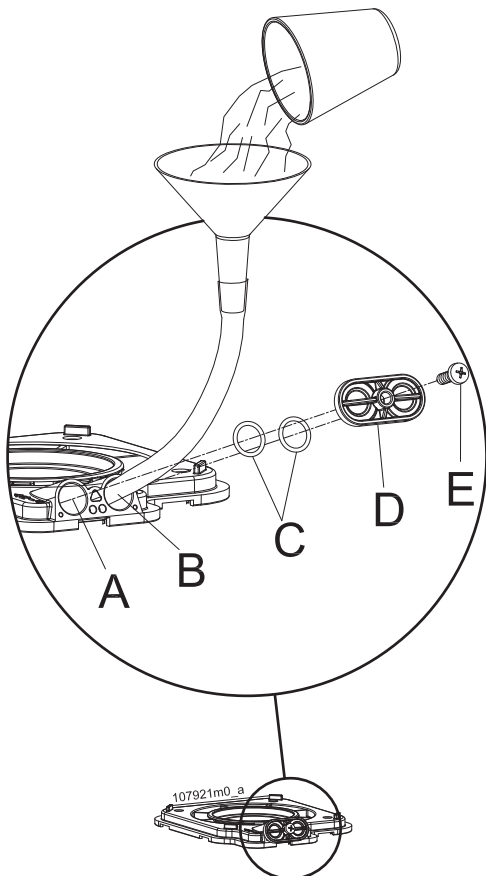

Figure 6-1 – Filling the condensate drain siphon Models 16 and 22.



WARNING! If the boiler remains off for more than 3 months, the siphon must be filled again as explained above.

6.2 - General recommendations regarding the gas supply

To commission the boiler, have a professionally qualified technician perform the following checks:

- ☞ That the boiler is powered by the type of fuel for which it is set up.
- ☞ That the gas supply pressure (with boiler operating and stopped) is within the maximum and minimum values indicated in the table in Section 9 at the end of the manual.
- ☞ That the gas adduction system has all the safety and checking devices expected by national and local regulations in force.
- ☞ That the flue gas outlet terminal and the combustion agent air intake terminal are free from any obstruction.
- ☞ That the flue gas outlet terminal and the combustion air intake terminal are located outside the building.
- ☞ That the condensate drain connection is connected.



WARNING! If you smell gas:

- A - Do not switch on any electric devices, including telephones, or use any object that might cause sparks;**
- B - Immediately open doors and windows to create a draught that can quickly clear the gas from the room;**
- C - From another room, or from a neighbour's property, immediately call a professionally qualified technician or the gas supply company. Call the Fire Service if the former are not available.**

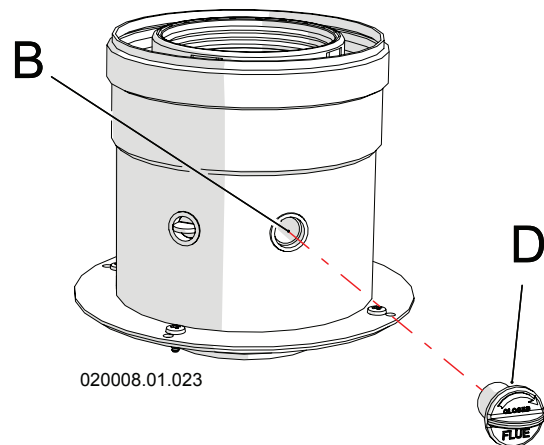

Figure 6-2 – Filling the condensate drain siphon Model 37

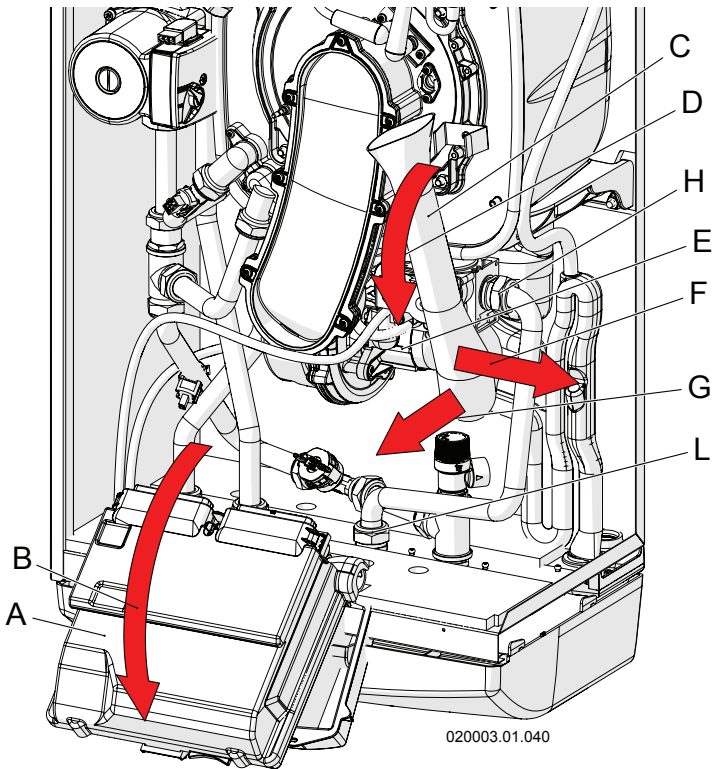

Figure 6-3 – Removing the air manifold

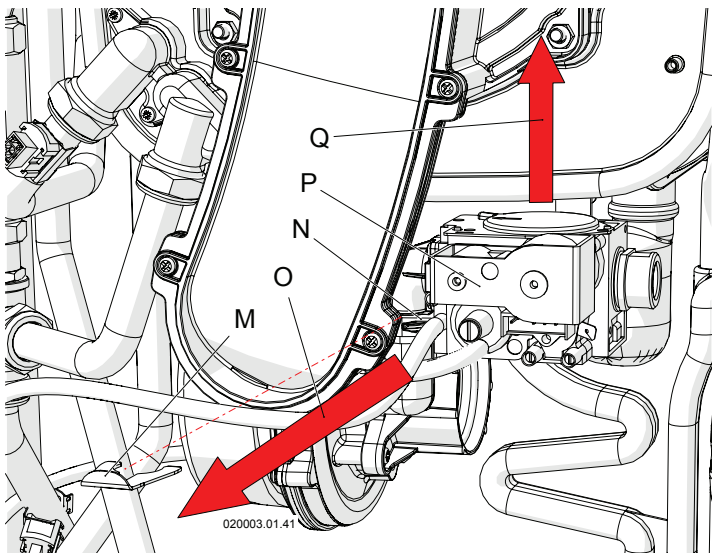

Figure 6-4 – Removing the gas valve

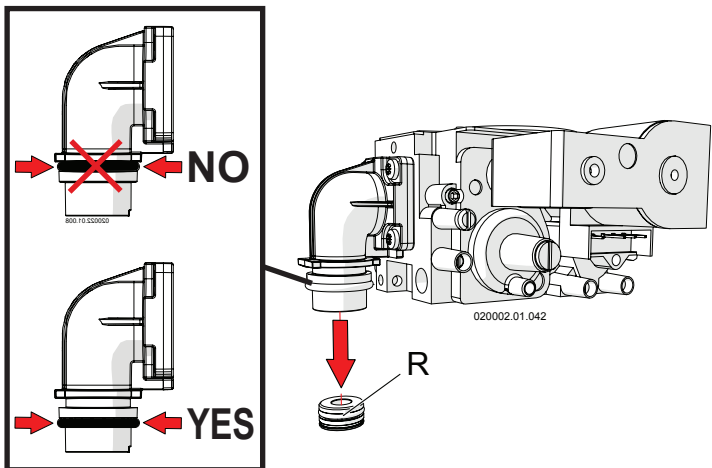

Figure 6-5 – Replacing the gas nozzle

6.3 - Type of gas for which the appliance is set.

There is a label on the front of the appliance certifying the gas supply type and pressure for which the boiler is set. The boiler may have one of the following two types of wording:

2H-G20-20mbar NATURAL GAS

This means that the boiler is set to operate with G20 gas (methane) of group H of the second family, at a supply pressure of 20 mbar.

3P-G31-37mbar LPG

This means that the boiler is set to operate with G31 gas (propane, also known as LPG) of group P of the third family, at a supply pressure of 37 mbar.

6.4 - Conversion of the appliance from one type of gas to another



Read these instructions carefully before changing the gas:

- The gas appliance must be installed, calibrated or modified by specialised staff in compliance with the law;
- Check and be certain that the type of gas which is powering the appliance is compatible with the adjustment kit in your possession;
- Do not supply the boiler with a type of gas other than those specified.

- 1.- Access the "installer" profile (see Section 7.7);
- 2.- Set parameter ~~2 138~~ to the value shown in the table shown in Figure 6-7;
- 3.- Turn off electricity to the boiler;
- 4.- Open the boiler casing as reported in Section 8.3;
- 5.- Close the gas supply;
- 6.- Remove the air manifold, making sure to rotate it outwards and then slide it out of the fan inlet (see Figure 6-3, detail "C");
- 7.- Remove the gas inlet pipe using the two fittings (see Figure 6-3, details "H" and "L");
- 8.- Remove clamp spring "M" from seat "N" releasing valve "P" (see Figure 6-4);
- 9.- Slide gas valve "P" up and out;
- 10.- Replace gas nozzle "R" (see Figure 6-5) with an appropriate one according to Figure 6-7 under "Gas nozzle diameter";
- 11.- Refit the gas valve (see Figure 6-4, detail "P"), taking care to reposition spring "M";
- 12.- Refit the gas supply pipe via the two fittings (see Figure 6-3, details "H" and "L");
- 13.- Refit the air manifold (see Figure 6-3, detail "C");
- 14.- Open the gas cock;
- 15.- Check for any gas leaks using the relevant tools;



WARNING! Perform the gas leak test using a soap and water solution only. The use of naked flames is prohibited.



WARNING! If you smell gas:

- A - Do not switch on any electric devices, including telephones, or use any object that might cause sparks;**
- B - Immediately open doors and windows to create a draught that can quickly clear the gas from the room;**
- C - From another room, or from a neighbour's property, immediately call a professionally qualified technician or the gas supply company. Call the Fire Service if the former are not available.**

- 16.- Check the supply gas pressure, following the procedure in Section 6.6;
- 17.- Open the CO₂ adjustment screw completely (see Figure 6-8, detail "A");
- 18.- Check and adjust the CO₂, following the procedure in Section 6.7;
- 19.- Apply the sticker certifying the appliance's new setting onto the front casing of the boiler in place of the label showing the old status (see Figure 6-6): apply label "B" if the boiler has been converted from natural gas to LPG; apply label "A" if the boiler has been converted from LPG to natural gas.

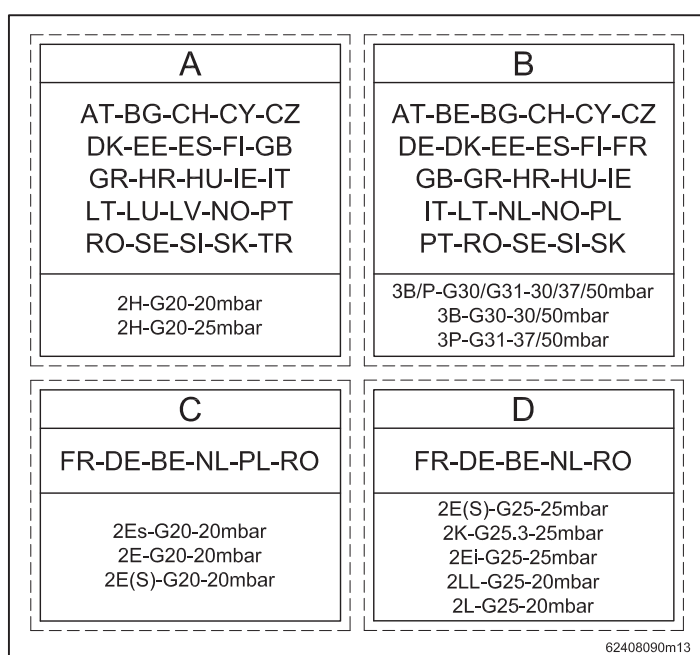
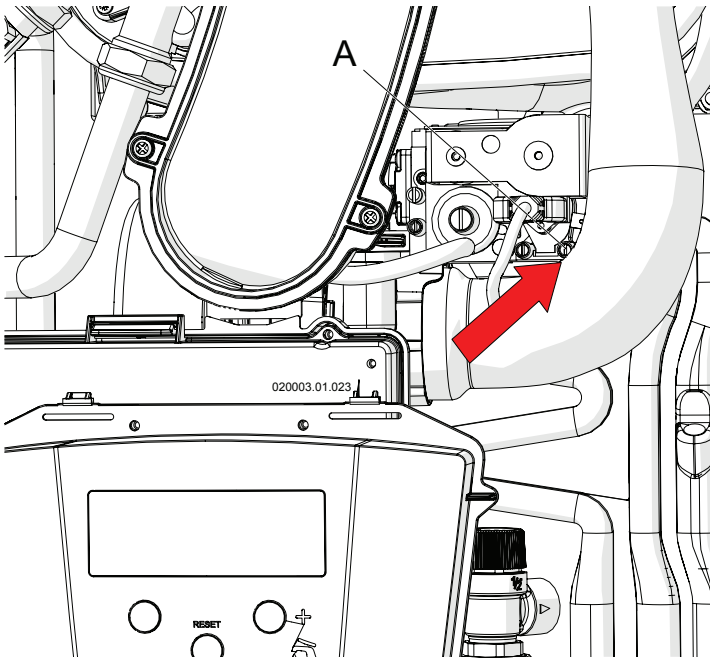

Figure 6-6 – Labels certifying the new boiler status

Model	Type of gas	Setting parameter	Gas supply minimum pressure (mbar)	Gas supply maximum pressure (mbar)	Gas nozzle diameter (mm)	CO ₂ Maximum power (%)	CO ₂ Minimum power (%)	O ₂ Maximum power (%)	O ₂ Minimum power (%)
16	G20	50	17	25	4.5	9.0 ± 0.3	8.5 ± 0.1	4.9 ± 0.2	5.8 ± 0.1
	G25	50	20	30	4.9	9.0 ± 0.3	8.5 ± 0.1	4.5 ± 0.2	5.4 ± 0.1
	G30	51	25	35	3.1	10.5 ± 0.3	9.5 ± 0.1	5.2 ± 0.2	6.7 ± 0.1
	G31	51	25	45	3.3	10.5 ± 0.3	9.5 ± 0.1	4.9 ± 0.2	6.4 ± 0.1
22	G20	52	17	25	6.0	9.0 ± 0.3	8.5 ± 0.1	4.9 ± 0.2	5.8 ± 0.1
	G25	52	20	30	6.7	9.0 ± 0.3	8.5 ± 0.1	4.5 ± 0.2	5.4 ± 0.1
	G30	53	25	35	4.1	10.5 ± 0.3	9.5 ± 0.1	5.2 ± 0.2	6.7 ± 0.1
	G31	53	25	45	4.5	10.5 ± 0.3	10.0 ± 0.1	4.9 ± 0.2	5.6 ± 0.1
37	G20	54	17	25	8.0	8.7 ± 0.3	8.3 ± 0.1	5.4 ± 0.2	6.1 ± 0.1
	G25	52	20	30	10.0	8.7 ± 0.3	8.3 ± 0.1	5.0 ± 0.2	5.8 ± 0.1
	G30	55	25	35	5.2	10.1 ± 0.3	9.5 ± 0.1	5.9 ± 0.2	6.8 ± 0.1
	G31	55	25	45	5.7	10.1 ± 0.3	9.5 ± 0.1	5.5 ± 0.2	6.4 ± 0.1

Figure 6-7 – Correspondence table for parameter and the operating values



A - Gas inlet pressure point.

Figure 6-8 – Gas valve

6.5 - Ignition

- 1.- Open the gas cock;
- 2.- Power the boiler electrically;
- 3.- Adjust the desired temperature for the domestic hot water service using the + and - keys. The icon on the display shows the DHW service operating status:
 - a) fixed icon: domestic hot water inactive (no-one is using domestic hot water or, where there is a storage tank, the delivery temperature has been reached);
 - b) flashing icon: domestic hot water service in use.
- 4.- open the hot water tap to the maximum to get rid of air from inside the hot water heater. If the flow of water is limited, open two or three taps to get rid of the air completely. In models 37 it is possible to help by opening the manual bleed valve (see detail "47" in Figure 3-4).

6.6 - Controlling the supply gas pressure and any adjustments

The gas supply pressure must correspond to that stated in the table in Section 9 at the end of the manual. Proceed as follows to verify the pressure:

- 1.- Close the gas cock;
- 2.- Access the boiler's internal parts by following the procedure described in Section 8.3;
- 3.- Loosen pressure point "A" (see Figure 6-8);
- 4.- Connect a manometer with a resolution of at least 0.1 mbar (1 mmH₂O) to it;
- 5.- Open the gas cock;
- 6.- Check that the pressure does not exceed the value given in the table in Section 9 under "Gas supply maximum pressure";
- 7.- Open a domestic hot water tap to the maximum;
- 8.- Wait for the hot water heater temperature to stabilise;
- 9.- Check that the pressure does not drop to a value lower than the "Gas supply minimum pressure" given in the table in Section 9. If the supply pressure does not respect the values described, operate on the system upstream from the appliance in order to bring it back to within the minimum and maximum range;
- 10.- Close the domestic hot water tap again;
- 11.- Close the pressure point "A" again as in Figure 6-8;
- 12.- Check for any gas leaks at the pressure point using suitable tools.



WARNING! Perform the gas leak test using a soap and water solution only. The use of naked flames is prohibited.

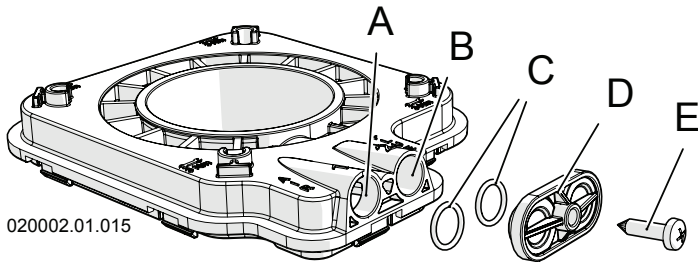

**Figure 6-9 – Combustion analysis points
Models 16 -22**

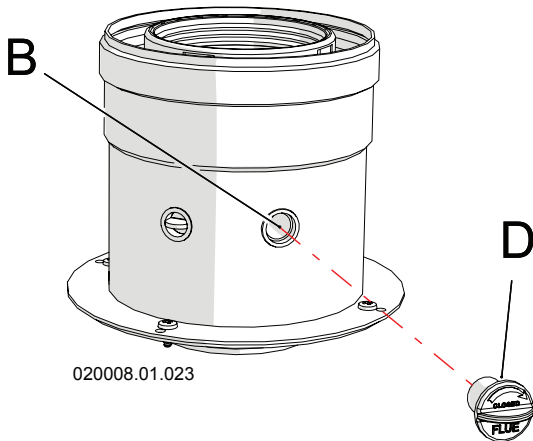

**Figure 6-10 – Combustion analysis points
Model 37**

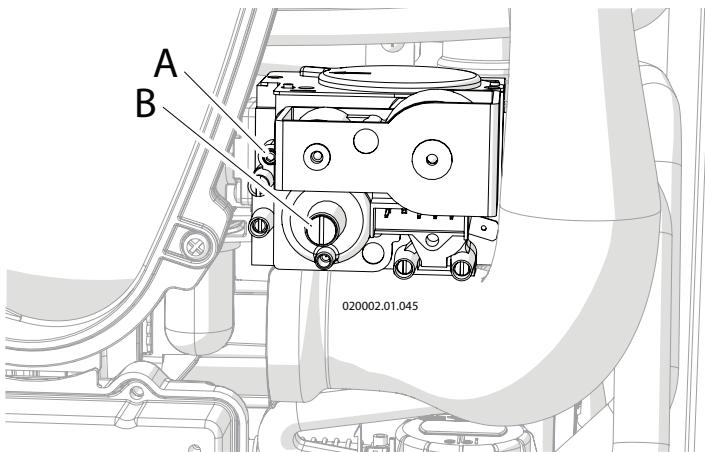

A - CO2 adjustment screw at maximum power
B - CO2 adjustment screw at minimum power

Figure 6-11 – Gas valve

6.7 - Controlling the level of CO2 and any adjustments

The boiler in normal operating mode, and for altitudes up to 1000 m, has a level of CO2 (carbon dioxide) in the flue gas as shown in the table in Section 9. A combustion analysis must be performed to check and adjust the CO2 level as required. Proceed as follows:

- 1.- Start up the boiler;
- 2.- Connect a combustion analyser to the appropriate point on the flue gas exhaust fitting "B" in Figure 6-9 and 6-10;
- 3.- Open at least one domestic hot water tap to the maximum;
- 4.- Access the "installer" profile as detailed in Section 7.7;
- 5.- Set parameter **0200** to **H 1** (see Section 7.6);
- 6.- Now the burner will operate at maximum power for 10 minutes;
- 7.- Wait for the CO2 measurement to stabilise;
- 8.- Compare the value measured with that given in the table in Figure 6-7, "CO2 maximum power". If the value measured differs from the value read, it must be brought back to within the value given in the table in Figure 6-7, proceeding as follows:
 - a) Turn screw "A" clockwise as in Figure 6-11 to decrease the level of CO2;
 - b) Turn screw "A" anti-clockwise as in Figure 6-11 to increase the level of CO2;
- 9.- Once the check has been completed, seal the screw "A" in Figure 6-11 with red paint or a similar method;
- 10.- Access the "installer" profile again as detailed in Section 7.7 and set parameter **0200** to **L 0** (see Section 7.6);
- 11.- Now the burner will operate at minimum power for 10 minutes;
- 12.- Wait for the CO2 measurement to stabilise;
- 13.- Compare the value measured with that given in the table in Figure 6-7, "CO2 minimum power". If the value measured differs from the value read, it must be brought back to within the value given in the table in Figure 6-7, proceeding as follows:
 - a) Turn screw "B" anti-clockwise as in Figure 6-11 to decrease the level of CO2;
 - b) Turn screw "B" clockwise as in Figure 6-11 to increase the level of CO2;
- 14.- Once the check has been completed, seal screw "B" in Figure 6-11 with red paint or a similar method;
- 15.- Access the "installer" profile again as detailed in Section 7.7 and set parameter **0200** to **OFF** (see Section 7.6);
- 16.- Close the domestic hot water taps previously opened.

6.8 - Automatic learning and calibration of minimum and maximum power

This appliance has an automatic learning procedure to achieve the best adjustment of the water temperature. To do this the hot water heater automatically calibrates the maximum and minimum power depending on what are the typical uses of the place in which it is installed.

Since at first ignition the typical uses are unknown, the first automatic learning process is done as follows:

- 1.- Open a hot water tap completely;
- 2.- With key  +, increase the temperature to the maximum;



WARNING! A hot water temperature exceeding 51°C may cause permanent injury/damage to persons, animals and objects.

In particular, protect children, the elderly and people with disabilities against any possible risks of scalds, by inserting devices that limit the usage temperature of the DHW to users.

- 3.- The appliance will start up at the system's maximum power where it is installed; Wait 5 minutes;
- 4.- Now the maximum power has been calibrated;
- 5.- Go into the "User Profile" (Section 7.7) and set parameter **0200** to **L** (see Section 7.6);
- 6.- Now the hot water heater will operate at minimum power; Wait at least 5 minutes;
- 7.- Now the minimum power has been calibrated;
- 8.- Turn the hot water heater off and on again;
- 9.- Close the hot water tap;
- 10.- Now the hot water heater has learned the working limits of this installation and will adjust the temperature of the hot water to the best level.

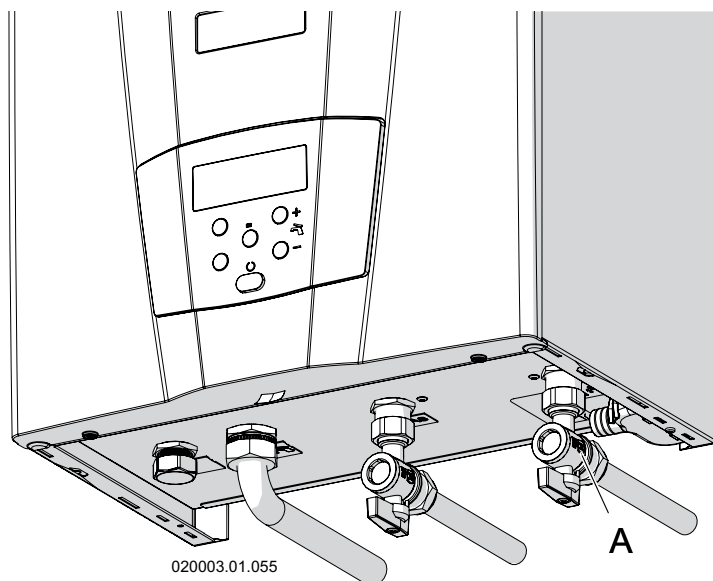



Figure 6-12 – Domestic hot water flow rate selector switch ("A")

6.9 - Adjusting the domestic hot water flow rate

If the appliance is installed in a geographical area where the temperature of the cold water is very low, the flow rate of domestic hot water that passes inside the boiler may have to be reduced. It is therefore good practice to perform the following adjustment:

- 1.- Switch the boiler on;
- 2.- Using the  + and  - keys, adjust the temperature of the domestic hot water to 48°C-50°C;
- 3.- Open a hot water tap completely. In the case of a single lever mixer tap, the position must be completely on "HOT";
- 4.- Wait 3 minutes for the temperature to stabilise;
- 5.- If the water temperature is too cold, the flow rate must be reduced using a cock located upstream of the appliance, until the desired temperature is reached (see Figure 6-12, detail "A").

6.10 - Checking the maximum heat input

The hot water heater is set with a standard air/gas mix ratio at the factory. The gas pressure at the burner is controlled indirectly by the fan.

The only way to control the maximum heat input is to directly adjust the gas meter.

To do this, proceed as follows:

- 1.- Turn on the appliance using switch "A" in Figure 7-1;
- 2.- Go into the installer menu (Section 7.8) and set parameter **0200** to **H**. Now the hot water heater will operate at maximum power for 20 minutes;
- 3.- Open the domestic hot water cock completely;
- 4.- Measure the inlet flow rate using the gas meter. This Figure must correspond with the value shown in the "Technical Data" (see Section 9) under the heading "maximum heat input", with a tolerance of +/-10%;
- 5.- If the gas flow rate is too low, check:
 - a) that there are no obstructions in the combustion agent air system and/or in the flue gas outlet system;
 - b) check that the length of the flue and of the air intake are lower than the maximum specified in the "Technical Data" Section, in Section 9;
 - c) check that the heat exchanger and the burner are clean (Section 8.5).

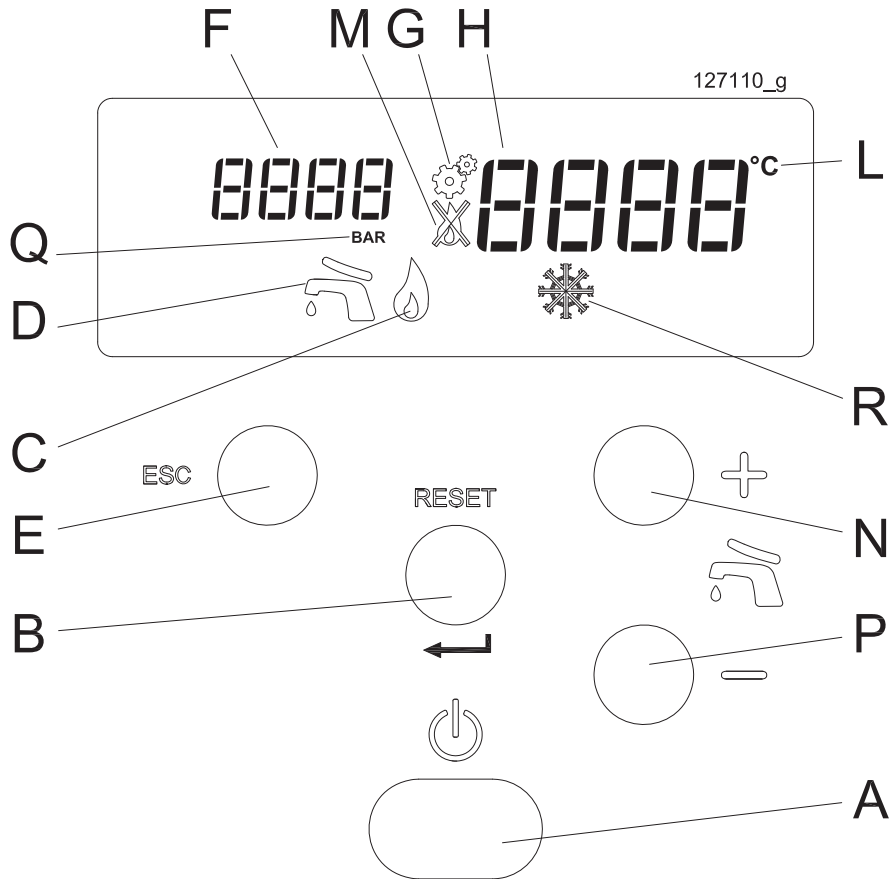

Figure 7-1 – Control board
Figure 7-1 key

- A - On/off switch
- B - Reset and confirm parameters button
 - To reset a lockout, hold the button down until the letters rSt appear on the display
 - To confirm a parameter, press and release immediately
- C - Burner status (the burner is on when this icon is showing)
- D - Domestic hot water service status:
 - Icon off = Domestic hot water off
 - Icon on = Domestic hot water on but not in operation
 - Icon flashing = Domestic hot water on and in operation
- E - Exit profiles button
- F - Indicator of different parameters within the different menus
- G - Icon to enter the “installer” menu
- H - Temperature of the domestic hot water or indicator of the values taken on by the various parameters
- L - Unit of measurement of the temperature displayed
- M - Boiler in lockout (see Sections 7.8.1 and 7.8.2 for the diagnostics)
- N - Button for switching on and increasing the temperature of the domestic hot water or for scrolling through and changing the value of the parameters
- P - Button for reducing the temperature of the domestic hot water (below the minimum, the domestic hot water is set to OFF) or for scrolling through and changing the value of the parameters
- Q - Unit of measurement of the pressure displayed
- R - Appliance in anti-freeze mode

7.1 - General information

During operation, the display shows the boiler operating status as well as other information as indicated in Section 7.8 (Diagnostics).

Other parameters can be consulted through the “User profile” (see Section 7.6), useful for understanding appliance operation and checking the most recent lockouts or errors.

7.2 - Ignition procedure

- 1.- Open the gas cock;
 - 2.- Power the boiler electrically;
 - 3.- Adjust the domestic hot water temperature as shown in Section 7.3;
 - 4.- Open a hot water tap;
- The command and control equipment will switch the burner on. If ignition does not take place within 50 seconds (the boiler automatically attempts ignition again 3 times), it locks out and

the display shows **Loc I**.



Press the RESET button to restore normal operating conditions.

The boiler will automatically attempt to ignite again.



WARNING! If shutdown due to lockout occurs frequently, contact a qualified technician to restore normal operating conditions.

7.3 - Adjusting the hot water temperature

The temperature of the domestic hot water is adjusted using the  and  keys. Once one of the two keys has been pressed, the display "H" in Figure 7-1 starts to flash and show the temperature that is being set. The temperature of the domestic hot water can be set to between 40°C and 60°C.

By pressing and holding the  key down even below 40°C, the message "OFF" appears which indicates that the domestic hot water service is being switched off. The icon "D" in Figure 7-1 also switches off.

7.4 - Time settings for the various functions

To protect the lifespan of the appliance, improve comfort, and increase energy savings, time settings have been introduced during operation. These time settings are as follows:

- Pump post-circulation: whenever the domestic hot water service ends, the pump continues to operate for 40 seconds;
- Pumps anti-lock function: every 24 hours the recirculation pump and the storage tank supplementary loading pump (where present) are forced;
- Anti-legionella: if the boiler is connected to a storage tank for preparing DHW, every seven days the storage tank is forced to a temperature of 60°C to disinfect it and protect against legionella bacteria. This function is also activated two hours after the boiler has been powered electrically.

7.5 - Anti-freeze protection



WARNING! For the anti-freeze protection to be effective, the appliance must be left with the electrical power supply and gas supply present and the service (domestic hot water) in the OFF position.





WARNING! The anti-freeze protection service offered by the boiler cannot guarantee anti-freeze protection of the domestic hot water system or the building served, or parts of the same.

The pump turns on automatically when the boiler temperature reaches 7°C. If the temperature drops further to below 2°C, the burner also ignites to protect the boiler from the effects of freezing. If the boiler is not used for a long period of time (over a year), empty it following the procedure in Section 8.13.





7.6 - “User profile”

Each time the appliance is switched on, the “user profile” opens by default.

To adjust the domestic hot water set point, press keys  and .

To display the parameters that are available for consultation in this profile, press the RESET button once. Display “F” in

Figure 7-1 shows parameter **0.000**.

Press the  and  keys to scroll through the parameters within this profile. Once the desired parameter has been found, press the ENTER key to select it. Then use keys  and  to change it and press the RESET key again to confirm the change.

To exit the parameter, press the **ESC** key.

To exit parameter consultation mode, press the **ESC** key. If no key is pressed for more than 60 seconds, consultation mode is exited automatically.

The following parameters can be examined in this profile:

Parameter	Description of the parameter	Access level	U.M.	Setting range	Factory value
0003	Central heating temperature requested (N/A)	User	°C	OFF...80	60
0048	DHW temperature requested	User	°C	OFF...60	50
0200	Forcing	Installer	Test	OFF = No forcing FAN = fan only at maximum speed Lo = burner at minimum power Ign = burner at ignition power Hi = burner at maximum power rEg = burner at power regulated by parameter 2014; Stb = Burner stopped (N/A); LCO01 = Safety input 1 test (N/A) LCO02 = Safety input 2 test (N/A)	OFF
0901	Temperature unit of measurement	Factory	°C/°F	C/F	C
0902	Pressure unit of measurement	Factory	bar/psi	bar/psi	bar
0910	Selection of what to see in the 4 digits of the display	User	/	0: Display of the temperature selected via parameter 0911 1: Burner status 2: Alternate display of temperature and burner status 3: Display of the “OK” message	0
0911	Temperature selection recalled by parameter 0910	User	/	0: Heating or DHW depending on the service active at that time 1: Heating 2: DHW 3: N/A 4: Cascade temperature	0
0990	Forcing duration	Factory	min	10...240	0
0997	Display icon test	User			
0998	Installer access code	Factory	Code	0000-9999	0300
0999	Factory access code	Factory	Code	0000-9999	/

Parameters for consultation only:

Parameter	Description of the parameter	Access level	U.M.
1001	Heat exchanger temperature	User	°C
1002	Domestic hot water temperature (or storage tank temperature, where present)	User	°C
1003	Cold water temperature (N/A)	User	/
1004	External temperature (N/A)	User	°C
1005	Heat exchanger temperature (according to sensor)	User	°C
1006	Flue gas temperature	User	°C
1007	Cold water inlet temperature	User	°C
1008	Ionisation current (see Section 8.15)	User	µA
1012	Temperature required by climatic curve or by input 0-10 V (N/A)	User	°C
1013	Recirculation timer input status (OPEN = no central heating request; CLOSED = central heating request)	User	OPEN/CLOSED
1014	Flue gas temperature (according to sensor) (N/A)	User	(N/A)
1015	Cascade temperature (N/A)	User	°C
1017	Dependent setpoint cascade	User	°C
1018	Gas pressure switch input (N/A)	User	OPEN/CLOSED
1019	Flow switch input	User	OPEN/CLOSED
1020	Air pressure switch input (N/A)	User	OPEN/CLOSED
1030	Burner status (2 = Stand by; 8 = Flame present; 11 = Post-circulation pump);	User	Value
1031	Error code	User	Value
1033	Central heating water pressure (N/A)	User	bar
1040	Current fan speed	User	RPM
1041	Fan speed at ignition	User	RPM
1042	Fan speed at minimum power	User	RPM
1043	Fan speed at maximum power	User	RPM
1051	Last lockout code (Loc) (see Section 7.8.1) (255 means no lockouts)	User	Value
1052	Last error code (Err) (see Section 7.8.2) (255 means no errors)	User	Value
1053	Number of failed flames	User	Value
1054	Number of successful ignition attempts	User	Value
1055	Number of failed ignition attempts	User	Value
1056	Operating hours in heating mode (N/A)	User	hx10
1057	Operating hours in domestic hot water mode	User	hx10
1058	Total operating days (power supply to the appliance)	User	days
1059	Time between last two lockouts (Loc)	User	1: mins 2: hours 3: days 4: weeks
1060	Time between last two errors (Err)	User	1: mins 2: hours 3: days 4: weeks
1061	Instant turbine speed	User	RPM
1062	Domestic hot water flow rate	User	l/min
1063	Input 0-10 V	User	volt
1090	Days until maintenance (negative when the deadline has expired)	User	days
1098	Command board version	User	Hexadecimal
1099	Appliance software version	User	Hexadecimal
1995	Display software version	User	Hexadecimal

* N/A = Not applicable;

7 - USE

7.7 - “Installer profile”



WARNING! Changing these parameters could cause boiler and therefore system malfunctions. For this reason, only a technician with an in-depth knowledge of the appliances can modify them.

To analyse the operation and adaptation of the appliance to the system, the technician has access to the parameters below via the “installer profile”.

To access this profile:

1.- Press the RESET key; the display “F” in Figure 7-1

shows parameter **0.000**. Use keys + and - to scroll to the **Code** parameter and press RESET to access it;

2.- Type the code **0300** in the following way:

use keys + and - to select the values:

0 and confirm with the RESET key;

3 and confirm with the RESET key;

0 and confirm with the RESET key;

0 and confirm with the RESET key;

3.- The + and - keys can be used to scroll through the parameters within this profile;

4.- Once the desired parameter is displayed, it can be changed as follows:

a.- Press the RESET key to access the parameter (the display “H” in Figure 7-1 starts to flash);

b.- Edit the value of the parameter using the + and - keys;

c.- Press the RESET key to confirm the change and go back to the list of parameters.

5.- Press the **ESC** key twice to exit.

If no key is pressed for more than 5 minutes, the menu returns to the “user” profile. Any changes to data that have not been confirmed using the RESET key will be lost.



WARNING! Any variations made to the parameters must be noted in the “Customised values” column in the following table, in order to facilitate any future replacements of the command and control board.

The following parameters can be changed or examined in this profile:

Parameter	Description of the parameter	Access level	U.M.	Setting range	Factory value	Customised values
2001	Central heating mode (N/A)	Installer	#	0 = Constant temperature with TA; 1 = Climatic with TA; 2 = Climatic compensated by TA; 3 = Constant temperature compensated by TA; 4 = Control from input 0-10 V with TA; 5 = N/A	0	
2003	Central heating temperature requested (N/A)	Installer	°C	30-80	60	
2005	Pump post-circulation	Installer	Secs	0-900	120	
2006	Maximum flue gas temperature	Factory	°C	10-120	95	
2007	Heat exchanger positive hysteresis	Factory	°C	0-20	5	
2009	Delay against frequent burner ignition	Installer	Secs	10-900	180	
2010	Temperature differential against frequent burner ignition	Installer	°C	0-20	16	
2012	Maximum differential heat exchanger temperature	Factory	°C	10-80	80	
2014	Central heating maximum power (N/A)	Installer	%	1-100	75	
2015	Central heating minimum power (N/A)	Installer	%	1-75	1	
2016	Heating PID factor P (N/A)	Factory	#	0-1275	20	
2017	Heating PID factor I (N/A)	Factory	#	0-1275	100	
2019	Clim - Winter heating temperature (N/A)	Installer	°C	20-90	80	
2020	Clim - Winter external temperature (N/A)	Installer	°C	-25 to 25	-5	
2021	Clim - Spring heating temperature (N/A)	Installer	°C	20-90	40	
2022	Clim - Spring external temperature (N/A)	Installer	°C	0-30	20	
2023	Minimum heating temperature (Takes priority over parameter 2021) (N/A)	Installer	°C	0-80	30	
2024	Maximum heating temperature (Takes priority over parameter 2019) (N/A)	Installer	°C	27-90	80	
2025	Clim - Spring temperature central heating off (N/A)	Installer	°C	0-35	22	

7 - USE

Parameter	Description of the parameter	Access level	U.M.	Setting range	Factory value	Customised values
2026	Heating acceleration increase (N/A)	Installer	°C	0-30	0	
2027	Heating acceleration delay (N/A)	Installer	min	1-120	0	
2028	Night heating reduction by opening TA (N/A)	Installer	°C	0-30	10	
2035	DHW mode	Installer	#	0 = No domestic hot water; 1 = Puffer with temperature sensor; 2 = Puffer with thermostat; 3 = N/A; 4 = N/A; 5 = Plate heat exchanger; 6 = N/A; 7 = Hot water heater with recirculation control; 8 = Hot water heater;	8	
2036	Puffer negative hysteresis	Factory	°C	0-20	3	
2037	Puffer positive hysteresis	Factory	°C	0-20	3	
2038	Delivery temperature increase for puffer	Installer	°C	0-30	0	
2039	Puffer fill delivery negative hysteresis	Factory	°C	0-20	5	
2040	Puffer fill delivery positive hysteresis	Factory	°C	0-20	5	
2041	Puffer maintenance temperature (N/A)	Factory	°C	0-10	5	
2042	DHW priority mode with puffer	Installer	#	0 = Time (time set under par. 2043); 1 = Heating priority; 2 = DHW priority; 3 = N/A;	2	
2043	DHW/heating priority timing	Installer	min	1-255	60	
2044	DHW post-circulation	Installer	Secs	0-900	40	
2045	Puffer PID factor P	Factory	#	0-1275	50	
2046	Puffer PID factor I	Factory	#	0-1275	270	
2048	DHW temperature requested	Installer	°C	40-80	50	
2049	Instant DHW negative hysteresis	Factory	°C	0-20	5	
2050	Instant DHW positive hysteresis	Factory	°C	0-20	5	
2051	Instant DHW PID factor P	Factory	#	0-1275	50	
2052	Instant DHW PID factor I	Factory	#	0-1275	270	
2060	DHW flow rate detection	Factory	l/min	0.1-20.0	2.5	
2061	Flow rate at which the setpoint can be reached at minimum power (N/A)	Factory	l/min		2.5	
2062	Flow rate at which the setpoint can be reached at maximum power (N/A)	Factory	l/min		2.5	
2063	DHW modulation timing ON/OFF	Factory	Secs		30	
2064	DHW recirculation pre-heat mode (only for 2035 = 7)	Installer	#	0 = Off; 1 = Antifreeze (N/A) 2 = Eco (recirculation kept at value set under 2065); 3 = Comfort (recirculation kept at DHW temperature);	0	
2065	ECO recirculation temperature (see par. 2064)	Factory	°C	20-60	30	
2069	Recirculation pre-heat negative hysteresis	Factory	°C	0-30	0	
2070	Recirculation pre-heat positive hysteresis	Factory	°C	0-30	5	
2071	Recirculation pre-heat delay	Factory	Secs	0-15	10	
2091	Maximum DHW temperature setting	Installer	°C	50-90	60	
2092	Maximum fan speed setting	Factory	RPM	1750-9999		
2093	Minimum fan speed setting	Factory	RPM	500-7050		
2094	Fan speed ignition setting	Factory	RPM	1950-7050		

7 - USE

Parameter	Description of the parameter	Access level	U.M.	Setting range	Factory value	Cus-tomised values
2096	Minimum DHW temperature setting	Installer	°C	20-50	40	
2109	Climatic offset adjustment (parameter 2001 = 1 or 2) (N/A)	Installer	°C	OFF - 10-10	0	
2110	Minimum heating temperature setting (N/A)	Installer	°C	20-50	20	
2111	Maximum heating temperature setting (N/A)	Installer	°C	50-90	80	
2112	Central heating negative hysteresis (N/A)	Factory	°C	0-20	5	
2113	Maximum power in DHW mode	Installer	%	50-100	100	
2114	Minimum power in DHW mode	Installer	%	1-30	1	
2115	DHW puffer temperature setting	Installer	°C	20-80	50	
2116	Programmable input J7 2-3 Central heating pressure sensor	Installer	#	0 = Disabled 1 = Enabled 2 = N/A 3 = N/A	0	
2117	Programmable input J7 7-8 1 = Instant DHW flow sensor; 2 = Instant DHW thermostat; 3 = Heat exchanger flow sensor;	Installer	#	0 = Disabled 1 = Enabled point 1 2 = Enabled point 2 3 = Enabled point 3 4 = N/A;	1	
2118	Programmable input J7 9-10	Installer	#	0 = Disabled 2 = N/A	0	
2120	Programmable input J6 3-10 Return temperature sensor	Installer	#	0 = Disabled 1 = Enabled	1	
2121	Programmable input J6 5-12 Flue gas temperature sensor	Installer	#	0 = Disabled 1 = Enabled 2 = N/A	1	
2122	Programmable input J6 6-13 Cascade sensor	Installer	#	0 = Disabled 1 = N/A 3 = Enabled	3	
2123	Programmable input J7 2-4	Installer	#	0 = Disabled 1 = N/A 3 - 6 = N/A	0	
2124	Room thermostat programmable input	Installer	#	0 = Disabled 1 = Enabled	1	
2125	Programmable output 1 J3 3-8 6 = Alarm 7 = Automatic filling	Installer	#	0 = Disabled 1-5 = Not applicable 6 = Enabled point 6 7 = Enabled point 7	0	
2126	Programmable output 2 J3 5-10 9 = External spark generator	Factory	#	0 = Disabled 1-8 = N/A 9 = Enabled point 9 10 = N/A	9	
2127	Programmable output 3 J3 6	Installer	#	0 = Disabled 1-10 = N/A	0	
2128	Output setting 18 = 3-way DHW valve in standby 20 = 3-way central heating valve in standby	Installer	#	0 = Disabled 1-17 = N/A 18 = Enabled point 18 19 = N/A 20 = Enabled point 20	20	
2129	Domestic hot water flow rate sensor	Installer	#	0 = Bitron 1 = Huba DN8 2 = Huba DN10 3 = Huba DN15 4 = Huba DN20 5 = N/A	16 = 1; 22 = 3; 37 = 3;	

7 - USE

Parameter	Description of the parameter	Access level	U.M.	Setting range	Factory value	Customised values
2130	Domestic hot water flow rate factor (N/A)	Installer	l/min	0-25.5	3.2	
2131	Minimum central heating water pressure (N/A)	Installer	bar	OFF 0.1-5.0	0.8	
2132	Automatic filling hysteresis (N/A)	Installer	bar	OFF 0.1-1.0	0.5	
2133	Modulating pump temperature differential (N/A)	Installer	°C	5-40	15	
2134	Modulating pump ignition time (N/A)	Installer	Secs	0-255	120	
2135	Type of modulating pump (N/A)	Installer	#	0 = Wilo Yonos; 1 = Salmson; 2 = Grundfos;	0	
2136	Modulating pump mode (N/A)	Installer	#	0 = Not modulating 1 = Modulating 2 = N/A 3 = N/A 4 = fixed speed at 40% 5 = fixed speed at 50% 6 = fixed speed at 60% 7 = fixed speed at 70% 8 = fixed speed at 80% 9 = fixed speed at 90% 10 = fixed speed at 100%	10	
2137	Minimum pump modulation power (N/A)	Installer	%	0-100	40	
2138	Fan speed map	Installer	#	50-55	16 = 50; 22 = 52; 37 = 54;	
2139	Air bleed function (N/A)	Installer		0-2	0	
2140	Minimum heat exchanger water flow rate	Installer	l/min/10	0-10	0.8	
2141	Rated heat exchanger water flow rate	Installer	l/min/10	0-10	16 = 1; 22 = 1; 37 = 4.3;	
2201	Enable/disable central heating	Installer		EnA = Enabled dIS = Disabled	EnA	
2202	Enable/disable domestic hot water	Installer		EnA = Enabled dIS = Disabled	EnA	
2203	Setting maintenance requests	Installer		ON = On OFF = Off RST = Reset	OFF	
2204	Days until maintenance request	Installer	days	30-1275	1000	
2205	Anti-freeze protection	Installer		EnA = Enabled dIS = Disabled	EnA	
2206	Anti-legionella	Installer		EnA = Enabled dIS = Disabled	EnA	
2207	DHW detection delay	Installer	secs	0-255	1	

7.7.1 - Parameters for cascade systems



WARNING! Changing these parameters could cause boiler and therefore system malfunctions. For this reason, only a technician with an in-depth knowledge of the appliances can modify them.

For systems with appliances installed in a cascade, the following parameters can be changed or examined (accessible from the installer profile only):

Parameter	Description of the parameter	Access level	U.M.	Setting range	Factory value	Customised values
4072	Emergency mode	Installer		NO/YES	NO	
4074	Emergency temperature	Installer	°C	20-90	45	
4075	Next module ignition delay	Installer	Secs	5-1275	60	
4076	Next module shutdown delay	Installer	Secs	5-1275	60	
4077	Module ignition negative hysteresis	Factory	°C	0-20	5	
4078	Module shutdown positive hysteresis	Factory	°C	0-20	5	
4079	Cascade temperature maximum decrease	Installer	°C	0-20	6	
4080	Cascade temperature maximum increase	Installer	°C	0-20	6	
4081	Modulation delay	Installer	min	0-60	1	
4082	Next module insertion power	Installer	%	10-100	80	
4083	Next module removal power	Installer	%	10-100	40	
4084	Rotation interval	Installer	days	0-30	5	
4086	Cascade temperature control PID, parameter P	Factory	#	0-1275	20	
4087	Cascade temperature control PID, parameter I	Factory	#	0-1275	300	
4142	Next module rapid ignition delay	Installer	Secs	5-1275	30	
4143	Next module rapid shutdown delay	Installer	Secs	5-1275	30	
4144	Module rapid ignition negative hysteresis	Factory	°C	0-20	5	
4145	Module rapid shutdown positive hysteresis	Factory	°C	0-20	5	
4146	All module shutdown positive hysteresis	Installer	°C	0-20	7	
4147	Number of modules in cascade (Master included)	Installer	#	0-8	0	
4148	Power management 0 = modulation on cascade temperature; 1 = minimum number of active modules; 2 = maximum number of active modules; 3 = balanced number of active modules;	Installer	#	0 = Enabled point 0 1 = Enabled point 1 2 = Enabled point 2 3 = Enabled point 3	2	
4149	First module igniting (due to rotation)	Installer	#	1-8	1	
4150	Positive power turn PID	Factory	#	0-26	0	
4151	Negative power turn PID	Factory	#	0-26	0	
4152	Power management 2 (parameter 4148) – Minimum power	Installer	%	0-100	10	
4153	Power management 2 (parameter 4148) – hysteresis	Installer	%	0-100	40	
4154	Cascade pump post-circulation	Installer	Secs	0-255	60	
4155	Cascade sensor anti-freeze temperature	Installer	°C	10-30	15	
4184	Module logical address	Installer	#	0-8	0	

7.8 - Diagnostics

During normal appliance operation, the display “H” in Figure 7-1 shows the working status of the appliance via the following indications:

Parameter	Description of the parameter	Displayed on display “H” in Figure 7-1
<i>AlEe</i>	Boiler not locked out but alarm pending	Alarm code (see Section 7.8.3 for code key)
<i>Loc</i>	Boiler in lockout mode. To reset, press and hold the RESET button until the <i>rSt</i> message is displayed. If the lockout occurs frequently, contact a professional qualified technician	Lockout code (see Section 7.8.1 for code key)
<i>Err</i>	Boiler in error mode. Restore operation by resolving the cause of the anomaly. Contact a professionally qualified technician	Error code (see Section 7.8.2 for code key)
<i>ALeS</i>	Anti-legionella function running (see Section 5.14.1). It will end when the water inside the storage tank reaches a temperature of 60°C.	Storage tank temperature (°C)
<i>SEr</i>	Boiler maintenance request	

7.8.1 - Diagnostics: lockouts “Loc”

Once the type of “Loc” has been displayed and the appropriate checks and solutions have been carried out, reset the appliance by pressing and holding the RESET button (detail “B” in Figure 7-1) until the “rSt” message is displayed.

Lockout	Lockout description	Checks	Solutions
Loc 0	Internal memory error E2prom at command board		Replace the command and control board.
Loc 1	No flame detection after three successive ignition attempts	Check: supply gas pressure (see Section 6.6), sparks on the ignition electrodes (see Section 8.6); 230 VAC electric power supply to the gas valve; electric resistance of the two gas valve coils of 0.88 kohm and 6.59 kohm.	If the supply pressure is not correct, adjust the components before the appliance to restore the correct value. If the current at the gas valve is not 230 VAC, replace the command and control board. If the electric resistance of the gas valve is not 0.88 kohm and 6.59 kohm, replace the valve.
		If the burner comes on and goes off at the end of the ignition attempt, check: that the ionisation current is above 4 (see Section 8.15)	If the ionisation current is not over 4, check the CO ₂ (see Section 6.7) and restore it to the correct value. Check the ionisation spark plug and replace it if necessary. Check the integrity of the ionisation current electric circuit cables.
Loc 2	Gas valve command relay broken		Replace the command and control board.
Loc 3	The appliance has reached the maximum intervention temperature	Check that the pump works;	Restore the water circulation or replace the command and control board;
		Check that the electrical resistance of the two sensors matches the graph in Section 8.16;	If either or both of the sensors are not within the correct values, replace them;
		Check that the high limit flue gas temperature fuse has not been triggered;	If the high limit flue gas temperature fuse has been triggered (the contact is open), contact the manufacturer before replacing it; WARNING! Before replacing it, contact the manufacturer.
Loc 4	Boiler in error mode for more than 20 hours	Check the last error displayed on the board.	Respond according to the last error displayed.
Loc 5	Fan stopped for more than 60 seconds	Check it is powered at 230 VDC.	If the fan is powered, it must be replaced; otherwise, replace the command board.
Loc 6	Fan too slow for more than 60 seconds	Check it is powered at 230 VDC.	If the fan is powered, it must be replaced; otherwise, replace the command board.
Loc 7	Fan too fast for more than 60 seconds	Check it is powered at 230 VDC.	If the fan is powered, it must be replaced; otherwise, replace the command board.
Loc 8	Software error on the command board		Replace the command board.
Loc 9	Content of the command board internal memory E2prom not updated		Replace the command board.

7 - USE

Lockout	Lockout description	Checks	Solutions
Loc 10	E2prom memory parameters incorrect		Replace the command board.
Loc 11	Software error on the command board		Replace the command board.
Loc 12	Software error on the command board		Replace the command board.
Loc 13	Software error on the command board		Replace the command board.
Loc 14	Software error on the command board		Replace the command board.
Loc 15	Flue fuse	Check that the high limit flue gas temperature fuse has not been triggered	If the high limit flue gas temperature fuse has been triggered (the contact is open), contact the manufacturer before replacing it; WARNING! Before replacing it, contact the manufacturer.
	The heat exchanger temperature exceeds 105°C with the gas valve closed	Check that the electrical resistance of the two supply sensors matches the graph in Section 8.16. Check that the gas valve closes the gas correctly when the burner switches off.	If one of the two sensors does not match, the double supply sensor must be replaced. The gas valve must be replaced if it does not close correctly.
	Exchanger malfunction	Check that the primary heat exchanger temperature fuse has not intervened	If the primary heat exchanger temperature fuse has intervened (the contact is open), the exchanger must be replaced.
Loc 16	Exhaust flue maximum temperature. WARNING! If the lock is repeated more than once a day, turn off the appliance and contact a qualified service centre. DO NOT ATTEMPT TO REPAIR THE APPLIANCE.	Check that there isn't any air in the heat exchanger;	Vent the air from the appliance.
		Check that the circulation pump is operating correctly;	If the pump is not working, it must be replaced.
		Check that the flue exhaust temperature is not more than 30°C above the cold water temperature.	If the difference between the cold water temperature and the flue gas temperature is above 30°C, contact a qualified service centre.
		Measure the boiler efficiency; it must correspond to the value declared in the technical features.	If the efficiency does not correspond to the data at the end of the manual, the primary heat exchanger is probably dirty on the flue gas side or the water side. Clean and check efficiency again.
Loc 17	Software error on the command board		Replace the command board.
Loc 18	Software error on the command board		Replace the command board.
Loc 19	Software error on the command board		Replace the command board.
Loc 20	Flame present 10 seconds after gas valve is closed		Replace the gas valve or the command board.
Loc 21	Flame present before ignition		Replace the gas valve or the command board.
Loc 22	Flame lost three times	Check that the ionisation current is above 4 (see Section 8.15)	If the ionisation current is not over 4, check the CO2 (see Section 6.7) and restore it to the correct value. Check the ionisation spark plug and replace it if necessary. Check the integrity of the ionisation current electric circuit cables.
		Check that the flue gas exhaust is properly protected against obstructions caused by gusts of wind	If the flue gas outlet is on a vertical wall it must be protected by a windproof grill; if the flue gas outlet is on the roof, check that it is not in a area where there is flowback, and that any windproof chimney that may be provided is really effective
Loc 23	Software error on the command board		Replace the command board.
Loc 24	Software error on the command board		Replace the command board.
Loc 25	The two supply sensors measure temperatures that are at least 10°C different for more than 60 seconds.	Check that the electrical resistance of the two sensors matches the graph in Section 8.16;	If either or both of the sensors are not within the correct values, replace them;

7 - USE

Lockout	Lockout description	Checks	Solutions
Loc 26	Software error on the command board		Replace the command board.
Loc 27	Too many system loads in one hour (N/A)		Replace the command board.
Loc 28	System filling time too long (N/A)		Replace the command board.
Loc 29	Software error on the command board		Replace the command board.
Loc 30	Software error on the command board		Replace the command board.
Loc 31	Software error on the command board		Replace the command board.
Loc 32	Software error on the command board		Replace the command board.
Loc 33	Software error on the command board		Replace the command board.
Loc 34	Software error on the command board		Replace the command board.
Loc 35	Software error on the command board		Replace the command board.
Loc 36	Software error on the command board		Replace the command board.
Loc 37	Software error on the command board		Replace the command board.
Loc 38	Software error on the command board		Replace the command board.
Loc 39	Defect measure power voltage ADC		Replace the command board.

7.8.2 - Diagnostics: errors "Err"

Error	Error description	Checks	Solutions
Err 100	Software error on the command board		Replace the command board.
Err 101	Software error on the command board		Replace the command board.
Err 102	Software error on the command board		Replace the command board.
Err 103	Software error on the command board		Replace the command board.
Err 104	Software error on the command board		Replace the command board.
Err 105	The supply temperature exceeds 95°C with the gas valve closed	Check that the electrical resistance of the two supply sensors matches the graph in Section 8.16.	If one of the two sensors does not match, the double supply sensor must be replaced.
		Check that the gas valve closes the gas correctly when the burner switches off.	The gas valve must be replaced if it does not close correctly.
Err 106	Software error on the command board		Replace the command board.
Err 107	Software error on the command board		Replace the command board.
Err 108	Software error on the command board		Replace the command board.
Err 109	Software error on the command board		Replace the command board.
Err 110	Software error on the command board		Replace the command board.
Err 111	0-10 V input polarity reversed	Check the polarity input 0-10 V	Restore correct polarity
	Software error on the command board		Replace the command board.
Err 112	Software error on the command board		Replace the command board.
Err 113	0-10 V input polarity reversed	Check the polarity input 0-10 V	Restore correct polarity
	Software error on the command board		Replace the command board.
Err 114	Flame detected at a moment when it should not be		Replace the gas valve or the command board.
Err 115	Low central heating water pressure (N/A)		
Err 116	Low central heating water pressure (N/A)		
Err 117	Software error on the command board		Replace the command board.
Err 118	Software error on the command board		Replace the command board.
Err 119	Cold water sensor circuit (1007) open	Check that the electric resistance of the sensor matches the graph in Section 8.16. Check the electric cables for connection between the sensor and the command board.	If the electric resistance does not match, replace it. If the electric circuit is damaged, repair it. Where neither of the two previous cases apply, replace the command board.
Err 120	Heat exchanger sensor 1 circuit (1001) open	Check that the electric resistance of the sensor matches the graph in Section 8.16. Check the electric cables for connection between the sensor and the command board.	If the electric resistance does not match, replace it. If the electric circuit is damaged, repair it. Where neither of the two previous cases apply, replace the command board.
Err 121	Heat exchanger sensor 2 circuit (1005) open	Check that the electric resistance of the sensor matches the graph in Section 8.16. Check the electric cables for connection between the sensor and the command board.	If the electric resistance does not match, replace it. If the electric circuit is damaged, repair it. Where neither of the two previous cases apply, replace the command board.
Err 122	Domestic hot water sensor circuit (1002) open	Check that the electric resistance of the sensor matches the graph in Section 8.16. Check the electric cables for connection between the sensor and the command board.	If the electric resistance does not match, replace it. If the electric circuit is damaged, repair it. Where neither of the two previous cases apply, replace the command and control board.

7 - USE

Error	Error description	Checks	Solutions
Err 123	Flue gas sensor circuit 1 (1006) open	Check that the electrical resistance of the flue gas sensor 1006 matches the graph in Section 8.16	If the sensor does not match, the double flue gas sensor must be replaced.
		Check that the wires between the board and the double flue gas sensor are connected correctly	If the wires are not connected correctly, the connections must be restored.
Err 124	Flue gas sensor circuit 2 (1014) open (N/A)	Check that the electrical resistance of the flue gas sensor 1014 matches the graph in Section 8.16	If the sensor does not match, the double flue gas sensor must be replaced.
		Check that the wires between the board and the double flue gas sensor are connected correctly	If the wires are not connected correctly, the connections must be restored.
Err 125	External temperature sensor circuit (1004) open (N/A)	External temperature sensor not present (1004) (N/A)	External temperature sensor not present (1004) (N/A)
Err 126	Cold water sensor circuit (1007) short circuit	Check that the electric resistance of the sensor matches the graph in Section 8.16. Check the electric cables for connection between the sensor and the command board.	If the electric resistance does not match, replace it. If the electric circuit is damaged, repair it. Where neither of the two previous cases apply, replace the command and control board.
Err 127	Heat exchanger circuit sensor 1 (1001) short circuit	Check that the electric resistance of the sensor matches the graph in Section 8.16. Check the electric cables for connection between the sensor and the command board.	If the electric resistance does not match, replace it. If the electric circuit is damaged, repair it. Where neither of the two previous cases apply, replace the command and control board.
Err 128	Heat exchanger circuit sensor 2 (1005) short circuit	Check that the electric resistance of the sensor matches the graph in Section 8.16. Check the electric cables for connection between the sensor and the command board.	If the electric resistance does not match, replace it. If the electric circuit is damaged, repair it. Where neither of the two previous cases apply, replace the command and control board.
Err 129	Domestic hot water sensor circuit (1002) short circuit	Check that the electric resistance of the sensor matches the graph in Section 8.16. Check the electric cables for connection between the sensor and the command board.	If the electric resistance does not match, replace it. If the electric circuit is damaged, repair it. Where neither of the two previous cases apply, replace the command and control board.
Err 130	Flue gas sensor circuit 1 (1006) short circuit	Check that the electrical resistance of the flue gas sensor 1006 matches the graph in Section 8.16	If the sensor does not match, the double flue gas sensor must be replaced
		Check that the wires between the board and the double flue gas sensor are connected correctly	If the wires are not connected correctly, the connections must be restored
Err 131	Flue gas sensor circuit 2 (1014) short circuit (N/A)	Check that the electrical resistance of the flue gas sensor 1014 matches the graph in Section 8.16	If the sensor does not match, the double flue gas sensor must be replaced
		Check that the wires between the board and the double flue gas sensor are connected correctly	If the wires are not connected correctly, the connections must be restored
Err 133	Incorrect electrical mains frequency	Check that the electrical frequency is 50 Hz	If the frequency is not 50 Hz, contact your electricity supplier
			If the frequency is 50 Hz, replace the command board
Err 134	RESET key pressed too many times in short period	Wait 5 seconds after each press of the RESET key	
Err 135	Software error on the command board		Replace the command board.
Err 136	Software error on the command board		Replace the command board.
Err 137	Software error on the command board		Replace the command board.
Err 138	Software error on the command board		Replace the command board.
Err 139	Software error on the command board		Replace the command board.
Err 140	Software error on the command board		Replace the command board.
Err 141	Software error on the command board		Replace the command board.
Err 142	Software error on the command board		Replace the command board.
Err 143	Software error on the command board		Replace the command board.
Err 144	Software error on the command board		Replace the command board.

7 - USE



Error	Error description	Checks	Solutions
Err 145	Software error on the command board		Replace the command board.
Err 146	Software error on the command board		Replace the command board.
Err 147	Software error on the command board		Replace the command board.
Err 148	Software error on the command board		Replace the command board.
Err 149	Software error on the command board		Replace the command board.
Err 150	Software error on the command board		Replace the command board.
Err 151	Software error on the command board		Replace the command board.
Err 152	Software error on the command board		Replace the command board.
Err 153	Software error on the command board		Replace the command board.
Err 154	Software error on the command board		Replace the command board.
Err 155	Software error on the command board		Replace the command board.
Err 156	Software error on the command board		Replace the command board.
Err 157	Software error on the command board		Replace the command board.
Err 158	Software error on the command board		Replace the command board.
Err 159	Software error on the command board		Replace the command board.
Err 160	Software error on the command board		Replace the command board.
Err 161	Software error on the command board		Replace the command board.
Err 162	Low central heating water pressure (N/A)		
Err 163	Software error on the command board		Replace the command board.
Err 164	Low water flow error (just for 2117=3)	Check that the water flow (1062) is higher than the value of parameter 2140	<ul style="list-style-type: none"> - Check that the pump is working. - Check that there are no obstructions that prevent water circulation. - Check that the heat exchanger is not blocked.
Err 165	Supply current too low	Power supply current too low for more than 60 seconds	
Err 166	Supply current too high	Power supply current too high for more than 60 seconds	
Err 168	Maximum flue gas temperature. CAUTION!!! If the block is repeated for more than once a day, switch off the appliance and contact a qualified service center. DO NOT ATTEMPT TO RESTORE IT.	Check that there is no air in the heat exchanger.	Vent the air from the appliance.
		Check that the circulation pump is working properly.	If the pump does not work, it must be replaced.
		Check that the flue gas temperature is not higher than 30 ° C of the cold water temperature.	If the difference between cold water temperature and flue gas temperature exceeds 30 ° C, contact a qualified service center.
		Perform a measurement of the performance of the appliance, it must correspond to what stated in the technical characteristics.	If the yield does not correspond to the data at the end of the manual, the primary heat exchanger is probably dirty either from the smoke side or from the water side. Clean it and perform a performance check again.
Err 169	Software error on the command board		Replace the command board.
No Conn	Display communication error	Check the correct connection to the display and to the water flow sensor.	



N/A = Not applicable;

7.8.3 - Diagnostics: alarms “AttE”

Alarm	Alarm description	Checks	Solutions
AttE 200	Lost cascade communication	System with appliances in a cascade. The cascade management system has lost the connection with one of the appliances. Possible causes: a - one of the appliances in the cascade is OFF; b - the communication BUS between the appliances (A-Link) is interrupted at one or more points; c - parameters 4184 and/or 4147 are not set according to cascade rules d - the S4 switches are not positioned as described in the Section according to cascade rules	a - switch the appliance off by resolving the problem that caused it to shut down; b - restore the BUS communication between the appliances; c - set parameters 4184 and/or 4147 correctly, according to cascade rules d - position the S4 switches as described according to cascade rules
AttE 201	Protective anode active	N/A	Replace the command and control board
AttE 202	Connected appliance recognition error	N/A	Replace the command and control board
AttE 203	Communication lost with appliance connected in cascade	N/A	Replace the command and control board
AttE 204	External probe error (contact open or short-circuited)	Check the electrical resistance of the sensor; Check that it has been connected correctly.	If the electric resistance does not match, replace it. If the electric circuit is damaged, repair it. Where neither of the two previous cases apply, replace the command and control board.
AttE 205	Cascade probe error (contact open or short-circuited)	Check the electrical resistance of the sensor; Check that it has been connected correctly.	If the electric resistance does not match, replace it. If the electric circuit is damaged, repair it. Where neither of the two previous cases apply, replace the command and control board.
AttE 206	Cascade probe error (contact open or short-circuited)	N/A	Replace the command and control board

7.9 - Turning the appliance on and off

To turn off the boiler, press keys  + and  - at the same time. The word **OFF** will appear on the display; then press key  - to switch to **OFF**; then RESET to confirm.

To turn the boiler back on, press keys  + and  - at the same time. The word **OFF** will appear on the display; then press key  + to switch to **ON**; then RESET to confirm.

8.1 - General recommendations

A regular annual maintenance check on the appliance is advised for the following reasons:

- to maintain high efficiency of the appliance and therefore save fuel;
- to maintain a high level of safety;
- to maintain the high level of combustion environmental compatibility.

In order to maintain the frequency of maintenance, there is a parameter **2203** in the installer menu (see Section 7.7), which is used to activate the maintenance call (Service),

along with parameter **2204** which is used to set the operating days that must elapse between one call and the next.

The control system identifies the operating days, checking the burner activity time.

Proceed as follows to activate the call service:

1.- Access the Installer profile (see Section 7.7) and set parameter **2203** to **On**;

2.- Access parameter **2204** and set the boiler operating days which must elapse between one call and the next.

The call will be executed with the message “**SER**” on the display. To remove the message “**SER**” and renew the call period, do as follows:

1.- Access the “Installer” profile;

2.- Access parameter **2203** and set it to **Off**.

The call time has now been reset and the message “**SER**” appears on the display.



WARNING! Appliance maintenance must be carried out only by a professionally qualified technician.



WARNING! During maintenance operations, to ensure the appliance operates correctly, check its condition and operation, and check for any water leaks from any of the air vent valves on the appliance.



WARNING! Before any maintenance work, disconnect the appliance from the electrical power supply, using the relevant switch nearby.



WARNING! Before any maintenance operation turn off the gas cock

8.2 - Maintenance protocol

- Clean the burner and the primary heat exchanger (flue gas side); check the condition of the thermal insulators and seals
(See Section 8.5);
- Check there are no water leaks
(See Section 8.2.1);
- Check the gas supply pressure; check for gas leaks
(Follow Sections 6.6 and 8.2.2);
- Check and clean the condensate drain system
(See Section 8.9);
- Check the condition of the safety valve
(See Section 8.2.3);
- Check the condition of the safety and control devices
(See Section 8.2.4);
- Check the condition of the electrical system
(See Section 8.2.5);
- Check the burner is calibrated correctly in DHW mode
(See Section 6.7);
- Check the operation of the main switch and correct adjustment of the temperature in DHW mode
(See Sections 8.2.6 and 8.2.7);
- Check that the no gas device is triggered and check the intervention time
(See Section 8.2.8);
- Check the condition of the air intake and flue exhaust ducts
(See Section 8.2.9);
- Check the ignition and detection electrodes
(See Sections 8.2.10 and 8.6);
- Check the condition and operation of the air vent valves
(See section 8.2.11);

8.2.1 - Checking there are no water leaks

1. - Check for leaks in the hydraulic connections.



WARNING! Eliminate any leaks from the system or the appliance.

8.2.2 - Checking the gas pressure and any leaks

- 1.- Check the gas supply pressure is correct, as stated in Section 9 "Technical data";
- 2.- Make sure there are no gas leaks in the system;
- 3.- Check for gas leaks using a leak detector (bubble or similar) or an equivalent system, thoroughly checking the entire gas route from the meter to the appliance.



WARNING! Do not carry out these checks in the presence of naked flames.

8.2.3 - Checking the condition of the safety valve

- 1.- Visually check that the safety valve does not have any obstructions in the drain pipe, signs of corrosion, physical damage, water marks or signs of rust;
- 2.- In the event of obstructions in the drain pipe proceed with cleaning the pipe; in the event of other damage indicated above proceed with replacing the valve.

8 - MAINTENANCE

8.2.4 - Checking the condition of the safety and control devices

- 1.- Check any interventions of the safety and control devices by consulting the appliance diagnostics;
- 2.- Visually check that the safety and control devices show no signs of corrosion or physical damage;
- 3.- In the event of damage as indicated above, replace the devices.

8.2.5 - Checking the condition of the electrical system

- 1.- Access the internal electrical components as per Section 8.3;
- 2.- Visually check that the cables are correctly housed in the relative cable glands, and that the plug-in connections are fixed correctly and do not show signs of blackening or burns;
- 3.- In the event of damage as indicated above, replace the damaged cables.

8.2.6 - Checking the operation of the main switch

- 1.- Check that the appliance is switched off when the main switch is set to OFF and vice versa that the appliance is switched on when it is turned ON;
- 2.- In the event of a malfunction, replace the switch.

8.2.7 - Checking the correspondence of the adjusted temperatures in the domestic hot water system

- 1.- Check the correspondence between the real and set temperatures in DHW mode;
- 2.- If the temperatures do not correspond, replace the interested sensor. If the problem persists, replace the command and control board.

8.2.8 - Checking if the device is triggered in the event of gas failure

- 1.- Check that after attempts to start the appliance, with the gas shut-off valve closed, the appliance goes into lockout mode and the "Loc 1" message appears on the display;
- 2.- If the lockout message does not appear, replace the command and control board.

8.2.9 - Checking the condition of the air intake and flue exhaust ducts

- 1.- Check that the air intake and flue exhaust ducts are not obstructed, and show no signs of corrosion, physical damage, water marks or signs of rust;
- 2.- Make sure the externally assembled intake grids and flue exhaust outlets do not have any residue and are clean.

8.2.10 - Checking the ignition and detection electrodes

- 1.- Remove the burner fan unit (as shown in Section 8.4);
- 2.- Clean any material build-up from the electrodes;
- 3.- Make sure the electrodes are in the correct position as shown in Section 8.6.

8.2.11 - Checking the condition of the air vent valves

- 1.- Visually check that the air vent valves are not obstructed in the drain pipe, and show no signs of corrosion, physical damage, water marks or signs of rust;
- 2.- In the event of obstructions in the drain pipe, clean the pipe; in the event of other damage indicated above, replace the valve.

8.3 - Removing the casing and accessing the internal components

To dismantle the cover, proceed as follows (refer to Figure 8-1):

- 1.- Pull the lower cover "A" forward by about 10 mm
- 2.- Push the lower cover "A" downward;
- 3.- Unscrew screws "H";
- 4.- Pull the lower part of the front-piece "B" forward and then slide upward until it is released from the guides "C";

To access the command and control board:

- 1.- Turn the command board "D" towards the front;
- 2.- Open the command board "D" using closing mechanism "G"

To access the electrical connections board:

- 1.- Turn the command board "D" towards the front;
- 2.- Slide cover "E" out using the closing flaps "F";

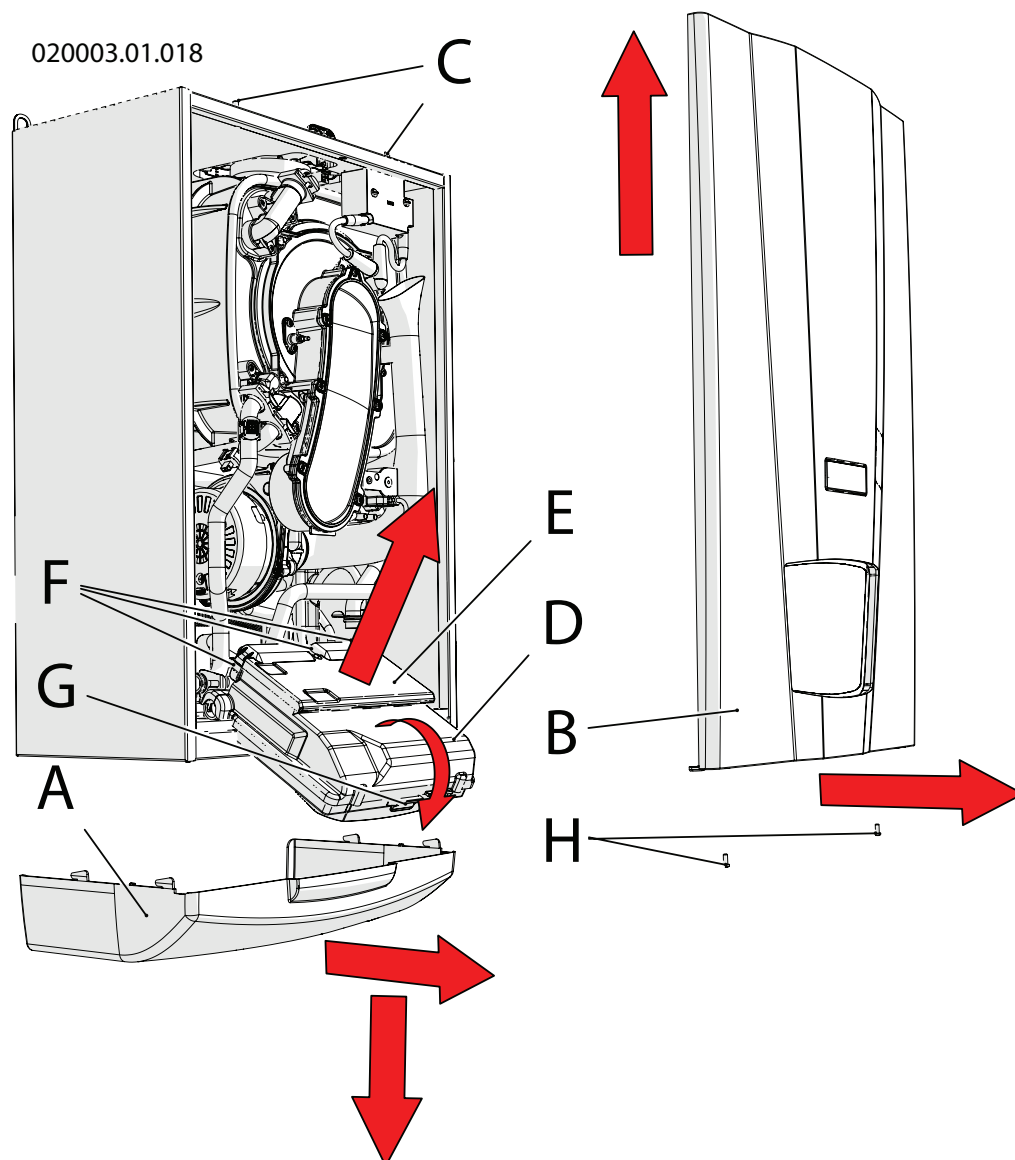

Figure 8-1 – Removing the casing and opening the command board

8 - MAINTENANCE

8.4 - Dismantling the burner fan assembly

Proceed as follows to remove the burner fan unit (refer to Figure 8-2 when not specified otherwise):

- 1.- Access the internal components following Section 8.3;
- 2.- Remove the air manifold (detail "C" in Figure 6-3) rotating it towards the outside of the boiler and then pulling it towards the right (see Figure 6-3);
- 3.- Unscrew nut "C" from valve "D";
- 4.- Disconnect cables "B" and the detection cable from the ignition and detection electrodes (details "15" and "35" in Figures 3-1, 3-2, 3-3 and 3-4);
- 5.- Unscrew the four nuts "E";
- 6.- Extract the assembly "F" as per Figure.

8.5 - Cleaning the burner and the primary heat exchanger (flue gas side)

To correctly clean the burner and heat exchanger body (flue gas side), proceed as follows (refer to Figure 8-2 when not specified otherwise):

- 1.- Access the internal components following Section 8.3;
- 2.- Remove the burner unit following Section 8.4;
- 4.- Pass a cylindrical brush with plastic bristles inside the combustion chamber
- 5.- Using a suction device, suck up the unburnt residues found inside the combustion chamber;
- 6.- With the same device, clean the surface of the burner and around the electrodes;
- 7.- Reassemble the parts in reverse order;
- 8.- Turn on the gas cock;
- 9.- Restore the electric power supply.
- 10.- Check that there are no gas leaks between the joints that were removed.

 **WARNING!** Perform the gas leak test using a soap and water solution only. The use of naked flames is prohibited.

 **WARNING!** Every time the burner and the primary heat exchanger are cleaned, check that thermal insulation elements "G" and "H" in Figure 8-2 are in good condition. If necessary, replace them along with burner gasket "L". Request the kit with code 62632006.

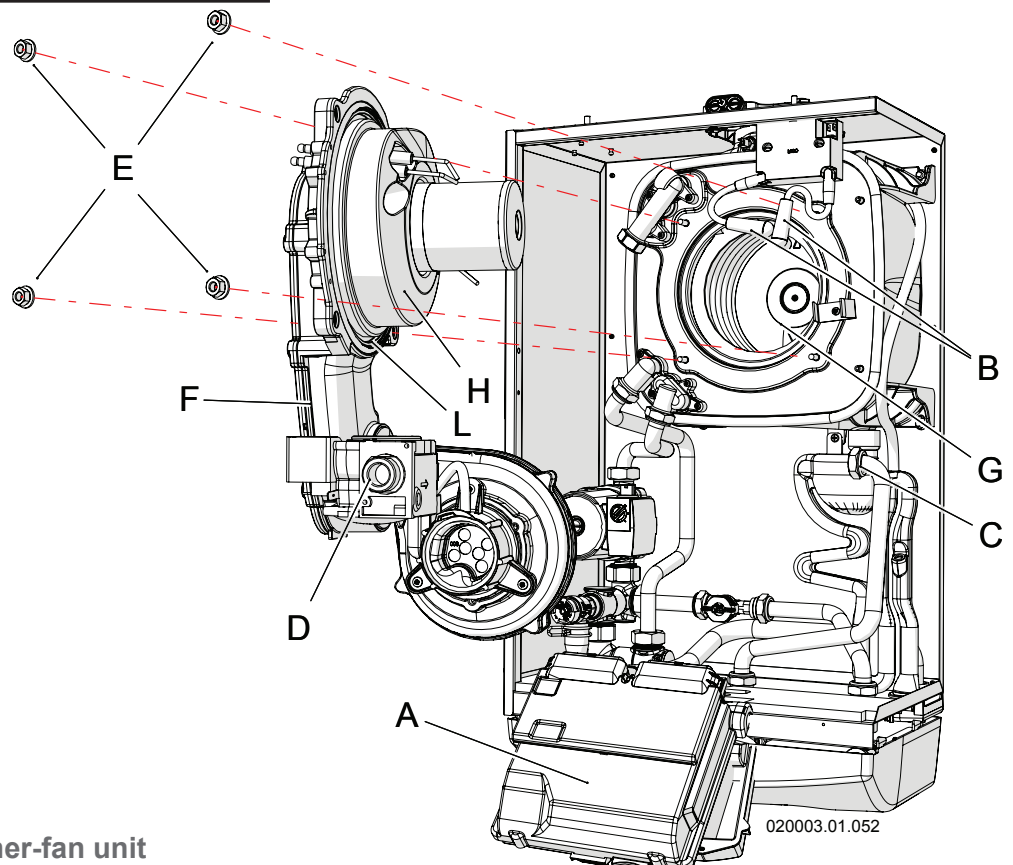
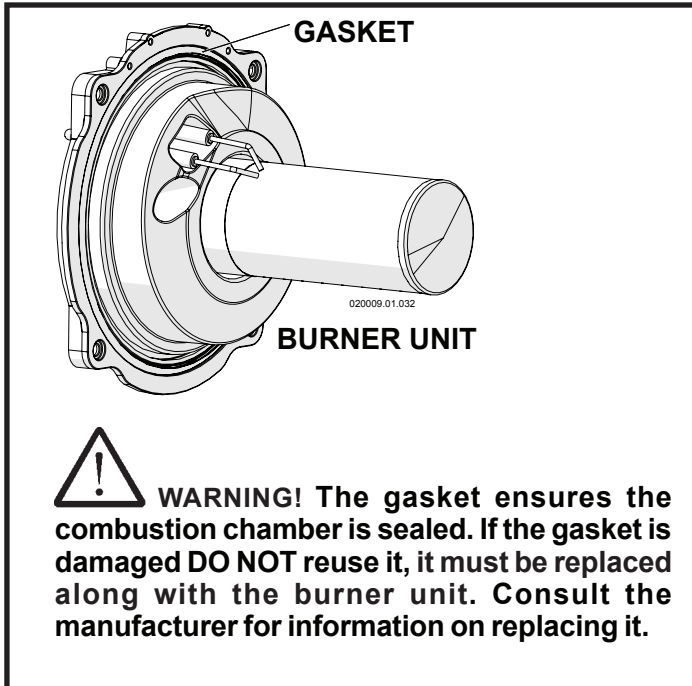

Figure 8-2 – Removing the burner-fan unit

8 - MAINTENANCE

8.6 - Correctly positioning the ignition and detection electrodes

For the appliance to work well, the electrodes must be positioned correctly (refer to Figure 8-3):

- the distance between ignition electrodes "A" and "B" must be between 2.0 and 2.5 mm;
- the distance of the ignition electrodes from the surface of the burner must be between 5 and 5.5 mm;
- the distance of the detection electrodes from the surface of the burner must be between 5.5 mm and 6.5 mm.

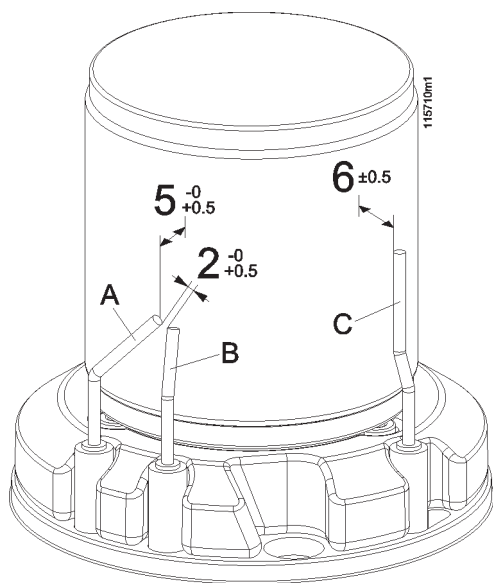

Figure 8-3 – Positioning the electrodes on the burner

8.7 - Dismantling the ignition and detection electrodes

If the ignition and/or detection electrodes need replacing, proceed as follows:

- 1.- Close the gas supply;
- 2.- Turn off electricity to the boiler;
- 3.- Access the components inside the appliance, following Section 8.3;
- 4.- Remove the burner fan unit as shown in Section 8.4;
- 5.- Disassemble the electrodes to be replaced "B" or "E" by means of screws "A" or "D" in Figure 8-4, taking care to remove seals "C" and "F";
- 6.- Assemble the new electrodes with the new gaskets "C" and "F" supplied with the replacement kits;
- 7.- Check the electrodes are in the correct position as per Section 8.6;
- 8.- Refit the rest of the components in reverse order;
- 9.- Open the gas cock;
- 10.- Connect the boiler to the electric power supply;
- 11.- Check for any gas leaks using the relevant tools.



WARNING! Perform the gas leak test using a soap and water solution only. The use of naked flames is prohibited.

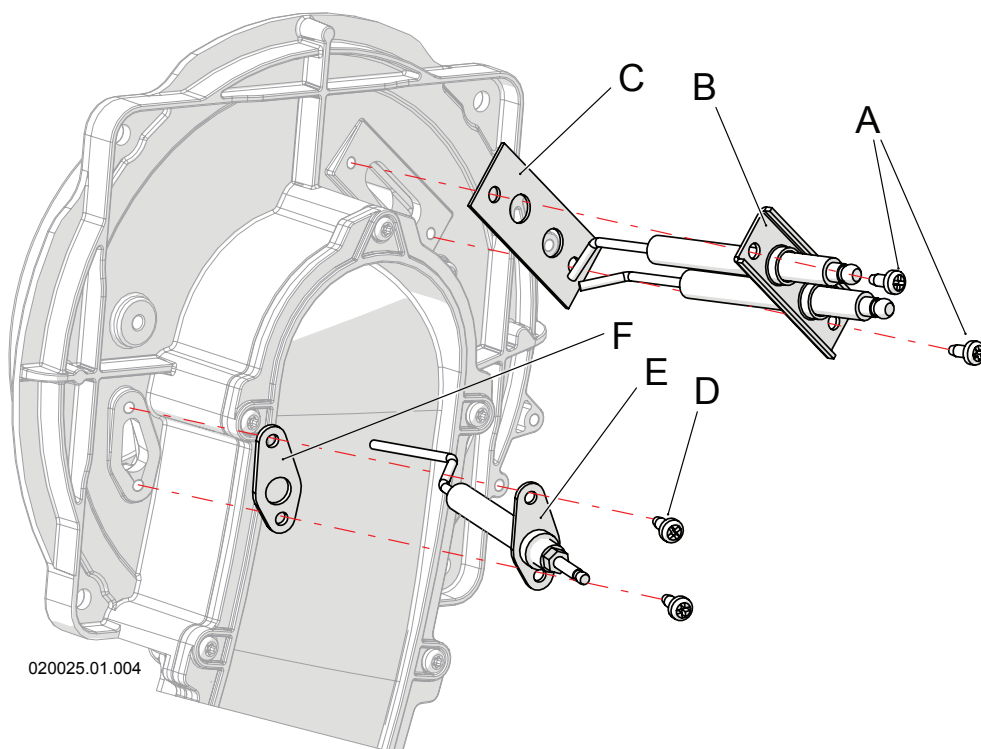

020025.01.004

Figure 8-4 – Removing the electrodes

8 - MAINTENANCE

8.8 - Dismantling and replacing the gas valve

If the gas valve needs replacing, proceed as follows:
Refer to Figure 8-5 when not specified otherwise.

- 1.- Close the gas supply;
- 2.- Turn off electricity to the boiler;
- 3.- Access the components inside the appliance, following Section 8.3;
- 4.- Detach the power cable from gas valve "D";
- 5.- Remove the gas inlet pipe via the two fittings "A" and "B";
- 6.- Remove the clamp spring "C", releasing gas valve "D";
- 7.- Slide off the gas valve "D" upwards;
- 8.- Using screws "F", remove bend "G" from the gas valve;
- 9.- Fit bend "G" on the new gas valve, taking care to position gasket "H" (supplied in the kit) correctly in the kit; the one removed previously can be disposed of;

- 10.- Fit the appliance back together by performing the operations above in reverse order;
- 11.- Open the gas cock;
- 12.- Connect the boiler to the electric power supply;
- 13.- Check for any gas leaks using the relevant tools.



WARNING! Perform the gas leak test using a soap and water solution only. The use of naked flames is prohibited.

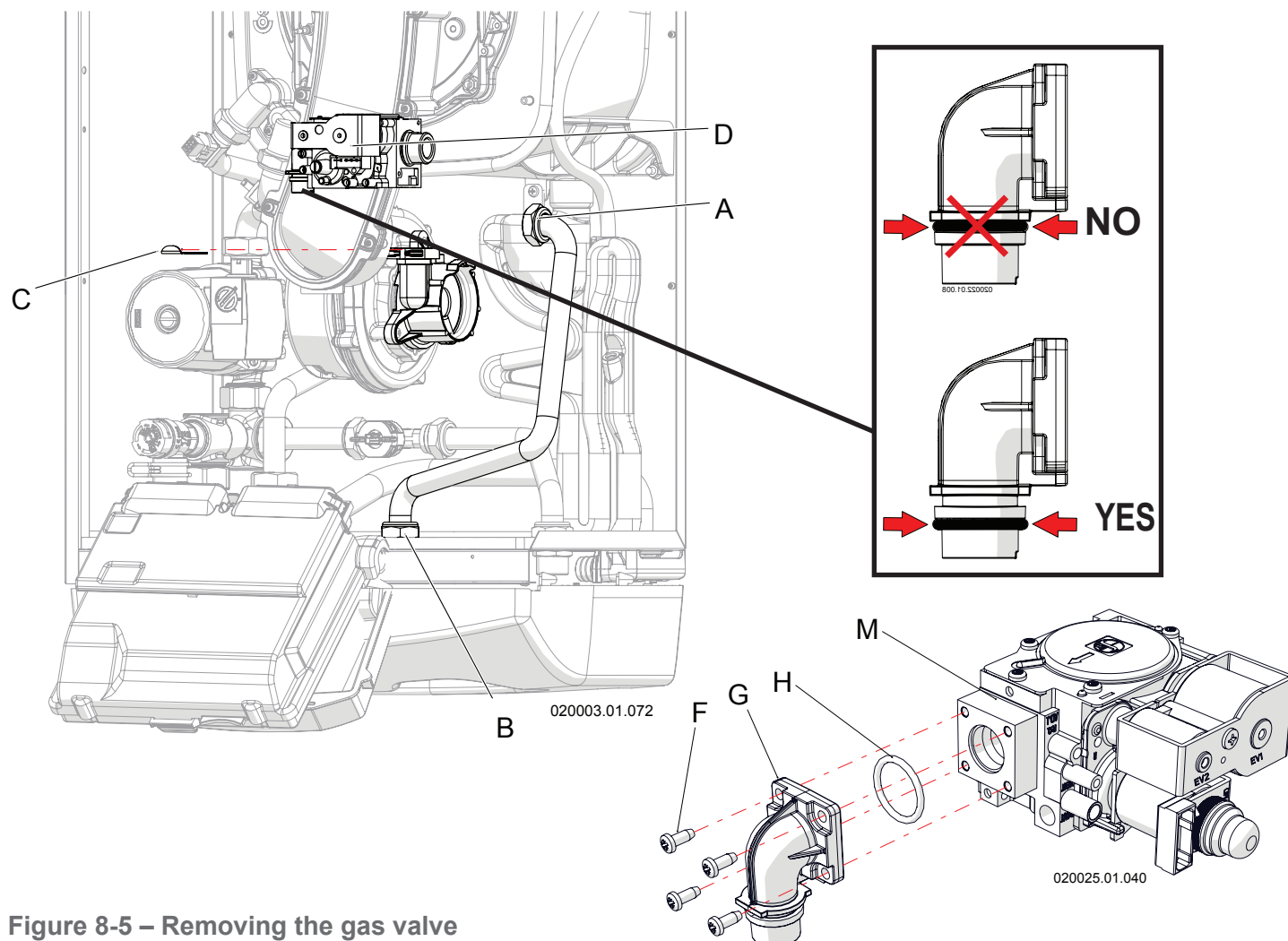

Figure 8-5 – Removing the gas valve

8.9 - Cleaning the condensate conveyor siphon

For correct cleaning of the collection siphon and conveying of the condensate produced by combustion, operate as follows (refer to the Figures 8-6, 8-7 and 8-8):

- 1.- With the boiler on, open a domestic hot water tap fully so that the burner runs at maximum power and the level of liquid inside the siphon tank "D" lowers (see Figure 8-7);
- 2.- Access the internal components as described in Section 8.3;
- 3.- Remove the burner fan unit as described in Section 8.4;
- 4.- Cover the electric system with a cloth to protect it from any water remaining inside the siphon to be dismantled;
- 5.- Slide support "B" outwards from the holding support;
- 6.- Slide tank "C" downwards carefully as it is full of condensate water which could leak out;
- 7.- Extract the siphon by moving it outwards (see Figure 8-7), taking care to disconnect the collection pipes for the water coming from the upper part of the appliance and from the air vent valve.
- 8.- Clean the decanting tank "D";
- 9.- Refit everything in reverse order, making sure gasket "E" is put back in the relevant place and that end "G" is correctly inserted into housing "H";
- 10.- Restore the level of liquid inside the siphon, following the procedure in Section 6.1.2.

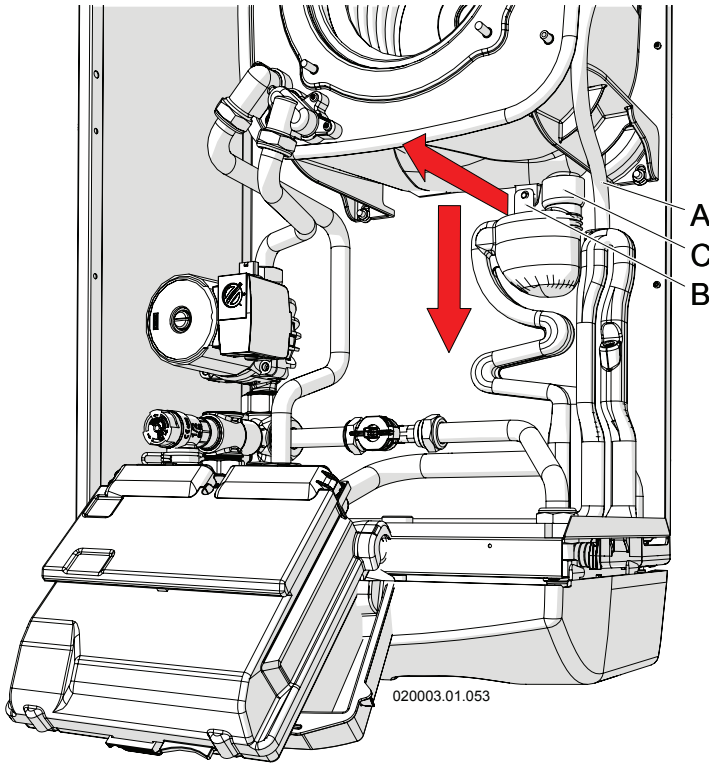

Figure 8-6 – Removing the condensate collection siphon

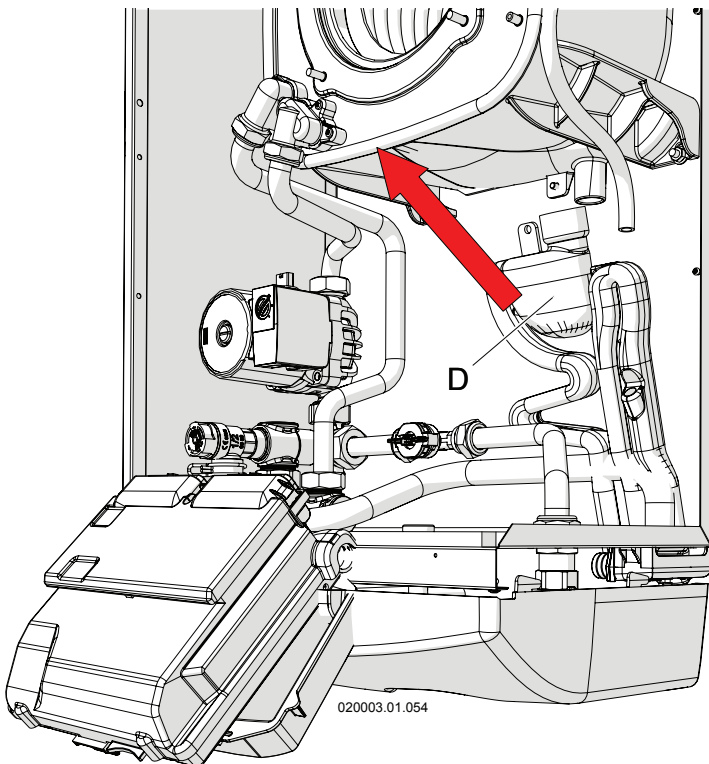

Figure 8-7 – Removing the condensate collection siphon

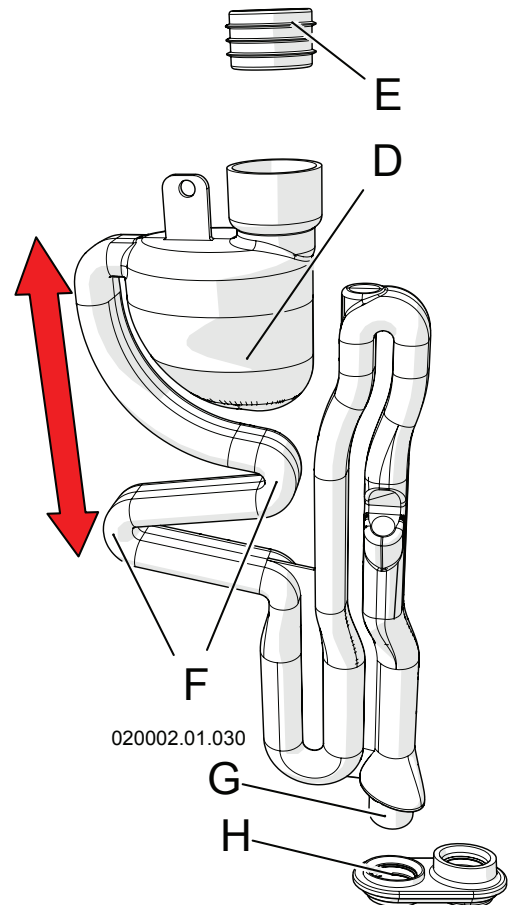

Figure 8-8 – Condensate collection siphon

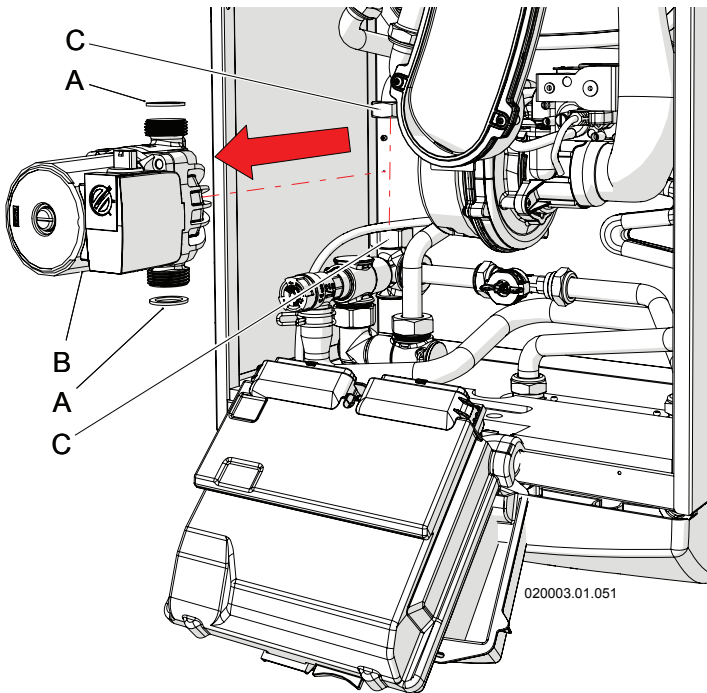

Figure 8-9 – Replacing the pump

8.10 - Replacing the pump

If the pump needs replacing, operate as follows (refer to Figure 8-9)

- 1.- Empty the water from the domestic hot water circuit, following the procedure in Section 8.13;
- 2.- Disconnect the electric power supply upstream from the appliance;
- 3.- Access the components inside the appliance, following Section 8.3;
- 3.- Disconnect the electric cables from the pump body.
- 4.- Dismantle pump "B" by unscrewing connections "C";
- 5.- Remove pump "B" by lifting out and replace it.

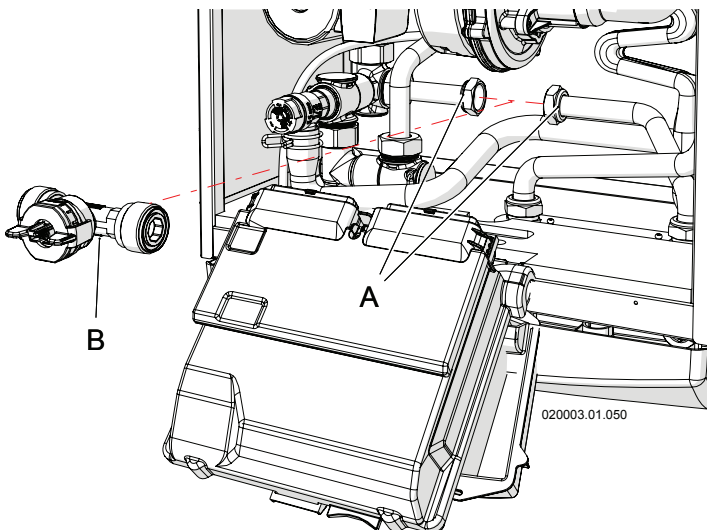

Figure 8-10 - Removing the flow meter

8.11 - Removing the domestic hot water flow meter

Proceed as follows, referring to Figure 8-10:

- 1.- Empty the domestic hot water circuit, following the procedure in Section 8.13;
- 2.- Disconnect the electric power supply upstream from the appliance;
- 3.- Access the components inside the appliance, following Section 8.3;
- 4.- Disconnect the cables from flow meter "B";
- 5.- Unscrew discs "A" taking care that residual water in the pipes does not get to the control panel;
- 6.- slide flow meter "B" upwards and replace it.

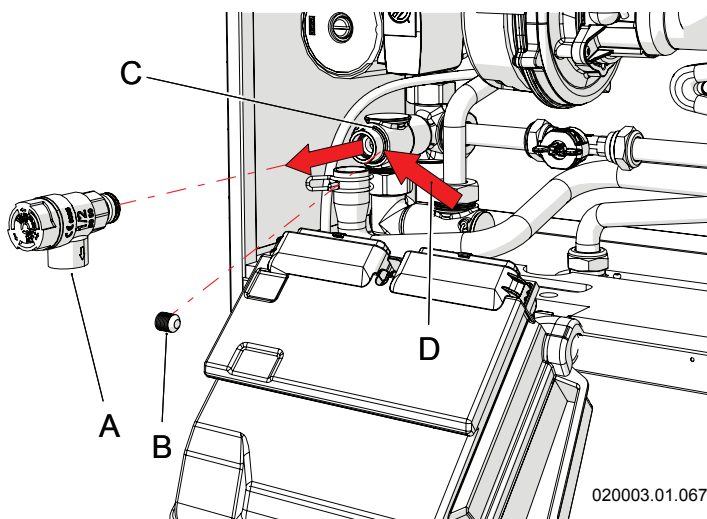

Figure 8-11 – Removing the safety valve

8.12 - Removing the safety valve

The safety valve (detail "A" in Figure 8-11) protects the appliance against overpressure. If it needs to be replaced, proceed as follows (refer to Figure 8-11):

- 1.- Empty the domestic hot water circuit, following the procedure in Section 8.13;
- 2.- Access the components inside the appliance, following Section 8.3;
- 3.- Disconnect the exhaust pipe from the valve to be replaced "A";
- 4.- Unscrew the side nut "B" from the hydraulic unit, thus freeing valve "A";
- 5.- Remove safety valve "A" and replace it.

8.13 - Emptying the appliance on the domestic hot water side

To empty the appliance, proceed as follows:

- 1.- Close taps "10" and "3" shown in Figure 5-9;
- 2.- Connect drainage pipes to taps "4" in Figure 5-9;
- 3.- Open taps "4" in fig. 5-9;
- 4.- If there is a risk of frost, it is advisable to blow compressed air (maximum 3 bar) into a tap, in order to evacuate all the water contained inside the heat exchanger.

8.14 - Minimum and maximum power

To force operation at the appliance's minimum, maximum, set or ignition power, proceed as follows:

- 1.- Open one or more hot water taps to deliver all the boiler's power;



WARNING! When forcing the delivery temperature, it automatically sets itself at 93°C to dispose of as much of the heat generated by the boiler as possible. Check whether the system downstream of the appliance can support this temperature.

- 2.- Access parameter `0200`, which can be viewed and changed from the "Installer profile" (see Section 7.7);
- 3.- Set parameter `0200` to the following value:
 - a) `L0` to force the boiler to minimum power;
 - b) `197` to force the boiler to ignition power;
 - c) `H1` to force the boiler to maximum power;
 - d) `rE9` to force the boiler to the maximum power, as set by parameter `2014`.
- 4.- To end forcing, set parameter `0200` to `OFF` and press the RESET key.



WARNING! If during forcing, the power supplied by the boiler is much higher than the power absorbed by the system, the boiler switches off continuously to reach the maximum temperature allowed (93°C).

☞ Forcing lasts 10 minutes, after which the appliance returns to normal operating conditions.

8.15 - Checking the ionisation current

In any operating status, including during checks on the minimum and maximum power stated in Section 8.14, the

ionisation current value can be consulted at parameter `1008` from any profile.

This value must be between 4 and 8 uA (microampere).

8.16 - Water temperature measurement sensors

Various temperature sensors are positioned on the heat exchanger body. The electrical resistance between the two sensor contacts must correspond to that shown in Figure 8-12.

The temperature sensors are: `1001`, `1002`, `1005`, `1006` and `1007`. Check their positioning in Figures 3-1, 3-3 and 3-4.

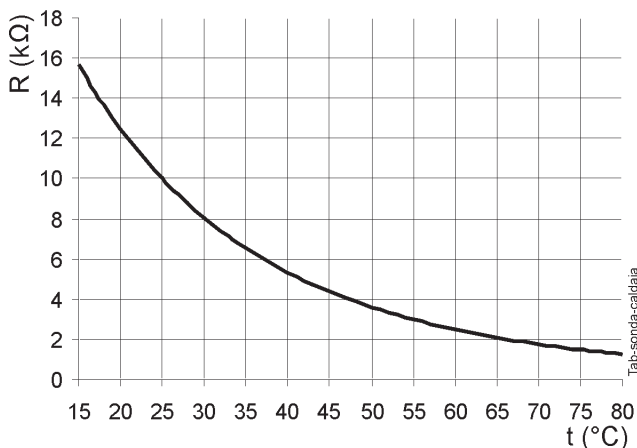
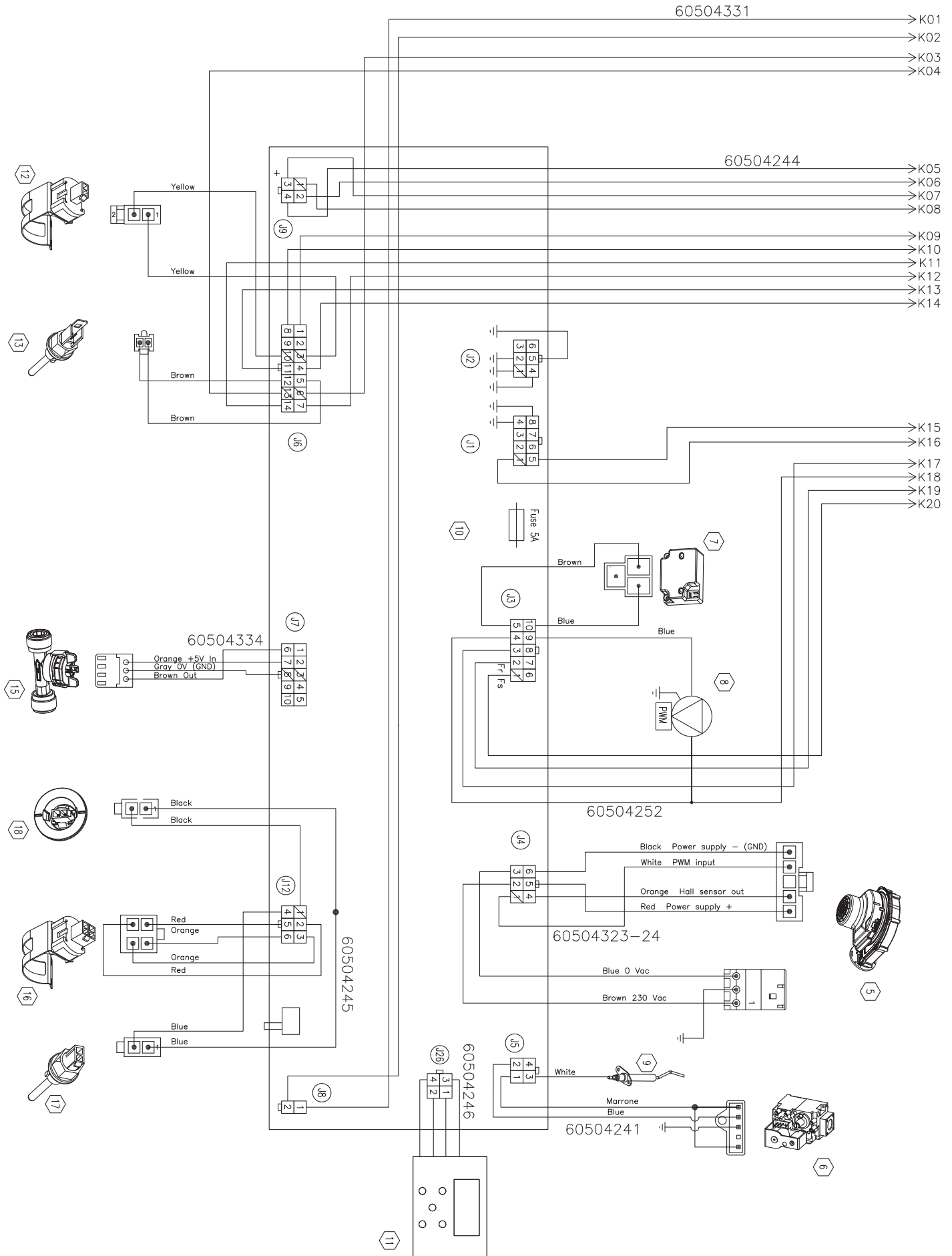

Figure 8-12 - Water sensors curve

8.17 - Wiring diagram



104311_m8

Figure 8-13 – Wiring diagram

8 - MAINTENANCE

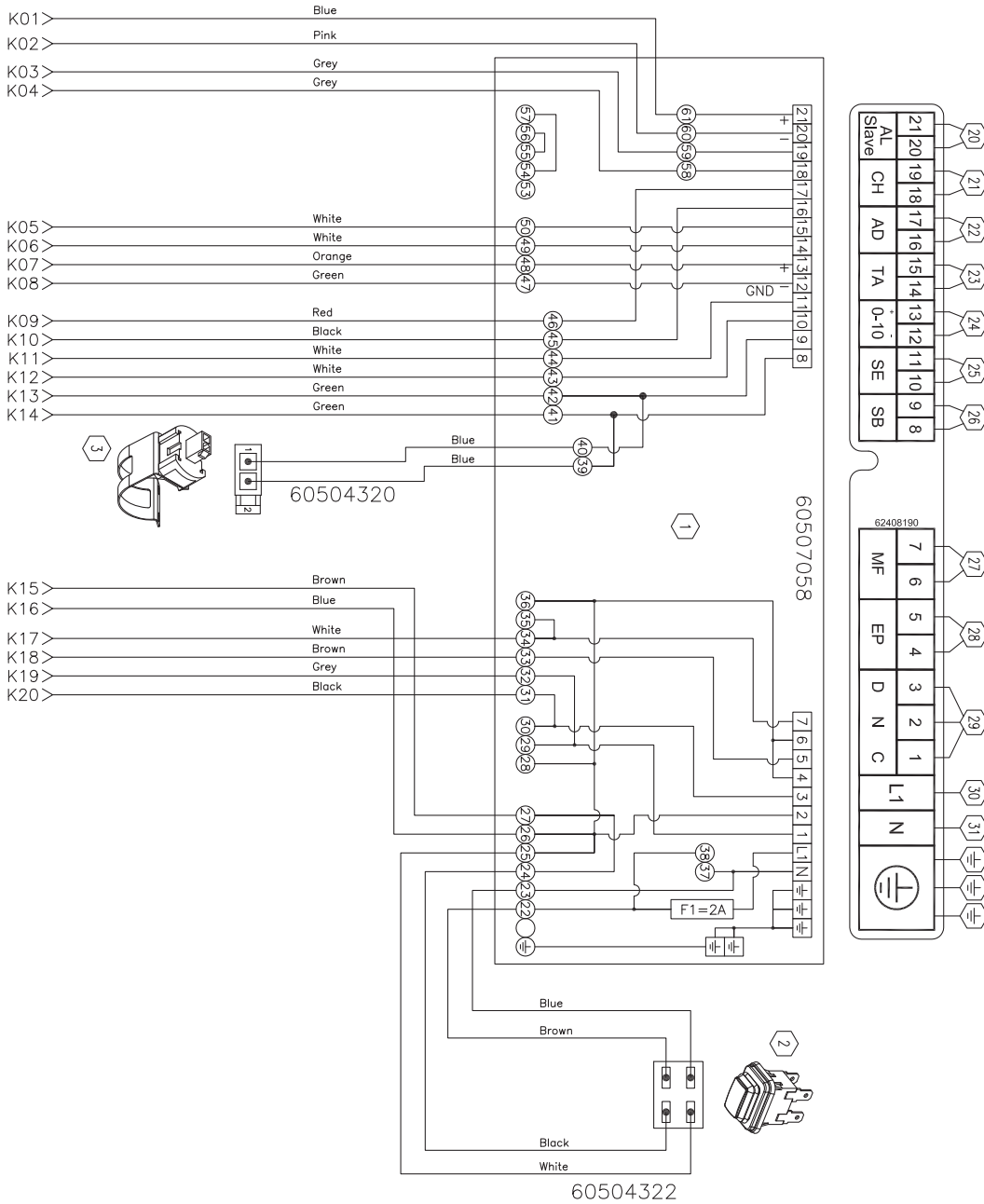

1 - Electric connections board

2 - Master switch

3 - D.H.W. sensor (1002)

4 - -----

5 - Fan

6 - Gas valve

7 - Spark generator

8 - Pump

9 - Ionisation electrode

10 - Command and control board

11 - Display

12 - Cold water inlet temperature sensor (1007)

13 - Flue gas temperature sensor (1006)

14 - -----

15 - Water flow rate sensor

16 - Dual domestic hot water outlet temperature

sensor (1001 and 1005)

17 - Flue gas temperature fuse

18 - Primary heat exchanger temperature fuse

19 - -----

20 - Not used

21 - Not used

22 - Not used

23 - CR04 remote control (if present)

24 - 0-10 VDC communication

25 - Not used

26 - Indirect water heater sensor (if present)

27 - Alarm output

28 - External pump (if present)

29 - Not used

30 - Line

31 - Neutral

→ K1 K1 →

104111m0_esejplio

WARNING! To facilitate consultation, K references are given in the wiring diagram followed by a number (see example above). This is to identify the correct follow-on of the cables on the next page.

9 - TECHNICAL DATA

AGUADENS TECHNICAL DATA		UM	16	22	37
Type (Type of flue gas exhaust/air intake)			B23; B23P; C13; C33; C43; C53; C63; C83; C93		
Category			I2H3P	I2H3P	I2H3P
EU type approval certificate (PIN)			0476CQ1097	0476CQ1097	0476CQ1097
Max. heat input "Qn" PCI (PCS)		kW	25.5 (28.3)	32.0 (35.5)	57.8 (64.2)
Min. heat input "Qm" PCI (PCS)		kW	3.2 (3.6)	6.0 (6.7)	12.0 (13.3)
Max. useful output power "Pn"		kW	27.0	33.5	60.9
Efficiency at max effective power PCI (PCS)		%	105.7 (95.2)	104.7 (94.3)	105.3 (94.9)
Min. useful output power "Pm"		kW	3.30	6.14	12.85
Efficiency at minimum effective power PCI (PCS)		%	103.0 (92.8)	102.4 (92.3)	107.1 (96.5)
Gas flow rate	G20	m ³ /h	2.70	3.38	6.11
	G25	m ³ /h	3.16	3.94	7.11
	G30	kg/h	2.01	2.52	4.55
	G31	kg/h	1.98	2.48	4.49
Gas supply pressure	G20	mbar	20	20	20
	G25	mbar	25	25	25
	G30	mbar	30	30	30
	G31	mbar	37	37	37
Gas supply minimum pressure	G20	mbar	10	10	10
	G25	mbar	10	10	10
	G30	mbar	10	10	10
	G31	mbar	10	10	10
Gas supply maximum pressure	G20	mbar	45	45	45
	G25	mbar	45	45	45
	G30	mbar	45	45	45
	G31	mbar	45	45	45
DHW temperature adjustment field		°C	40-60 (75)	40-60 (75)	40-60 (75)
DHW maximum flow rate (Δt 30°C)		l/min	12.9	16.0	29.1
Maximum DHW circuit pressure "Pw"		bar	9,5	9,5	9,5
Minimum DHW circuit pressure		bar	1	1	1
Minimum water flow rate		l/min	2.5	2.5	2.5
Rated power supply voltage		V	230	230	230
Rated power supply frequency		Hz	50	50	50
Total absorbed electrical power		W	165	165	235
Pump absorbed electrical power		W	95	95	95
Burner absorbed electrical power		W	70	70	140
Electrical protection rating			IPX4D	IPX4D	IPX4D
Flue gas exhaust pipe / air intake diameter (split)		mm	80	80	80
Flue gas exhaust pipe max. length (split) (80) or (50)		m	(20) or (7*)	(12.5) or (3*)	10
Air intake pipe max. length (split) (80) or (50)		m	(20) or (7*)	(12.5) or (3*)	10
Flue gas pipe diameter (coaxial)		mm	60/100	60/100	80/125
Flue gas pipe max. length (coaxial)		m	10	10	10
Equivalent length of a bend		m	45° bend = 0.5 m, 90° bend = 1 m		
Weighted CO (0% O ₂) (EN26:2015) PCS		G20 ppm	11	19	10
Weighted NO _x (0% O ₂) (EN26:2015) PCS	G20	mg/kWh	20	29	16
	G25	mg/kWh	20	30	16
	G30	mg/kWh	26	38	20
	G31	mg/kWh	24	34	20
CO ₂ (%) at minimum/maximum power	G20	%	8.5/9.0	8.5/9.0	8.3/8.7
	G25	%	8.5/9.0	8.5/9.0	8.3/8.7
	G30	%	9.5/10.5	9.5/10.5	9.5/10.1
	G31	%	9.5/10.5	10.0/10.5	9.5/10.1
O ₂ (%) at minimum/maximum power	G20	%	5.8/4.9	5.8/4.9	6.1/5.4
	G25	%	5.4/4.5	5.4/4.5	5.8/5.0
	G30	%	6.7/5.2	6.7/5.2	6.8/5.9
	G31	%	6.4/4.9	5.6/4.9	6.4/5.5

9 - TECHNICAL DATA

AGUADENS TECHNICAL DATA	UM	16	22	37
Maximum temperature of flue gases at boiler outlet	°C	80	80	80
Mass flow of flue gas at maximum power	g/s	11.6	14.6	27.2
Mass flow of flue gas at minimum power	g/s	1.5	3.4	5.9
Head available at exhaust	Pa	90	90	90
Maximum flue gas temperature for overheating	°C	95	95	95
Max. negative pressure allowed in the flue gas exhaust/air intake system	Pa	90	90	90
Condensate maximum flow rate	l/h	3.2	4.0	7.2
Condensate average acidity	pH	4	4	4
Operating room temperature	°C	0.5 ; +50	0.5 ; +50	0.5 ; +50
Weight of boiler	kg	36	36	48

* In these conditions, the appliance power is reduced by 10%

10 - PRODUCT FICHE

(a) Name or brand of supplier			COSMOGAS				
(b) Supplier's identifying model number			AGUADENS				
			16	22	37		
(c) Declared load profile			XL	XXL	XXL		
(d) Class of energy efficiency			A	A	A		
(e) Domestic hot water production efficiency	η_{wh}	%	90.0	91.6	87.9		
(f) Daily consumption of electrical energy	Qelec	kWh	0.276	0.249	0.280		
(f) Annual consumption of electrical energy	AEC	kWh	61	55	61		
(f) Daily consumption of fuel	Qfuel	kWh	20.917	26.160	27.205		
(f) Annual consumption of fuel	AFC	GJ	16	21	22		
(g) Other load profile			-	-	-		
(g) Domestic hot water production efficiency*			-	-	-		
(g) Daily consumption of electrical energy *			-	-	-		
(g) Annual consumption of electrical energy *			-	-	-		
(g) Daily consumption of fuel *			-	-	-		
(g) Annual consumption of fuel *			-	-	-		
(h) Water heater thermostat temperature adjustment			57	56	56		
(i) Level of sound power inside			LWA	dB	51	52	58
(j) The water heater can only operate during slack times			NO	NO	NO		
(k) any eventual specific precautions to take during assembly, installation or maintenance of the water heater.			Read the instructions for the installation, use and maintenance of the product.				
(l) Smart control factor			N/A	N/A	N/A		
Emissions of nitrogen oxides			NOx	mg/kWh	20	29	16

In agreement with European Ruling (EU) No 812/2013 and No 814/2013;

* Related to other load profile (g);

N/A = Not Applicable;

11 - COMMAND MENU DIAGRAM

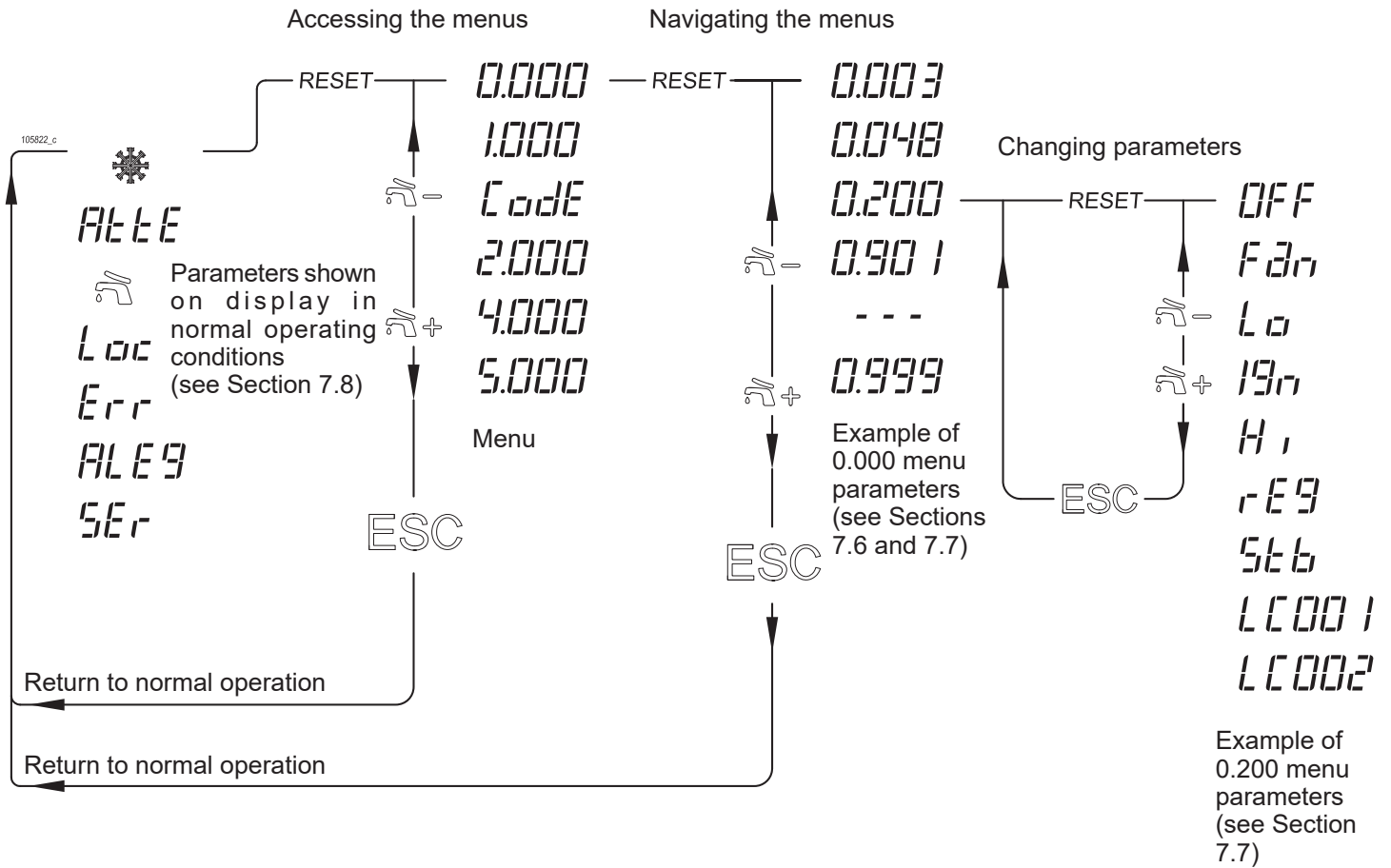

Figure 10-1 - Command menu diagram

The undersigned CEO of the company **COSMOGAS S.r.l.**, with registered office in Via L. Da Vinci no. 16 - 47014 Meldola (FC) Italy,

DECLARES

under its own responsibility that the central heating boiler:

SERIAL No.	_____
MODEL	_____
PRODUCTION DATA	_____

subject of this declaration is in compliance with the **EU** Type Test Certificate, issued by the notified body n° 0476 (Kiwa Cermet Italia SpA), whose data (PIN) are given in the table shown in the “Technical Data” section of this manual and fulfils the requirements of the EU Regulation on Gas Appliances (**2016/426/UE**) and the Reg. **UE 814/2013** applying the standards **EN 26:2015** and the Low Voltage Directive (**2014/35/UE**) applying the standards **EN 60335-1:2012+A11:2014** and **EN 60335-2-102:2016** and the Electro Magnetic Compatibility Directive (**2014/30/UE**) applying the standards **EN 55014-1:2019** and **EN 55014-2:2016**, Energy labeling regulation (**2017/1369/UE**), Eco-friendly design directive (**2009/125/CE**), Directive on the use of dangerous substances (**2011/65/UE**).

Monitoring of the product was carried out by the notified body No. 0476 according to form C2.

This declaration is issued as stipulated by the aforementioned directives.

The serial number corrisponde to the warranty number.

Meldola (FC) ITALY.



Alessandrini Arturo
Sole Director



COSMOGAS s.r.l.
Via L. da Vinci 16 - 47014
MELDOLA (FC) ITALY
info@cosmogas.com
www.cosmogas.com