

Hoval CompactGas

Gas boiler

- High-efficiency boiler to EN 14394 for firing of gas
- Downstream heating surface made of **aluFer®** bounded pipe
- Boiler completely welded
- Also suitable for LowNOx burner with extremely low pollutant emissions
- Insulation at the boiler body 80 mm mineral wool mat and special fabric
- Boiler completely cased with steel plate, red powder coated
- Accessible cover from checkered sheet.
- Flue gas outlet, heating flow and heating return connections to the top incl. counter flanges, screws and seals
- Condensate trap

Optional

- Control panel with boiler controller and regulators in different designs
- Free-standing calorifier see Calorifiers
- Boiler door swivels to the left

Delivery

- Boiler, thermal insulation, casing and condensate trap are supplied separately

On site

- Installation of the thermal insulation, casing and condensate trap



Model series

CompactGas type	Nominal heat output kW
(700)	250-700
(1000)	300-1000
(1400)	420-1400
(1800)	540-1800
(2200)	660-2200
(2800)	840-2800
(3500)	1050-3500
(4200)	1260-4200

Boiler permissions

CompactGas (700-2800)
CE product ID No.: CE 0085 BT0376
according to EU Gas Equipment Directive (EU/2016/426)

The boiler complies with the PED
Pressure Equipment Directive 2014/68/EU

Boiler controller with TopTronic® E/E13.4 controller

- Max. operating temperature 90 °C

Control panel

- Colour touchscreen 4.3 inch
- Heat generator blocking switch for interrupting operation
- Fault signalling lamp

TopTronic® E control module

- Simple, intuitive operating concept
- Display of the most important operating statuses
- Configurable start screen
- Operating mode selection
- Configurable day and week programmes
- Operation of all connected Hoval CAN bus modules
- Commissioning wizard
- Service and maintenance function
- Fault message management
- Analysis function
- Weather display (with online HovalConnect)
- Adaptation of the heating strategy based on the weather forecast (with HovalConnect)

TopTronic® E basic module heat generator (TTE-WEZ)

- Control functions integrated for
 - 1 heating/cooling circuit with mixer
 - 1 heating/cooling circuit without mixer
 - 1 hot water charging circuit
 - bivalent and cascade management
- Outdoor sensor
- Immersion sensor (calorifier sensor)
- Contact sensor (flow temperature sensor)
- Rast-5 basic plug set

The supplementary plug set must be ordered in order to use expanded controller functions.

Options for TopTronic® E controller

- Can be expanded by max. 1 module expansion:
 - module expansion heating circuit or
 - module expansion heat accounting or
 - module expansion universal
- Can be networked with a total of up to 16 controller modules:
 - heating circuit/hot water module
 - solar module
 - buffer module
 - measuring module

Number of modules that can be additionally installed in the electrical box:

- 1 module expansion and 2 controller modules **or**
- 1 controller module and 2 module expansions **or**
- 3 controller modules

Notice

Max. 1 module expansion can be connected to the basic module heat generator (TTE-WEZ)!

Further information about the TopTronic® E see "Controls"

Delivery

- Boiler controller separately delivered

On site

- Mounting of the boiler controller at the boiler left or right side

Boiler controller with TopTronic® E/E13.5 controller

- Max. operating temperature 105 °C

- Design as boiler controller TopTronic® E/E13.4, but:
- Safety temperature limiter 120 °C

Delivery

- Boiler controller separately delivered

On site

- Mounting of the boiler controller at the boiler left or right side

Control panel with thermostat T 2.2

- Max. operating temperature 90 °C

- For systems without TopTronic® E controller
- For direct 2-stage burner control, requirement starting from external calorifier or heater instruction is possible.
- Main switch "I/O"
- Safety temperature limiter 110 °C
- Selector switch burner load
- Switch summer/winter
- 3 boiler temperature regulators 30-90 °C
 - temperature regulator for base load heating
 - temperature regulator for full load heating
 - temperature regulator for calorifier
- Boiler and burner breakdown lamp
- Plug connection for burner

Optional

- 2 running time meters integrated
- 2 burner running time meters and pulse counters integrated
- Flue gas thermometer, 4.5 m capillary tube

Delivery

- Boiler controller separately delivered

On site

- Mounting of the boiler controller at the boiler left or right side

Control panel with thermostat T 0.2

- Max. operating temperature 105 °C

- For external control
- For systems without TopTronic® E controller
- For special control function
- Main switch "I/O"
- Safety temperature limiter 120 °C,
- 3 boiler temperature regulators 50-105 °C
 - temperature regulator for base load heating
 - temperature regulator for full load heating
 - temperature regulator for calorifier
- Without burner plug connection

Optional

- 2 running time meters integrated
- 2 burner running time meters and pulse counters integrated
- Flue gas thermometer, 4.5 m capillary tube

Delivery

- Boiler controller separately delivered

On site

- Mounting of the boiler controller at the boiler left or right side

Gas boiler



Hoval CompactGas (700-4200)

High-efficiency boiler made of steel for gas firing, without boiler controller

Design: delivery complete

- Boiler, thermal insulation, casing and condensate trap are supplied separately

CompactGas type	Nominal heat output kW	Operating pressure bar
(700)	250-700	6
(1000)	300-1000	6
(1400)	420-1400	6
(1800)	540-1800	6
(2200)	660-2200	6
(2800)	840-2800	10
(3500)	1050-3500	10
(4200)	1260-4200	10

Part No.

7013 351
7013 352
7013 353
7013 354
7013 355
7013 356
7014 800
7014 321

The minimum boiler operating temperature and the minimum boiler return temperature must imperatively be observed (see technical data).
A return temperature control must be provided!

The condensate trap must imperatively be mounted on the flue gas outlet of the boiler!



Blind flange made of steel
incl. setscrews and gasket
for CompactGas (700)
for CompactGas (1000)
for CompactGas (1400-2800)
for CompactGas (3500,4200)

6002 192
6030 026
6002 156
6043 944



Intermediate flange drilled to match burner
made of steel incl. setscrews and gasket to
CompactGas (700)
CompactGas (1000)
CompactGas (1400-2800)

6017 595
6017 593
6017 594

Boiler controllers with thermostats



Boiler controller T 2.2

- Operating temperature max. 90 °C
- For systems without TopTronic® E controller.
- For direct 2-stage burner control, incl. plug connection for burner requirement starting from external calorifier or heater instruction is possible.
 - without burner running time meter and pulse counter
 - incl. 2 burner running time meters integrated
 - incl. 2 burner running time meters and pulse counters integrated
- for mounting on heat generator side right (standard) or left (configuration on request). Specify mounting variant in purchase order.

6015 017

6015 477

6015 478



Boiler controller T 0.2

- Operating temperature max. 105 °C
- For external switching command
- For systems without TopTronic® E controller.
- For special control function without burner plug connection
 - without burner running time meter and pulse counter
 - incl. 2 burner running time meters integrated
 - incl. 2 burner running time meters and pulse counters integrated
- for mounting on heat generator side right (standard) or left (configuration on request). Specify mounting variant in purchase order.

6015 016

6015 475

6015 476

Accessories to boiler controllers with thermostat

Flue gas thermometer
4 m, capillary tube

241 149

**Boiler controller
with TopTronic® E control**



**Boiler control E13.4
TopTronic® E**

for mounting on heat generator side right (standard) or left (configuration on request). Specify mounting variant in purchase order. Operating temperature max. 90 °C. Control function integrated for

- 1 heating circuit with mixer
- 1 heating circuit without mixer
- 1 DHW charging circuit

Heat generator management
Additional heat generator management
Cascade management
Optionally expandable by max. 1 module expansion:

- Module expansion heating circuit or
- Module expansion universal

Optionally networkable with up to 16 controller modules (incl. solar module).
Max. 3 additional controller modules can be installed in control box.

Consisting of:
electrical box,
control panel,
TopTronic® E control module,
TopTronic® E basic module heat generator,
oil automatic function device OFA-200,
safety temperature limiter,
burner cable cpl. 2-stage, L = 5.0 m,
1x outdoor sensor AF/2P/K,
1x immersion sensor TF/2P/5/6T/S1, L = 5.0 m
1 contact sensor ALF/2P/4/T/S1, L = 4.0 m

Notice

The electrical connection for each external burner must be clarified separately.

Part No.

6040 236



Boiler controller TopTronic® E / E13.5

for installation on the right (standard installation) or left side (configuration on request) of the heat generator. Specify installation variant in purchase order.

- Max. operating temperature 105 °C.

Version as boiler controller TopTronic® E / E13.4

Notice

The electrical connection for each external burner must be clarified separately.

6040 237

TopTronic® E module expansions
for TopTronic® E basic module heat generator

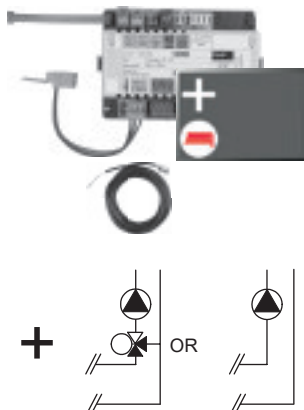

TopTronic® E module expansion heating circuit TTE-FE HK

Expansion to the inputs and outputs of the basic module heat generator or the heating circuit/domestic hot water module for implementing the following functions:

- 1 heating/cooling circuit w/o mixer or
- 1 heating/cooling circuit with mixer

Consisting of:

- Fitting accessories
- 1 contact sensor

ALF/2P/4/T L = 4.0 m

- Basic plug set FE module

Notice

The supplementary plug set may have to be ordered to implement functions differing from the standard!

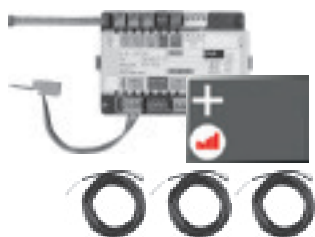

TopTronic® E module expansion heating circuit incl. energy balancing TTE-FE HK-EBZ

Expansion to the inputs and outputs of the basic module heat generator or the heating circuit/domestic hot water module for implementing the following functions:

- 1 heating/cooling circuit w/o mixer or
- 1 heating/cooling circuit with mixer incl. energy balancing in each case

Consisting of:

- Fitting accessories
- 3 contact sensors

ALF/2P/4/T L = 4.0 m

- Plug set FE module

Notice

Suitable flow rate sensors (pulse sensors) must be provided on site.

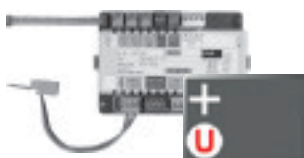

TopTronic® E module expansion Universal TTE-FE UNI

Expansion to the inputs and outputs of a controller module (basic module heat generator, heating circuit/domestic hot water module, solar module, buffer module) for implementing various functions

Consisting of:

- Fitting accessories
- Plug set FE module

Further information

see "Controls" - "Hoval TopTronic® E module expansions" chapter

Notice

Refer to the Hoval System Technology to find which functions and hydraulic arrangements can be implemented.

Part No.

6034 576

6037 062

6034 575

Accessories for TopTronic® E



Supplementary plug set

for basic module heat generator (TTE-WEZ)
for controller modules and module expansion
TTE-FE HK

6034 499
6034 503



TopTronic® E controller modules

TTE-HK/WW TopTronic® E heating circuit/
hot water module
TTE-SOL TopTronic® E solar module
TTE-PS TopTronic® E buffer module
TTE-MWA TopTronic® E measuring module

6034 571
6037 058
6037 057
6034 574



TopTronic® E room control modules

TTE-RBM TopTronic® E room control modules
easy white
comfort white
comfort black

6037 071
6037 069
6037 070



Enhanced language package TopTronic® E

one SD card required per control module
Consisting of the following languages:
HU, CS, SL, RO, PL, TR, ES, HR, SR, JA, DA

6039 253



HovalConnect

HovalConnect LAN
HovalConnect WLAN

6049 496
6049 498

TopTronic® E interface modules

GLT module 0-10 V
HovalConnect Modbus
HovalConnect KNX

6034 578
6049 501
6049 593



TopTronic® E wall casing

WG-190 Wall casing small
WG-360 Wall casing medium
WG-360 BM Wall casing medium with
control module cut-out
WG-510 Wall casing large
WG-510 BM Wall casing large with
control module cut-out

6052 983
6052 984
6052 985
6052 986
6052 987



TopTronic® E sensors

AF/2P/K Outdoor sensor
TF/2P/5/6T Immersion sensor, L = 5.0 m
ALF/2P/4/T Contact sensor, L = 4.0 m
TF/1.1P/2.5S/6T Collector sensor, L = 2.5 m

2055 889
2055 888
2056 775
2056 776



System housing

System housing 182 mm
System housing 254 mm

6038 551
6038 552



Bivalent switch

2061 826

Further information
see "Controls"

Part No.



Flow temperature guard

for underfloor heating system (1 guard per heating circuit) 15-95 °C, switching difference 6 K, capillary tube max. 700 mm setting (visible from the outside) under the housing cover

Clamp-on thermostat RAK-TW1000.S
Thermostat with strap, without cable and plug

242 902

Kit clamp-on thermostat RAK-TW1000.S
Thermostat with strap,
enclosed cable (4 m) and plug

6033 745

Immersion thermostat RAK-TW1000.S SB 150
Thermostat with pocket ½" - depth of immersion 150 mm, brass nickel-plated

6010 082



Vibration elements for boiler socket

For sound and vibration absorption.
Made of rubber. Cross-section 80/50 mm.

Delivery

Set of 4 vibration elements per boiler,
mounted under the boiler socket

To CompactGas type	Size	Length mm
(700,1000)	L400 (4 pieces)	400
(1400)	L500 (4 pieces)	500
(1800-2800)	L800 (4 pieces)	800
(3500,4200)	L800 (4 pieces)	800

Part No.

Service



Commissioning

Commissioning by works service or Hoval trained authorised serviceman/company is condition for warranty.

For commissioning and other services please contact your Hoval sales office.

Part No.

Part No.

CompactGas (700-1800)

Type		(700)	(1000)	(1400)	(1800)
• Nominal heat output at 80/60 °C	kW	700	1000	1400	1800
• Nominal heat output min./max. at 80/60 °C	kW	250-700	300-1000	420-1400	540-1800
• Max. firing output	kW	725	1037	1458	1865
• Boiler operating temperature ¹⁾ max.	°C	105	105	105	105
• Boiler operating temperature min.	°C	75	75	75	75
• Boiler return temperature min.	°C	35	35	35	35
• Safety temperature limiter setting (water side) ²⁾	°C	120	120	120	120
• Operating/test pressure	bar	6/9	6/9	6/9	6/9
• Boiler efficiency at 80/60 °C in full-load operation (related to net calorific value NCV / gross calorific value GCV)	%	96.5/87.0	96.4/86.9	96.0/86.5	96.5/87.0
• Boiler efficiency at 30 % partial load operation (EN 303) (related to net calorific value NCV / gross calorific value GCV)	%	97.4/87.7	97.4/87.7	97.3/87.7	97.4/87.7
• Standard efficiency (DIN 4702-8, 75/60 °C) (related to net calorific value NCV / gross calorific value GCV)	%	97.4/87.7	97.4/87.8	97.1/87.5	97.5/87.9
• Standing losses qB at 70 °C	Watt	850	1000	1200	1350
• Flue gas temperature at nominal output at 80/60 °C	°C	94	101	102	99
• Maximum chimney draught	Pa	20	20	20	20
• Flue gas resistance at nominal output 10.5 % CO ₂ natural gas 500 m over sea level (tolerance ± 20 %)	mbar	4.9	4.8	4.7	5.7
• Flue gas mass flow at nominal output 10.5 % CO ₂ natural gas	kg/h	1133	1623	2271	2923
• Flow resistance boiler ³⁾	z-value	0.012	0.012	0.003	0.003
• Water flow resistance at 20 K	mbar	10.8	22.0	10.8	17.9
• Water flow volume at 20 K	m ³ /h	30.0	42.9	60.0	77.1
• Boiler water content	litres	670	1130	1580	2020
• Insulation thickness boiler body	mm	80	80	80	80
• Weight (incl. cladding)	kg	1390	2100	2794	3500
• Weight (without cladding)	kg	1250	1960	2654	3200
• Heating surface	m ²	36.52	44.23	68.49	89.51
• Combustion chamber dimensions Ø inside x length	mm	584/1835	684/1985	830/2180	830/2301
• Combustion chamber volume	m ³	0.492	0.729	1.179	1.244
Dimensions		see table of dimensions			

¹⁾ Limited by the boiler controller T2.2 to 90 °C resp. U3.2 and T0.2 to 105 °C.

²⁾ Maximum safety temperature for boiler controller T2.2: 110 °C resp. U3.2 and T0.2: 120 °C.

³⁾ Flow resistance boiler in mbar = flow rate (m³/h)² x z

CompactGas (2200-4200)

Type		(2200)	(2800)	(3500)	(4200)
• Nominal heat output at 80/60 °C	kW	2200	2800	3500	4200
• Nominal heat output min./max. at 80/60 °C	kW	660-2200	840-2800	1050-3500	1260-4200
• Max. firing output	kW	2280	2901	3626	4351
• Boiler operating temperature ¹⁾ max.	°C	105	105	105	105
• Boiler operating temperature min.	°C	75	75	75	75
• Boiler return temperature min.	°C	35	35	35	35
• Safety temperature limiter setting (water side) ²⁾	°C	120	120	120	120
• Operating/test pressure	bar	6/9	10/16	10/16	10/16
• Boiler efficiency at 80/60 °C in full-load operation (related to net calorific value NCV / gross calorific value GCV)	%	96.5/87.0	96.5/87.0	96/86.5	96/86.5
• Boiler efficiency at 30 % partial load operation (EN 303) (related to net calorific value NCV / gross calorific value GCV)	%	97.5/87.8	97.5/87.8	97/87.3	97/87.3
• Standard efficiency (DIN 4702-8, 75/60 °C) (related to net calorific value NCV / gross calorific value GCV)	%	97.5/87.9	97.5/87.9	97/87.4	97/87.4
• Standing losses qB at 70 °C	Watt	1550	1800	2180	2290
• Flue gas temperature at nominal output at 80/60 °C	°C	93	92	93	91
• Maximum chimney draught	Pa	20	20	20	20
• Flue gas resistance at nominal output 10.5 % CO ₂ natural gas 500 m over sea level (tolerance ± 20 %)	mbar	6.5	7.2	7.9	8.5
• Flue gas mass flow at nominal output 10.5 % CO ₂ natural gas	kg/h	3571	4546	5665	6798
• Flow resistance boiler ³⁾	z-value	0.003	0.002	0.002	0.002
• Water flow resistance at 20 K	mbar	27	29	45	65
• Water flow volume at 20 K	m ³ /h	94	120	150	180
• Boiler water content	litres	2534	2844	3553	3628
• Insulation thickness boiler body	mm	80	80	80	80
• Weight (incl. cladding)	kg	4455	5702	7980	8200
• Weight (without cladding)	kg	4105	5302	7580	7800
• Heating surface	m ²	117.26	142.34	178.33	217.21
• Combustion chamber dimensions Ø inside x length	mm	830/3076	922/3272	1050/2998	1050/3308
• Combustion chamber volume	m ³	1.663	2.222	2.596	2.880
Dimensions		see table of dimensions			

¹⁾ Limited by the boiler controller T2.2 to 90 °C resp. U3.2 and T0.2 to 105 °C.

²⁾ Maximum safety temperature for boiler controller T2.2: 110 °C resp. U3.2 and T0.2: 120 °C.

³⁾ Flow resistance boiler in mbar = flow rate (m³/h)² x z

Flue gas and output diagram

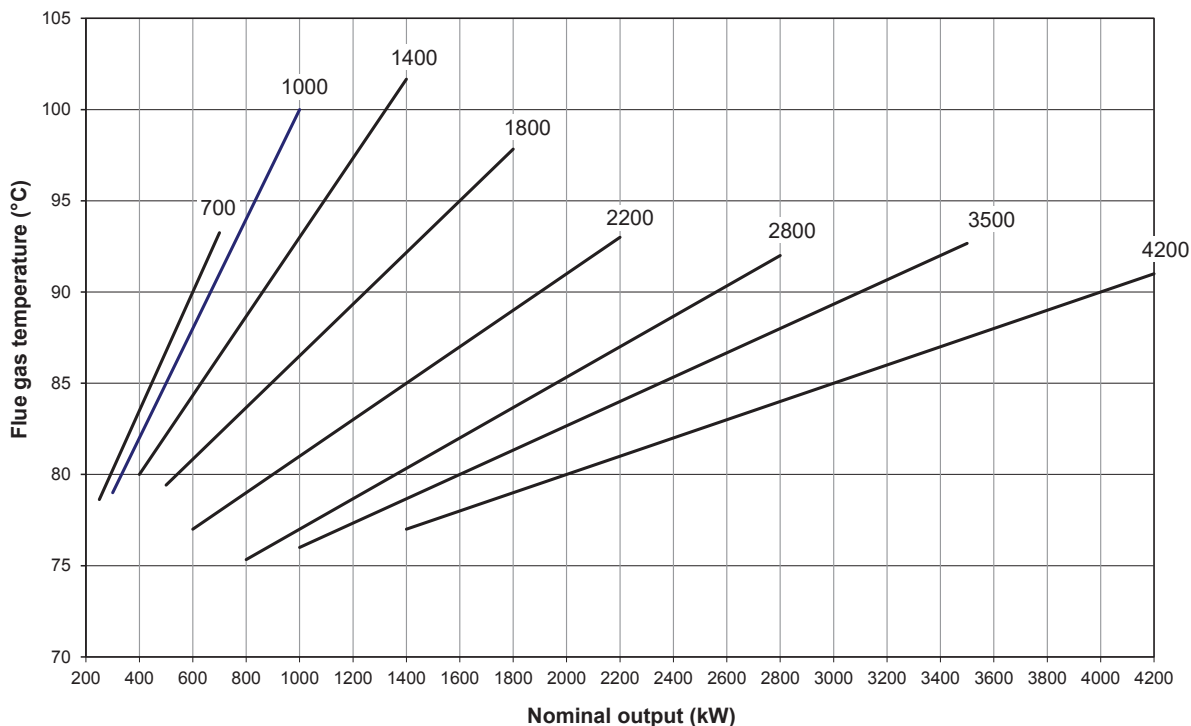

kW = Boiler output

°C = Flue gas temperature on clean surface, boiler flow temperature 80 °C, return temperature 60 °C (in accordance with DIN 4702).

- Operated with natural gas H, $\lambda = 1.15$ with max. burner output (CO₂ natural gas H = 10.5 %)
- A reduction of the boiler water temperature to -10 K causes a reduction of the flue gas temperature of approx. 6-8 K
- A modification of the lambda λ (CO₂ concentration) of ± 0.09 causes a modification of the flue gas temperature of approx. ± 8 K

Flue gas resistance

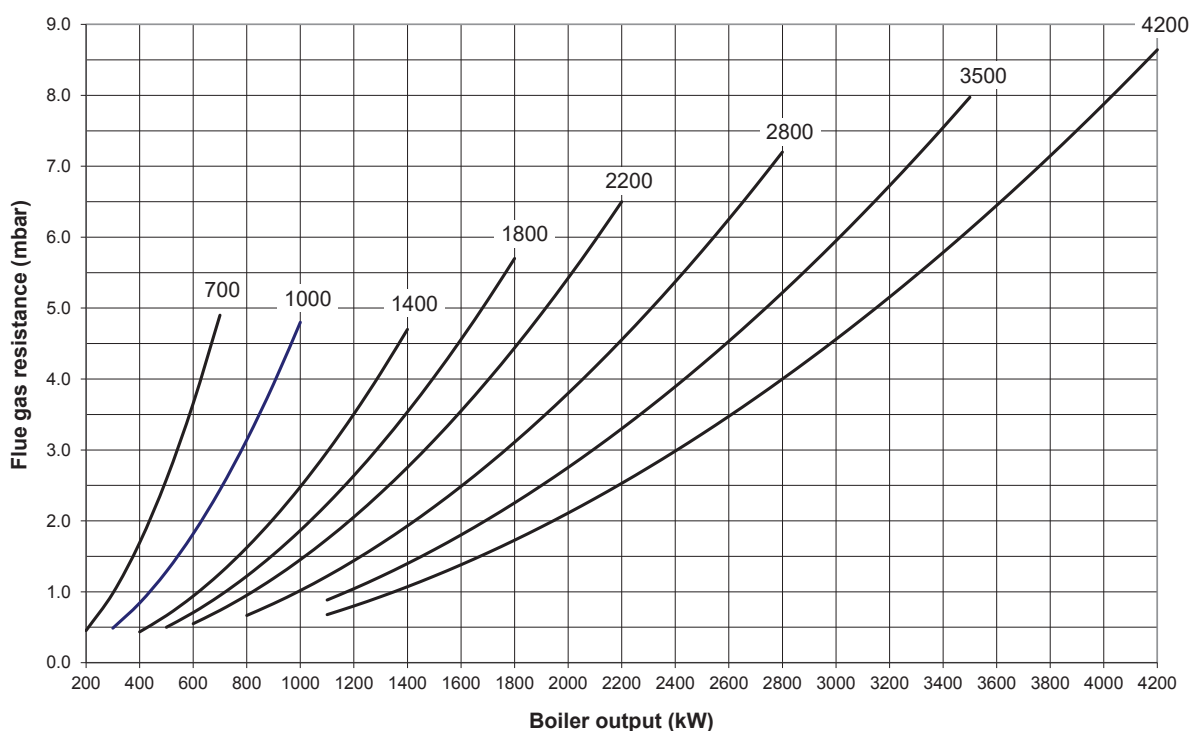

CompactGas (700-4200)
(Dimensions in mm)

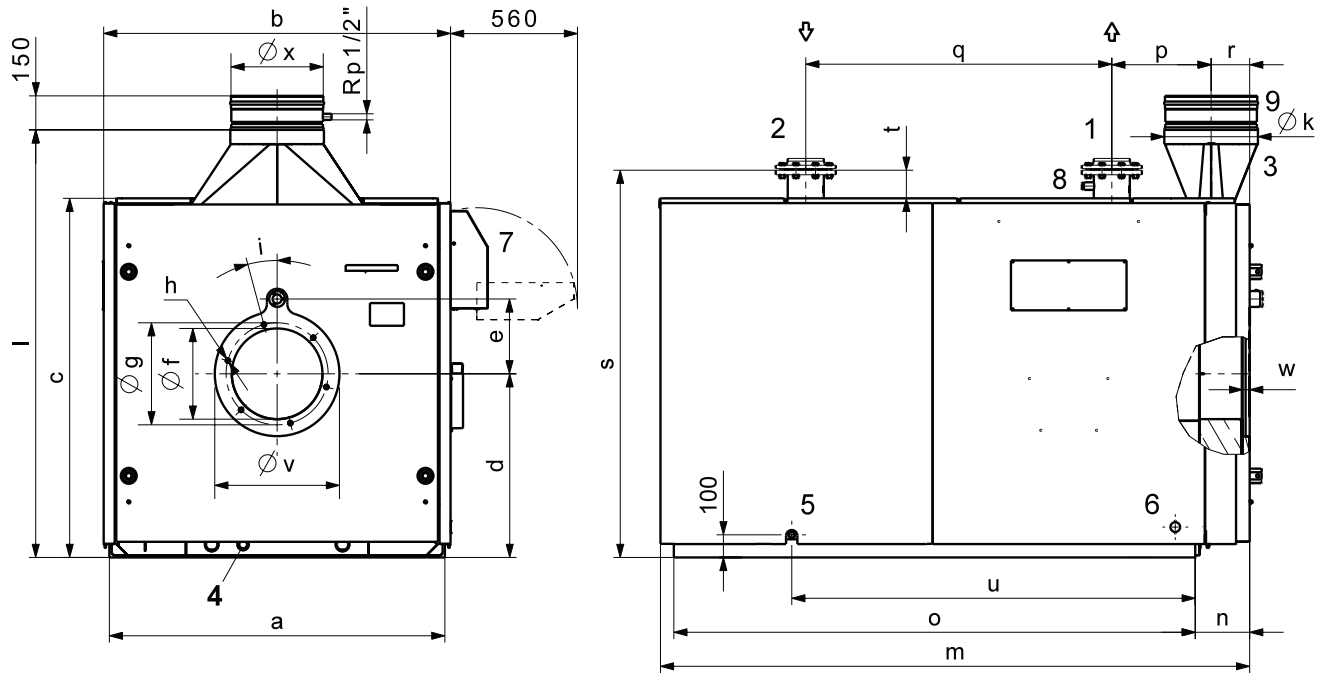

Type	a	b	c	d	e	f	g	h	i	k	l	m	n	o	p	q	r
(700)	1100	1150	1175	591	250	290	330	4xM12	15°/45°	303	1436	2229	240	1930	389	1110	170
(1000)	1280	1330	1384	710	310	350	400	6xM12	15°	353	1646	2430	240	2130	438	1210	170
(1400)	1480	1530	1584	810	330	400	450	6xM16	15°	403	1886	2600	240	2300	438	1350	170
(1800)	1580	1630	1684	860	360	400	450	6xM16	15°	453	2038	2790	257	2438	438	1350	187
(2200)	1580	1630	1684	860	360	400	450	6xM16	15°	453	2038	3529	257	3213	438	2125	187
(2800)	1680	1730	1784	910	360	400	450	6xM16	15°	503	2188	3745	257	3430	638	2100	187
(3500)	1850	1928	1995	1018	360	400	450	6xM16	15°	553	2398	3905	337	3510	668	2123	236
(4200)	1850	1928	1995	1018	360	400	450	6xM16	15°	603	2398	4205	337	3810	668	2423	236

Type	s	t	u	v	w	x
(700)	1271	96	1406	420	31	298/1
(1000)	1487	103	1564	500	31	348/1
(1400)	1708	124	1780	550	31	398/1
(1800)	1808	124	1884	600	48	448/1
(2200)	1808	124	2659	600	48	448/1
(2800)	1908	124	2799	600	48	498/1
(3500)	2121	126	3141	600 x 600	65	548/1
(4200)	2121	126	3441	600 x 600	65	598/1

- 1 Flow
 - (700) DN 125, PN 6
 - (1000) DN 125, PN 6
 - (1400) DN 150, PN 6
 - (1800) DN 150, PN 6
 - (2200) DN 150, PN 6
 - (2800) DN 200, PN 10
 - (3500) DN 200, PN 10
 - (4200) DN 200, PN 10
- 2 Return
 - (700) DN 125, PN 6
 - (1000) DN 125, PN 6
 - (1400) DN 150, PN 6
 - (1800) DN 150, PN 6
 - (2200) DN 150, PN 6
 - (2800) DN 200, PN 10
 - (3500) DN 200, PN 10
 - (4200) DN 200, PN 10
- 3 Flue gas outlet
- 4 Draining R 1"
- 5 Condensate drain D 31/25 mm (on both sides)
- 6 Electrical connection (on both sides)
- 7 Control panel (optionally left or right)
- 8 Sleeve Rp 3/4" with immersion pocket for boiler temperature sensor
- 9 Condensate trap

Tilting out of the boiler door

Boiler door opens to the right or left
(Dimensions in mm)

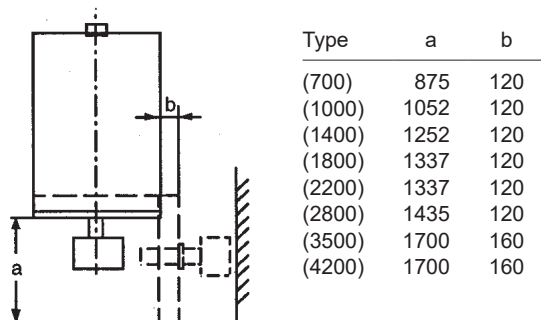

Type	a	b
(700)	875	120
(1000)	1052	120
(1400)	1252	120
(1800)	1337	120
(2200)	1337	120
(2800)	1435	120
(3500)	1700	160
(4200)	1700	160

Standards and guidelines

The official regulations for installation and operation must be observed. In particular, these are the country-specific standards (e.g. EN standard, DIN standards, ...) as well as the corresponding regional regulations.

The following standards and guidelines must be complied with:

- Hoval technical information and installation instructions
- hydraulic and technical control regulations of Hoval
- DVGW directives
- DIN EN 12828 Safety-relevant requirements
- DIN EN 12831 Heaters Rules for the calculation of the heat requirements of buildings
- VDI 2035 Protection against damage by corrosion and boiler scale formation in heating and service water installations
- EN 14868 Protection of metallic materials against corrosion
- VDE 0100 supplement 2

Water quality in heating systems Filling and replacement water, heating water

The following applies:

- VDI 2035
- In addition, the EN 14868 standard must be applied, **as well as the manufacturer-specific specifications**

Manufacturer-specific specifications

Filling and replacement water

The filling and replacement water can be both fully demineralised and also merely softened.

Heating water

- In the case of **full demineralisation of the filling and replacement water**, the electrical conductivity of the heating water must not exceed the value of 100 $\mu\text{S}/\text{cm}$.

- In the case of **softening the filling and replacement water**, the following conditions must be complied with:

The quality of the heating water must be checked and documented periodically:

- For an installed heat output above 100 kW up to and including 1000 kW, an annual check of the heating water is required.
- For an installed heat output above 1000 kW, an check of the heating water is required twice a year.

The following standard values for the heating water must be measured and adhered to:

- Electrical conductivity of the heating water for operation with water containing salts: $> 100 \mu\text{S}/\text{cm}$ to $\leq 1500 \mu\text{S}/\text{cm}$
- pH value of the heating water for systems without aluminium alloy as water-side material 8.2 to 10.0 (measurement 10 weeks after commissioning at the earliest)
- The sum of the chloride, nitrate and sulphate contents in the heating water must not exceed 50 mg/l in total.

Additional notices

- Hoval boilers and calorifiers are suitable for heating systems without significant oxygen intake. (System type I according to EN 14868).
- Plants with continual oxygen intake (e.g. underfloor heating without diffusion-proof plastic piping) or intermittent oxygen intake (e.g. requiring frequent topping-up) must be equipped with a system separation.
- If only the boiler is replaced in an existing plant, it is not recommended for the entire heating system to be refilled, provided that the heating water already contained in the system complies with the relevant directives or standards.
- Before filling new systems and, where necessary, existing heating systems containing heating water that does not comply with the directives or standards, the heating system must be professionally cleaned and flushed. The boiler must not be filled until the heating system has been flushed.

Frost protection agent

- see separate engineering sheet "Use of frost protection agent".

Combustion air supply

The combustion air supply must be warranted. The air opening must not be lockable. It is very important to ensure that the combustion air is free from halogen compounds. These are present, for example, in spray cans, varnishes, glues, solvents and cleansing agents.

- *Room air dependent operation:*

A minimum free cross-section of once 150 cm² or twice 75 cm² and an additional 2 cm² for each kW boiler capacity in excess of 50 kW is required for the air opening into the outside air.

Burner mounting

- For mounting of the burner an adapter flange may be required depending on the size of the burner flange. The adaptor flange including screws must be delivered by the burner company.
- Length and diameter of the burner pipe should be possible to swivel the boiler door incl. burner by 90°.
- So that the boiler door can be swung out around 90° to the left or right, the connections must be flexible and lead in a sufficient large loop to the burner.
- The space between burner pipe and hinged flange must be isolated. A line must be routed from the burner to the sight glass to carry cooling air, in order to cool the boiler sight glass and keep it clean. (Delivery by the burner company)

Electrical connection of the burner

- Control voltage 1 x 230 V
- Burner motor 1 x 230 V / 3 x 400 V.
- The burner must be connected to the burner connection plug of the boiler.
- For safety reasons the electrical cable of the burner must be that short that the plug must be removed when swivelling boiler door.

Sound absorbing

Sound absorption is possible through the following steps:

- Heating room walls, ceiling and floor should be very solidly built, a sound absorber should be mounted into the air inlet. Pipe holders and support should be protected by means of anti-vibration sleeves.
- Install sound attenuation cowl for burner.
- If living rooms are located above or under the boiler room, vibration absorbers have to be mounted to the boiler base. Pipes and flue gas tube must be connected flexibly with compensators.
- Connect circulating pumps to the piping network using expansion joints.
- For damping of flame noise it is possible to install a silencer into the flue gas tube (Space should be foreseen for later installation).

Measures for sound reduction

Make sure right from the planning phase that bedrooms are not situated in the immediate vicinity of the sound source (heating room, chimney).

A reduction of the radiated burner air sound level in the heating room (reduction of the burner noises) of up to approx. 12 dB can be achieved encapsulating the burner (sound attenuation cowl).

A significant part of the noise development in the combustion chamber and in the secondary heating surfaces is radiated as airborne noise via the flue gas line.

In addition, depending on dimensioning of the chimney and intersection, resonance effects caused by the vibration of the combustion noises (amplification) can occur.

These noises can be reduced on the one hand by measures on the burner side, such as modification of the flame geometry, the atomisation characteristic or the fuel throughput.

On the other hand, flue gas silencers achieve an important noise reduction.

These silencers must usually be adapted to low frequencies of 60-250 Hz.

Flue gas silencers work based on the principle of sound absorption.

The kinetic energy of the flue gases is consumed due to friction, which means a draughting requirement increase in the flue gas line is necessary. This must be taken into account when dimensioning the burner.

The connection piece from the boiler to the flue gas silencer must be gas-tight as the draught and pressure zero points lie behind the flue gas silencer.

The space required of approx. 1 m for retrofitting of a flue gas silencer should be provided during planning.

Note also that secondary air devices are installed only behind a flue gas silencer.

Installation instructions

Please observe the installation instructions supplied with every boiler.

Chimney/flue gas system

Flue gas tube

- The flue gas tube between boiler and chimney must be connected with an angle of 30-45° to the chimney.

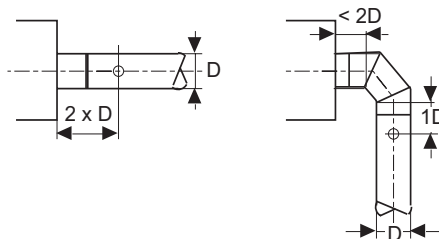

- The flue gas tube must be designed that no condensate can get into the boiler. A condensate trap must imperatively be mounted on the flue gas outlet of the boiler.
- A closeable flue gas measuring socket with an inner diameter of 10-21 mm must be foreseen.

Chimney system

- The flue gas system must be humidity-insensitive and acid proof and admitted up to 160 °C.
- For existing chimney installation the restoration must be carried out according to the instructions of the chimney constructor.
- Calculation of the profile of the chimney according to EN 13384-1 and 2.
- It is recommended to use a secondary air valve for chimney draft limiting. The air valve must be mounted after the flue gas sound absorber (if fitted).

Looking for the appropriate hydraulic schematic?
Please contact your local Hoval partner.