

# Condensing **NAVIENT**

Navigating Energy and Environment

## Installation Manual

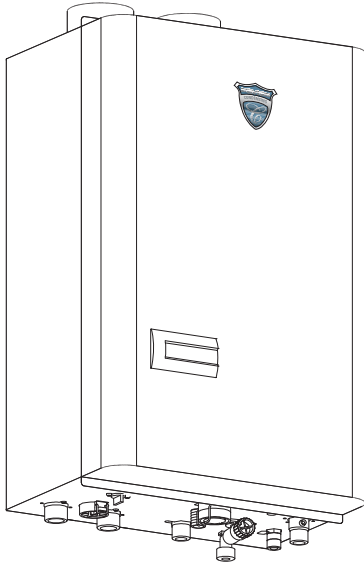

For potable water heating and space heating



MODEL

**CH-180**

**CH-210**

**CH-240**

Keep this manual near the Navien Combination Water Heater for future reference whenever maintenance or service is required.

### **⚠ WARNING**

**If the information in this manual is not followed exactly, a fire or explosion may result causing property damage, personal injury or loss of life.**

- Do not store or use gasoline or other flammable vapors and liquids in the vicinity of this or other appliance.
- **WHAT TO DO IF YOU SMELL GAS**
  - Do not try to light any appliance.
  - Do not touch any electrical switch: do not use any phone in your building.
  - Immediately call your gas supplier from a neighbor's phone. Follow the gas supplier's instructions.
  - If you cannot reach your gas supplier, call the fire department.
- Installation and service must be performed by a qualified installer, service agency or the gas supplier.

### **⚠ CAUTION**

**This product warranty is valid only used in the America and Canada but automatically be voided for other countries. (for America and Canada unit standard only)**





**Please return the "Installation Manual" to the customer after installing.**

# Installation Manual - Contents

<b>Accessories</b>	Included with the Combination Water Heater / Heating Boiler .....	3
	Optional Accessories .....	4
<b>Specifications</b>	.....	5
<b>Components &amp; Dimensions</b>	Key Components .....	6
	Dimensions .....	7
<b>Warnings</b>	Installation Warning .....	8
<b>Rating Plate</b>	Getting Started .....	10
	Check Rating Plate .....	11
<b>Location Selection</b>	Locating the Combination Water Heater / Heating Boiler .....	12
	Mounting the Unit to the Wall .....	13
<b>Plumbing</b>	Plumbing and Water Connection Guideline .....	14
	Plumbing Guideline .....	17
	.....	26
<b>Pressure Relief Valve</b>	Disposal of Condensate .....	27
<b>Condensate Disposal</b>	Condensate Drain & Cleaning .....	28
<b>Gas Piping</b>	Gas Piping Guideline .....	29
	Gas Supply Pressure .....	30
	Gas Piping Sizing Chart .....	31
<b>Gas Pressure Testing</b>	Measuring Inlet Gas Pressure .....	32
<b>Venting</b>	Warning .....	34
	Venting Guideline .....	35
	Contaminated Make-up Air Will Damage the Unit .....	36
	Exhaust Pipe Materials .....	36
	Venting Clearances .....	37
	Allowable Vent Lengths .....	38
	Vent Configuration Options .....	40
	Concentric Vent Termination .....	42
	Outdoor Installation .....	43
	.....	45
<b>Pressure Reducing Valve</b>	Outdoor Temp. Sensor Installation .....	47
<b>Outdoor Temp. Sensor</b>	Outdoor Temp. Sensor Installation Guideline .....	47
	K-Factor .....	48
	.....	49
<b>Electrical Connection</b>	.....	50
<b>Remote Controller</b>	.....	51
<b>Installation</b>	.....	51
<b>PCB Board Setting</b>	.....	52
<b>Cascade Connection and</b>	.....	52
<b>Set-up Procedure</b>	.....	57
<b>DIP Switch Setting</b>	.....	60
<b>Installation Checklist</b>	.....	64
<b>Maintenance</b>	.....	65
<b>Factory Setting of</b>	.....	66
<b>Dip Switch</b>	.....	66
<b>Completing the Install</b>	.....	67
<b>Wiring Diagram</b>	.....	68
<b>Ladder Diagram</b>	.....	70
<b>Wiring Information</b>	.....	70
<b>Components Diagram &amp;</b>	.....	79
<b>Parts List</b>	.....	79
<b>Service</b>	.....	79

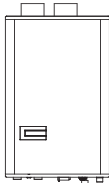
# Accessories:

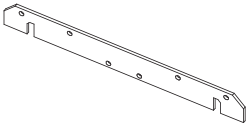
## 1 Included with the Combination Water Heater / Heating Boiler:

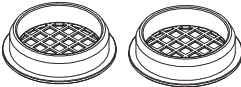
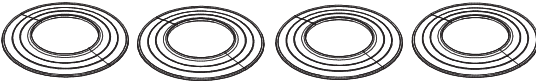
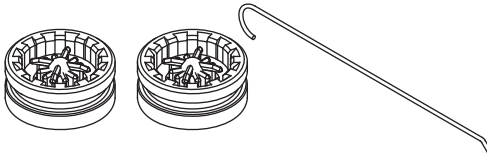

Item	Description	Qty
Navien Condensing Combination Water Heater / Heating Boiler		1
Remote Controller		1
Owner's and Installation Manual		1
Wall Mounting Bracket		1
Condensate Drain Hose		1
Tapping Screws & Anchors		4
Vent terminators		2
Wall Flanges		4
Pressure Reducing Valve Kit		2+1



Check that you have received all of the above parts before installing the Combination Water Heater / Heating Boiler.

## Optional Accessories:

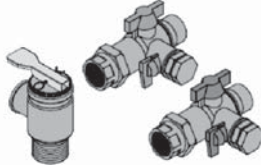
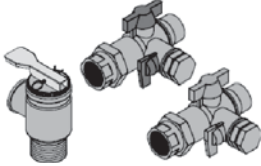
### 2 Optional Accessories:

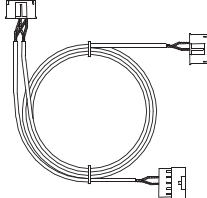
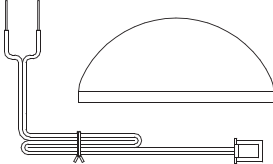
Item	Description
Navien Plumb Easy Valve Set (Pressure Relief Valve) – Heating (1")	
Navien Plumb Easy Valve Set (Pressure Relief Valve) – Domestic Water (3/4")	
Navien Condensate Neutralizer	
Navien Ready-Link Communication Cable	
Outdoor Temperature Sensor with Cable	



Contact your Navien combination Water Heater / Heating Boiler supplier for optional accessories.



# Specifications:

Please review these specifications before installation to confirm proper unit selection: As Navien is dedicated to continuous product improvement, Navien reserves the right to change specifications as well as re-design and / or discontinue any model or feature without prior notice and without incurring obligations.

Item		CH-180	CH-210	CH-240
Heat Capacity (Input)	Natural Gas	Min: 17,000 Btuh Max: 150,000 Btuh	Min: 20,000 Btuh Max: 175,000 Btuh	Min: 20,000 Btuh Max: 199,000 Btuh
Flow Rate (DHW)	35°F Rise	8.3 GPM	10.0 GPM	11.0 GPM
	45°F Rise	6.5 GPM	7.7 GPM	8.6 GPM
	77°F Rise	3.8 GPM	4.6 GPM	5.1 GPM
Dimensions		W17" x H28" x D12"	W17" x H28" x D12"	W17" x H28" x D12"
Weight		74 lbs	84 lbs	84 lbs
Efficiency AFUE	NG	91%	91%	91%
	Propane	90.5%	90.2%	90.8%
Installation Type		Indoor/Outdoor Wall-Hung		
Venting Type		Forced Draft Direct Vent		
Ignition		Electronic Ignition		
Water Pressure (min-max)		15 – 150 PSI		
Gas Supply Pressure (from source; min-max)		NG: 3.75" WC ~ 10.5" WC		LP : 10.5" WC ~ 13.5" WC
180 Manifold Gas Pressure (min-max)		NG: 0.4" WC ~ 3.7" WC		LP : 0.8" WC ~ 7.3" WC
210 Manifold Gas Pressure (min-max)		NG: 0.4" WC ~ 3.0" WC		LP : 0.8" WC ~ 5.3" WC
240 Manifold Gas Pressure (min-max)		NG: 0.6" WC ~ 4.0" WC		LP : 1.0" WC ~ 7.0" WC
Minimum Flow Rate		0.5 GPM		
Connection Sizes	S/Heating Supply/ S/Heating Return	1" NPT		
	DHW Cold Water Inlet/ DHW How Water Supply	3/4" NPT		
	Auto Feeder	1/2" NPT		
	Gas Inlet	3/4" NPT		
Power Supply	Main Supply	120VAC, 60Hz		
	Maximum Power Consumption	200W (max 2A)		
Materials	Casing	Cold Rolled Carbon Steel		
	Heat Exchangers	Primary Heat Exchanger: Stainless Steel Secondary Heat Exchanger: Stainless Steel Domestic water Heat Exchanger: Stainless Steel		
Venting	Exhaust (ø3")	ø3" PVC, ø3" Special Gas Vent Type BH (Class II (PVC) and Class I (Stainless Steel))		
	Intake (ø3")	PVC, Flex Aluminum, Flex Stainless Steel, ABS,		
	Vent Clearances	0" to combustibles		
Safety Devices		Flame Rod, Thermal Fuse(Overheat Cut Off device) APS, GPS, Gas-Valve Operation Detector, Ignition Operation Detector, Water Temperature High Limit Switch, Exhaust Temperature High Limit Switch		
Accessories		Plumb Easy Valve Set, Venting Kit, Condensate Neutralizer		

# Key Components: CH

## NAVIEN Combination Water Heater / Heating Boiler

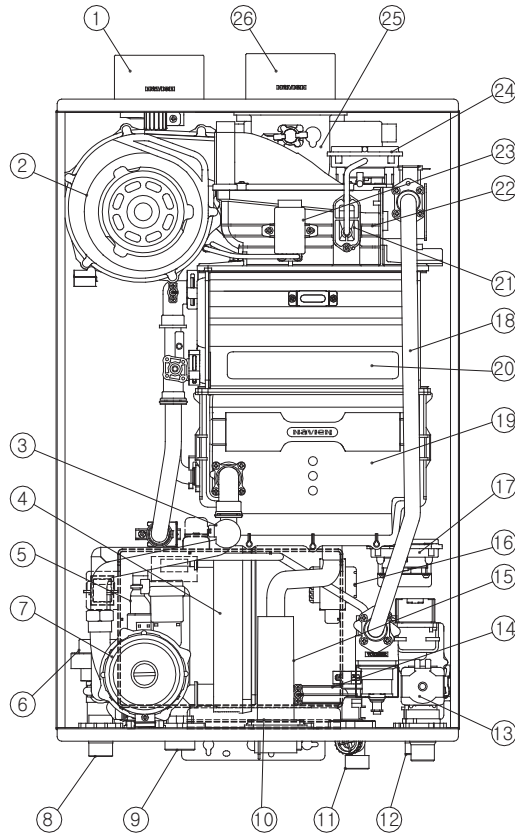

No	Description	Navien Part No.	No	Description	Navien Part No.
1	Intake Air Duct	BH2505400B	14	DHW Flow Sensor	AASS9EXFS002A
2	Fan Motor	NAFA9GSFB002	15	Syphon	BH2501442C
3	WPS	BH2507535A	16	Transformer	BH1205011C
4	DHW Heat Exchanger	PAS40KHE_003	17	Gas Pressure Sensor	NASS9EXGPS01
5	S/H Strainer	BH1301020C	18	Gas Pipe	BH2546021A
6	Motorized 3-Way Valve	AAVC9EX00009A	19	Secondary Heat Exchanger	-
7	Circulation Pump	NAPU9GLPCT10	20	Primary Heat Exchanger	-
8	S/H Supply Adaptor	BH2507551A	21	APS Venturi	BH2501413A
9	S/H Return Adaptor	BH2507551A	22	Burner	PABNCW48KDN_002
10	PCB Board	NACR1GS32301	23	Ignition Transformer	BH1201045A
11	DHW Cold Water Inlet Adapter	BH2507560C	24	Air Pressure Sensor	NASS9EX00009
12	Auto Feeder Valve	BH0904011A	25	Exhaust Duct	BH2544007D
13	Main Gas Valve	BH0901018A	26	Exhaust Pipe	BH2505401B

# Dimensions: CH Models

■ CH

	Description	Diameter
A	Exhaust Pipe	3"
B	Intake Air Duct	3"
C	Space Heating Supply Connection	1"
D	Space Heating Return Connection	1"
E	DHW Supply Connection	3/4"
F	DHW Cold Water Inlet Connection	3/4"
G	Auto Feeder Connection	1/2"
H	Gas Inlet Connection	3/4"

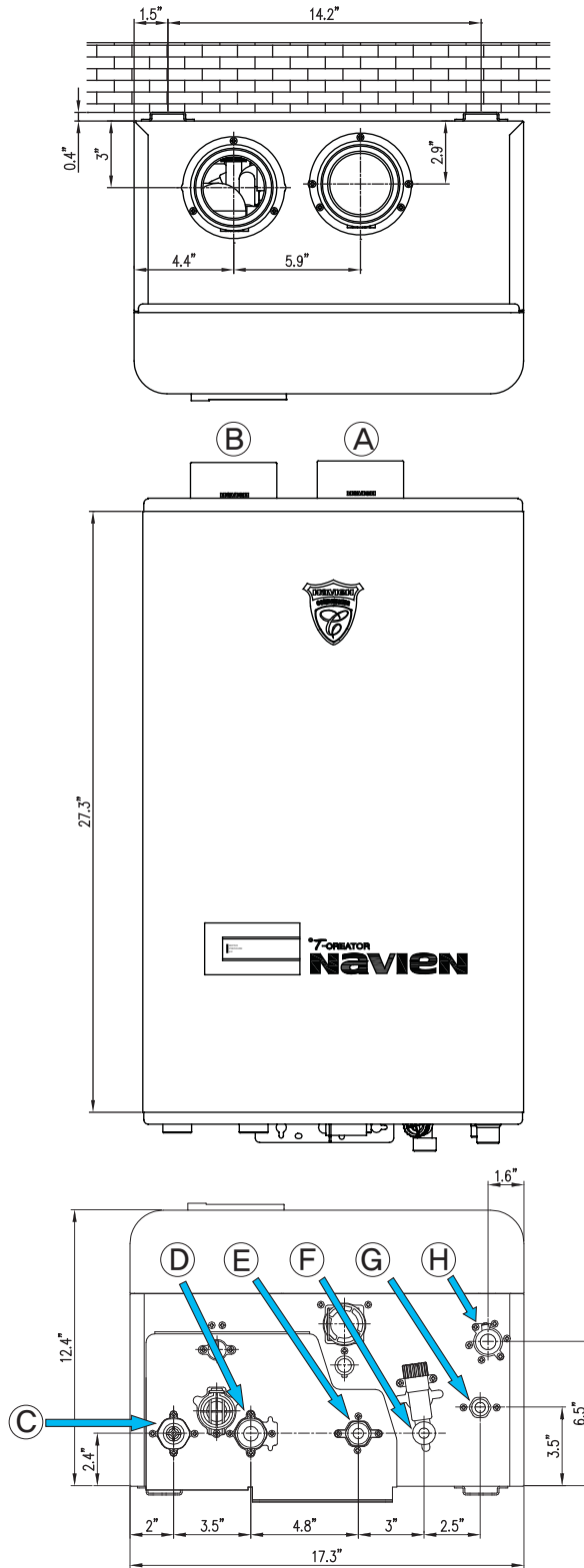

## Installation Warnings:



### WARNING

Read all safety warnings in the “User’s Operation Manual”. The additional safety issues outlined below must also be followed completely when installing this Navien Combination Water Heater / Heating Boiler.



### WARNING

Failure to remove or maintain the area free of combustible material, gasoline and other flammable liquids or vapors can result in severe personal, injury, death or substantial property damage.

1. All applicable local, state, national and provincial codes, ordinances, regulations and laws.
2. For installations in Massachusetts – code requires the boiler to be installed by a licensed plumbing or gas fitter.
3. The National Fuel Gas Code NFPA 54/ ANSI Z223.1
4. National Electric Code ANSI/NFPA 70.
5. For Installations in Canada – “Installation Code for Gas Burning Equipment” CGA/B 149.1 or B149.2 Canadian Electrical Code Part 1 CSA C22.1
6. Standard for Controls and safety devices for automatically fired boilers, ANSI/ASME CSD-1, when required.
7. The installation must conform to the requirements of the authority having jurisdiction or, in the absence of such requirements, to the National Fuel Gas Code, ANSI Z223.1/NFPA 54 and/or CAN/CSA B149.1, Natural Gas and Propane Installation Code.



### WARNING

Follow all local codes and/or the most recent edition of the National Fuel Gas Code (ANSI Z223.1/NFPA 54) in the USA or the Natural Gas and Propane Installation Code in Canada (CAN/CGA B149.1).

8. This unit is designed for indoor/outdoor installations. DO NOT operate this unit without the vent piping connected. Exhaust gases must be completely expelled out of the building.
9. DO NOT use this appliance if any part has been underwater. Immediately call a qualified service technician to inspect the appliance and replace any part of the control system and any gas control which has been underwater.
10. Be sure not to reverse the water and gas connections as this may damage the gas valves.
11. Water temperature over 125°F can cause severe burns instantly or death from scalding. If the proposed Water Heater / Heating Boiler outlet temperature is above 125°F, a thermostatically controlled mixing valve (or a temperature limiting valve) for reducing point of use water temperature is recommended to reduce the risk of scald injury. Contact a licensed plumber or the local plumbing authority for further information.
12. The appliance should be located in an area where leakage within the unit or at its connections will not result in damage to the surrounding area. Navien will not be responsible for any damage resulting from leaking if adequate drainage is not provided.
13. DO NOT use this combination Water Heater / Heating Boiler for any purpose other than water heating and space heating.
14. If the water quality is known to be highly acidic and/or extremely hard, water treatments (i.e water softeners) are recommended to maintain full warranty. Consult the local water authority.

# Installation Warnings:



## WARNING

15. Protect against snow accumulation around the vent terminations. Ensure the exhaust pipe and the intake air pipe remain clear from obstructions at all times.
16. DO NOT overtighten fittings as pipe and/or fitting damage may occur causing leakage.
17. DO NOT install the combination Water Heater / Heating Boiler where subject to vibrations.
18. The vent for this appliance shall not terminate over public walkways, or near soffit vents, crawl space vents and other areas where condensate or vapor could create a nuisance, hazard or cause property damage. Or where condensate and vapor could cause damage to or could be detrimental to the operation of regulators, relief valves, or other equipment.
19. For other than a direct vent appliance, the appliance must be located as close as possible to a chimney or gas vent.
20. Should overheating occur or the gas supply fails to shut off, turn off the manual gas control valve to the appliance. Contact a Service Technician immediately.
21. The gas connections and water connections must be leak tested before placing into operation.
22. After placing into operation the ignition safety device must be tested.
23. Visually inspect the venting system for proper size and horizontal pitch and determine there is not blockage or restriction, leakage, corrosion and other deficiencies which could cause an unsafe condition.
24. Insofar as is practical, close all building doors and windows and all doors between the space in which the appliances remaining connected to the common venting system are located and other space of the building. Turn on cloths dryers and any appliance not connected to the common venting system. Turn on any exhaust fans, such as range hoods and bathroom exhausts, so they will operate at maximum speed. Do not operate a summer exhaust fan. Close fireplace dampers.
25. Place in operation the appliance being inspected. Follow the lighting instructions. Adjust thermostat so appliance will operate continuously.
26. After it has been determined that each appliance remaining connected to the common venting system properly vents when tested as outlined above, return doors, windows, exhaust fans, fireplace dampers and any other gas-burning appliance to their pervious condition of use.
27. Any improper operation of the common venting system should be corrected so the installation conforms with the National Fuel Gas Code, ANSI Z223.1/NFPA 54 and/or CAN/CSA B149.1, Natural Gas and Propane Installation Code. When resizing any portion of the common venting system, the common venting system should be resized to approach the minimum size as determined using the appropriate tables in Appendix F in the National Fuel Gas Code, ANSI Z223.1/NFPA 54 and/or CAN/CSA B149.1, Natural Gas and Propane Installation Codes.
28. The instructions for the installation of the venting system shall specify that the horizontal portions of the venting system shall be supported to prevent sagging; the methods of and intervals for support shall be specified. These instructions shall also specify that the venting system:
  - For Category I, II and IV boilers, have horizontal runs slopping upwards not less than 1/4 inch per foot (21 mm/m) from the boiler to the vent terminal;
  - For Category II and IV boilers, be installed so as to prevent accumulation of condensate; and
  - For Category II and IV boilers, where necessary, have means provided for drainage of condensate.
29. "Caution: Label all wires prior to disconnection when servicing controls. Wiring errors can cause improper and dangerous operation."
30. "Verify proper operation after operation servicing."

# Getting Started:



## CHECK THE RATING PLATE

Navien units come from the factory configured for use with either Liquid Propane (LP) or Natural Gas (NG). **Before starting the installation**, check the rating plate (side of unit) of the combination Water Heater / Heating Boiler to ensure the unit matches gas type, gas pressure, water pressure and electrical supply. **If the unit does not match the following requirements, Do Not Install;**



### WARNING

Be sure the gas type and electricity voltage match the Rating Plate.

- ❑ Use only the gas type indicated on the rating plate of the Navien Combination Water Heater / Heating Boiler. Using a different gas type will cause abnormal combustion and Water Heater / Heating Boiler malfunction.
  
- ❑ Be sure to use 120VAC 60Hz minimum 2A current. Using abnormally high or low AC voltage may cause abnormal operation, and may reduce the life expectancy of this product.

### Check the gas!

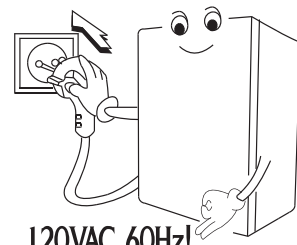
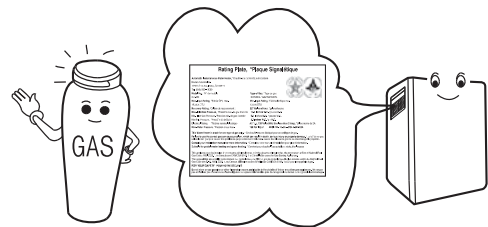

**120VAC 60Hz!**

If not certain, please contact Navien immediately.



### WARNING

Conversion of this unit from natural gas to propane or vice versa cannot be done in the field. Please re-confirm gas type on the rating plate (side of unit) before installing. **DO NOT** attempt any field conversion; this will result in dangerous operating conditions and will void all warranty.

**Navien America Inc. is not liable for any property damage and/or personal injury resulting from unauthorized conversions.**

# Check Rating Plate:

## Sample Rating Plate

**Rating Plate, \*Plaque Signalétique**

**Automatic Instantaneous Combination Water Heater / Heating Boiler**  
 \*Chauffe-eau automatique instantané  
 Navien America Inc.  
**20 Goodyear Irvine CA 92618 USA**  
**Tel: (949) 420 – 0420**

**Model No. , \*N° de modèle**  
 CH-180

**Max. Input Rating, \*Entrée GFL max.**  
 150,000 BTU

**Recovery Rating, \*Calibre de recouvrement :**

**Max. Inlet Gas Pressure, \*Pression max. de gaz d'entrée**  
 Min. Inlet Gas Pressure, \*Pression min. de gaz d'entrée  
 Manifold Pressure, \*Pression d'admission

**Electrical Rating, \*Régime nominal électrique**  
**Max. Water Pressure, \*Pression de eau max.**



SAMPLE

**Type of Gas**  
 N.G

**Min. Input Rating, \*Débit calorifique max.**  
 17,000 BTU

**227 Gallons/Hour, \*gallons/heures**  
**10.5 Inches W.C. \*pouces W.C.**  
**3.75 Inches W.C. , \*pouces W.C.**  
**3.7 Inches W.C. \*po W.C.**

**AC \*c.a. 120 Volts 60Hz Use less than 2 Amp, \*Utilisé moins de 2A**  
**150 Psi \*lb/po2 ANSI Z21. 10. 3b – CSA 4.3B-2004, Z21.13 – CSA 4.9**

**DO NOT install the Navien Combination Water Heater / Heating Boiler in areas with excessive high humidity:**

- ▶ DO NOT install the unit in a location where there is excessive high humidity such as a bathroom, damp crawl space and other areas such as this. This may cause the unit to malfunction.
- ▶ To avoid possible electrical shock, DO NOT touch the internal components of the combination Water Heater / Heating Boiler or the power plug with wet hands;
- ▶ DO NOT splash excessive water on the combination Water Heater / Heating Boiler or remote controller when cleaning; they are water resistant, not water proof;



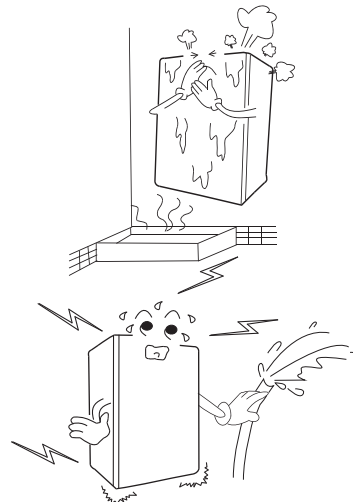

# Locating the Combination Water Heater / Heating Boiler:



## WARNING

Considering the Location “in accordance to ANSI Z223.1/ NFPA 54 and/or CAN/CSA B149.1 Gas Installation Code”

Location selection may not necessarily affect the operation of the Navien Combination Water Heater / Heating Boiler but it will affect the customer's experience and level of satisfaction with the product. Understanding that each building is different, the contractor will have to select the best location based on a combination of the following factors:

1. Locate the Navien Combination Water Heater / Heating Boiler close to a drain where condensed water and possible water leakage will not do damage to surrounding areas. A significant amount of condensed water will be produced each time the combination Water Heater / Heating Boiler is used. In addition, as with any water heating appliance, the potential for leakage at some time in the life of the product does exist. If there is no drain, Navien will not be responsible for any water damage that may occur.
2. Locate where the city water supply comes into the building.
3. Locate where the gas supply comes into the building.
4. Locate the main fixtures in the home (bathrooms, kitchen, laundry, etc.). Select a location that minimizes the water piping distance between the major fixtures.
5. Consider venting options: Select a location that minimizes the amount of venting required. Consider, 4 feet venting restrictions from windows, doors, air intakes, gas meters, neighbor's house, etc.
  - Maintain proper clearances from any openings in the building (see chart in venting section).
  - Navien combination Water Heater / Heating Boiler requires a minimum clearance of 12 inches above the exterior grade.
  - Do not install the Water Heater / Heating Boiler where moisture from the exhaust may cause discoloration or damage to walls.
  - Install the exhaust vent so that there are no obstacles around the termination and so that exhaust cannot accumulate.
  - Do not enclose the termination.
  - Do not install the combination Water Heater / Heating Boiler near vents for heating or cooling. A minimum distance of 4 feet (1.2m) should be maintained.
6. It is not recommended to install the combination Water Heater / Heating Boiler in bathrooms, bedrooms, any occupied rooms normally kept closed, or in indoor areas without proper venting.
  - This water heater/boiler must not be installed over carpeting.
7. Select a location that ensures the Water Heater / Heating Boiler will have sufficient and clean, combustion air; avoid installation where dust or debris will accumulate; avoid installation where chemical agents (e.g., hair spray, spray detergent, chlorine, chemicals) are used.



## Locating the Combination Water Heater / Heating Boiler:

- If installing into a very tight space or corner, please ensure there is sufficient service and maintenance access to all gas and water piping to ensure that regular maintenance (such as cleaning the water filter, the air filter and the condensate trap) will not become problematic.

Allow sufficient clearance:

	Indoor Install	Outdoor Install
Top of Water Heater / Heating Boiler	Min. 9 inches	Min. 36 inches
Back of Water Heater / Heating Boiler	Min. 0.5 inches	Min. 0.5 inches
Front of Water Heater / Heating Boiler	Min 4 inches	Min. 24 inches
Sides of Water Heater / Heating Boiler	Min. 3 inches	Min. 3 inches
Bottom of Water Heater / Heating Boiler	Min. 12 inches	Min. 12 inches

- DO NOT install in an area that contains or stores gasoline or other flammables.
- Ensure that combustibles are clear of the immediate area. Ensure hanging laundry or other such items will not impede the air movement into or out of the Water Heater / Heating Boiler or its venting.
- For commercial applications, avoid greasy fumes or a large amount of steam; take measures to prevent the fumes and steam from entering in the equipment.
- The boiler piping system of a hot water boiler connected to heating coils located in air handling units where they may be exposed to refrigerated air circulation must be equipped with flow control valves or other automatic means to prevent gravity circulation of the boiler water during the cooling cycle.

## Mounting the Unit to the Wall:

- All Navien units come with an upper mounting bracket pre-drilled at 16" on center for easy installation on standard stud walls. Affix the bracket to the wall securely, ensuring that it is level and that it can support the weight of the combination Water Heater / Heating Boiler. If the strength of the wall is not sufficient, reinforce the area to prevent any unsafe situations.
- If the framing is not standard, reinforcement of the wall is required or if installing on an uneven surface, fasten 3/4" plywood to the stud wall and then attach the mounting brackets to the plywood.
- When using the supplied mounting bracket, it creates a 5/8" clearance from the back of the unit.
- The upper bracket is installed on the wall and the combination Water Heater / Heating Boiler is then hung on the bracket. On the back of the combination Water Heater / Heating Boiler at each of the top corners, there is a hanger bracket on the back of the combination Water Heater / Heating Boiler that interlocks with a tabs on the wall mounting bracket.

## Plumbing: Plumbing and Water Connection Guidelines

- The piping materials used should meet local codes and industry standards.
- Piping must be cleaned and flushed-out before installation.
- Do not apply torch heat within 12" of the bottom connections of the unit.
- Perform all solder connections at a safe distance from the (brass) male connectors below the unit. Allow fittings to cool, before attaching to unit. Use only approved coupling unions with O-rings to attach field piping to unit.
- The 'heating' pipe should be 1" or bigger diameter copper or PEX. Never use aluminum, PVC or galvanized steel piping.
- The pipe size used for supply heating water should be the same size used for the return heating water.
- Use only copper piping with lead-free solder for the domestic water side.
- The size of the domestic hot water pipe should be 1" diameter.
- The length of piping should be as short as possible and the piping should have minimal number of bends and connections.
- Use only ball type isolating valves. Do not use gate valves.
- Never leave the heating pipes disconnected while operating the unit as a Water Heater / Heating Boiler. This will cause damage to the heat exchanger and void the manufacturers warranty.
- All piping should be insulated.
- After making the piping connections, check for gas or water leaks.
- If the water supply pressure is 142 psi or higher, install the water pressure regulator on the water supply piping.



### CAUTION

**Do Not open the Auto Feeder Connection cap, unless the pipe is connected to the Auto Feeder valve.**

# Plumbing:



## WARNING

Failure to properly pipe Water Heater / Heating Boiler may result in improper operation and damage to the Combination Water Heater / Heating Boiler or structure.



## CAUTION

This Combination Water Heater / Heating Boiler must only be used with the following water supply system conditions;

- With clean, potable water free of corrosive chemicals, sand, dirt, or other contaminants.
- With inlet water temperatures above 32°F(0°C), but not exceeding 140°F(60°C).
- Free of lime and scale deposits.

### Low Water Cut Off device

1. Navien Combination Water Heater / Heating Boiler is equipped with a factory installed pressure sensor type Low Water Cut Off device.
2. The Minimum operation system pressure allowable with this device is 7 psig.
3. Check local code if a Low Water Cut Off is required. If so, determine if this device meets the requirements of the local codes.
4. If a separate LWCO device is required by certain local jurisdictions or when the Navien Combination Water Heater / Heating Boiler is installed above the system piping, the following guidelines must be followed:
  - The LWCO device must be installed in a tee connection on the Water Heater / Heating Boiler /supply piping above the Water Heater / Heating Boiler.



## CAUTION

If the installation is to comply with ASME or Canadian requirements, an additional high temperature limitation device may be needed. Consult local code requirements to determine compliance.

### Backflow Preventer

- Use a backflow preventer valve in the make-up water supply to the unit as required by local codes.
- A hot water boiler installed above radiation level or as required by the Authority having jurisdiction, must be provided with a low water cutoff device either as a part of the boiler or at the time of boiler installation.

# Plumbing:

## Space Heating Freeze Protection

- ❑ Space heating system freeze protection products may be used in lieu of product referenced above. In general, freeze protection for new or existing systems must use specially formulated glycol, which contains inhibitors, preventing the glycol from attacking the metallic system components. Insure that system fluid contains proper glycol concentration and inhibitor level.
- ❑ The system should be tested at least once a year and as recommended by the manufacturer of the glycol solution. Allowance should be made for expansion of the glycol solution.



### CAUTION

**Use only inhibited propylene glycol solutions specifically formulated for hydronic systems. Do not use ethylene glycol, which is toxic and can attack gaskets and seals used in hydronic systems.**

## Expansion Tank

- ❑ The expansion tank must be located as shown in A~F basic application drawings.(page 20 ~ 25) (Refer to the expansion tank manufacturer's instructions for additional installation details.)
- ❑ Connect the expansion tank to an air separator only if the air separator is located on the suction side of the system circulator.
- ❑ Always locate and install the system fill connection at the same location as the expansion tank's connection to the system.
- ❑ If the expansion tank must be replaced, consult the expansion tank manufacturer's literature for proper sizing.

## Diaphragm Expansion Tank

- ❑ Always install an automatic air vent on the top of the air separator to remove residual air from the system.

## Closed-Type Expansion Tank

- ❑ It is recommended to pitch any horizontal piping upward toward the expansion tank 1 inch per 5 feet of piping.
- ❑ Use 3/4" piping for the expansion tank to allow air within the system to rise.



### CAUTION

**Do not install automatic air vents on a closed-type expansion tank system. Air must remain in the system and be returned to the expansion tank to provide an air cushion.**

# Plumbing: Guide Line



## CAUTION

This drawing can be a useful guideline when installing a unit. However, installation may vary depending on the location circumstances, local building codes or state regulation. Make sure to check the local building codes and state regulation before installation, and comply with it.

### Case I. With backflow preventer Installation

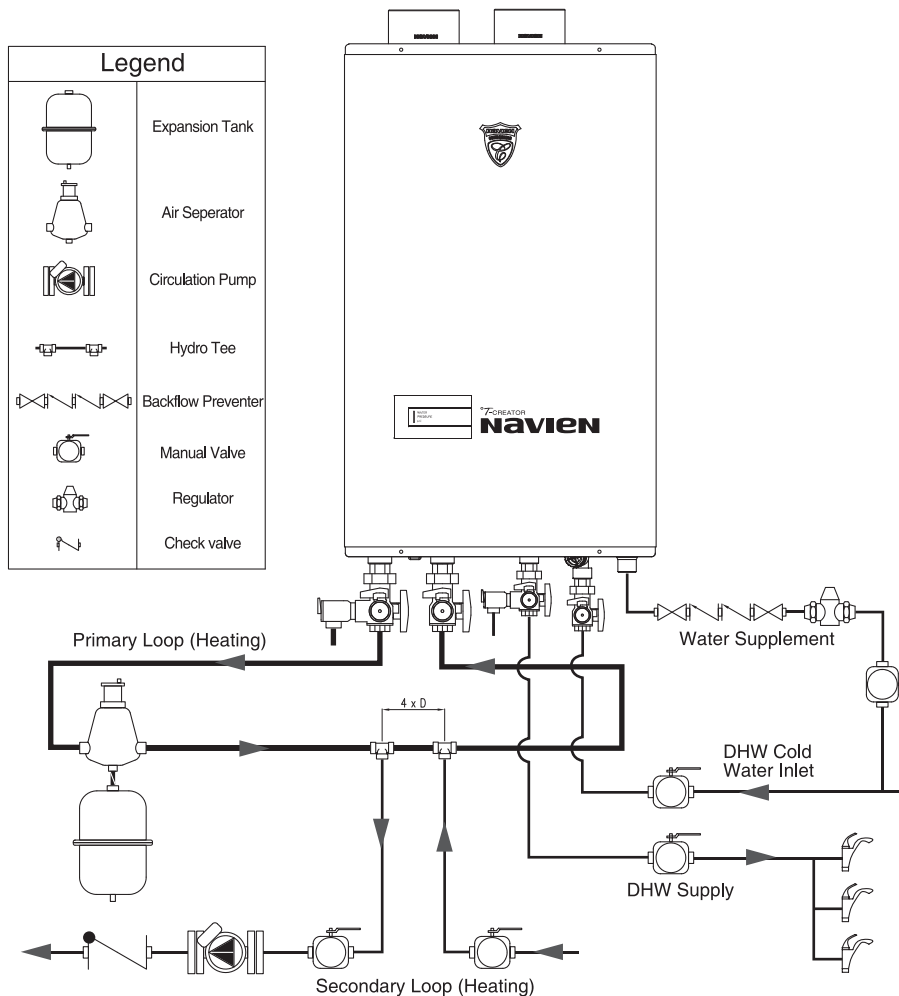

**NOTICE :** If using mixing valves on the domestic hot water outlet, choose one which prevents cold water pressure from overcoming hot water line pressure. The flow rate of hot water may vary when more than two faucets (appliances, fixtures, etc.) are being used simultaneously. If a combination Water Heater / Heating Boiler is installed in a closed water supply system, such as one having a backflow preventer in the cold water supply line, means shall be provided to control thermal expansion device. Contact the water supplier or local plumbing inspector on how to control this situation.

As shown above, Navien recommends installing the water supplement plumbing.

# Plumbing:

## Plumbing Guideline

### Case II. Non-backflow preventer Installation

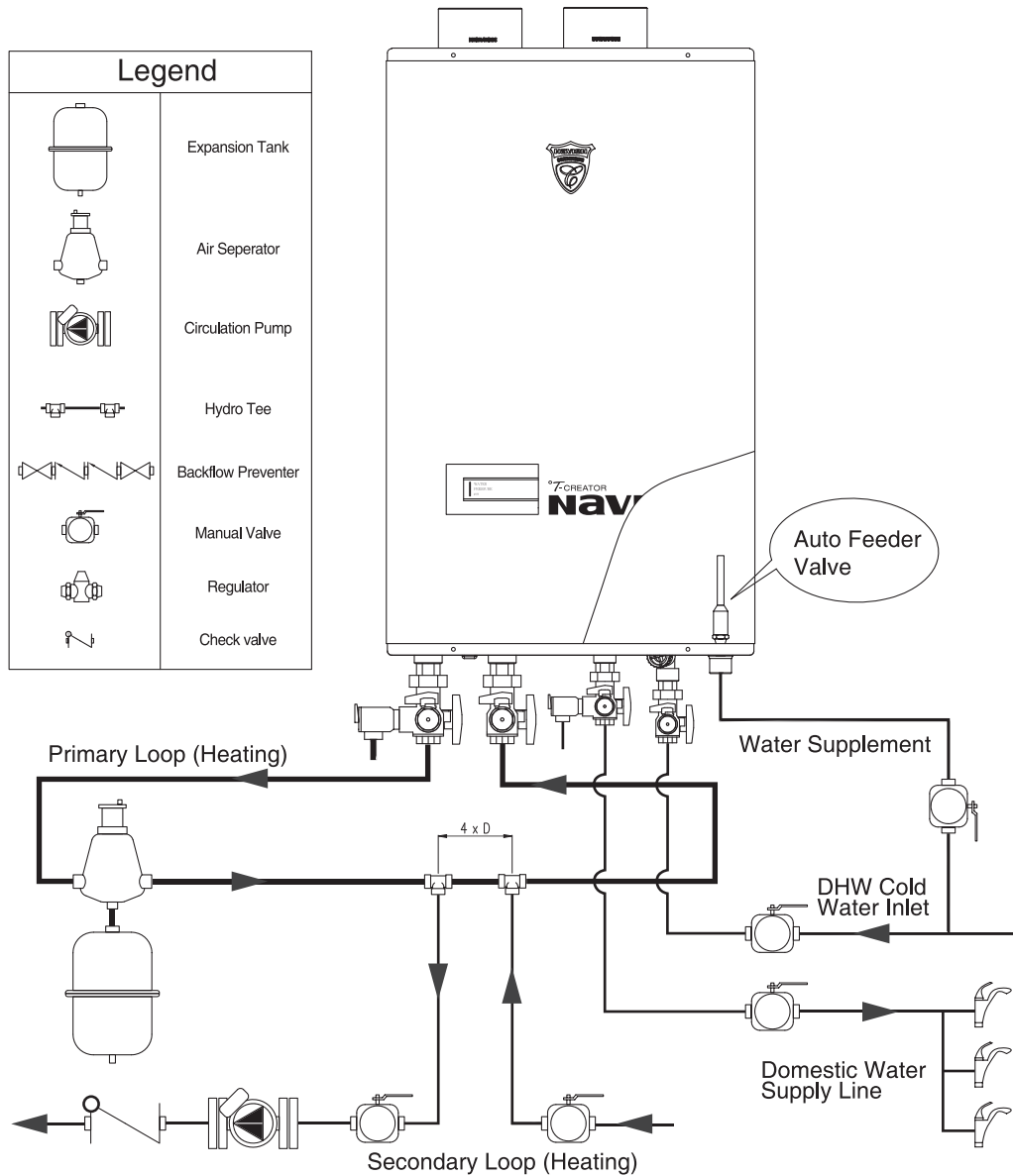

**NOTICE :** If using mixing valves on the domestic hot water outlet, choose one which prevents cold water pressure from overcoming hot water line pressure.  
Hot water Temperature may vary when more than two faucets (appliances, fixtures, etc.) are being used simultaneously.

# Plumbing:

## Case III. Non-Auto supplement backflow preventer Installation

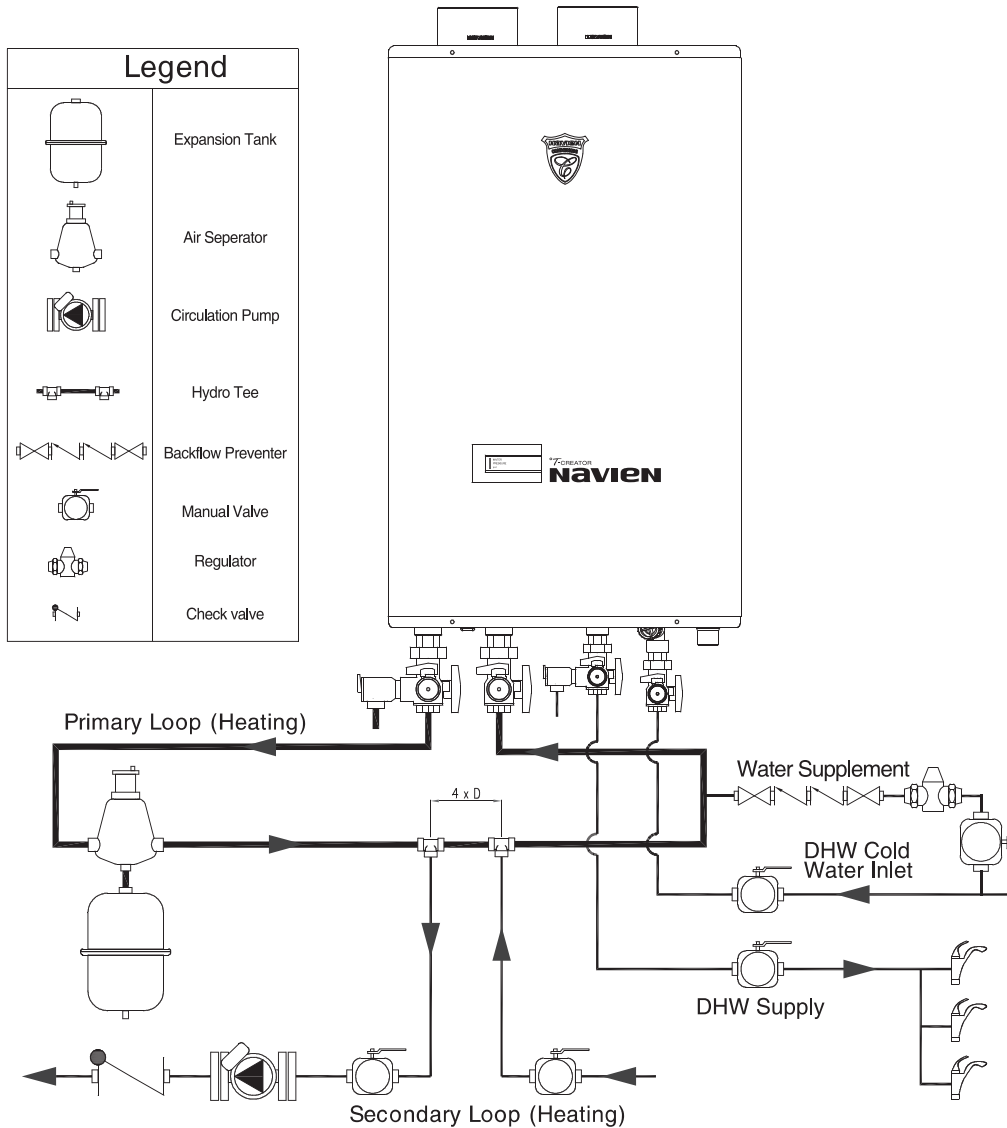

As shown above, Navien's have to establish the water supplement plumbing is not recommended.



### CAUTION

Do Not open the Auto Feeder Connection cap, unless the pipe is connected to the Auto Feeder valve.

# Plumbing:

## A. In-Floor Heating (Zoning Control) System (with Wiring Diagram)

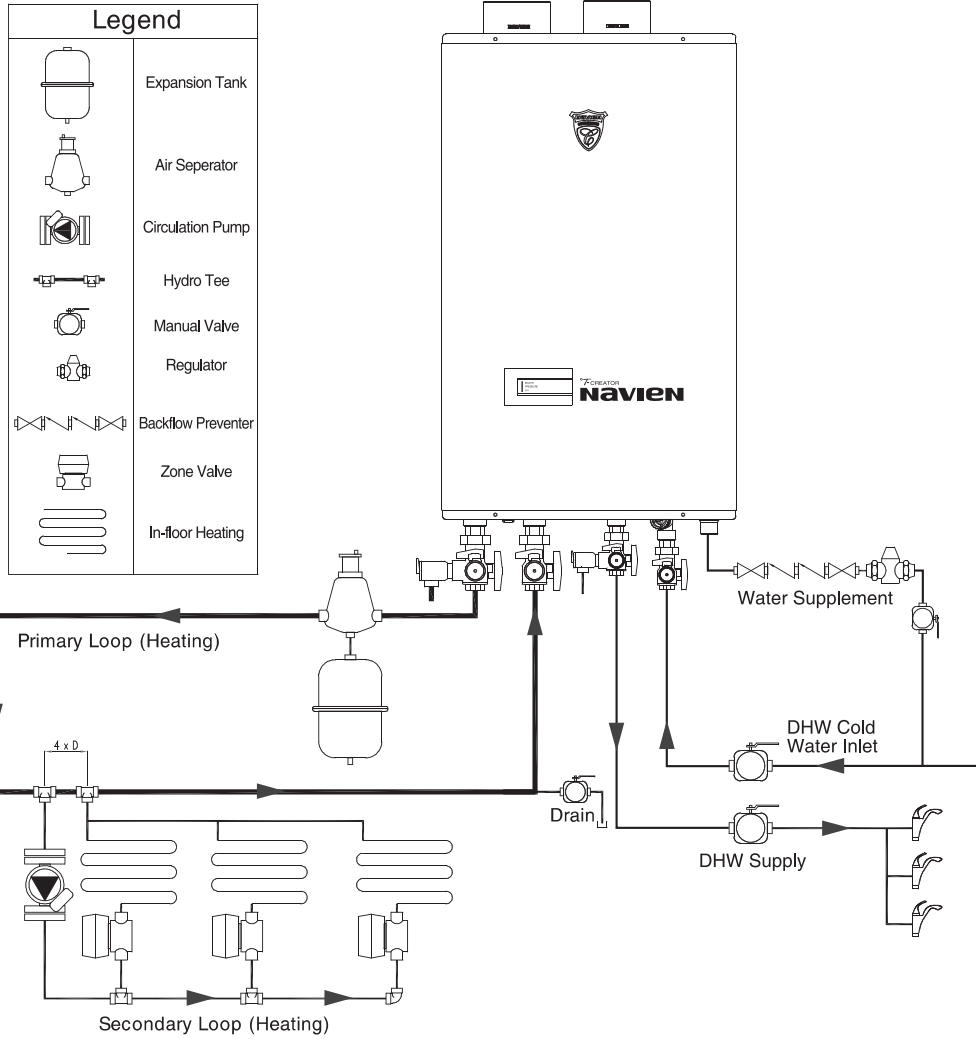

### Wiring Diagram

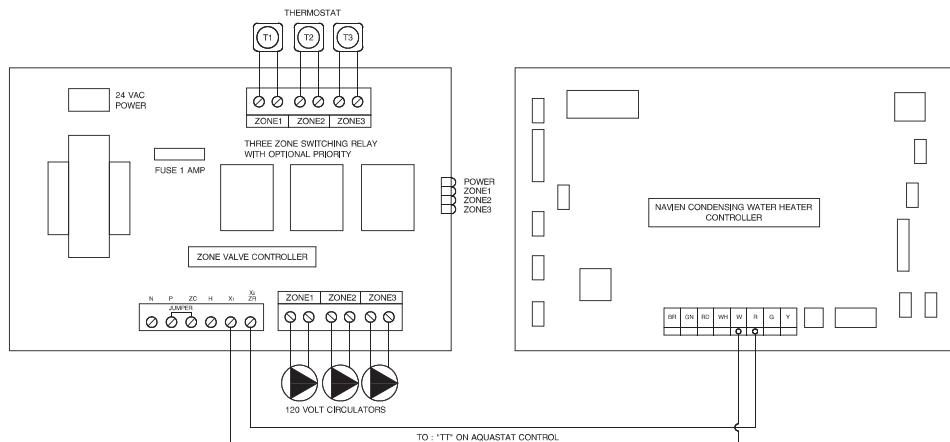



# Plumbing:

## B. In-Floor Heating System (Recovery Control)

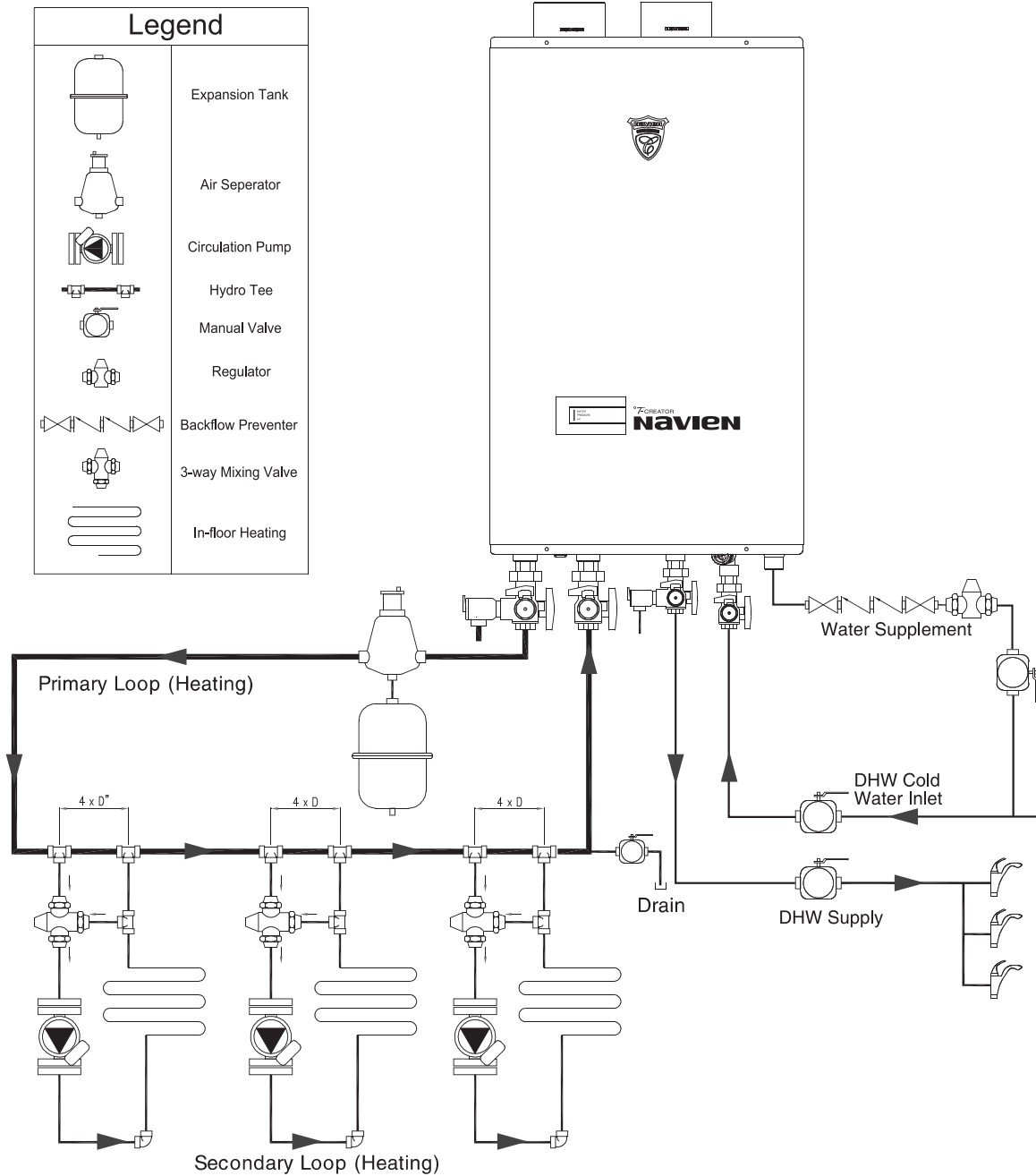

# Plumbing:

## C. Snow Melting System.

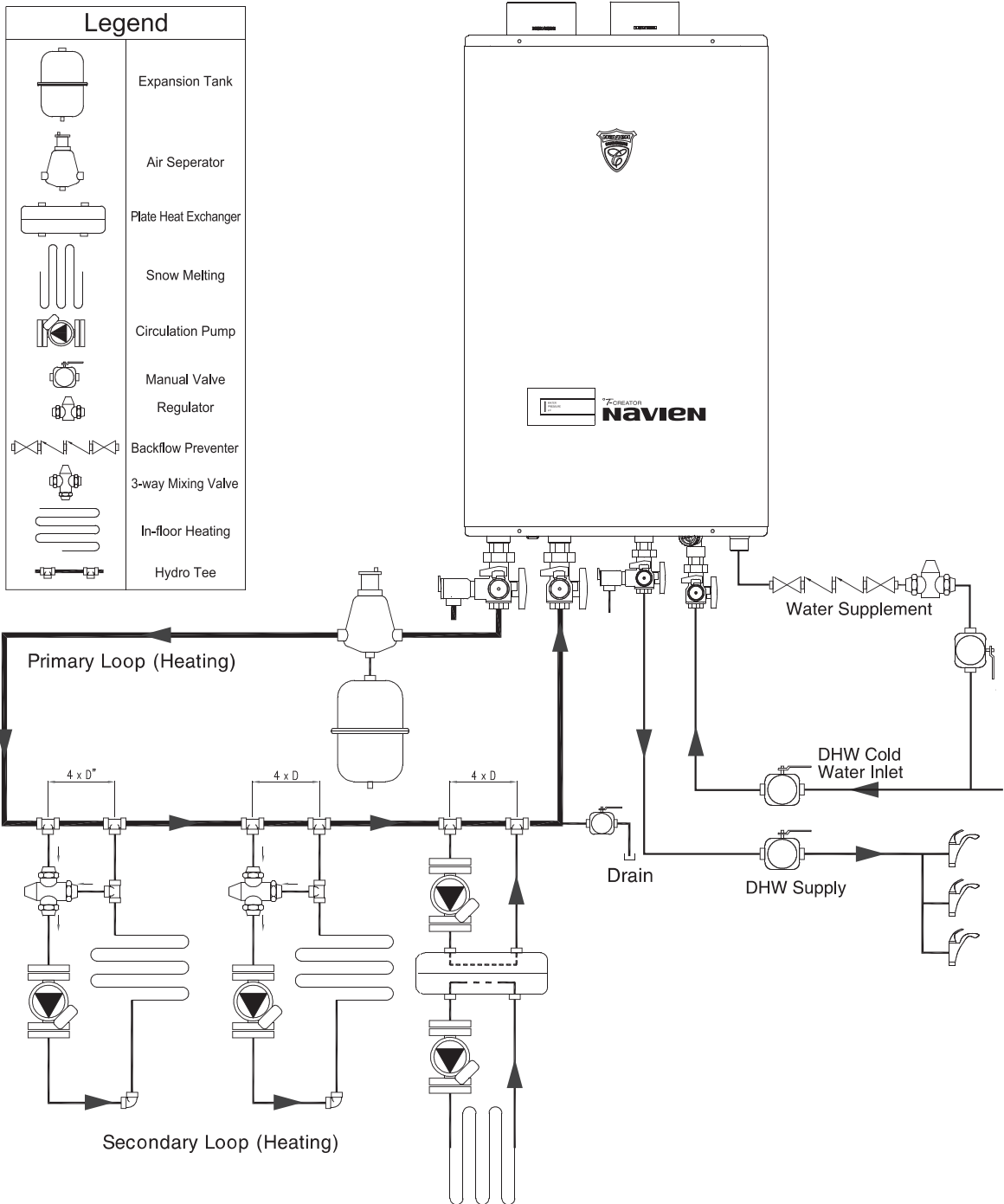





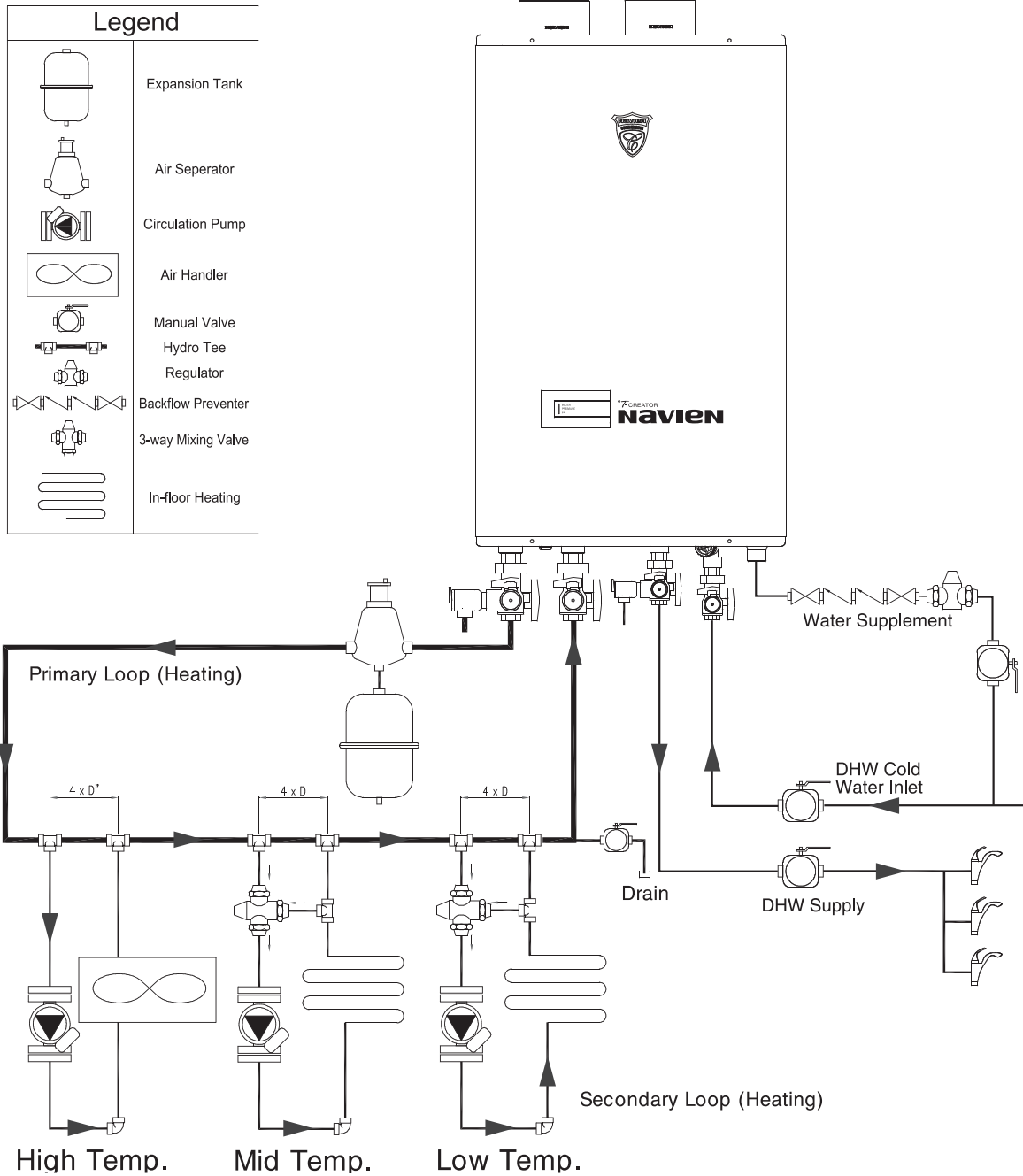



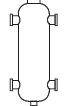

# Plumbing:

## D. High - Low Temperature System.



# Plumbing:





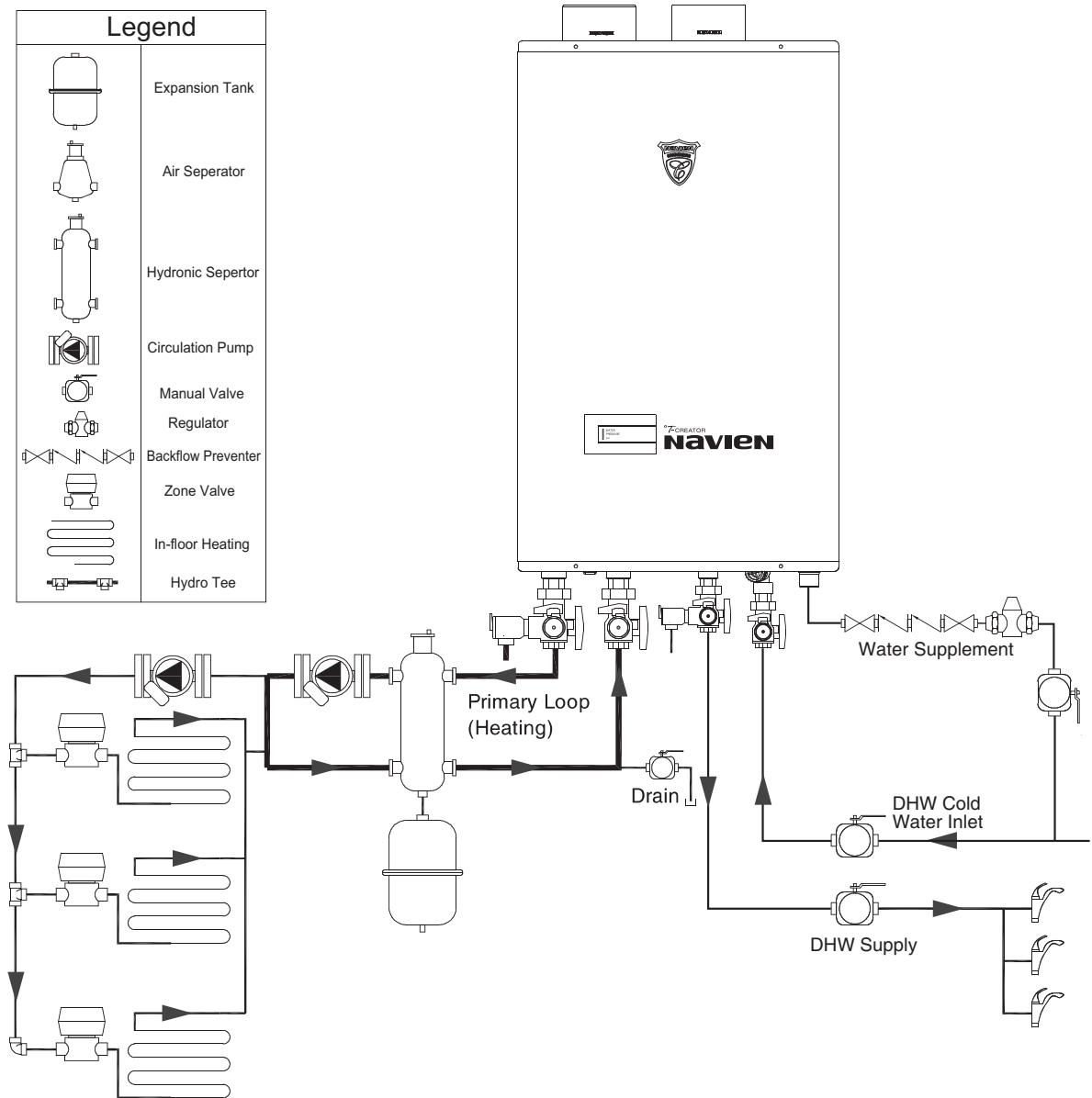

## E. Hydro - Separator System

Legend	
	Expansion Tank
	Air Separator
	Hydronic Separator
	Circulation Pump
	Manual Valve
	Regulator
	Backflow Preventer
	Zone Valve
	In-floor Heating
	Hydro Tee

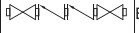

# Plumbing:

## F. Base Board System.

Legend			
	Expansion Tank		Manual Valve
	Air Separator		Regulator
	Base Board		Backflow Preventer
			Circulation Pump
			Hydro Tee

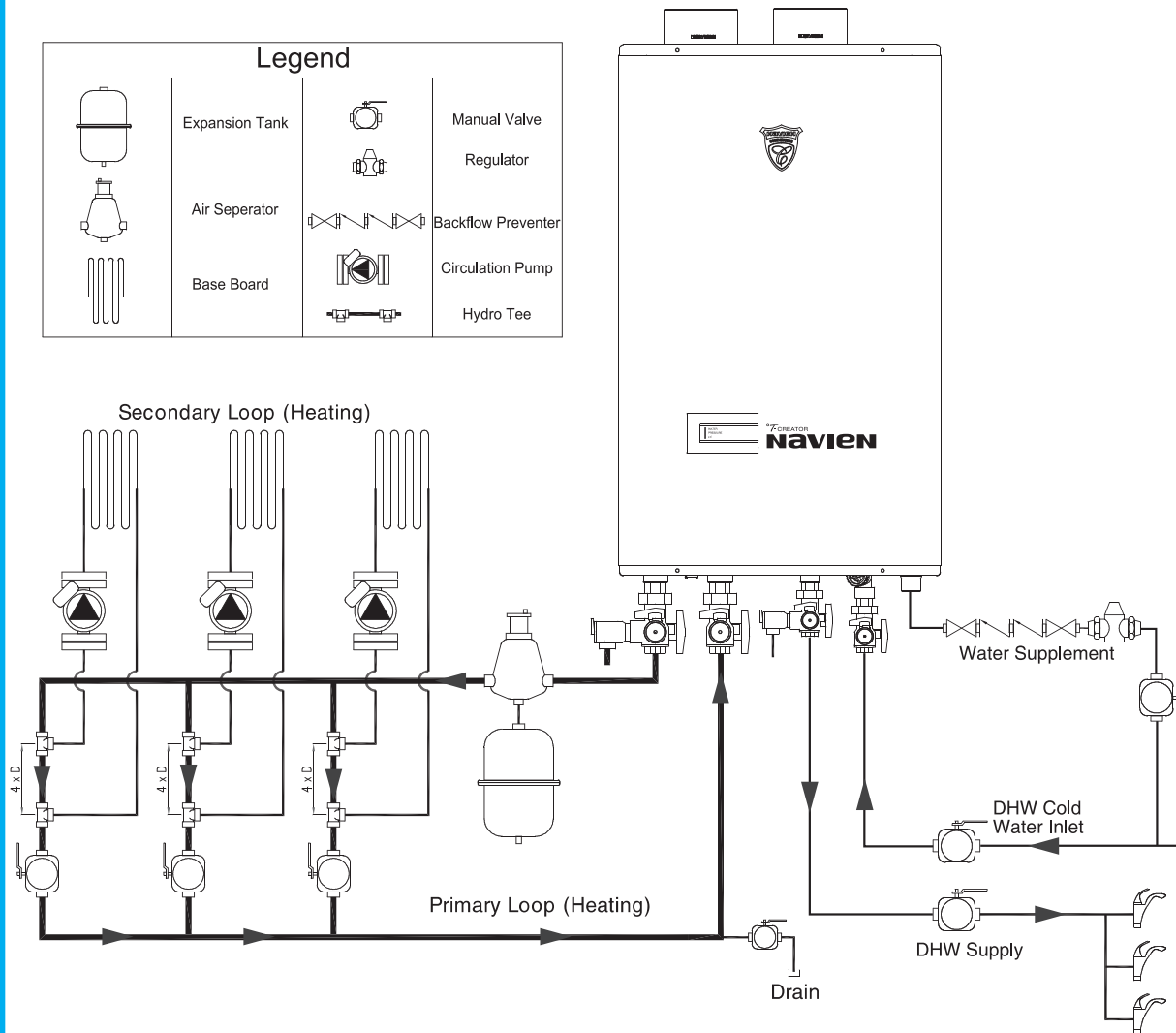

# Pressure Relief Valve:



## WARNING

Failure to comply with the guidelines on installing the pressure relief valve and discharge piping can result in personal injury, death or substantial property damage.

- ❑ An approved 3/4", maximum 150 psi pressure relief valve must be installed on the hot water outlet, as close to the unit as possible. Please see below for more information on approved pressure relief valves.
- ❑ An approved 1", maximum 30 psi pressure relief valve must be installed on the hot water outlet for hydronic space heating loop as close to the unit as possible. Please see below for more information on approved pressure relief valves.
- ❑ Each Navien combination Water Heater / Heating Boiler has a high-temperature shut off switch built in as a standard safety feature (called a temperature high limit switch) therefore a "pressure only" relief valve is required. This unit does not come with a pressure relief valve but one must be installed on the hot water outlet.
- ❑ The discharge capacity of the pressure relief valve must be at least equal to the maximum pressure rating of the combination Water Heater / Heating Boiler.
- ❑ The maximum input BTU rating on the valve must be equal to or greater than the maximum input BTU rating of the combination Water Heater / Heating Boiler.
- ❑ The discharge piping for the pressure relief valve must be directed so that the hot water cannot splash on anyone or on nearby equipment. Attach the discharge tube to the pressure relief valve and run the end of the tube to within 6" from the floor. This discharge tube must allow free and complete drainage without any restrictions. No reducing coupling or other restriction may be installed in the discharge line.
- ❑ The following 3/4", maximum 150 psi valves are examples of valves approved for use with all Navien products for domestic Hot water.

1. Wilkins P-1000A (Zurn Industries)
2. Conbraco 17-402-04
3. Watts Industries 3L (M7)
4. Cash Acme FWL-2 3/4"

- ❑ The following 1" space heating, maximum 30 psi valves are examples of valves approved for use with all Navien products for Hydronic space heating loop.

5. Wilkins P-1000A (Zurn Industries)
6. Conbraco RVW40
7. Watts Industries 374A
8. Cash Acme F30

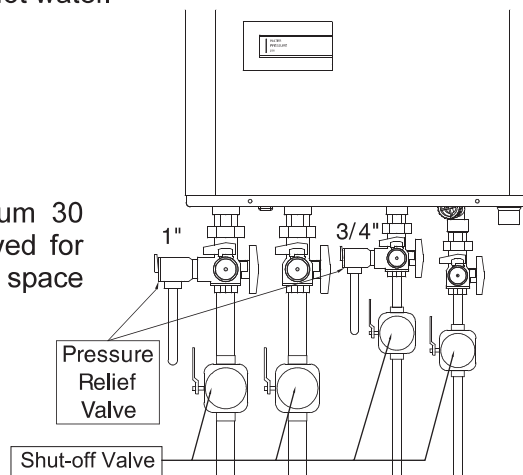

Instructions for pressure, temperature and vacuum relief valves shall specify that no valve is to be placed between the relief valve and the tank. The instructions shall specify installation in such a manner that the discharge from temperature and pressure relief valves will be conducted to a suitable place for disposal when relief occurs and that no reducing coupling or other restriction be installed in the discharge line.

# Disposal of Condensate:

## Disposal of Condensate

- ❑ This Navien combination Water Heater / Heating Boiler is a high efficiency gas appliance that creates condensation when it operates. Condensation has an acidic (pH) of approximately 3~4. Follow your local code with regards to the disposal of condensation. Here are several options for the Disposal of Condensate (see below):
  - ① From combination Water Heater / Heating Boiler direct to drain.
  - ② From combination Water Heater / Heating Boiler to neutralizer to drain.
  - ③ From combination Water Heater / Heating Boiler to laundry tub (bottom of combination Water Heater / Heating Boiler must be above the height of laundry tub; must have a negative slope to properly drain).
  - ④ From combination Water Heater / Heating Boiler to condensate pump to laundry tub (for long distances between combination Water Heater / Heating Boiler and laundry tub or when bottom of combination Water Heater / Heating Boiler is installed below height level of laundry tub).
- ❑ All Navien's CH model combination Water Heater / Heating Boilers are condensing gas appliances. A condensate trap comes factory installed inside each Water Heater / Heating Boiler.
- ❑ All condensate must be drained in accordance with all local regulations. Navien recommends draining the condensate to a laundry tub as the alkali in the detergent from the washing machine will neutralize the acid in the condensation. If a laundry tub is not close by, you may need to install a condensate pump to push the condensate to the nearest laundry tub or consider installing a condensate neutralizer so that you can release the neutralized (non-acidic) water into a regular, nearby drain.
- ❑ If a neutralizer is installed, periodic replacement of the lime stone (or neutralizing agent) will be required. The rate of depletion of the lime stone varies upon usage of the combination Water Heater / Heating Boiler. During the first year of operation, please check the neutralizer every few months for depletion. If you notice any depletion order some replacement neutralizer lime stone.
- ❑ Use only corrosion-resistant materials for the condensate drain lines such as 3/4" ID PVC pipe vinyl or plastic hose.

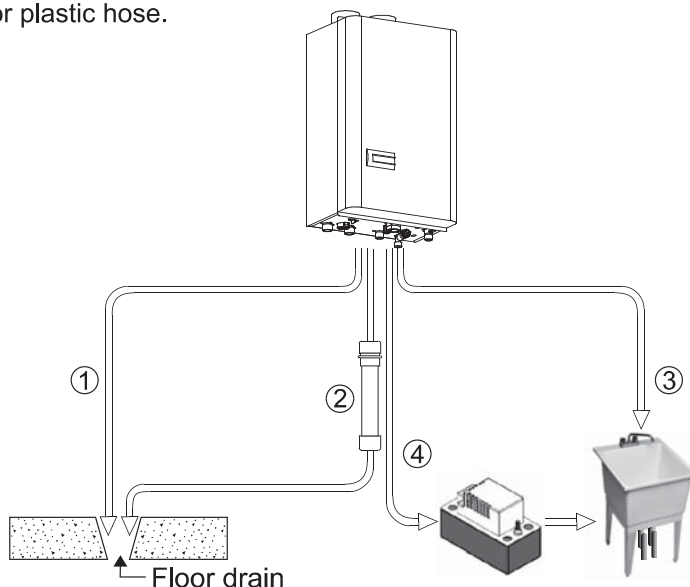

## Condensate Drain & Cleaning:

### Condensate Drain

- ❑ A condensate drain tube is included with the Navien Water Heater / Heating Boiler. This tube must be connected to the port at the bottom of the unit (see figure below). The end of the tube should drain to a laundry tub or to a floor drain. If additional tubing is required, any  $\frac{3}{4}$ " polyvinyl tubing should suffice.

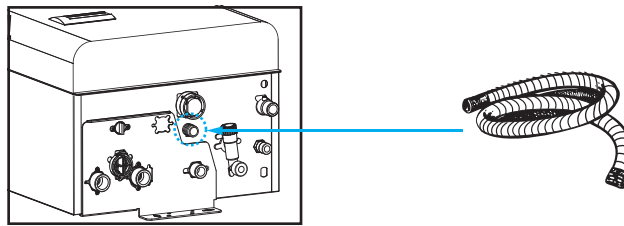

- ❑ Over time, blockage of the siphon by debris may occur. When the condensate cannot be released, the Water Heater / Heating Boiler will go into error and will shut down. When this occurs, the siphon must be cleaned. To clean, you will need a bucket to collect any residual water. (See figures below)

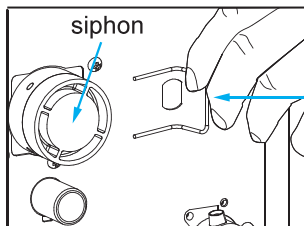

Remove retaining syphon clip

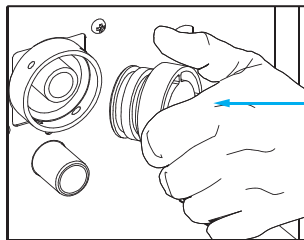

Prepare bucket, twist and remove cap, drain, clean out syphon and re-insert cap **and retaining syphon clip.**

- ❑ Once the cap and clip have been re-inserted, the syphon must be re-filled. See figure below.

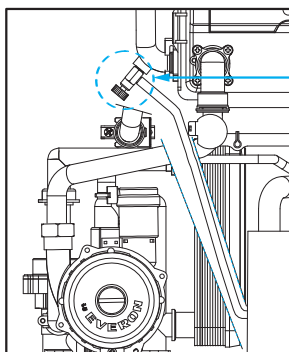

- Open the valve and water will begin to fill in the syphon. Fill the syphon to the top and then close the valve.
- Open a hot water faucet; examine the open end of the condensate drain line to ensure no flue gases are exiting from that pipe. If the flue gases are exiting, immediately stop the unit and call Navien for additional instructions.



# Gas Piping:

## Gas Piping Guidelines:

- ❑ Navien recommends the combination Water Heater / Heating Boiler be the first appliance installed downstream of the gas meter to ensure it will have sufficient gas supply.

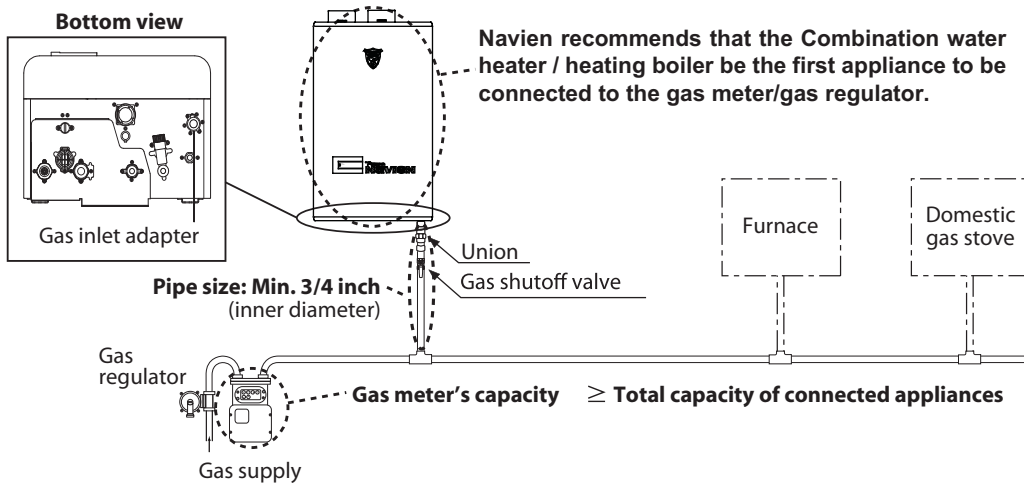

- ❑ Use the charts on the following pages to properly size the gas supply line.
- ❑ The gas connection fitting on all Navien units is 3/4". **DO NOT** use less than 3/4" piping.
- ❑ When using flexible gas line, ensure the pipe's inner diameter is sufficient to supply the required BTUs, also ensure that the flexible line has no crimps or tight bends as this will restrict gas flow.
- ❑ Install a manual gas shut-off valve on the gas supply line and the Water Heater / Heating Boiler.
- ❑ When using rigid pipe, Navien recommends the installing a union on the gas supply line close to the Water Heater / Heating Boiler to facilitate any future maintenance and service.
- ❑ A sediment trap must be provided upstream of the gas controls.
- ❑ LP Gas Piping Installatinon
  - . Regular System

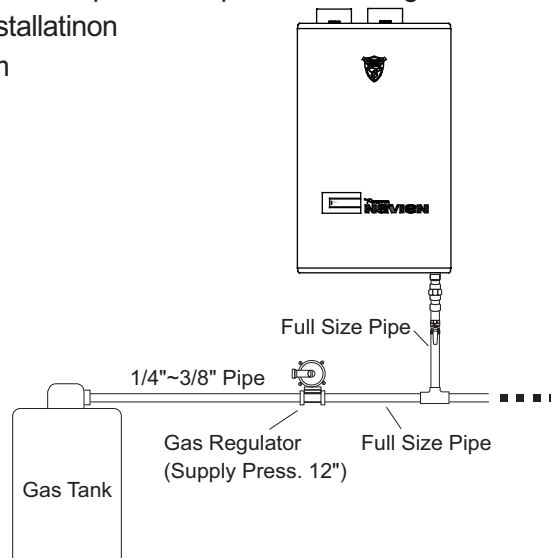

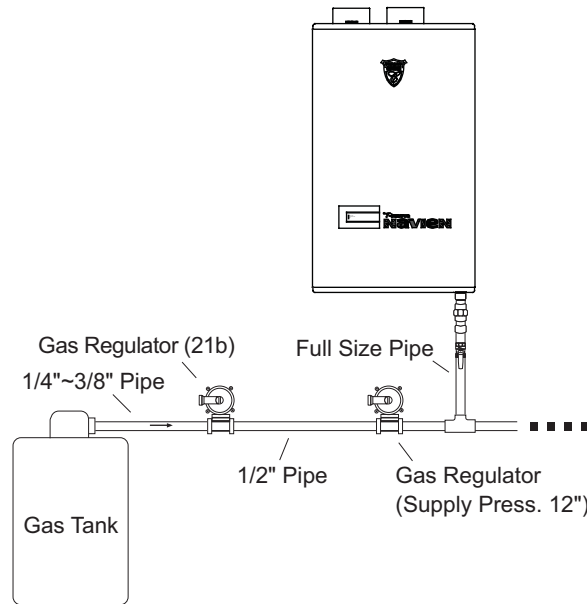
**- 2lb System**

## Gas Supply Line Pressures:

1. The minimum and maximum inlet gas pressures are:  
**Natural Gas Min. 3.75" WC - Max. 10.5" WC**  
**Propane Gas Min. 10.5" WC ~ Max. 13.5" WC**
2. Gas pressures over and above the specified ranges will result in adverse performance and dangerous operating conditions; any damage resulting from extreme gas supply pressures will not be covered by the limited warranty.
3. Until pressure testing of the main gas supply line is completed, ensure the gas line to the Navien Combination Water Heater / Heating Boiler is disconnected to avoid any damage to the Water Heater / Heating Boiler.
4. The appliance must be isolated from the gas supply piping system by closing its individual manual shut-off valve during any pressure testing of the gas supply system at test pressures equal to or less than 0.5 psi (3.5 kPa).
5. The gas appliance and its gas connections must be leak tested before placing the appliance in operation. Leaks can be found by using a gas leak detection device or by applying soapy water to all gas fittings. Should bubbles occur tighten those connections and re-test.
6. Always purge the gas line for any debris before connecting to the Water Heater / Heating Boiler gas inlet.
7. Never use an open flame to test for gas leaks as property damage, personal injury or death could result.

# Gas Pipe Sizing Chart:

Referenced from Uniform Plumbing Code 1997

## Maximum Natural Gas Delivery Capacity

in Cubic Feet (ft<sup>3</sup>) per Hour (0.60 Specific Gravity, 0.5" WC Pressure Drop)

Pipe Size	Length in Feet											
	10'	20'	30'	40'	50'	60'	70'	80'	90'	100'	125'	
3/4"	363	249	200	171	152	138	127	118	111	104	93	
1"	684	470	377	323	286	259	239	222	208	197	174	
1 1/4"	1,404	965	775	663	588	532	490	456	428	404	358	
1 1/2"	2,103	1,445	1,161	993	880	798	734	683	641	605	536	
2"	4,050	2,784	2,235	1,913	1,696	1,536	1,413	1,315	1,234	1,165	1,033	
2 1/2"	6,455	4,437	3,563	3,049	2,703	2,449	2,253	2,096	1,966	1,857	1,646	
3"	11,412	7,843	6,299	5,391	4,778	4,329	3,983	3,705	3,476	3,284	2,910	
3 1/2"	16,709	11,484	9,222	7,893	6,995	6,338	5,831	5,425	5,090	4,808	4,261	
4"	23,277	15,998	12,847	10,995	9,745	8,830	8,123	7,557	7,091	6,698	5,936	

Contact your gas supplier for BTU/ft<sup>3</sup> rating. Use 1000 BTU/ft<sup>3</sup> for implied calculation.

## Maximum Liquefied Propane Delivery Capacity

in Thousands of BTU/Hour(0.5" WC Pressure Drop)

Pipe Size	Length in Feet												
	10'	20'	30'	40'	50'	60'	70'	80'	90'	100'	125'	150'	200'
3/4"	567	393	315	267	237	217	196	185	173	162	146	132	112
1"	1,071	732	590	504	448	409	378	346	322	307	275	252	213
1 1/4"	2,205	1,496	1,161	993	880	798	734	683	641	605	536	477	418
1 1/2"	3,307	2,299	1,811	1,547	1,380	1,254	1,154	1,073	1,000	943	827	741	646
2"	6,221	4,331	3,363	2,841	2,514	2,274	2,099	1,954	1,830	1,723	1,533	1,377	1,200

\*\*For reference only. Please consult gas pipe manufacturer for actual pipe capacities.

## Maximum Natural Gas Delivery Capacity with Corrugated Stainless Steel Pipe

in Cubic Feet (ft<sup>3</sup>) per Hour (0.60 Specific Gravity, 0.5" WC Pressure Drop)

Pipe Size	Length in Feet												
	10'	20'	30'	40'	50'	60'	70'	80'	90'	100'	150'	200'	
3/4"	206	147	121	105	94	86	80	75	71	67	55	48	
1"	383	269	218	188	168	153	141	132	125	118	94	82	
1 1/4"	614	418	334	284	251	227	209	194	181	171	137	116	
1 1/2"	1,261	888	723	625	559	509	471	440	415	393	320	277	
2"	2,934	2,078	1,698	1,472	1,317	1,203	1,114	1,042	983	933	762	661	

## Maximum Liquefied Propane Delivery Capacity with Corrugated Stainless Steel Pipe

in Thousands of BTU/Hour(0.5" WC Pressure Drop)

Pipe Size	Length in Feet												
	10'	20'	30'	40'	50'	60'	70'	80'	90'	100'	150'	200'	
3/4"	325	232	191	166	149	136	126	118	112	106	87	76	
1"	605	425	344	297	265	241	222	208	197	186	143	129	
1 1/4"	971	661	528	449	397	359	330	307	286	270	217	183	
1 1/2"	1,993	1,404	1,143	988	884	805	745	696	656	621	506	438	
2"	4,638	3,285	2,684	2,327	2,082	1,902	1,761	1,647	1,554	1,475	1,205	1,045	

\*\* For reference only. Please consult gas pipe manufacturer for actual pipe capacities.

# Measuring Inlet Gas Pressure:

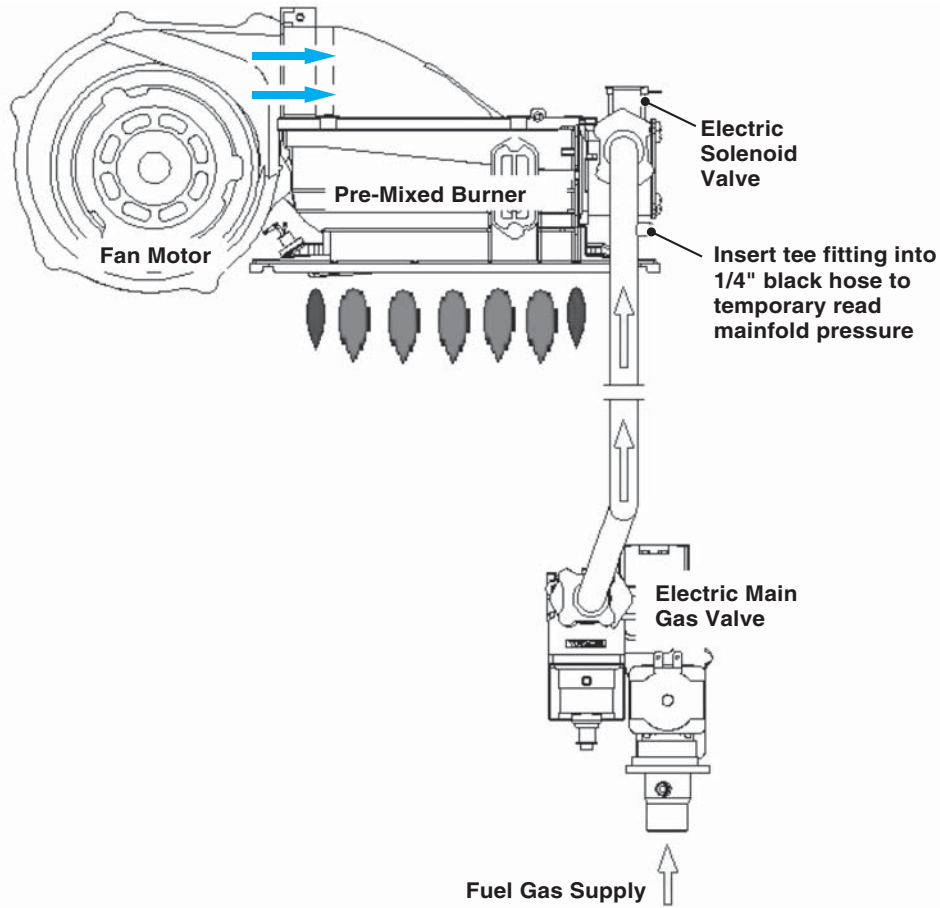

The Navien Combination Water Heater / Heating Boiler cannot operate properly without sufficient inlet gas pressure and volume. Below are instructions on how to check the inlet gas pressure.

 **CAUTION**

**THIS IS ONLY TO BE DONE BY A LICENSED PROFESSIONAL**

### Procedure to measure the inlet gas pressure:

1. Shut off the manual gas valve on the supply line.
2. Open a hot water faucet. The unit should turn on and the gas in the gas pipe line should purge. Leave the faucet on to keep the unit running until the unit shuts down due to lack of gas supply. Then shut off the hot faucet.
3. Remove the screw for the pressure port located on the gas inlet of the Water Heater / Heating Boiler.

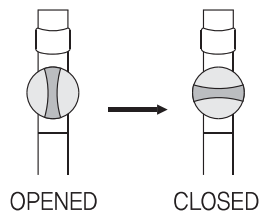

## Measuring Inlet Gas Pressure:

Pressure test port on gas line

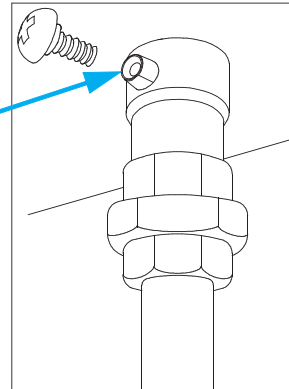

4. Connect a manometer to the pressure port and reset it to zero.
5. Re-open the manual gas valve. Check to see that there are no gas leaks.
6. Open multiple fixtures that have high flow rates ( i.e. bathtub, showers, kitchen sink) to ramp the Water Heater / Heating Boiler up to its maximum burn.
7. When the Navien Water Heater / Heating Boiler is at maximum burn, check the inlet gas pressure reading on the manometer, it should read between 3.75" and 10.5"WC for Natural Gas / 10.5" and 13.5"WC for Propane gas.
8. The maximum inlet gas pressure must not exceed the value specified by the manufacturer and that the minimum value listed is for the purposes of input adjustment.
9. The Water Heater / Heating Boiler and individual shutoff valve must be disconnected from the gas supply piping system during any pressure testing of that system at test pressures in excess of 1/2 psi (3.5 kPa).
10. The Water Heater / Heating Boiler must be isolated from the gas supply system by closing its individual manual shutoff valve during any pressure testing of the gas supply piping system at test pressures equal to or less than 1/2 psi (3.5 kPa).

## Venting:



### WARNING

Improper venting of combination Water Heater / Heating Boiler can result in excessive levels of carbon monoxide which can result in severe personal injury or death. This combination Water Heater / Heating Boiler must be vented in accordance with the "Venting of Equipment" section of the latest edition of the ANSI Z223.1 / NFPA 54 Natural Fuel Gas Code and/or the "Venting systems and air supply for appliances" section of the latest version of the CAN/CGA B149.1 Natural Gas and Propane Installation Code in Canada and in accordance with all applicable local building codes.



### WARNING

This Navien Combination Water Heater / Heating Boiler can be vented with (PVC) plastic. PVC Vent can be used in all cases up to Exhaust flue gas temperature 149°F(65°C). **IF** you set the Water Heater / Heating Boiler at a temperature higher than 160°F (70°C) **AND** are running an combination heating system, you **MUST** use plastic venting (CPVC sch80) or any 3" venting system approved for use with Category IV appliances (typically Type BH Special Gas Vent approved to UL1738-S636).

## Venting Guidelines

- For best results, keep the vent system as short and straight as possible.
- Locate the combination Water Heater / Heating Boiler as close as possible to the vent terminator.
- The combination Water Heater / Heating Boiler vent must not be common vented with any other gas appliance or vent stack.
- Slope the vent toward the vent terminal at a rate of 1/4" per foot (2% slopes).
- When slopping the vent using any other manufacturer's stainless steel vent, the assembly of the vent pipe must be such that it is male-to-female in the direction of the flow of condensate.
- The exhaust pipe and intake air pipe must be sealed air tight at each joint from exhaust pipe to terminator.
- Make sure that the seam of the vent pipe in horizontal runs toward the top of the installation.

**Note:** To avoid moisture and frost build-up and to maintain clearances to openings on adjacent homes, 45° elbows, 90° elbows or tees may be attached to the end of the termination vent pipe to direct the exhaust plumes away from any adjacent house as long as the total allowable vent lengths, maximum number of elbows and distance to air intake restrictions are observed.

## Venting:

- ❑ Do not store hazardous or flammable substances near the vent terminator.
- ❑ If this product will be installed in an area where snow is known to accumulate, protect the vent termination from blockage.
- ❑ Vent terminator must be a minimum of 12" above ground.
- ❑ Support the vent pipe with hangers at regular intervals or as required by local code; the weight of the vent pipe must not rest on the Water Heater / Heating Boiler.
- ❑ Exhaust pipe and intake air pipe must be supported every 5 feet.
- ❑ The installation of the venting system shall specify that the horizontal portions of the venting system shall be supported to prevent sagging;
  - Have horizontal runs sloping upwards not less than 1/2 inch per foot from the water heater/boiler to the vent terminal;
  - Be installed so as to prevent accumulation of condensate; and
  - Where necessary, have means provided for drainage of condensate.

### **Navien and Direct Vent:**

- ❑ All Navien Combination Water Heater / Heating Boilers are prepared at the factory to be direct vent (sealed combustion) units which draw all of their required combustible air directly from outside the building.
- ❑ All Navien Combination Water Heater / Heating Boilers use 3" diameter exhaust and 3" diameter intake air duct. To ensure the draw and exhaust of air directly to and from the outside, the exhaust pipe and intake air duct must be sealed airtight from unit collar to terminator.
- ❑ **The air intake vent materials** can be made of ABS, PVC, galvanized steel, corrugated aluminum or any other such materials. If you are using a corrugated material, ensure there is no inadvertent crimping of, or damage to, the intake air pipe.

### **Navien and Non-Direct Vent:**

- ❑ Navien recommends direct vent installations whenever possible to avoid back drafting cold air through the unit, if you cannot use direct vent, it is essential to have an ample supply of make-up air.
- ❑ If at any time, the building experiences a negative pressure situation when using a non-Direct Vent unit, there is a possibility of back drafting cold, winter air from outside through the heat exchanger of the Water Heater / Heating Boiler. This situation may freeze the Water Heater / Heating Boiler's heat exchanger. According to the building codes in most jurisdictions, a negative pressure in homes is not allowed. In a home with a well-balanced air supply, freezing of the heat exchanger will not occur.
- ❑ Since the cause of the back drafting is insufficient make-up air within the home or building. This will not be deemed a manufacturing problem and any freezing damage which occurs from back drafting will not be covered under warranty. To avoid any such issues in colder climates, Navien requires the use of direct vent.

## Venting:

- ❑ To fit the unit for non-direct venting, insert the termination end cap (provided with the Water Heater / Heating Boiler) into the intake air duct. Do not glue to allow for easy removal and cleaning of the cap.

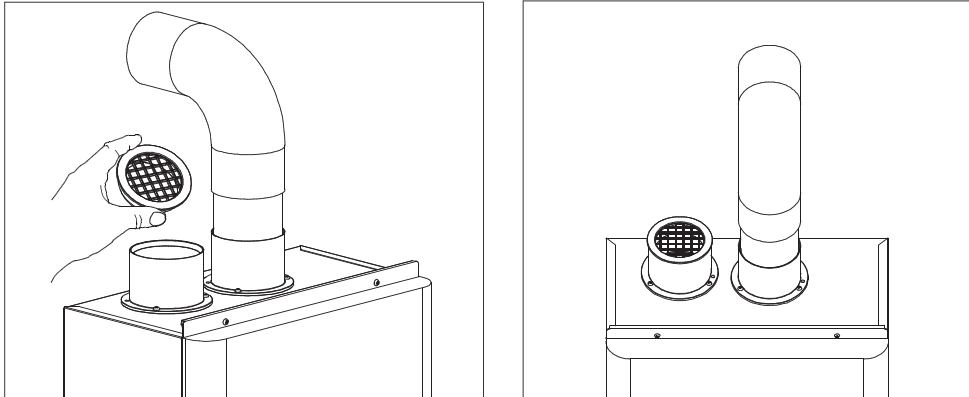

### Combustion Air Supply Requirement for Non-Direct Vent:

- ❑ When a Navien Combination Water Heater / Heating Boiler is installed without a dedicated intake air pipe (non-Direct Vent) communicating directly with the outdoors, combustion air must be supplied to the space. The opening sizes below are Navien's minimum requirements. Follow the latest version of the National Fuel Gas Code (ANSI Z223.1 / NFPA 54) or CAN/CGA B-149.1.

Model	CH-180	CH-210	CH-240
Maximum Input (BTU)	150,000	175,000	199,000
Outdoor make up air is provided, a <u>minimum free area</u> of 1 in <sup>2</sup>	5.3 in <sup>2</sup> 3" (W) x 2" (H) or 3" round	6.1 in <sup>2</sup> 2.5" (W) x 2.5" (H) or 3" round	7 in <sup>2</sup> 2¾" (W) x 2¾" (H) or 3" round
Indoor make up air is provided, a <u>minimum free area</u> of 1 in <sup>2</sup>	150 in <sup>2</sup> 12¼" (W) x 12¼" (H)	175 in <sup>2</sup> 13¼" (W) x 13¼" (H)	199 in <sup>2</sup> 14¼" (W) x 14¼" (H)

Have to enough make up air for all other gas appliances that may be located in the vicinity as well.



# Venting:

## Contaminated Make-up Air Will Damage the Unit

- Do not operate the combination Water Heater / Heating Boiler in an area that is or will be under construction or renovation.
- Do not install the combination Water Heater / Heating Boiler in an area with contaminated air (containing a high level of dust, sawdust, sand, flour, aerosols or any other such airborne contaminants) as those contaminants will cause operational problems.
- The Navien warranty will not cover damage caused to the unit due to installation in a contaminated environment.
- To minimize operational problems, direct venting (sealed combustion) must be used such that contaminant free combustion air will be supplied directly from outside. Even with direct venting, regular filter cleaning and maintenance is recommended for these types of environments.

## Exhaust Gas Pipe Materials

- Venting requirements in USA and Canada are different. Please consult the chart below and the most recent edition of the National Fuel Gas Code (ANSI Z223.1 / NFPA 54) or CAN/CGA B-149.1 as well as local codes for applicable venting regulations and restrictions;
- All Navien Water Heater / Heating Boilers are Category IV appliances;

Navien Recommended Vent Materials		
Model Type	USA	CANADA
CH-180 CH-210 CH-240	PVC Schedule 40 ABS Schedule 40	Navien's Stainless Steel Vent Kit or Type BH Special Gas Vent Class IIB (PVC)

- Navien does NOT recommend the use of cellular core ABS as venting on any of its products.
- When using stainless steel BH type gas vent, the exhaust vent system must be sealed air tight and must be male-to-female in the direction of the flow of condensate. Follow the vent pipe manufacturer's certified installation instructions.

### A New requirement for Canada

For installation in Canada, field supplied plastic vent piping must comply with CAN/CGA B149.1 (latest edition) and be certified to the Standard For Type BH Gas Venting Systems, ULC **S636** Components of this listed system shall not be interchanged with other vent systems or unlisted pipe/fittings. All plastic components and specified primers and glues of the certified vent system must be from a single system manufacturer and not intermixed with other system manufacturer's vent system parts. The supplied vent connector and vent termination are certified as part of the combination Water Heater / Heating Boiler.

# Venting Clearances:

All clearance requirements are in accordance with ANSI Z21.10.3 and the National Fuel Gas Code, ANSI Z223.1 / NFPA 54 and CGA B149.1 Natural Gas and Propane Installation Code.

ANSI Z233.1 / NFPA 54 and CGA B149.1 Natural Gas and Propane Installation Code.

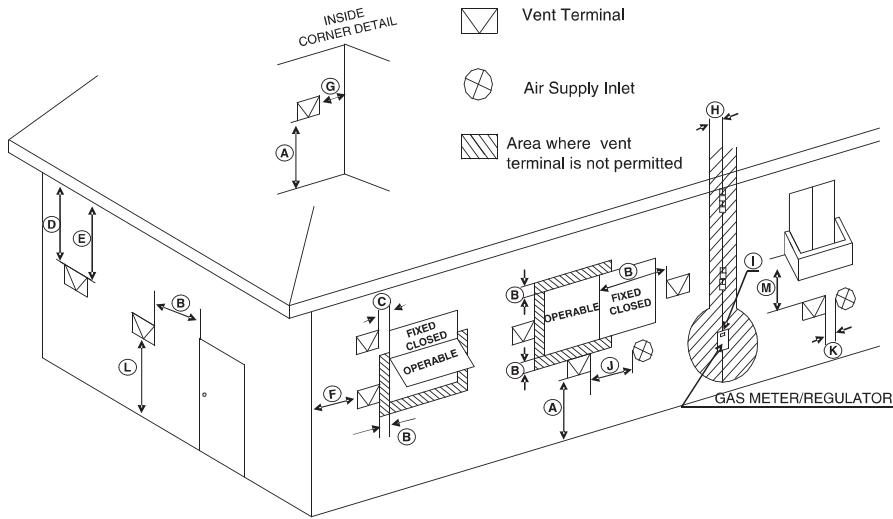

	Clearance To:	US Direct Vent Indoor Installation	Canada Direct Vent Indoor Installation
<b>A</b>	Above grade, veranda, porch, deck or balcony	1'	1'
<b>B</b>	Window or door that may be opened	4'	3'
<b>C</b>	Permanently closed window	*	*
<b>D</b>	Vertical clearance to ventilated soffit located above the terminal within a horizontal distance of 2 feet from the center of the terminal	*	*
<b>E</b>	Unventilated soffit	*	*
<b>F</b>	Outside corner	*	*
<b>G</b>	Inside corner	*	*
<b>H</b>	Each side of center line extended above meter/regulator assembly	*	3' within a height 15' above meter/regulator assembly
<b>I</b>	Service regulator vent outlet	*	3'
<b>J</b>	Non-mechanical air supply inlet or combustion air inlet to any other appliance	1'	3'
<b>K</b>	Mechanical air supply inlet	3' above if within 10' horizontally	6'
<b>L</b>	Above paved sidewalk or paved driveway located on public property	*	7'
<b>M</b>	Under veranda, porch, deck, or balcony	*	1'

## Venting:

### Allowable 3" Vent Lengths

MODEL	MAX LENGTH	MAX # of ELBOWS	EQUIVALENT LENGTHS
180	100'	6	Reduce the maximum vent length accordingly for each elbow used: Each 90° elbow equates to 5 linear feet of vent. Each 45° elbow equates to 2 linear feet of vent.
210	100'	6	
240	100'	6	
<b>NOTE: The maximum lengths listed above are for the exhaust pipe section only. The intake air pipe length can be of equal length. The maximum lengths are not including elbows.</b>			

### Allowable 2" Venting

The 2" diameter Sch 40 PVC venting pipe installation is a maximum 12 feet, plus 1 elbow and elbow termination (2 elbows total) up to 2,000 feet elevation. Installations above 2,000 feet require all 3" venting.

MODEL	MAX LENGTH	MAX # OF ELBOWS	REMARK
180	12'	2	Type BH Special gas Vent Class IIA(PVC) for Canada
210	12'	2	
240	12'	2	

**When an existing Water heater/boiler is removed from a common venting system, the common venting system is likely to be too large for proper venting of the appliances remaining connected to it.**

#### Test Procedure to common vent system

1. Seal any unused openings in the common venting system.
2. Visually inspect the venting system for proper size and horizontal pitch and determine there is no blockage or restriction, leakage, corrosion and other deficiencies which could cause an unsafe condition.
3. Insofar as is practical, close all building doors and windows and all doors between the space in which the appliances remaining connected to the common venting system are located and other spaces of the building. Turn on clothes dryers and any appliance not connected to the common venting system. Turn on any exhaust fans, such as range hoods and bathroom exhaust, so they will operate at maximum speed. Do not operate a summer exhaust fan. Close fireplace dampers.
4. Place in operation the appliance being inspected. Follow the lighting instructions. Adjust thermostat so appliance will operate continuously.
5. Test for spillage at the draft hood relief opening after 5 minutes of main burner operation. Use the flame of a match of candle, or smoke from a cigarette, cigar or pipe.
6. After it has been determined that each appliance remaining connected to the common venting system properly vents when tested as outlined above, return door, windows, exhaust fans, fireplace dampers and any other gas burning appliance to their previous condition of use.

# Venting

- Any improper operation of the common venting system should be corrected so the installation conforms with the National Fuel Gas Code, ANSI Z223.1/NFPA 54 and/or CAN/CSA B149.1, Natural Gas and Propane Installation Code. When resizing any portion of the common venting system, the common venting system should be resized to approach the minimum size as determined using the appropriate tables in Part 11 of the National Fuel Gas Code, ANSI Z223.1/NFPA 54 and/or CAN/CSA B149.1, Natural Gas and Propane Installation Code.

## Vent Configuration Options:

The following diagrams represent some typical venting configurations and are included to assist you in designing your vent system. Possible configurations are not limited to these diagrams.

### Option #1: 3" 2-pipe side wall vent

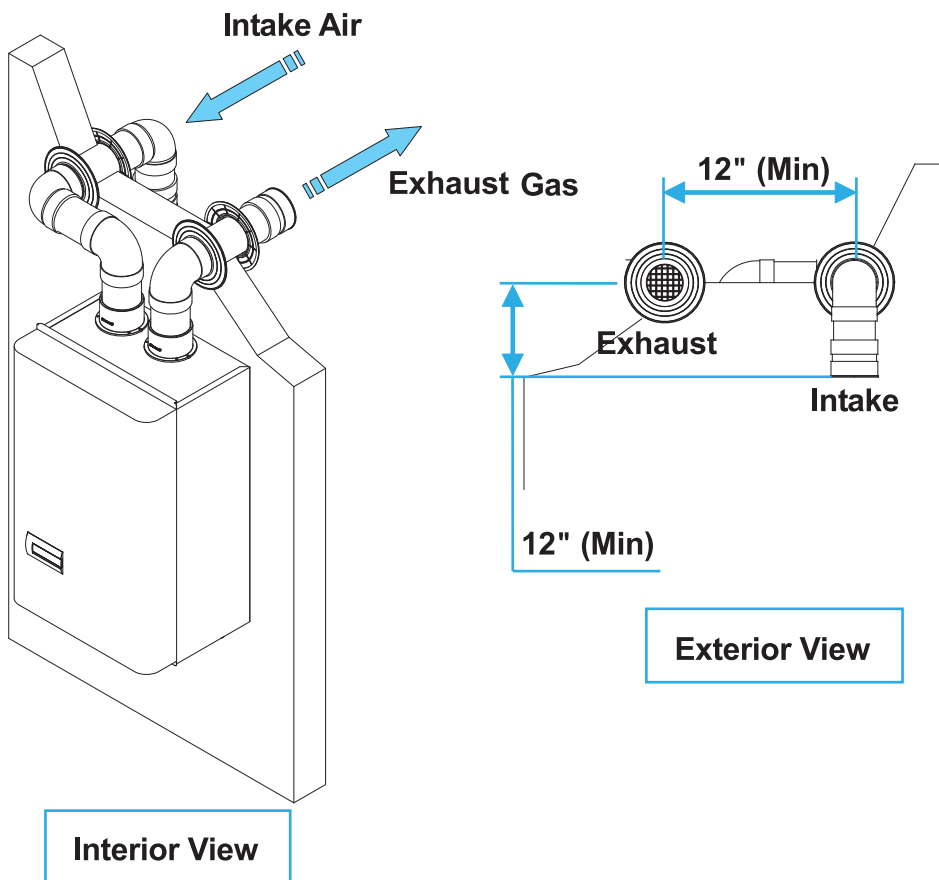

**Option #2:** Non-concentric venting through a side wall. Air is drawn from different location at a **minimum** of 12" from the termination. Please try to minimize the length of the intake air pipe length.

# Venting:

## Option #3: 3" 2-Pipe Vertical Vent Termination

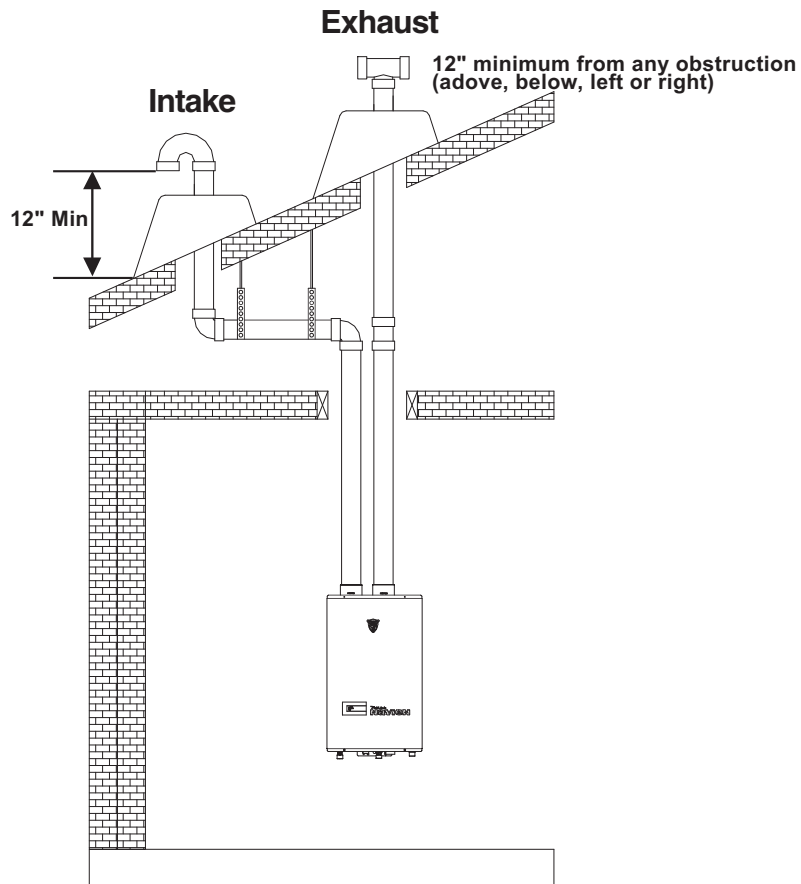

# Venting:

## CONCENTRIC VENT TERMINATION

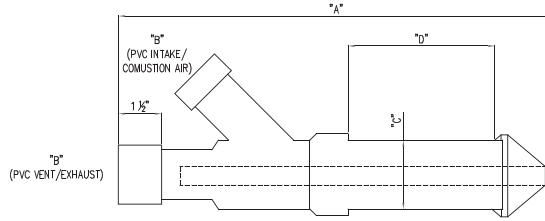

	"A"	"B"	"C"	"D"
DIMENSION	38- 7/8"	3"	4- 1/2"	21- 1/8"

### 1. Sidewall Installation

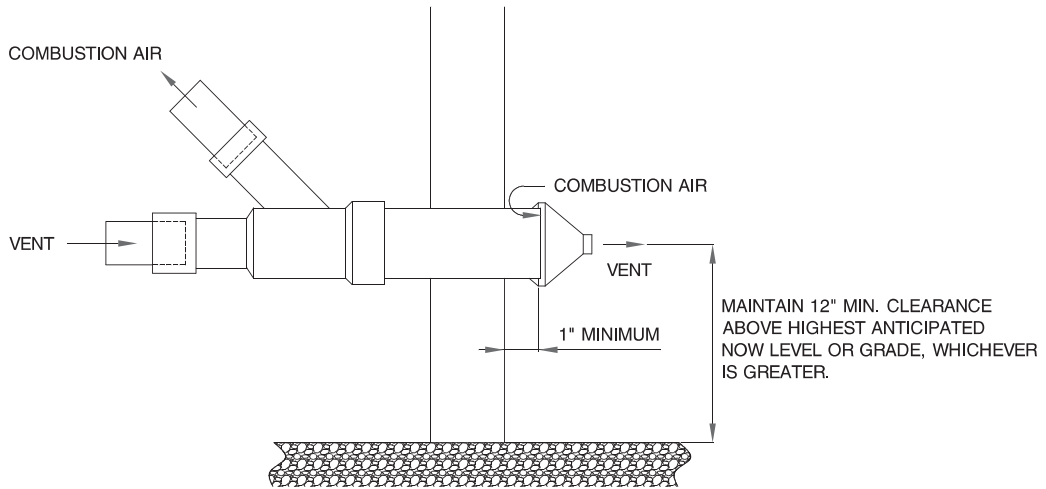

### 2. Roof Installation

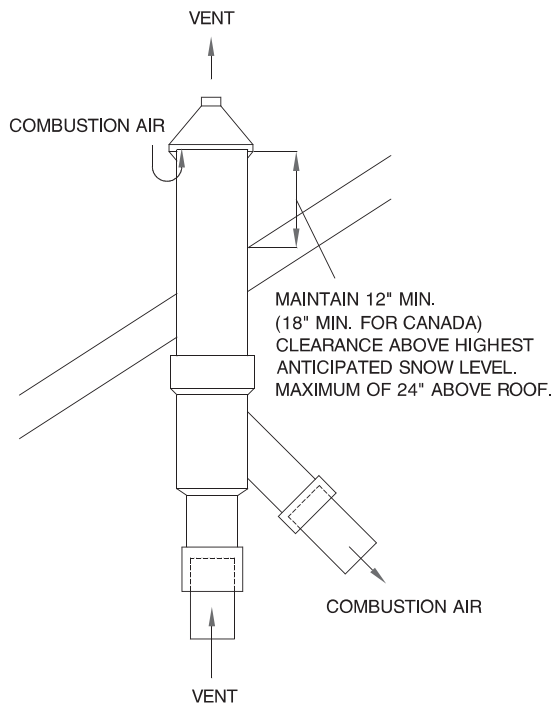

# Venting: Outdoor Installation

## Contaminated Combustible Air Will Damage the Unit

- ❑ Follow all local codes, or in the absence of local codes, follow the most recent edition of The National Fuel Gas Code: ANSI Z223.1/NFPA 54 in the USA or CAN/CSA B149.1 Natural Gas, Propane Installation Code in Canada.
- ❑ Outdoor installation only for a mild climate.

## Outdoor Venting

- ❑ For Outdoor Venting, Intake air pipe should not be next to Exhaust pipe. That will prevent exhaust flue gas from entering the intake air pipe. Make sure there are plenty of air around the intake air pipe and protect any objects from entering the intake air pipe.

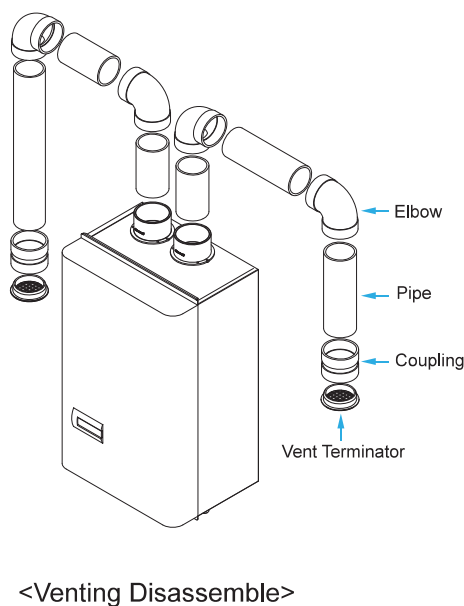
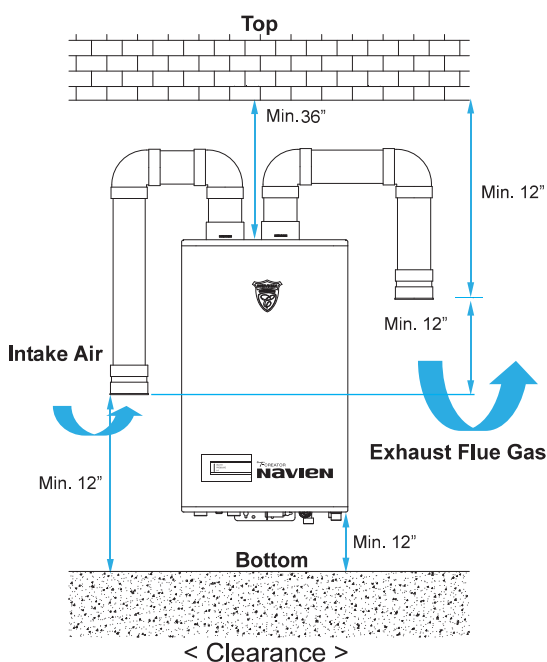

## Venting Clearance

- ❑ When Navien Combination Water Heater / Boiler is installed outdoor, Water Heater / Heating Boiler installed location should be in open unroofed area with following clearance table below.

Bottom of Heater / boiler	Min. 12"
Back of Heater / boiler	Min. 0.5"
Side of Heater / boiler	Min. 3"
Front of Heater / boiler	Min. 24"
Top of Heater / boiler	Min. 36"

**WARNING**

Read all safety warnings in the “User’s Operation Manual”. The additional safety issues outlined below must also be followed completely when installing this Navien Combination Water Heater / Heating Boiler:

**WARNING**

Follow all local codes and/or the most recent edition of the National Fuel Gas Code (ANSI Z223.1/NFPA 54) in the USA or the Natural Gas and Propane Installation Code in Canada (CAN/CSA B149.1).

- Vent terminal should not be pointing toward any opening of the building or windows. Do not install the Water Heater / Heating Boiler in crevices to prevent gas from accumulating.
- Prevent debris, liquid or flammable gas from entering the Combination Water Heater / Heating Boiler intake air pipe terminal. It may cause damage to the Combination Water Heater / Heating Boiler and warranty will be avoided.
- Install the Combination Water Heater / Heating Boiler outdoor under the overhang with 3 feet or more from the eaves to the top of the Combination Water Heater / Heating Boiler vent terminal. Water Heater / Heating Boiler must have open space around all 3 sides.
- Water Heater / Heating Boiler vent terminal should be 4ft(united state)/ 3ft(Canada) or more from windows and doors.



# Pressure Reducing Valve

**CAUTION**

Please do not deliberately remove the O-Ring installed the body of the Water Pressure Reducing valve. Please refer to the graph and change the Water Pressure Reducing valve based on installation circumstance.

## 1. Included Accessories

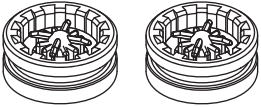
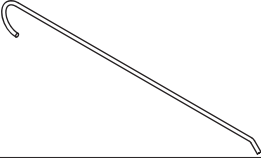
No.	Part	Figure	Q'ty
1	Water Pressure Reducing Valve		2
2	Release Kit		1
3	Installation Manual	-	1

## 2. Characteristic curve of the Pressure Reducing Valve

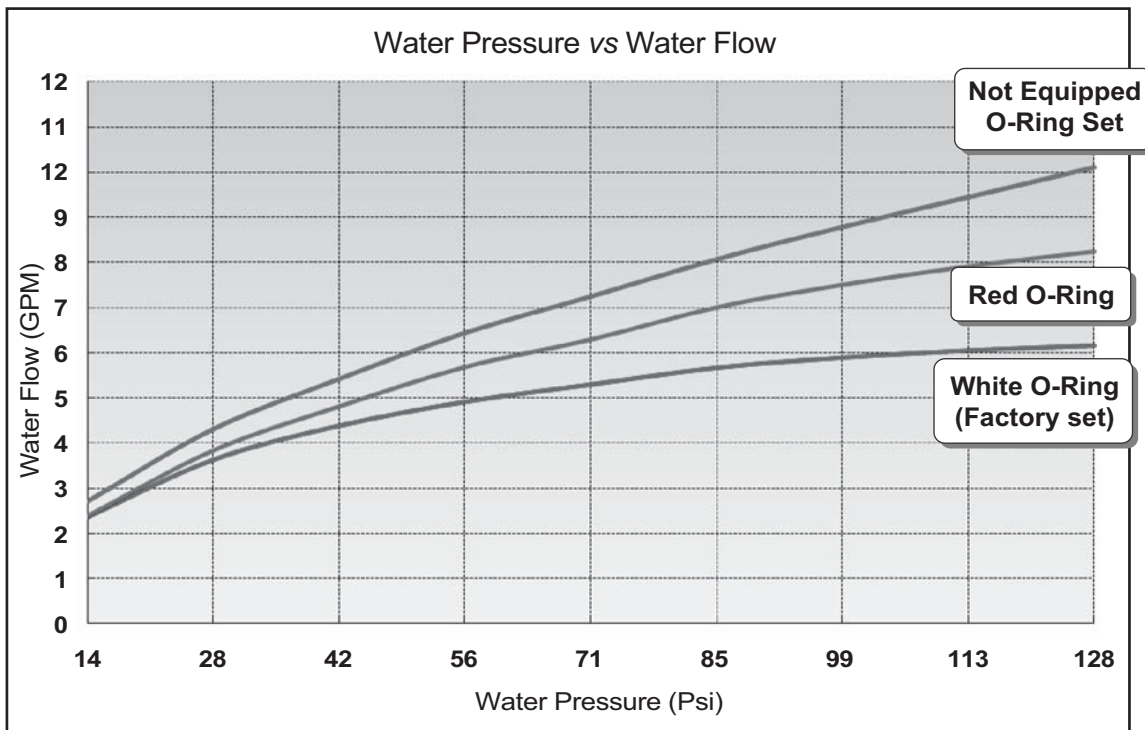

See graph above for the water flow(GPM) and water pressure(psi) to install the pressure reducing valve.

# Pressure Reducing Valve

## 3. Installation Example

The reducing valve's water flow is 4.9 GPM with inlet water pressure is 56 PSI, at the time of factory shipping. If more water flow, 5.7 GPM is needed with inlet water pressure is 56 PSI, please change the reducing valve installed Red O-Ring among the enclosed reducing valve. If more water flow, 6.4 GPM is needed with inlet water pressure is 56 PSI, include the O-Ring among the enclosed reducing valve.

## 4. Replace the Pressure Reducing Valve procedure

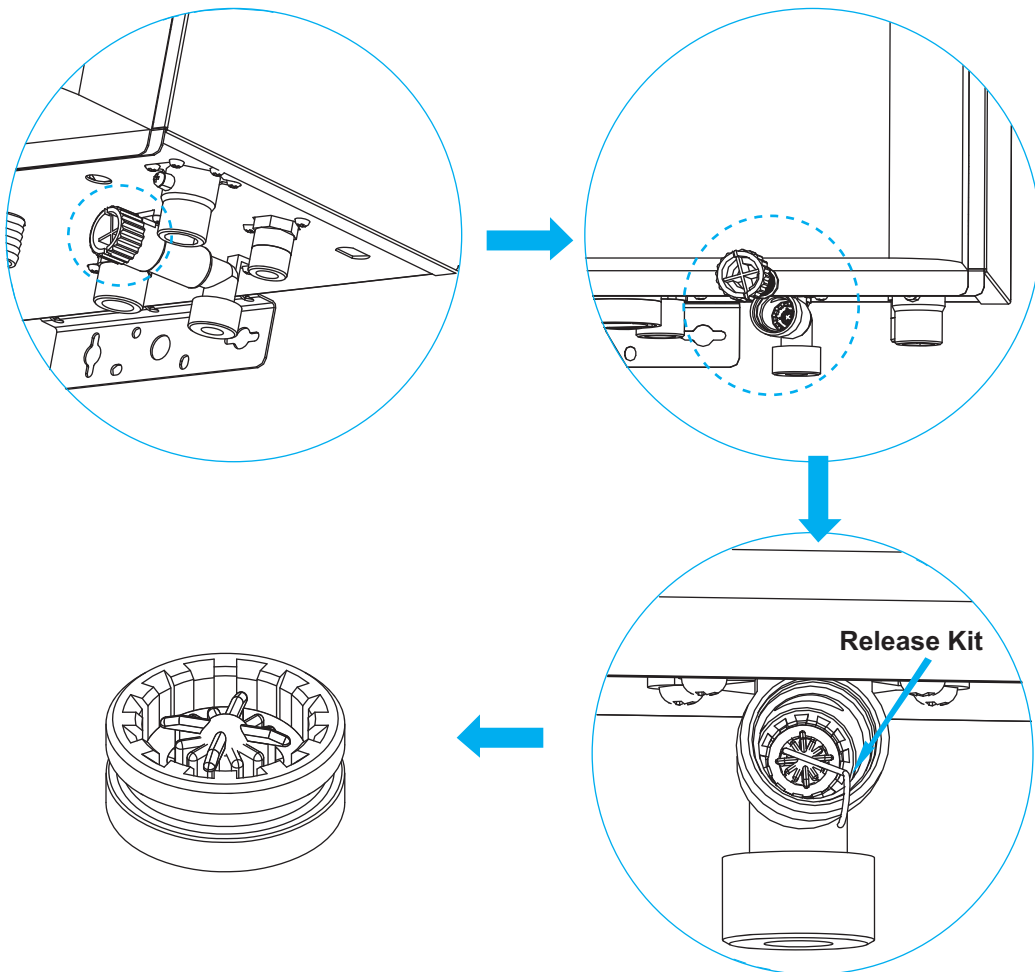

- ❑ Find water inlet adapter located on the bottom of the unit.
- ❑ Release inserted water inlet filter from water inlet adapter turning counterclockwise.
- ❑ Check the ass'y of water pressure reducing valve inside of water inlet adapter.
- ❑ Pull the ass'y of water pressure reducing valve out from water inlet adapter with supplied release kit.

## Outdoor Temperature Sensor (Optional):

### Outdoor Temperature Sensor Installation

- Pull the terminal block out
- Attach the body to the wall with screws/anchors provided
- Run wire into the body through grommet opening
- Connect wires to the terminal block
- Reinstall the terminal block into the Attach the cap to the body
- Attach the cap to the body

### Outdoor Temperature Sensor Installation Guidelines

- Avoid areas with temperature fluctuations caused by direct sunlight, and not representative of true outdoor temperature.
- Best location is on North or Northeast side of structure under eave or shielded from direct sunlight.
- Avoid placing sensor in close proximity of heat sources that may affect correct temperature sensing. (fans, exhausts, vents, lights)
- Avoid placing sensor in area subjected to excessive moisture.
- Use 18 gauge wiring (thermostat wiring) with no splices. (except at unit harness connection with yellow leader wire)
- Caution should be taken to avoid potential electromagnetic interference (EMI) by routing separately from potential sources such as line voltage wiring. When necessary, shielded cable may be used.
- Make sure wiring connections are secure before closing the cap.
- References for the data and temperature of sensor are on the back of this page.
- The unit is a water resistant device, but any damage to the device may require replacing the entire component.

# Outdoor Temperature Sensor (Optional):

## K-Factor (Supply Temperature Setting)

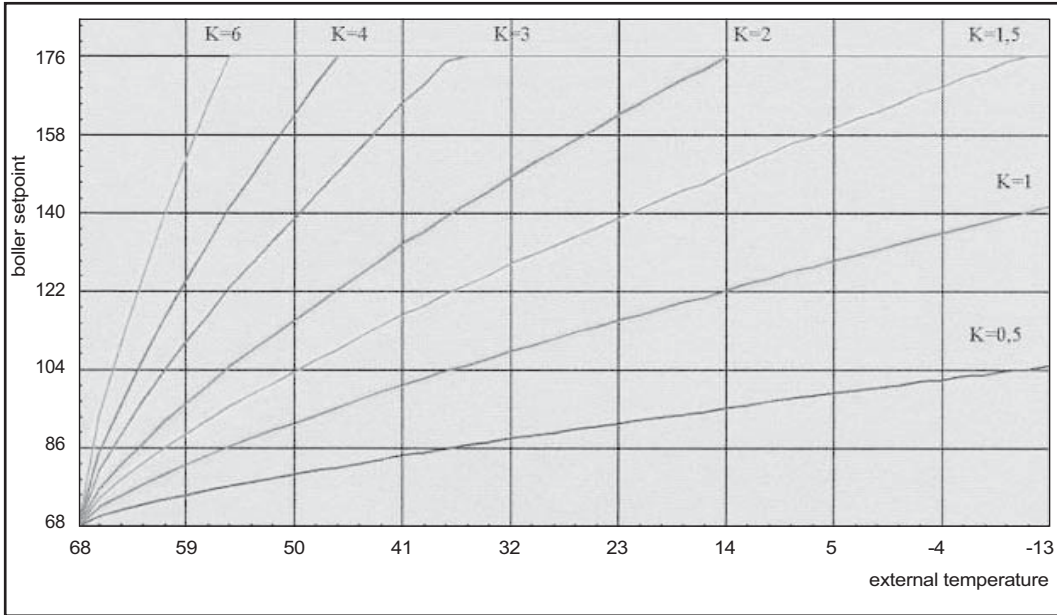

## K-Factor (Return Temperature Setting)

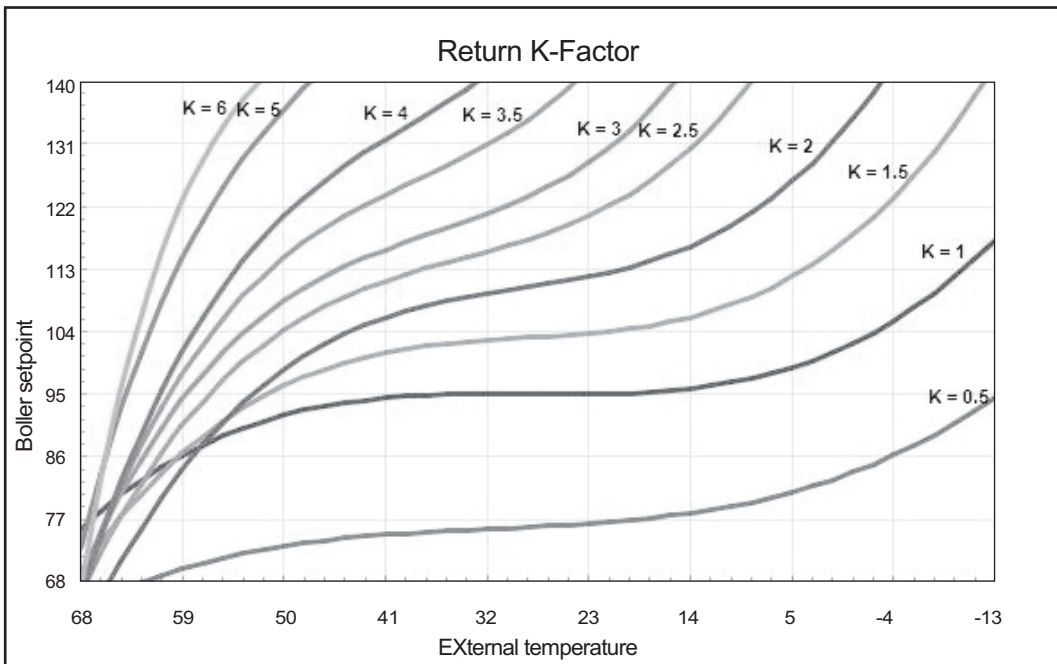

[ Dip Switch #4 of 8 on ]

## Electrical Connections:



### WARNING

Follow the electrical code requirements of the local authority having jurisdiction. In the absence of such requirements, follow the latest edition of the National Electrical Code (NFPA 70) in the U.S. or the latest edition of CGA C22.1 Canadian Electrical Code - Part 1 in Canada.

### Electric Wiring: Grounding and Surges

- All units come with a factory installed 3-pronged (grounded) plug end. The combination Water Heater / Heating Boiler can be plugged into any electrical outlet close to the unit as it requires only 2 Amperes. It is not necessary to run a dedicated electrical line to the combination Water Heater / Heating Boiler.
- If the local jurisdiction requires the unit to be wired directly, remove and discard the factory installed plug. An ON/OFF switch controlling the main power between the breaker and the Navien Water Heater / Heating Boiler should be provided to facilitate end-user maintenance and servicing.
- The combination Water Heater / Heating Boiler must be electrically grounded. Ensure the electrical receptacle, in which the Water Heater / Heating Boiler will be plugged into, is properly grounded; if wiring directly, does not attach the ground wire to either the gas or the water piping as plastic pipe or dielectric unions may isolate the Water Heater / Heating Boiler electrically.
- The use of a surge protector is recommended to protect from power surges.
- Do not plug electrical power to the unit until all plumbing and gas piping is complete and the combination Water Heater / Heating Boiler has been filled with water.**
- The electrical supply required by the Water Heater / Heating Boiler is 110~120VAC at 60Hz with a maximum 2A rating with proper grounding.
- Do not connect 220~240VAC to this Navien Combination Water Heater / Heating Boiler. It will damage the combination Water Heater / Heating Boiler and this damage is not covered under warranty**
- Do not disconnect the power supply when the unit is in normal operation.
- If there is a power failure in cold weather areas, the freeze prevention system in the Water Heater / Heating Boiler will not operate and may result in freezing of the heat exchanger; in cold weather areas where power failures are common, you must completely drain the unit to prevent damage if the power will be off for any extended period of time.
- A battery back-up (available at most computer retailers) may be used to supply hot water during periods of power outages.
- Damage caused by freezing is not covered under warranty.



### CAUTION

**Label all wires prior to disconnection when servicing controls. Wiring errors can cause improper and dangerous operation. Verify proper operation after servicing.**

# Remote Controller Installation:

Remote Controller NR-10PU

The following are considerations for determining the location of the remote controller:

- Disconnect the power to the combination Water Heater / Heating Boiler before installing the remote controller.
- The wire on the reserve of a remote controller is connected to the orange wire on the PCB board which is located on bottom of the combination Water Heater / Heating Boiler. The naked wire must be completely insulated after connection. **DO NOT** connect 110~120VAC to this remote controller.
- The maximum length of wire between the combination Water Heater / Heating Boiler and the remote controller installation location is limited to a maximum of 300 feet.
- There is no polarity.
- The remote controller is water resistant but not water proof.
- Do not install the remote controller outdoors.
- Do not install the remote controller in any area where the controller will be directly exposed to water, heat, humidity or steam.
- Place remote controller out of children's reach.
- Do not disassemble the remote controller.
- Feed the remote controller wire through the black rubber seal at the bottom, right hand, back corner of the case.

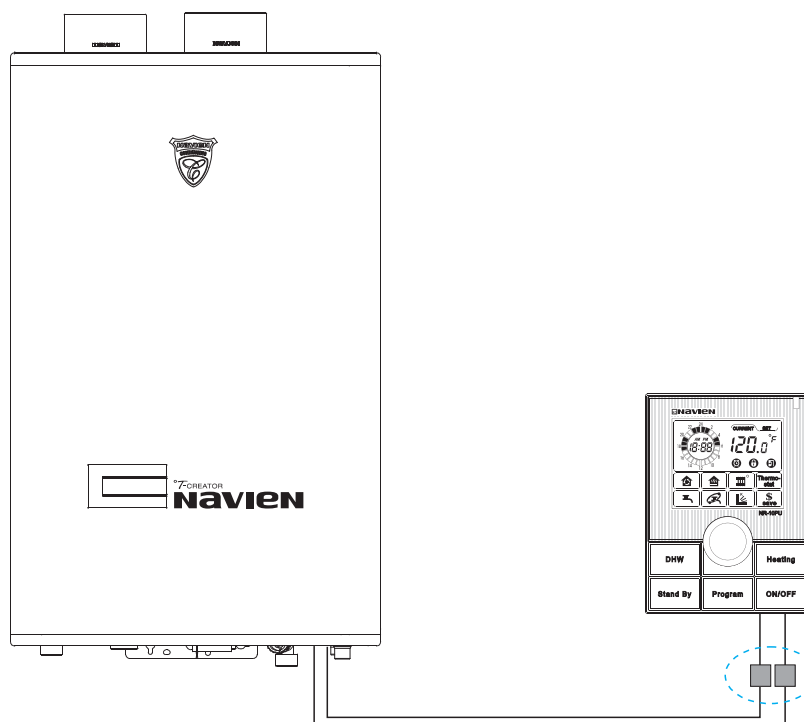

# PCB Board Settings:

## Combination Water Heater / Heating Boiler Temperature Settings:



### WARNING

Hot water temperatures over 125°F can cause severe burns instantly or death from scalding.

- ❑ With the Navien Combination Water Heater / Heating Boilers, the temperature has been preset at the factory to 120°F (49°C) (Only DHW mode). The PCB board will electronically control this temperature. The output hot water temperature can be adjusted either manually using the PCB board's DIP switches or with the remote controller. Using the dipswitches, 4 hot water output temperature can be selected. Please refer to the chart below.
- ❑ Once the remote controller is connected to the combination Water Heater / Heating Boiler, it overrides the PCB board dipswitch settings. If the remote controller is disconnected from the unit, the PCB board will automatically revert to the temperature indicated by the dipswitches. The PCB board does not store the remote controller's temperature in memory. As such, the remote controller must remain connected to the Water Heater / Heating Boiler at all times to maintain any temperature other than the 4 presets.

### SUPPLY TEMPERATURE SETTING

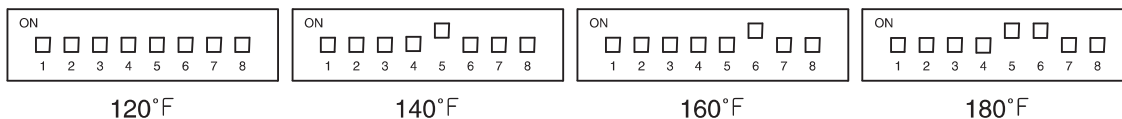

**Warning: Only change relevant switches. DO NOT touch any other switches.**

### RETURN TEMPERATURE SETTING

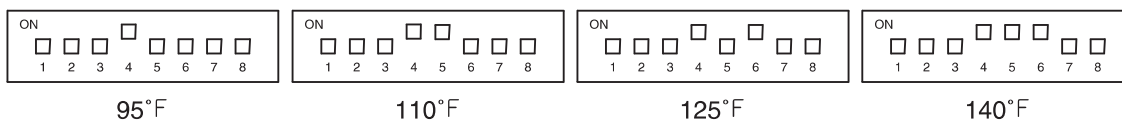

**Warning: Only change relevant switches. DO NOT touch any other switches.**



### NOTICE

The Factory default setting temperature 125°F (51°C) for Return control mode.

# Cascade Connection and Set-up Procedures:



## CAUTION

This drawing can be a useful guideline when installing a unit. However, installation may vary depending on the location circumstances, local building codes or state regulation. Make sure to check the local building codes and state regulation before installation, and comply with it.

### 1. Step 1: Plumbing

Only 1 Combination Water Heater / Heating Boiler can be installed in a cascade system and it must be the master. The slave units can only be Navien NR-(A) or NP-(A) Water Heater / Heating Boilers. The maximum number of units per cascade is 16, supplying as much hot water as needed. (In case of cascade setting with CR/CC model, additional download is needed. In case of cascade setting with NP model, the maximum hot water temperature is limited to 140°F)

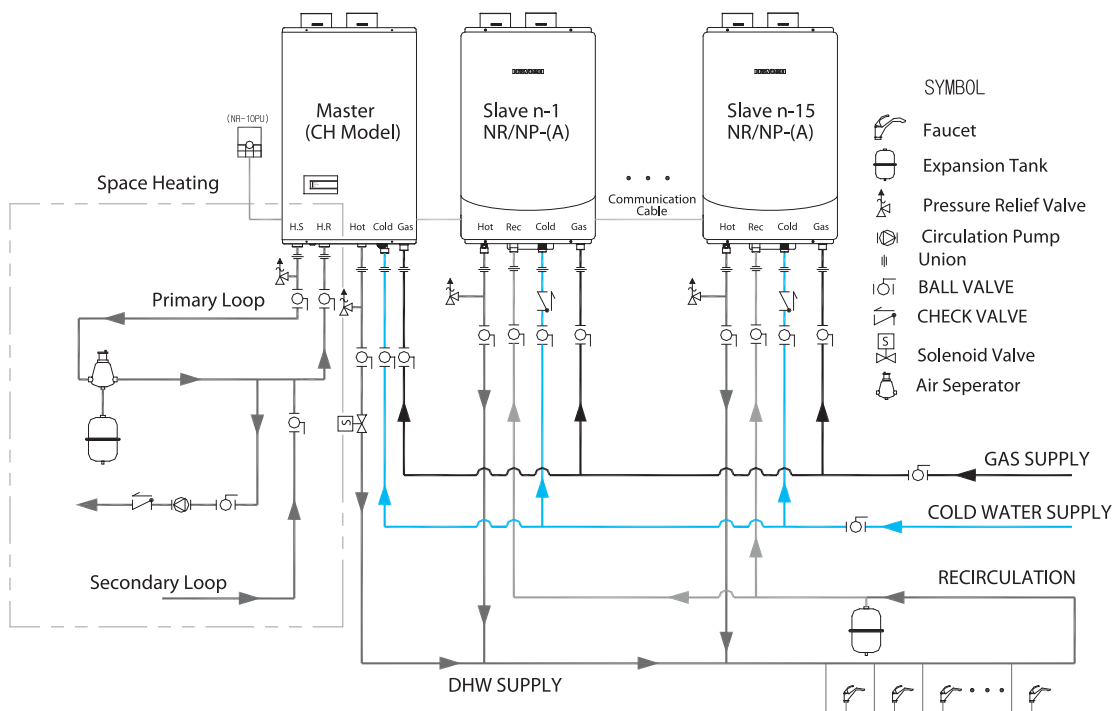

- Install check valve in the “A” series cold water inlet for cascade system.
- When linking with CH series connect the solenoid valve wire to the external power wire of CH series.

The trunk line should be sized properly to fit individual applications.

During step 1, the power supply should be OFF.

In case of installing solenoid valves to CH model pipes (supply hot water); the connection should be made to PCB board external power port. (refer to wiring diagram)



## 2. Step 2: Cable connection and DIP switch change

A multiple unit, which is composed of 1 combination Water Heater / Heating Boiler and up to 15 Water Heater can be connected by using Naviens' Multi-Link communication cables inside.

The combination Water Heater / Heating Boiler shall be set as a master unit, which can be done by switching the 1st switch of DIP SW2 on. All Water Heater / Heating Boilers shall be set as slave units, which also can be done by switching the 1st switch of DIP SW2 off. (as shown in the figure below)

During step 2, the power supply should be OFF.

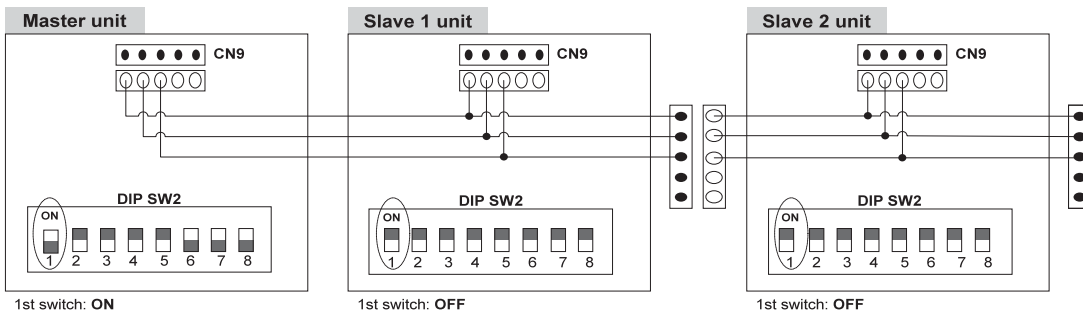

Cable connection and DIP switch set-up

-cascade communication cable PCB connecting adapter PCB CN9 port.

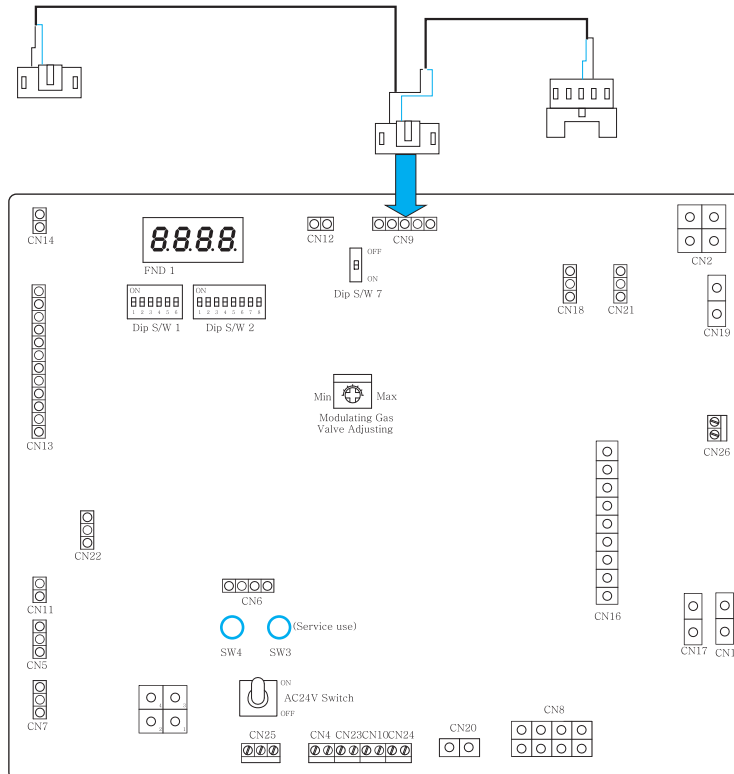

- The diagram above displays the master unit and slave unit connected with the ready link communication cable.

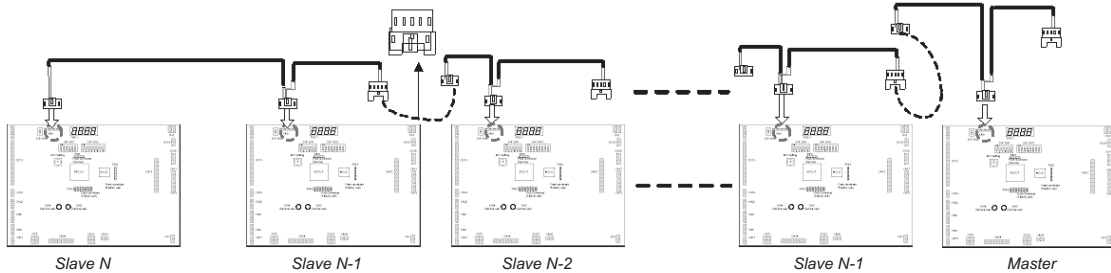

- The recommended location for the master unit is in the center.
- The Dip SW7, which is used only for organizing cascade system. Be switches ON if the corresponding unit is the first or the last unit of Cascade connection.

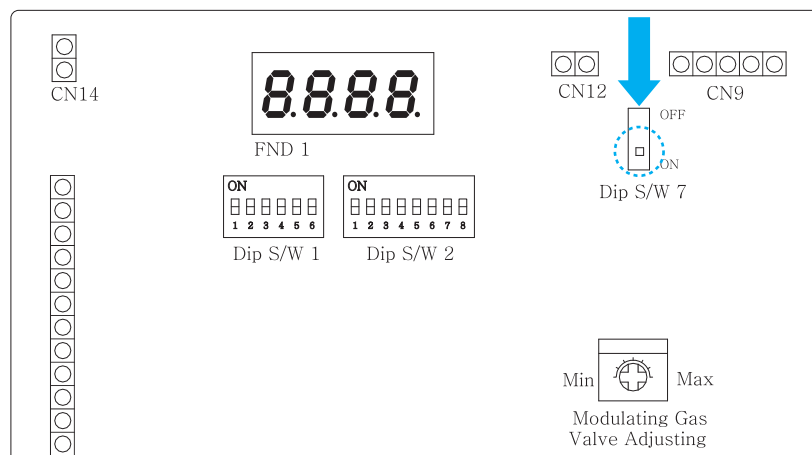

### 3. Step 3: Communication set-up

After the cable connections and DIP switches are set-up, the communication set-up should be done.

#### 3.1 Master set-up

After the power ON, each FND1 will display on the PCB as below:

Unit	Master Unit	Slave 1 Unit	Slave 2 Unit
FND1	4.0.0.1	5.0.0.0	5.0.0.0

FND1 display: Master set-up

#### 3.2 Slave set-up

After the master set-up, push and hold the Tack SW3 and Tack SW4 of slave 1 unit simultaneously for 3 seconds.

FND1 of the slave 1 unit will read “S001”.  
 Slave 2 unit also can be set-up as above.  
 After the slave set-up, each FND1 will read as below:

Unit	Master Unit	Slave 1 Unit	Slave 2 Unit
FND1	H.0.0.1.	5.0.0.1.	5.0.0.2.

FND1 display : Slave set-up

### 3.3 Set-up finish

After the slave set-up, push and hold the Tack SW3 and Tack SW4 of the master unit simultaneously for 3 seconds.  
 All the FNDs will display the setting temperature and set-up procedures are finished.

### 4. Master unit Change

Because a multiple unit shall use only 1 combination Water Heater / Heating Boiler and the combination Water Heater / Heating Boiler shall be a master unit, it is impossible to change the master unit.

### 5. Slave unit Addition/Removal

It is always possible to add or remove the slave unit. After all unit power OFF, the communication cable is added or removed on the PCB according to slave unit addition or removal.

There are two cases for system set-up;

Master unit unchanged: In this case, it is necessary to change the processing mechanism of the master unit. The set-up procedures are as below: (5.1 – 5.3)

#### 5.1 Master unit set-up

To add or remove the slave unit, DIP SW1 and SW2 of the master unit PCB are changed as below:

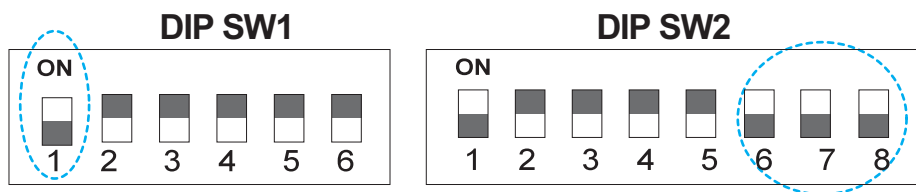

DIP Switch set-up of the master unit PCB: Slave unit addition/removal

#1 switch (DIP SW1) and #6-8 switches (DIP SW2) should be set to ON position.  
 After all unit power ON, push and hold the Tack SW3 and Tack SW4 of the master unit simultaneously for 3 seconds.

Each FND1 will display on the PCB as below:

Unit	Master Unit	Slave 1 Unit	Slave 2 Unit	Slave 3 Unit
FND1	H.0.0.1.	5.0.0.0.	5.0.0.0.	5.0.0.0.

FND1 display: Master set-up (slave unit addition)

### 5.2 Slave unit set-up

This procedure is same as the **3.2 Slave set-up** of **Step 3: Communication set-up**.

After the slave set-up, each FND1 will display on the PCB as below:

Unit	Master Unit	Slave 1 Unit	Slave 2 Unit	Slave 3 Unit
FND1	40.0.1	50.0.1	50.0.2	50.0.3

### 5.3 Set-up finish

After the slave set-up, DIP SW1 and DIP SW2 should be set to the original position and push and hold the Tack SW3 and Tack SW4 of the master unit simultaneously for 3 seconds. All the FND's will display the setting temperature and set-up procedures are finished.

## 6. Error display

In case of the error condition in the cascade system, a relevant error and unit are displayed on the remote controller.

If a master unit is in DHW operation mode, instead of slave error code, the hot water temperature of the master unit is displayed.

Error display example:

- 1) Error code 35 of the master unit

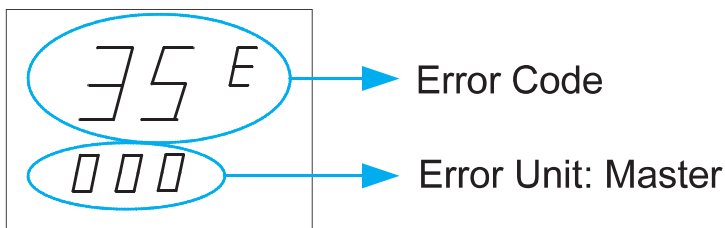

- 2) Error code 35 of the slave 1 unit

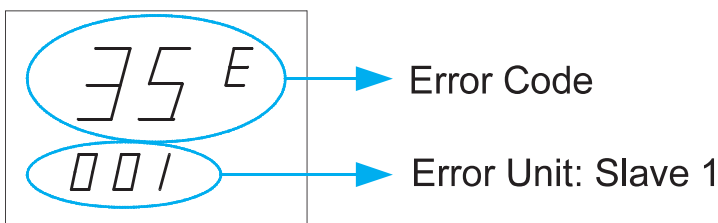

# Combination Water Heater / Heating Boiler DIP Switch Settings:

There are two sets of DIP switches; one set has 6 switches and the other has 8 switches.

## Set of Dip Switch #1. (6 Switches):

DIP S/W No.	Description		
	Function	ON	OFF
1	Operation Select 1	(1) Operation Mode Select	
2	Operation Select 2		
3	Gas Type Select	Liquid Propane	NG
4	Vent Select	Individual Vent	Common Vent
5	Model Select 1	Factory Setting	
6	Model Select 2		

## #1 & 2: Burner Operation Mode Select

Operation Mode	DIP Switch	
	1	2
Normal Operation	OFF	OFF
Maximum Operation	ON	OFF
Minimum Operation	OFF	ON
3 Stage Minimum	ON	ON

This dip switch set up is only for Factory use.

### #5 & 6: Model Selection

Model	DIP S/W	
	5	6
CH-180	OFF	OFF
CH-210	ON	OFF
CH-240	OFF	ON

### Set of 8 Switches: Operation Mode Selection

DIP S/W No.	Description		
	Function	ON	OFF
1	Ready-Link Multi-System Select	Ready-Link Multi-System Master	Normal System
2	Hot Water Pre-heating Function	Using Remote Controller	Depends on the timer setting of Remote Controller
		Non-Using Remote Controller	Using Hot Water Pre-heating Function      Non-Using Hot Water Pre-heating Function
3	External Thermostat Select	Using Remote Controller	Using External Thermostat      Non-Using External Thermostat
		Non-Using Remote Controller	Always Using External Thermostat
4	Space Heating Temperature Control	Return Temperature Control	Supply Temperature Control
5	Space Heating Temperature 1	Refer to next page (#5 & 6)	
6	Space Heating Temperature 2		
7	DHW Temperature 1	Refer to next page (#7 & 8)	
8	DHW Temperature 2		

### #4 & 5& 6 (Space Heating Used Only):

Supply / Return Temperature Selection

Temperature	DIP Switch		
	4	5	6
120°F (49°C)	OFF (Supply)	OFF	OFF
140°F (60°C)		ON	OFF
160°F (71°C)		OFF	ON
180°F (82°C)		ON	ON
95°F (35°C)	ON (Return)	OFF	OFF
110°F (43°C)		ON	OFF
125°F (51°C)		OFF	ON
140°F (60°C)		ON	ON

### #7 & 8 (DHW Used Only):

Hot Water Temperature Selection

Temperature	DIP Switch	
	7	8
110°F (43°C)	OFF	OFF
120°F (49°C)	ON	OFF
130°F (54°C)	OFF	ON
140°F (60°C)	ON	ON

#### Dip Switch 7:

The dip switch 7, which is used only for organizing cascade system, be switched ON if the corresponding unit is the first or the last unit of cascade connection.

## Installation Checklist:

### **Selecting the location and installing the combination Water Heater / Heating Boiler:**

- Are the proper clearances from windows, doors and other intake vents maintained?
- Is the distance between the combination Water Heater / Heating Boiler and point of vent termination minimized?
- Is distance between combination Water Heater / Heating Boiler and major fixtures within the house minimized?
- Are the proper service clearances maintained?
- Is the make-up air supply sufficient for proper operation of the combination Water Heater / Heating Boiler?
- Is the make-up air supply free of dust, dirt, corrosive elements and flammable vapors?
- Is there a drain in close proximity of the combination Water Heater / Heating Boiler?
- Are all combustible materials including clothing, cleaning materials, rags, etc. clear of the combination Water Heater / Heating Boiler and vent piping?
- Is the combination Water Heater / Heating Boiler securely mounted to the wall?

### **Water Supply**

- Is the water supply pressure sufficient (should be greater than 40psi)?
- Are there shut-off valves on the inlet and outlet to facilitate cold water inlet filter cleaning?
- Has the air been bled out of each fixture?
- Has each fixtures been checked to ensure hot water is being supplied?
- Has the cold inlet water filter been cleaned?
- If a recirculation line has been installed, have all of the hot water pipes and the recirculation return lines been insulated?



### Pressure Relief Valve

- Is there an approved pressure relief valve installed on the hot water outlet and space heating outlet?
- Does the rating plate on the pressure relief valve indicate a BTU level equal to the maximum BTU rating of the combination Water Heater / Heating Boiler?
- Is the pressure relief valve 3/4" on the hot water outlet?
- Is the pressure relief valve 1" on the space heating outlet?
- Has the pressure relief valve been installed on the hot outlet pipe and space heating outlet close to the exit of the combination Water Heater / Heating Boiler?
- Has a discharge drain tube been installed from the pressure relief valve to within 6~8" of the floor?

### Gas Supply

- Does the gas supply match the combination Water Heater / Heating Boiler's gas type indicated on the rating plate?
- Is the gas line a minimum of 3/4" ID (inner diameter)?
- Is the gas supply line length and diameter sufficient to deliver the required BTUs?
- Has the gas supply line pressure been measured?
- Is the gas supply pressure sufficient for proper operation (within the ranges indicated in the specifications section of this manual)?
- Is the gas line equipped with a manual shut-off valve?
- Has the gas line been pressure tested and/or have all fittings been checked for leaks?
- Has the gas company inspected the installation (if required)?

### Venting

- Has the combination Water Heater / Heating Boiler been vented with 3" ABS (except cellular core ABS), 3" PVC, Navien's 4" Stainless Steel Concentric Vent kit or Type BH Special Gas Vent (S636 PVC or stainless steel) for Category IV appliances or in accordance with this manual and/or your local code?
- Ensure that ABS cellular core or PVC cellular core pipe has not been used as venting for this Water Heater / Heating Boiler.
- Is the vent sloped upwards toward the vent terminal at a rate of 1/4" per foot (2% grade)?
- Are all vent runs properly supported?
- Has the vent terminal been properly supported?
- Have all air intake and exhaust joints from flue collar to termination been properly sealed?
- Have the vent end caps been installed on the exhaust and the intake pipes?
- Has the venting been checked for leakage?
- Is the vent terminal a minimum of 12" above the exterior grade?
- Has sufficient make-up air been supplied?
- Is the total vent length within the stated maximum vent length restriction?
- Has a condensation drain line been installed from the combination Water Heater / Heating Boiler to a floor drain or laundry tub?

### Electrical Wiring

- Is the supplied voltage 110~120VAC?
- Is the combination Water Heater / Heating Boiler plugged into a properly grounded electrical outlet?
- If the supplied power cord has been discarded to meet local codes, has an "ON/OFF" switch been installed to facilitate end-user maintenance?

### ❑ **DIP Switch Settings:**

#### **For the set of 6 DIP switches:**

- Are switch #1 and #2 in the down (OFF) position?
- Is switch #3 properly set for the gas supply type?
- Is switch #4 properly set for the cascade vent type? (Individual vent or common vent)
- Are switch #5 and #6 set for the proper model number?

#### **For the set of 8 DIP switches:**

- Unless using quick link multi-system, is switch #1 in the down (OFF) position?
- When the Remote Controller is used, is switch #2 in the down (OFF) position?
- Is switch #2 in the down (OFF) position?
- Unless using Thermostat, is switch #3 in the down (OFF) position?
- Is switch #4 properly set for the Supply control or Return control mode?
- Are switches #5 and #6 set to the customer's desired CH temperature?
- Are switches #7 and #8 set to the customer's desired DHW temperature? Recommended temperature should not exceed 140°F.

### ❑ **Final**

- Has the owner been advised of the minimum flow rate to trigger the burner?
- Has the owner been shown how to clean the cold water inlet filter?
- Has the owner been left with the operation and installation manual for future reference?
- Has the owner been shown how to shut off the gas in case of an emergency?

# Maintenance

## Annual Maintenance and Inspection

### IMPORTANT

This unit requires very little maintenance, however a qualified technical should inspect it at the beginning of every heating season and/or when have a problem Unit.

**Make sure:**

- The condensate freely flows from the unit, and is cleaned of sediment.
- Air Vent and/or Relief valves are not weeping.

- Low water cut off is flushed. (as applicable)
- Examine all venting, for evidence of leaks, and vent screens are cleaned.

- Peridoic examination of venting systems. Ensure that no debris is in the entrance of inlet air pipe and no debris at the exhaust pipe.

- Use a large bottle brush for cleaning flue gas passgeways.
- Peridoic cleaning of the condensate collection and disposal system(s). (as applicable) Every 6 months, pull off condensate hose and ensure no debris is in the hose.
- If you suspect the burners need cleaning, call a Navien-approved technician. Do not open the burner compartment.
- Peridoic visual check of burner flames through burner window. You should see 1/2"~ 3/4" blue flame.
- Keeping boiler area clear and free from combustable materials, gasoline and other flammable vapors and liquids.
- No obstruction of combustion and ventilati on air. Keep objects and loose materal away from vent inlet/exhausts.
- Ensure PVC venting and fittings are tight. If cracked or loose, replace fittings and apply proper silicone sealing.

## Factory Default Setting of Dip Switch:

### NG

#### CH-180

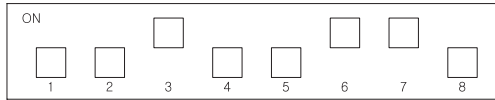
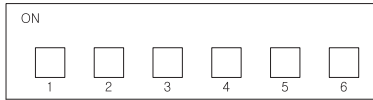

#### CH-210

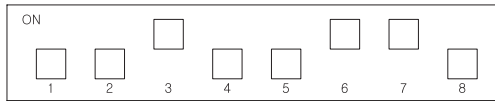
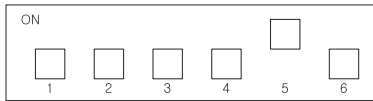

#### CH-240

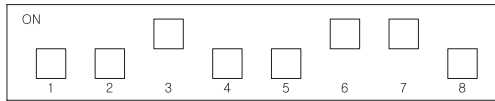
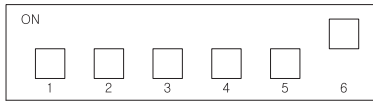

### Propane

#### CH-180

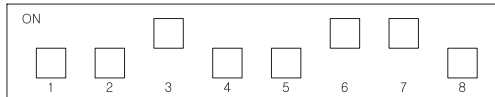
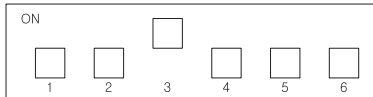

#### CH-210

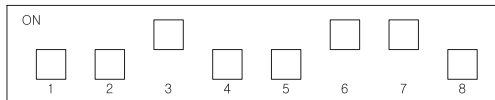
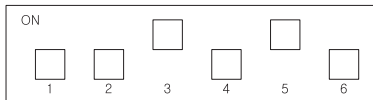

#### CH-240

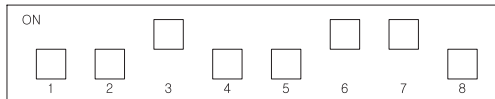
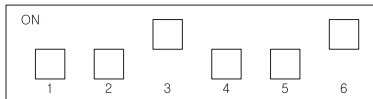

## Completing the Install:

If you answered “yes” to all of the questions in the above checklist, your install is now complete. If you answered “no” to any of the points in the checklist, please review the installation and operation manuals to confirm your installation. For any troubleshooting issue, see the “Error Codes” section of the operating manual. For any questions or problems during the installation, contact Navien’s technical department toll-free at 1-800-519-8794 (949-420-0420) or visit the technical support section of the website at:

[www.navienamerica.com](http://www.navienamerica.com)



# Ladder Diagram:

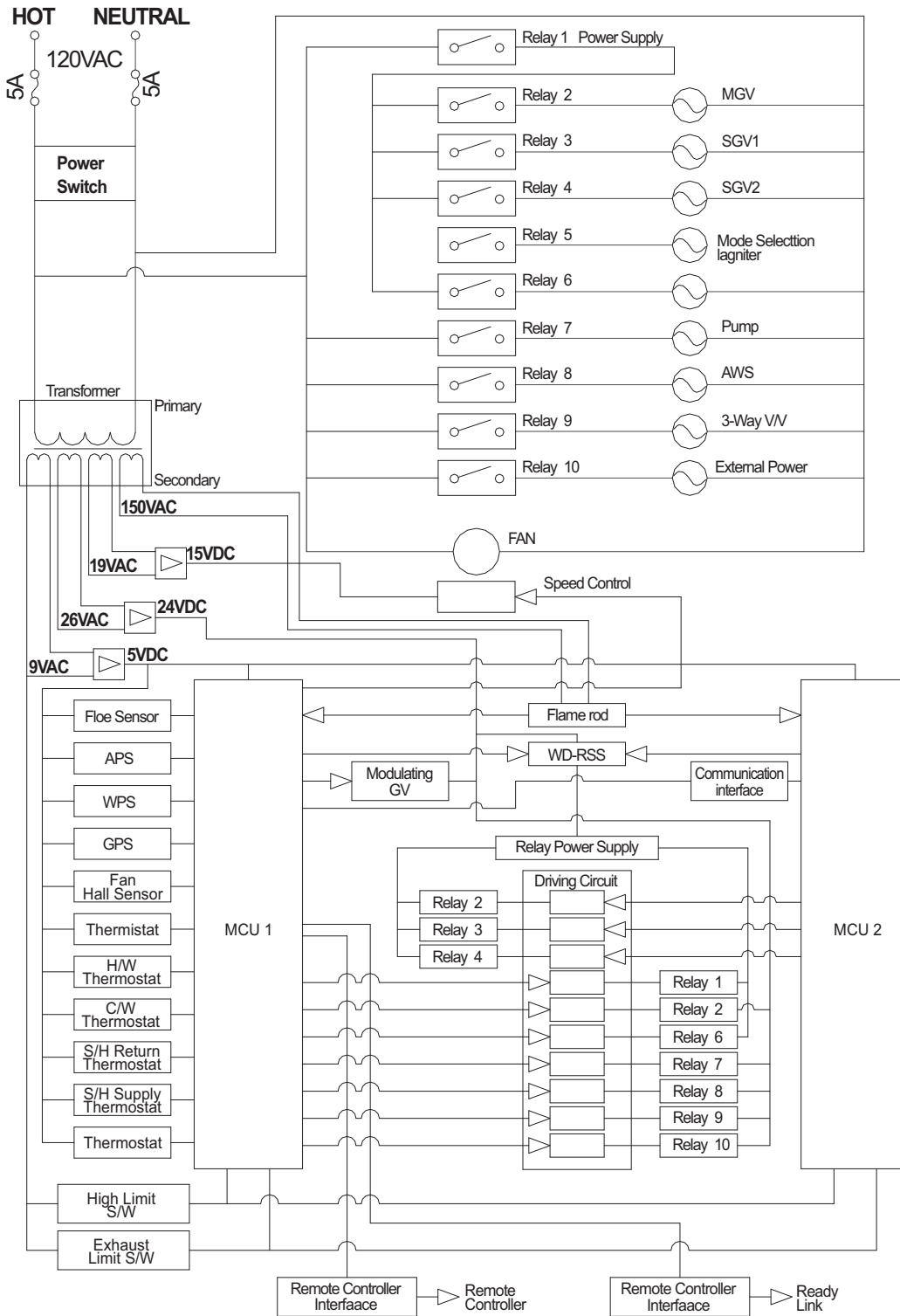

## Wiring:

- ❑ The unit must be in OFF position before connecting the electrical wires.
- ❑ Make sure the circuit breaker on the distribution panel is OFF or ON/OFF switch in the Navien Combination Water Heater / Heating Boiler is OFF.
- ❑ From the bottom of Navien combination combination Water Heater / Heating Boiler, connect the 120 VAC.
- ❑ When Room Thermostat needs external 24 VAC power, Navien Combination Water Heater / Heating Boiler provides 24 VAC power for your convenience or having external 24 VAC transformer.
- ❑ Terminal for connecting Thermostat R and W not required any power.
- ❑ It works as contact point.
- ❑ It is advised that main supply voltage fluctuations are not to exceed 10 percent of the nominal supply voltage.
- ❑ It is specified that a switch or circuit-breaker shall be included in the building installation, it shall be in close proximity to the equipment, and it shall be marked as the disconnecting device for the equipment.
- ❑ It is required to have insulation for external circuits to conform to the requirements for protection against electric shock.
- ❑ It is required to have over current protection devices when installed indoors.



❑ In-Floor Radiant Heating System and Baseboard Heating System

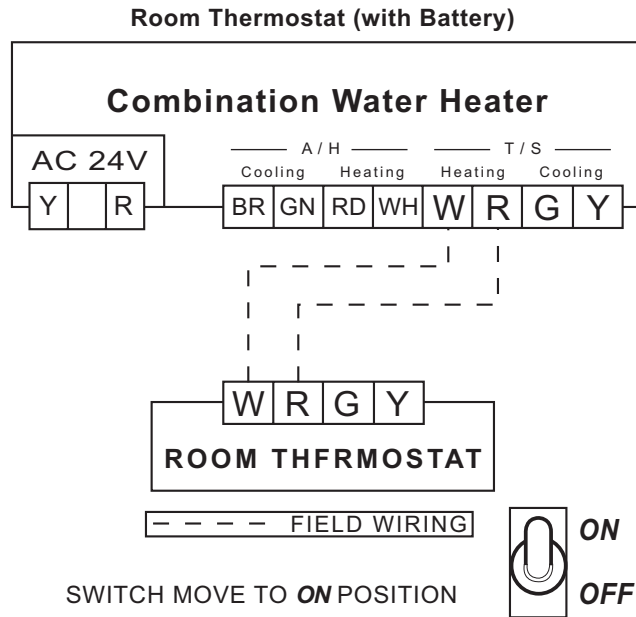

❑ Fan-Assisted Hydro Heating System

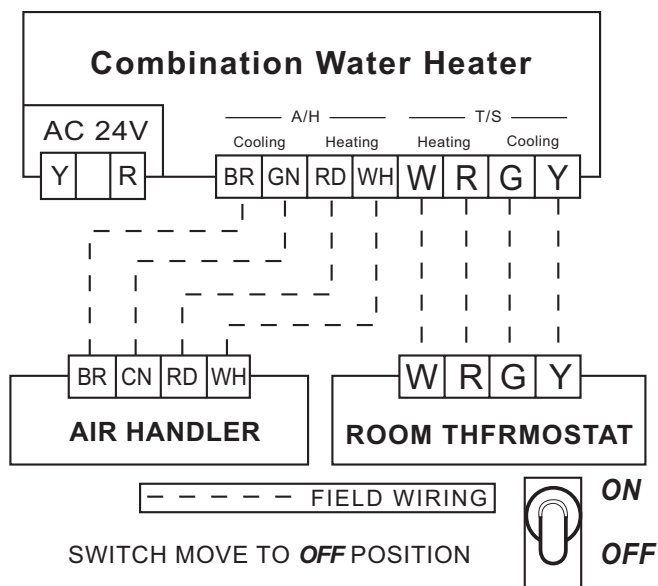

# Components Diagram & Parts List:

## 1.1 Case Disassemble

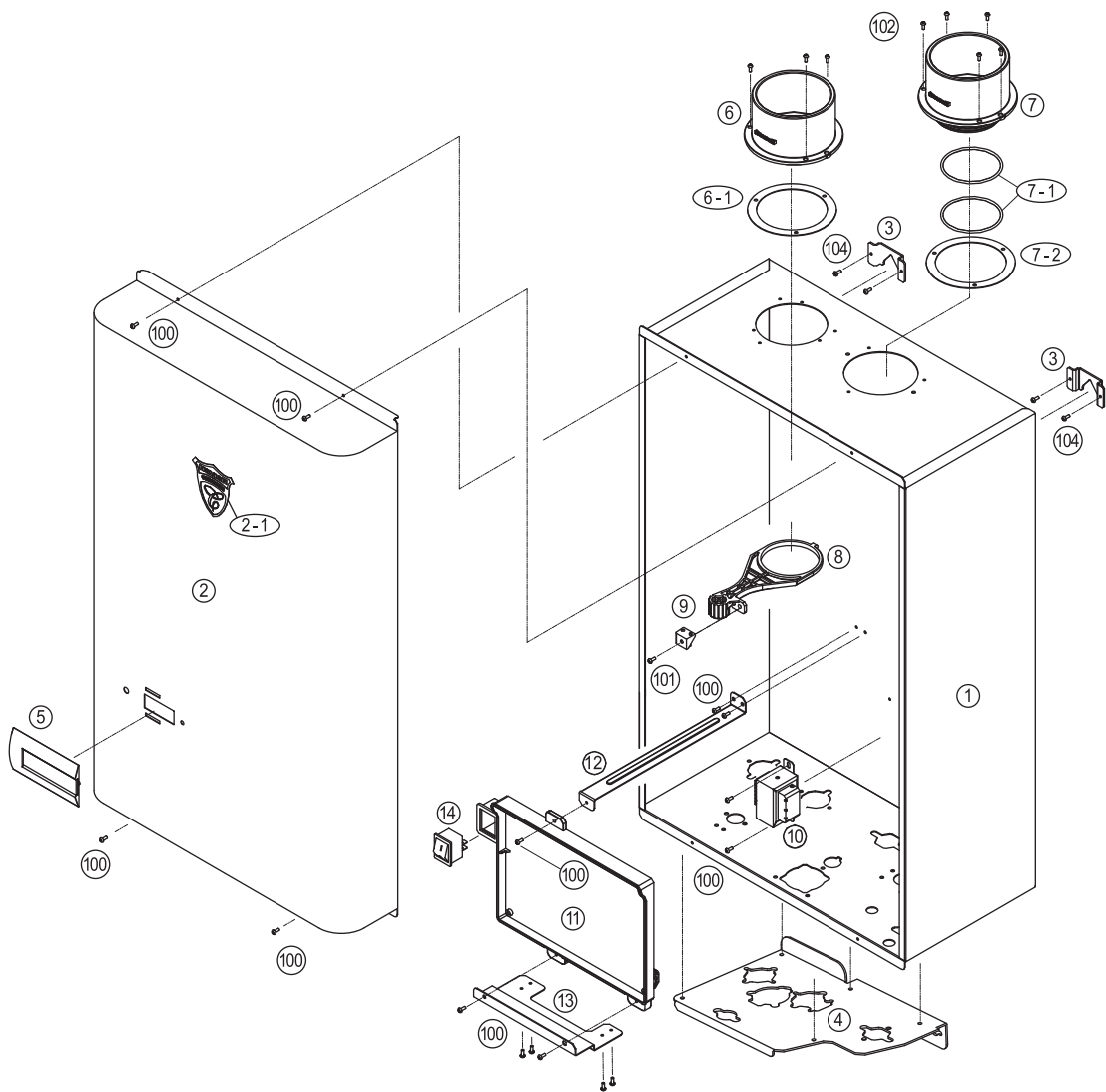

## 1-2. Case Part List

NO	Description	Navien Part No.	Remark
1	Case	BBK05011089	
2	Cover	BBR15012136	
2-1	Emblem	BH2603008A	
3	Case Upper Bracket	BH2505277A	
4	Case Lower Bracket	BBK05197001	
5	Deco	BH2602012A	Pressure Indicator
6	Intake Air Duct Ass'y	BH2505400B	
6-1	Intake Air Duck Packing	-	No.6 Ass'y
7	Exhaust Pipe Ass'y	BH2505401B	
7-1	Exhaust Pipe O-Ring	-	No.7 Ass'y
7-2	Exhaust Pipe Packing	-	No.7 Ass'y
8	Intake Air Filter	BH2505416A	
9	Intake Air Filter Support	BH2505417A	
10	Transformer	BH1205011A	
11	PCB Board	NACR1GS32301	
12	PCB Board Bracket(Upper)	BH2505413A	
13	PCB Board Bracket(Lower)	BH2505414A	
14	Power Switch	BH1426002A	
100	Screw D4 x 8L	BH1705007A	
101	Bolt M4 x 16L	BH1603009A	
102	Screw D4 x 12L	BH1612005A	
104	Bolt D4 x 10L (STS)	BH1611006A	



## 2-2. Burner Part List

NO	Description	Navien Part No.	Remark
17	Fan Motor	NAFA9GSFB002	
18	Flame rod ass'y	PH1603058D	NG
		PH1603059D	Propane
18-1	Flame rod	BH2501679A	NG
		BH2501680A	Propane
18-2	Flame rod packing A	BH2505054A	
18-3	Flame rod packing B	BH2405051A	
18-4	Flame rod bracket	BH2505681A	
20	Air Pressure Sensor	NASS9EX00009	
22	Burner	PABNCN30KDBN_003	180 NG
		PABCR180ABN_002	180 Propane
		PABNCW48KDBN_002	210/240 NG
		PABCR210/240ABN_002	210/240 Propane
24	Burner Bracket (L)	BH2501444C	
26	Manifold	PABCR180AMF_001	180 NG
		PABNR/NP180AMF_001	180 Propane
		PABCC210AMF_001	210/240 NG
		PABCC210AMF_002	210/240 Propane
26-1	Solenoid valve	PH0905028A	
27	APS venturi	BH2501413A	
28	APS venturi packing	BH2405031A	
29	Thermal fuse	BH1419012A	180
		BH1419013A	210/240
30	Ignition transformer	BH1201045A	
31	Fan motor bracket	BH2501604A	210/240
		BH2501605A	180
33	Gas Pipe	BH2546021A	210/240 NG
		BH2546025A	210/240 Propane
		BH2546020A	180 NG
		BH2546024A	180 Propane
34	GPS venturi	BH2507663A	180
		BH2507733A	180 Propane
		BH2507664A	210/240
		BH2507732A	210/240 Propane
34-1	GPS venturi tube	BH2203002A	
39	Gas pressure sensor	NASS9EXGPS01	
40	GPS bracket	BH2507346A	
43	Main gas valve	BH0901018A	
44	Gas inlet adapter	BH2507714A	
79	Tube	BH2202022A	180
		BH2202025A	210/240

NO	Description	Navien Part No.	Remark
80	Tube	BH2202023A	180
		BH2202024A	210/240
82	Tube (550L)	BH2203001A	
83	Tube	BH2202036A	180
		BH2202041A	210/240
86	O-Ring	BH2421008A	
100	Screw D4 x 8L	BH1705007A	
103	Screw D4 x 6L	BH1612004A	
104	Bolt D4 x 10L (STS)	BH1611006A	
105	Screw D4 x 14L	BH1701031A	
107	Screw D4 x 14L	BH1708006A	
111	Bolt M4 x 12L (STS)	BH1603007A	
113	Screw D4 x 25L	BH1701030A	
116	Fan Motor Damper	BH2505403B	
117	O-Ring	BH2421003A	
123	Screw D4 x 4L	BH1710001A	

# Components Diagram & Parts List:

## 3-1. Water Way Disassemble

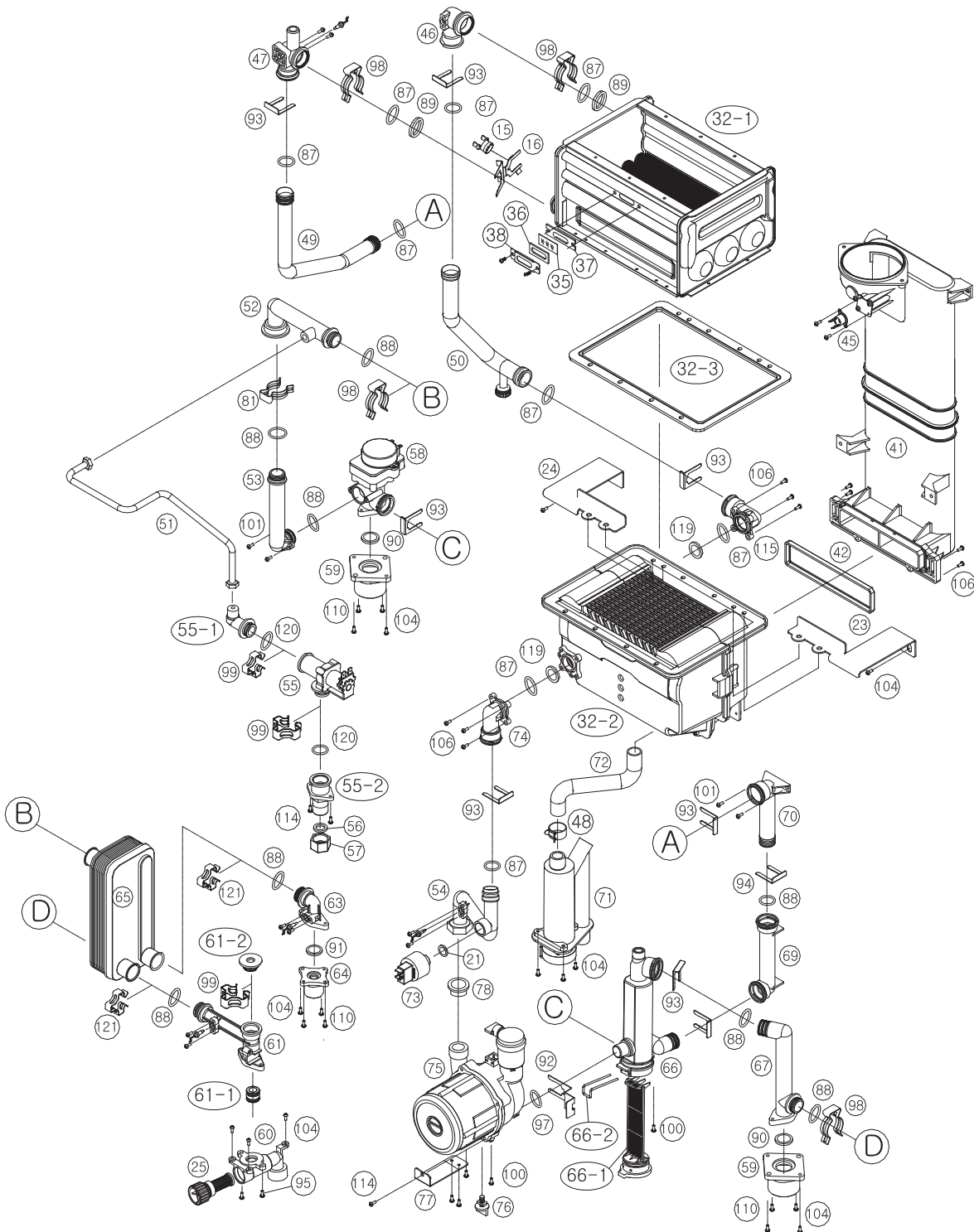

### 3-2. Water Way Part List

NO	Description	Navien Part No.	Remark
15	High Limit Switch	BH1401022A	
16	High Limit Switch Bracket	BH2501541A	
21	WPS Packing	BH2406054A	
23	H/E Bracket R	BH2501704B	
24	H/E Bracket L	BH2501703B	
25	Inlet Water Filter	BH1303013A	
32	Heat Exchanger Ass'y	BBM20341008	210/240
		BBM20341007	180
41	Exhaust Duct	BH2544007D	
42	Exhaust Duct Packing	BH2406050A	
45	Exhaust Limit Switch	BH1401031A	
46	Primary H/E Inlet Adapter	BH2501558A	
47	Primary H/E Outlet Adapter	BH2507602A	
49	H/E Outlet Pipe	BH2507555A	210/240
		BH2507556A	180
50	H/E Middle Pipe	BH2507531B	
51	Auto Feeder Pipe	BH2507552A	
52	SPH Inlet Pipe 1	BH2507367A	
53	SPH Inlet Pipe 2	BH2507366A	
54	H/E Inlet Pipe	BH2507553A	210/240
		BH2507554A	180
55	Auto Feeder Valve	BH0904011A	
56	Auto Feeder Packing	BH2406063A	
57	Auto Feeder Cover	BH0712006A	
58	3-Way Valve	AAVC9EX00009A	
59	S/H Return Adapter	BH2507551A	
60	DHW Inlet Adapter	BH2507560C	
61	DHW Flow Sensor	AASS9EXFS002A	
63	DHW Outlet Pipe Ass'y	BH2507590A	
64	DHW Outlet Adapter	BH2507558A	
65	DHW Heat Exchanger	PAS40KHE_003	210/240
		PAS30KHE_005	180



NO	Description	Navien Part No.	Remark
66	S/H Strainer	BH1301020C	
67	S/H Return Pipe	BH2507550A	
69	S/H Pipe 2	BH2507372B	
70	S/H Pipe 1	BH2507373A	
71	Siphon	BH2501442C	
72	Siphon Hose	BH2204047A	
73	Water Pressure Sensor	BH2507535A	
74	Secondary H/E Inlet Adapter	BH2501603A	210/240
		BH2501602A	180
75	Circulation Pump	NAPU9GLPCT10	
76	Drain Coke	BH2505314A	
77	Pump Bracket	BH2501447A	
78	Pump Packing	BH2406039A	
81	Fastener C	BH2507018B	
87	O-Ring ( $\phi 17.5 \times 2.7t$ )	BH2422026A	
88	O-Ring (P16)	BH2422017A	
89	Back-up Ring	BH2507308A	
90	Packing Ring (3/4")	BH2406025A	
92	Pump Fastener	BH2507445A	
93	Clip A	BH2507013A	
94	Clip C	BH2507345A	
95	Screw D4 x 16L	BH1708004A	
97	O-Ring ( $\phi 24.8 \times \phi 17.8t$ )	BH2423058A	
98	Fastener B	BH2507016A	
99	Fastener D	BH2507402B	
100	Screw D4 x 8L	BH1705007A	
101	Bolt M4 x 16L	BH1603009A	
104	Bolt D4 x 10L (STS)	BH1611006A	
106	Bolt M4 x 12L	BH1612007A	
110	Screw D4 x 14L	BH1701003A	
114	Bolt M4 x 8L	BH1603015A	
119	H/E Packing	BH2406048A	
120	O-Ring (P16)	BH2422017A	
121	Fastener A	BH2507400B	

# Memo

A large, empty rounded rectangular box with a blue border, intended for writing a memo. The box is centered on the page and occupies most of the vertical space below the header.

# Service

## GENERAL TROUBLESHOOTING PROBLEM POSSIBLE SOLUTIONS

### **It takes a long time to get hot water to the fixtures.**

- ▶ Circulation pump is in Freeze protection mode. Circulation pump needs to change hot water circulation mode.

### **The water is not hot enough.**

- ▶ Check ground water temperature first and system setting temperature.
- ▶ Check cross plumbing between cold water lines and hot water lines.

How? Shut off Main cold water supply valve to water heater, which means no water supply to water heater. Open any hot water faucet. If cold water comes from hot side faucet, there is cross hot and cold water lines somewhere in facility.

- ▶ Is the gas supply valve fully open?
- ▶ Is the gas line sized properly?
- ▶ Is the gas supply pressure enough?
- ▶ Is the set temperature too low?

### **The water is too hot.**

- ▶ Is the set temperature set too high?

### **The hot water is not available when a fixture is opened.**

- ▶ Make sure the unit gets 120V 60Hz power supply.
- ▶ Is the gas supply valve fully open?
- ▶ Is the water supply valve fully open?
- ▶ Is the filter on cold water inlet clean?
- ▶ Is the hot water fixture sufficiently open to draw at least 0.5 GPM through the water heater?
- ▶ Is the unit frozen?
- ▶ Is there enough LPG gas in the tank?

### **The hot water turns cold and stays cold.**

- ▶ Is the flow rate enough to keep the Model 35-1 running?
- ▶ If there is a recirculation system installed, does the recirculation line have right check valves?
- ▶ Is the gas supply valve fully open?
- ▶ Is the filter on cold water inlet clean?
- ▶ Are the fixtures clean of debris and obstructions?
- ▶ Check cross plumbing between cold water lines and hot water lines.

### **Hot water temperature fluctuating.**

- ▶ Check incoming cold water pressure whether it is too low. (needs minimum 15PSI)
- ▶ Is the filter on cold water inlet clean?
- ▶ Is the gas line sized properly?
- ▶ Is the supply gas pressure enough?
- ▶ Check for cross connection between cold water lines and hot water lines.

Condensing  
**NAVIENT**  
Navigating Energy and Environment

***Navien Gas Combination Water Heater***



Navien America Inc.  
20 Goodyear Irvine, CA 92168  
Tel: 949 420 0420, Fax : 949 420 0430, Toll Free: 1-800-519-8794  
[www.NavienAmerica.com](http://www.NavienAmerica.com)