

navien Condensing Combi Boiler

Installation & Operation Manual

Getting Service

If your boiler requires service, you have several options for getting service:

- Contact an official Technical Assistance Service (TAS) at 0844 332 2323 or go to the website (www.navien.co.uk).
For warranty service, always contact an official Technical Assistance Service (TAS) first.
- Contact the technician or professional who installed your boiler.
- Contact a Gas Safe Registered engineer.

When contacting an official Technical Assistance Service (TAS), please have the following information available:

- Model number
- Serial number
- Date purchased
- Installation location and type
- Error code, if any appears on the front panel display

Version: 1.1(November, 2021)



Navien LTD

Building 2, Guildford Business Park, Guildford, GU2 8XH
TEL 0844 332 2323 www.navien.co.uk

navien Condensing Combi Boiler

Installation & Operation Manual

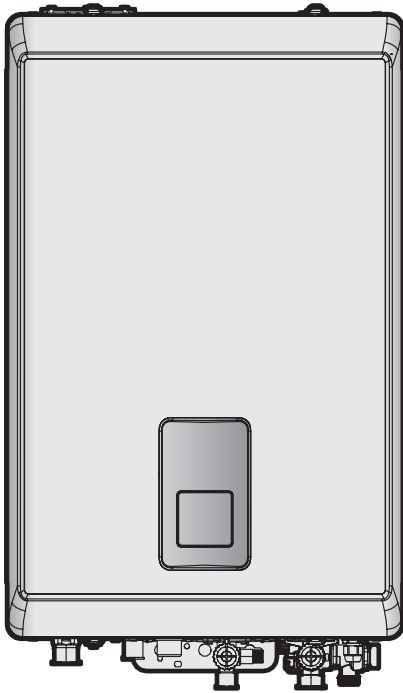

- These appliances are for use with natural gas or LPG. (An LPG conversion kit is included with the boiler.)
- Type: B23-B33-B53-C13-C33-C43-C53-C63-C83

Gas	Model	GC Number
Natural Gas	NCB700-42C NCB700-54C	
LPG	NCB700-42C NCB700-54C	

Keep this manual near this boiler for future reference whenever maintenance or service is required.

WARNING

If the information in these instructions is not followed exactly, a fire or explosion may result, causing property damage or personal injury.

- **Do not store or use petrol or other flammable vapours and liquids in the vicinity of this or any other appliance.**
- **WHAT TO DO IF YOU SMELL GAS**
 - Do not try to light any appliances.
 - Do not touch any electrical switch; do not use any phone in your building.
 - Immediately call the National Gas Emergency Helpline on (Freephone) 0800 111999 or your gas supplier from a neighbour's phone. Follow the instructions received.
- **Installation and service must be performed by a Gas Safe registered installer, service agency or the gas supplier.**



Contents

1. Safety Information	3	7. Setting the DIP Switches	35
2. About the Boiler	7	7.1 PCB DIP Switches	35
2.1 Items Included	7	7.2 Front Panel DIP Switches	35
2.2 Accessories	7	8. Connecting Electrical Supplies	36
2.3 Technical Data	8	8.1 Accessing the Terminal Strips	36
2.4 Components	11	8.2 Connecting the Power Supply Cables	37
2.5 Dimensions	15	8.3 Connecting the Switched Live	38
2.6 Operating Modes	16	8.4 Connecting the Room Stat or OpenTherm	38
2.7 Installation Procedure	18	8.5 Connecting the Outdoor Temperature Sensor	38
3. Installing the Boiler	19	8.6 OpenTherm® Protocol	38
3.1 Choosing an Installation Location	19	8.7 Connecting the Navien Smart Room Controller (Optional)	38
3.2 Mounting the Boiler to the Wall	21	9. Installation Check list	39
4. Installing the System Piping	22	10. Operating the Boiler	40
4.1 Installing a Central Heating System	22	10.1 Using the Front Panel	40
4.2 Installing a Domestic Hot Water (DHW) System	23	10.2 Turning the Boiler On or Off	42
4.3 Connecting the Condensate Drain Line	23	10.3 Start-Up Wizard	42
4.4 Pipe Dimensions and Water Pressure	24	10.4 Adjusting the Temperature	42
4.5 Pressure Relief Valve	25	10.5 Resetting the Boiler	43
4.6 Filling the System	25	10.6 Accessing Basic Menu Items	44
4.7 Testing the Water System	25	10.7 Accessing Advanced Menu Items	49
5. Connecting the Gas Supply	26	10.8 Error Codes	53
5.1 Gas Pipe Material	27	11. Maintaining the Boiler	54
5.2 Propane Gas Installations (LPG)	27	11.1 Cleaning the Boiler	54
5.3 Measuring the Inlet Gas Pressure	27	11.2 Draining the Boiler	54
6. Flue System	29	11.3 Cleaning the Return Adapter Filter	55
6.1 Flue Terminal Positions	29	11.4 Protecting the Boiler from Freezing	55
6.2 Selecting a Flue System	30	11.5 Maintenance Schedules	56
6.3 Coaxial Systems	31	12. Appendices	59
6.4 Dual Duct Systems	32	12.1 Gas Conversion	59
6.5 Measuring Flue Length	34	12.2 Cleaning the Heat Exchanger	64
6.6 Terminating the Flue	34	12.3 Wiring Diagram	67
		12.4 Ladder Diagram	68
		12.5 Outdoor Temperature Sensor (Optional)	69

1. Safety Information

The following safety symbols are used in this manual. Read and follow all safety instructions in this manual precisely to avoid unsafe operating conditions, fire, explosion, property damage or personal injury.

DANGER

Indicates an imminently hazardous situation which, if not avoided, could result in severe injury or death.

WARNING

Indicates a potentially hazardous situation which, if not avoided, could result in injury or death.

CAUTION

Indicates a potentially hazardous situation which, if not avoided, could result in property damage.

DANGER



If you smell gas:

- Do not try to light any appliances.
- Do not touch any electrical switches or use landline phones.
- From a neighbour's phone, call your gas provider and follow their instructions.
- If you cannot reach your gas provider, call the fire department.
- Do not return to your home until authorised by your gas supplier or the fire department.

Do not use or store flammable products, such as petrol, solvents, or adhesives in the same room or area as the boiler.

- The boiler has a main burner flame that can turn on at any time and can ignite flammable vapours. Vapours from flammable liquids can explode and catch fire, causing severe burns.
- Vapours cannot be seen and are heavier than air. They can travel long distances along the ground and can be carried from other rooms to the boiler's main burner flame by air current.
- Keep all flammable products far away from the boiler and store them in approved containers. Keep the containers closed tightly and out of the reach of children and pets.

WARNING

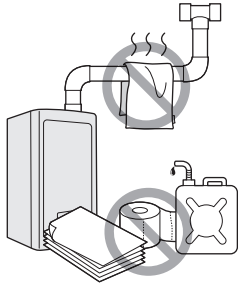

- **Do not store or use petrol or other flammable liquids near this boiler.**
Doing so may result in fire or explosion.
- **Do not place combustibles, such as newspapers or laundry, near the boiler or flue system.**
Doing so may result in a fire.
- **Do not place or use hair sprays, spray paints, or any other compressed gases near the boiler or flue system, including the flue termination.**
Doing so may result in fire or explosion.
- **Do not operate the boiler with the front cover opened.**
Doing so may result in fire or carbon monoxide (CO) poisoning, which may result in property damage or personal injury.
- **Do not operate this boiler without proper flue system.**
Doing so may result in fire or carbon monoxide (CO) poisoning, which may result in property damage or personal injury.
- **Do not touch the power cord or internal components of the boiler with wet hands.**
Doing so may result in electric shock.

WARNING

This appliance can be used by children aged from 8 years and above and persons with reduced physical, sensory or mental capabilities or lack of experience and knowledge if they have been given supervision or instruction concerning use of the appliance in a safe way and understand the hazards involved. Children shall not play with the appliance. Cleaning and user maintenance shall not be made by children without supervision.

⚠ CAUTION

- **Do not turn on the boiler unless the water and gas supplies are fully opened.**
Doing so may damage the boiler.
- **Do not turn on the water if the cold water supply shut-off valve is closed.**
Doing so may damage the boiler.
- **Do not use this boiler for anything other than its intended purpose, as described in this manual.**
- **Do not remove the front cover unless the power to the boiler is turned off or disconnected.**
Failure to do so may result in electric shock.
- **When servicing the controls, label all wires prior to disconnecting them.**
Failure to do so may result in wiring errors, which can lead to improper or dangerous operation. Verify proper operation after servicing.
- **Do not use unapproved replacement or accessory parts.**
Doing so may result in improper or dangerous operation and will void the manufacturer's warranty.
- **Do not place anything in or around the flue terminals, such as a clothes line, that could obstruct the air flow in or out of the boiler.**
- **This boiler has been approved for use the UK and Ireland only.**
Using the boiler in any other country will void the manufacturer's warranty.

⚠ DANGER



To prevent burns:

- Use the lowest operating temperature setting necessary to provide comfortably hot water.
- If your household has children or elderly or disabled residents, consider using a lower temperature setting.
- Read all the instructions in this manual carefully before changing the temperature setting.
- Feel the water before using it on children, the elderly, or the disabled.

⚠ DANGER

This boiler's water temperature is set to 49°C at the factory for your safety and comfort. Increasing the temperature increases the risk of accidental scalding. Water temperatures at or above 52°C can cause instant scalding or severe burns. Before you decide to change the temperature setting, read the following charts carefully.

Water Temperature	Time in which a young child can suffer a full thickness (3rd degree) burn
70°C	Less than 1 second
60°C	1 second
55°C	10 seconds
49°C	10 minutes
37°C	Very low scald risk

General Installation Guidelines

Navien ensures that this product contains no harmful substances and that no harmful materials have been used in its manufacture.

Current legislation must be taken into account on installing this appliance, and it must be installed in a place with suitable ventilation.

The boiler must be installed by an installer authorised by the Ministry of Industry and it must be started up by an Official Technical Assistance Service authorised by Navien.

The requirements included in the following regulations must be observed on installing the boiler:

- The Gas Installation Regulation.
- The Technical Building Code.
- The Regulation for Heating Installations in Building.
- The Low Voltage Regulation.

Installation in hard water areas

- In areas with hard water (hardness exceeding 200 ppm), it is important to install a scale reducer.
The advice of the local water authority should be sought.

Installing the system piping

- The boiler is equipped with an internal relief valve. All systems must be capable of sustaining pressure of up to 3 bar.
- The air vent is required in the system during filling.

CAUTION

The boiler is equipped with an internal bypass valve. The internal bypass valve is not intended to replace an external bypass valve. An external automatic bypass valve is required if a zone valve has been connected to the system.

Gas Conversion

The boiler is configured for natural gas. If LPG conversion is required, use the conversion kit supplied with the boiler and attach the item matching the LPG GC No. (included in the kit).

The Codes of good practice and regulations refer to the latest versions of the same.

The installation must also comply with the following European Standards:

Standard	Description
UNE-EN 13831:2008	Closed expansion vessels with diaphragm.
UNE-EN 1856	Metal chimneys
UNE-EN 13384	Chimneys
UNE-EN 13779	Ventilation
UNE-EN ISO 16484	Building control systems.
UNE-EN 14336	Heating systems in buildings.
UNE-EN 15502-1	Gas-fired heating boilers Part 1: General Requirements and tests
UNE-EN 15502-2-1	Gas-fired heating boilers Part 2-1: Specific standard for type C appliances and type B2, B3 and B5 appliances of a nominal heat input not exceeding 1000 kW
UNE-EN 13203:2007	Domestic Hot Water
UNE-EN 303-7:2008	Heating boilers.

EC Conformity Declaration



Navien, hereby declares that the boiler models:

NCB700-42C, NCB700-54C

to which this declaration refers, conform to and comply with the essential requirements of the following applicable European Standards and Directives.

Gas appliances: Regulation (EU) 2016/426
Standards EN15502-1, EN15502-2-1 and EN437

Boiler Efficiency: Directive 92/42/EEC
Regulation (EU) No.813/2013
Standards EN15502-1, EN15502-2-1

Low voltage: Directives 73/23/EEC and
93/68/EEC Standards EN 60335-1, EN 60335-2-30,
EN 60335-2-51, EN 50165

Electro-magnetic Compatibility: Directive 2004/108/EC
Standards EN 55014



Pressure Vessels: Directive 97/23/EEC

Navien, manufactures its products using a Quality Assurance system in compliance with Standard EN-ISO 9001:2000.

2. About the Boiler

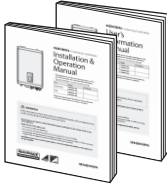
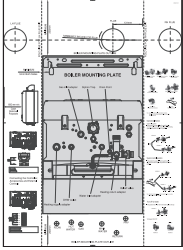
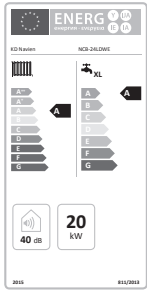
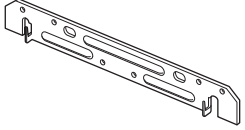
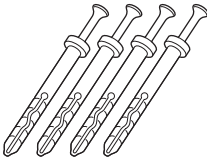

2.1 Items Included

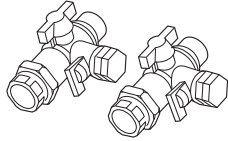
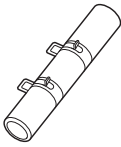
When you open the box, you will find the following items with the boiler. Check the box for each of the following items before installing the boiler. If it seems like there is a problem, do not use the boiler. Contact your supplier. Keep the included items out of the reach of children, as they can be dangerous. When you no longer wish to use the boiler, disable any parts that could be potentially hazardous.

			
Installation & Operation Manual, User's Information Manual	Boiler mounting plate	ErP Label	Wall mounting bracket
			
Tapping screws & anchors	Propane gas changing kit	Electric cord	Pre-plumbing Kit
			
Condensate trap hose			

2.2 Accessories

The following optional accessories are available for the boiler:

	
Outdoor Temperature Sensor	Smart Room Controller

2.3 Technical Data

The following table lists the general specifications for the boiler.

Specifications	Unit	NCB700-42C	NCB700-54C
Heat input range	kW	34.8/3.5	34.8/3.5
DHW heat input range	kW	40.8/3.5	52.4/3.5
Heat output range @ 80/60°C	kW	34.0/3.4	34.0/3.4
DHW output range	kW	42.0/3.5	42.0/3.5
Condensing heat output range @ 50/30°C	kW	37.2/3.7	37.2/3.7
Full load efficiency at Max./Min. output @ 80/60°C	%	97.0/97.0	97.0/97.0
Full load efficiency at Max./Min. output @ 50/30°C (Condensing)	%	107.0/107.8	107.0/107.8
Partial load (30%) efficiency with 47°C return temp.	%	103.0	103.0
Partial load (30%) efficiency with 30°C return temp.	%	108.5	108.5
Heat loss through the case with burner switched on	%	0.1	0.1
Heat loss through the chimney with burner switched on	%	1.9	1.9
Seasonal efficiency rate (SEDBUK 2009)	-	89.1	89.1
NOx Classification	-	Class 6	
Category	-	II2H3P	
Type	-	Heating and instantaneous hot water production	
Heat output adjustment	-	Adjustable over entire Max./Min. output range	
Type of heating installation	-	Close circuit	
Max. heating operation pressure	bar	2.5	
Max. heating temperature	°C	90	
Adjustable heating temperature range	°C	40-90	
Expansion vessel volume	l	10.0	
Expansion vessel pre-charged pressure	bar	1.0	
Min. DHW working pressure	bar	1.2	1.2
Min. DHW working flow	l/min	2.0	
Max. DHW working pressure	bar	10	
Adjustable DHW temperature range	°C	30-65	
DHW flow rate @ 25°C temp. rise.	l/min	24.1	31.0
DHW flow rate @ 30°C temp. rise.	l/min	20.1	25.8
DHW flow rate for kitchen @ 45°C temp. rise.	l/min	13.4	17.2
Electrical power supply	-	230 V/50 Hz	
Nominal current	A	0.62	
Max. power consumption	W	140	
Appliance protection rating	-	IP X5D	
Boiler mounting system type	-	Wall-mounted	

Specifications		Unit	NCB700-42C	NCB700-54C
Flue exhaust/Air intake system types		-	B23-B33-B53-C13-C33-C43-C53-C63-C83	
Flue exhaust/Air intake system diameters		mm	Coaxial Ø60/100 and Ø80/125–Dual duct Ø80/80	
Max. gas pipe pressure drop		Pa	294	294
Max. horizontal coaxial length Ø60/100		m	20	
Max. vertical coaxial length Ø60/100		m	21	
Equivalent elbow length @ 90° Ø60/100		m	1.3	
Equivalent elbow length @ 45° Ø60/100		m	1.0	
Max. horizontal coaxial length Ø80/125		m	68	
Max. vertical coaxial length Ø80/125		m	70	
Equivalent elbow length @ 90° Ø80/125		m	2.2	
Equivalent elbow length @ 45° Ø80/125		m	1.0	
Equivalent length of adapter Ø60/100 => Ø80/125		m	0.5	
Max. dual duct length Ø80/80		m	110	
Equivalent elbow length @ 90° Ø80		m	2.2	
Equivalent elbow length @ 45° Ø80		m	1.4	
Hydraulic connection diameter	Central Heating	mm	22	
	DHW	mm	15	
	Gas supply	mm	22	
Dimensions (Width x Depth x Height)		mm	440 x 335 x 695	
Total boiler weight (lift weight)		Kg	43	46

The following table lists the product information requirements (EU regulation No 811/2013 and No 813/2013)

KD Navien	Symbol	Unit	NCB700-42C	NCB700-54C
Condensing boiler			YES	YES
Low-temperature (**) boiler			NO	NO
B1 boiler			NO	NO
Cogeneration space heater			NO	NO
Combination heater			YES	YES
Rated heat output	P_{rated}	kW	34	34
Seasonal space heating energy efficiency	η_s	%		
Useful heat output				
At rated heat output and high-temperature regime (*)	P_4	kW	34.0	34.0
At 30 % of rated heat output and low-temperature regime (**)	P_1	kW	10.2	10.2
Useful efficiency				
At rated heat output and high-temperature regime (*)	η_4	%		
At 30 % of rated heat output and low-temperature regime (**)	η_1	%		
Auxiliary electricity consumption				
At full load	e_{lmax}	kW		
At part load	e_{lmin}	kW		
In standby mode	P_{SB}	kW		
Other items				
Standby heat loss	P_{stby}	kW		
Ignition burner power consumption	P_{ign}	kW		
Annual energy consumption	Q_{HE}	GJ		
Sound power level, indoors	L_{WA}	dB		
Emissions of nitrogen oxides	NO_x	mg/kWh		
For combination heaters				
Declared load profile				
Daily electricity consumption	Q_{elec}	kWh		
Annual electricity consumption	AEC	kWh		
Water heating energy efficiency	η_{wh}	%		
Daily fuel consumption	Q_{fuel}	kWh		
Annual fuel consumption	AFC	GJ		
Contact details	Navien LTD, Building 2, Guildford Business Park, Guildford, GU2 8XH			

(*) High-temperature regime means 60 °C return temperature at heater inlet and 80 °C feed temperature at heater outlet.

(**) Low temperature means for condensing boilers 30 °C, for low-temperature boilers 37 °C and for other heaters 50 °C return temperature (at heater inlet).

Specific precautions

Read the user's information and installation manual before the application is assembled, installed or maintained.

2.4 Components

The following diagram shows the key components of the boiler. Component assembly diagrams and particular parts lists are included in the Appendices.

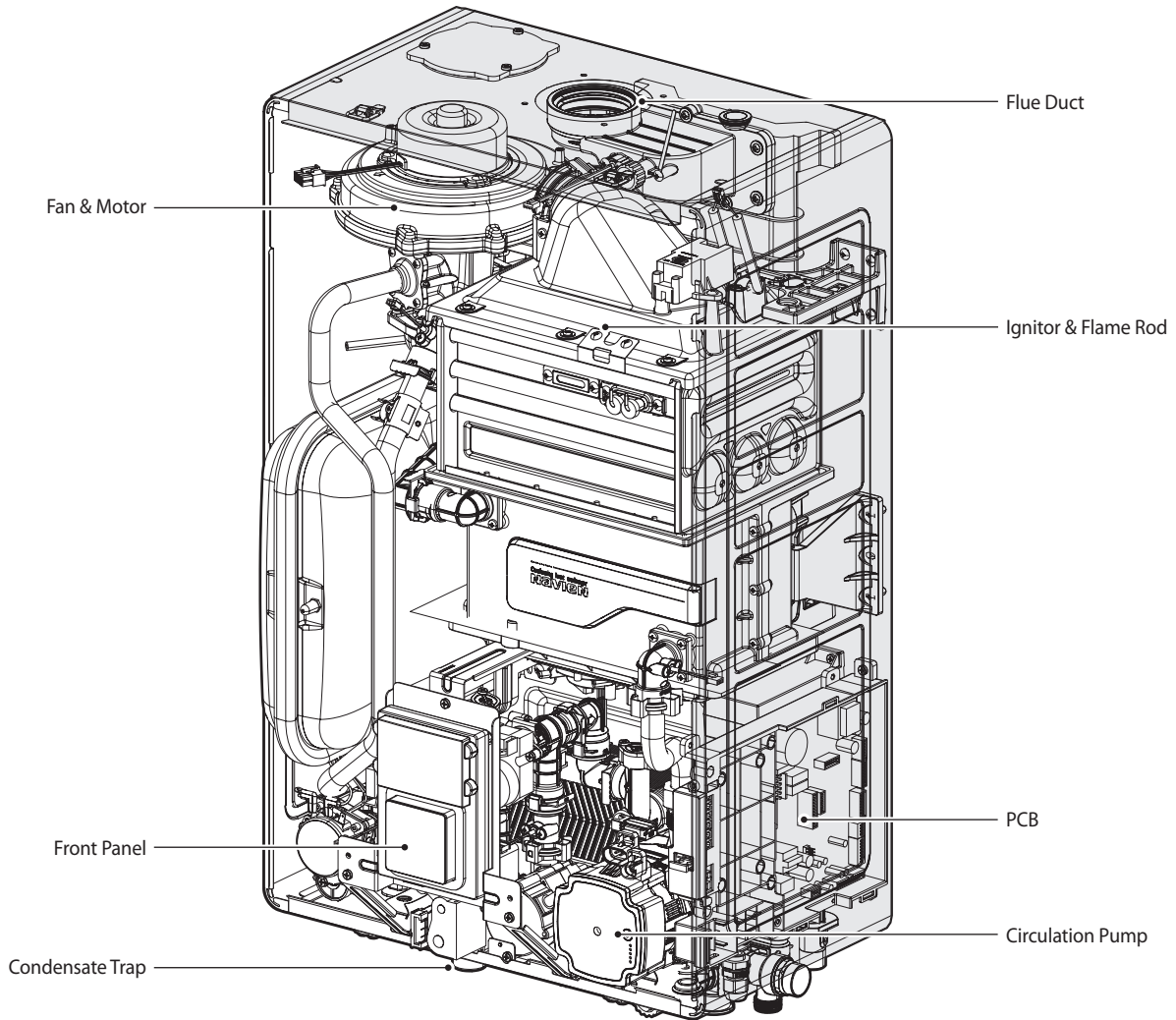

NCB700-42C

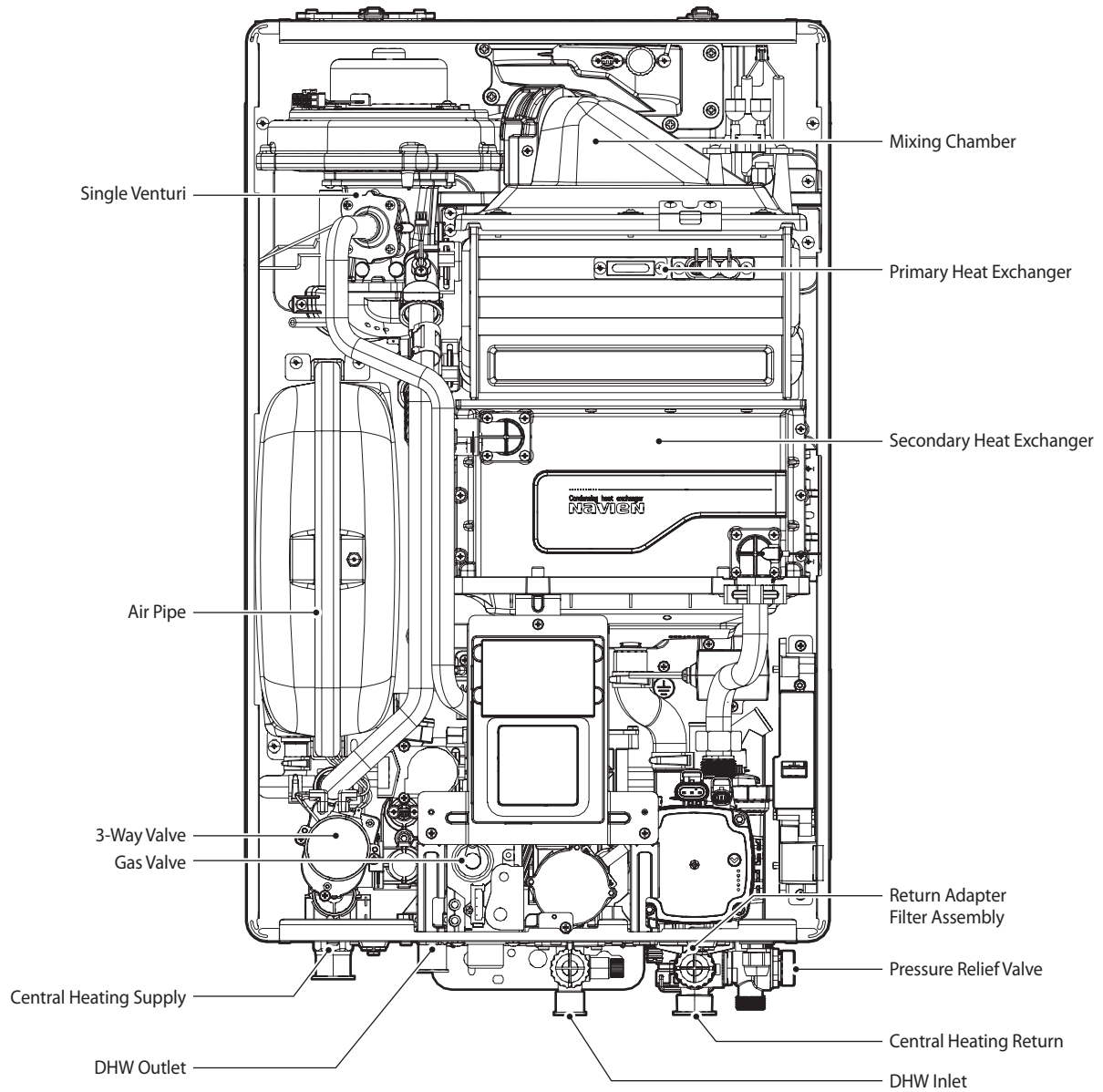

NCB700-42C

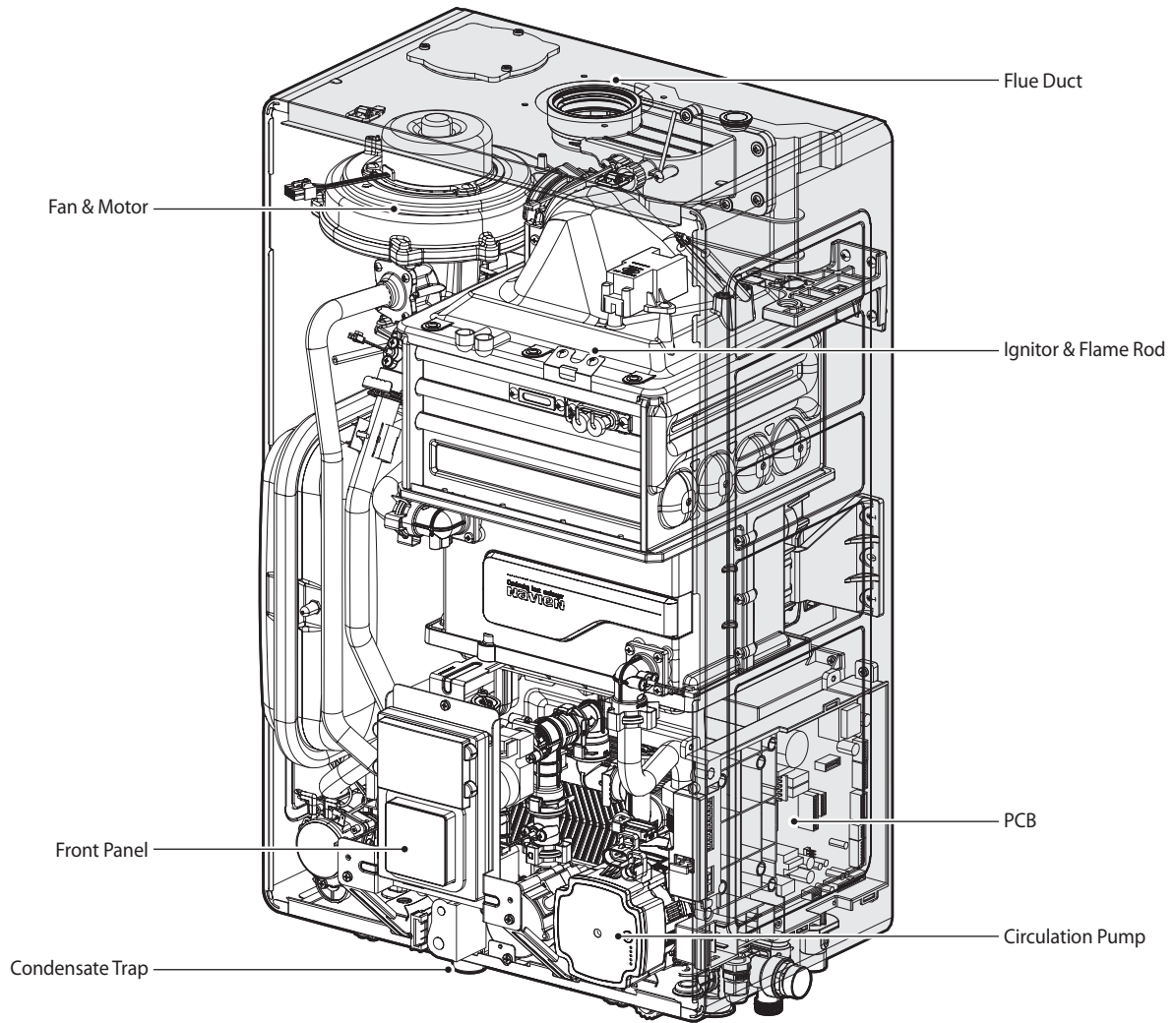

NCB700-54C

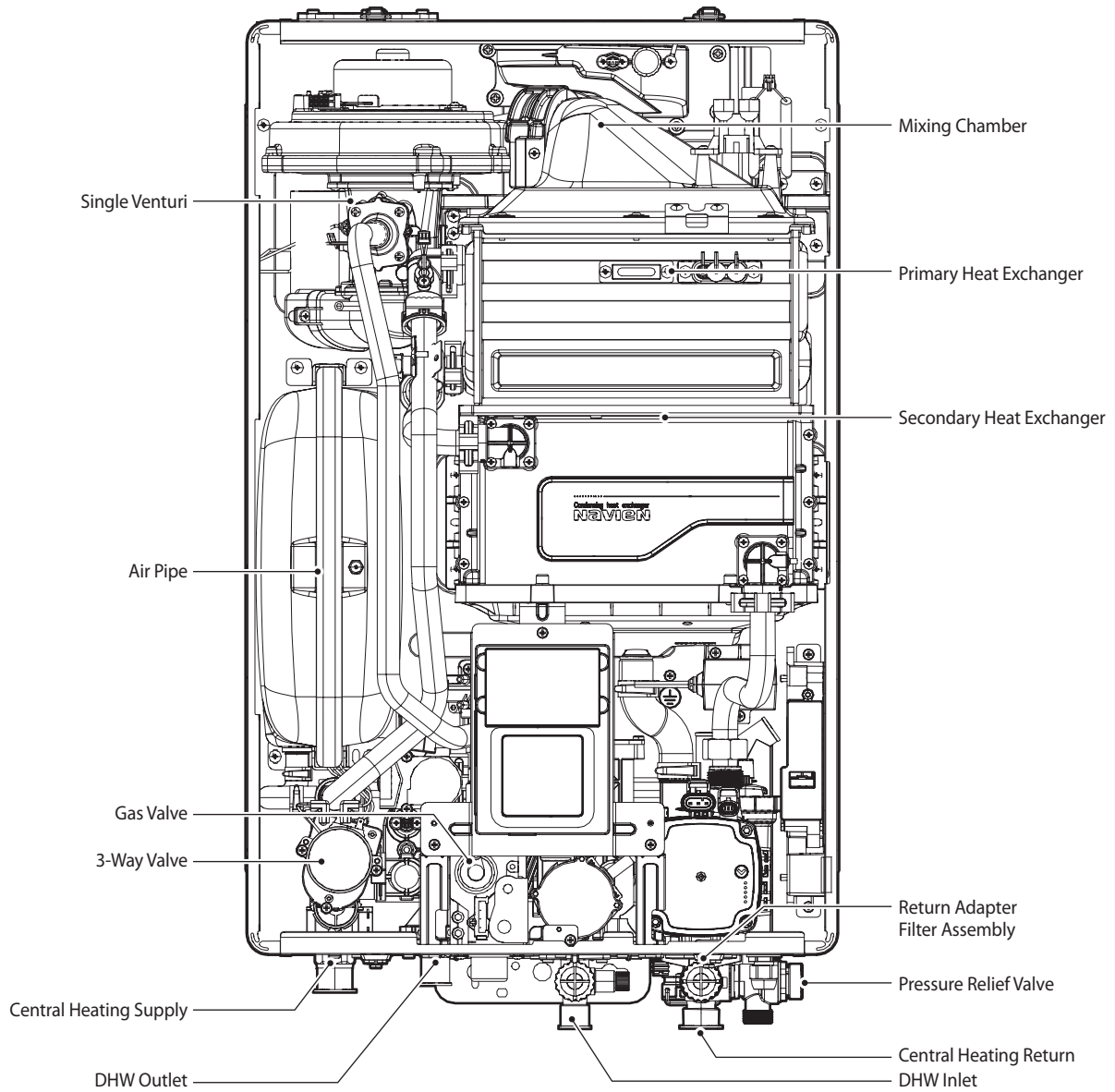

NCB700-54C

2.5 Dimensions

The following diagrams show the dimensions of the boiler and the table lists the supply connections.

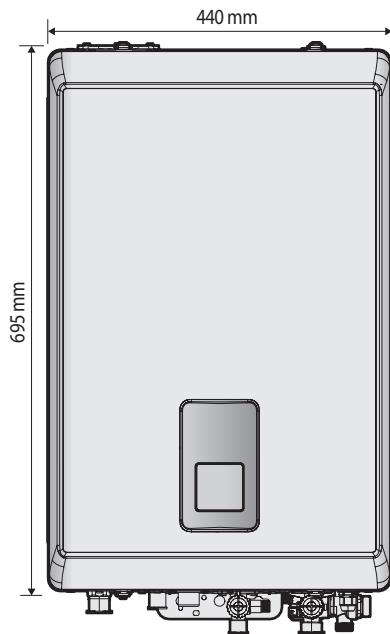

Supply Connections

	Description	Diameter
A	Flue exhaust/Air intake	Ø60/100, Ø80/125
B	Central heating supply	22 mm
C	Hot water outlet (DHW)	15 mm
D	Gas supply inlet	22 mm
E	Cold water inlet (DHW)	15 mm
F	Central heating return	22 mm

Overhead View

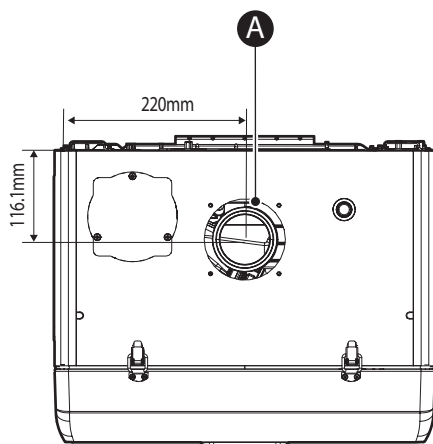

Bottom View

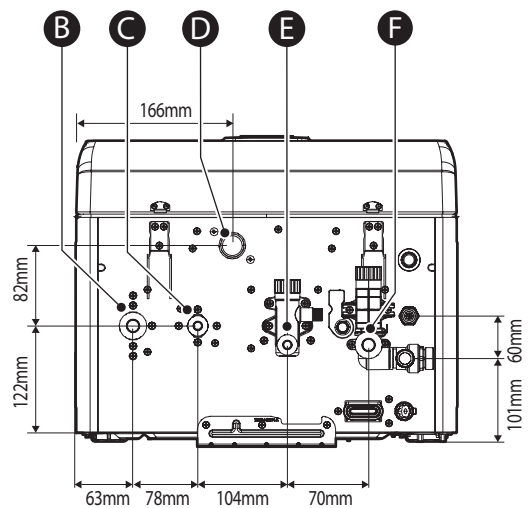

2.6 Operating Modes

2.6.1 Operating in Central Heating Mode

To operate the central heating mode:

1. Press the Menu button (M) to access the Main menu and select "2. Central Htg Operation" by pressing the OK button (OK).

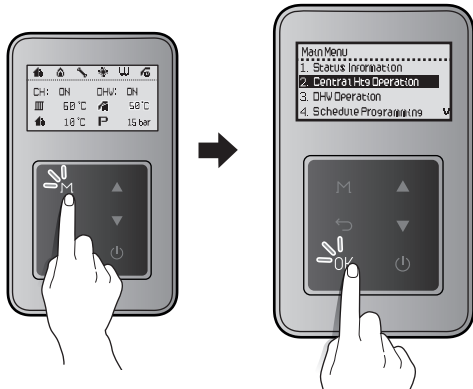

2. In the Central Htg Operation menu, select "1. Central Htg ON/OFF" and select "Enable". Then, select "1-1 CH Set Temp" and select a heating temperature setpoint higher than current heating temperature.
 - When the boiler detects a request for heating production (from the installation's room thermostat, for example), the 3-way valve goes to heating position and the circulating pump starts up.
 - If the boiler water temperature is lower than the desired temperature setpoint, the boiler ignites and heats up the heating installation until the selected boiler temperature is reached. The boiler's electronic control modulates the burner output to adapt to the installation's heat requirements at all times and so that the installation's water temperature remains constant. This prevents the installation from overheating and reduces heat loss as much as possible.
 - When there is no further heating demand (e.g. when the desired ambient temperature selected on the room thermostat is reached), the burner is extinguished (if it was ignited) and the circulation pump continues to run during the post-circulation time (minimum 3 minutes), to protect the boiler from overheating due to thermal inertia in the installation.

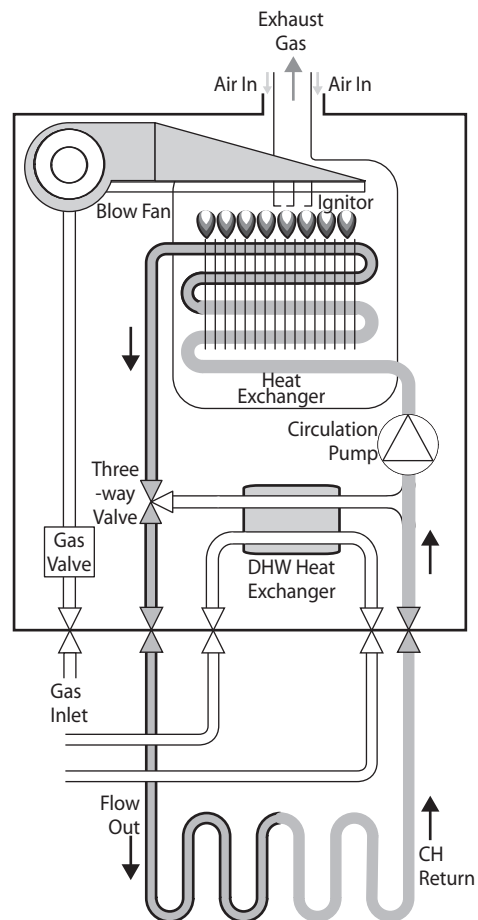

2.6.2 Operating According to Outdoor Temperature Conditions

The Outdoor Reset Control feature may be used to enhance energy efficiency while maintaining optimal heating performance. With the Outdoor Reset Control, the central heating temperature setting automatically changes according to the outdoor temperature and the K-Factor setting.

You can configure the Outdoor Reset Control settings on the front panel in the Central Htg Operation menu. Refer to "10.6.2 Setting the Central Heating Operation" on page 45.

Note The Outdoor Reset Control feature requires installation of an outdoor temperature sensor, and it only works when the boiler is running in the normal operation mode. It does not work when the boiler's front panel displays a fault.

The following table lists the central heating temperature range by k-factor setting value and the applicable outdoor temperature range.

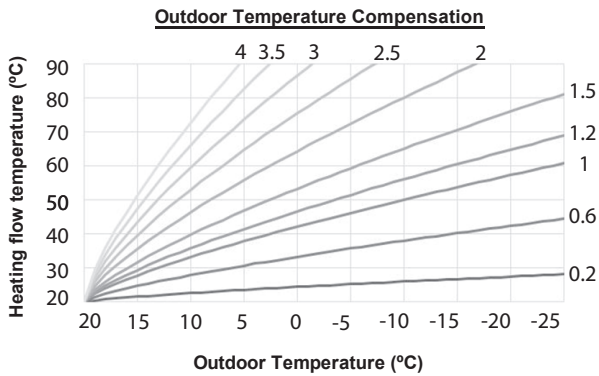

Note To connect the outdoor temperature sensor to the boiler, carefully follow the connection instructions provided in the “12.5 Outdoor Temperature Sensor (Optional)” on page 69.

2.6.3 Operating in DHW Mode

To operate the DHW mode:

1. Press the Menu button (M) to access the Main menu and select “3. DHW Operation” by pressing the OK button (OK).

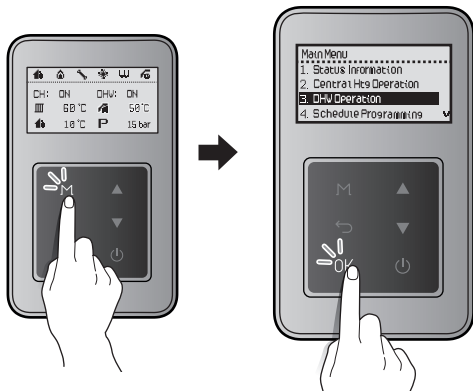

2. In the DHW Operation menu, select “1. DHW Set Temp” and select a DHW temperature setpoint higher than current DHW temperature.
 - When a hot water tap is turned on in the home, the boiler flow meter detects DHW demand, the 3-way valve goes to DHW mode and the circulation pump starts up, which makes the water in the boiler primary circuit flow through the DHW heat exchanger, producing instant hot water.
 - The electronic control modulates the burner output in order to constantly produce hot water at the temperature required.

- When there is no further DHW demand, the burner switches off and the 3-way valve remains in DHW mode position during a wait time (5 minutes by default), so that it can work more efficiently and provide more flexibility if the taps are continuously turned on and off.
- When the wait time has elapsed, the 3-way valve returns to the Heating mode position and the boiler is ready to provide heating.

- Note**
- DHW priority: Whenever a hot water tap is turned on in the home, the boiler begins to run in DHW mode and the heating function is deactivated until all the taps are turned off again.
 - When the boiler water pressure drops below 0.4 bar the automatic fill function is activated.

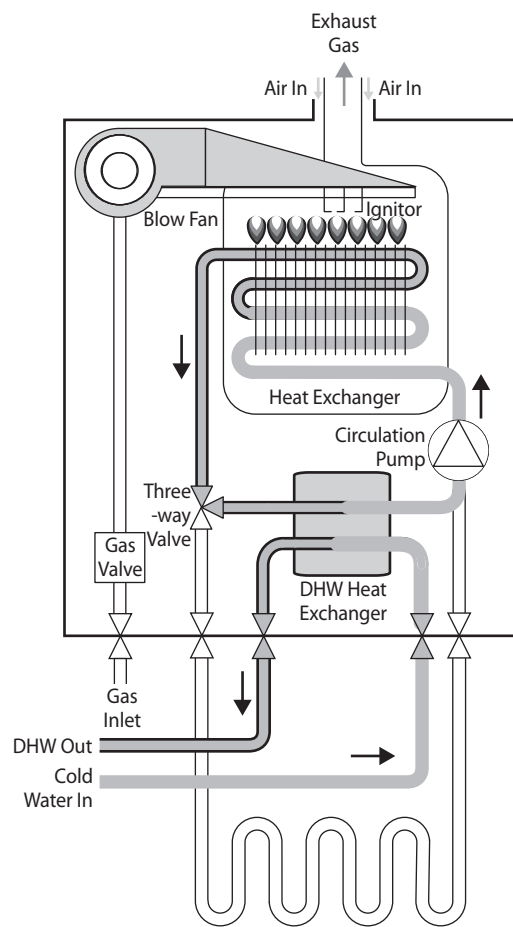

2.7 Installation Procedure

The flow diagram below provides a step-by-step description of the recommended procedure for clear, easy installation of the NCB700 boiler in its final location. A detailed description is given of the procedure in the sequenced sections below:

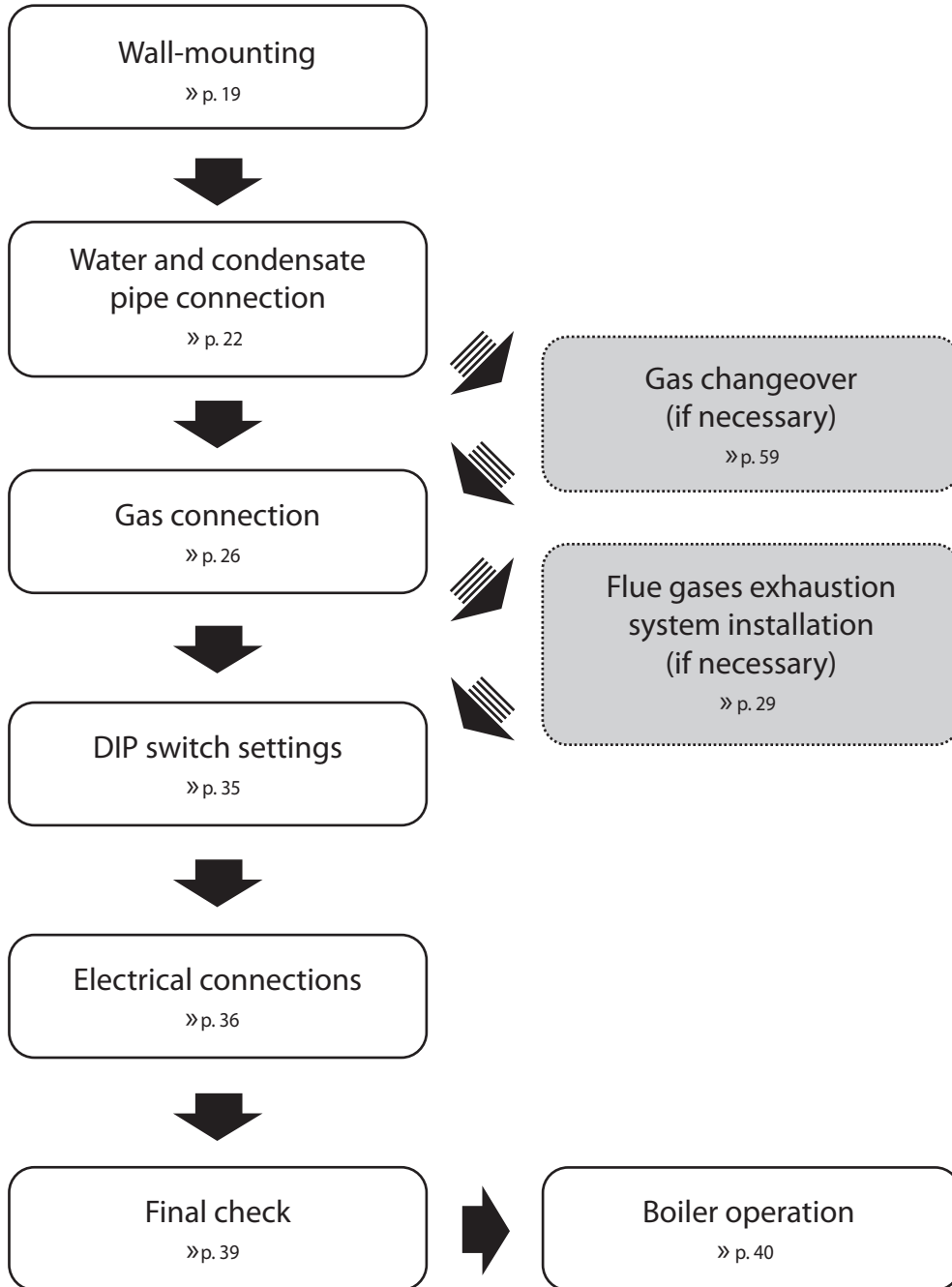

3. Installing the Boiler

3.1 Choosing an Installation Location

When choosing an installation location, you must ensure that the location provides adequate clearance for the boiler, adequate flue and drainage options, and sufficient access to gas, water, and electrical supplies.

Carefully consider the following factors when choosing an installation location:

Compliance Requirements

This boiler must be installed by qualified personnel in compliance with the applicable Laws and Regulations. In general, these Laws and Regulations are the Basic Gas Installation Standards, the Heating, Air Conditioning and Domestic Water Installation Regulation and all other local regulations.

Access to Utilities

- Water—the installation location should be near where the domestic water supply enters the building.
- Gas—the installation location should be near where the gas supply enters the building.
- Electricity—the installation location should be near where the electrical supply enters the building.

Humidity and Contact with Water

When installing the boiler, avoid places with excessive humidity. The boiler has electric gas ignition components. Water spray or droppings can get inside the boiler and damage the ignition system. The boiler must be installed in a way to ensure that the gas ignition system components are protected from water (dripping, spraying, rain, etc.) during operation and service.

If the boiler is installed in a very humid room (a shower room or bathroom, for example), the Low Voltage regulation and the Technical Building Code must be observed for correct installation.

Proximity to Fixtures and Appliances

Install the boiler near fixtures that deliver or use hot water, such as bathroom, kitchen, and laundry room faucets. Select a location that minimises the water piping required between major fixtures. If the distances are long or if the user requires “instant” hot water, installation of a recirculation line which circulates domestic hot water back to the boiler from the furthest fixture is recommended. Insulate as much of the hot water supply and recirculation lines as possible. For more information about the water supply, refer to “4.2 Installing a Domestic Hot Water (DHW) System” on page 23.

Adequate Drainage

The boiler produces a significant amount of condensate during operation. This condensate must be removed from the boiler, and suitably treated if national legislation so requires. The boiler should be located near a suitable drain and where damage from a possible leak will be minimal. Installing the boiler in a location without a drain will void the warranty and Navien will not be responsible for water damage that occur as a result. For more information about condensate drainage, refer to “4.3 Connecting the Condensate Drain Line” on page 23.

The boiler must be located in an area where leakage of the unit or connections will not result in damage to the area adjacent to the appliance or to lower floors of the structure. When such locations cannot be found, installation of an adequately drained drain pan under the boiler is highly recommended. When installing the drain pan, ensure that the installation does not restrict combustion air flow.

Adequate Flue and Ventilation

No specific ventilation is required in the room the boiler is installed in. If it is installed in a cupboard or compartment, no specific ventilation is required, providing the aforementioned dimensions are observed. The requirements and recommendations stipulated in the Regulation for Heating Installations in Buildings (RITE) and any other applicable legislation in this field must be observed.

Select a location that requires minimal flue. Consider flue restrictions caused by windows, doors, air intakes, gas meters, foliage, and other buildings. For more information about flue system, refer to “6. Flue System” on page 29.

To ensure adequate flue and ventilation, follow these guidelines:

- Maintain proper clearances from any openings in the building.
- Install the boiler with a minimum clearance of 300 mm above an exterior grade or as required by local codes.
- Do not enclose the flue termination.
- Install the exhaust flue in an area that is free from any obstructions, where the exhaust will not accumulate.
- Do not install the boiler where moisture from the exhaust may discolour or damage walls.
- Do not install the boiler in bathrooms, bedrooms, or any other occupied rooms that are normally kept closed or not adequately ventilated.

The requirements and recommendations stipulated in the Regulation for Heating Installations in Buildings (RITE) and any other applicable legislation in this field must be observed.

Adequate installation clearances

CAUTION

Do not install the boiler on carpeting.

Install the boiler in an area that allows for service and maintenance access to utility connections, piping, filters, and traps. Based on the installation location, ensure that the following clearances are maintained:

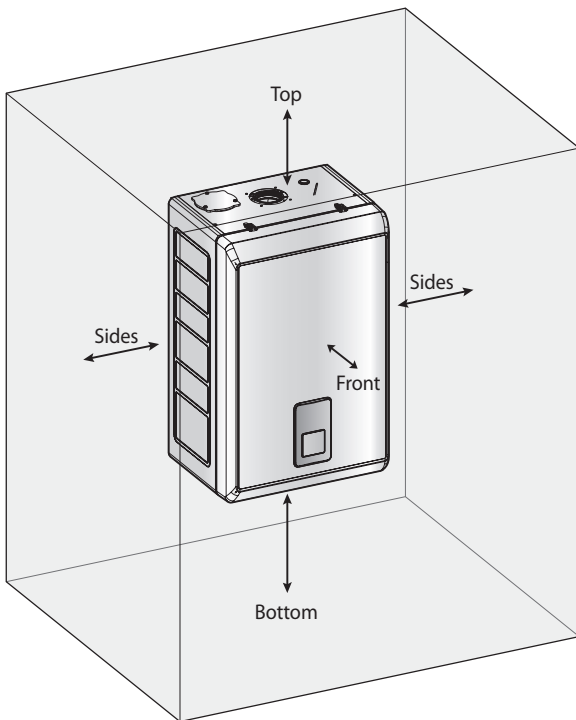

Clearance from:	Indoor Installation
Top	250 mm minimum
Front	600 mm minimum
Bottom	200 mm minimum
Sides	5 mm minimum

Clean, debris and chemical-free combustion air

- Do not install the boiler in areas where dust and debris may accumulate or where hair sprays, spray detergents, chlorine, or similar chemicals are used.
- Do not install the boiler in areas where petrol or other flammables are used or stored.
- Ensure that combustible materials are stored away from the boiler and that hanging laundry or similar items do not obstruct access to the boiler or its flue system.

3.2 Mounting the Boiler to the Wall

Navien NCB700 boilers come with an upper mounting bracket that is pre-drilled at 400 mm on center for easy installation on standard wall studs. If the strength of the wall is insufficient or if the framing is non-standard or uneven, reinforce the area before installing the boiler. Avoid installation on common walls as the unit will make some operational noises while it is running.

To mount the boiler to the wall:

1. Affix the bracket securely to the wall and ensure that it is level and that it can support the weight of the boiler.
2. Align the grooves on the back of the boiler with the tongues on the mounting bracket and hang the boiler on the bracket.

When mounted with the mounting bracket, the boiler will have a 16 mm clearance from the back of the wall.

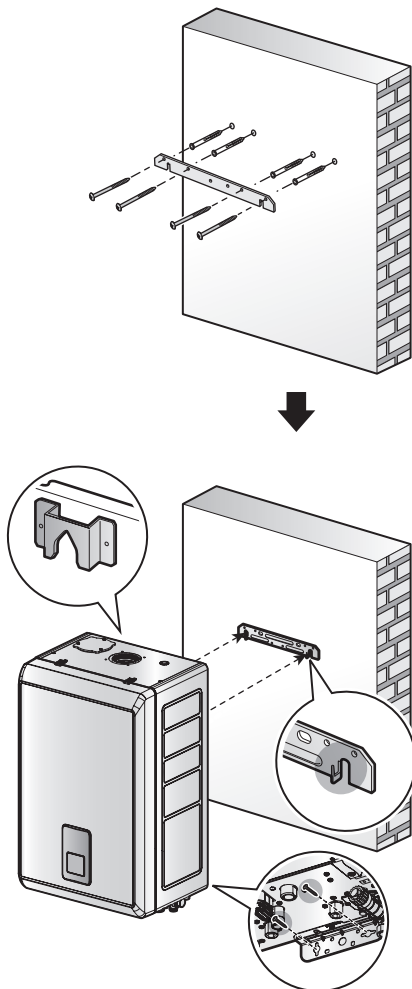

WARNING

- The boiler is heavy. Always lift the unit with assistance. Be careful not to drop the boiler while lifting or handling it to avoid bodily injury or damage to the unit.
- Do not rest the boiler on the bottom end after removing it from the shipping carton. Doing so may result in excessive pressure on protruding pipes and result in product damage. If you must put the boiler down, lay it on its back or put it inside the protective shipping base.

DANGER

- The boiler must be mounted on a suitable wall that can support its weight and prevent explosion or fire.
- Do not install the boiler near paper or other flammable objects.
- Do not install the boiler near domestic waste.

4. Installing the System Piping

The installation must be made by sufficiently qualified technicians, authorised to do so. For correct installation, all the requirements and recommendations described in the Regulation for Heating Installations in Buildings (RITE) must be complied with, together with all other national and/or local regulations applicable at the time of installation. However, the following recommendations must be complied with:

- Before connecting the boiler hydraulically, the inside of the pipes must be thoroughly cleaned, removing all sediment of any type which could cause oxidation or damage to the heat exchanger.
- It is recommended to fit shut-off valves to the heating installation output and return pipes, to avoid having to drain the installation when maintenance work is carried out on the boiler.
- Bleed the air from the boiler and heating installation. Ensure there is no air in the heating circuit.
- The NCB700 boiler is a condensing boiler, and it is therefore essential for the condensate outlet to lead to a drain, in compliance with all applicable national and/or local regulations to this respect.
- The boiler drain must not be located above a window, entry door or other public point of access. Bear in mind that boiling water or steam could come out when draining.
- Draining must be done in a downward direction and towards the walls.

WARNING

- Tighten the boiler water connections, taking care not to damage them. Do not force the tube connections excessively, as this could damage the connections and cause leaks.
- Any dirt in the tubes could reduce boiler efficiency and cause it to malfunction.
- Any pipes exposed to the elements or which could freeze in winter must be insulated with suitable insulating material.

CAUTION

Failure to follow the instructions provided in this section will void the warranty and may result in property damage, fire or serious injury.

4.1 Installing a Central Heating System

The primary and secondary heat exchangers of the Navien NCB700 boiler are designed to attain the highest level of heat transfer in a compact design. To accomplish this, the heating water flows through a series of tubes (secondary heat exchanger) and finned tubes (primary heat exchanger), designed to maximise the heat transfer area. To maintain the efficient and reliable operation of the heat exchangers, and to avoid heat exchanger failure, it is critical to ensure the rules and guidelines in this section are followed.

CAUTION

- The installation must be made by sufficiently qualified technicians, authorised to do so.
- For correct installation, all the requirements and recommendations described in the Regulation for Heating Installations in Buildings (RITE) must be complied with, together with all other national and/or local regulations applicable at the time of installation.

Refer to the following illustration for a typical DHW piping example for the boiler.

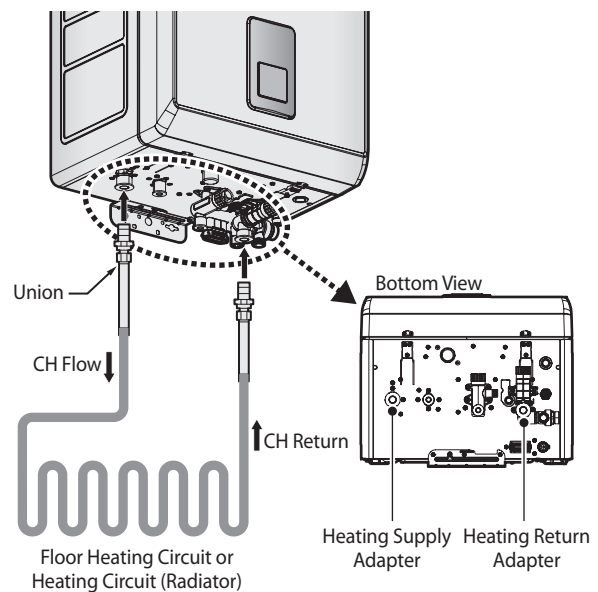

When connecting the central heating system, follow these guidelines:

- Tighten the connection valves with care to avoid damage.
- Test the boiler for proper central heating flow and inspect for leaks.

4.2 Installing a Domestic Hot Water (DHW) System

The Navien NCB700 boiler provides domestic hot water continuously when flow is sensed by the flow sensor. This method is the most efficient means of heating water by allowing the boiler to operate at a lower return water temperature by minimizing standby losses, thus increasing combustion efficiency.

! CAUTION

- The installation must be made by sufficiently qualified technicians, authorised to do so.
- For correct installation, all the requirements and recommendations described in the Regulation for Heating Installations in Buildings (RITE) must be complied with, together with all other national and/or local regulations applicable at the time of installation.

Refer to the following illustration for a typical DHW piping example for the boiler.

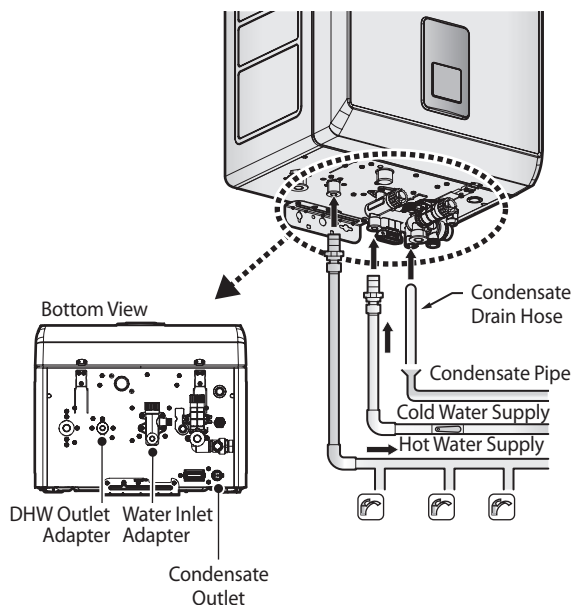

When installing the DHW system, follow these guidelines:

- Use only pipes, fittings, valves, and other components (such as solder), that are approved for use in potable water systems.
- Tighten the connection valves with care to avoid damage.
- Keep the hot water piping system as short as possible, to deliver hot water to the fixtures more quickly.
- After installing the boiler, clean the cold water inlet filter. Then, test the boiler for proper DHW supply and inspect for leaks.

4.3 Connecting the Condensate Drain Line

The Navien NCB700 boiler creates condensation when it operates. This condensation has an acidic pH of 3-5. Follow all local codes and regulations when disposing of condensate from the boiler. We recommend draining the condensate into a laundry tub, as the alkali in laundry detergent will neutralise the acid in the condensate. However, other suitable waste drain locations may be used according to the local legislation.

! CAUTION

- Do not cap or plug the integrated condensate line. If prevented from draining, condensate can damage the boiler.
- The condensate line must have a negative slope to drain properly.

The requirements recommended for the condensate drain line installation are as follows:

- For correct condensate drain line installation, the tube must have a minimum diameter of $\text{Ø}21.5$ mm.
- The tube must be made of a material that can withstand corrosion, e.g. PVC, PVC-U, ABS, PVC-C or PP. It must not be made of metal.
- For safety reasons, the end of the tube must be as close as possible to the draining point.
- When the condensate drainage is connected to a general drain network inside the building, the effects of overpressure that could occur inside it must be taken into account, installing suitable pressure release and ventilation elements.
- The length of the tubes outside the building must be as short as possible. They must also be installed with as much tilt as possible. The tubes must be insulated if they are exposed to extremely cold weather or blizzards. If the tubes are not insulated, they must have a diameter of at least $\text{Ø}32$ mm.
- The drain tube must have a minimum tilt of 2.5° downstream of the boiler.
- For tubes with $\text{Ø}21.5$ mm, the maximum permitted length is 3 metres.
- If the appliance is installed in a non-heated premises, the tube system must be treated as if it was an outdoor installation.
- To prevent the risk of tripping, the outdoor tubes must be fixed to the walls.

Before connecting the condensate drain, choose one of the following disposal options:

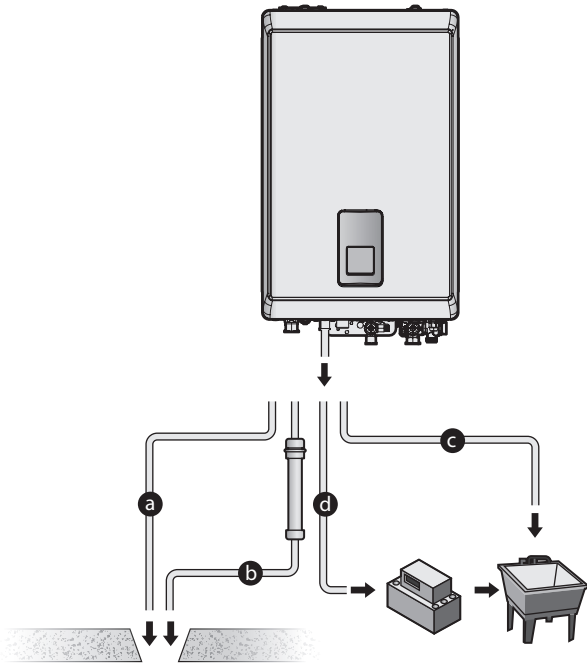

- a. From the boiler directly into an external drain.
- b. From the boiler, through a neutralizing agent, and then into an external drain.

Note If you choose this option, the neutralizing agent must be replaced periodically. Depletion of the neutralising agent will vary, based on the usage rate of the boiler. During the first year of operation, the neutraliser should be checked every few months for depletion and replaced as needed.

- c. From the boiler into a laundry tub.

Note The bottom of the boiler must be higher than the top of the laundry tub to use this option. The condensate line must have a negative slope to drain properly.

- d. From the boiler into a condensate pump, and then into a laundry tub.

Note A pump can be used when there is a long distance between the boiler and the laundry tub or when the bottom of the boiler is lower than the top of the laundry tub.

To connect the condensate drain:

1. Connect a drain line to the condensate trap. The condensate trap outlet will allow 21.5 mm. Use only corrosion-resistant material for the drain line, such as PVC or CPVC. Do not reduce the size of the drain line to less than 21.5 mm. The drain line can be connected to the condensate trap using a condensate trap hose. The hose connection must be secured with a hose clip.

Note This hose is supplied along with the boiler.

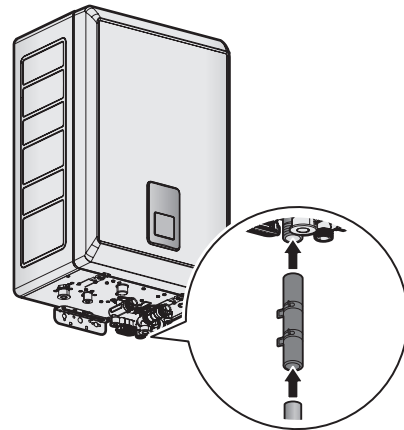

2. Place the free end of the drain line into an appropriate drain.
3. If you are using a condensate pump, ensure that the pump allows for up to 3.78 LPH of drainage for each boiler in the system.
4. If you are not using a condensate pump, ensure that the drain line is pitched downward at a minimum slope of 6 mm per 30 cm.

Note Water must be poured into the exhaust connection to fill the condensate trap.

4.4 Pipe Dimensions and Water Pressure

The requirements recommended for the pipe dimensions and water pressure are as follows:

- The connection diameter for the domestic cold water inlet must be at least Ø15 mm.
- If a shut-off valve is fitted at the domestic cold water inlet, it must have a safety valve incorporated, calibrated to 9 bar.
- For DHW production installation, the inlet pressure must be over 0.5 bar.
- For hot water supply to the second floor of a building, the minimum pressure required is 1.0 bar.
- The pipe diameter is not determined by the boiler connection but must be calculated in accordance with its length and consequent pressure drop.

4.5 Pressure Relief Valve

The requirements recommended for the pressure relief valve are as follows:

- The pressure relief valve is calibrated to be activated at a maximum pressure of 3 bar, and all the pipes and connections must therefore be able to withstand pressures of up to 3 bar.
- Connect the pressure relief valve drain to a tube with a diameter of at least Ø15 mm. It must tilt in a downstream direction throughout its entire length, and the water must run off to a suitable drain. It must be positioned so as not to cause damage to cabling, electrical equipment or persons.
- The drain must not be located above a window, entry door or any other public access point. Bear in mind that boiling water or steam could come out when draining.

4.6 Filling the System

Before filling the boiler pipes, pull up the air flue cap to allow the pipes to fill properly. Press the cap back in when the pipes are full.

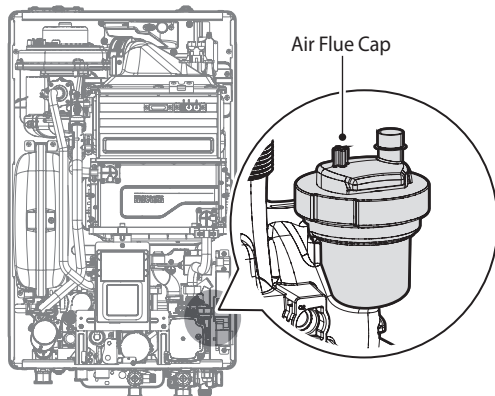

- Note**
- Ensure that the flue cap is fitted before testing or operating the system.
 - To perform an air purge after initially filling the boiler pipes, the pump will run for 5 minutes and 20 seconds. The boiler will operate normally after performing an air purge.

4.7 Testing the Water System

WARNING

Ensure that the boiler is full of water before firing the burner. Operating the unit without filling it will damage the boiler. Such damage is not covered by the warranty, and may result in property damage or severe personal injury.

Perform a fill test after installing the boiler's water system to make sure that the system has been installed properly. Follow the instructions below to perform a fill test on the water system.

1. Close the manual air flues and the boiler drain valve.
2. Fill the boiler. The correct pressure will vary with each application.
3. If the pressure is lower than the minimum pressure set (1 bar by default), error code E02 will appear on the display.
4. Fill the boiler with more water until the error message disappears.
5. At initial fill and during boiler start-up and testing, check the system thoroughly for leaks. Repair any leaks before proceeding further.

WARNING

Eliminate all system leaks. The continual introduction of fresh makeup water will reduce boiler life. Minerals can build up in the heat exchanger, reducing heat transfer, overheating the heat exchanger and causing heat exchanger failure.

CAUTION

Before operating the boiler for the first time, ensure that the boiler system is filled with water. Purge the air inside the system to avoid damage to the boiler.

5. Connecting the Gas Supply

WARNING

- If a gas type other than the one specified on the boiler reference plate is used, it could cause a fire or even an explosion.
- It is important to ensure that the gas supply is suitable for the type and capacity of the boiler.
- Thoroughly check the seal and draining of the entire installation, as a gas leak could cause serious damage.

DANGER

- Gas leaks can cause explosions resulting in serious personal and material damage.
- Keep all doors and windows open while you are bleeding the gas pipes and put out any cigarettes, flames or other possible source of ignition.

For the installation of any type of gas, the installer must be authorised by the Ministry of Industry and strictly follow the applicable Gas Regulations. The gas installation must comply with the Gas Installation Regulation.

However, the following recommendations must be complied with, at the least:

- Before installing the gas pipes, check the type of gas is compatible with the boiler.
- Check that the gas meter in the home can measure the rate of gas supply required.
- The gas pipe diameter is not determined by the boiler connection. It should be calculated in accordance with its length and consequently its pressure drop.
- The pipes must be directly connected to the main gas supply pipe, not connected in parallel to other gas appliances.
- Check there are no leaks from the installation.
- The gas supply company is solely responsible for connecting the gas meter to the gas installation.

To connect the gas supply:

1. Connect the gas supply pipe to the connection located on the underside of the appliance.
2. After completing the gas installation, check there are no leaks and bleed the air from all the pipes, following the procedures described in the applicable standards to this respect.

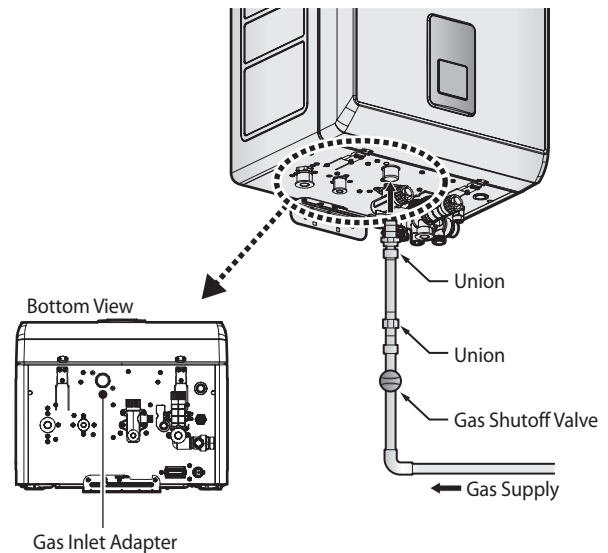

5.1 Gas Pipe Material

WARNING

The boiler must be left running for 10 minutes before checking the gas pressure, to obtain thermal equilibrium.

The gas installation pipes must be made of suitable materials and comply with the applicable legislation to this respect.

The gas connection must be made using a rigid pipe, inserting a shut-off valve between the boiler and the pressure regulator.

All the pipes must be suitably fixed in place.

5.2 Propane Gas Installations (LPG)

DANGER

- Thoroughly check the seal and the drainage of the entire installation, as a gas leak could cause serious damage.
- If a propane-fired boiler is installed in an interior room or compartment underground, one side of the building must be open to the exterior.
- If a gas tank is used, it must be installed in a cool, shaded place away from direct sunlight. It must also be thoroughly secured to prevent it from tipping over, which could cause an explosion.

If the boiler is used with propane, a gas regulator suitable for this type of gas must be installed. The connection and installation must be made in accordance with the applicable regulations and standards at the time of installation.

Note The output pressure of the pressure regulator must be in accordance with Standard EN 437.

5.3 Measuring the Inlet Gas Pressure

WARNING

The boiler cannot function properly without sufficient inlet gas pressure. Measuring the inlet gas pressure should be performed by a licensed professional only.

The inlet gas pressure must be maintained between 17 mbar and 25 mbar for natural gas and between 25 mbar and 35 mbar for liquefied propane.

To measure the inlet gas pressure:

1. Shut off the manual gas valve on the gas supply line.

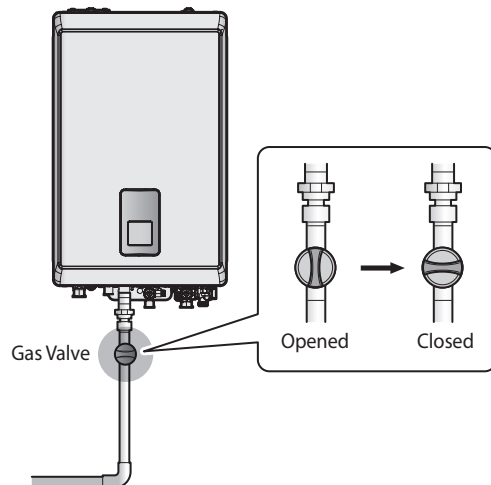

2. Open a hot water faucet. The boiler should turn on and the gas in the gas supply line will be purged.

3. Leave the faucet on until the boiler shuts down due to a lack of gas supply, and then turn off the hot water faucet.
4. Unfasten the 2 latches (at the top) and remove 2 screws (at the bottom) to remove the front cover and gain access to the internal components.

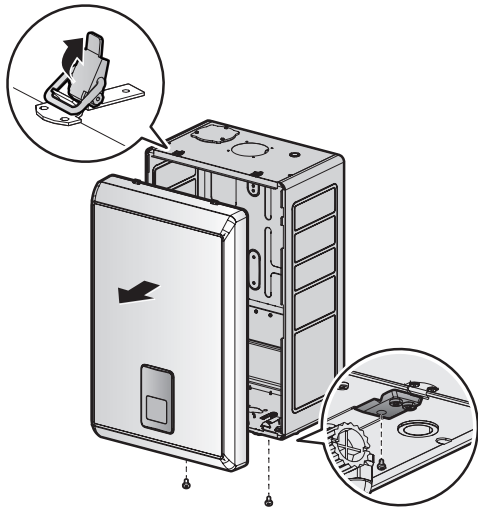

! CAUTION

Ensure that no cables are in the way before folding down the PCB assembly. If the assembly is stuck, do not force it. Doing so may damage the cables and result in serious malfunctions. Check again to ensure that no cables or any other parts are in the way before you proceed.

5. Loosen the screws indicated in the figure below and connect a manometer to the pressure port. Reset the manometer to zero before use.

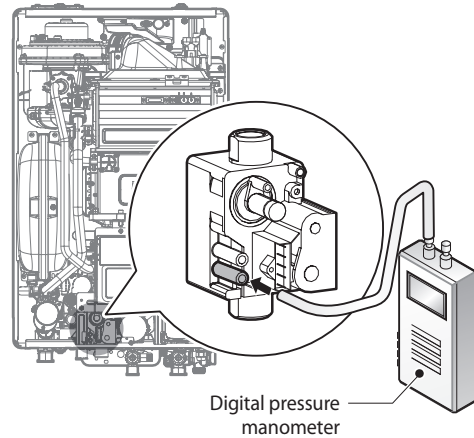

6. Re-open the manual gas valve and check for leaks.
7. Open multiple fixtures that have high flow rates, such as bathtub and shower faucets, to ramp the boiler up to its maximum firing rate.
8. When the boiler reaches its maximum firing rate, check the inlet gas pressure reading on the manometer. The gas pressure must fall within the ranges specified on page 8.

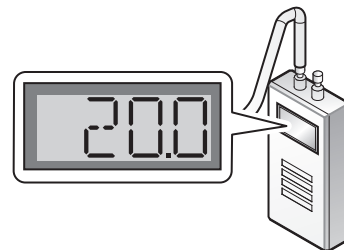

6. Flue System

WARNING

Improper flue of the boiler can result in excessive levels of carbon monoxide, which can lead to severe personal injury. Flue should be performed only by a licensed professional.

No specific ventilation is required in the room the boiler is installed in. If it is installed in a cupboard or compartment, no specific ventilation is required, providing the aforementioned dimensions are observed. The requirements and recommendations stipulated in the Regulation for Heating Installations in Buildings (RITE) and any other applicable legislation in this field must be observed.

6.1 Flue Terminal Positions

CAUTION

- The terminal must be fitted with suitable protection if it is less than 2 m from a balcony, on a flat roof or surface that could be accessed by people.
- The wall that the gas removal and air intake ducts are fixed to must not be made of combustible or flammable materials. The wall that the end of the duct passes through must lead to the outside of the home. There must be no hazardous materials or obstructions near the duct.
- If the outlet passes through a wall made of combustible material the end terminal must be covered with at least 20 mm of incombustible material and must maintain a distance of at least 50 mm from any flammable material.
- The parts connecting the flue outlet must be correctly joined using sealing gaskets. Ensure that there are no leaks from any part of the removal circuit.
- Switch off the boiler and wait for the pipes to cool down before cleaning the gas removal and air intake ducts.
- The gas removal and air intake ducts must be protected from snow accumulation.

The installation of the flue exhaust and combustion air intake system must be calculated and made by sufficiently qualified and authorised staff. On designing and mounting the installation, all national and local regulations, standards and stipulations applicable at the time of installation must be taken into account.

The minimum distances between the flue exhaust terminal and the building elements must comply with those shown in the following table:

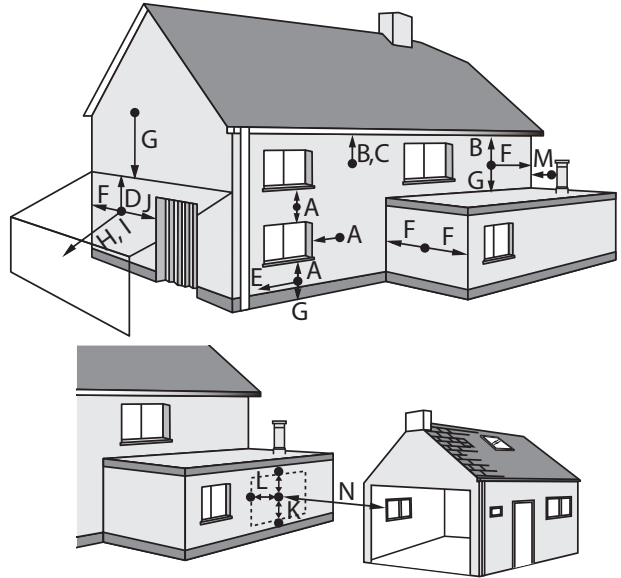

Terminal Position		Minimum Distance (mm)
A	From openings (e.g. doors, windows, ventilation grilles)	300
B	Under a cornice	200
C	Under a gutter or drainpipes	75
D	Under a balcony or car port roof	200
E	From vertical drainpipes	150
F	From internal and external corners of the building	300
G	From the ground, roof and balconies	300
H	When no other outlet is installed	600
I	From the wall with the pipe to the front wall	1200
J	From openings (e.g. doors, windows) under the roof	1200
K	Vertically from a flue	1500
L	Horizontally from a flue	300
M	Vertical flue clearance (Non combustible building material)	500
N	From a front surface with openings	2000

- Note**
- For vertical ducts, the outlet must be at least 60 cm from any opening.
 - The dimensions (B, C, D, and E) may be reduced to 25 mm, as long as the flue terminal is extended to clear any overhangs.

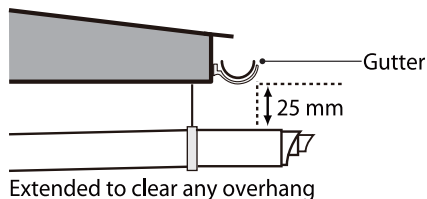

6.2 Selecting a Flue System

WARNING

- The gas removal ducts must not be in contact with or near flammable materials and they must not pass through any structures or walls of buildings made of such materials.
- If you replace the boiler, the old gas removal system must be replaced by a new one.
- The standard flue must be installed level. If flue extensions are needed, they must have a 3 degree fall back to the appliance.

The fume extraction connection depends on the type of system chosen (coaxial removal system or dual duct removal system). Carefully follow the instructions given below:

Coaxial System

For coaxial system, fit the components as shown in the figure:

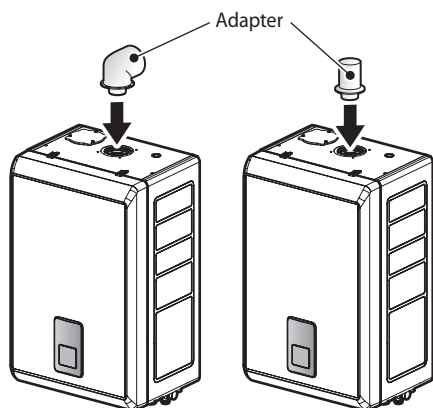

Dual Duct System

For dual duct system, fit the components as shown in the figure:

1. Remove the air intake cap.

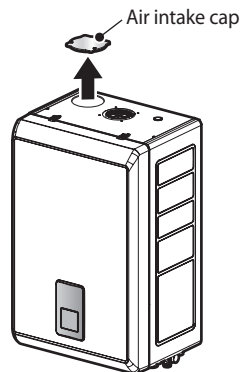

2. Connect the corresponding adapters to the boiler (the gas removal and air intake adapters).

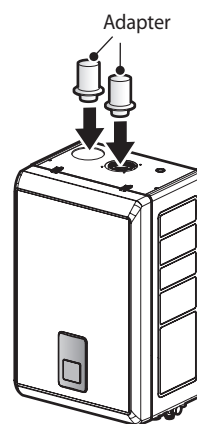

3. Connect the gas removal and intake ducts.

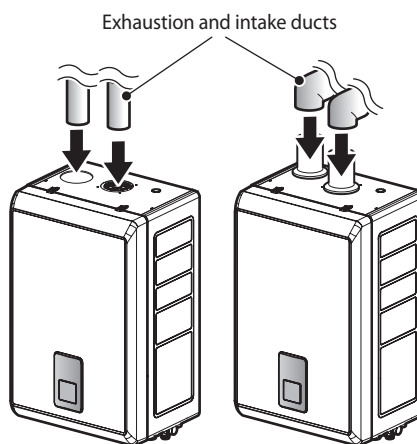

6.3 Coaxial Systems

6.3.1 Horizontal Coaxial Removal (Type C₁₃)

Standard Removal System

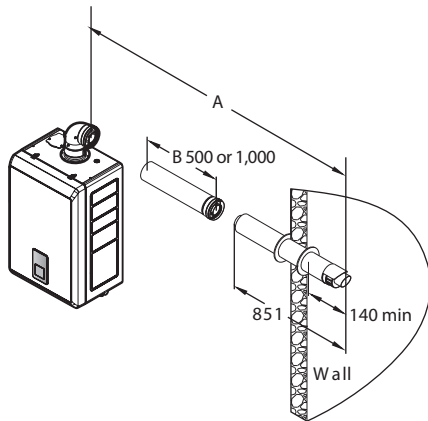

Ø60/100 => Max. length: A=20 m

Ø80/125 => Max. length: A=68 m

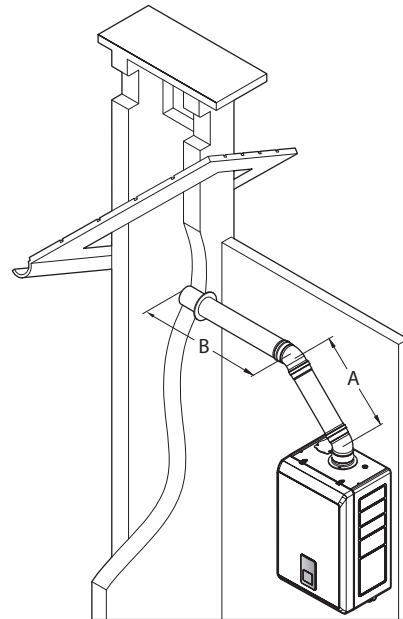

Ø60/100 => Max. length: A+B-(1 x 45°elbow) = 20-1 = 19 m

Ø80/125 => Max. length: A+B-(1 x 45°elbow) = 68-1 = 67 m

Extended Removal System

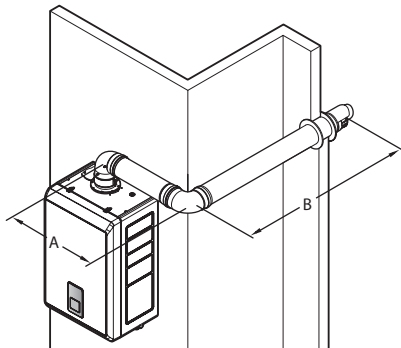

Ø60/100 => Max. length: A+B-(1 x 90°elbow) = 20-1.3 = 18.7 m

Ø80/125 => Max. length: A+B-(1 x 90°elbow) = 68-2.2 = 65.8 m

Pipe Diameter (mm)	Maximum Length (m)	Elbow	Equivalent Length (m)
Ø60/100	20	45°	1.0
		90°	1.3
Ø80/125	68	45°	1.0
		90°	2.2

6.3.2 Vertical Coaxial Removal (Type C₃₃)

Standard Removal System

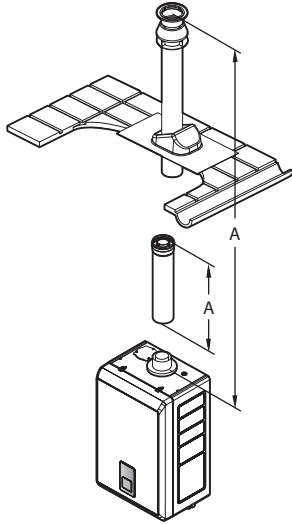

Ø60/100 => Max. length: A=21 m
 Ø80/125 => Max. length: A=70 m

Extended Removal System

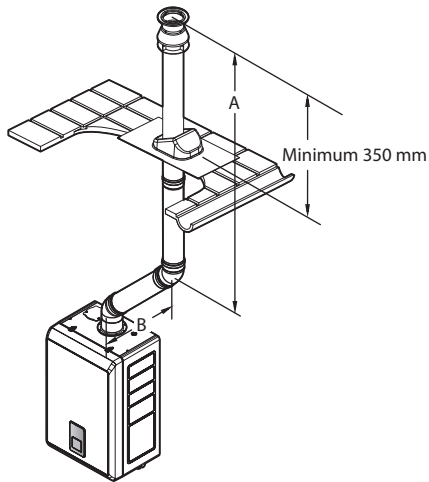

Ø60/100 => Max. length: A+B-(1 x 45°elbow) = 21-1 = 20 m
 Ø80/125 => Max. length: A+B-(1 x 45°elbow) = 70-1 = 69 m

Pipe Diameter (mm)	Maximum Length (m)	Elbow	Equivalent Length (m)
Ø60/100	21	45°	1.0
Ø80/125	70		

6.4 Dual Duct Systems

6.4.1 Horizontal Dual Duct Removal (Type C₅₃)

Standard Removal System

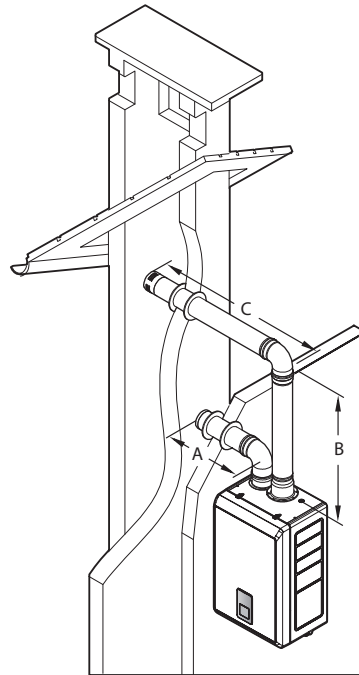

Ø80/80 => Max. length: A+B+C-(1 x 90°elbow) = 110-2.2 = 107.8 m

Extended Removal System

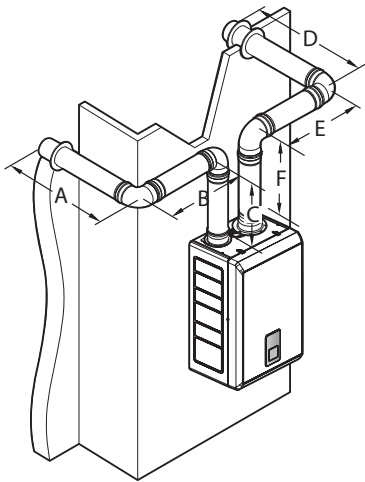

Ø80/80 => Max. length: $A+B+C+D+E+F-(4 \times 90^\circ \text{elbow}) = 110-(4 \times 2.2) = 101.2 \text{ m}$

Pipe Diameter (mm)	Maximum Length (m)	Elbow	Equivalent Length (m)
Ø80/80	110	90°	2.2

6.4.2 Vertical Dual Duct Removal (Type C₈₃)

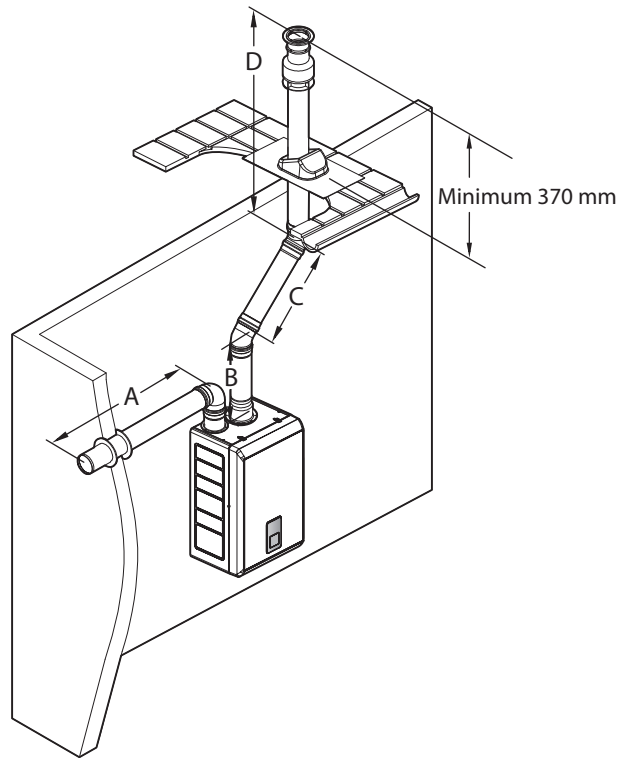

Ø80/80 => Max. length: $A+B+C+D-(2 \times 45^\circ \text{elbow}) = 110-(2 \times 1.4) = 107.2 \text{ m}$

Pipe Diameter (mm)	Maximum Length (m)	Elbow	Equivalent Length (m)
Ø80/80	110	45°	1.4

6.5 Measuring Flue Length

The gas removal and air intake systems may be oriented in any direction (north, south, east or west). Some special components such as elbows are used to help reach certain positions. Each removal terminal kit includes an adapter for connection to the boiler and a removal terminal.

The total length of the tubes must not exceed the maximum value defined. If the removal installation includes elbows while calculating the total length you must take into account that each elbow has a resistance equal to a specific linear Leq equivalent length (see table).

There are two different types of terminals (horizontal and vertical), for both the coaxial removal system and the dual duct removal system.

Carefully study the diagrams representing the different types of removal and select the one that best suits the conditions of your installation. To choose the removal accessories required for each installation, see the list of accessories on the NAVIEN price list.

Maximum Total Length

Type	Pipe Diameter (mm)	Orientation	Maximum Length (m)
Coaxial	Ø60/100	Horizontal	20
		Vertical	21
	Ø80/125	Horizontal	68
		Vertical	70
Dual Duct	Ø80/80	Horizontal	110
		Vertical	

Equivalent Length of Elbows and Adapters

Type	Pipe Diameter (mm)	Elbow	Equivalent Length (m)
Coaxial	Adapter Ø60/100 -> Ø80/125	-	0.5
		Ø60/100	45°
	90°		1.3
	Ø80/125	45°	1.0
		90°	2.2
	Dual Duct	Ø80/80	45°
90°			2.2

6.6 Terminating the Flue

Before installing the boiler, determine what type of flue termination is appropriate for the installation location and situation. The subsections that follow describe some typical flue configurations.

CAUTION

Minimum Clearance to Metering devices and Relief equipment. Maintain a minimum horizontal clearance of 1.22 m from electric meters, gas meters, regulators, and relief equipment. Do not install the boiler above or below electric meters, gas meters, regulators, or relief equipment unless a 1.22 m horizontal clearance is maintained.

7. Setting the DIP Switches

CAUTION

Do not remove the front cover unless the power to the boiler is turned off or disconnected. Failure to do so may result in electric shock.

The boiler has 2 sets of DIP switches on the main circuit board (PCB) and 2 sets of DIP switches on the front panel. DIP switches are used to control the functionality of the boiler. Set the DIP switches appropriately, based on the installation environment.

7.1 PCB DIP Switches

Dip Switch (Set of 8)

The DIP SW 1 on the circuit board configures boiler type, capacity, burner type, country, and discharge of condensate function.

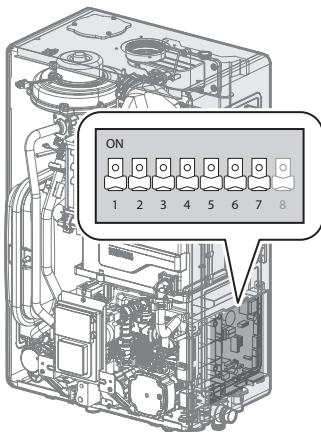

DIP SW1

Switch	Function	Setting	
1	Boiler Type	SOLO	ON
		COMBI	OFF
2	Reserve		
3&4	Capacity	42kw	3-OFF, 4-ON
		54kw	3-ON, 4-ON
5&6	Country	UK	5-OFF, 6-OFF
		Not Used	5-ON, 6-OFF
		Not Used	5-OFF, 6-ON
		Not Used	5-ON, 6-ON
7&8	Boiler Model	NCB700-UK	7-OFF, 8-ON

DIP SW2

Switch	Function	Setting	
1	Reserve		
3	Reserve		
4	Reserve		
5&6	Country		

7.2 Front Panel DIP Switches

Dip Switch (Set of 2)

The DIP SW on the front panel configures the fuel selection.

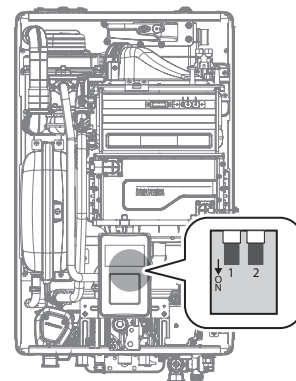

Switch	Function	Setting	
1 & 2	Fuel selection	LNG(G20)	1-OFF, 2-OFF
		Not Used	1-OFF, 2-ON
		LPG(G30)	1-ON, 2-OFF
		LPG(G31)	1-ON, 2-ON

8. Connecting Electrical Supplies

WARNING

Improperly connecting the electrical supplies can result in electrical shock and electrocution. Follow all applicable electrical codes of the local authority having jurisdiction. Connecting the electrical components should be performed only by a licensed professional.

DANGER

- You must ensure that the boiler is disconnected from the electrical supply before carrying out any servicing inside the boiler and, particularly, on the electric terminal strips.
- If the electrical supply is connected electrical contact could occur, causing serious damage due to electrocution.

CAUTION

Label all wires before disconnecting them when you work on the controls. Wiring errors can cause improper and dangerous operation. Verify proper operation after servicing.

The boiler electrical connections must be made by sufficiently qualified staff in strict compliance with the sections below and with any electrical safety regulations applicable at the time of installation.

Note The NCB700 boiler has an electrical protection degree of IPX5D. The electrical connection must be made via a bipolar switch located on the same premises as the boiler. The switch must have a minimum pole separation of 3 mm.

8.1 Accessing the Terminal Strips

To access the PCB where the terminal strips are located, carefully follow the steps below:

1. Turn off the power supply to the boiler.

2. Unfasten the 2 latches (at the top) and remove 2 screws (at the bottom) to remove the front cover and gain access to the internal components.

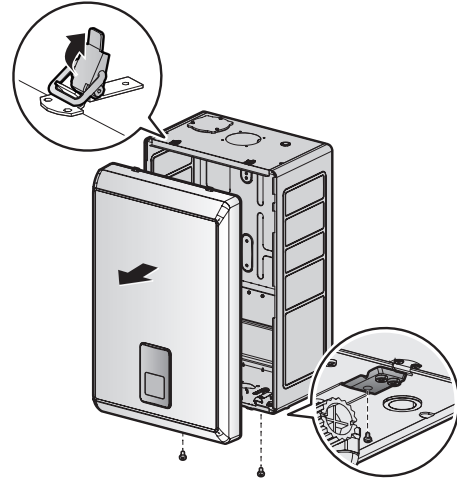

Note

- Before connecting the cables to the corresponding connector terminals, it is essential to thread them through the cable glands located on the underside of the boiler.
- While threading the cables and making the connections, take special care that no pieces of cable fall onto the electrical connections or electronic cards.
- Make sure you have tightened the cables sufficiently. It is essential for the boiler to be grounded.

3. Remove the screw and pull the cover downwards before connecting the power supply, room thermostat, OpenTherm, and the outdoor temperature sensor.

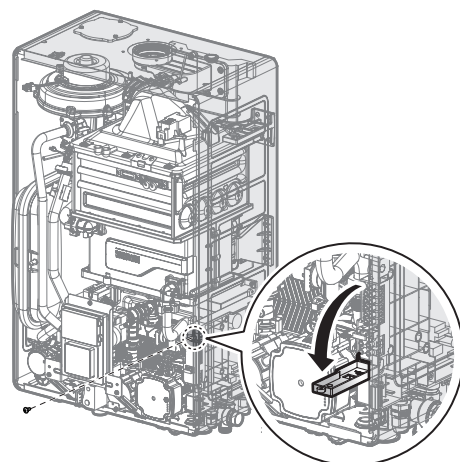

8.2 Connecting the Power Supply Cables

To correctly establish the boiler's electrical connection, follow the indications given in the figure and the indications on the identification label for the terminal strip connections.

DANGER

Disconnect the main electrical supply before beginning any work and make sure all the necessary safety precautions are taken into account.

1. Remove the cap "A" from the cable gland on the underside of the boiler.

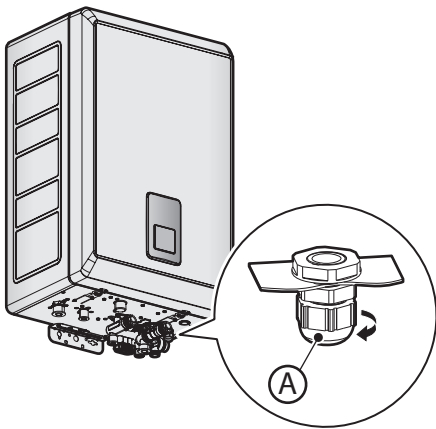

2. Remove the black silicon seal "B" from the cable gland and thread it onto cable "C".

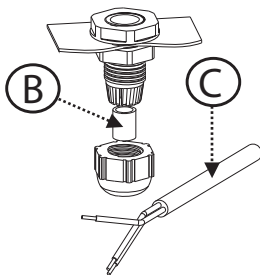

3. Insert cable "C" into the lid "A" together with the seal "B".

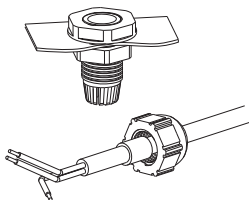

4. Insert all these elements in the cable gland and press on the lid "A" until the cable is sufficiently fixed in place and the unit is sealed.

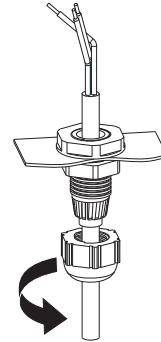

- Note** The boiler must be connected to the supply terminals, which are clearly indicated on the left side of the PCB, via the cable supplied with the boiler for this purpose.

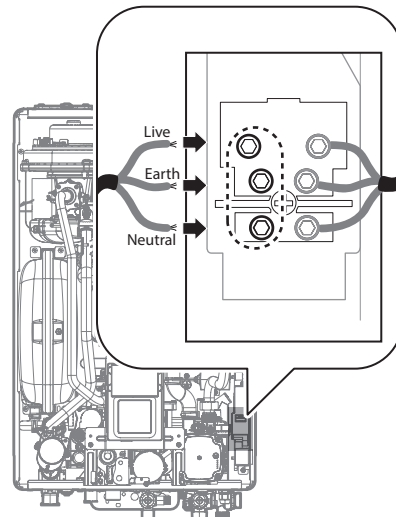

- Note**
- Fuse Size: 5 mm x 20 mm
 - Fuse Rating: 250 V, 3.15 A

DANGER

This appliance must be earthed. Electrocutation caused by touching live parts can be fatal. Before working on the appliance, turn off the power supply and secure against restart.

- Note** The boiler must be earthed. Connection of the whole electrical system of the boiler, including any heating controls to the electrical supply must be through one common isolator and must be fused 3.15 A maximum.

8.3 Connecting the Switched Live

The boiler is designed to be connected to a switched live. The switched live cables are to be connected to terminals 5 (Switched Live In) and 6 (AC Live) of the boiler terminal strip.

8.4 Connecting the Room Stat or OpenTherm

The boiler is designed to be connected to a Room Stat or OpenTherm. The Room Stat or OpenTherm cables are to be connected to terminals 3 and 4 of the boiler terminal strip.

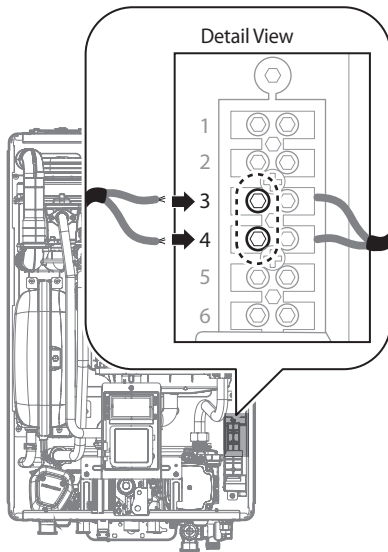

8.5 Connecting the Outdoor Temperature Sensor

The boiler is designed to be able to function with an outdoor temperature sensor. The sensor cables are to be connected to terminals 1 and 2 of the boiler terminal strip.

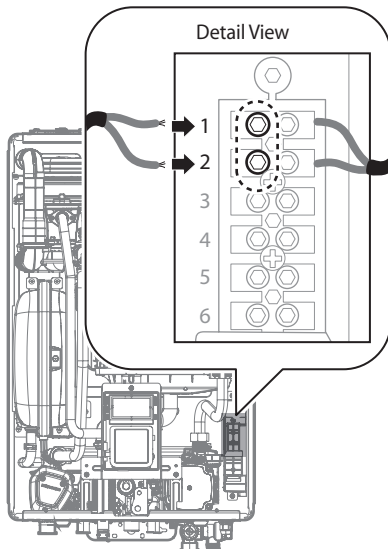

8.6 OpenTherm® Protocol

OpenTherm® is an industry standard modulating control available from several control manufacturers and the NCB700 boiler has an OpenTherm® interface. This enables our modulating range of OpenTherm® room controls to be connected without any further modifications.

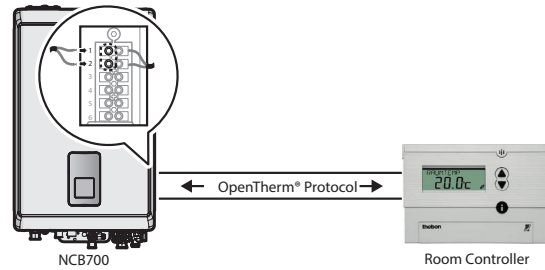

8.7 Connecting the Navien Smart Room Controller (Optional)

Instead of using your boiler with a generic room thermostat, you can connect the Navien Smart Room Controller (NR-35D) to the boiler and benefit from various additional features and more efficient control of the heating system using a mobile device.

As the Navien NCB700 boiler has a dedicated connector for the Navien Smart Room Controller on the back of the front panel, terminal connection at the terminal block is not required. Simply connect the Navien Smart Room Controller cable to the 2-pin connector.

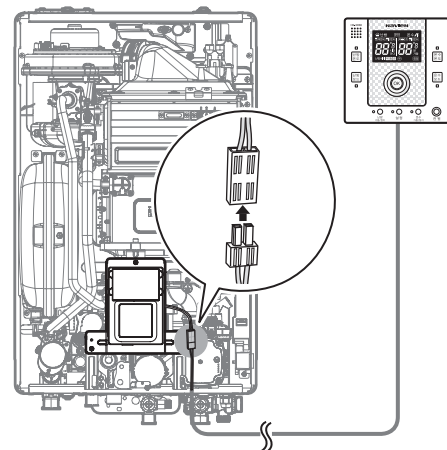

Note

- You need to install an app on your mobile device to control the boiler from your mobile device.
- Refer to the instruction manual that is provided with the Navien Smart Room Controller about the additional features available with the controller.

9. Installation Check list

After installing the boiler, review the following checklist. Complete the boiler start-up process by carrying out the checks listed in the table below.

If you have additional questions or need assistance with installation, contact an official Technical Assistance Service (TAS), or refer to the technical support section of Navien's website (www.navien.co.uk).

Check	Value measured	Notes
Check that the boiler is filled with water and check for any leaks in the heating installation.		
Check the gas type. If the reference label is changed on gas type changeover, check the gas inlet pressure.		
Check that the gas circuit is hermetically sealed.		
Check that the control panel is working correctly. <ul style="list-style-type: none">• Check that it functions normally when the boiler is switched on.• Check that the heating system water pressure is correct.• Check that the heating temperature indicated is correct.• Check that the DHW temperature indicated is correct.• Check that the reset operation is performed correctly.• Check that the parameters on the technical menu are correctly adjusted.		
Measure the CO ₂ values.		
Check that the boiler works correctly with the outdoor temperature sensor, if it has a sensor connected.		
Check that the anti-frost function is working correctly.		
Check that the condensate drain pump is working, if the boiler has one.		

10. Operating the Boiler

10.1 Using the Front Panel

The front panel allows you to adjust the temperature and view the operating status or error codes. Remove the protective sheet from the front panel before using it.

10.1.1 Icons and Digital Display

The icons and digital display on the front panel provide important information required for the boiler's operation. Refer to the following table for detailed information.

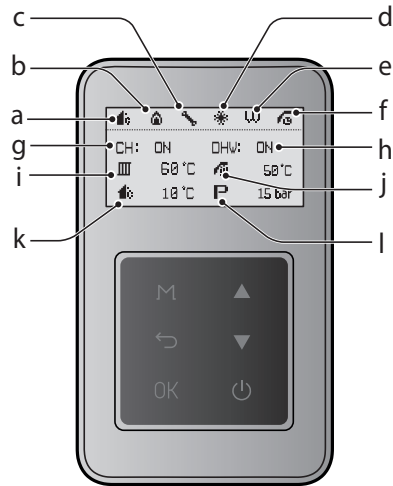

a		Outdoor temperature compensation (OTC) Displayed when the outdoor temperature compensation (OTC) is enabled.	b		Combustion Displayed when the burner is combusting.
c		System fault Displayed when a system fault is detected.	d		Anti-freeze Displayed when the boiler is operating in anti-freeze mode.
e		Schedule programming mode Displayed when the boiler's schedule programming operation is set.	f		DHW preheat Displayed when the DHW preheat feature is enabled. <ul style="list-style-type: none"> DHW preheat DHW Intelligent DHW preheat (Always on) DHW preheat (Weekly) DHW preheat off (Eco mode)
g		Central heating demand Indicates the central heating demand is present.	h		DHW demand Indicates that DHW demand is present.
i		Central heating set temperature When the central heating temperature is set: Displays the currently set central heating temperature. When the central heating temperature is not set: Displays the current supply water temperature.	j		DHW set temperature When the DHW temperature is set: Displays the currently set DHW temperature. When the DHW temperature is not set: Displays the current supply water temperature when using the DHW thermostat. Displays the current DHW tank temperature when using the DHW sensor.
k		Outdoor temperature Displays the outdoor temperature.	l		System pressure Displays the internal water pressure of the boiler system.

10.1.2 Buttons

Using the buttons on the front panel, you can turn on or off the boiler, monitor the current operation status, and set the values required for the boiler's operation, such as central heating and DHW supply temperatures. Refer to the following table for detailed information.

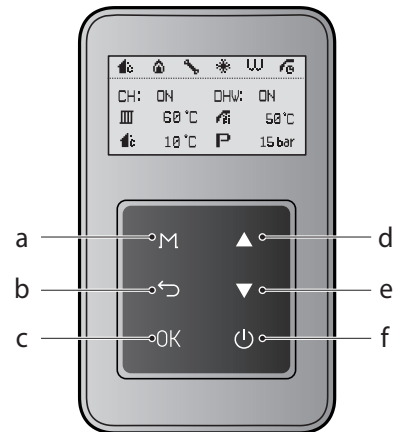

a		Menu button Access to the Main menu screen.	b		Back button Access to the previous screen.
c		OK button Access to the selected item.	d		Up button Increases the temperature setting, parameter or moves up.
e		Down button Decreases the temperature setting, parameter or moves down.	f		Power button Turns the boiler on or off.

10.2 Turning the Boiler On or Off

To turn the boiler on or off, press the Power button (⏻).

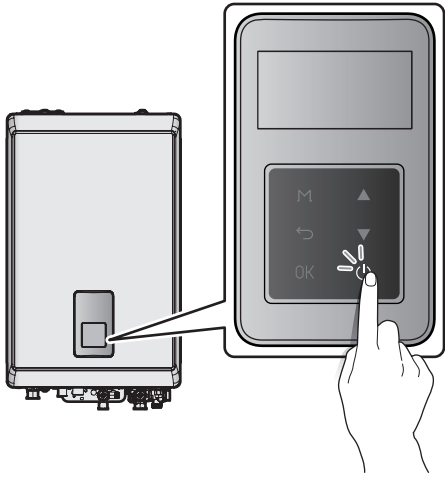

When the power is turned on for the first time, you must complete the start-up wizard. The temperature will appear on the front panel display after the power is turned on.

10.3 Start-Up Wizard

The setup wizard should run the first time the unit is powered on. The wizard must be completed before the boiler can be used.

1. Set the time.
 - YYYY:MM:HH:MM:SS
2. Check the gas type.
 - LNG (G20)
 - LNG (G25_G27) (not available)
 - LPG (G30)
 - LPG (G31)
3. Select the Heat Demand.
 - Navien Thermostat
 - OpenTherm
 - CH Thermostat
 - Switched Live
4. Once the Setup Wizard is finished, a summary of the settings will be displayed. Press the OK button (OK) at each summary screen until the main screen is displayed. Settings made in the Setup Wizard can be adjusted from the Main Menu and Installer Menu as described in Section 10.6 and 10.7.

10.4 Adjusting the Temperature

10.4.1 Adjusting the Central Heating Temperature

To adjust the central heating temperature:

1. In normal operation mode, press the Down button (▼). The central heating temperature (CH) is highlighted on the screen.

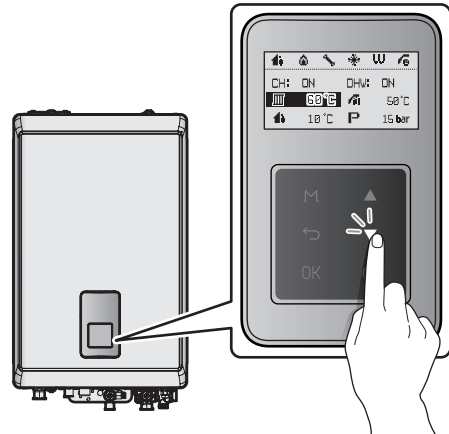

2. Press the OK button (OK) to select the central heating temperature (CH). The highlighted section will flash.

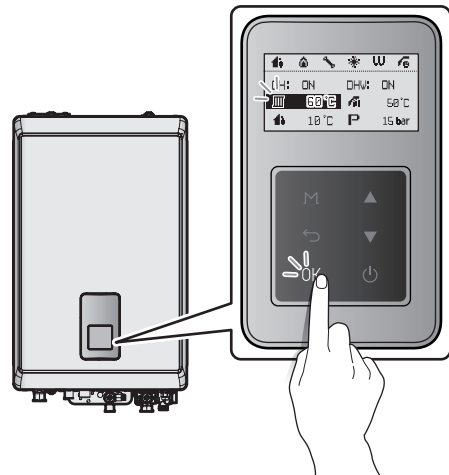

3. Press the Up button (▲) or the Down button (▼) until the desired temperature appears on the display. You can adjust the temperature while the display is flashing. Once the display stops flashing, the temperature setting is stored.

Note

- Take note of the original heating temperature in case you want to restore it to the default.
- The default central heating supply water temperature range is 40°C (Absolute MIN) to 85°C (Absolute MAX).
- The default central heating return water temperature range is 30°C (Absolute MIN) to 65°C (Absolute MAX).
- The central heating temperature cannot be adjusted when the Outdoor Reset Control is used.
- The central heating temperature cannot be adjusted, when the Heat Demand function is set to OpenTherm.

10.4.2 Adjusting the DHW Temperature



WARNING

Before adjusting the water temperature, carefully read “To prevent burns:” on page 5. Water above 52°C can cause instant scalding or severe burns.

To adjust the water temperature:

1. Make sure that all hot water taps are closed, and ensure that the internal circulator and any external circulating pumps are off.
2. In normal operation mode, press the Up button (▲) The DHW temperature (🔥) is highlighted on the screen.

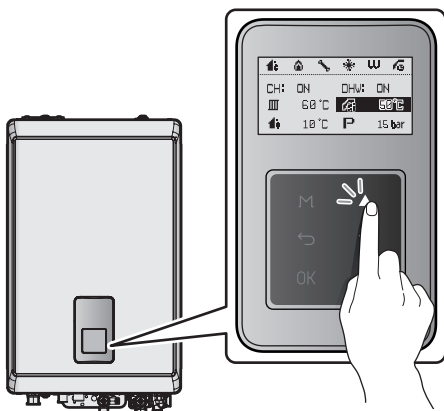

3. Press the OK button (OK) to select the DHW temperature (🔥). The highlighted section will flash.

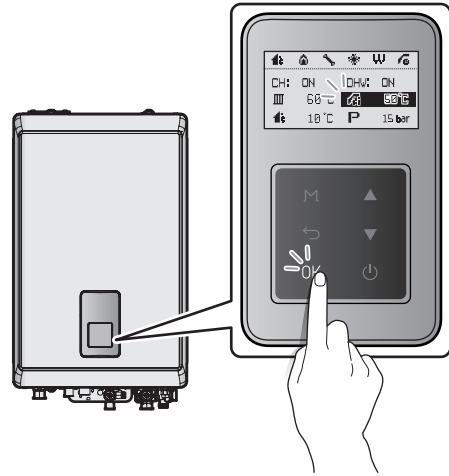

4. Press the Up button (▲) or the Down button (▼) until the desired temperature appears on the display. You can adjust the temperature while the display is flashing. Once the display stops flashing, the temperature setting is stored.

Note

- Take note of the original water temperature in case you want to restore it to the default.
- The default DHW temperature range is 30°C to 65°C.
- The boiler will retain your settings during a power outage.
- The DHW temperature cannot be adjusted, when the Heat Demand function is set to OpenTherm.

10.5 Resetting the Boiler

If an error message appears, you can try resetting the boiler to resolve the problem. To reset the boiler, press the Back button (←).

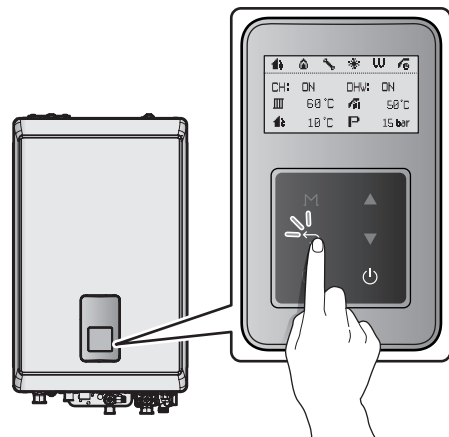

If resetting the boiler does not solve the problem, refer to the Troubleshooting section of this manual or contact a Technical Assistance Service.

10.6 Accessing Basic Menu Items

In the Main Menu screen, you can view the boiler's operating conditions, configure the central heating and DHW temperatures, and review error history. Press the Menu button (M) to enter the Main Menu screen.

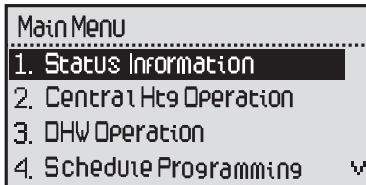

10.6.1 Viewing Basic Information

To view information about the boiler, press the Menu button (M), and then select "1. Status Information".

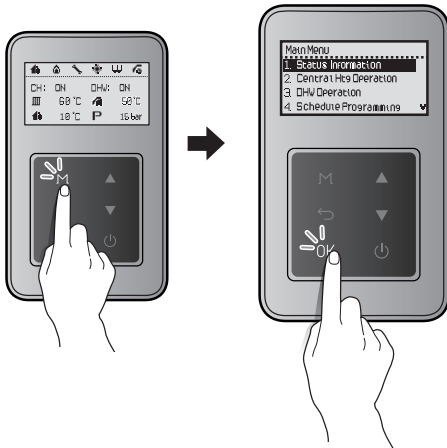

Item	Description
8. Inlet Temp	Inlet temperature (°C)
9. DHW Temp	DHW temperature (°C)
10. Water Flow	Water flow rate (LPM)
11. Water Press	Water pressure (bar)
12. Flame Value	Flame detector AD value <ul style="list-style-type: none"> • Flame On: 8bit AD values equal to or lower than 70 • Flame Off: 8bit AD values equal to or higher than 175
13. Fan Target RPM	Fan target speed (RPM)
14. Fan Current RPM	Fan speed (RPM)
15. Fan Target APS	Fan target speed (APS)
16. Fan Current APS	Fan speed (APS)
17. Exhaust Temp	Exhaust temperature (°C)
18. OTC ON/OFF	OTC status (Enabled/Disable)
19. K-Factor Set Value	K-Factor set value
20. Model	Model type
21. Type	Boiler type (Combi/System)
22. Gas	Fuel Type (LNG G20/LPG G30/LPG G31)
23. Main F/W Ver	Main firmware version
24. Panel F/W Ver	Panel firmware version

Note The fan motor controls the APS, so the fan target speed (Fan Target RPM) is only for your reference.

Press the Up button (▲) or the Down button (▼) to switch between the information items. Press the OK button (OK) to select an item and view the information.

Press the Back button (←) to exit information view mode.

Item	Description
1. Operation State	Current Operation State
2. Heat Capacity	Heat capacity (%)
3. CH Set Temp	Central heating set temperature (°C)
4. DHW Set Temp	DHW set temperature (°C)
5. Supply Temp	Heating supply temperature (°C)
6. Return Temp	Boiler return temperature (°C)
7. Outdoor Temp	Outdoor temperature (°C)

10.6.2 Setting the Central Heating Operation

To set the boiler's central heating operation, press the Menu button (M), and then select "2. Central Htg Operation".

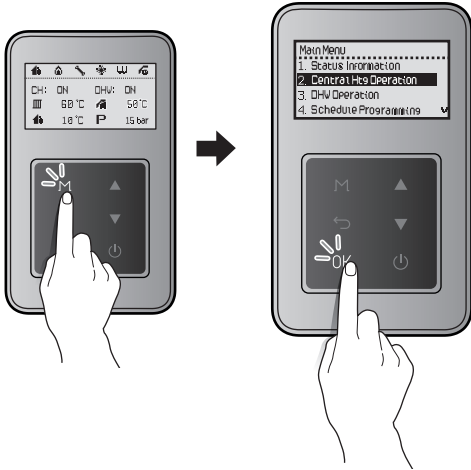

Press the Up button (▲) or the Down button (▼) to switch between the list items or to increase/decrease setting values. Press the OK button (OK) to select an item or to confirm after making changes.

Press the Back button (↶) to return to the previous screen or menu.

Item	Description
1. Central Htg ON/ OFF	<p>Enable or disable central heating operation.</p> <ul style="list-style-type: none"> Setting range: Enable/Disable Default: Enable
1-1 CH Set Temp	<p>Set the central heating target temperature (°C)</p> <ul style="list-style-type: none"> Setting range for central heating supply water: 40°C (Absolute MIN) – 90°C (Absolute MAX) Setting range for central heating return water: 30°C (Absolute MIN) – 65°C (Absolute MAX) Default: 60°C <p>This option is available only when "1. Central Htg ON/OFF" is set to "Enable".</p>
2. OTC ON/OFF	<p>Enable or disable the outdoor temperature compensation control option.</p>
2-1 K-Factor*	<p>K-Factor for the central heating</p>

Item	Description
3. WWSD Temp	<p>Set the Warm Weather Shut-down temperature.</p> <ul style="list-style-type: none"> Setting range: 10°C – 40°C Default: OFF
4. WWSD On Diff	<p>Set the differential temperature to deactivate the Warm Weather Shutdown.</p> <ul style="list-style-type: none"> Setting range: 1°C – 20°C Default: 3°C
5. Central Htg Control	<p>Select the heating control type.</p> <p>1: Supply Temperature 2: Return Temperature</p> <ul style="list-style-type: none"> Default: Supply Temperature
6. CH Heat Demand	<p>Set the heat demand control type for Navien Thermostat, OpenTherm, CH Thermostat and Switched Live.</p> <ul style="list-style-type: none"> Default: Navien Thermostat

* When the boiler is connected to an outdoor temperature sensor (optional), functioning may be activated according to outdoor temperature conditions and K-factor values using the parameters.

The graph shows how the set temperature is determined. K-factor values can be set using the front panel.

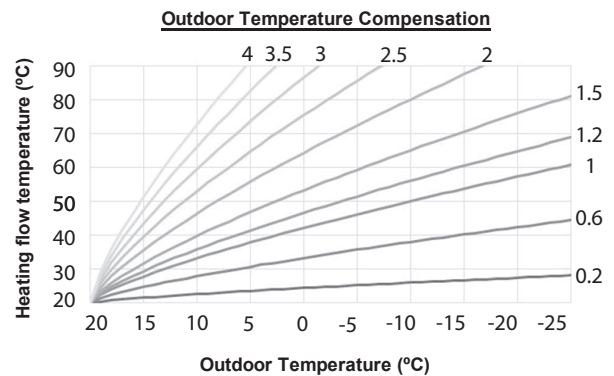

If there is an input from the outdoor temperature sensor, OTC (Outdoor Temperature Compensation) control will be enabled automatically. Also, if there is no input from the outdoor temperature sensor, OTC control will be disabled automatically.

10.6.3 Setting the DHW Operation

To set the boiler's DHW operation, press the Menu button (M), and then select "3. DHW Operation".

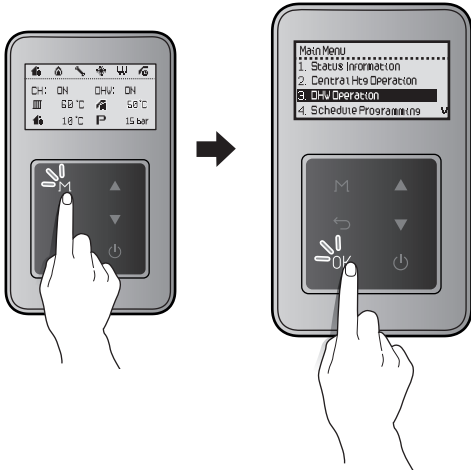

Press the Up button (▲) or the Down button (▼) to switch between the list items or to increase/decrease setting values. Press the OK button (OK) to select an item or to confirm after making changes.

Press the Back button (↶) to return to the previous screen or menu.

Item	Description
1. DHW Set Temp	Set the DHW temperature. <ul style="list-style-type: none"> Setting range: 30 – 65°C Default: 50°C
2. DHW Preheat	Activate the DHW preheat function. <p>Note</p> <ul style="list-style-type: none"> If the DHW preheat function is activated by the room controller, "RC Connected" will be displayed. The DHW preheat function cannot be activated, when the Heat Demand function is set to OpenTherm.

DHW Preheat - ECO Mode

Item	Description
1. OFF	Do not DHW Preheat
2. DHW_Intelligent	Set to detect DHW usage for repeat the detected cycle
3. DHW Schedule	Set to detect DHW usage for a week

If you select DHW Schedule, you can select the certain day to schedule the central heating modes.

Item	Description
1. 7 Day	Schedule a command for each day of the week.
2. 5 + 2 Day	Schedule a command for weekday and weekend.
3. 5 + 1 + 1 Day	Schedule a command for weekdays, Saturdays, and Sundays.
4. OFF (Not Used)	Disable the schedule function.

Set the DHW Schedule

When setting up the DHW option, select 'Weekly,' and select between 1 Day, 3 Day, and 7 Day to go to the Schedule menu.

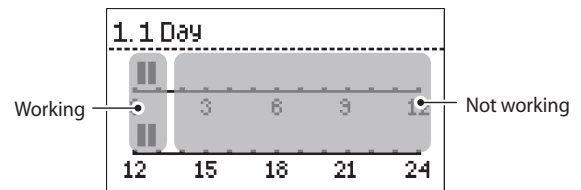

Press the Up button (▲) or the Down button (▼) to choose the scheduled time. You can choose the time in 30 minutes intervals.

DHW Preheat - None ECO Mode

Item	Description
1. Always ON	Always DHW Preheat

10.6.4 Setting the Schedule Programming

To set the boiler's schedule programming operation, press the Menu button (M), and then select "4. Schedule Programming".

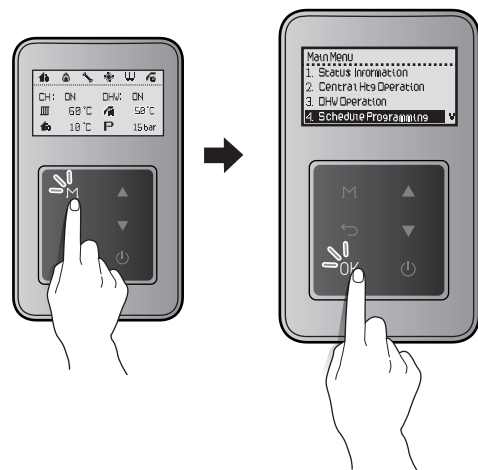

Press the Up button (▲) or the Down button (▼) to switch between the list items or to increase/decrease setting values. Press the OK button (OK) to select an item or to confirm after making changes.

Press the Back button (↶) to return to the previous screen or menu.

Item	Description
1. CH Schedule	Set the central heating weekly timer.
2. Schedule Check	Check the weekly schedule.

Note To select this option, you must set up the Time settings in the Configuration menu.

If you select an item, you can select the certain day to schedule the central heating modes.

Note The schedule settings and checking function cannot be used when the Heat Demand function is set to Navien Thermostat.

Item	Description
1. 7 Day	Schedule a command for each day of the week.
2. 5 + 2 Day	Schedule a command for weekday and weekend.
3. 5 + 1 + 1 Day	Schedule a command for weekdays, Saturdays, and Sundays.
4. OFF (Not Used)	Disable the schedule function.

Set the CH Schedule

When setting up the CH option, select 'Weekly,' and select between 1 Day, 3 Day, and 7 Day to go to the Schedule menu.

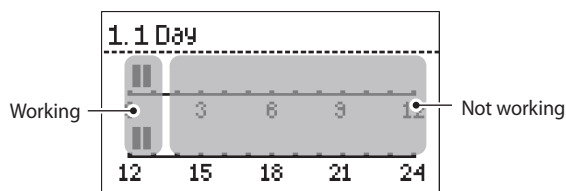

Press the Up button (▲) or the Down button (▼) to choose the scheduled time. You can choose the time in 30 minutes intervals.

10.6.5 Viewing Error History

To view the error history, press the Menu button (M), and then select "5. Error History".

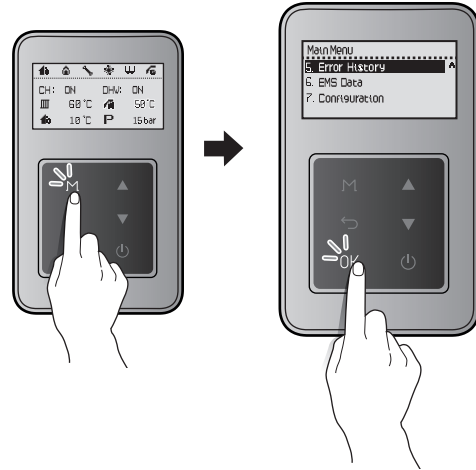

A list of 10 recent errors are displayed on the screen, with the most recent error displayed at the top of the list.

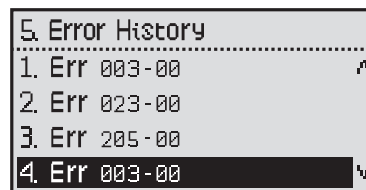

Press the Up button (▲) or the Down button (▼) to switch between the list of Errors. Press the OK button (OK) to select an error to view detailed information.

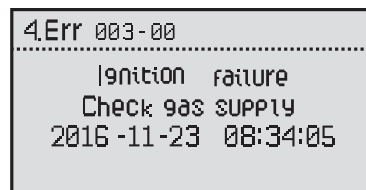

Press the Back button (↶) to return to the previous screen or menu.

- Note**
- The front panel display flashes in red and the error icon is displayed (flashing) when a level 1 error is detected. You can press the OK button (OK) to enter error display mode. Boiler operation is maintained during a level 1 error.
 - A level 1 error is automatically cleared when the problem is resolved.
 - You can press the Power button (⏻) to clear a level 1 error. Then, the error is cleared if the problem has been resolved.

10.6.6 Viewing Other System Information

To view the miscellaneous system information, press the Menu button (M), and then select "6. EMS Data".

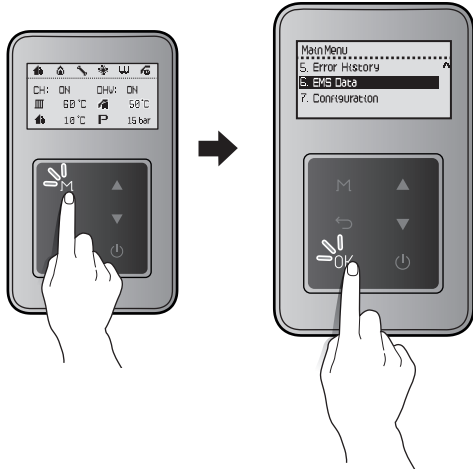

Press the Up button (▲) or the Down button (▼) to switch between the information items. Press the OK button (OK) to select an item and view the information.

Press the Back button (↶) to return to the previous screen or menu.

Item	Description
1. CH Operation Time	View monthly central heating operation logs.
2. DHW Operation Time	View monthly DHW operation logs.
3. Num of CH Operation	View the number of times the central heating operation function has been used.
4. Num of DHW Operation	View the number of times the DHW operation function has been used.
5. Num of Preheat Operation	View the number of times the preheat operation function has been used.
6. Gas Consumption	View monthly gas consumption.

10.6.7 Setting the Display Options

To set the front panel display options, press the Menu button (M), and then select "7. Configuration".

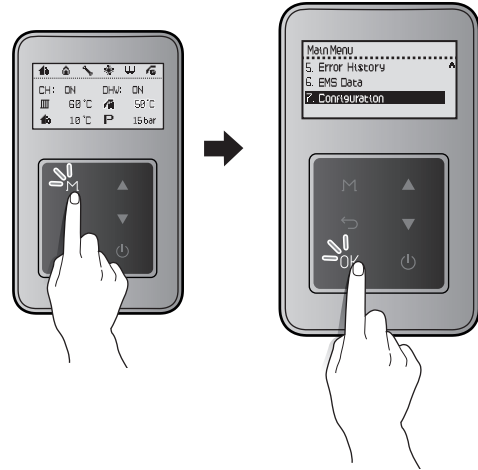

Press the Up button (▲) or the Down button (▼) to switch between the list items or to increase/decrease setting values. Press the OK button (OK) to select an item or to confirm after making changes.

Press the Back button (↶) to return to the previous screen or menu.

Item	Description
1. Language	Select the display language. 1. English • Default: English
5. Backlight Time Setting	Set the backlight time. • Setting range: 0 – 60 sec • Default: 2 sec

10.7 Accessing Advanced Menu Items

10.7.1 Viewing Service Information

To view the service information about the boiler, press the Back button (↶) and the Menu button (M) simultaneously for 3 seconds, and then select "1. Service Status Info".

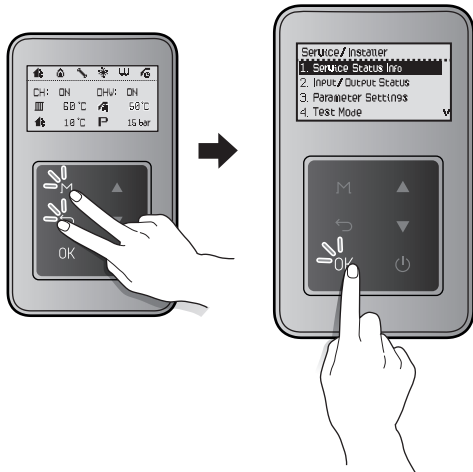

Press the Up button (▲) or the Down button (▼) to switch between the information items. Press the OK button (OK) to select an item and view the information.

Press the Back button (↶) to return to the previous screen or menu.

Item	Description
1. Elapsed Time After Install	Elapsed time since installation
2. HEX Overheat - No. of Times	Number of times the heat exchanger high limit stat has activated
3. Flame Loss - No. of Times	Number of times a flame loss/misfire has occurred
4. 2nd ignition - No. of Times	Number of second ignition attempts
5. 3rd ignition - No. of Times	Number of third ignition attempts
6. 4th ignition - No. of Times	Number of fourth ignition attempts
7. 5th ignition - No. of Times	Number of fifth ignition attempts

10.7.2 Viewing Input and Output Status

To view the boiler's input and output status, press the Back button (↶) and the Menu button (M) simultaneously for 3 seconds, and then select "2. Input/Output Status".

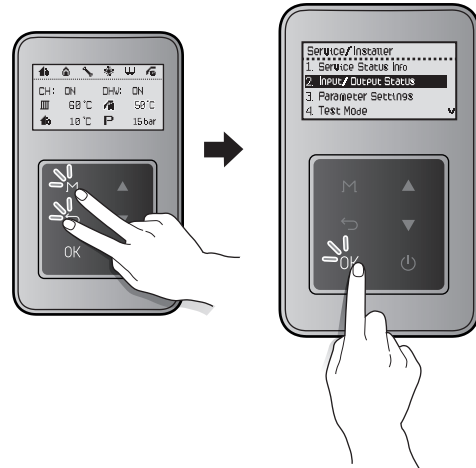

Press the Up button (▲) or the Down button (▼) to switch between the information items. Press the OK button (OK) to select an item and view the information.

Press the Back button (↶) to return to the previous screen or menu.

Item	Description
1. CH Switched Live Status	CH switched live input status
2. CH Thermostat Status	CH thermostat input status
3. Boiler Pump Status	Boiler pump output status
4. 3 Way Valve	3 Way valve output status
5. HTL Input Status	HTL input status

10.7.3 Setting the Operation Parameters

To set the boiler's operation parameters, press the Back button (↶) and the Menu button (M) simultaneously for 3 seconds, and then select "3. Parameter Settings".

! CAUTION

Parameters must be set by a qualified professional with an extensive understanding of the boiler system. Setting parameters improperly may lead to property damage or injury.

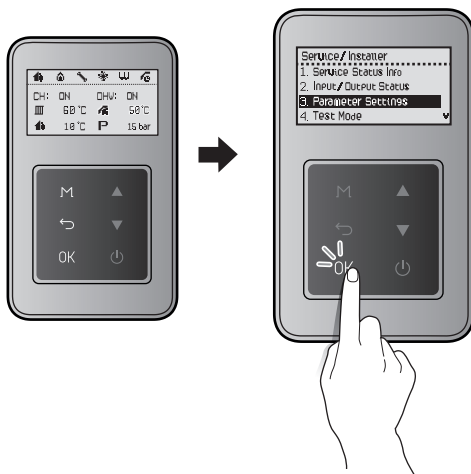

In the password screen, press the Up button (▲) or the Down button (▼) to change numbers and places, and press the OK button (OK) to enter the password.

The factory default password is "1234".



After entering the parameter setting screen, press the Up button (▲) or the Down button (▼) to switch between the parameters or to increase/decrease setting values. Press the OK button (OK) to select a parameter or to confirm after making changes.

Press the Back button (↶) to return to the previous screen or menu.

Item	Description
1. Supply MIN Set-point	Set the central heating supply minimum temperature. <ul style="list-style-type: none"> Setting range: 25°C – [MAX Set-point – 20°C] Default: 40°C
2. Supply MAX Set-point	Set the central heating supply maximum temperature. <ul style="list-style-type: none"> Setting range: [MIN Set-point + 20°C] – 90°C Default: 90°C
3. Return MIN Set-point	Set the central heating supply minimum temperature. <ul style="list-style-type: none"> Setting range: [MAX Set-point - 10°C] Default: 30°C
4. Return MAX Set-point	Set the central heating supply maximum temperature. <ul style="list-style-type: none"> Setting range: [MIN Set-point + 10°C] – 70°C Default: 65°C
5. CH Burning Off Diff	Set the temperature range to turn off central heating. <ul style="list-style-type: none"> Setting range: 0°C – 30°C Default: 2°C
6. CH Burning On Diff	Set the temperature range to turn on central heating. <ul style="list-style-type: none"> Setting range: 1°C – 30°C Default: 3°C
7. Anti Fast Cycling Time*	Set the anti-fast cycling time. <ul style="list-style-type: none"> Setting range: 0 – 20 min Default: 3 min
8. Freeze protection	Set the pump freeze protection temperature. <ul style="list-style-type: none"> Setting range: 6°C – 10°C Default: 10°C <p>Note The system freeze protection temperature is set based on the pump freeze protection temperature.</p>
9. Boiler Pump Delay	Set the boiler pump off delay time. <ul style="list-style-type: none"> Setting range: 30 – 40 min Default: 40 min

Item	Description
10. CH Min Limit	Set the central heating minimum heat capacity limit. <ul style="list-style-type: none"> Setting range: Central heating minimum capacity (%) – [central heating minimum capacity limit-20] % Default: Boiler's minimum heat capacity
11. CH Max Limit	Set the central heating maximum heat capacity limit. <ul style="list-style-type: none"> Setting range: (Central heating minimum capacity limit + 20) % – 100% Default: 100%
12. DHW Min Limit	Set the DHW supply minimum temperature. <ul style="list-style-type: none"> Setting range: DHW minimum capacity (%) – [DHW MAX capacity limit-20] % Default: Boiler's minimum heat capacity
13. DHW Max Limit	Set the DHW supply maximum temperature. <ul style="list-style-type: none"> Setting range: [DHW minimum capacity limit +20] % – 100% Default: 100%
14. DHW Wait Time	Set the DHW wait time. <ul style="list-style-type: none"> Setting range: 0 – 20 min Default: 5 min
15. CH Min Burning Time	Set the low-load combustion time at initial operation. <ul style="list-style-type: none"> Setting range: 0 – 20 min Default: 1 min
16. Burning Acceleration Time	Set the time to reach the maximum central heating capacity after initial operation. <ul style="list-style-type: none"> Setting range: 0 – 20 min Default: 3 min
17. DHW Priority Time	Sets the time duration that the boiler will remain in DHW priority.
18. Anti-Regionella	This function is designed to prevent legionella germs that can reside in the DHW tank.
19. Service Notif Time	Set the time for service notification. <ul style="list-style-type: none"> Setting range: 30 – 3650 days (10 years) It can be set in 10 day increments. Default: 1820 days (5 years)

Item	Description
20. Service Notif Cycle	Set the service notification according to the operating times. <ul style="list-style-type: none"> Setting range: 300 – 36500 cycles It can be set in 100 cycle increments. Default: 18200 cycles
21. Recirculation Usage	Sets a recirculation pump usage.
22. Recirculation Interval Time	Sets a recirculation interval time.
23. Recirculation Sampling Time	Sets a recirculation sampling time.
24. Recirculation off Differential Temp	Sets a recirculation off differential temperature.
25. Factory Reset	Initialise all parameter settings (panel and main controller) to factory default.
26. P/W Change	Change the parameter setting password. Press the Up button (▲) or the Down button (▼) to change numbers and places, and press the OK button (OK) to save the new password.

10.7.4 Diagnosing the Boiler System

To run a series of test procedures for a system diagnosis, press the Back button (↶) and the Menu button (M) simultaneously for 3 seconds, and then select "4. Test Mode".

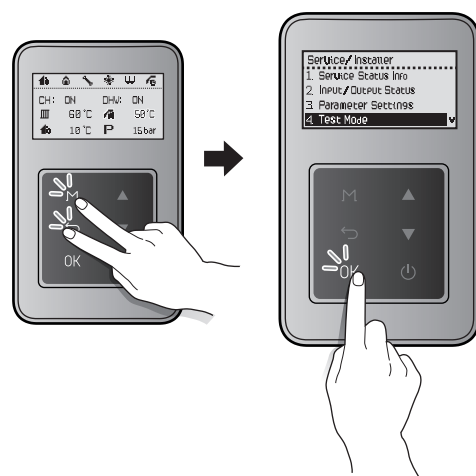

Press the Up button (▲) or the Down button (▼) to switch between the test procedures. Press the OK button (OK) to run a test procedure.

Note During the test mode, the boiler stops combustion.

Press the Back button (↶) to return to the previous screen or menu.

Item	Description
1. Fan Motor	<p>Test the fan operation.</p> <p>From a stopped state, the fan speed gradually increases and reaches the maximum speed at 6500 RPM, and then the fan speed decreases until the fan stops operating.</p> <p>Note Except for the Power button (⏻), the buttons do not work during fan motor test mode.</p>
2. Boiler Pump	<p>Test the boiler pump operation.</p> <p>On (10 seconds) -> Off (5 seconds) -> On (10 seconds) for 5 boiler pump operation cycles</p> <p>Note Except for the Power button (⏻), the buttons do not work during boiler pump test mode.</p>
3. 3 Way Valve	<p>Test the 3 way valve operation.</p> <ul style="list-style-type: none"> The 3 way valve is turned on as soon as you enter the test mode. Press the OK button (OK) to toggle the valve operation [On (DHW) -> Off (CH)/Off (CH) -> On (DHW)].
4. Dual Venturi	<p>Test the dual venturi operation.</p> <p>Press the OK button (OK) to toggle the dual venturi operation [On (DHW) -> Off (CH) -> On (DHW)].</p>

10.7.5 Setting the Special Operation Modes

To operate the boiler in special operation modes, press the Back button (↶) and the Menu button (M) simultaneously for 3 seconds, and then select "5. Special Operations".

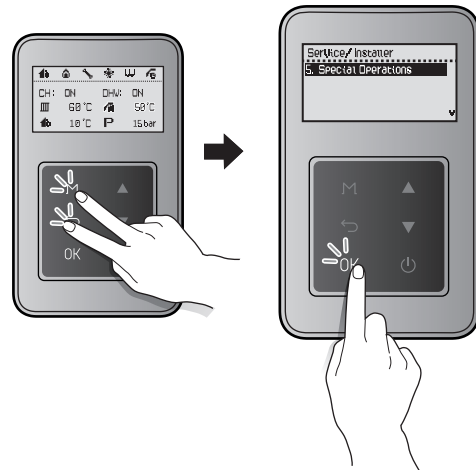

Press the Up button (▲) or the Down button (▼) to switch between the operation modes. Press the OK button (OK) to select an operation mode.

The boiler resumes operation in normal operation mode if no input is detected for 3 hours.

Press the Back button (↶) to return to the previous screen or menu.

Item	Description
1. Normal	Set the boiler to run in normal operation mode.
2. 1st MIN	Set the boiler to run in 1st stage minimum operation mode.
3. 1st MAX	Set the boiler to run in 1st stage maximum operation mode.
4. CH 2nd MAX	Set the boiler to run in 2nd stage central heating maximum operation mode.
5. DHW 2nd MAX	Set the boiler to run in 2nd stage DHW maximum operation mode.
6. 2nd MIN	Set the boiler to run in 2nd stage minimum operation mode.

10.8 Error Codes

When an error code appears on the front panel, refer to the following chart for a definition and possible remedy for the situation.

Item	Error Code	Description	Reset
Combustion	E001	Overheating of heat exchanger	Manual
	E003	Ignition failure	Manual
	E004	False flame detection	Auto
	E012	Flame loss	Manual
	E016	Heat exchanger overheat	Manual
	E030	Abnormal exhaust temperature	Manual
	E046	Abnormal operation: Heat exchanger overheating sensor	Auto
	E047	Abnormal operation: Exhaust thermostat	Manual/Auto
	E060	Abnormal operation: Dual venturi limit switch	Alarm
Air Circulation	E109	Abnormal operation: Fan	Manual
	E110	Exhaust blockage (Condensate blockage)	Manual
	E127	Abnormal operation: APS	Auto/Manual
Central Heating Circulation	E205	Heating supply thermistor open or short circuit	Auto
	E218	Heating return thermistor open or short circuit	Alarm
	E291	Supply/Return inversion limit	Manual Reset
Water Supply	E302	Low water pressure	Auto
	E352	High water pressure	Auto
	E353	Abnormal operation: Water pressure sensor	Auto
DHW Circulation	E407	DHW Outlet thermistor Open or Short Circuit	Alarm
	E421	DHW Inlet thermistor Open or Short Circuit	Auto
	E434	Abnormal operation: Flow control valve	Alarm
	E441	DHW Outlet 2 thermistor open or short circuit	Alarm
	E445	Abnormal operation: Mixing valve	Alarm
	E480	DHW tank thermistor open or short circuit	Alarm
Controller (PCB)	E515	Abnormal operation: Relay feedback (PCB)	Manual
	E517	Abnormal operation: DIP switch setting (PCB)	Manual
	E594	Abnormal operation: EEPROM (PCB)	Alarm/Manual
	E598	Abnormal operation: Panel real time clock	Alarm
Controller (MCU)	E615	Abnormal operation: Input and memory (MCU)	Manual
Installation	E740	Abnormal operation: Outdoor temperature sensor	Auto
	E782	Abnormal operation: Main panel communication	Auto
	E783	Abnormal operation: OpenTherm remote control	Auto
	E787	Abnormal operation: Reset device	Manual/Power Reset
	E788	Abnormal operation: Gas type settings	Manual

If the error code is not cleared by resetting the boiler functioning (see "10.5 Resetting the Boiler") or if it occurs repeatedly, call the nearest official Technical Assistance Service (TAS), indicating the number of the error code appearing on the front panel.

11. Maintaining the Boiler

11.1 Cleaning the Boiler

⚠ CAUTION

Make sure the boiler is turned off and the power supply is disconnected before cleaning the boiler. The boiler may remain hot for several minutes after it is turned off. To prevent burns, wait until the boiler has cooled down before cleaning.

To clean the boiler, wipe the outside with a damp cloth. Use a non-acidic, non-abrasive cleaner to remove any surface stains. The front panel is moisture resistant, but it is not waterproof. Keep it as dry as possible.

11.2 Draining the Boiler

You will need to drain either both the central heating side and domestic hot water (DHW) side, or one side only before performing maintenance tasks, such as cleaning the adapter filter, or to prevent the boiler from freezing when it will not be used for an extended period.

Refer to the "2.5 Dimensions" on page 15 for details about part locations.

To drain the boiler:

1. Place a bucket under the boiler, to collect the residual water inside the boiler.
2. Press the Power button (⏻) on the front panel to turn off the boiler.

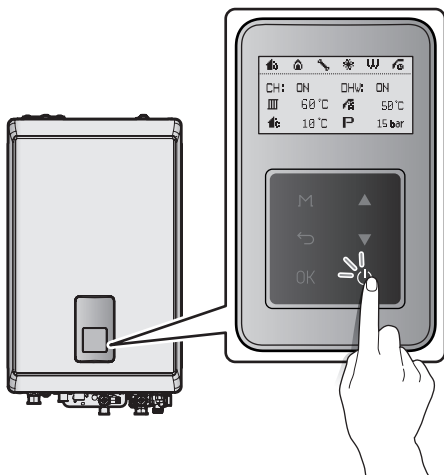

3. Disconnect the power supply from the boiler.
4. Close the gas valve.

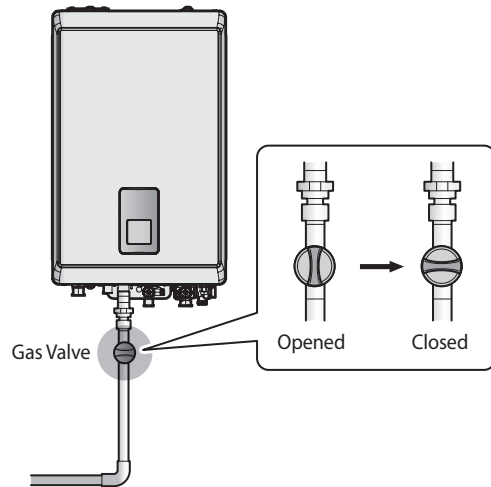

5. Close the water supply valve on the inlet to the boiler. If there is no valve, turn off the water supply at the water main.

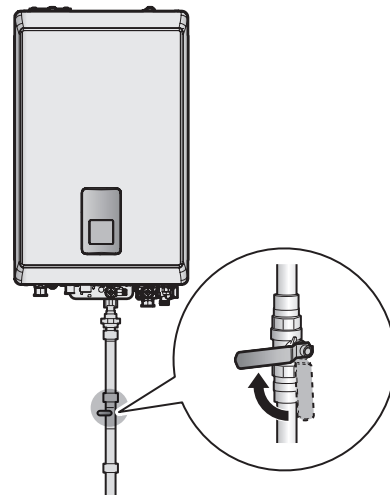

- Close off any heating zones that do not require draining and open a purge valve to drain the central heating side. Open all domestic hot water taps completely to drain the water heating side. The water that remains in the plumbing lines will drain out.

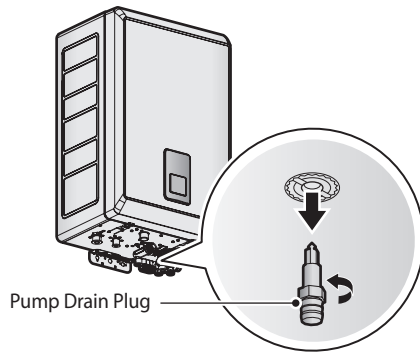

- Open the pump drain plug.
- Allow the residual water to drain from the boiler.
- When the water is completely drained, reinsert the return adapter filter and close the pump drain plug.
- To refill the boiler follow the steps of "Draining the Boiler" in reverse.

11.3 Cleaning the Return Adapter Filter

To clean the filter:

- Drain the boiler. Refer to "11.2 Draining the Boiler" on page 54.
- Remove the filter and rinse it with clean running water (cold). If necessary, scrub it clean with a brush.

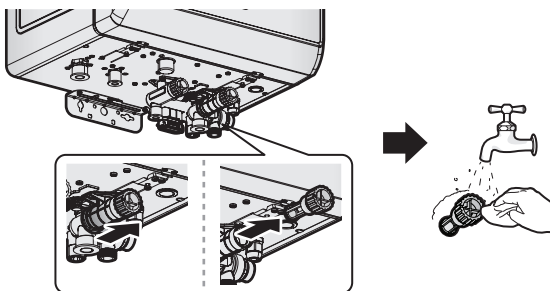

- Reinsert and tighten the filter.
- Fill the boiler and check for proper operation.

11.4 Protecting the Boiler from Freezing

! CAUTION

Damage due to freezing is not covered by the Navien limited warranty.

If the boiler is connected to a circuit that could freeze, the circuit pipes must be suitably insulated. All pipes installed outdoors must be insulated according to applicable legislation.

The boiler electronic control includes a freeze protection function that prevents the boiler from freezing in very cold weather. It remains on standby and takes priority over all other boiler functions while the boiler is connected to the electrical mains and gas supply, i.e. it remains enabled even when the boiler is in standby position.

To ensure that the boiler does not freeze, follow these guidelines:

- Do not unplug the power supply cord**, except for routine maintenance. The boiler has a freeze protection function that requires electricity. The freeze protection function will operate regardless of whether or not the power is turned on or off, as long as the electric supply is still connected.
- Do not close the gas valve**, except for routine maintenance, as this will limit additional freeze protection.
- If the boiler will not be used for an extended period, drain the boiler.**

If the power or gas supplies must be disconnected for an extended period, drain the boiler. Freezing damage may occur if there is water remained in the boiler in cold weather.

If hot water will not flow and you suspect that the boiler is frozen, follow these steps:

1. Press the Power button (⏻) on the front panel to turn off the boiler.
2. Close the gas valve.

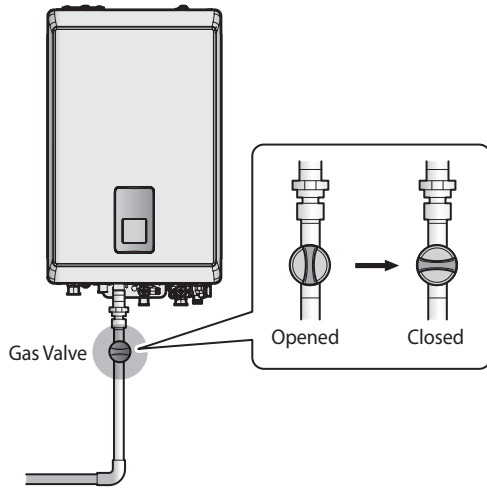

3. Open the hot water tap that is closest to the boiler.
4. Use a hair dryer or a portable electric heater to heat up both the primary and secondary heat exchangers.
5. Check every few minutes to see if water is running at the open tap.

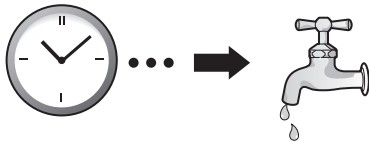

6. When the water starts flowing again, check the boiler and piping for leaks. If you detect any leaks or the boiler is not operating properly, contact an authorised technician or licensed professional.

Note This boiler requires very little maintenance, however a qualified technician should inspect the boiler at the beginning of every heating season and/or when there is a problem.

11.5 Maintenance Schedules

Owner maintenance	
Daily	<ul style="list-style-type: none"> • Check boiler area • Check pressure / temperature gauge
Monthly	<ul style="list-style-type: none"> • Check flue piping • Check condensate drain
Periodically	<ul style="list-style-type: none"> • Check flue termination screens
Every 6 months	<ul style="list-style-type: none"> • Check boiler piping (gas and water) for leaks
Non-heating season	<ul style="list-style-type: none"> • Shut boiler down (unless boiler used for domestic hot water)

Service technician (See the following instructions)	
Annual Start-up	<p>General:</p> <ul style="list-style-type: none"> • Address reported problems • Inspect interior; clean and vacuum if necessary • Clean condensate trap and fill with fresh water • Check for leaks (water, gas, flue, condensate) • Verify flue and air lines are in good condition and sealed tight • Check system piping • Check control settings • Check ignition and flame rod (clean and reposition) • Check wiring and connections • Flame inspection (stable, uniform) • Flame signal
	<p>If combustion or performance indicate need:</p> <ul style="list-style-type: none"> • Clean heat exchanger • Remove and clean return adapter filter



WARNING

- Follow the service and maintenance procedures given throughout this manual and in component literature shipped with the boiler. Failure to perform the service and maintenance could result in damage to the boiler or system.
- Failure to follow the directions in this manual and component literature could result in severe personal injury or substantial property damage.
- The boiler should be inspected annually only by a qualified service technician. In addition, the maintenance and care of the boiler must be performed to assure maximum boiler efficiency and reliability. Failure to service and maintain the boiler and system could result in equipment failure.
- Electrical shock hazard – Turn off power to the boiler before any service operation on the boiler except as noted otherwise in this instruction manual. Failure to turn off electrical power could result in electrical shock, causing severe personal injury.

Addressing the Reported Problems

Inspect any problems reported by the owner and correct before proceeding.

Inspecting the Installation Area

1. Verify that boiler area is free of any combustible materials, petrol and other flammable vapours and liquids.
2. Verify that air intake area is free of any of the contaminants listed in Installation & Operation Manual. If any of these are present in the boiler intake air vicinity, they must be removed. If they cannot be removed, reinstall the air and flue lines per the Installation & Operation Manual.

Inspecting the Boiler Interior

1. Remove the front cover and inspect the interior of the boiler.
2. Vacuum any sediment from inside the boiler and components. Remove any obstructions.

Cleaning the Condensate Trap

1. Inspect the condensate drain line, condensate fittings, and condensate trap.
2. Remove any sediment from the trap.
3. Fill with fresh water until the water begins to pour out of the drain.

Checking all Piping for Leaks

Eliminate all system or boiler leaks. Continual fresh makeup water will reduce boiler life. Minerals can build up in sections, reducing heat transfer, overheating heat exchanger, and causing heat exchanger failure. Leaking water may also cause severe property damage.

1. Inspect all water and gas piping and verify to be leak free.
2. Look for signs of leaking lines and correct any problems found.

Checking the Flue System and Air Piping

1. Visually inspect the entire gas flue system for blockage, deterioration or leakage. Repair any joints that show signs of leakage. Verify that air inlet pipe is connected and properly sealed (if installed).
2. Verify that boiler flue discharge and air intake are clean and free of obstructions.



WARNING

Failure to inspect for the above conditions and have them repaired can result in severe personal injury.

Checking the Water System

1. Verify all system components are correctly installed and operational.
2. Check the cold fill pressure for the system. Verify it is correct (must be a minimum of 0.8 bar).
3. Watch the system pressure as the boiler heats up (during testing) to ensure pressure does not rise too high.

Note

- If the system contains glycol, test for proper concentration as recommended by manufacturer.
- Excessive pressure rise indicates expansion tank sizing or performance problem.

4. Inspect automatic air flues and air separators. Remove air flue caps and briefly press push valve to flush flue.
5. Replace caps. Make sure flues do not leak. Replace any leaking flues.

Inspecting the Ignition and Flame Detector Electrodes

1. Remove the ignition and flame detector electrodes from the boiler heat exchanger.
2. Remove any deposits accumulated on the ignition/flame detector electrode. If the electrodes cannot be cleaned satisfactorily, replace with new ones.
3. Replace ignition/flame detector electrode, making sure gasket is in good condition and correctly positioned.

Checking the Ignition Ground Wiring

1. Check that the ground wire is in good condition and securely attached to the boiler casing.
2. Check ground continuity of wiring using continuity meter.
3. Replace ground wires if ground continuity is not satisfactory.

Checking all Boiler Wiring

Inspect all boiler wiring, making sure wires are in good condition and securely attached.

Checking the Control Settings

Check settings of external limit controls (if any) and adjust if necessary.

Performing Start-up and Checks

1. Start boiler and make sure that the boiler is operating properly.
2. Verify cold fill pressure is correct and that operating pressure does not go too high.

Check the Burner Flame

1. Inspect flame through observation window.
2. If the flame is unsatisfactory at either high fire or low fire, check for obstructions in the flue.

Review with the Owner

1. Review the User's Information Manual with the owner.
2. Emphasize the need to perform the maintenance schedule.
3. Remind the owner of the need to call a licensed contractor should the boiler or system exhibit any unusual behaviour.
4. Remind the owner to follow the proper shutdown procedure and to schedule an annual start-up at the beginning of the next heating season.

12. Appendices

12.1 Gas Conversion

This boiler is configured for Natural Gas at the factory. If conversion to Propane Gas is required, use the conversion kit supplied with the boiler.

WARNING

This conversion kit must be installed by a qualified service agency* in accordance with all applicable codes and requirements of the authority having jurisdiction. The information in these instructions must be followed to minimise the risk of fire or explosion or to prevent property damage or personal injury. The qualified service agency is responsible for the proper installation of this kit. The installation is not proper and complete until the operation of the converted appliance is checked as specified in the manufacturer's instructions supplied with the kit.

* A qualified service agency is any individual, firm, corporation or company which either in person or through a representative is engaged in and is responsible for the connection, utilization, repair or servicing of gas utilization equipment or accessories; who is experienced in such work, familiar with all precautions required, and has complied with all of the requirements of the authority having jurisdiction.

Tools Required:

- Phillips Screwdriver
- Flathead Screwdriver
- $\frac{5}{32}$ in or 4 mm Allen Wrench
- Combustion Analyser or Dual Port Manometer
- Gas Leak Detector

Included Items:

- Gas Orifice (refer to below table)

Model	G20	G31
NCB700-42C	Ø4.4/Ø6.4	Ø3.65/Ø3.95
NCB700-54C	Ø4.8/Ø7.5	Ø4.0/Ø5.65

Table 1. Orifice Size

- Gas Pressure and Conversion Kit Number Labels

Procedure:

1. Turn off both gas and water supply to the boiler.
2. Unfasten the 2 latches (at the top) and remove 2 screws (at the bottom) to remove the front cover to gain access to the internal components. See Figure 1 for illustration of the front cover on the unit.

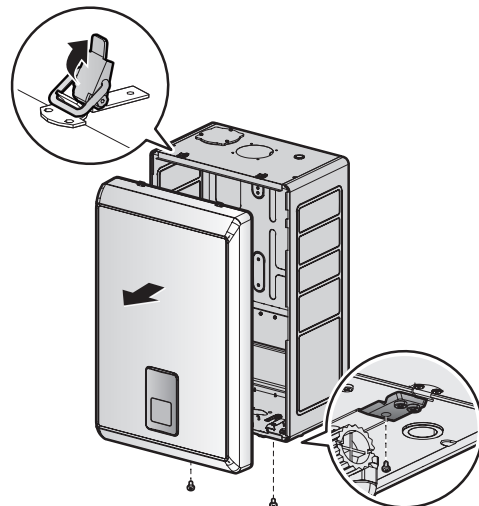
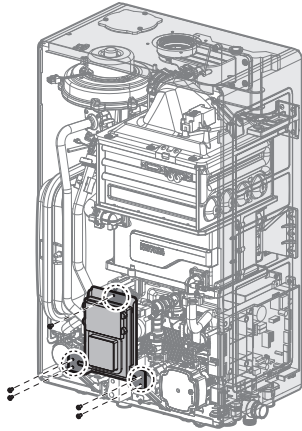

Figure 1. NCB700 Series Front cover

3. Remove the front cover and place it in a safe location to prevent accidental damage.
4. Label all the wires on the PCB.
5. Disconnect all the wires.

6. Loosen the five screws indicated in the figure.



7. Remove the front panel assembly.

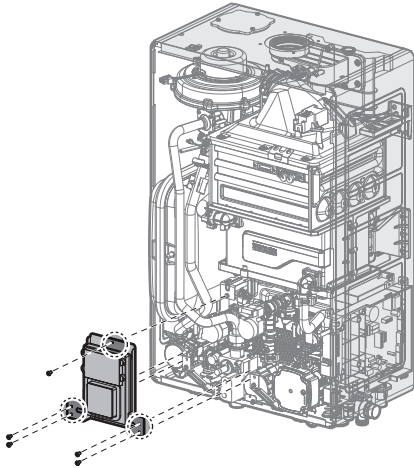

8. With the internal components exposed, locate the gas inlet pipe and the gas valve in the middle of the unit, as shown in Figure 2-1 and Figure 2-2.

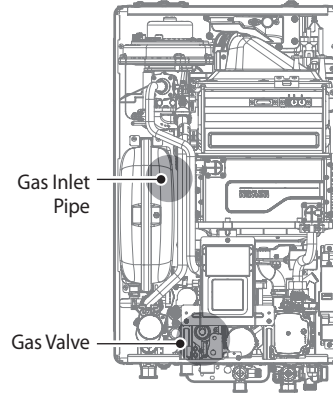

Figure 2-1. NCB700-42C Internal Components

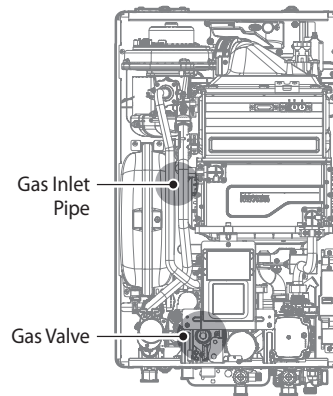

Figure 2-2. NCB700-52C Internal Components

9. Loosen the hex nut at location A - the connection above the gas valve where it connects to the pipe. See Figure 3 for reference. Once the hex nut is loose, carefully separate the pipe from the gas valve.
10. Once the gas inlet pipe is detached from the gas valve, find location B - the connection above the gas valve where it is attached to the fan motor assembly. Carefully remove the four screws by hand using a Phillips screwdriver and pull the gas inlet pipe away from the fan assembly to access the gas orifice.

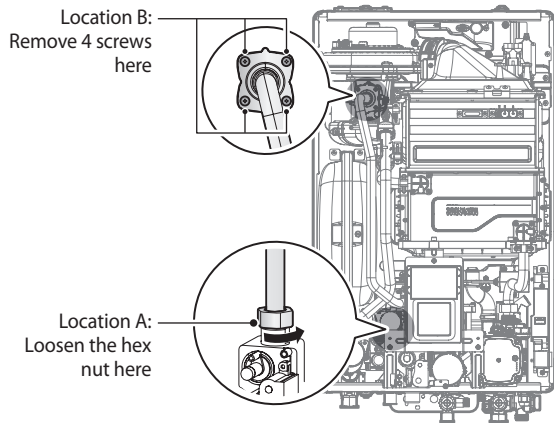

Figure 3. Detaching Gas Inlet Pipe from Gas Valve and Fan Motor Assembly

Once the Gas Orifice is exposed, remove the two screws that hold the part in place. Remove the Gas Orifice from its housing and prepare the new Gas Orifice for the LP conversion for installation.

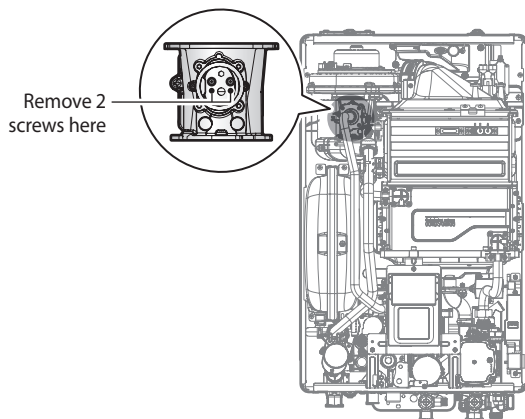

Figure 4. Access to Gas Orifice in Fan Assembly

WARNING

- Do not adjust or attempt to measure gas valve outlet pressure. The gas valve is factory-set for the correct outlet pressure. This setting is suitable for natural gas and propane, requiring no field adjustment.
- Attempting to alter or measure the gas valve outlet pressure could result in damage to the valve, causing potential severe personal injury or substantial property damage. Navien NCB700 boilers are shipped ready to fire natural gas only.

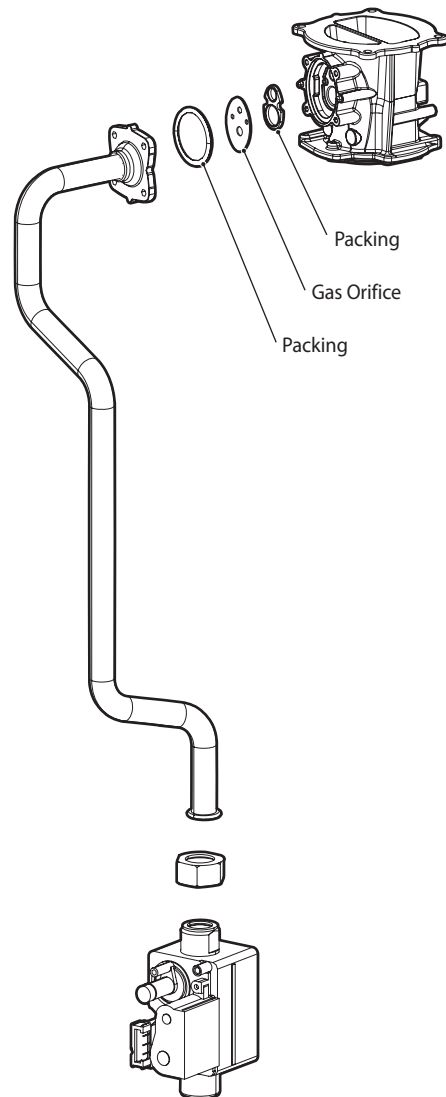

Figure 5-1. Exploded View of Gas Pipe Assembly (NCB700-42C)

DANGER

A high voltage in the Fan Motor Assembly may cause an electrical shock resulting in severe injury or death.

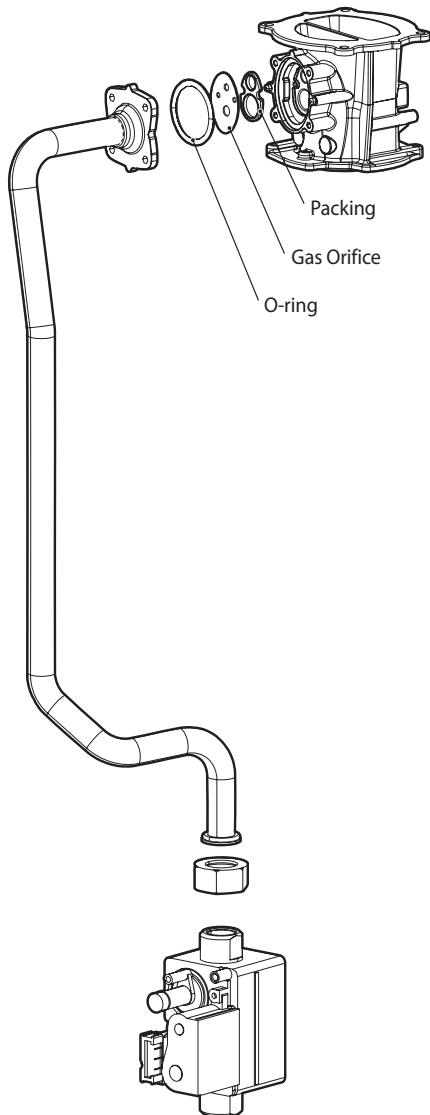

Figure 5-2. Exploded View of Gas Pipe Assembly (NCB700-52C)

! DANGER

See Figure 5-2. Inspect the O-ring between the venturi and gas valve inlet adapter whenever they are disassembled. The O-ring must be in good condition and must be installed. Failure to comply will cause a gas leak, resulting in severe personal injury.

Replace the old Orifice piece with the new part for use with LP gas. Ensure that the Orifice is properly seated inside the port before proceeding to the next step.

11. Replace the gas inlet pipe to its original position and use all screws to secure all connections.

Note Do not overtighten as this may damage or crack the components.

12. Check the labels carefully and then connect all the wires.

13. Set the front panel DIP Switch to change the gas type.

! WARNING

Ensure that you have turned off the power to the boiler before accessing the DIP switches.

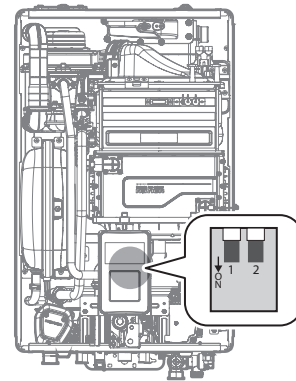

Figure 6. Set the DIP switches

Switch	Function	Setting	
1 & 2	Fuel Selection	G20 (LNG)	1-OFF, 2-OFF
		G30 (LPG)	1-ON, 2-OFF
		G31 (LPG)	1-ON, 2-ON

Table 1. The DIP Switch Setting by Fuel Selection

! DANGER

- When conversion is required, be sure to set the front panel DIP switches according to the supply gas type.
- Failure to properly set the DIP switches could cause carbon monoxide poisoning, resulting in severe personal injury.

14. Turn on the gas and water supply to the boiler.
15. Measure and adjust the gas/air ratio.
 - a. Loosen the screw, rotate the plate and remove the gasket to access the emissions monitoring port as shown in Figure 7.
 - b. Insert the analyser into the port (Figure 7).

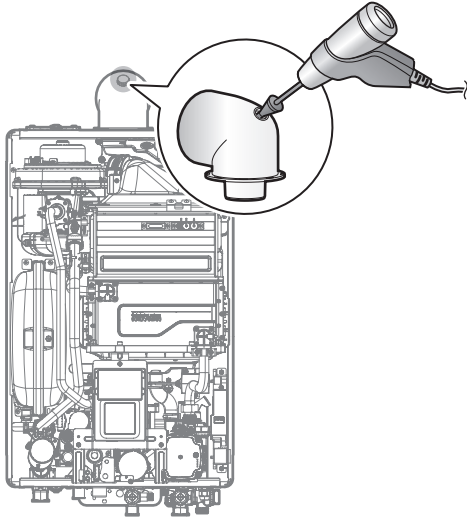

Figure 7. Insert the Analyser

Model	Gas Type	Max	Min
		%CO ₂	%CO ₂
NCB700-42C	G20	8.90%	8.35%
	G31	10.40%	10.25%
NCB700-54C	G20	8.90%	8.35%
	G31	10.40%	10.25%

Table 2. CO₂ Value

(CO₂ values for high fire must be within 0.5% and CO₂ values for low fire must be within 0.3% of the values listed.)

- c. Fully open several hot water fixtures and set the boiler to operate, and proceed Gas Setup Wizard.

Note For proceeding Gas Setup Wizard for gas type selection, refer to "10.3 Start-Up Wizard" on page 42.

Measure the CO₂ value at low fire.

If the CO₂ value is not within 0.5% of the value listed in Table 2, the gas valve set screw will need to be adjusted. If adjustment is necessary, locate the set screw as shown in Figure 8. Using a ⁵/₃₂ in or 4 mm Allen wrench, turn the set screw no more than ¹/₄ turn clockwise to raise or counterclockwise to lower the CO₂ value.

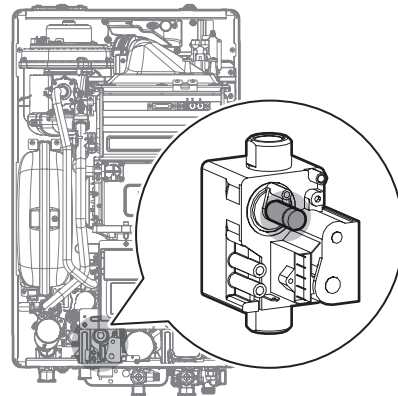

Figure 8. Set Screw Location

Note The set screw is located behind the screw-on cover. This must be removed first.

- d. After Gas Setup Wizard is done, operate at 1-stage MIN mode.

Note For operation mode selection, refer to "10.7.5 Setting the Special Operation Modes" on page 52.

- e. Fully open several hot water fixtures and set the boiler to operate at 2-stage D. MAX mode (refer to "10.7.5 Setting the Special Operation Modes" on page 52). Measure the CO₂ value at high fire. If the CO₂ values do not match Table 2 at high fire, do not adjust the gas valve. Check for the proper Gas Orifice.

! DANGER

Improper gas valve settings can cause severe personal injury or substantial property damage.

Model	Gas type			G20	G31	
				[20 mbar]	[37 mbar]	
	Load	Kcal/h	kW	Consumption kW	Gas flow m ³ /h	Gas flow m ³ /h
NCB700-42C	Max.	30,960	36.0	36.8	3.941	0.375
	Min.	2,924	3.4	3.5	1.479	0.141
NCB700-54C	Max.	30,960	36.0	36.8	3.941	0.375
	Min.	2,924	3.4	3.5	1.479	0.141

12.2 Cleaning the Heat Exchanger

WARNING

Before cleaning the heat exchanger, make sure the boiler is off.

To properly maintain the boiler, you should clean the heat exchanger annually.

To clean the heat exchanger:

1. Press the Power button (⏻) on the front panel to turn off the boiler.

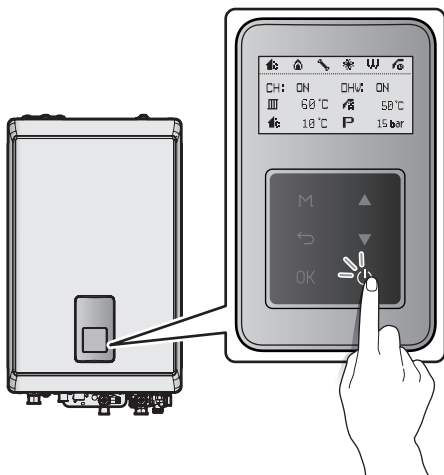

2. Disconnect the power supply to the boiler.
3. Turn off both gas and water supply to the boiler.

Note Wait at least 30 minutes for the heat exchanger to cool down.

4. Unfasten the 2 latches (at the top) and remove 2 screws (at the bottom) to remove the front cover to gain access to the internal components.

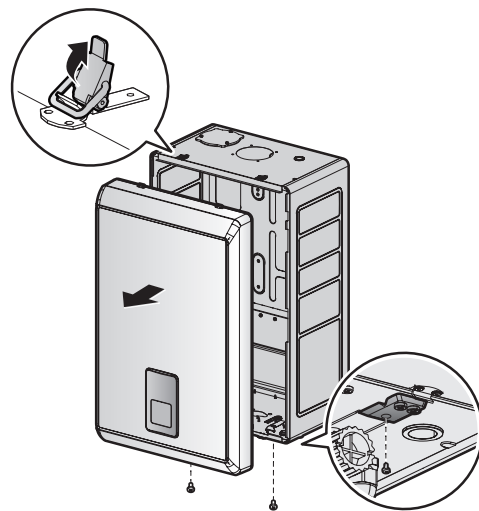

5. Once the front cover is removed, place it in a safe location to prevent accidental damage.

- Loosen the five screws holding the front panel and remove the front panel.

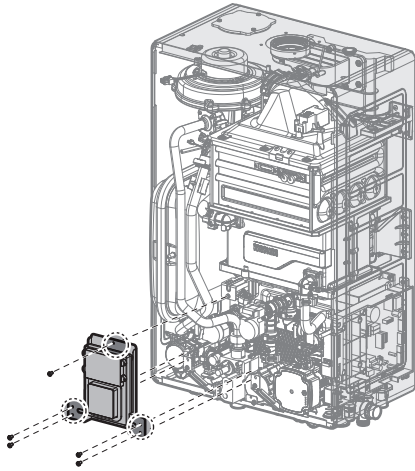

Note When removing the front panel, label all wires and make sure all wires are disconnected.

- Use a Phillips screwdriver to remove the four screws where gas inlet pipe is attached to the fan motor assembly. Loosen the hex nut located above the gas valve and remove the gas pipe.

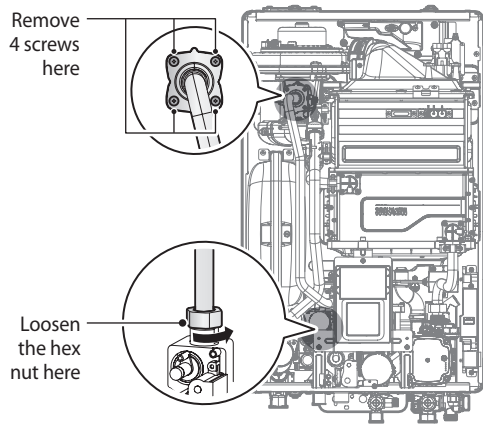

- Remove the screw connecting the fan motor assembly and the mixing chamber, and then remove the fan motor assembly.

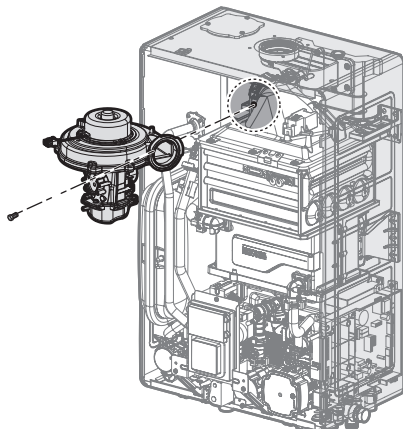

- Remove the five bolts securing the chamber brackets.

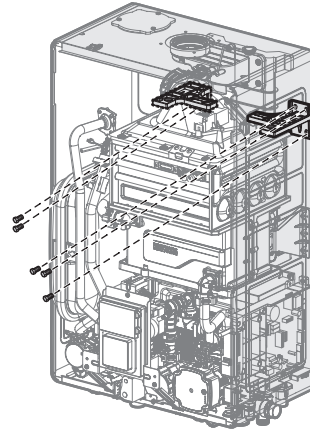

- Remove the two screws connecting the ignition transformer to the heat exchanger and then remove the ignition transformer.

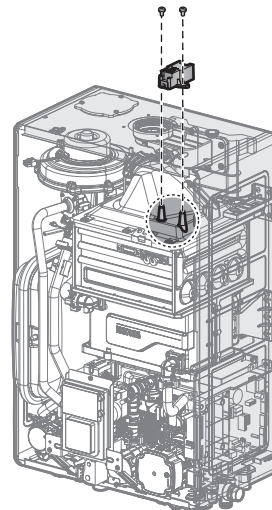

11. Remove the rubber packing at the top of the cover and put a Phillips screwdriver into the hole, and then loosen the middle bolt located at the back of the burner.

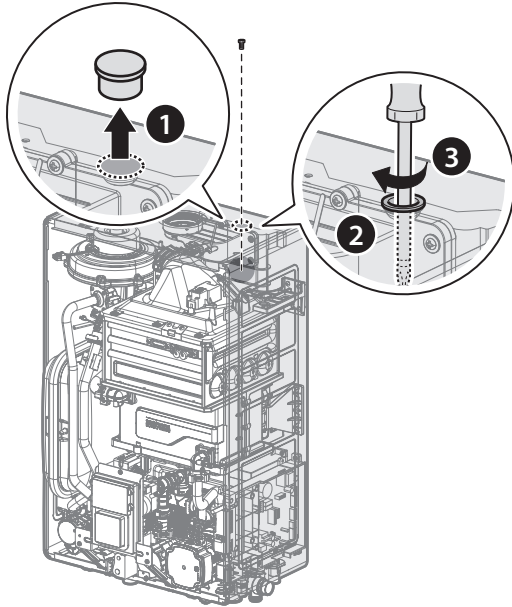

12. Remove the six bolts connecting the mixing chamber and the heat exchanger, and then remove the mixing chamber, burner and the chamber bracket.

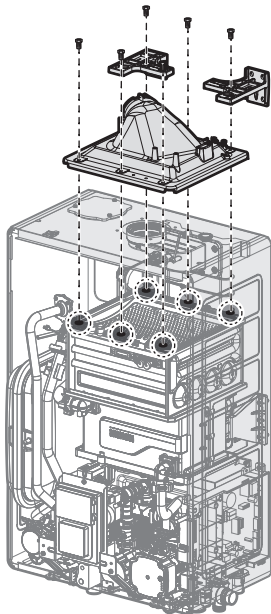

13. Use the brush to dislodge the debris and pour water down the channels to flush out the debris.

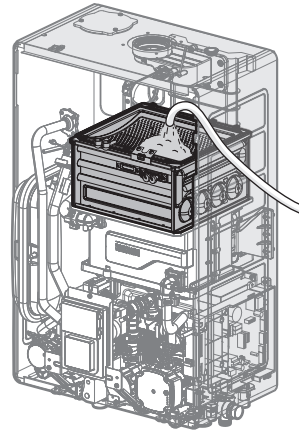

- Note**
- It is important to keep electric parts of the boiler safe from water.
 - Navien recommends to use a hose.
 - If the water pressure of the hose is too high, water may splash to other electric parts of the boiler. Keep the water pressure of the hose as low as it can.
 - If the boiler is installed in high area and you cannot see the inside of the heat exchanger, use a solid support and be careful not to fall.

14. As cleaning the heat exchanger is finished, reassemble the parts.

- Note** This boiler requires very little maintenance, however a qualified technician should inspect the boiler at the beginning of every heating season and/or when there is a problem.

12.3 Wiring Diagram

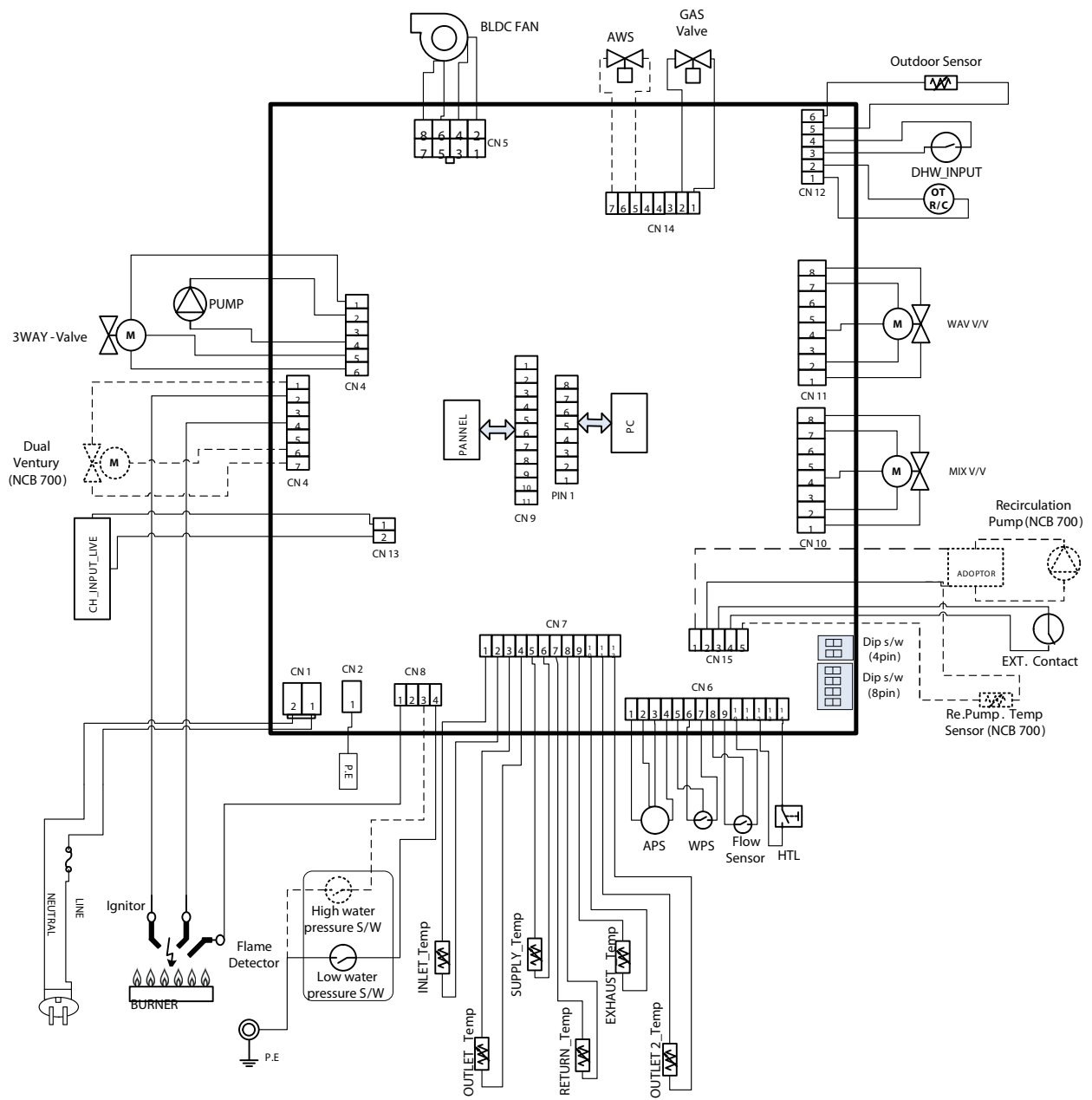

12.4 Ladder Diagram

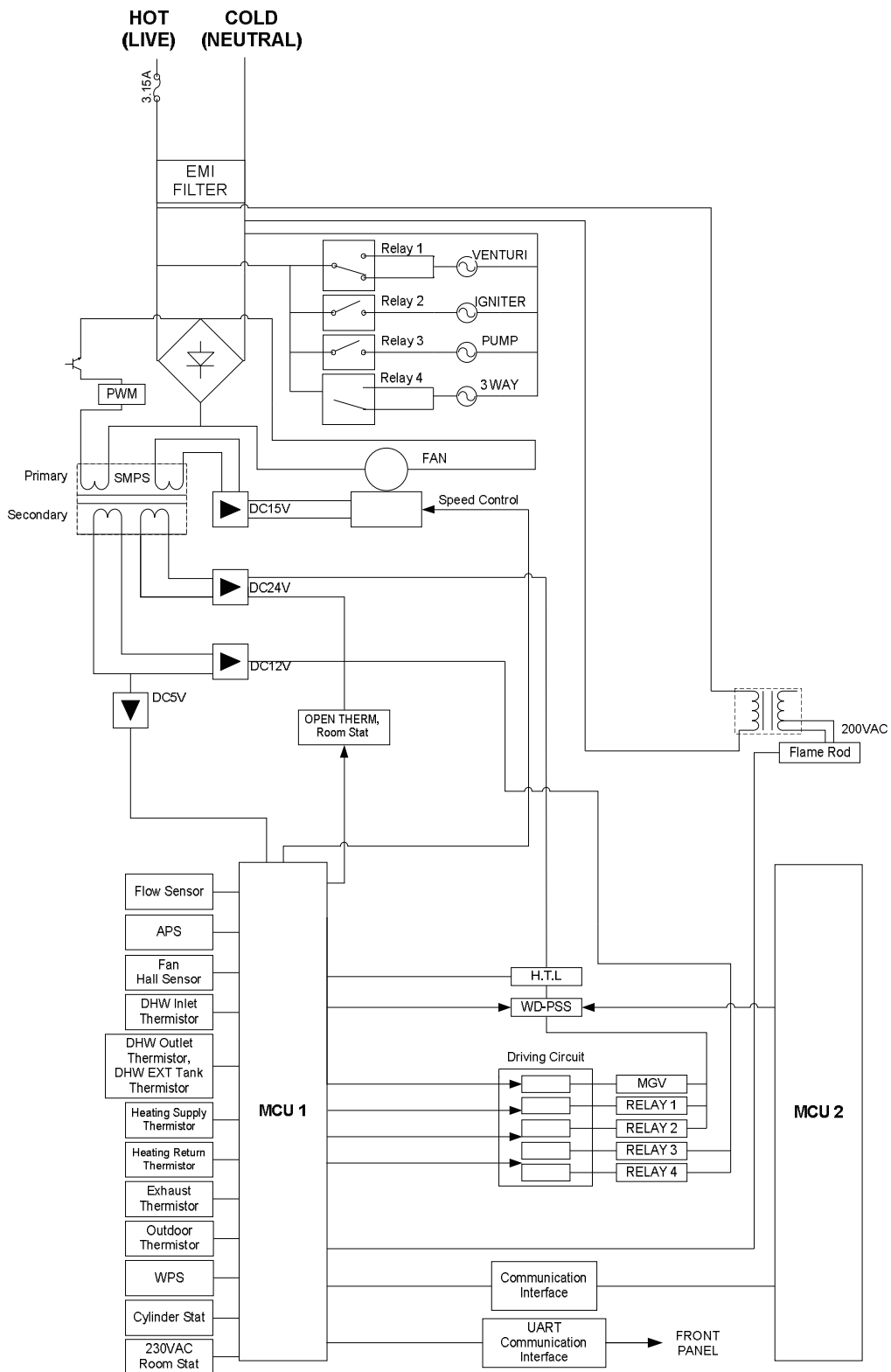

12.5 Outdoor Temperature Sensor (Optional)

Outdoor Temperature Sensor Installation

1. Pull out the sensor body from the cap.
2. Attach the body to the wall using the screws/anchors provided with the device.
3. Run the wires into the device body through the grommet opening.
4. Connect the wires to the terminal block.
5. Attach the cap to the body.



Navien Outdoor Temperature Sensor

Outdoor Temperature Sensor Installation Guidelines

- Avoid areas with temperature fluctuations by direct sunlight, and where the temperature may not be representative of true outdoor temperature.
- Best location to install the temperature sensor is on a North or Northeast side of a structure under eaves where the sensor is shielded from direct sunlight.
- Avoid placing sensor in close proximity of heat sources that may affect correct temperature sensing. (fans, exhausts, flues, lights)
- Avoid installing the sensor in areas where the sensor is subjected to excessive moisture.
- Use 18 gauge wiring (thermostat wiring) with no splices. (except at the unit harness connection with yellow leader wire.)
- Caution should be taken to avoid potential electromagnetic interference (EMI) by routing separately from potential sources such as line voltage wiring. When necessary, shielded cable may be used.
- Make sure wiring connections are secure before closing the cap.
- The sensor is a water resistant device.
- Any damage to the device may require the replacement of the entire component.

GAS BOILER SYSTEM COMMISSIONING CHECKLIST

This Commissioning Checklist is to be completed in full by the competent person who commissioned the boiler as a means of demonstrating compliance with the appropriate Building Regulations and then handed to the customer to keep for future reference.

Failure to install and commission according to the manufacturer's instructions and complete this Benchmark Commissioning Checklist will invalidate the warranty. This does not affect the customer's statutory rights.

Customer name:				Telephone number:				
Address:								
Boiler make and model:								
Boiler serial number:								
Commissioned by (PRINT NAME):				Gas Safe register number:				
Company name:				Telephone number:				
Company address:								
Commissioning date:								
To be completed by the customer on receipt of a Building Regulations Compliance Certificate*								
Building Regulations Notification Number (if applicable):								
CONTROLS (tick the appropriate boxes)								
Time and temperature control to heating	Room thermostat and programmer/timer		Programmable room thermostat					
	Load/weather compensation		Optimum start control					
Time and temperature control to hot water	Cylinder thermostat and programmer/timer		Combination Boiler					
Heating zone valves	Fitted		Not required					
Hot water zone valves	Fitted		Not required					
Thermostatic radiator valves	Fitted		Not required					
Automatic bypass to system	Fitted		Not required					
Boiler interlock			Provided					
ALL SYSTEMS								
The system has been flushed and cleaned in accordance with BS7593 and boiler manufacturer's instructions							Yes	
What system cleaner was used?								
What inhibitor was used?							Quantity	litres
Has a primary water system filter been installed?							Yes	No
CENTRAL HEATING MODE measure and record:								
Gas rate	m ³ /hr	OR	ft ³ /hr					
Burner operating pressure (if applicable)	mbar	OR Gas inlet pressure	mbar					
Central heating flow temperature			°C					
Central heating return temperature			°C					
COMBINATION BOILERS ONLY								
Is the installation in a hard water area (above 200ppm)?							Yes	No
If yes, and if required by the manufacturer, has a water scale reducer been fitted?							Yes	No
What type of scale reducer has been fitted?								
DOMESTIC HOT WATER MODE Measure and Record:								
Gas rate	m ³ /hr	OR	ft ³ /hr					
Burner operating pressure (at maximum rate)	mbar	OR Gas inlet pressure at maximum rate	mbar					
Cold water inlet temperature			°C					
Hot water has been checked at all outlets		Yes	Temperature	°C				
Water flow rate			l/min					
CONDENSING BOILERS ONLY								
The condensate drain has been installed in accordance with the manufacturer's instructions and/or BS5546/BS6798							Yes	
ALL INSTALLATIONS								
Record the following:	At max. rate:	CO	ppm	AND	CO/CO ₂	Ratio		
	At min. rate: (where possible)	CO	ppm	AND	CO/CO ₂	Ratio		
The heating and hot water system complies with the appropriate Building Regulations							Yes	
The boiler and associated products have been installed and commissioned in accordance with the manufacturer's instructions							Yes	
The operation of the boiler and system controls have been demonstrated to and understood by the customer							Yes	
The manufacturer's literature, including Benchmark Checklist and Service Record, has been explained and left with the customer							Yes	
Commissioning Engineer's Signature								
Customer's Signature								
(To confirm satisfactory demonstration and receipt of manufacturer's literature)								

*All installations in England and Wales must be notified to Local Authority Building Control (LABC) either directly or through a Competent Persons Scheme. A Building Regulations Compliance Certificate will then be issued to the customer.



SERVICE RECORD

It is recommended that your heating system is serviced regularly and that the appropriate Service Interval Record is completed.

Service Provider

Before completing the appropriate Service Record below, please ensure you have carried out the service as described in the manufacturer's instructions. Always use the manufacturer's specified spare part when replacing controls.

SERVICE 01					Date:
Engineer name:					
Company name:					
Telephone No:					
Gas safe register No:					
Record:	At max. rate:	CO	ppm	AND	CO ₂ %
	At min. rate: (Where Possible)	CO	ppm	AND	CO ₂ %
Comments:					
Signature					

SERVICE 02					Date:
Engineer name:					
Company name:					
Telephone No:					
Gas safe register No:					
Record:	At max. rate:	CO	ppm	AND	CO ₂ %
	At min. rate: (Where Possible)	CO	ppm	AND	CO ₂ %
Comments:					
Signature					

SERVICE 03					Date:
Engineer name:					
Company name:					
Telephone No:					
Gas safe register No:					
Record:	At max. rate:	CO	ppm	AND	CO ₂ %
	At min. rate: (Where Possible)	CO	ppm	AND	CO ₂ %
Comments:					
Signature					

SERVICE 04					Date:
Engineer name:					
Company name:					
Telephone No:					
Gas safe register No:					
Record:	At max. rate:	CO	ppm	AND	CO ₂ %
	At min. rate: (Where Possible)	CO	ppm	AND	CO ₂ %
Comments:					
Signature					

SERVICE 05					Date:
Engineer name:					
Company name:					
Telephone No:					
Gas safe register No:					
Record:	At max. rate:	CO	ppm	AND	CO ₂ %
	At min. rate: (Where Possible)	CO	ppm	AND	CO ₂ %
Comments:					
Signature					

SERVICE 06					Date:
Engineer name:					
Company name:					
Telephone No:					
Gas safe register No:					
Record:	At max. rate:	CO	ppm	AND	CO ₂ %
	At min. rate: (Where Possible)	CO	ppm	AND	CO ₂ %
Comments:					
Signature					

SERVICE 07					Date:
Engineer name:					
Company name:					
Telephone No:					
Gas safe register No:					
Record:	At max. rate:	CO	ppm	AND	CO ₂ %
	At min. rate: (Where Possible)	CO	ppm	AND	CO ₂ %
Comments:					
Signature					

SERVICE 08					Date:
Engineer name:					
Company name:					
Telephone No:					
Gas safe register No:					
Record:	At max. rate:	CO	ppm	AND	CO ₂ %
	At min. rate: (Where Possible)	CO	ppm	AND	CO ₂ %
Comments:					
Signature					

SERVICE 09					Date:
Engineer name:					
Company name:					
Telephone No:					
Gas safe register No:					
Record:	At max. rate:	CO	ppm	AND	CO ₂ %
	At min. rate: (Where Possible)	CO	ppm	AND	CO ₂ %
Comments:					
Signature					

SERVICE 10					Date:
Engineer name:					
Company name:					
Telephone No:					
Gas safe register No:					
Record:	At max. rate:	CO	ppm	AND	CO ₂ %
	At min. rate: (Where Possible)	CO	ppm	AND	CO ₂ %
Comments:					
Signature					

*All installations in England and Wales must be notified to Local Authority Building Control (LABC) either directly or through a Competent Persons Scheme. A Building Regulations Compliance Certificate will then be issued to the customer.



Memo

Memo

Memo
