

MURELLE EQUIPE 70 ErP

(PACK OF 2 MURELLE HE 35 R ErP)

INSTALLATION AND SERVICING INSTRUCTIONS

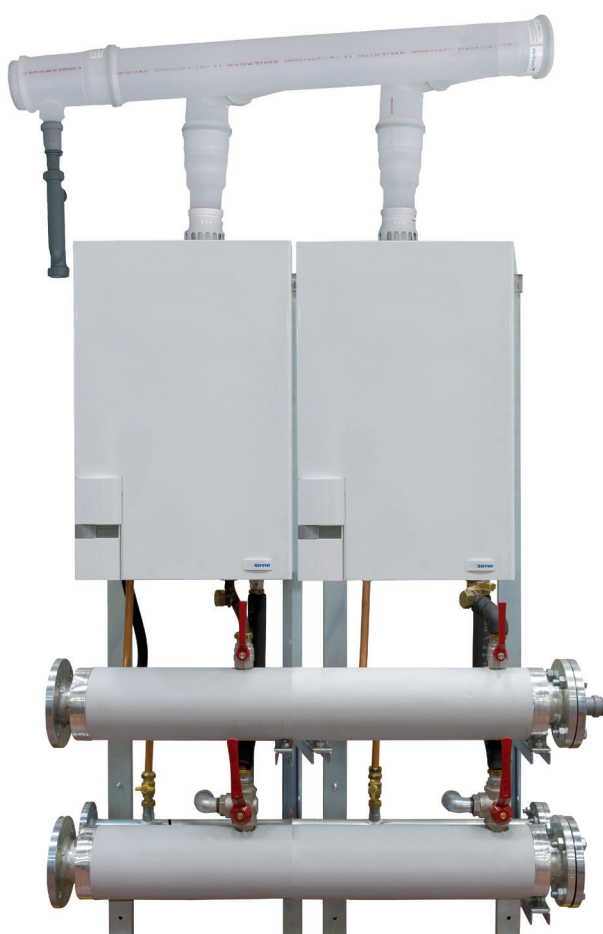

ENSURE THAT THESE INSTRUCTIONS ARE LEFT FOR THE USER AFTER COMPLETION OF THE BENCHMARK SECTION

PLEASE READ THE IMPORTANT NOTICE WITHIN THIS GUIDE REGARDING YOUR BOILER WARRANTY



199839

ORIGINAL INSTRUCTIONS

SAFE HANDLING

This boiler may require 2 or more operatives to move it into its installation site, remove it from its packaging and during movement into its installation location. Manoeuvring the boiler may include the use of a sack truck and involve lifting pushing and pulling.

Caution should be exercised during these operations.

Operatives should be knowledgeable in handling techniques when performing these tasks and the following precautions should be considered:

- Grip the boiler at the base
- Be physically capable
- Use personal protective equipment as appropriate e.g. gloves, safety footwear.

During all manoeuvres and handling actions, every attempt should be made to ensure the following unless unavoidable and/or the weight is light.

- Keep back straight
- Avoid twisting at the waist
- Always grip with the palm of the hand
- Keep load as close to the body as possible
- Always use assistance

WARNING

Caution should be exercised when performing any work on this appliance.

Protective gloves and safety glasses are recommended.

- Avoid direct contact with sharp edges.
- Avoid contact with any hot surfaces.

NOTICE

Please be aware that due to the wet testing of the appliance, there may be some residual water in the hydraulic circuit.

- Protect any surfaces, carpets or floorings.
- Use a suitable container to catch any water that escapes when removing the protective caps from the connections.



CONTENTS

1	DESCRIPTION	pag.	4
2	ASSEMBLING THE BOILER SUPPORT FRAME	pag.	13
3	JUNCTION CONNECTIONS AND CONDENSATION DRAIN MANIFOLD	pag.	14
4	CASCADE FLUE	pag.	18
5	CASCADE CONNECTION	pag.	19
6	CASCADE MANAGEMENT	pag.	20
7	APPENDIX (GUIDANCE HHIC)	pag.	25
8	APPENDIX 2 (VENTILATION GUIDENCE)	pag.	39
9	PRODUCT DETAILS.....	pag.	40
10	ANNEX AA.1	pag.	41

Important Information

IT IS A STATUTORY REQUIREMENT THAT ALL GAS APPLIANCES ARE INSTALLED BY COMPETENT PERSONS, IN ACCORDANCE WITH THE GAS SAFETY (INSTALLATION AND USE) REGULATIONS (CURRENT EDITION). The manufacturer's instructions must not be taken as overriding any statutory requirements, and failure to comply with these regulations may lead to prosecution.

No modifications to the appliance should be made unless they are fully approved by the manufacturer.

GAS LEAKS: DO NOT OPERATE ANY ELECTRICAL SWITCH, OR USE A NAKED FLAME. TURN OFF THE GAS SUPPLY AND VENTILATE THE AREA BY OPENING DOORS AND WINDOWS contact the gas emergency service on 0800111999.

Please refer to commissioning instructions for filling in the checklist at the back of this installation guide.

Note: All Gas Safe registered installers carry a ID Card.

You can check your installer is Gas Safe Registered by calling 0800 408 5577

IMPORTANT

Prior to switching on the boiler for the first time, check the following:

- Make sure that there are no liquids or inflammable materials in the immediate vicinity of the boiler.
- Make sure that the electrical connections have been made correctly and that the earth wire is connected to a good earthing system.
- Ensure that tightness and let by test have been conducted, including the internal gas pipe work.
- Make sure that the boiler is set for operation for the type of gas supplied.
- Check that the flue pipe for the outlet of the products of the combustion is unobstructed and has been properly installed.
- Make sure that any isolation valves are open.
- Make sure that the system is filled with water and is thoroughly vented.
- Check that the circulating pump is not jammed.
- Purge the gas supply pipe work.
- Ensure that the checklist is filled in when the commissioning has been completed.

All descriptions and illustrations provided in this manual have been carefully prepared but we reserve the right to make changes and improvements in our products that may affect the accuracy of the information contained in this manual.

1 DESCRIPTION

1.1 INTRODUCTION

This manual is for the construction maintenance and operation of a modular unit composed of multiple premixed condensation boilers in the **MURELLE EQUIPE 70 ErP** series linked in sequence/cascade independently of one another. The package **MURELLE EQUIPE 70 ErP**

- code 8113111 is provided with:
- 2 boilers **MURELLE HE 35 R ErP** code 8113101
 - 1 accessories group code 5193611
 - 2 fume exhaust manifold code 5192850
 - 2 extension for fume exhaust manifold code 6296539
 - 1 fume exhaust manifold closing code 5192960

Hydraulic manifold connection kit code 8101535 and the hydraulic compensator code 8101556. The assembly of the kits is **MANDATORY**.

VENTILATION,
for guidance see **APPENDIX 2**.

1.2 DIMENSIONS (fig. 1)

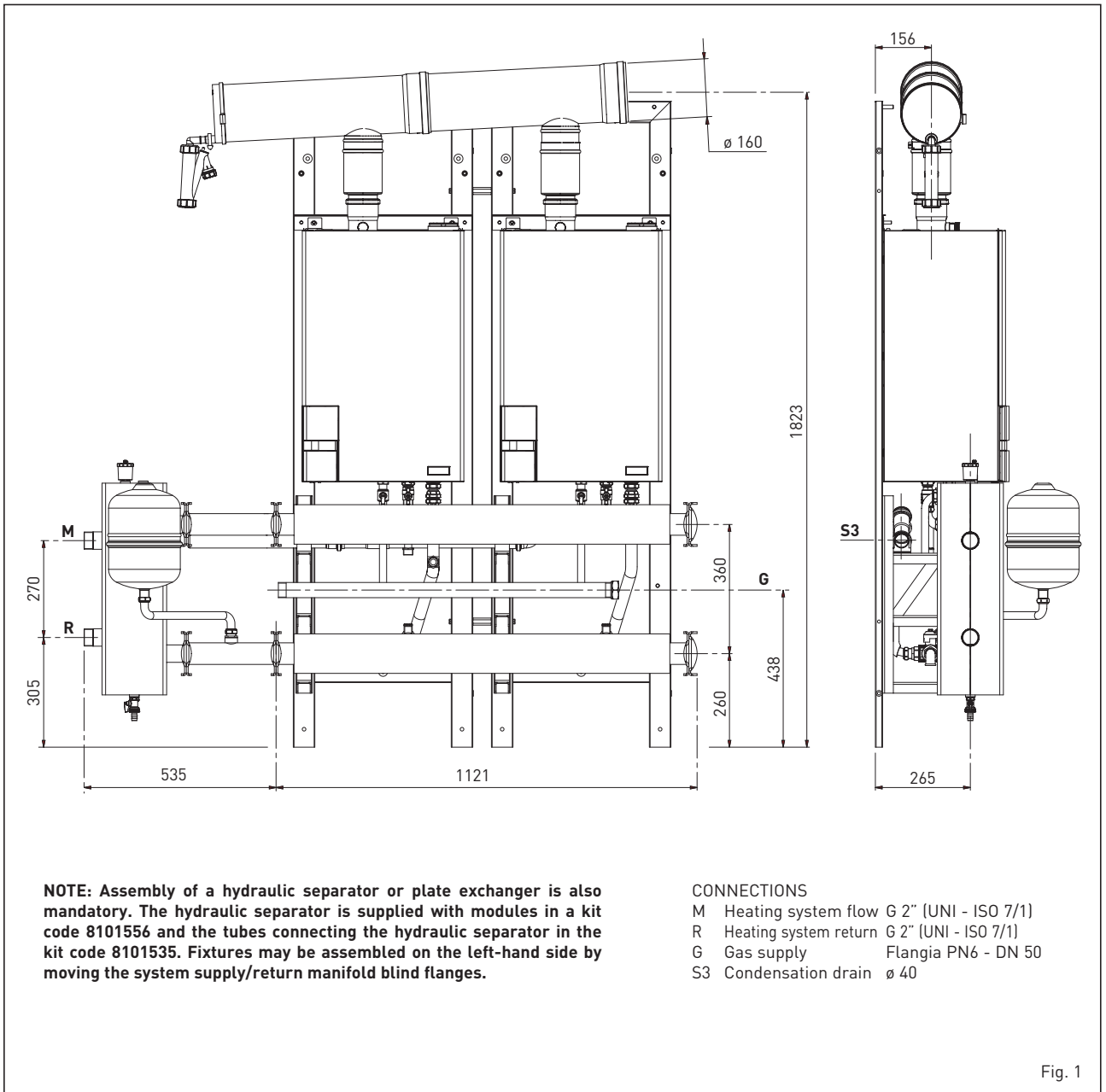

Fig. 1

1.3 TECHNICAL DATA

MURELLE EQUIPE 70 ErP		
Heating units MURELLE HE 35 R ErP	n°	2
Heat output		
Nominal (80-60°C) (Pn max)	kW	67.6 [2 x 33.8]
Nominal (50-30°C) (Pn max)	kW	74.4 [2 x 37.2]
Min G20/G31 (80-60°C) (Pn min)	kW	3.2/5.5
Min G20/G31 (50-30°C) (Pn min)	kW	3.7/6.4
Heat input (*)		
Nominal (Qn max - Qnw max)	kW	69.6 [2 x 34.8]
Min G20/G31 (Qn min - Qnw min)	kW	3.48/6.0
Min/max useable yield (80-60°C)	%	92.0/97.2
Min/max useable yield (50-30°C)	%	106.3/106.8
Useful yield at 30% (40-30°C)	%	108.6
Losses to arrest to 50°C (EN 15502)	W	216 [2 x 108]
Electrical supply and frequency		
	V-Hz	230-50
Power absorbed (Qn max)	W	216 [2 x 108]
Power absorbed (Qn min)	W	70
Power absorbed pump high efficiency	W	90 [2 x 45]
Degree of electric protection		IP X4D
Energy efficiency		
Seasonal energy efficiency class of the heating system		A
Seasonal energy efficiency of the heating system	%	93
Sound power of the heating system	dB (A)	58
Setting range single module	°C	20/80
Water content of modules	l	10.8
Max. operating pressure (PMS)	bar (kPa)	3.5 [343]
Max. operating temperature (T max)	°C	85
Flue gas temperature at Nominal capacity (80-60°C)	°C	70
Flue gas temperature at Minimum capacity (80-60°C)	°C	60
Flue gas temperature at Nominal capacity (50-30°C)	°C	40
Flue gas temperature at Minimum capacity (50-30°C)	°C	33
Min/max flow rate of flue gases	g/s	1.7/32.8
CO2 at Minimum/Nominal capacity (G20)	%	8.4/9.3
CO2 at Minimum/Nominal capacity (G31)	%	10.0/10.2
NOx measured (EN 15502 - 1:2015)	mg/kWh	26
Max. pressure at flue gas release manifold	Pa	180
PIN number		1312CM5360
Category		II2H3P
Type		B23P-B53P-C13-C33-C43-C53-C83
NOx emission class (EN 15502 - 1:2015)		6 (< 56 mg/kWh)
Main gas nozzles single module		
Number of nozzles	n°	2
Nozzle diameter (G20)	ø mm	3.5/4.0
Nozzle diameter (G31)	ø mm	2.8/3.0
Consumption at nominal/min. power		
Nominal (G20)	m ³ st/h	7.36 [2 x 3.68]
Minimum (G20)	m ³ st/h	0.39
Nominal (G31)	kg/h	5.40 [2 x 2.70]
Minimum (G31)	kg/h	0.46
Gas supply pressure		
(G20)	mbar (kPa)	20 [1.96]
(G31 - Propane)	mbar (kPa)	37 [3.63]

(*) Heat input of the heating system measured using lower heating value (LHV)

1.4 HYDRAULIC CIRCUIT (fig. 2)

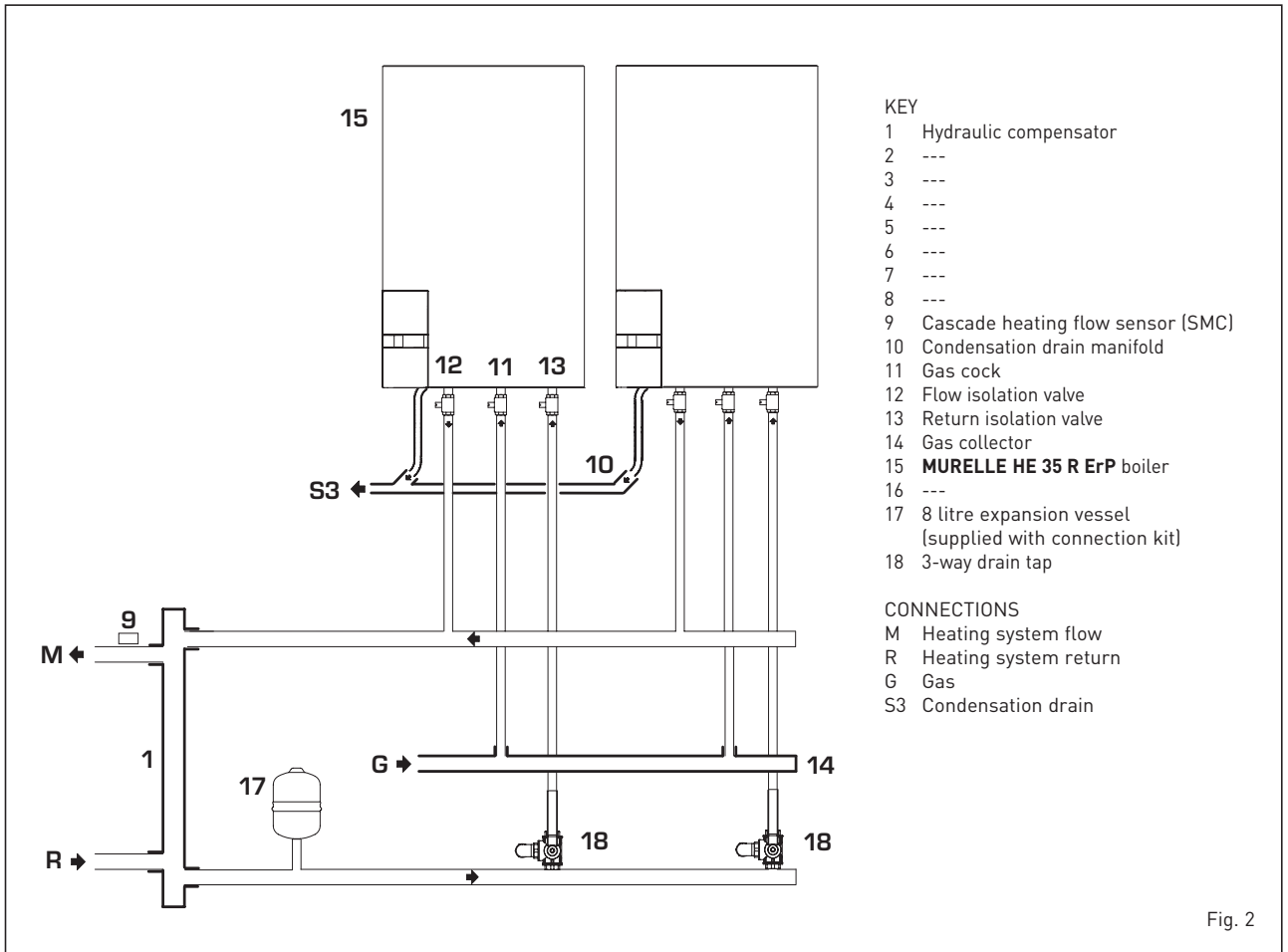

1.5 LOAD LOSS IN HYDRAULIC SEPARATOR SUPPLIED UPON REQUEST IN KITS CODE 8101550 (fig. 3)

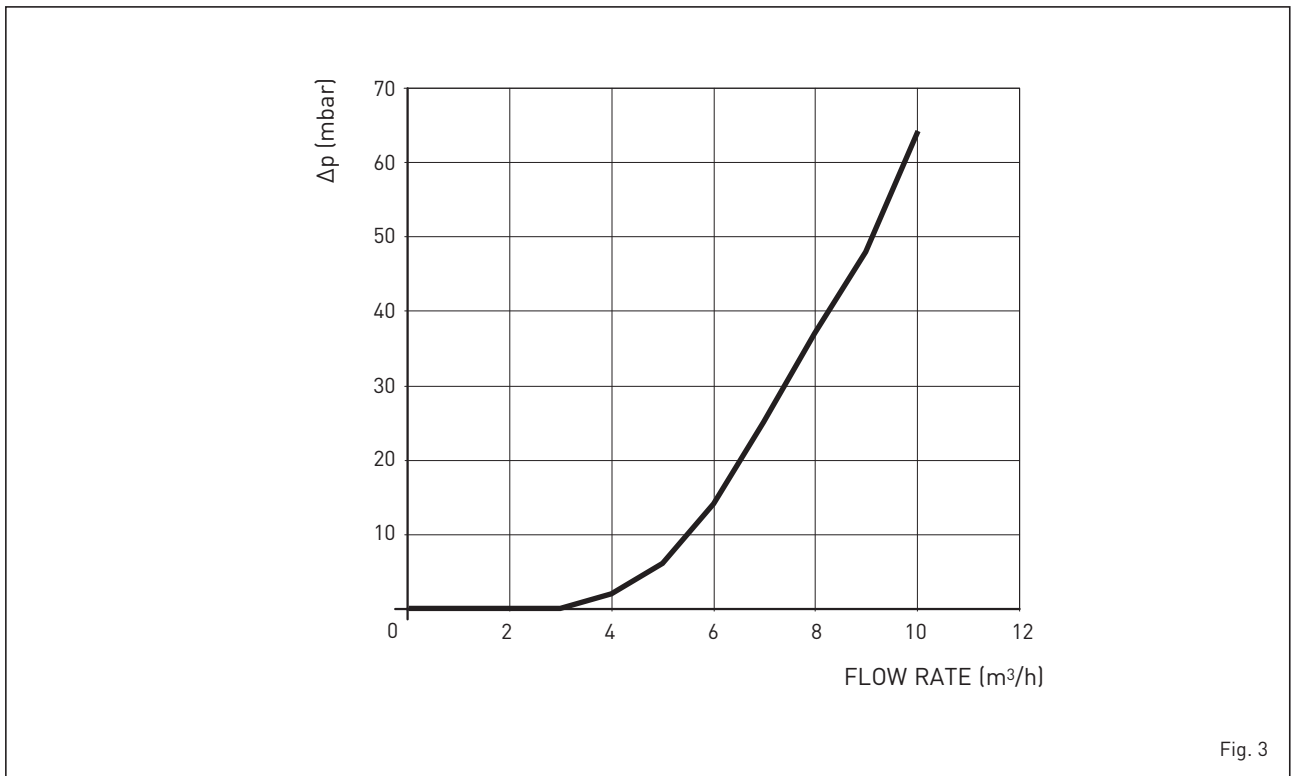

1.6 TECHNICAL DATA PLATE (fig. 3/a)

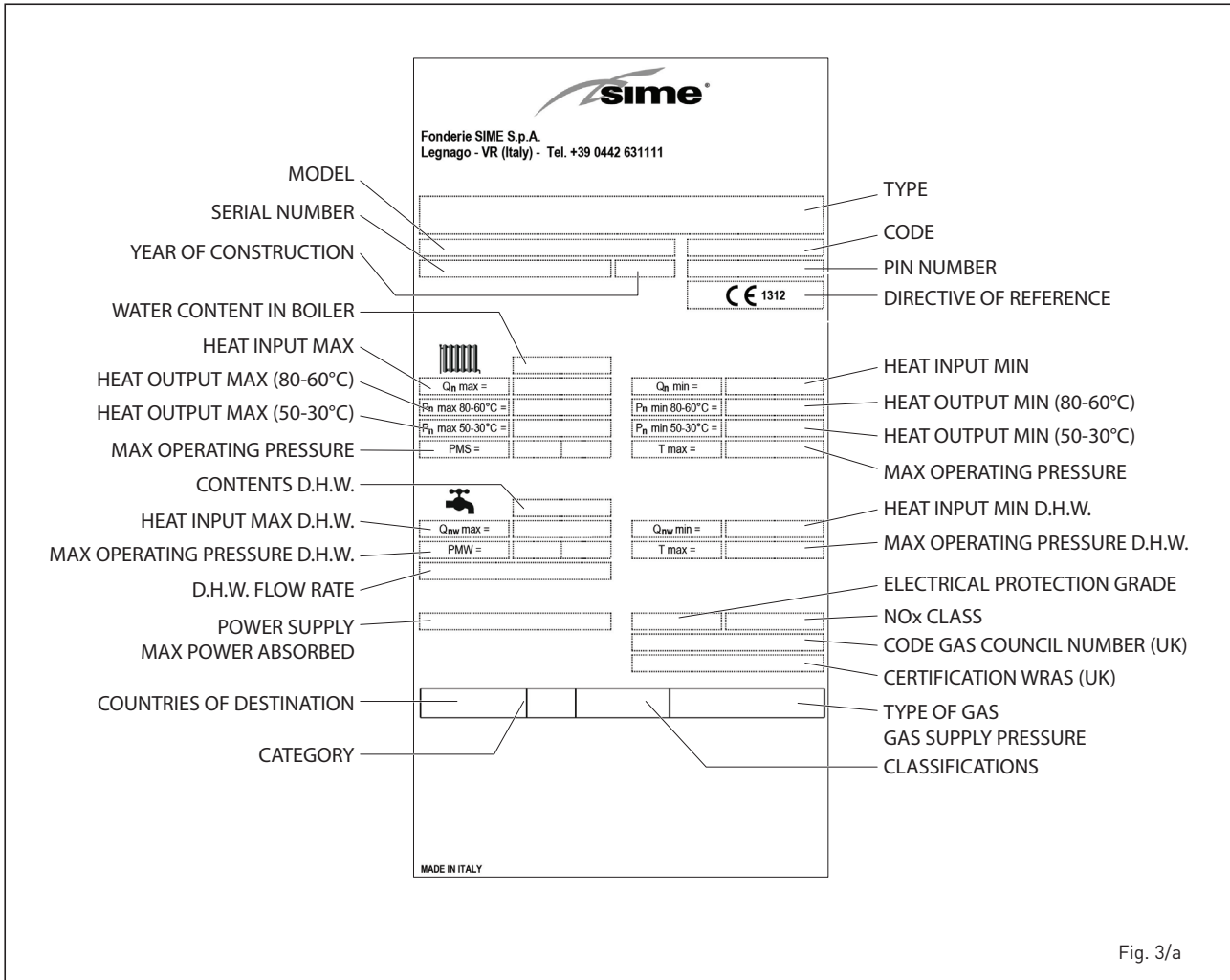

Fig. 3/a

1.7 INTERFACE WITH OTHER ELECTRONIC DEVICES OPTIONAL

The electronic boiler board is prepared for the application of the following electronic devices to be requested separately:

- Remote control SIME HOME code 8092281
- thermoregulator RVS code 8092255

- MIXED ZONE kit code 8092252
- INSOL kit code 8092254
- RS-485 kit code 8092244 which allows to MODBUS communication cascade boilers
- Additional casing board code 8092236 when you connect MIXED ZONE or INSOL board.

All devices are supplied with instructions

for installation and use.

For the configuration of devices SIME HOME e RVS with electronic boiler board set **PAR 10**.

To access the installer parameters see section **6 (RS-485 board for cascade management)**.

1.8 CONTENTS OF KIT (code 5193611) (fig. 4)

- N° 2 frame kit code 6294800 with screws TE M8 x 75

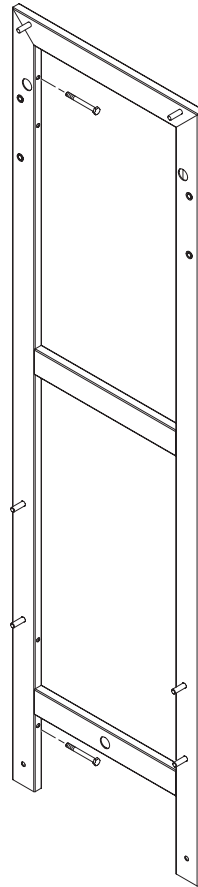

Fig. 4/a

- N° 2 support brackets boiler code 6073324 with screws TE M8 x 16

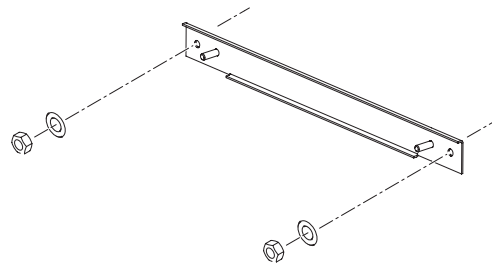

Fig. 4/b

- N° 2 shelf kit code 6294812 with washers and nuts M10.

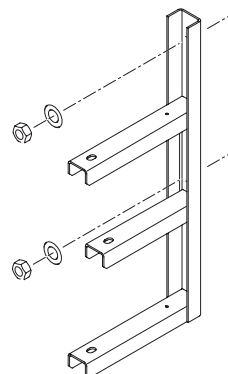

Fig. 4/c

- N° 2 flow/return manifold kit code 6291958 coated in polyurethane with flanges, seal and M12 fixing screws

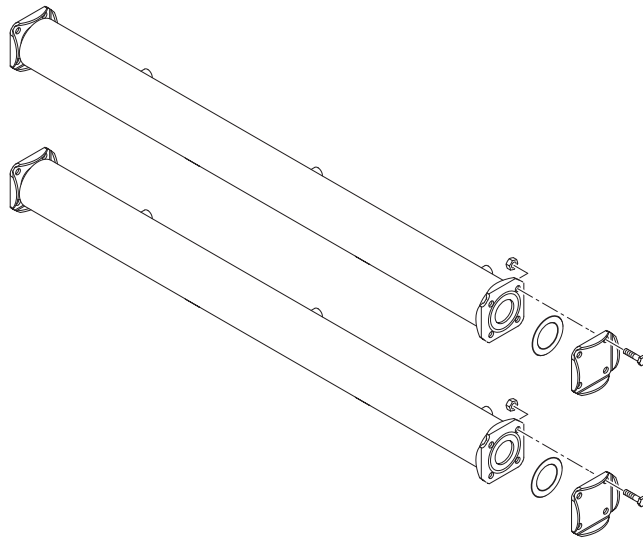

Fig. 4/d

- N° 1 gas collector code 6286312 with nuts, M12 fixing screws and flange

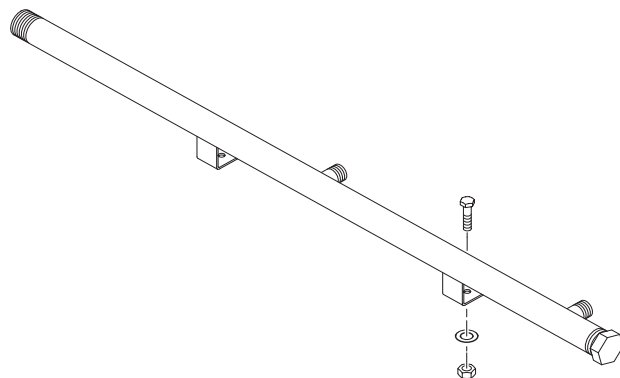

Fig. 4/e

- N° 1 condensation drain manifold code 5193002. The manifold is supplied with brackets, nuts and M8 screws

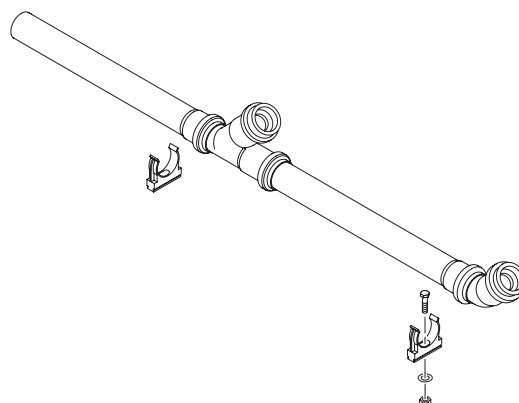
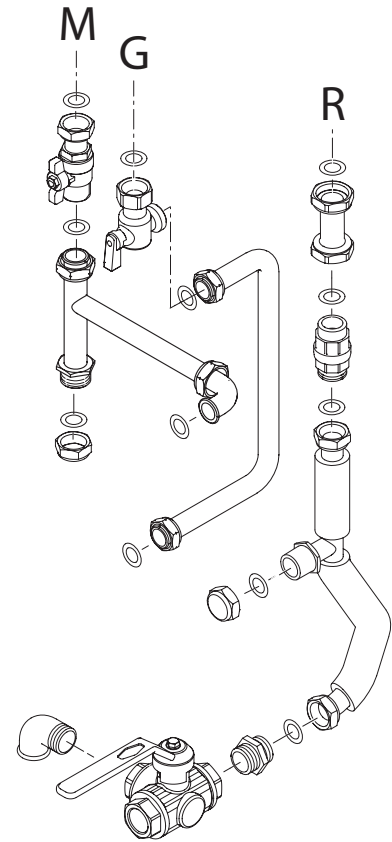
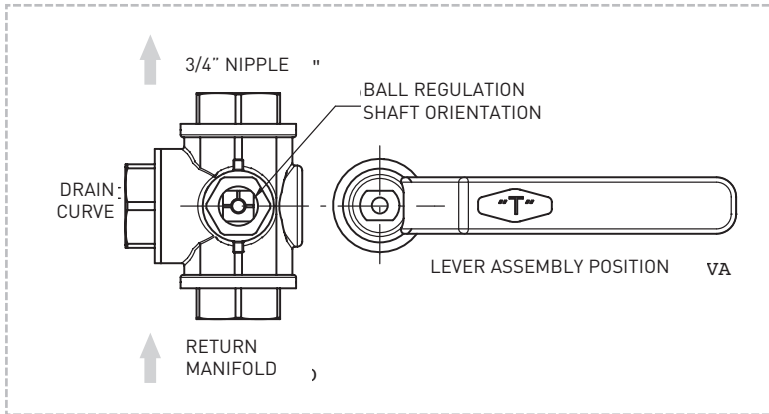

Fig. 4/f

- N° 2 three-way flow/return and gas cock kits, connecting pipes, 3/4" nipple, non-return valve and seals for the connection of two modules **MURELLE EQUIPE 70 ErP**.

CAUTION: Before assembling three-way drain valve, orient the ball regulation lever as shown in the figure.



- M Heating system flow
- R Heating system return
- G Gas supply

Fig. 4/g

- N° 1 sensor kit code 8092250 with external sensor (SE), cascade heating flow sensor (SMC) and RS-485 board connection cable.

NOTE: Section 5 show the electrical connection for the sensors.

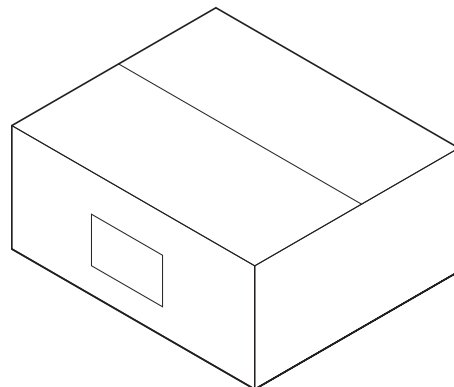
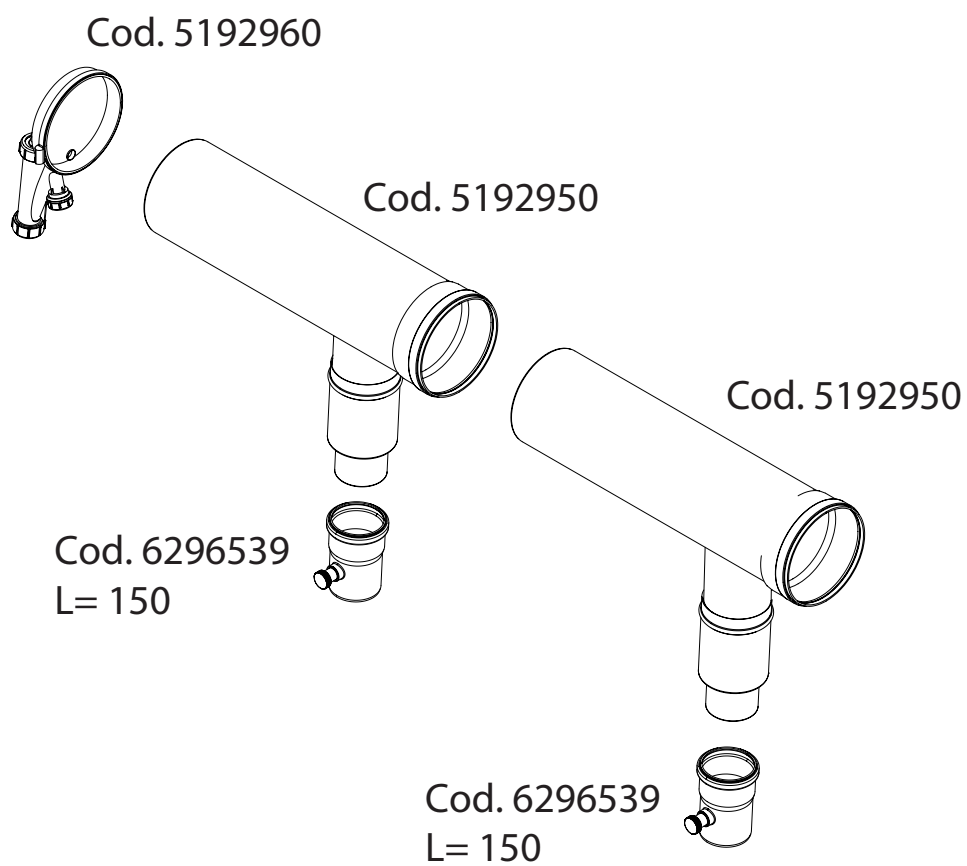

Fig. 4/h

1.9 COMPOSITION KIT MANIFOLD EXHAUST (fig. 5)



- Kit manifold exhaust is composed of:
- N. 2 pipe \varnothing 160 code 5192950
- N. 2 extension L. 150 \varnothing 80 code 6296539
- N. 1 manifold tap code 5192960.

CAUTION: Use silicone grease to ease the connection of the flue components.

Fig. 5

1.10 LOW LOSS HEADER CONNECTION KIT code 8101535 (order separately) (fig. 6)

- N° 2 flanged heating system flow/return stub pipes complete with expansion vessel 8 liters code 6245108, connection pipe code 6227661, gaskets and nipple.

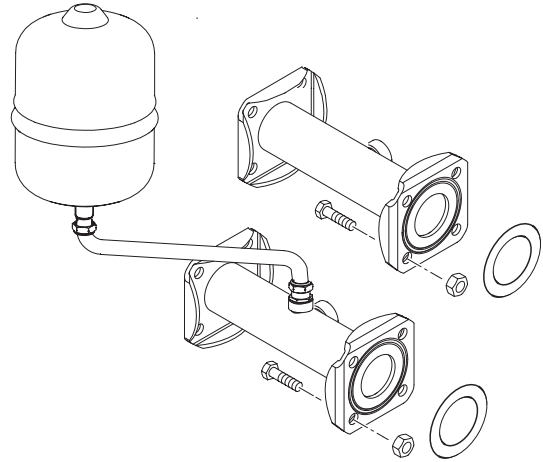

Fig. 6

1.11 LOW LOSS HEADER code 8101556 (order separately) (fig. 7)

- N° 1 Hydraulic separator with seals, nuts and M12 screws.

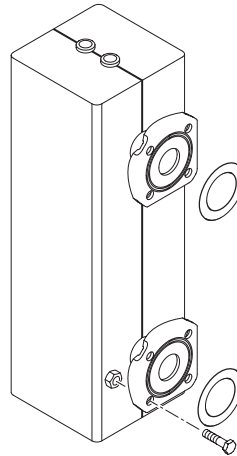
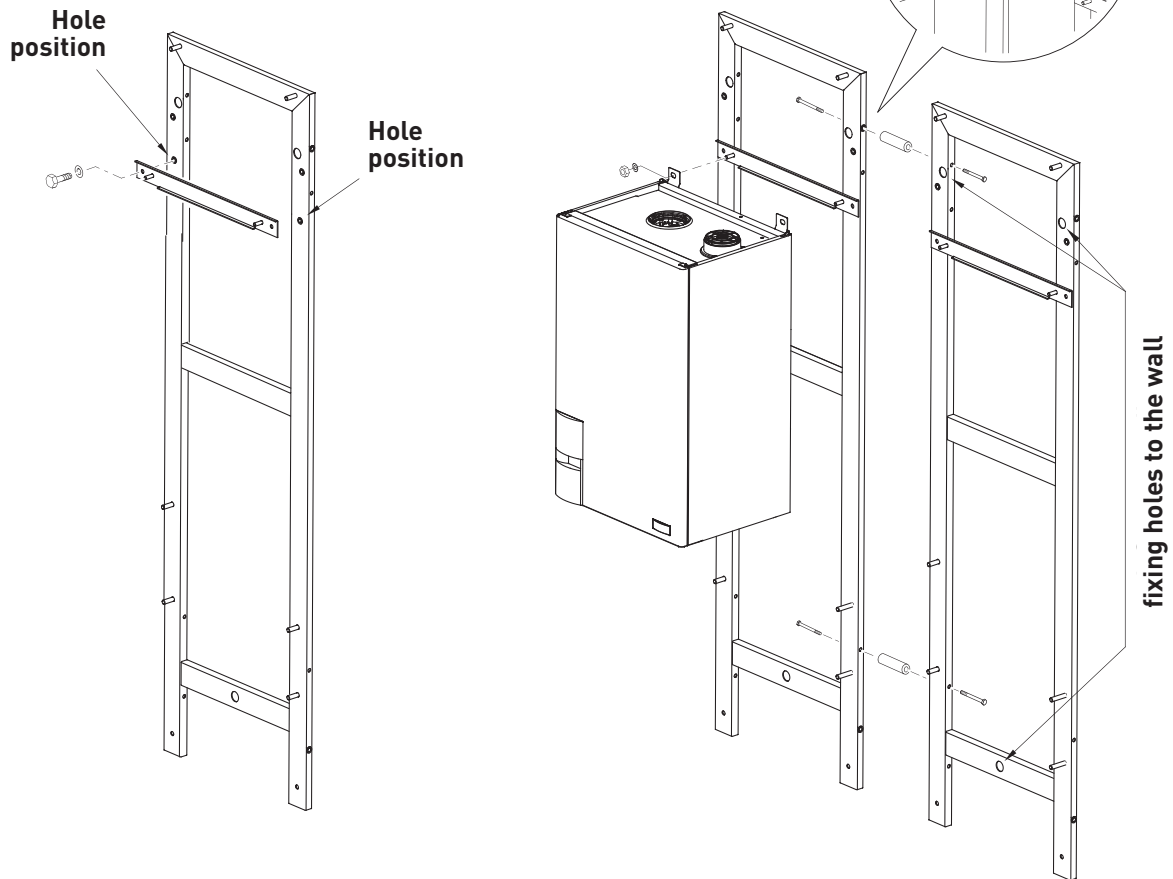

Fig. 7

2 ASSEMBLING THE BOILER SUPPORT FRAME

- 1** Screw support brackets boiler to the boiler support frame with washer and M8 screws. Alongside the supporting frames of each module and locking them together with TE M8 x 75 screws. Secure the assembled frames to the wall or other secure structure. Attach each module **MURELLE HE 35 R ErP** to the boiler support frame and fix with washer and M10 nuts.



- 2** Fix the two shelf brackets to boiler support frame with four washers and M10 nuts.

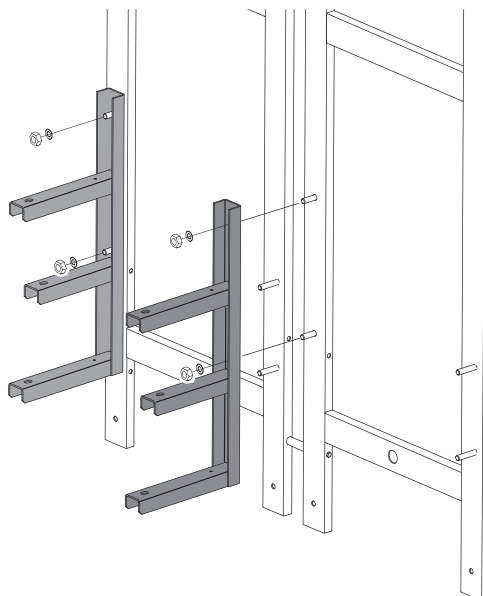

3 FITTING CONNECTIONS AND CONDENSATE DRAIN

- 1 Mount the condensation drain manifold brackets with screws, washer and M5 nuts. Insert the condensation drain manifold in those brackets. Connect the each condensate boiler drain trap to the condensation drain manifold.

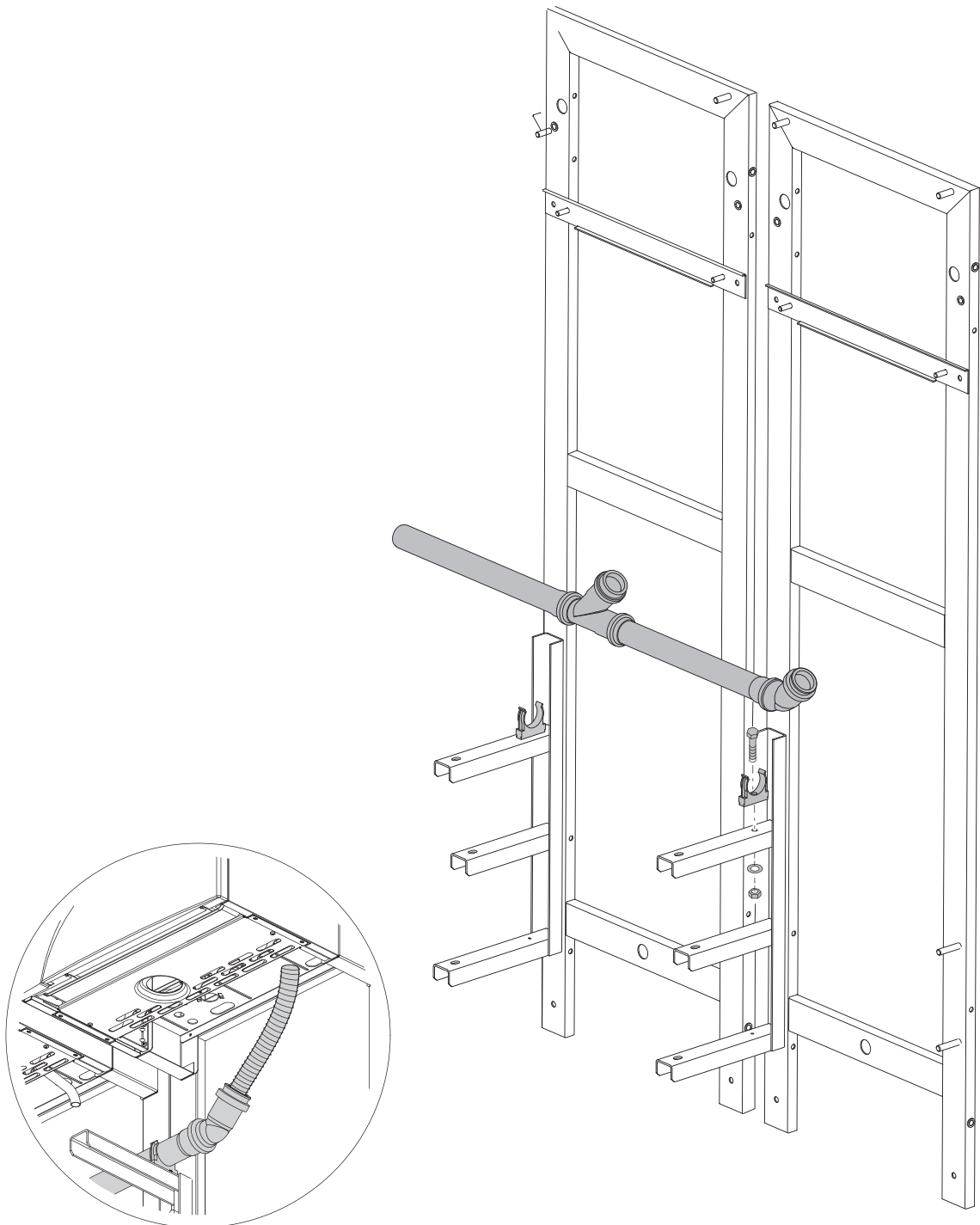

- 2** Assemble the blank flange with gas gasket to manifold with screws and M12 nuts. Secure the gas header with screws, washers and M8 nuts.

CAUTION: The fuel shut-off valve is not provided.

- 3** Install blind flanges with gaskets to flow/return manifold with screws and M12 nuts. Fix the flow/return manifold in its support with screws, washers and M8 nuts.

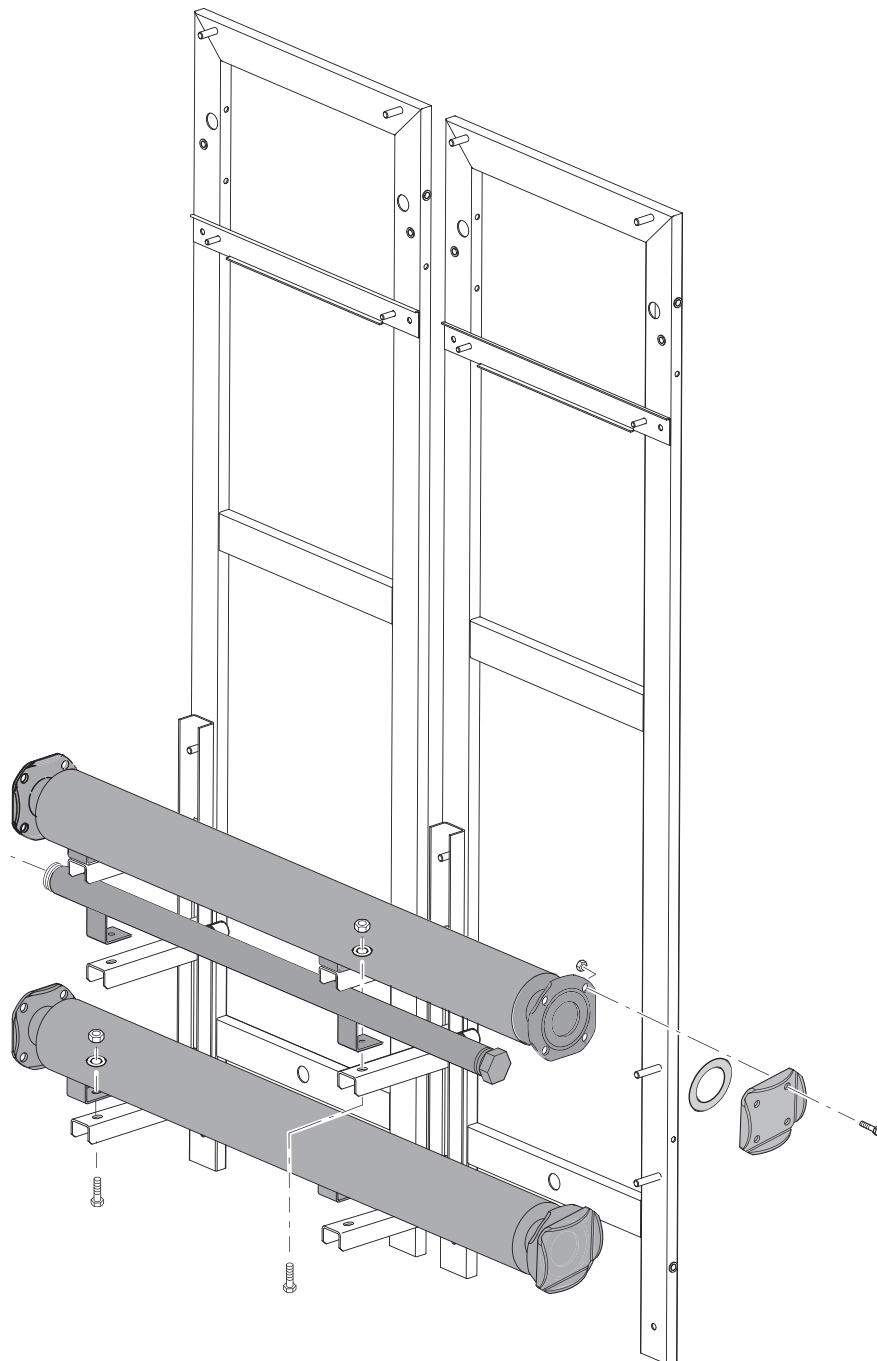

4

- Install:
- three-way flow/return valve
 - gas cock
 - non-return valve

to the respective manifolds and install the pipes to the connections of the boiler with the respective seals.

CAUTION: Before assembling three-way drain valve, orient the ball regulation lever as shown in the figure.

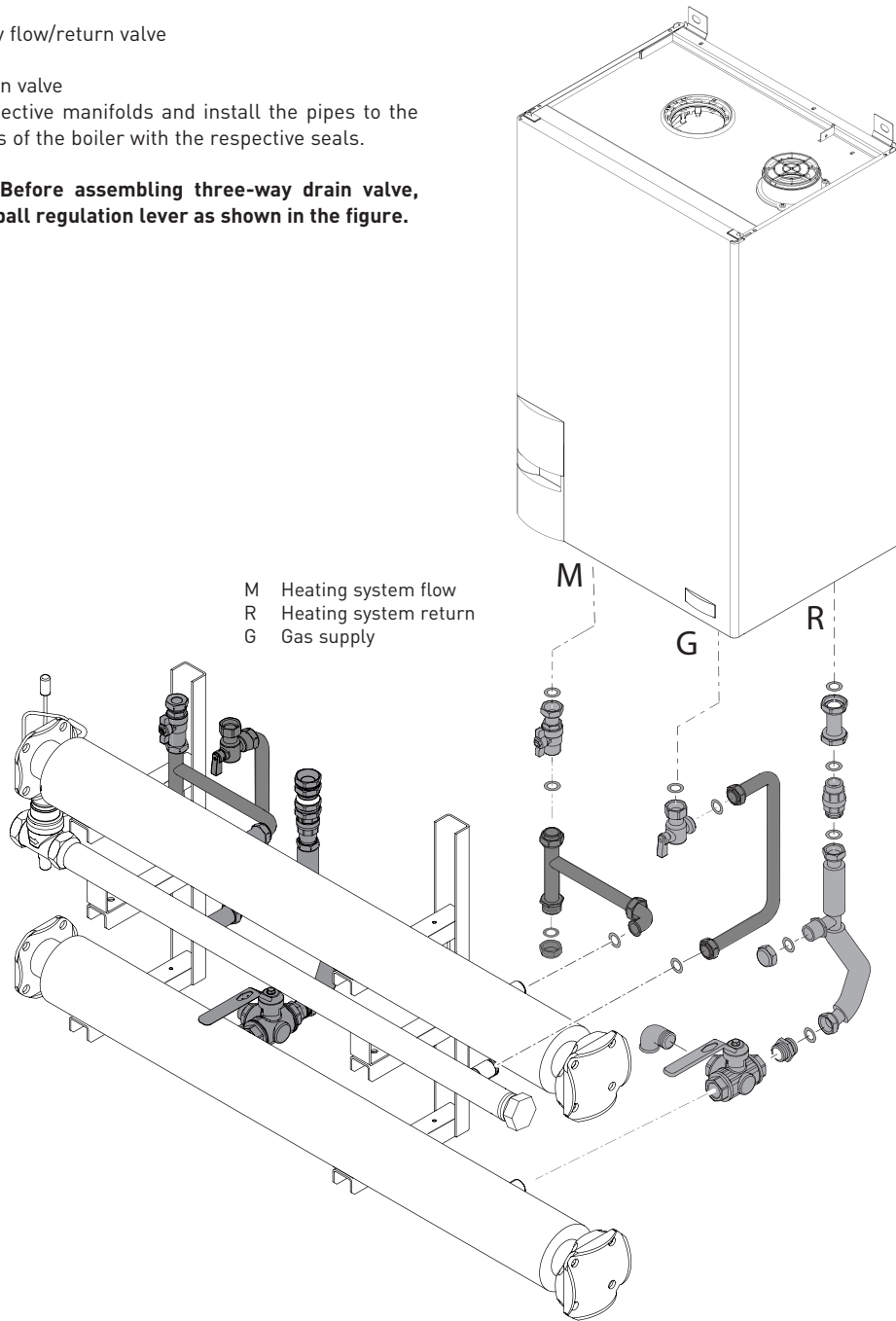

M Heating system flow
R Heating system return
G Gas supply

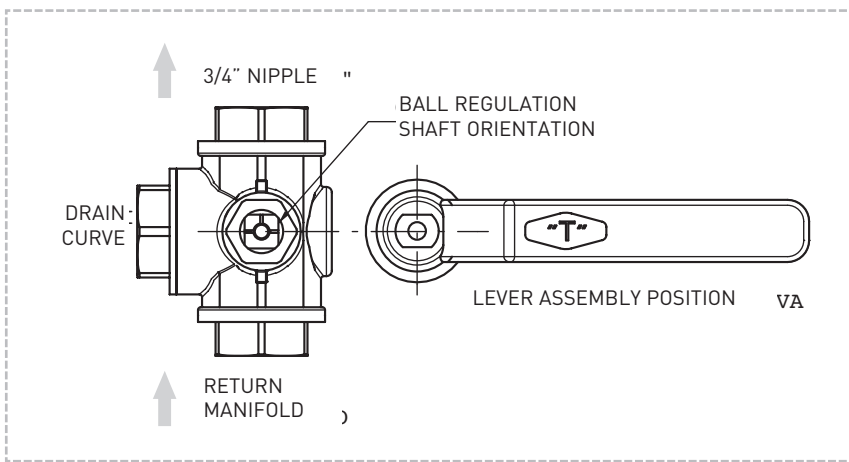

5

Connection of the hydraulic separator, if supplied.
Assemble with seals and M12 fixing screws and nuts.

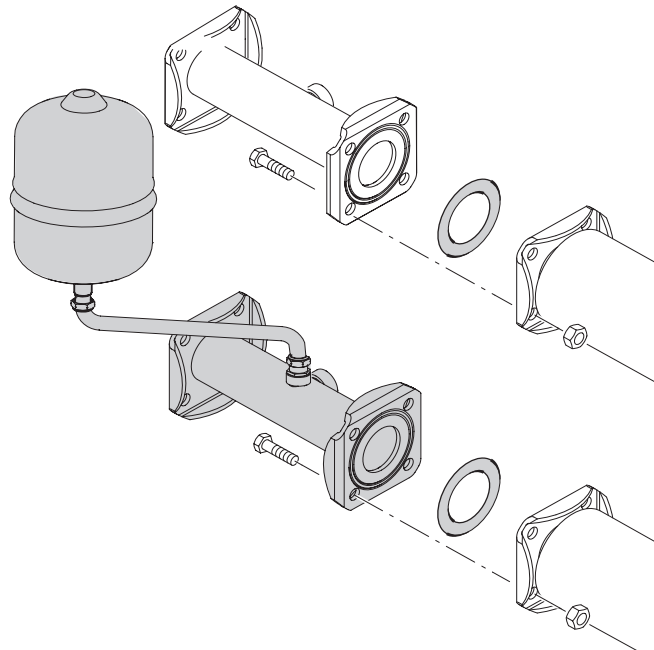

6

Connection of the hydraulic separator, if supplied.
Assemble with seals and M12 fixing screws and nuts.

CAUTION: Assemble the air vent valve, the drain valve and sleeve 1/2" (not supplied) in the position as shown in figure.

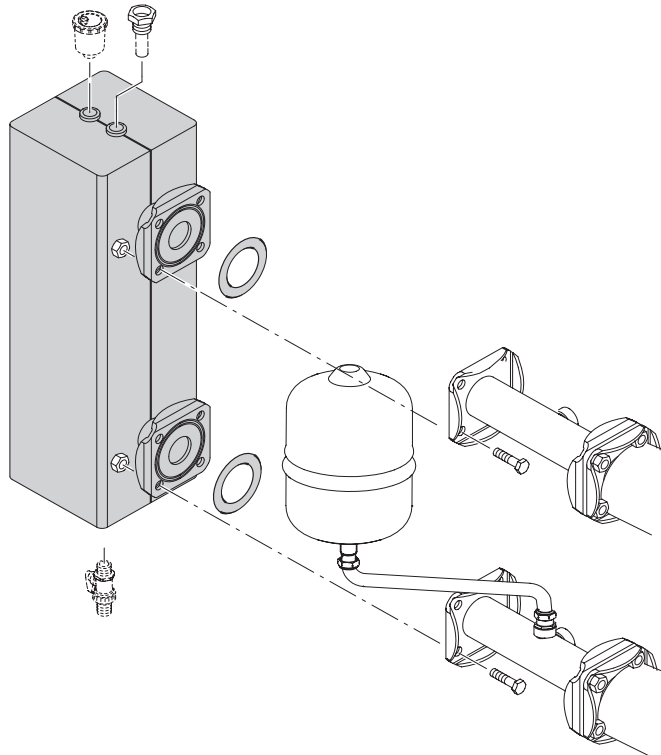

4 CASCADE FLUE

- Assemble the cascade flue as shown. use silicone grease to ease connection of the components
The flue can be orientated to the left or the right, but always must fall to the condensate drain.

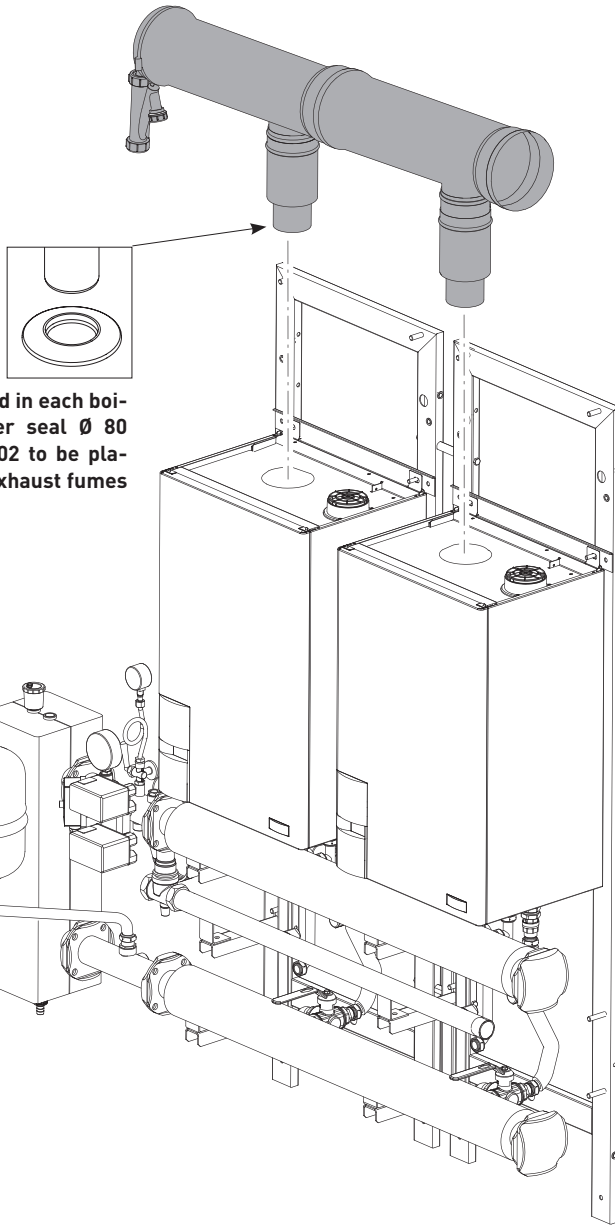

It is provided in each boiler a rubber seal \varnothing 80 code 6230402 to be placed in the exhaust fumes as shown.

When boilers are used with a cascade flue PAR 1 on each boiler must be reset.
On natural gas PAR 1 = 4
On LPG PAR 1 = 12

Parameter 1 will be displayed. Change the value using the \leftarrow and \rightarrow ..
The standard display returns automatically after 60 seconds, or by pressing one of the control keys.

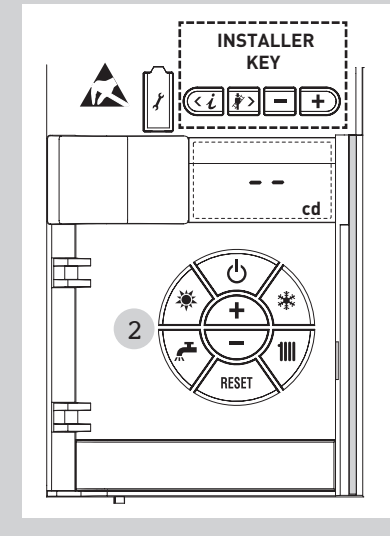

AVAILABLE AS OPTIONAL, THE FOLLOWING \varnothing 160 POLYPROPYLENE EXHAUST FUMES ACCESSORIES

Extension L. 500
code 8102522

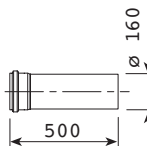

Extension L. 1000
code 8102523

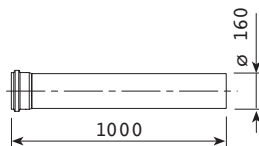

Extension 45° MF
code 8102520

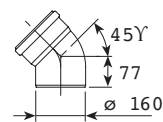

90° Bend MF
code 8102521

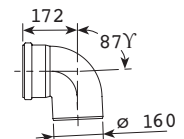

5 CASCADE CONNECTION

- 1 Connect the RS 485 boards as shown.

Connect the external temperature sensor (SE) to **MASTER** boiler and heating flow sensor (SMC) to **SLAVE 1**.

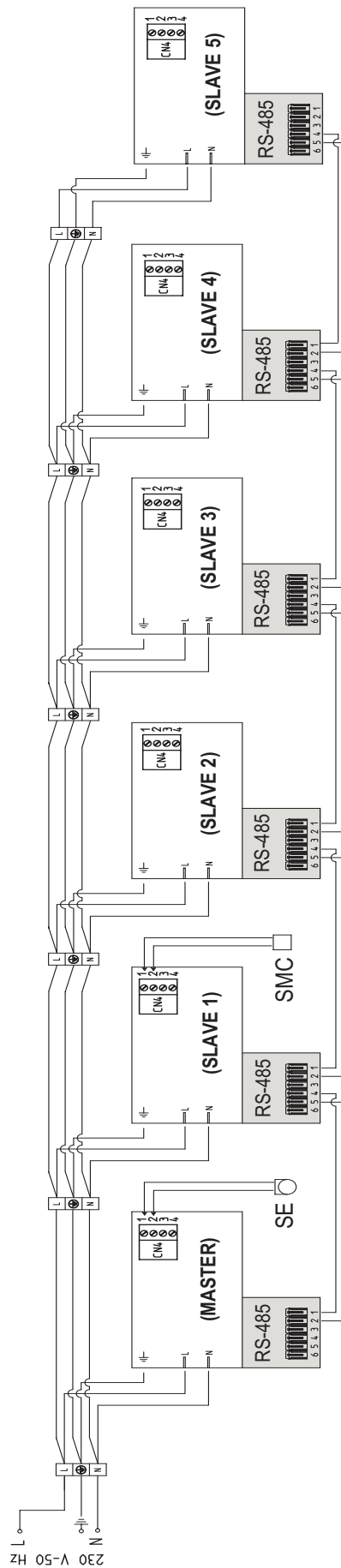

6 CASCADE MANAGEMENT

After connecting in cascade the boilers must be configured.
 One boiler must be assigned as the master and others as slaves.
 To do this PAR 15 on each boiler must be reset.

On each boiler press any key to wake up the display. Then press simultaneously the and the buttons for 5 seconds until the display is as shown.



Press the key until PAR 15 is shown in the bottom right hand corner.

Using the and keys reset the value accordingly.

On the MASTER set PAR 15 = 0

On the first SLAVE set PAR 15 =1

*Second SLAVE set PAR 15 =2 ,

To confirm the setting press

*CASCADE WITH MORE THAN TWO BOILERS

When more than two boilers are connected in cascade, it is essential that the OEM parameter on the “Master” boiler is reset to coincide with the number of boilers in the cascade.

This must be done after setting PAR 15 on the designated Master boiler to “0”

On the “Master” boiler press any key to wake up the display. Then press simultaneously the and the buttons for 5 seconds until the display is as shown.



Then press again, simultaneously, the and the buttons for 2 seconds until the display shows.

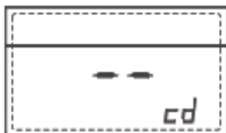

Next press, in the order shown .
 The display will be as shown.



Press the button, and the display will show



Use the and buttons to set the number of boilers in the cascade.

Then press to confirm the settings.

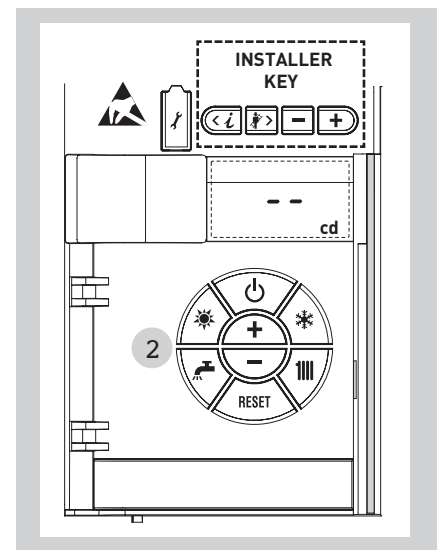

SERVICE & INTERIM BOILER WORK RECORD

It is recommended that your boiler and heating system are regularly serviced and maintained, in line with manufacturers' instructions, and that the appropriate service / interim work record is completed.

Service provider

When completing a service record (as below), please ensure you have carried out the service as described in the manufacturers' instructions. Always use the manufacturers' specified spare parts.

SERVICE/INTERIM WORK ON BOILER <small>delete as appropriate</small>					Date:	
Engineer name:		Company name:				
Telephone N°:		Gas Safe registration N°:				
Max rate	CO	ppm	CO ₂	%	CO/CO ₂	
Min rate	CO	ppm	CO ₂	%	CO/CO ₂	
Where possible, has a flue integrity check been undertaken in accordance with manufacturers' instructions, and readings are correct?*					yes	
Gas rate:	m ³ /h	OR	ft ³ /h			
Were parts fitted? <small>delete as appropriate</small>	Yes	No				
Parts fitted:						
System inhibitor concentration has been checked and appropriate action taken, in accordance with BS 7593 and boiler manufacturers' instructions. *					yes	n/a
Comments:						
Signature:						

*A System inhibitor efficacy test is required on every annual service in accordance with the manufacturers' instructions and BS 7593. It is only acceptable to not have undertaken this if the service engineers attendance visit was in between annual services to attend a non-water facing component.

SERVICE/INTERIM WORK ON BOILER <small>delete as appropriate</small>					Date:	
Engineer name:		Company name:				
Telephone N°:		Gas Safe registration N°:				
Max rate	CO	ppm	CO ₂	%	CO/CO ₂	
Min rate	CO	ppm	CO ₂	%	CO/CO ₂	
Where possible, has a flue integrity check been undertaken in accordance with manufacturers' instructions, and readings are correct?*					yes	
Gas rate:	m ³ /h	OR	ft ³ /h			
Were parts fitted? <small>delete as appropriate</small>	Yes	No				
Parts fitted:						
System inhibitor concentration has been checked and appropriate action taken, in accordance with BS 7593 and boiler manufacturers' instructions. *					yes	n/a
Comments:						
Signature:						

*A System inhibitor efficacy test is required on every annual service in accordance with the manufacturers' instructions and BS 7593. It is only acceptable to not have undertaken this if the service engineers attendance visit was in between annual services to attend a non-water facing component.

SERVICE/INTERIM WORK ON BOILER <small>delete as appropriate</small>					Date:	
Engineer name:		Company name:				
Telephone N°:		Gas Safe registration N°:				
Max rate	CO	ppm	CO ₂	%	CO/CO ₂	
Min rate	CO	ppm	CO ₂	%	CO/CO ₂	
Where possible, has a flue integrity check been undertaken in accordance with manufacturers' instructions, and readings are correct?*					yes	
Gas rate:	m ³ /h	OR	ft ³ /h			
Were parts fitted? <small>delete as appropriate</small>	Yes	No				
Parts fitted:						
System inhibitor concentration has been checked and appropriate action taken, in accordance with BS 7593 and boiler manufacturers' instructions. *					yes	n/a
Comments:						
Signature:						

*A System inhibitor efficacy test is required on every annual service in accordance with the manufacturers' instructions and BS 7593. It is only acceptable to not have undertaken this if the service engineers attendance visit was in between annual services to attend a non-water facing component.

SERVICE/INTERIM WORK ON BOILER <small>delete as appropriate</small>					Date:	
Engineer name:		Company name:				
Telephone N°:		Gas Safe registration N°:				
Max rate	CO	ppm	CO ₂	%	CO/CO ₂	
Min rate	CO	ppm	CO ₂	%	CO/CO ₂	
Where possible, has a flue integrity check been undertaken in accordance with manufacturers' instructions, and readings are correct?*					yes	
Gas rate:	m ³ /h	OR	ft ³ /h			
Were parts fitted? <small>delete as appropriate</small>	Yes	No				
Parts fitted:						
System inhibitor concentration has been checked and appropriate action taken, in accordance with BS 7593 and boiler manufacturers' instructions. *					yes	n/a
Comments:						
Signature:						

*A System inhibitor efficacy test is required on every annual service in accordance with the manufacturers' instructions and BS 7593. It is only acceptable to not have undertaken this if the service engineers attendance visit was in between annual services to attend a non-water facing component.

SERVICE/INTERIM WORK ON BOILER <small>delete as appropriate</small>					Date:	
Engineer name:		Company name:				
Telephone N°:		Gas Safe registration N°:				
Max rate	CO	ppm	CO ₂	%	CO/CO ₂	
Min rate	CO	ppm	CO ₂	%	CO/CO ₂	
Where possible, has a flue integrity check been undertaken in accordance with manufacturers' instructions, and readings are correct?*					yes	
Gas rate:	m ³ /h	OR	ft ³ /h			
Were parts fitted? <small>delete as appropriate</small>	Yes	No				
Parts fitted:						
System inhibitor concentration has been checked and appropriate action taken, in accordance with BS 7593 and boiler manufacturers' instructions. *					yes	n/a
Comments:						
Signature:						

*A System inhibitor efficacy test is required on every annual service in accordance with the manufacturers' instructions and BS 7593. It is only acceptable to not have undertaken this if the service engineers attendance visit was in between annual services to attend a non-water facing component.

SERVICE/INTERIM WORK ON BOILER <small>delete as appropriate</small>					Date:	
Engineer name:		Company name:				
Telephone N°:		Gas Safe registration N°:				
Max rate	CO	ppm	CO ₂	%	CO/CO ₂	
Min rate	CO	ppm	CO ₂	%	CO/CO ₂	
Where possible, has a flue integrity check been undertaken in accordance with manufacturers' instructions, and readings are correct?*					yes	
Gas rate:	m ³ /h	OR	ft ³ /h			
Were parts fitted? <small>delete as appropriate</small>	Yes	No				
Parts fitted:						
System inhibitor concentration has been checked and appropriate action taken, in accordance with BS 7593 and boiler manufacturers' instructions. *					yes	n/a
Comments:						
Signature:						

*A System inhibitor efficacy test is required on every annual service in accordance with the manufacturers' instructions and BS 7593. It is only acceptable to not have undertaken this if the service engineers attendance visit was in between annual services to attend a non-water facing component.

* All installations in England and Wales must be notified to Local Authority Building Control (LABC) either directly or through a Competent Persons Scheme. A Building Regulations Compliance Certificate will then be issued to the customer.

© Heating and Hotwater Industry Council (HHIC)



www.centralheating.co.uk

SERVICE & INTERIM BOILER WORK RECORD

It is recommended that your boiler and heating system are regularly serviced and maintained, in line with manufacturers' instructions, and that the appropriate service / interim work record is completed.

Service provider

When completing a service record (as below), please ensure you have carried out the service as described in the manufacturers' instructions. Always use the manufacturers specified spare parts.

SERVICE/INTERIM WORK ON BOILER <small>delete as appropriate</small>					Date:
Engineer name:		Company name:			
Telephone N°:		Gas Safe registration N°:			
Max rate	CO	ppm	CO ₂	%	CO/CO ₂
Min rate	CO	ppm	CO ₂	%	CO/CO ₂
Where possible, has a flue integrity check been undertaken in accordance with manufacturers' instructions, and readings are correct?*					yes
Gas rate:	m ³ /h	OR	ft ³ /h		
Were parts fitted? <small>delete as appropriate</small>					Yes No
Parts fitted:					
System inhibitor concentration has been checked and appropriate action taken, in accordance with BS 7593 and boiler manufacturers' instructions. *					yes n/a
Comments:					
Signature:					

*A System inhibitor efficacy test is required on every annual service in accordance with the manufacturers' instructions and BS 7593. It is only acceptable to not have undertaken this if the service engineers attendance visit was in between annual services to attend a non-water facing component.

SERVICE/INTERIM WORK ON BOILER <small>delete as appropriate</small>					Date:
Engineer name:		Company name:			
Telephone N°:		Gas Safe registration N°:			
Max rate	CO	ppm	CO ₂	%	CO/CO ₂
Min rate	CO	ppm	CO ₂	%	CO/CO ₂
Where possible, has a flue integrity check been undertaken in accordance with manufacturers' instructions, and readings are correct?*					yes
Gas rate:	m ³ /h	OR	ft ³ /h		
Were parts fitted? <small>delete as appropriate</small>					Yes No
Parts fitted:					
System inhibitor concentration has been checked and appropriate action taken, in accordance with BS 7593 and boiler manufacturers' instructions. *					yes n/a
Comments:					
Signature:					

*A System inhibitor efficacy test is required on every annual service in accordance with the manufacturers' instructions and BS 7593. It is only acceptable to not have undertaken this if the service engineers attendance visit was in between annual services to attend a non-water facing component.

SERVICE/INTERIM WORK ON BOILER <small>delete as appropriate</small>					Date:
Engineer name:		Company name:			
Telephone N°:		Gas Safe registration N°:			
Max rate	CO	ppm	CO ₂	%	CO/CO ₂
Min rate	CO	ppm	CO ₂	%	CO/CO ₂
Where possible, has a flue integrity check been undertaken in accordance with manufacturers' instructions, and readings are correct?*					yes
Gas rate:	m ³ /h	OR	ft ³ /h		
Were parts fitted? <small>delete as appropriate</small>					Yes No
Parts fitted:					
System inhibitor concentration has been checked and appropriate action taken, in accordance with BS 7593 and boiler manufacturers' instructions. *					yes n/a
Comments:					
Signature:					

*A System inhibitor efficacy test is required on every annual service in accordance with the manufacturers' instructions and BS 7593. It is only acceptable to not have undertaken this if the service engineers attendance visit was in between annual services to attend a non-water facing component.

SERVICE/INTERIM WORK ON BOILER <small>delete as appropriate</small>					Date:
Engineer name:		Company name:			
Telephone N°:		Gas Safe registration N°:			
Max rate	CO	ppm	CO ₂	%	CO/CO ₂
Min rate	CO	ppm	CO ₂	%	CO/CO ₂
Where possible, has a flue integrity check been undertaken in accordance with manufacturers' instructions, and readings are correct?*					yes
Gas rate:	m ³ /h	OR	ft ³ /h		
Were parts fitted? <small>delete as appropriate</small>					Yes No
Parts fitted:					
System inhibitor concentration has been checked and appropriate action taken, in accordance with BS 7593 and boiler manufacturers' instructions. *					yes n/a
Comments:					
Signature:					

*A System inhibitor efficacy test is required on every annual service in accordance with the manufacturers' instructions and BS 7593. It is only acceptable to not have undertaken this if the service engineers attendance visit was in between annual services to attend a non-water facing component.

SERVICE/INTERIM WORK ON BOILER <small>delete as appropriate</small>					Date:
Engineer name:		Company name:			
Telephone N°:		Gas Safe registration N°:			
Max rate	CO	ppm	CO ₂	%	CO/CO ₂
Min rate	CO	ppm	CO ₂	%	CO/CO ₂
Where possible, has a flue integrity check been undertaken in accordance with manufacturers' instructions, and readings are correct?*					yes
Gas rate:	m ³ /h	OR	ft ³ /h		
Were parts fitted? <small>delete as appropriate</small>					Yes No
Parts fitted:					
System inhibitor concentration has been checked and appropriate action taken, in accordance with BS 7593 and boiler manufacturers' instructions. *					yes n/a
Comments:					
Signature:					

*A System inhibitor efficacy test is required on every annual service in accordance with the manufacturers' instructions and BS 7593. It is only acceptable to not have undertaken this if the service engineers attendance visit was in between annual services to attend a non-water facing component.

SERVICE/INTERIM WORK ON BOILER <small>delete as appropriate</small>					Date:
Engineer name:		Company name:			
Telephone N°:		Gas Safe registration N°:			
Max rate	CO	ppm	CO ₂	%	CO/CO ₂
Min rate	CO	ppm	CO ₂	%	CO/CO ₂
Where possible, has a flue integrity check been undertaken in accordance with manufacturers' instructions, and readings are correct?*					yes
Gas rate:	m ³ /h	OR	ft ³ /h		
Were parts fitted? <small>delete as appropriate</small>					Yes No
Parts fitted:					
System inhibitor concentration has been checked and appropriate action taken, in accordance with BS 7593 and boiler manufacturers' instructions. *					yes n/a
Comments:					
Signature:					

*A System inhibitor efficacy test is required on every annual service in accordance with the manufacturers' instructions and BS 7593. It is only acceptable to not have undertaken this if the service engineers attendance visit was in between annual services to attend a non-water facing component.

* All installations in England and Wales must be notified to Local Authority Building Control (LABC) either directly or through a Competent Persons Scheme. A Building Regulations Compliance Certificate will then be issued to the customer.

© Heating and Hotwater Industry Council (HHIC)



www.centralheating.co.uk

INSTALLATION CHECKLIST

SINGLE BOILER INSTALLATION

PAR 14 (See section 2.6.6) When BMS input used, and input is 10v, the required flow temperature = °C Set value of PAR 14

BOILERS INSTALLED IN CASCADE

ALL BOILERS IN THE CASCADE

PAR 15 (see fig 4/b) The cascade address must be set in each boiler in the cascade, denoting the master and each slave (Master = 0)

	Boiler 1	Boiler 2	Boiler 3	Boiler 4	Boiler 5	Boiler 6
Set value of PAR 15						

PAR 1 (see section 2.2.2) When installed with a cascade flue, incorporating a clappet(non return) valve, PAR 1 must be set accordingly on each boiler in the cascade

	Boiler 1	Boiler 2	Boiler 3	Boiler 4	Boiler 5	Boiler 6
Set value of PAR 1						

MASTER BOILER

OEM A1 (see section 2.2.2) When the number of boilers in the cascade is greater than two, the OEM A1 on the MASTER boiler (boiler with PAR 15=0), must be set to the same value as the number of boilers in the cascade. This can only be done after PAR 15 has been set.

Number of boilers in cascade
 Set value of OEMA1 on boiler number

PAR 14 (See section 2.6.6) When BMS input used, and input is 10v, the required flow temperature = °C Set value of PAR 14 on the master boiler

Commissioning Checklist for Boilers in Cascade

This checklist is for guidance only, and is not a full installation safety check

Address _____ Engineer _____

	1	2	3	4	5	6	7	8
Satisfactory visual check of flue Y/N								
Flue within allowable length and correctly terminated Y/N								
Confirm Tightness of installation pipework downstream of Isolating valve using leak detection fluid Y/N								
Check tightness of all valves Y/N								
Carryout ignition test of boiler with gas isolated to ensure boiler fails safe Y/N								
Turn on gas supply to boiler and isolate main burner(disconnect gas valve) and ensure boiler goes to lockout Y/N								
Reset boiler lockout and retry, ensuring boiler again locks out Y/N								
Reconnect gas valve, reset boiler lockout, and ensure boiler lights and is stable Y/N								
Test safety devices Y/N								
Safety stat(TS) - Disconnect - the boiler locks out Y/N								

	Boiler 1		Boiler 2		Boiler 3		Boiler 4		Boiler 5		Boiler 6		Boiler 7		Boiler 8	
	Min	Max	Min	Max	Min	Max	Min	Max	Min	Max	Min	Max	Min	Max	Min	Max
Flue analysis																
Boiler Output																
CO ppm																
CO2 %																
Ratio																
Boiler size																
Serial Number																
Completed By																
Date																

7 APPENDIX (GUIDANCE HHIC - October 2018 Issue 1.0)

Manufacturers Instructions

Manufacturer's instructions must be followed for the correct connection of the condensate discharge pipe from the boiler as this may vary due to the design of the boiler. For example a visible air break and trap is not required if there is a trap with a minimum condensate seal of 75 mm incorporated into the boiler.

Internal Pipe Run In Unheated Spaces

Condensate discharge pipes that are routed in an unheated space such as a loft or garage should be insulated to prevent freezing.

Internal Condensate Pipe Discharge Termination

Internal condensate discharge pipework must be a minimum of 19mm ID (typically 22mm OD) plastic pipe or as per manufacturer's instructions and this should "fall" a minimum of 45mm per metre away from the boiler, taking the shortest practicable route to the termination point.

(45mm as per BS6798, 52mm per metre as per industry practice is specified in the following diagrams)

To minimise the risk of freezing during prolonged sub-zero conditions, an internal "gravity discharge point" such as an internal soil stack (preferred method), internal kitchen, utility room or bathroom waste pipe e.g. from a sink, basin, bath or shower should be adopted, where possible.

Note - A suitable permanent connection to the foul waste pipe should be used. Figures 1, 2(a), 2(b) show appropriate connection methods.

Figure 1 – Connection of condensate discharge pipe to internal soil and vent stack.

Note – Check manufacturer's instructions to see if an air break is required.

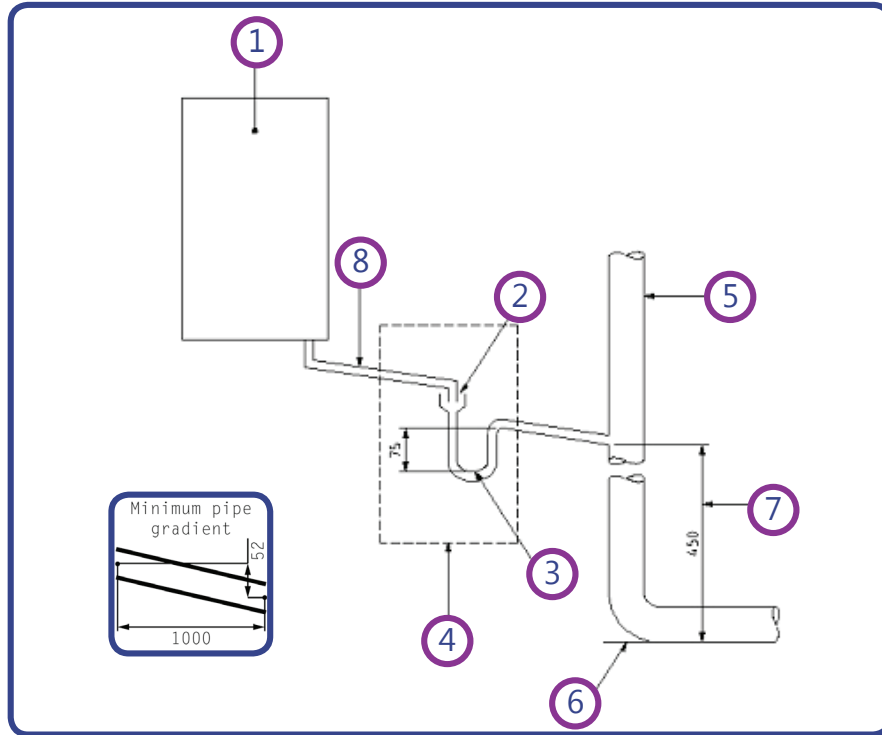

Key

- 1 Boiler
- 2 Visible air break
- 3 75 mm trap
- 4 Visible air break and trap not required if there is a trap with a minimum condensate seal of 75 mm incorporated into the boiler
- 5 Soil and vent stack
- 6 Invert
- 7 450 mm minimum up to three storeys
- 8 Minimum internal diameter 19 mm

Internal Condensate Pipe Discharge Termination

Figure 2(a) – Connection of a condensate discharge pipe downstream of a sink, basin, bath or shower waste trap.

Note – Check manufacturer's instructions to see if an air break is required.

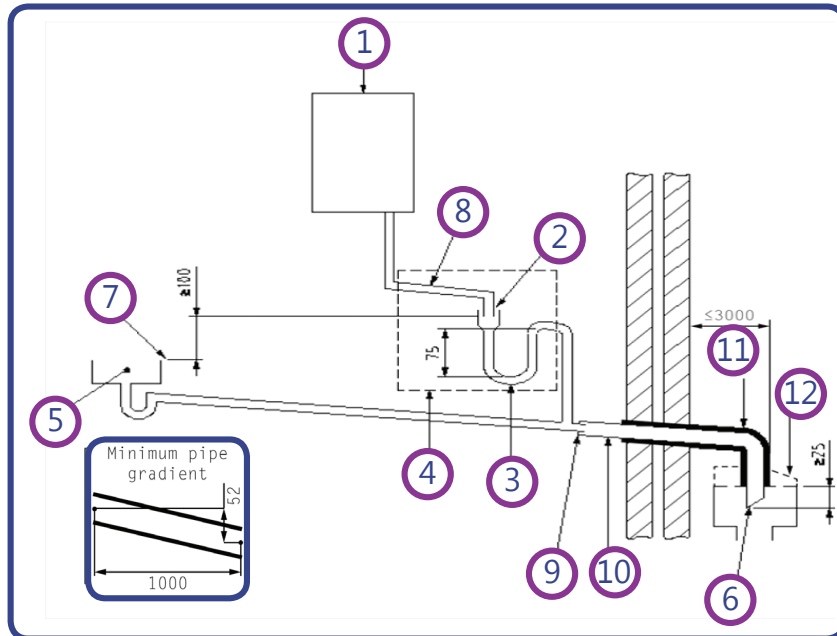

Key

- 1 Boiler
- 2 Visible air break
- 3 75 mm trap
- 4 Visible air break and trap not required if there is a trap with a minimum condensate seal of 75 mm incorporated into the boiler. In this case the 100 mm is measured to the trap in the boiler.
- 5 Sink, basin, bath or shower
- 6 Open end of condensate discharge pipe direct into gully 25 mm min below grating but above water level; end cut at 45°
Note – the maximum external condensate discharge length is 3 metres
- 7 Sink lip
- 8 Minimum internal diameter 19 mm
- 9 Pipe size transition
- 10 Minimum internal diameter 30 mm
- 11 Water/weather proof insulation
- 12 Drain cover/leaf guard

Internal Condensate Pipe Discharge Termination

Figure 2(b) – Connection of a condensate discharge pipe upstream of a sink, basin, bath or shower waste trap

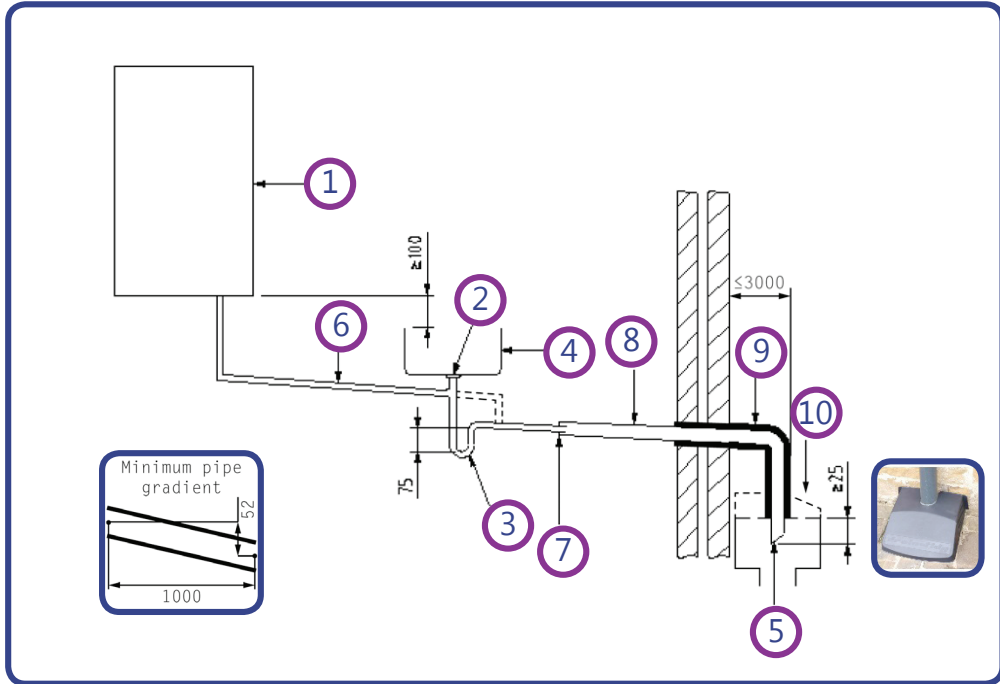

Key

- 1 Boiler
- 2 Visible air break at plug hole – alternative connection can be below sink trap
- 3 75 mm sink, basin, bath or shower waste trap
- 4 Sink, basin, bath or shower with integral overflow
- 5 Open end of condensate discharge pipe direct into gully 25 mm min below grating but above water level; end cut at 45 °
 Note – the maximum external condensate discharge length is 3 metres
- 6 Minimum internal diameter 19 mm
- 7 Pipe size transition
- 8 Minimum internal diameter 30 mm
- 9 Water/weather proof insulation
- 10 Fit drain cover/leaf guard



Internal Condensate Pipe Discharge Termination

The possibility of waste pipes freezing downstream of the connection point should be considered when determining a suitable connection point - e.g. a slightly longer pipe run to an internal soil stack may be preferable to a shorter run connecting into a kitchen waste pipe discharging directly through the wall to an external drain.

Note - Where "gravity discharge" to an internal termination is not physically possible (e.g. the discharge point is above the appliance location, or access is obstructed by a doorway), or where very long internal pipe runs would be required to reach a suitable discharge point, then a condensate pump should be used.

External waste pipes from kitchens, utility rooms or bathrooms such as sink, basin, and bath or shower waste outlets should be insulated with waterproof UV resistant, class 0 material, terminated below the grid but above the water line and a drain/leaf guard fitted. The waste pipe should be cut at 45 degrees where it terminates into the grid. (See insulation section for guidance on suitable materials).

Condensate Pumps

Use of a Condensate Pump to an Internal Termination

Condensate can be removed using a proprietary condensate pump, of a specification recommended by the boiler or pump manufacturer. In order to minimise the risk of freezing during prolonged sub-zero spells, one of the following methods internal to the property for terminating the boiler condensate pump to a foul water discharge point should be adopted such as an internal soil stack (preferred method), internal kitchen, utility room or bathroom waste pipe such as sink, basin, and bath or shower waste. Figure 3 shows a typical connection method.

Internal Condensate Pipe Discharge Termination

Figure 3 – Connection of a condensate pump - typical method (NB manufacturer’s detailed instructions should be followed).

Note – Any external pipe work should be insulated, pipe cut at 45 degrees and a drain/ leaf guard fitted.

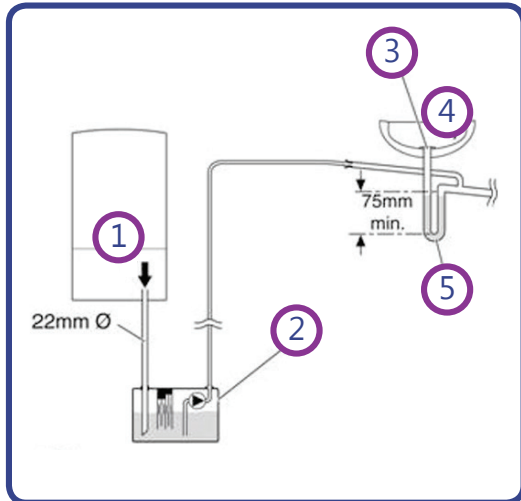

Key

- 1 Condensate discharge from boiler
- 2 Condensate pump
- 3 Visible air break at plug hole
- 4 Sink or basin with integrated overflow
- 5 75mm sink waste trap

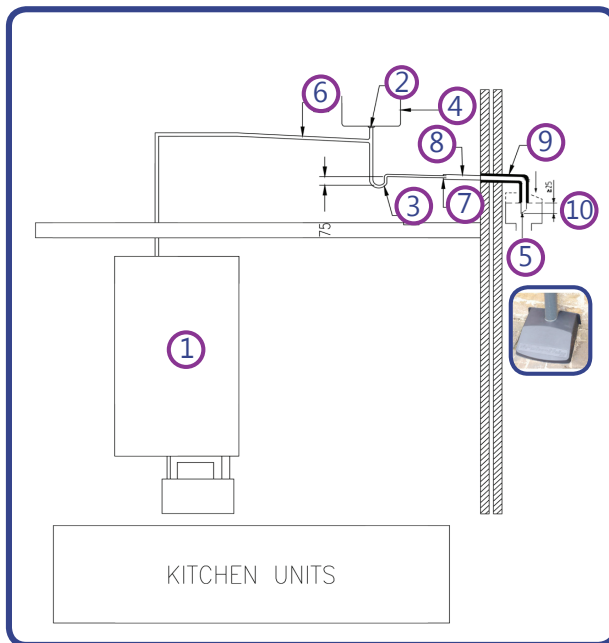

Key

- 1 Boiler
- 2 Visible air break at plug hole
- 3 75 mm sink, basin, bath or shower waste trap
- 4 Sink, basin, bath or shower with integral overflow
- 5 Open end of condensate discharge pipe direct into gully 25 mm min below grating but above water level; end cut at 45 ° Note – the maximum external condensate discharge length is 3 metres
- 6 Minimum internal diameter 19 mm
- 7 Pipe size transition
- 8 Minimum internal diameter 30 mm
- 9 Water/weather proof insulation
- 10 Fit drain cover/leaf guard



External Connections

External Connections

Only fit an external boiler condensate drain connection if an internal gravity or pumped connection is **impractical** to install.

The pipe work from the boiler should be of a minimum 19mm ID or as per manufacturer's instructions and the condensate discharge pipe shall be run in a standard drainpipe material, e.g. poly (vinyl chloride) (PVC), un-plasticized poly (vinyl chloride) (PVC-U), acrylonitrile butadiene-styrene (ABS), polypropylene (PP) or chlorinated poly (vinyl chloride) (PVC-C).

Note - Fixing centres for brackets should be a maximum of 300mm for flexible pipe and 500mm for solid pipe and manufacturer's recommendations should be followed.

The condensate pipe should be run internally as far as possible before going externally and the pipe diameter should be increased to a minimum of 30mm ID (typically 32mm OD) before it passes through the wall. The angle of the pipe should slope downwards by at least 3 degrees as it passes through the wall to assist in maintaining a good velocity as the condensate exits the building.

The external pipe run should be kept as short as possible to a maximum of 3 metres, taking the most direct and "most vertical" route to the discharge point, with no horizontal sections in which condensate might collect.

External Connections

Figure 4 – Connection of condensate discharge pipe to external soil and vent stack

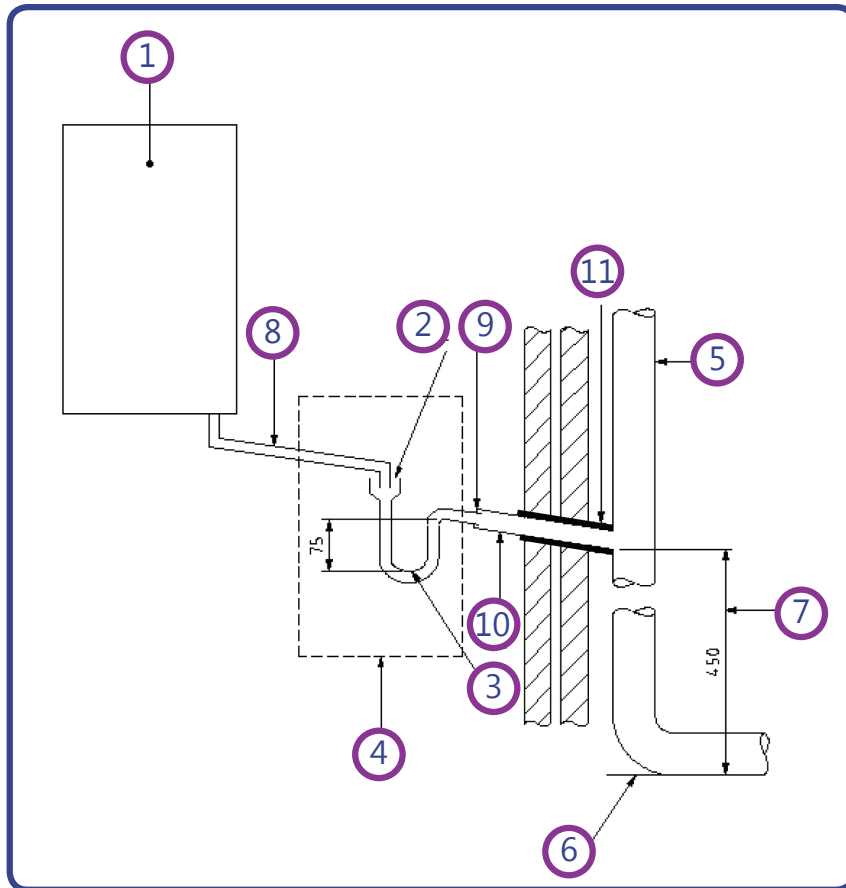

Key

- 1 Boiler
- 2 Visible air break
- 3 75 mm trap
- 4 Visible air break and trap not required if there is a trap with a minimum condensate seal of 75mm incorporated into the boiler.
- 5 Soil and vent stack
- 6 Invert
- 7 450mm minimum upto three storeys
- 8 Minimum internal diameter 19 mm
- 9 Pipe size transition point
- 10 Minimum internal diameter 30mm
- 11 Water/weather proof insulation



External Connections

Alternative Solutions

Cold weather protection methods approved or endorsed by boiler manufacturers and/or service organisations may be adopted if these are considered suitable by the parties involved. It is the responsibility of the manufacturer of these products to ensure they have completed the necessary testing or calculations to ensure the product offers suitable protection to prevent the condensate pipe from freezing. The product manufacturer should provide information as to what level of external temperature and for what time period the product can protect against sub-zero temperatures, i.e. -15°C for 48 hours. BS6798 refers to devices that pump the condensate produced by a condensing boiler to a fine misting nozzle in the boiler flue terminal so that the condensate is discharged with the hot flue gas. (BS6798 section 6.3.8 note 4). The boiler manufacturer's instructions will provide advice regarding fitting and siting of the flue terminal to ensure safe disposal of the condensate.

Additional Measures

At least one of the following measures should be fitted in addition to the measures detailed above for external condensate discharge pipes

- *Insulate external pipe with a minimum thickness of insulation to be 19mm "O" class PVC coated material.*
- *Fit trace heating – with insulation as recommended by manufacturer.*
- *Fit internal auxiliary(additional) high volume syphon unit*

Auxiliary Syphon – Fitted Internally

Auxiliary siphons fitted inside the premises assist with the siting of the boiler where an external condensate pipe **must** be fitted. The storage capacity of the auxiliary siphon increases the volume of condensate discharge reducing the risk of freezing. A further reduction in the potential for the pipe to freeze is achieved when combined with the external insulation requirements.

External Connections

Electric Trace Heating

Trace heating with an external thermostat can be fitted to the external condensate pipe to raise the temperature of the condensate pipe in freezing conditions. Trace heating takes the form of an electrical heating element run in physical contact along the length of the condensate pipe. The pipe is usually covered with thermal insulation to retain heat losses from the pipe. Heat generated by the element then maintains the temperature of the pipe. If such a system is used then the installation instructions of the trace heating manufacturer and any specific recommendations regarding pipe diameter, insulation, etc. should be followed. All other relevant guidance on condensate discharge pipe installation should also be followed.

Insulation Materials

Insulation used for external condensate pipes, sink or washing machine waste pipes should be of class 'O' grade with an outer coating that is weather proof, bird/animal proof, and UV resistant finish. A minimum of 19mm thick insulation is recommended for 32mm external pipes.

Use of Air Breaks In Condensate Discharge Pipes

Heating engineers should follow manufacturer's instructions on the use of air breaks in condensate discharge pipes. A visible air break is not required if the boiler condensate trap has a minimum condensate seal of 75mm incorporated into the boiler.

Connecting to a rain water downpipe/External Soil Stack

When an external soil stack or rain water downpipe is used as the termination (NB only permissible if this downpipe passes to a combined foul and rainwater drainage system) an external air break must be installed between the condensate discharge pipe and the downpipe to avoid reverse flow of rainwater/sewage into the boiler should the downpipe itself become flooded or frozen.

Figure 5 shows a suitable connection method. Pipe insulation should be fitted.

External Connections

Figure 5 – External termination to rainwater downpipe (NB only combined foul/rainwater drain)

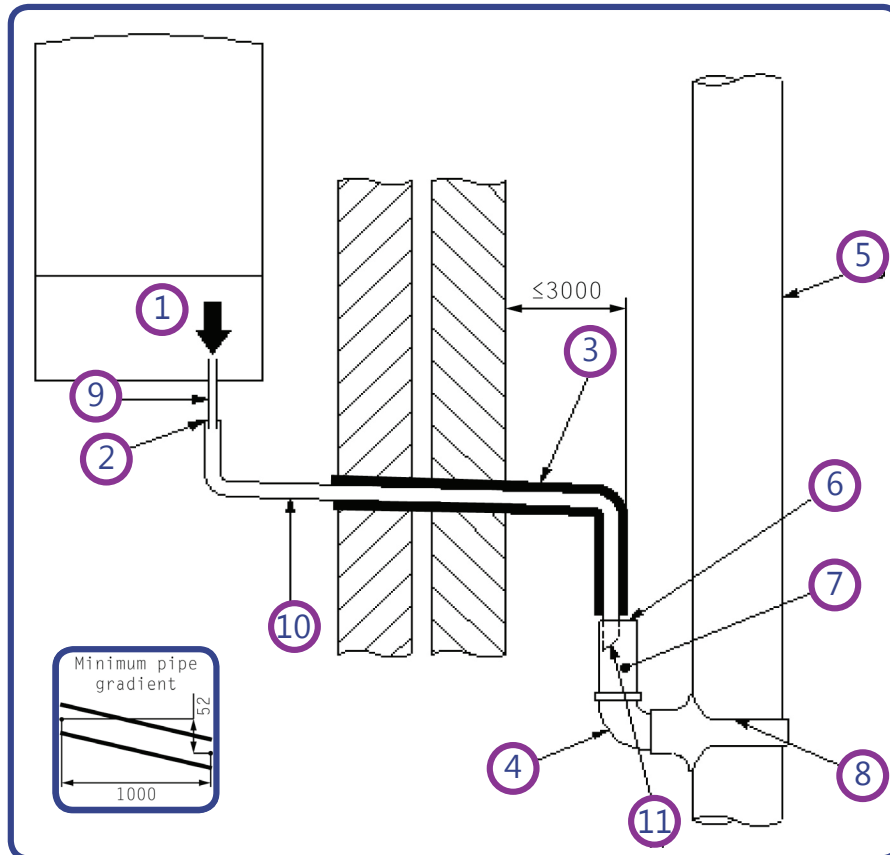

Key

- 1 Condensate discharge pipe from boiler
- 2 Pipe size transition point
- 3 Water/weather proof insulation
- 4 43mm 90° male/female bend
- 5 External rain water pipe into foul water
- 6 External air break
- 7 Air gap
- 8 68mm PVCu strap on fitting
- 9 Minimum internal diameter 19mm
- 10 Minimum internal diameter 30mm
- 11 End cut at 45°

External Connections

External Termination of the Condensate Pipe

Where the condensate discharge pipe is terminated over an open foul drain or gully, the pipe should terminate below the grating level, but above water level, in order to minimise “wind chill” at the open end. Pipe drainage and resistance to freezing will be improved if the termination end of the condensate pipe is cut at 45 degrees as opposed to a straight cut.

The use of a drain cover (such as those used to prevent blockage by leaves) **must** be fitted to offer further protection from wind chill. Figure 6 (following page) shows a suitable connection method. Where the condensate drain pipe terminates in a purpose-designed soakaway (see BS 6798:2014 or boiler installation manual for soakaway design requirements) any above-ground section of condensate discharge pipe should be run and insulated as described above. Figure 7 (following page) shows a suitable connection method.

Unheated Areas in Buildings

Internal condensate drainage pipes run in unheated areas such as lofts, basements and garages should be treated as external connections and insulated accordingly. Weather proof materials may not be necessary and should be assessed by the heating engineer.

Use of Air Breaks In Condensate Discharge Pipes

Installers should follow the manufacturer’s instructions on the use of air breaks in condensate discharge pipes. A visible air break and trap is not required if the boiler condensate trap has a minimum condensate seal of 75 mm incorporated into the boiler.

External Connections

Figure 6 – External drain, gully or rainwater hopper

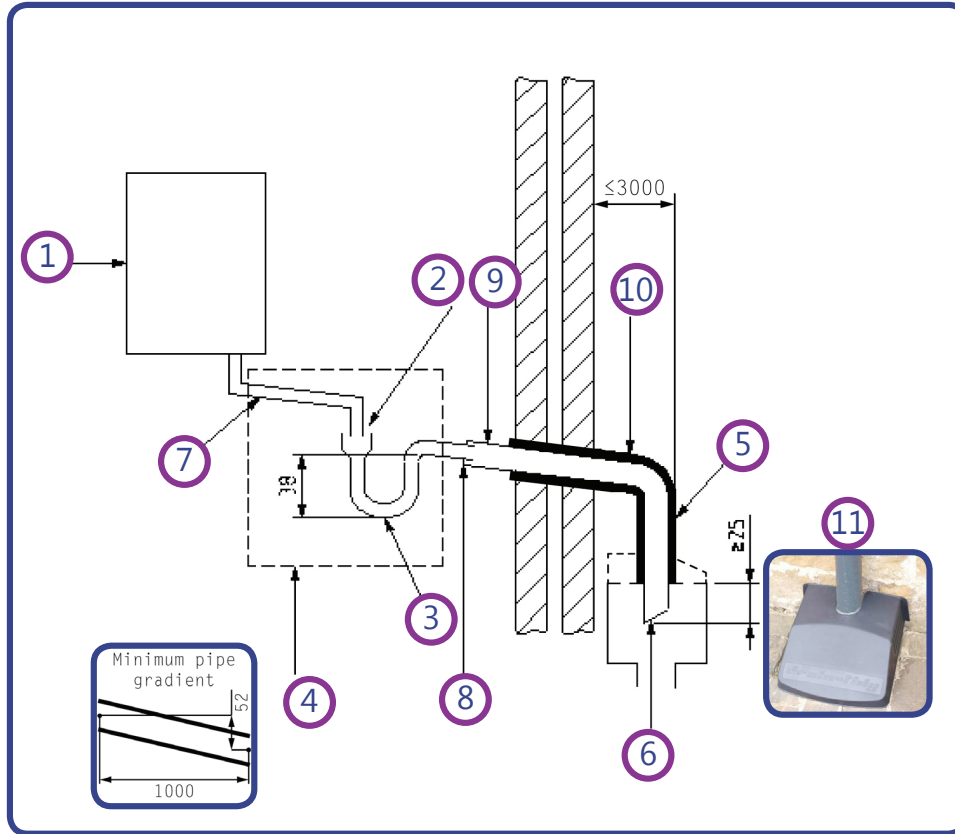

Key

- 1 Boiler
- 2 Visible air break
- 3 38mm minimum trap
- 4 Visible air break and trap not required if there is a trap with a minimum condensate seal of 38 mm incorporated into the boiler – refer to manufacturers instructions
- 5 External length of pipe 3 m maximum
- 6 Open end of condensate discharge pipe direct into gully 25 mm min below grating but above water level; end cut at 45°
- 7 Minimum internal diameter 19 mm
- 8 Pipe size transition point
- 9 Minimum internal diameter 30 mm
- 10 Water/weather proof insulation
- 11 Fit drain cover/leaf guard

External Connections

Figure 7 – Example of a purpose made soakaway

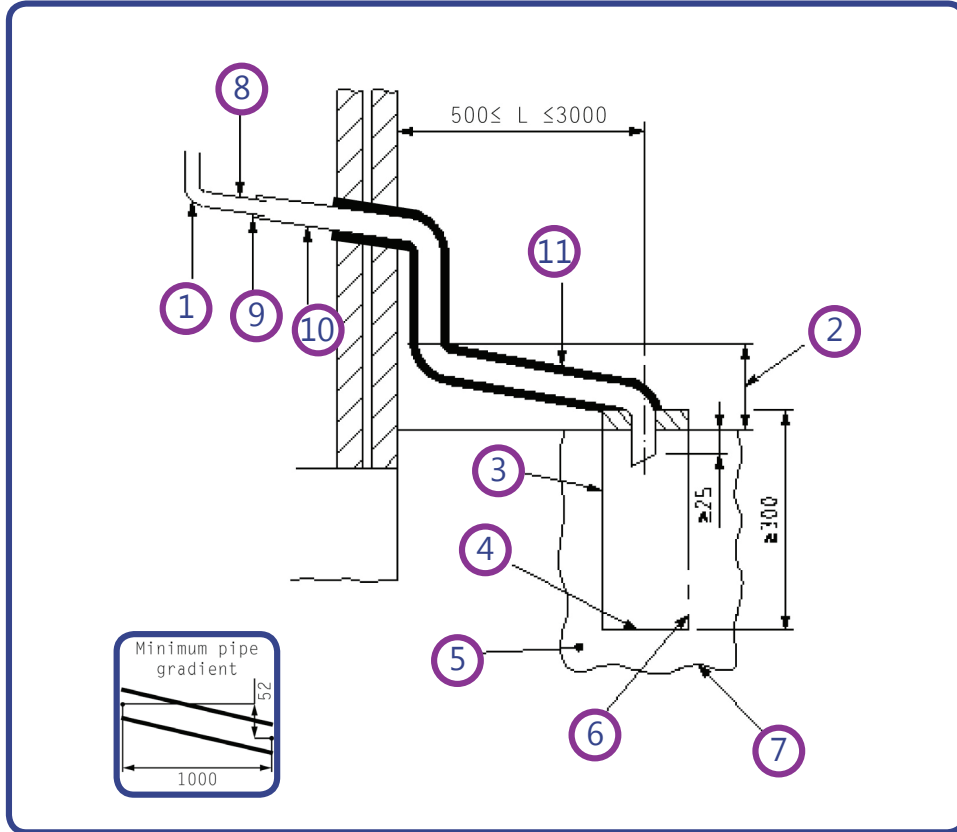

Key

- 1 Condensate discharge pipe from boiler
- 2 Ground (this section of the condensate discharge pipe may be run either above or below ground level); End cut at 45°
- 3 Diameter 100 mm minimum plastic tube
- 4 Bottom of tube sealed
- 5 Limestone chippings
- 6 Two rows of three 12 mm holes at 25 mm centres, 50 mm from bottom of tube and facing away from house
- 7 Hole depth 400 mm minimum by 300 mm diameter
- 8 Minimum internal diameter 19 mm
- 9 Pipe size transition point
- 10 Minimum internal diameter 30 mm
- 11 Water/weather proof insulation

8 APPENDIX 2 (VENTILATION GUIDENCE)

Ventilation Requirements for “Murelle Equipe 140 ErP” Cascade

BS6644:2005 requires the temperatures in the room or compartment not to exceed certain levels:

25°C up to 100 mm from floor level

32°C 1500 mm above floor level

40°C 100 mm from ceiling level

The following provided for guidance only, and assumes the ventilation air is taken directly from outside. The size of the vents may need to be increased in respect of other appliances installed in the same area, and seasonal use. Take care that the position of low level vents would not be subject to adverse weather conditions, i.e. flooding.

When installed as a class B appliance (opened flue, not room sealed).

Installed in a room

High level, within 15% of room height from the ceiling = 2 cm² per Kw net heat input (Nominal)

Low Level, low as possible within G20 - 1000 mm G31 - 250 mm = 4 cm² per Kw net heat input (Nominal)

Each model requirement for their net heat input is:

Murelle Equipe Cascade			
70 ErP	High	139 cm ²	Low 278 cm ²

Installed in a compartment or enclosure

High level, within 15% of room height from the ceiling = 5 cm² per Kw net heat input (Nominal)

Low Level, low as possible within G20 - 1000 mm G31 - 250 mm = 10 cm² per Kw net heat input (Nominal)

Each model requirement for their net heat input is:

Murelle Equipe Cascade			
70 ErP	High	348 cm ²	Low 696 cm ²

When installed as a class C appliance (room sealed)

Installed in a room

High level, within 15% of room height from the ceiling = 2 cm² per Kw net heat input (Nominal)

Low Level, low as possible within G20 - 1000 mm G31 - 250 mm = 2 cm² per Kw net heat input (Nominal)

Each model requirement for their net heat input is:

Murelle Equipe Cascade			
70 ErP	High	139 cm ²	Low 139 cm ²

Installed in a compartment or enclosure

High level, within 15% of room height from the ceiling = 5 cm² per Kw net heat input (Nominal)

Low Level, low as possible within G20 - 1000 mm G31 - 250 mm = 5 cm² per Kw net heat input (Nominal)

Each model requirement for their net heat input is:

Murelle Equipe Cascade			
70 ErP	High	348 cm ²	Low 348 cm ²



9 PRODUCT DETAILS

IT

ES

PT

EN

	
Murelle Equipe	70 ErP
Classe efficienza energetica stagionale riscaldamento Clase de eficiencia energética estacional en calefacción Classe de eficiência energética do aquecimento ambiente sazonal C.H. energy efficiency class	
Potenza termica (kW) Potencia térmica (kW) Potência calorífica (kW) Heat output (kW)	68
Consumo annuo di energia riscaldamento (GJ) Consumo anual de energía en calefacción (GJ) Consumo anual de energia para aquecimento (GJ) C.H. annual energy consumption (GJ)	110
Efficienza energetica stagionale riscaldamento (%) Eficiencia energética estacional en calefacción (%) Eficiência energética do aquecimento sazonal (%) C.H. seasonal energy efficiency (%)	93
Potenza sonora dB(A) Potencia sonora dB(A) Potência sonora dB(A) Sound power dB(A)	58
<p>Specifiche precauzioni da adottare al momento del montaggio, dell'installazione o della manutenzione dell'apparecchio sono contenute all'interno del manuale istruzioni della caldaia</p> <p>En el manual de instrucciones de la caldera se indican las precauciones específicas que se deben adoptar durante el montaje, la instalación o el mantenimiento del aparato</p> <p>Precauções específicas a tomar no momento da montagem, instalação ou manutenção do aparelho estão contidas no manual de instruções do aquecedor</p> <p>Specific precautionary measures to be adopted at the time of assembly, installation or maintenance of the equipment are contained in the boiler instruction manual</p> <p>Conforme all'allegato IV (punto 1) del regolamento delegato (UE) N° 811/2013 che integra la Direttiva 2010/30/UE</p> <p>Con arreglo al anexo IV (punto 1) del Reglamento Delegado (UE) N° 811/2013 que completa la Directiva 2010/30/UE</p> <p>Em conformidade com o anexo IV (ponto 1) do regulamento delegado (UE) N.º 811/2013 que complementa a Diretiva 2010/30/UE</p> <p>Conforming to Annex IV (item 1) of the Delegated Regulations (EU) No. 811/2013 which supplements Directive 2010/30/EU</p>	

10 ANNEX AA.1

Murelle Equipe 70 ErP (code 8113111)

IT
ES
PT
EN

Informazioni da fornire per le caldaie per il riscaldamento d'ambiente e le caldaie miste Información obligatoria para calderas de calefacción de espacios y calderas mixtas Informações a fornecer para aquecedores de ambiente com caldeira e aquecedores combinados com caldeira Information requirements for boiler space heaters, boiler combination heaters							
Modello / Modelos / Modelos / Model:		MURELLE EQUIPE 70 ErP					
Caldaia a condensazione / Caldera de condensación: Caldeira de condensação / Condensing boiler:		Yes					
Caldaia a bassa temperatura / Caldera de baja temperatura: Caldeira de baixa temperatura / Low-temperature boiler:		Yes					
Caldaia di tipo B11/ Caldera de tipo B11/ Caldeira B11 / B11 boiler:		No					
Apparecchio di cogenerazione per il riscaldamento d'ambiente: Equipo de cogeneración para calefacción de espacios: Aquecedor de ambiente com cogeração: Cogenerator space heater:		No	Munito di un apparecchio di riscaldamento supplementare: Equipado con un aparato de calefacción suplementario: Equipado com aquecedor complementar: Equipped with a supplementary heater:				No
Apparecchio di riscaldamento misto / Equipo de calefacción mixto: Aquecedor combinado / Combunation heater:		No					
Elemento / Elemento Elemento / item	Symbol	Value	Unit	Elemento / Elemento Elemento / item	Symbol	Value	Unit
Potenza termica nominale Potencia térmica nominal Potência calorífica nominal Nominal heat output for space heating	P _n	68	kW	Efficienza energetica stagionale del riscaldamento d'ambiente Eficiencia energética estacional de calefacción Eficiência energética do aquecimento ambiente sazonal Seasonal space heating energy efficiency	η _s	93	%
Per le caldaie per il riscaldamento d'ambiente e le caldaie miste: potenza termica utile Para calderas de calefacción de espacios y calderas mixtas: potencia térmica útil Aquecedores de ambiente com caldeira e aquecedores combinados equipados com caldeira: energia calorífica útil For boiler space heaters and boiler combination heaters: useful heat output				Per le caldaie per il riscaldamento d'ambiente e le caldaie miste: efficienza utile Para calderas de calefacción de espacios y calderas mixtas: eficiencia útil Aquecedores de ambiente com caldeira e aquecedores combinados equipados com caldeira: eficiência útil For boiler space heaters and boiler combination heaters: useful efficiency			
Alla potenza termica nominale e a un regime ad alta temperatura ^a A potencia calorífica nominal y régimen de alta temperatura ^a À potência calorífica nominal e em regime de alta temperatura ^a At nominal heat output and high-temperature regime ^a	P ₄	67,6	kW	Alla potenza termica nominale e a un regime ad alta temperatura (*) A potencia calorífica nominal y régimen de alta temperatura (*) À potência calorífica nominal e em regime de alta temperatura (*) At nominal heat output and high-temperature regime (*)	η ₄	87,5	%
Al 30% della potenza termica nominale e a un regime a bassa temperatura ^b A 30% de potencia calorífica nominal y régimen de baja temperatura ^b A 30% da potência calorífica nominal e em regime de baixa temperatura ^b At 30% of nominal heat output and low-temperature regime ^b	P ₁	20,3	kW	Al 30% della potenza termica nominale e a un regime a bassa temperatura (*) A 30% de potencia calorífica nominal y régimen de baja temperatura (*) A 30% da potência calorífica nominal e em regime de baixa temperatura (*) At 30% of nominal heat output and low-temperature regime (*)	η ₁	97,7	%
Consumo ausiliario di elettricità / Consumos eléctricos auxiliares Consumos eléctricos auxiliares / Auxiliary electricity consumption				Altri elementi / Otros elementos Outros elementos / Other items			
A pieno carico A plena carga Em plena carga At full load	e _{l_max}	0,128	kW	Dispersione termica in stand-by Dispersión térmica en stand-by Perdas de calor em modo de vigília Standby heat loss	P _{stby}	0,216	kW
A carico parziale A carga parcial Em carga parcial At part load	e _{l_min}	0,030	kW	Consumo energetico del bruciatore di accensione Consumo energético del quemador de encendido Consumo de energia do queimador de ignição Ignition burner power consumption	P _{ign}	0	kW
In modo standby / En modo de espera Em modo de vigília / In standby mode	PSB	0,009	kW	Emissioni di NOx / Emisiones de Nox Emissões de Nox / Emission of nitrogen oxides	NOx	29	mg/kWh
Per gli apparecchi di riscaldamento misto / Para los calefactores combinados / Aquecedores combinados / For combination heaters:							
Profilo di carico dichiarato Perfil de carga declarado Perfil de carga declarado / Declared load profile	--			Efficienza energetica di riscaldamento dell'acqua Eficiencia energética de caldeo de agua Eficiência energética do aquecimento de água Water heating energy efficiency	η _{wh}	--	%
Consumo quotidiano di energia Consumo diario de electricidad Consumo diário de eletricidade Daily electricity consumption	Q _{elec}	--	kWh	Consumo quotidiano di combustibile Consumo diario de combustível Consumo diário de combustível Daily fuel consumption	Q _{fuel}	--	kWh
Recapiti / Datos de contacto Elementos de contacto / Contact details		Fonderie Sime S.p.A. Via Garbo 27, 37045 Legnago (VR) ITALIA					
<p>a. Regime ad alta temperatura: temperatura di ritorno di 60°C all'entrata e 80°C di temperatura di fruizione all'uscita dell'apparecchio</p> <p>b. Bassa temperatura: temperatura di ritorno (all'entrata della caldaia) per le caldaie a condensazione 30°C, per le caldaie a bassa temperatura 37°C e per le altre caldaie 50°C</p> <p>a. Régimen de alta temperatura: temperatura de retorno de 60°C a la entrada y 80°C de temperatura de alimentación a la salida del aparato.</p> <p>b. Baja temperatura: temperatura de retorno (a la entrada de la caldera) de 30°C para las calderas de condensación, de 37°C para las calderas de baja temperatura y de 50°C para las demás calderas.</p> <p>a. Regime de alta temperatura: temperatura de retorno de 60°C à entrada do aquecedor e temperatura de alimentação de 80°C à saída do aquecedor.</p> <p>b. Baixa temperatura: temperatura de retorno de 30°C para as caldeiras de condensação, 37°C para as caldeiras de baixa temperatura e 50°C para os outros aquecedores (à entrada do aquecedor).</p> <p>a. High-temperature regime means 60°C return temperature at heater inlet and 80°C feed temperature at heater outlet.</p> <p>b. Low-temperature regime means for condensig boilers 30°C, for low-temperature boilers 37°C and for other heaters 50°C return temperature.</p> <p>(*) Dati di rendimento calcolati con potere calorifico superiore H_s / Datos de rendimiento calculado con el valor calorifico superior H_s Os valores do desempenho calculados com valor calorifico superior H_s / Performance data calculated with gross calorific value H_s</p>							



Sime Ltd

1a Blue Ridge Park
Thunderhead Ridge
Glasshoughton, Castleford, WF10 4UA

Phone: 0345 901 1114

Fax: 0345 901 1115

www.sime.co.uk

Email: enquiries@sime.co.uk