

# MURELLE HE 50 R ErP

## USER, INSTALLATION AND SERVICING INSTRUCTIONS



ENSURE THAT THESE INSTRUCTIONS ARE LEFT FOR THE USER AFTER COMPLETION OF THE BENCHMARK SECTION

PLEASE READ THE IMPORTANT NOTICE WITHIN THIS GUIDE REGARDING YOUR BOILER WARRANTY



199839



Authorised User No. 02285

ORIGINAL INSTRUCTIONS

## IMPORTANT NOTICE

For the first year all of our appliances are protected by our manufacturer's guarantee which covers both parts and labour.

As you would expect from Sime Ltd, it is our aim to provide our valued customers with the best in after sales and service.

To take advantage of any extended warranty offered, all you have to do is to adhere to these 3 simple conditions:

- The installation must be carried out to Manufacturers Standards by a Gas Safe Registered Engineer, and recorded in the installation manual.
- The appliance must be registered with both Sime Ltd and Gas Safe within 30 days of installation.
- The appliance must be serviced every 12 months, within 30 days of the anniversary of the installation date, by either Sime Ltd or a Gas Safe registered engineer- ensuring that the Benchmark service record in the installation manual is completed.

Failure to comply with the above will result in only the 12 month warranty being offered.

In the absence of any proof of purchase, the 12 month warranty period will commence from the date of manufacture of the boiler as shown on the appliance data plate.

## SAFE HANDLING

This boiler may require 2 or more operatives to move it into its installation site, remove it from its packaging and during movement into its installation location. Manoeuvring the boiler may include the use of a sack truck and involve lifting pushing and pulling.

Caution should be exercised during these operations.

Operatives should be knowledgeable in handling techniques when performing these tasks and the following precautions should be considered:

- Grip the boiler at the base
- Be physically capable
- Use personal protective equipment as appropriate e.g. gloves, safety footwear.

During all manoeuvres and handling actions, every attempt should be made to ensure the following unless unavoidable and/or the weight is light.

- Keep back straight
- Avoid twisting at the waist
- Always grip with the palm of the hand
- Keep load as close to the body as possible
- Always use assistance

### WARNING

Caution should be exercised when performing any work on this appliance.

Protective gloves and safety glasses are recommended.

- Avoid direct contact with sharp edges.
- Avoid contact with any hot surfaces.

### NOTICE

Please be aware that due to the wet testing of the appliance, there may be some residual water in the hydraulic circuit.

- Protect any surfaces, carpets or floorings.
- Use a suitable container to catch any water that escapes when removing the protective caps from the connections.

# Code Of Practice

For the installation, commissioning and servicing  
of domestic heating and hot water products

Benchmark places responsibilities on both manufacturers and installers.\* The purpose is to ensure that customers\*\* are provided with the correct equipment for their needs, that it is installed, commissioned and serviced in accordance with the manufacturer's instructions by competent persons and that it meets the requirements of the appropriate Building Regulations. Installers are required to carry out work in accordance with the following:

## Standards of Work

- Be competent and qualified to undertake the work required.
- Install, commission, service and use products in accordance with the manufacturer's instructions provided.
- Ensure that where there is responsibility for design work, the installation is correctly sized and fit for purpose.
- Meet the requirements of the appropriate Building Regulations. Where this involves notifiable work be a member of a Competent Persons Scheme or confirm that the customer has notified Local Authority Building Control (LABC), prior to work commencing.
- Complete all relevant sections of the Benchmark Checklist/Service Record when carrying out commissioning or servicing of a product or system.
- Ensure that the product or system is left in a safe condition and, whenever possible, in good working order.
- Highlight to the customer any remedial or improvement work identified during the course of commissioning or servicing work.
- Refer to the manufacturer's helpline where assistance is needed.
- Report product faults and concerns to the manufacturer in a timely manner.

## Customer Service

- Show the customer any identity card that is relevant to the work being carried out prior to commencement or on request.
- Give a full and clear explanation/demonstration of the product or system and its operation to the customer.
- Hand over the manufacturer's instructions, including the Benchmark Checklist, to the customer on completion of an installation.
- Obtain the customer's signature, on the Benchmark Checklist, to confirm satisfactory demonstration and receipt of manufacturer's instructions.
- Advise the customer that regular product servicing is needed, in line with manufacturers' recommendations, to ensure that safety and efficiency is maintained.
- Respond promptly to calls from a customer following completion of work, providing advice and assistance by phone and, if necessary, visiting the customer.
- Rectify any installation problems at no cost to the customer during the installer's guarantee period.



\*The use of the word "installer" is not limited to installation itself and covers those carrying out installation, commissioning and/or servicing of heating and hot water products, or the use of supporting products (such as water treatment or test equipment).

\*\*Customer includes householders, landlords and tenants.

## The Benchmark Scheme

Sime Ltd is a licensed member of the Benchmark Scheme which aims to improve the standards of installation and commissioning of domestic heating and hot water systems in the UK and to encourage regular servicing to optimise safety, efficiency and performance.

Benchmark is managed and promoted by the Heating and Hotwater Industry Council.

For more information visit [www.centralheating.co.uk](http://www.centralheating.co.uk).

Please ensure that the installer has fully completed the Benchmark Checklist in the use and maintenance section of the installation instructions supplied with the product and that you have signed it to say that you have received a full and clear explanation of its operation.

The installer is legally required to complete a commissioning checklist as a means of complying with the appropriate Building Regulations (England and Wales).

All installations must be notified to Local Area Building Control either directly or through a Competent Persons Scheme.

A Building Regulations Compliance Certificate will then be issued to the customer who should, on receipt, write the Notification Number on the Benchmark Checklist.

This product should be serviced regularly to optimise its safety, efficiency and performance.

The service engineer should complete the relevant Service Record on the Benchmark Checklist after each service. The Benchmark Checklist may be required in the event of any warranty work and as supporting documentation relating to home improvements in the optional documents section of the Home Information Pack.

### IMPORTANT INFORMATION

**IT IS A STATUTORY REQUIREMENT THAT ALL GAS APPLIANCES ARE INSTALLED BY COMPETENT PERSONS, IN ACCORDANCE WITH THE GAS SAFETY (INSTALLATION AND USE) REGULATIONS (CURRENT EDITION).**

The manufacturer's instructions must not be taken as overriding any statutory requirements, and failure to comply with these regulations may lead to prosecution.

No modifications to the appliance should be made unless they are fully approved by the manufacturer.

**GAS LEAKS: DO NOT OPERATE ANY ELECTRICAL SWITCH, OR USE A NAKED FLAME. TURN OFF THE GAS SUPPLY AND VENTILATE THE AREA BY OPENING DOORS AND WINDOWS contact the gas emergency service on 0800111999.**

Murelle HE 50 R ErP: Gas Council number 41-283-60

### CONFORMITY

Our Company declares that MURELLE HE 50 R ErP boilers comply with the essential requirements of the following directives:

- Boiler Efficiency Directive 92/42/EEC
- Gas Regulation 2016/426/EC
- Electromagnetic Compatibility Directive 2014/30/UE
- Low Voltage Directive 2014/35/UE
- Ecodesign Directive 2009/125/EC
- Regulation (EU) N. 813/2013 - 811/2013
- Energy Labelling 2010/30/CE





## CONTENTS

1	DESCRIPTION OF THE BOILER.....	page 6
2	INSTALLATION.....	page 9
3	CHARACTERISTICS.....	page 22
4	COMMISSIONING, USE AND MAINTENANCE, INCLUDING BENCHMARK.....	page 30
5	FAULT FINDING.....	page 42
6	REPLACEMENT OF PARTS.....	page 43
7	EXPLODED VIEWS.....	page 44
8	APPENDIX 1.....	page 48
	USER INSTRUCTIONS.....	pag. 62
	PRODUCT DETAILS.....	pag. 64
	ANNEX AA.1.....	pag. 65

## VERY IMPORTANT!

PLEASE MAKE SURE YOUR COMMISSIONING CHECKLIST AND THE SERVICE INTERVAL RECORDS  
ENCLOSED FILLED IN CORRECTLY.

ALL GAS SAFE REGISTERED INSTALLERS CARRY A GAS SAFE ID CARD.  
BOTH SHOULD BE RECORDED IN YOUR COMMISSIONING CHECKLIST AND A SERVICE INTERVAL RECORDS.  
YOU CAN CHECK YOUR INSTALLER IS GAS SAFE REGISTERED BY CALLING  
ON 0800 408 5500 OR ALTERNATIVELY [WWW.GASSAFEREGISTER.CO.UK](http://WWW.GASSAFEREGISTER.CO.UK)

Please refer to commissioning instructions for filling in the checklist at the back of this installation guide.

Note: All Gas Safe registered installers carry a ID Card.

You can check your installer is Gas Safe Registered by calling 0800 408 5577

## IMPORTANT

When carrying out commissioning of the boiler, you are highly recommended to perform the following checks:

- Make sure that there are no liquids or inflammable materials in the immediate vicinity of the boiler.
- Make sure that the electrical connections have been made correctly and that the earth wire is connected to a good earthing system.
- Open the gas valve and check the soundness of the connections, including that of the burner.
- Make sure that the boiler is set for operation for the type of gas supplied.
- Check that the flue pipe for the outlet of the products of the combustion is unobstructed and has been properly installed.
- Make sure that any shutoff valves are open.
- Make sure that the system is charged with water and is thoroughly vented.
- Check that the circulating pump is not jammed.
- Purge the system, bleeding off the air present in the gas pipe by operating the pressure relief valve on the gas valve inlet.
- Complete the checklist included in this manual.

# 1 DESCRIPTION OF THE BOILER

## 1.1 INTRODUCTION

**MURELLE HE 50 R ErP** are premixed gas condensing heating modules for heating

only with wide range of power modulation (from 20% to 100% of power) designed for single installation and in modular systems with several generators con-

nected in sequence/cascade and independent from each other. For optimum installation and operation, always follow the instructions provided in this manual.

## 1.2 DIMENSIONS (fig. 1)

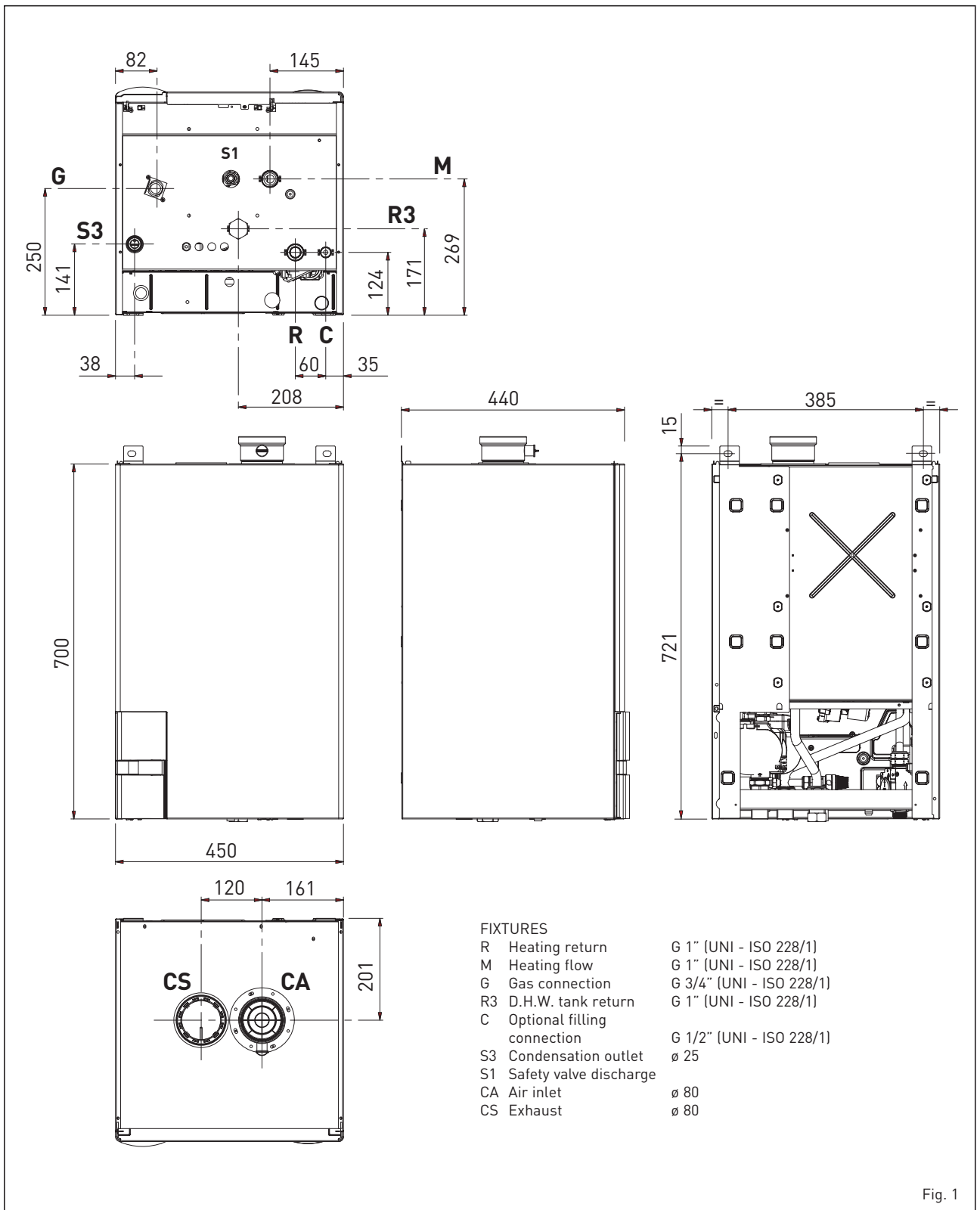

Fig. 1

### 1.3 TECHNICAL FEATURES

<b>MURELLE HE 50 R ErP</b>		
<b>Heat output</b>		
Nominal (80-60°C) (Pn max)	kW	46.8
Nominal (50-30°C) (Pn max)	kW	51.2
Reduced (80-60°C) (Pn min)	kW	9.3
Reduced (50-30°C) (Pn min)	kW	10.5
<b>Heat input (*)</b>		
Nominal (Qn max - Qnw max)	kW	48.0
Reduced (Qn min - Qnw min)	kW	9.6
<b>Min/max useful yield (80-60°C)</b>	%	96.9 / 97.5
<b>Min/max useful yield (50-30°C)</b>	%	109.0 / 106.7
<b>Useful yield at 30% of the load (40-30°C)</b>	%	108.5
<b>Losses after shutdown to 50°C (EN 15502)</b>	W	76
<b>Supply voltage</b>	V-Hz	230-50
<b>Adsorbed power consumption (Qn max - Qn min)</b>	W	141 - 90
<b>Electrical protection grade</b>	IP	X4D
<b>Energy efficiency</b>		
Seasonal energy efficiency class of the heating system		A
Seasonal energy efficiency of the heating system	%	93
Sound power of the heating system	dB (A)	53
<b>C.H. setting range</b>	°C	20/80
<b>Water content boiler</b>	l	2.3
<b>Maximum water head (PMS)</b>	bar (kPa)	3.5 (343)
<b>Maximum temperature (T max)</b>	°C	85
<b>Capacity of the heating expansion vessel</b>	l	--
<b>Pressure of the heating expansion vessel</b>	bar (kPa)	--
<b>Exhaust fumes temperature at max flow rate (80-60°C)</b>	°C	85
<b>Exhaust fumes temperature at min. flow rate (80-60°C)</b>	°C	70
<b>Exhaust fumes temperature at max flow rate (50-30°C)</b>	°C	52
<b>Exhaust fumes temperature at min. flow rate (50-30°C)</b>	°C	45
<b>Smokes flow min/max</b>	g/s	4.2 / 21.9
<b>CO<sub>2</sub> at max/min flow rate (G20)</b>	%	9.5 / 9.2
<b>CO<sub>2</sub> at max/min flow rate (G31)</b>	%	10.0 / 10.3
<b>NO<sub>x</sub> measured (EN 15502-1:2015)</b>	mg/kWh	20
<b>PIN number</b>		1312CM5613
<b>Category</b>		II2H3P
<b>Type</b>		B23-B53-B23P-B53P-C13-C33-C43-C53-C83
<b>NO<sub>x</sub> emission class (EN 15502-1:2015)</b>		6 (< 56 mg/kWh)
<b>Weight when empty</b>	kg	38
<b>Main burner nozzle</b>		
Quantity nozzles	n°	1
G20 nozzle diameter	ø mm	7.5
G31 nozzle diameter	ø mm	5.5
<b>Consumption at maximum/minimum flow rate</b>		
Maximum (G20)	m <sup>3</sup> /h	5.15
Minimum (G20)	m <sup>3</sup> /h	1.01
Maximum (G31)	kg/h	3.73
Minimum (G31)	kg/h	0.75
<b>Gas supply pressure</b>		
(G20)	mbar (kPa)	20 (1.96)
(G31)	mbar (kPa)	37 (3.63)

(\*) Heat input of the heating system measured using lower heating value (LHV)

### 1.4 FUNCTIONAL DIAGRAM (fig. 2)

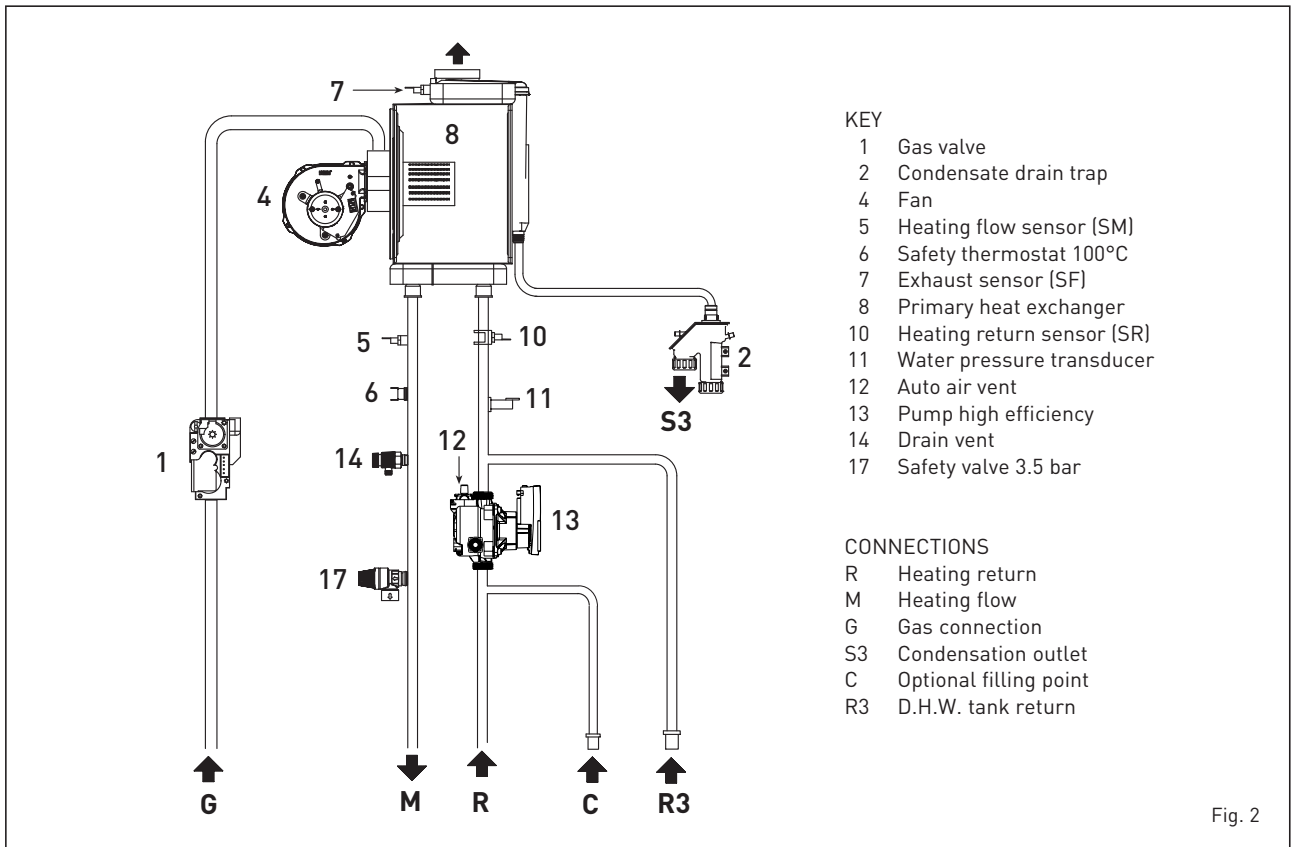

### 1.5 MAIN COMPONENTS (fig. 3)

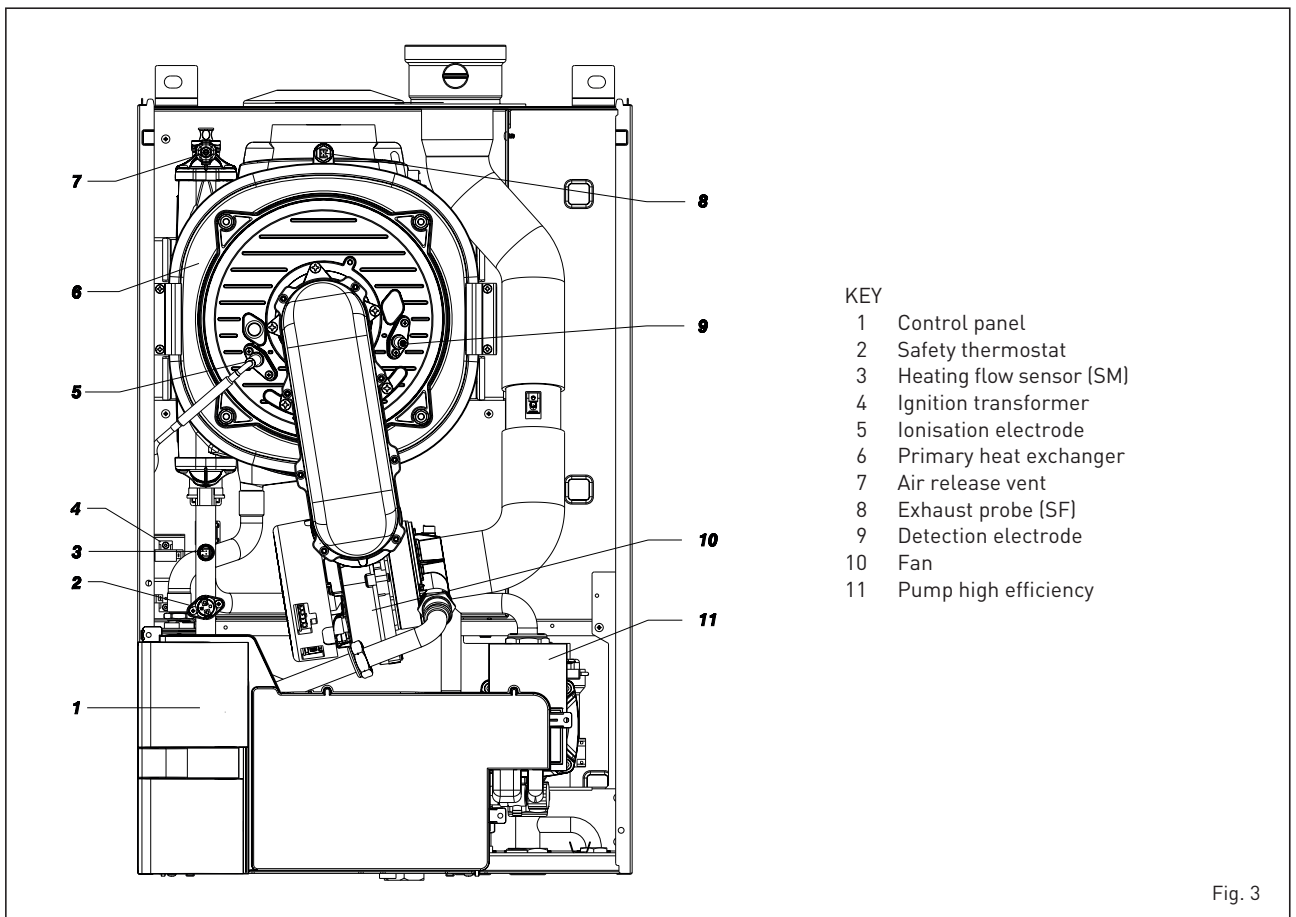

1.6 TECHNICAL DATA PLATE (fig. 3/a)

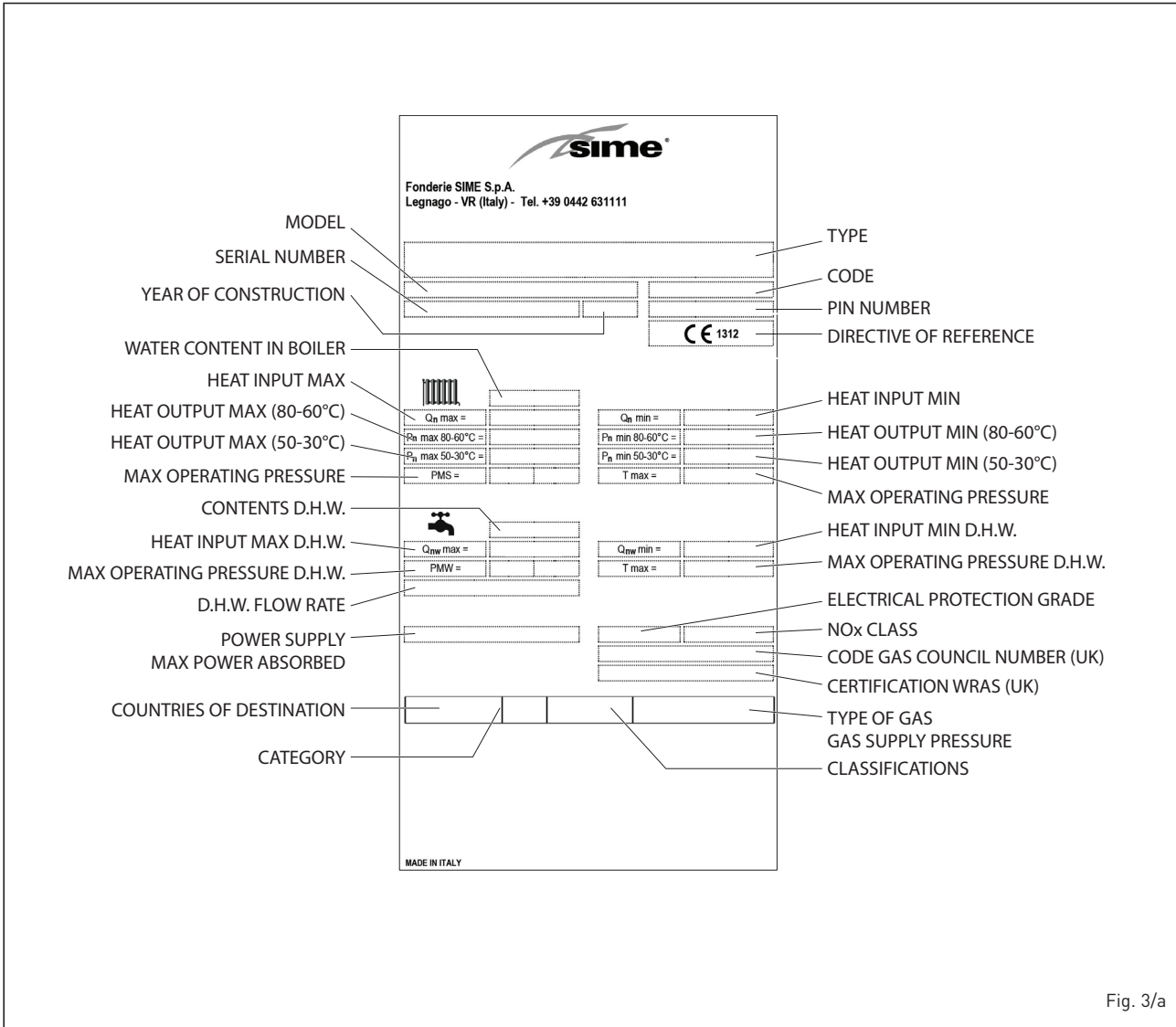

Fig. 3/a

## 2 INSTALLATION

The boiler must be installed in a fixed location, by qualified engineers in compliance with all instructions contained in this manual. Furthermore, the installation must be in accordance with current standards and regulations.

**CAUTION: Before assembling the appliance, the installer MUST make sure that the wall supports the weight.**

### 2.1 VENTILATION

MURELLE HE 50 R ErP can be installed

in boiler rooms whose size and requirements meet current regulations.

#### VENTILATION

The following is provided for your guidance only, and assumes the ventilation air is taken directly from outside. The sizes of the vents may need to be increased in respect of other appliances installed in the same area, and seasonal use. Take care that the position of low level vents would not be subject to adverse weather

conditions, ie flooding.

#### Ventilation requirements for Murelle HE 50 R ErP boilers and cascade systems.

BS6644 has a requirement that the temperatures in a room or compartment do not exceed certain levels:

- 25°C at floor level (0-100mm)
- 32°C at mid level (1.5M above the floor level)
- 40° C at ceiling level (0-100mm from ceiling)

**When installed as a class B appliance (open flued, not roomed sealed).**

#### Single installation with kit optional code 8101586

- M Heating flow R 2" (UNI-ISO 7/1)
- R Heating return R 2" (UNI-ISO 7/1)
- M2 D.H.W. tank flow G 1" (UNI-ISO 228/1)
- R3 D.H.W. tank return G 1" (UNI-ISO 228/1)

#### WARNING:

- The use of a hydraulic separator is mandatory.
- When replacing boilers in existing installations, it is advisable to install a heat exchanger to separate the boiler circuit from the secondary circuits. See the pressure curve for the boiler supply shown in figure 14.

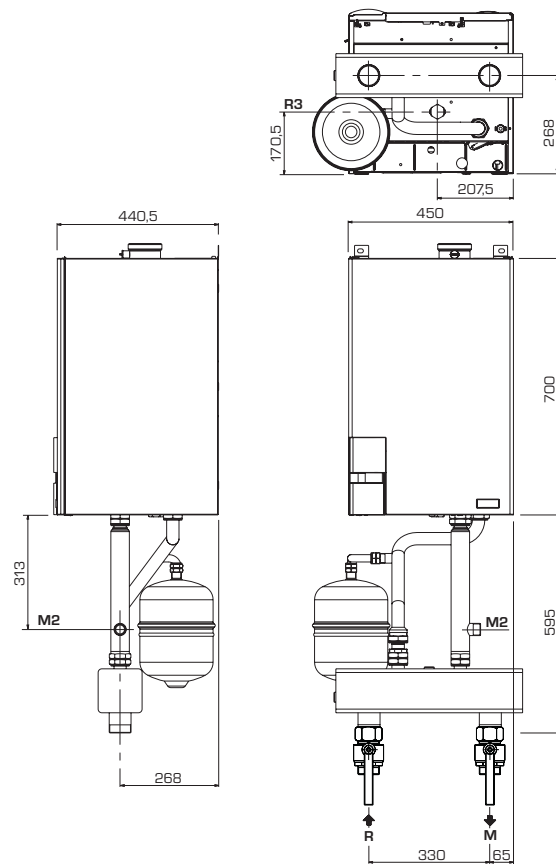

#### Installation in sequence/cascade

- R Heating return
- M Heating flow
- G Gas connection
- S3 Condensation outlet

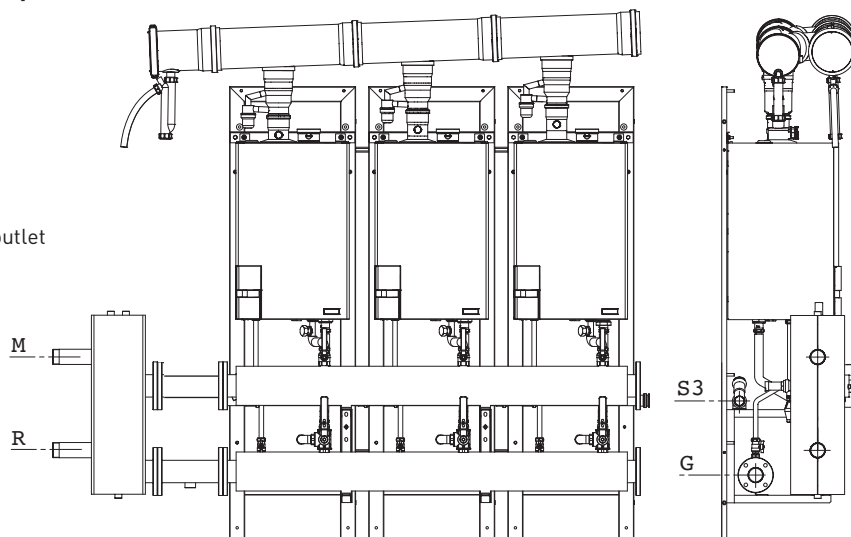

Fig. 4

Installed in a room

High level (within 15% of the room height from ceiling) - 2cm<sup>2</sup>/KW of net heat input

Low level (low as possible within 1 metre from floor natural gas, 250mm LPG)- 4cm<sup>2</sup>/KW of net heat input

A single Murelle HE 50 R (48KW net input) boiler would require 96cm<sup>2</sup> at high level and 192cm<sup>2</sup> at low level.

Installed in a compartment or enclosure  
High level (within 15% of the room height from ceiling) - 5cm<sup>2</sup>/KW of net heat input

Low level (low as possible within 1 metre from floor natural gas, 250mm LPG) - 10cm<sup>2</sup>/KW of net heat input.

A single Murelle HE 50 R (48KW net input) boiler would require 240cm<sup>2</sup> at high level and 480cm<sup>2</sup> at low level.

**When installed as a class C appliance(room sealed)**

Installed in a room

High level (within 15% of the room height from ceiling) - 2cm<sup>2</sup>/KW of net heat input

Low level (low as possible within 1 metre from floor natural gas, 250mm LPG)- 2cm<sup>2</sup>/KW of net heat input

A single Murelle HE 50 R (48KW net input) boiler would require 96cm<sup>2</sup> at high level and 96cm<sup>2</sup> at low level.

Installed in a compartment or enclosure  
High level (within 15% of the room height from ceiling) - 5cm<sup>2</sup>/KW of net heat input

Low level (low as possible within 1 metre from floor natural gas, 250mm LPG)- 5cm<sup>2</sup>/KW of net heat input.

A single Murelle HE50 R(48KW net input) boiler would require 240cm<sup>2</sup> at high level and 240cm<sup>2</sup> at low level.

**2.2 INSTALLATION**

**2.2.1 Single boiler (fig. 4)**

For single boiler installations a kit is available upon request: cod. 8101585.

**2.2.2 Sequence/cascade boilers (fig. 4 - fig. 4/a)**

For sequence/cascade installations where the boilers are connected to a cascade (common)flue system, PAR 1 of each boiler in the cascade must be reset as follows:

- **PAR 1 = 6** (for G20 NATURAL GAS boilers)
- **PAR 1 = 14** (for G31 PROPANE boilers)

Refer to section 3.3 to access the INSTALLER PARAMETERS section.

The boiler supplied with **RS-485** that board that allows management of up to 8 boilers in cascade and communication

in MODBUS.

The board is placed on the back of the control panel.

Access the board and chose the desired operating mode (CASCADE or MODBUS) by selecting the DIP SWITCH of the board as indicated in figure 4/a.

**CASCADE mode (fig. 4/b)**

Electrically connect all the boilers that form the modular cascade thermal system and set installer parameters PAR 15 on every single boiler as indicated in fig. 4/b.

**CASCADE WITH MORE THAN TWO BOILERS**

When more than two boilers are connected in cascade, it is essential that the OEM parameter on the "Master" boiler is reset to coincide with the number of boilers in the cascade.

This must be done after setting PAR 15 on the designated Master boiler to "0"

On the "Master" boiler press any key to wake up the display.

Then press simultaneously the and the buttons for 5 seconds until the display is as shown.

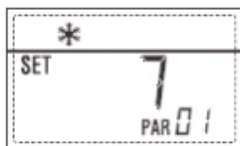

Then press again, simultaneously, the and the buttons for 2 seconds until the display shows.



Next press, in the order shown

The display will be as shown.



Press the button, and the display will show.



Use the and buttons to set the number of boilers in the cascade.

Then press to confirm the settings.

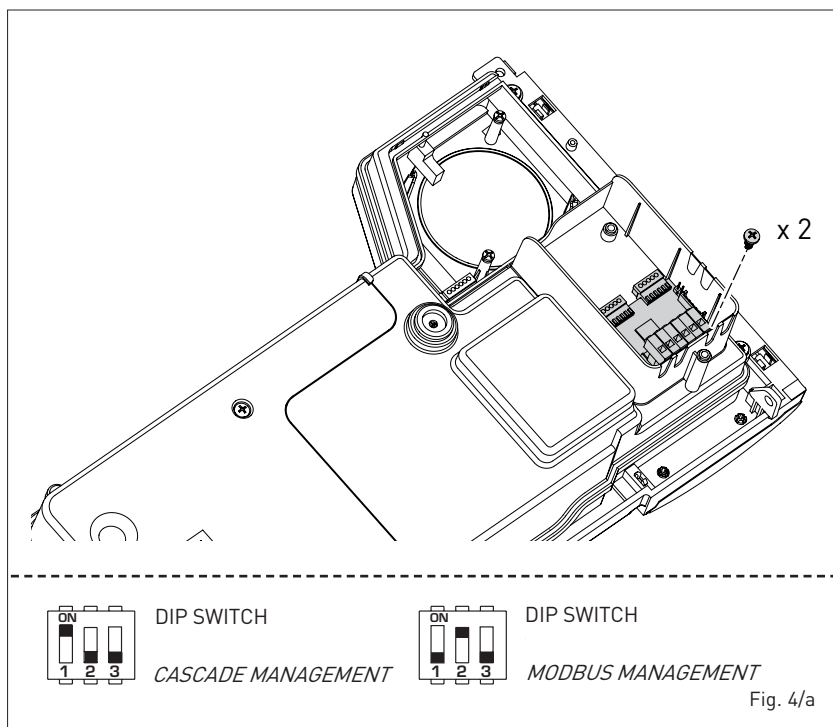

DIP SWITCH  
CASCADE MANAGEMENT



DIP SWITCH  
MODBUS MANAGEMENT

Fig. 4/a



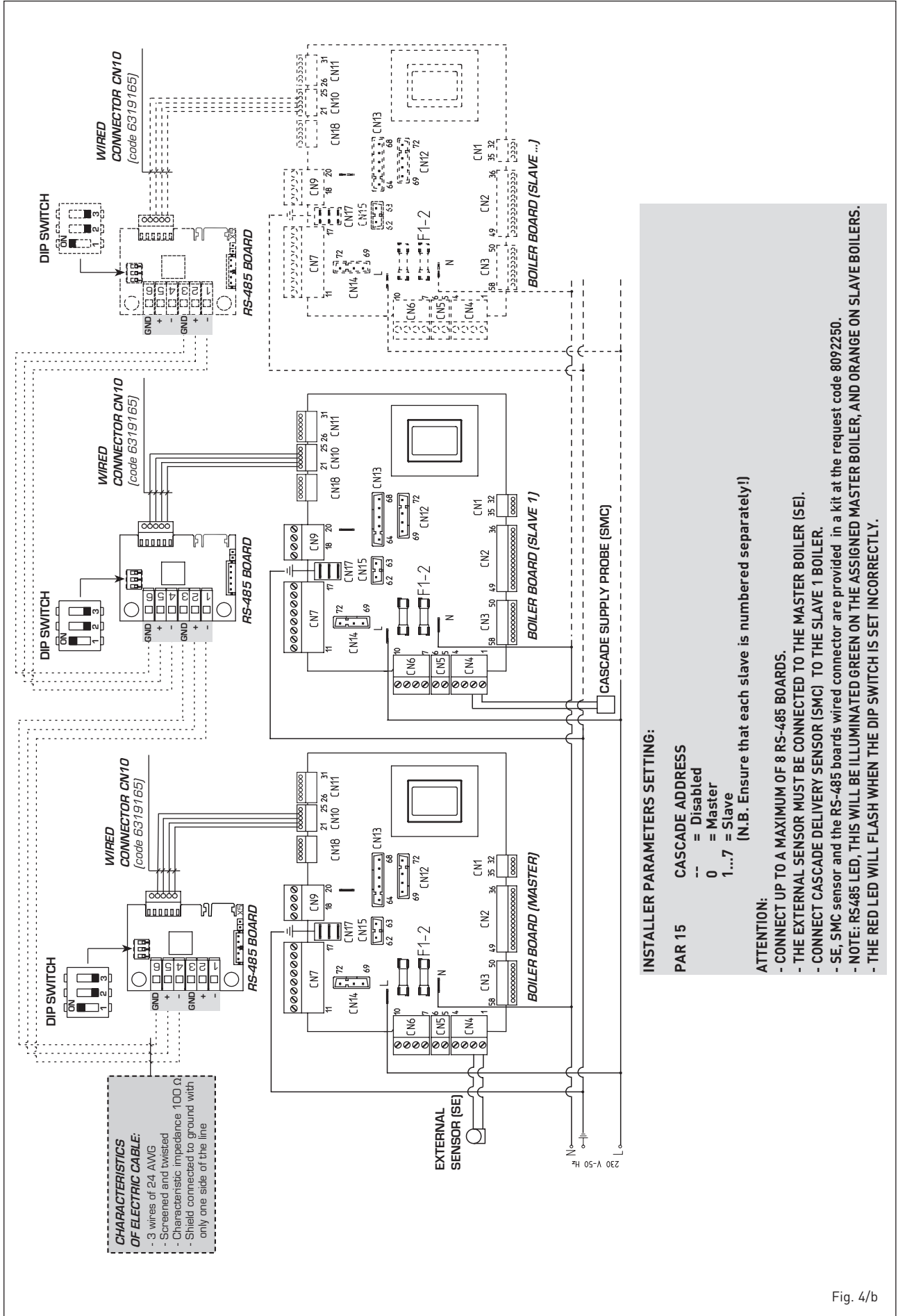

Fig. 4/b

### MODBUS mode (fig. 4/c)

The RS-485 board can be used for MODBUS communication of every MURELLE HE 50 R ErP boiler.

In this case, proceed as follows:

- Set the DIP SWITCH of the RS-485 board and the PAR 16 as indicated in the figure.

- Choose the communication configuration suited to the MODBUS network (PAR 17 INST) according to **Table PAR 17 INST**.

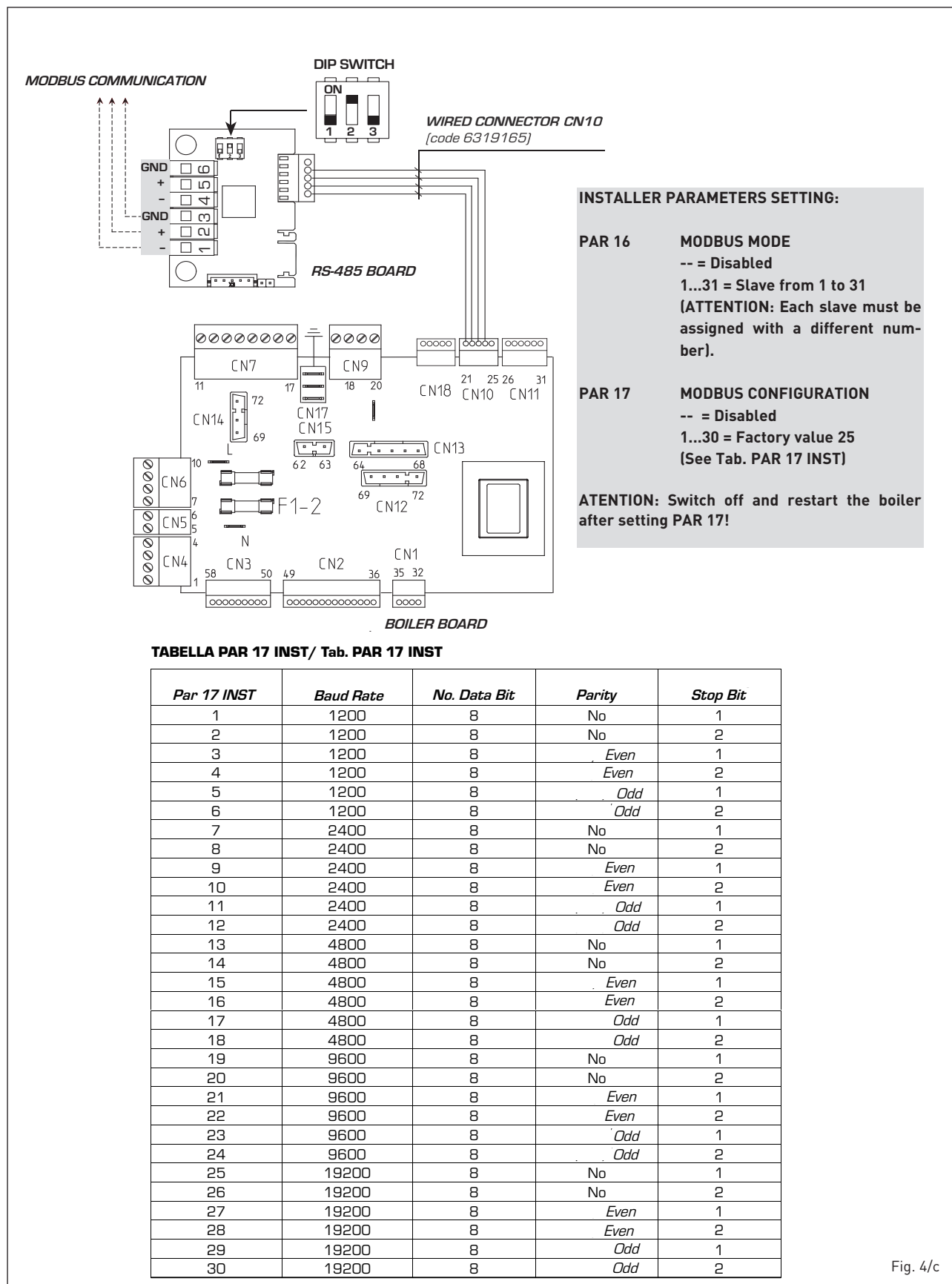

Fig. 4/c

MODBUS BOILER VARIABLES LIST							
Modbus address	Variable description	Type	Read / Write	U.M.	Min value	Max value	Function
<b>Digital variables</b>							
1	Boiler CH Enable/Request	D	R/W	-	0	1	Request CH zone 1
2	Boiler DHW Enable	D	R/W	-	0	1	Enable DHW preparation
3	Boiler Water Filling Function	D	R/W	-	0	1	Not used
32	Boiler CH Mode	D	R	-	0	1	State CH zone 1
33	Boiler DHW Mode	D	R	-	0	1	State preparation DHW
34	Boiler Flame Status	D	R	-	0	1	State presence flame
35	Boiler Alarm Status	D	R	-	0	1	State presence alarm
<b>Analog variables</b>							
1	Boiler CH Primary Setpoint	A	R/W	0,1°C	20,0	80,0	Setpoint CH zone 1. If you receive a value out of range so the value isn't received and the boiler temperature control is maintained of fixed point or a temperature curve.
2	Boiler DHW Primary Setpoint	A	R/W	0,1°C	20,0	80,0	Setpoint CH during ACS preparation (for PAR 66 installer parameters)  If you receive a value out of range the value isn't received and it is used the boiler value regulation .
3	Boiler DHW Setpoint	A	R/W	0,1°C	10,0	80,0	Setpoint ACS. If you receive a value out of range the value isn't received and it is used the boiler value regulation.
4	Outside Temperature MB	A	R/W	0,1°C	-55,0	95,0	External value of temperature by MobBus. If you receive a value out of range the value isn't received. In case of conflict the boiler will give priority to the value of the probe connected to it.
5	Boiler CH Curve Slope	A	R/W	0,1	3,0	40,0	Slope of heating curve of zone 1 (it is used instead of the curve set in the boiler). If you receive a value out of range the value isn't received and it is used the boiler heating curve.
6	Boiler CH Curve Displacement	A	R/W	0,1	-5,0	5,0	Shift value of room zone 1 set (it is used instead of the shift set in the boiler). If you receive a value out of range the value isn't received and it is used the boiler heating curve.
64	Boiler DHW Water Temperature	A	R	0,1°C	0,0	100,0	DHW temperature sensor
65	Boiler Primary Water Temperature	A	R	0,1°C	0,0	100,0	CH temperature sensor (Delivery)
66	Boiler Return Water Temperature	A	R	0,1°C	0,0	100,0	CH temperature sensor (Return)
67	Boiler Flue Gas Temperature	A	R	0,1°C	0,0	200,0	Smoke temperature sensor
68	Boiler Relative Modulation Level	A	R	0,1%	0,0	100,0	Modulation level: (0%= minimum boiler power 100%= maximum boiler power)
69	Boiler Primary Water Pressure	A	R	0,1 bar	0,0	6,0	Pressure value water CH
70	Boiler Outside Temperature	A	R	0,1°C	-100,0	100,0	Outside temperature read from the boiler through the probe connected to it
<b>Integer variables</b>							
129	Boiler Current Minute	I	R/W	-	0	59	Not used
130	Boiler Current Hour	I	R/W	-	0	23	Not used
131	Boiler Current Day of the Week	I	R/W	-	1 = Lun 7 = Dom		Not used
132	Boiler Current Day of the Month	I	R/W	-	1	31	Not used
133	Boiler Current Month	I	R/W	-	1	12	Not used
134	Boiler Current Year	I	R/W	-	2000	2200	Not used
192	Boiler Alarm Code	I	R	-	0	100	Numeric code shown during boiler error (If Master is in cascade)
193	Boiler Slave 1 Alarm Code	I	R	-	0	100	Numeric code shown during slave 01 error
194	Boiler Slave 2 Alarm Code	I	R	-	0	100	Numeric code shown during slave 02 error
195	Boiler Slave 3 Alarm Code	I	R	-	0	100	Numeric code shown during slave 03 error
196	Boiler Slave 4 Alarm Code	I	R	-	0	100	Numeric code shown during slave 04 error
197	Boiler Slave 5 Alarm Code	I	R	-	0	100	Numeric code shown during slave 05 error
198	Boiler Slave 6 Alarm Code	I	R	-	0	100	Numeric code shown during slave 06 error
199	Boiler Slave 7 Alarm Code	I	R	-	0	100	Numeric code shown during slave 07 error
200	Boiler Combustion Parameter (Par1)	I	R	-	0	199	PAR 1 value
201	Boiler Hydraulic Parameter (Par2)	I	R	-	0	199	PAR 2 value

### CASCADE+MODBUS mode (fig. 4/d)

This mode allows for MODBUS communication of at least two boilers in cascade and is performed by requesting another RS-485 board provided in the kit code 8092244.

**ATTENTION: Communication will occur only with the MASTER boiler, (boiler with PAR 15 = 0), interpreting the cascade as a single heat capacity generator: P CASCADE = P BOILER x No. BOILERS.**

To install the second board, proceed as follows:

- Remove the cover and electrical-ly connect the second RS-485 board equipped with lid to the RS-485 board already installed in the MASTER boiler (boiler with PAR 15 = 0) with the wired connector provided in the kit.
- CAUTION: Insert the wired connector with caution.**
- Set the DIP SWITCH of the new board in MODBUS mode.
- Close the lid of the second board.
- Choose the communication configuration suited to the MODBUS network (PAR 17 INST) according to **Table PAR 17 INST**.

### RS-485 connection to the INSOL/MIXED ZONE (fig. 4/e)

The RS-485 board can be connected to optional INSOL kit code 8092254 or MIXED ZONE code 8092252. Both require the board housing kite code 8092236. Carry out the electrical connections as indicated in the figure.

**CAUTION: For electrically connecting the INSOL/MIXED ZONE board to the boiler board, refer to the instruction leaflet provided in the kit.**

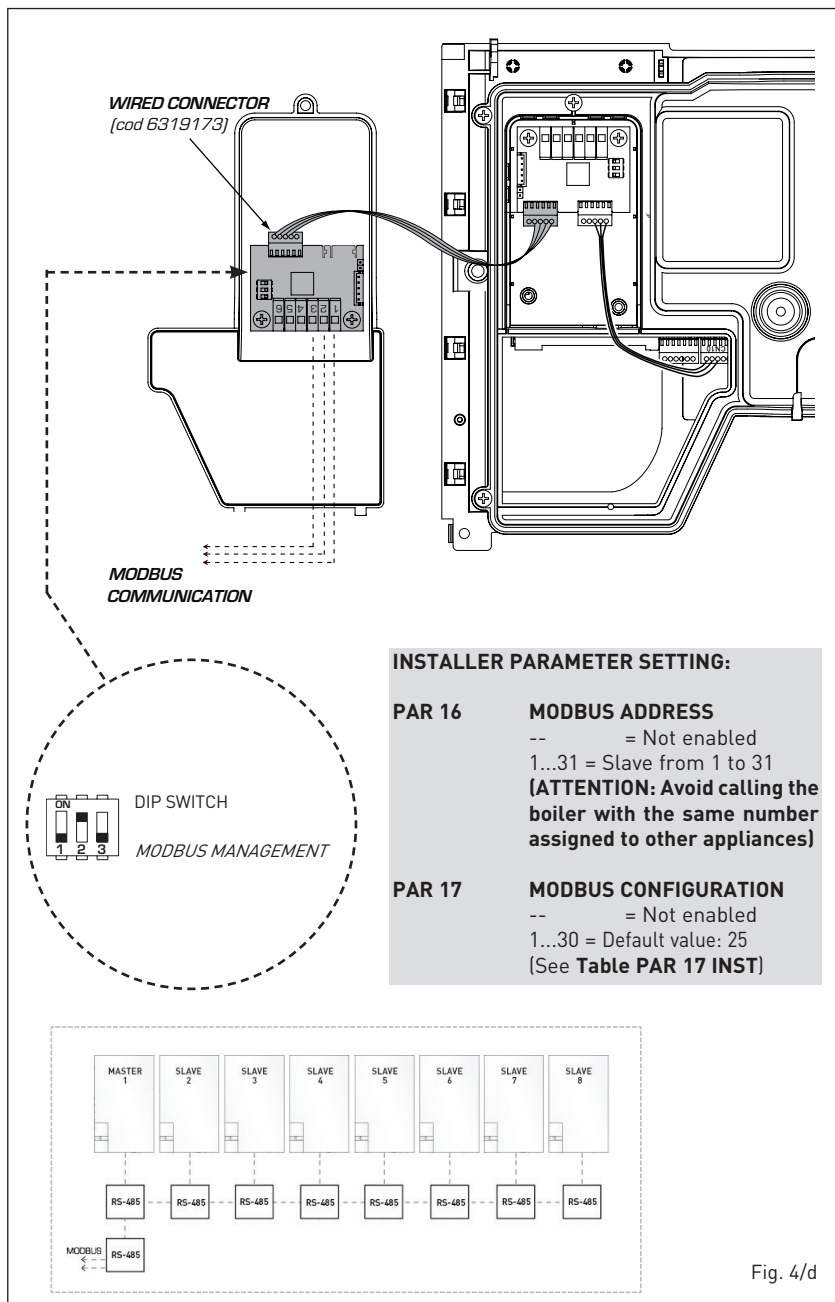

**INSTALLER PARAMETER SETTING:**

<b>PAR 16</b>	<b>MODBUS ADDRESS</b>
--	= Not enabled
1...31	= Slave from 1 to 31
	<b>(ATTENTION: Avoid calling the boiler with the same number assigned to other appliances)</b>
<b>PAR 17</b>	<b>MODBUS CONFIGURATION</b>
--	= Not enabled
1...30	= Default value: 25
	(See Table PAR 17 INST)

Fig. 4/d

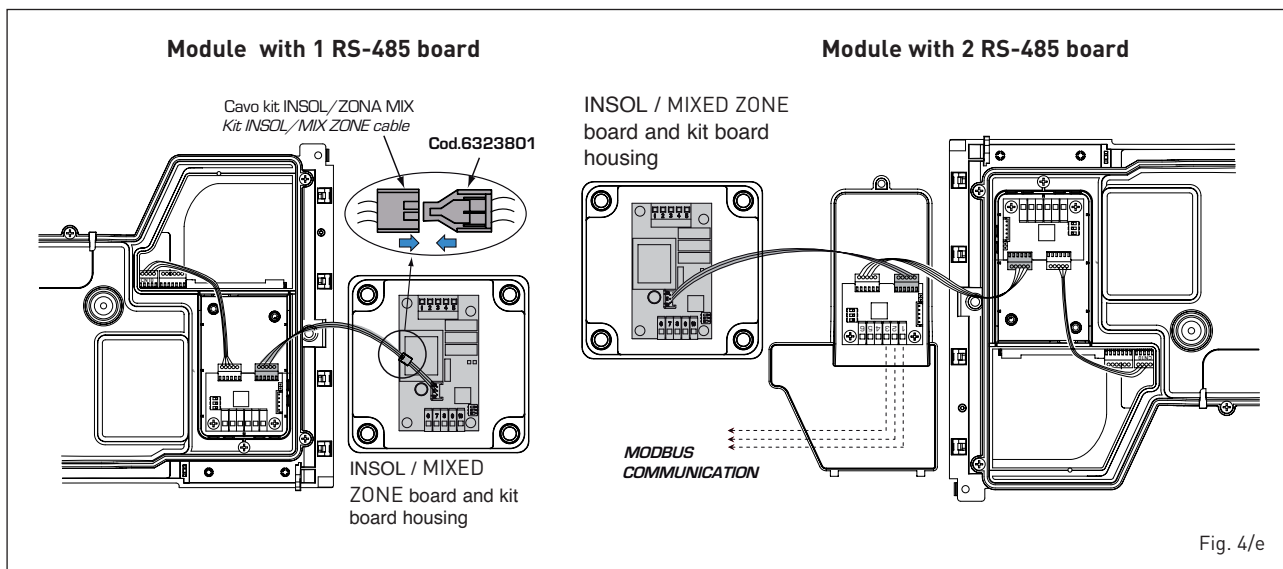

Fig. 4/e

### 2.3 CONNECTING UP SYSTEM

To protect the heat exchanger becoming damaged by corrosion, incrustation or deposits, after installation it is extremely important to clean the system using suitable products. Sime recommend the use of FERNOX products for the flushing and final treatment of the system water. this is particularly important in hard water areas.

Artificially softened water must not be used to fill the heating system.

It is important to check the concentration of the inhibitor after each system modification and during maintenance, following the product manufacturers instructions (specific test kits are available).

A suitable connection must be made to the safety valve, extending it to a safe termination, incorporating a tun dish if required.

Isolation valves must be incorporated in the heating flow and return, to enable boiler maintenance or repair without the need to drain the entire heating system.

#### WARNING:

**Failure to clean , or adequately treat the heating system could invalidate the boiler warranty.**

Gas connections must be made in accordance with current standards and regulations. When dimensioning gas pipes from the meter to the module, both capacity volume (consumption) in m<sup>3</sup>/h and gas density must be taken into account.

The sections of the piping making up the system must be such as to guarantee a supply of gas sufficient to cover the maximum demand, limiting pressure loss between the gas meter and any apparatus being used to not greater than:

- 1.0 mbar for family II gases (natural gas);
- 2.0 mbar for family III gases (butane or propane).

An adhesive data plate is positioned inside the front panel; it contains all the technical data identifying the boiler and the type of gas for which the boiler is arranged.

#### 2.3.1 Connection of condensation water trap

To ensure safe disposal of the condensate produced by the flue gases, reference should be made to BS6798:2009. The boiler incorporates a condensate trap which has a seal of 75mm, therefore no additional trap is required. The condensate should ideally be discharged internally into an internal waste pipe (washing machine/ sink waste) or a soil pipe to avoid the risk

of freezing. External pipe runs should be avoided, but if it is necessary, the pipework should be at least 32 mm and protected from the risk of freezing with a waterproof insulation and the length kept to a minimum and not exceeding 3 m. termination should be into an external gully or purpose made soakaway. We recommend that the condensate drain at the boiler is in 20 mm solvent weld pipe with a socket covering the connection to the trap. Alternatively a suitable hose can be secured to the trap and terminated as required (see Appendix 1- Dealing with condensate).

**NOTE: All pipework must have a continuous fall from the boiler and must be resistant to corrosion by condensate,**

copper or steel is NOT suitable. It should be noted that the connection of a condensate pipe to a drain may be subject to local building control requirements.

#### 2.3.2 Filter on the gas pipe

The gas valve is supplied ex factory with an inlet filter, which, however, is not adequate to entrap all the impurities in the gas or in gas main pipes.

To prevent malfunctioning of the valve, or in certain cases even to cut out the safety device with which the valve is equipped, install an adequate filter on the gas pipe.

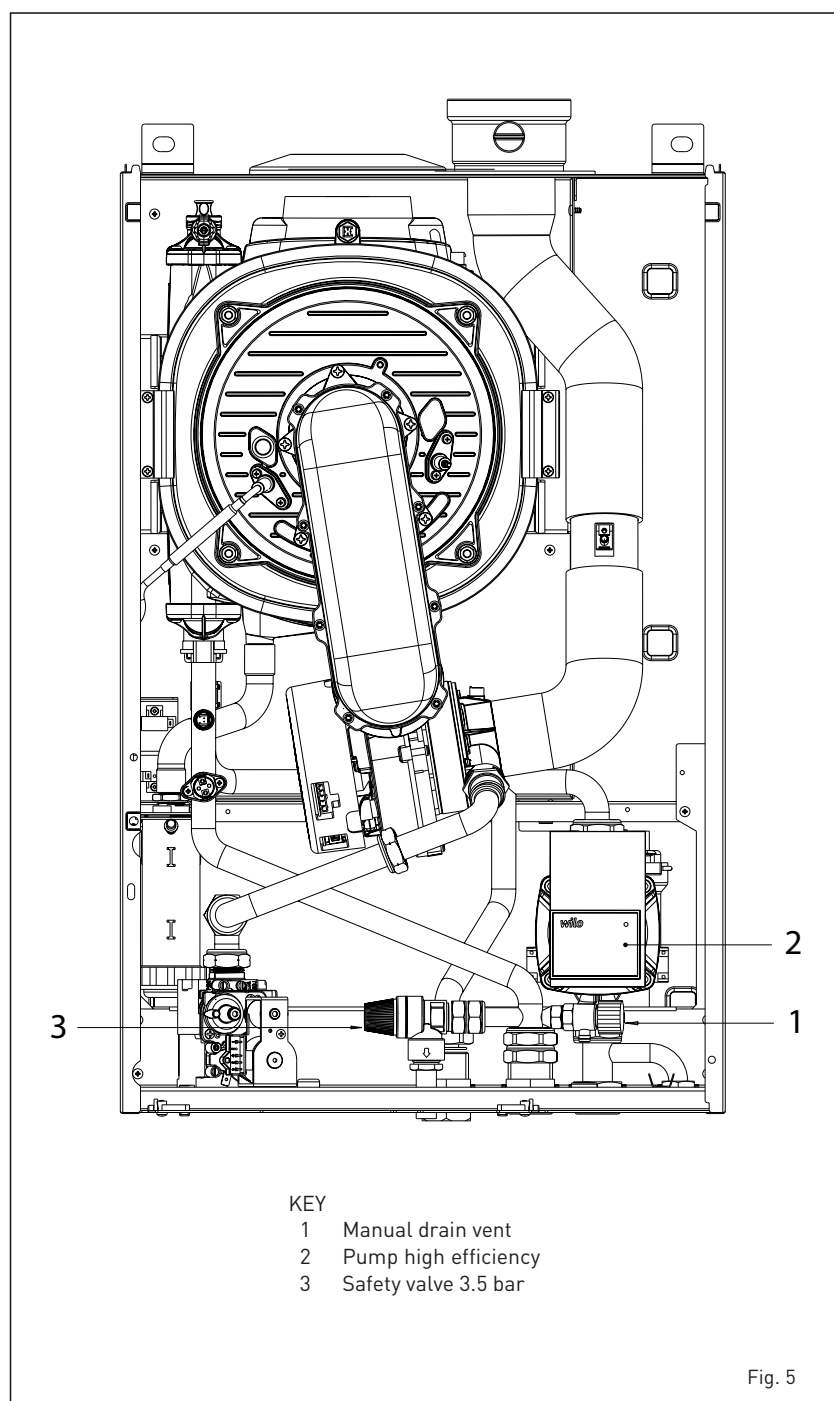

Fig. 5

## 2.4 INITIAL PHASE SYSTEM FILLING (fig. 5)

Cold system filling pressure must be **1 bar**. The system must be filled slowly so that air is released through the specific escapes.

### 2.4.1 System draining (fig. 5)

To drain the system, turn off the boiler, isolate the flow and return, and use the boiler drain vent (1 fig. 5).

### 2.4.2 Dealing with condensate

See Appendix 1 "Dealing with condensate"

### 2.4.3 Requirements for sealed water systems MURELLE HE 50 R ErP (fig. 5/b)

The heating system design should be based on the following information:

- The available pump head is given in fig. 14.
- A filling device as shown in fig 5/b must be incorporated.

## 2.5 EXHAUST

The boiler is supplied with a 80 mm

gasket, which must be fitted over the exhaust terminal prior to the flue being installed (11 fig. 6 - fig. 7 - fig. 8). See fig 8a for examples of suitable flue termination positions.

### 2.5.1 Type B (fig. 6)

If the inlet is not connected, the boiler should be regarded a **Type B** device. When installing the boiler in locations where it needs to be protected from water, replace the intake terminal inserted in the flange with terminal code 8089510.

For information on how to configure the boiler in this mode see figure 6.

**The maximum overall length of  $\varnothing$  80 exhaust flues is determined by the load losses of the single accessories installed and should not exceed 16 mmH<sub>2</sub>O.**

The exhaust pipe can be connected to existing chimneys.

When the boiler works at low temperature is possible to use normal chimneys at the following conditions:

- The chimney must not be used by other boilers.
- The inside of the chimney must be protected from direct contact with the boiler condensation. Combustion products must be conveyed with a flexible piping or rigid plastic pipes with a diameter of about 100-150 mm providing so to the condensation siphoned drainage at the end of the pipe. The useful height of the siphon must be at least 150 mm.

### 2.5.2 Type C (fig. 7 - fig. 8)

The boiler becomes a **Type C** device when the intake terminal is removed from the flange and the intake is connected to separate exhaust ducts (fig. 7) or with coaxial exhaust (fig. 8).

### 2.5.3 Maximum usable length for separate $\varnothing$ 80 flues

**The maximum overall length of  $\varnothing$  80 suction and exhaust flues is determined by the load losses of the single accessories installed and should not exceed 16 mmH<sub>2</sub>O.**

When the segment of piping is between 11-16 mm H<sub>2</sub>O it is necessary to check and, if needed, re calibrate the gas valve as specified in point 4.2.2.

### 2.5.4 Maximum usable length for coaxial $\varnothing$ 80/125 flues

**In installations with  $\varnothing$  80/125 coaxial exhaust, the maximum horizontal length including the 90° elbow, should not exceed 5 m.**

**For roof exits it should not exceed 8 m along vertical.**

When the segment of pipe is between 2-5 m horizontal / 4-8 m vertical, it is necessary to check and, if needed, re calibrate the gas valve as specified in point 4.2.2.

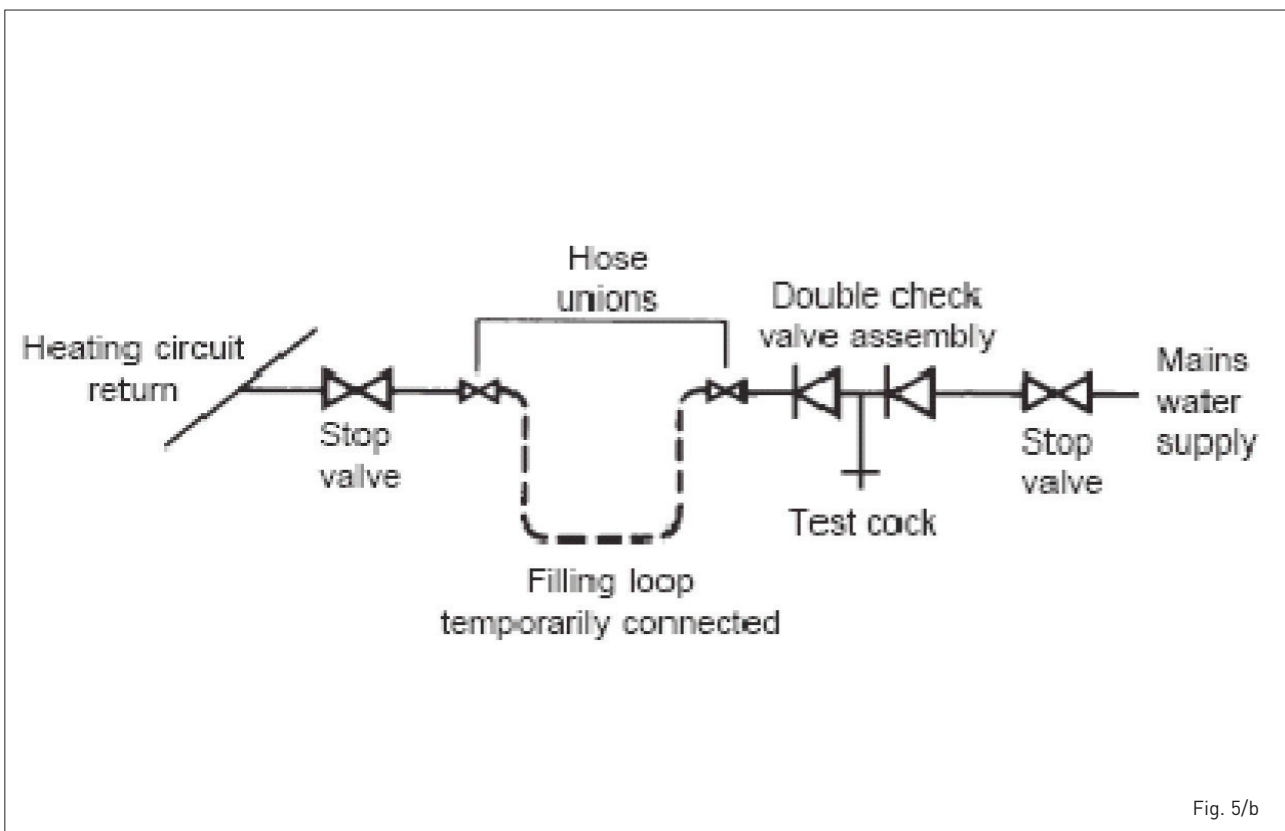
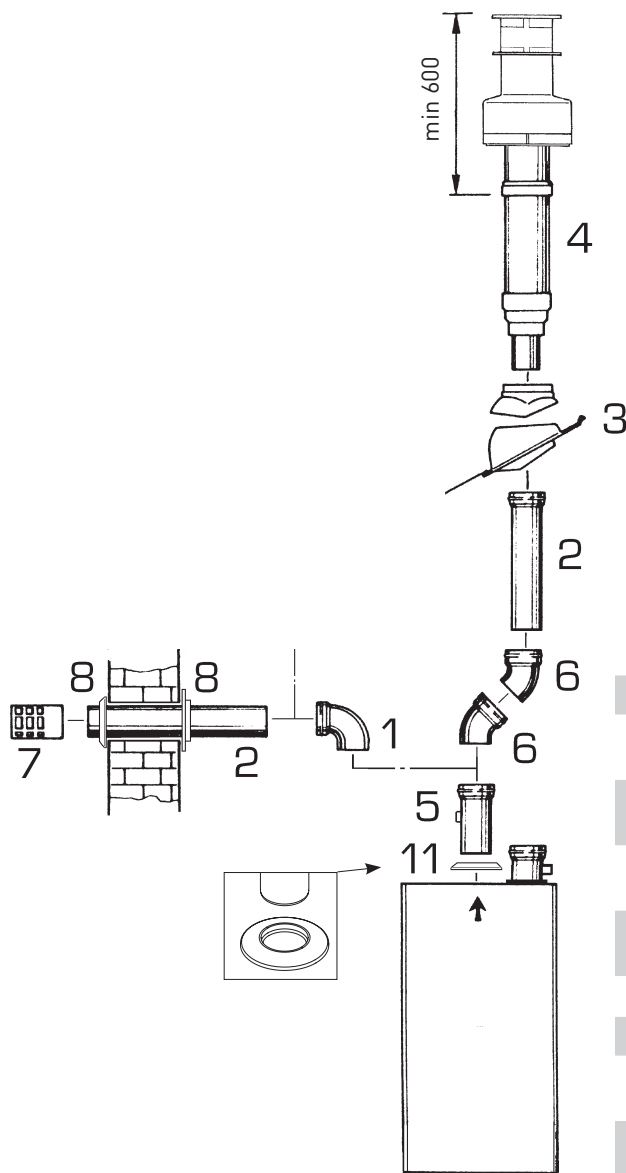

Fig. 5/b

## Type B



### 80 mm accessories

Key	Code	Description	Load loss mm H <sub>2</sub> O
1	8077450A (single) 8077450 (6 pieces)	90° bend	0,8
2a	8077351A (single) 8077351 (6 pieces)	1000mm Extension	0,4
2b	8077350A (single) 8077350 (6 pieces)	500mm Extension	0,2
3	8091300	Articulated Tile	
4	8091212B	Roof terminal (1381mm)	1,3
5	6296513	Extension with test point (250mm)	0,1
6	8077451A (single) 8077451 (6 pieces)	45° bend	0,4
7	8089501	Exhaust terminal	1,5
8	8091500	Inner/outer wall seal (2 of each)	
11		Gasket (supplied with boiler)	

### WARNING:

Before installing accessories, lubricate the internal part of gaskets with silicon-based products. Avoid using oils and greases.

Fig. 6



### Type C (separate $\varnothing$ 80 flues)

### Type C (separate $\varnothing$ 80 flues and coaxial exhaust terminal)

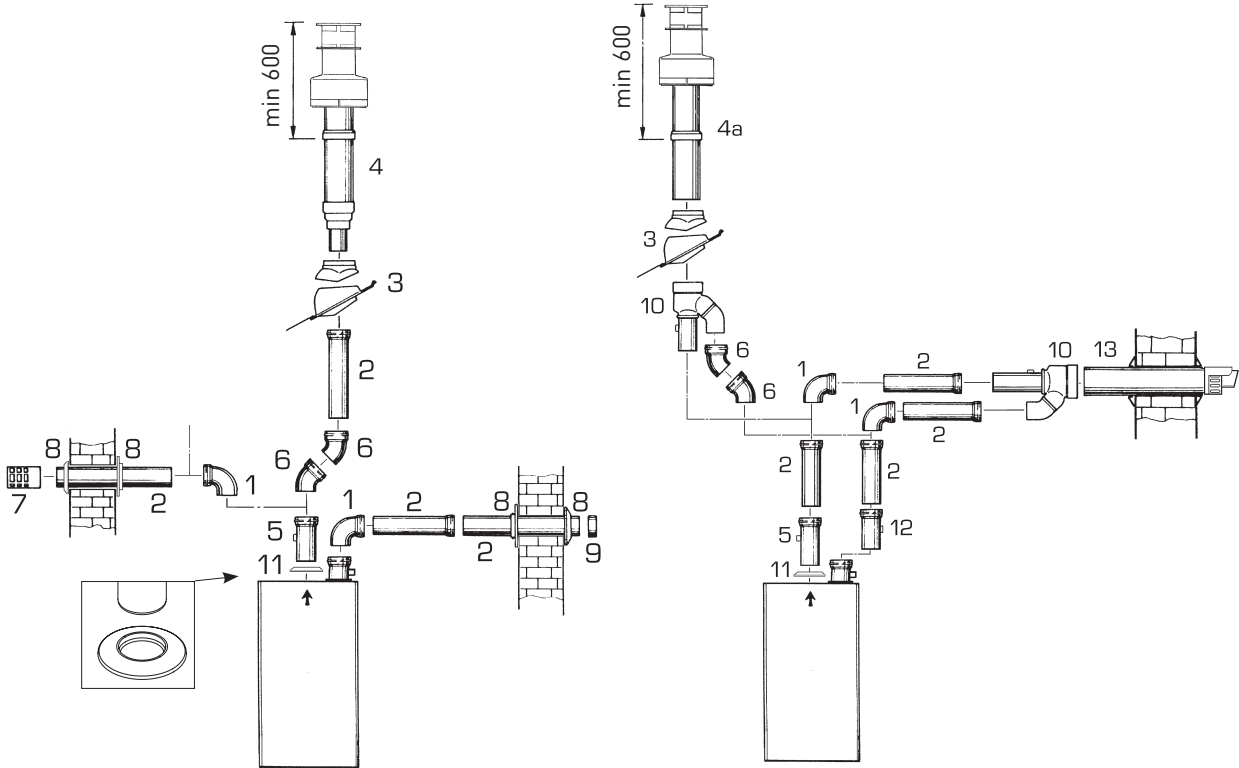

#### 80 mm accessories

Key	Code	Description	Load loss mm	
			Inlet	Exhaust
			H <sub>20</sub>	
1	8077450A (single) 8077450 (6 pieces)	90° bend - 80 mm	0,8	0,8
2a	8077351A (single) 8077351 (6 pieces)	1000mm Extension - 80mm	0,35	0,45
2b	8077350A (single) 8077350 (6 pieces)	500mm Extension - 80mm	0,15	0,2
3	8091300	Articulated Tile	-	-
4	8091212B	Roof terminal (L 1381mm)	-	1,3
4a	8091212B	Coaxial roof exit terminal	-	4,0*
5	6296513	Extension with test point(L 250mm)	-	0,1
6	8077451A (single) 8077451 (6 pieces)	45° bend - 80mm	0,45	0,45
7	8089501	Exhaust terminal - 80mm	-	1,5
8	8091500	Inner/outer wall seal (2 of each)	-	-
9	8089500	Inlet terminalm - 80mm	0,2	-
10	8091401	Inlet/ exhaust fitting	-	-
11		Gasket (supplied with boiler)	-	-
13	8091210	Coaxial exhaust $\varnothing$ 80/125 L.885	-	5,0*

\* This loss includes the losses of item 10

#### WARNING:

- Installations with roof exit terminal (4a) and coaxial exhaust (13) require the use of a condensation recovery (12) that has to be connected to the water drain siphon (waste water).
- Before installing accessories, lubricate the internal part of gaskets with silicon-based products. Avoid using oils and greases.

Fig. 7

## Type C (ø 80/125 coaxial exhaust)

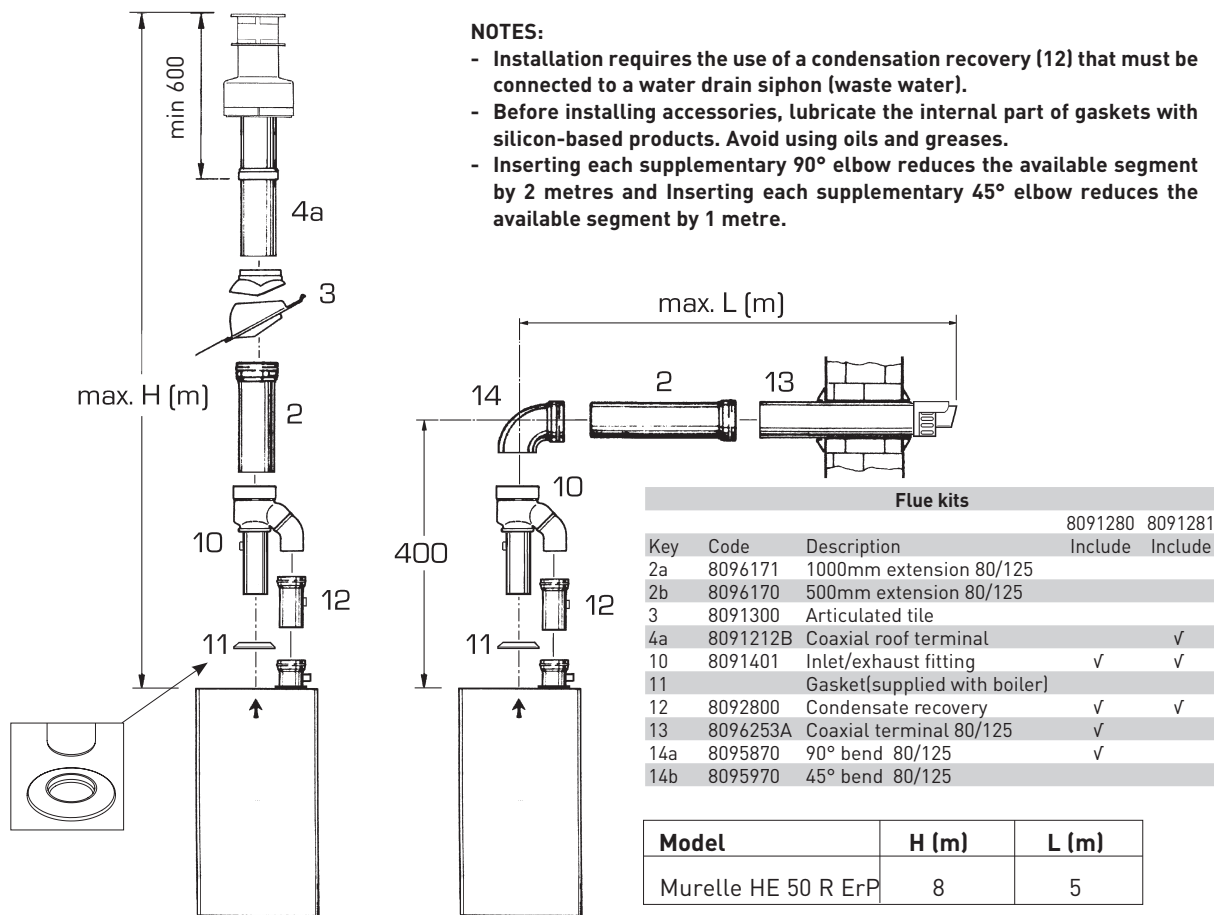

Fig. 8

### 2.5 ELECTRICAL CONNECTION

The boiler is supplied with an electric cable. Should this require replacement, it must be purchased exclusively from SIME.

The electric power supply to the boiler must be 230V - 50Hz single-phase through a 3 A fused main switch, with at least 3 mm spacing between contacts. Respect the L and N polarities and the earth connection.

**NOTE: SIME declines all responsibility for injury or damage to persons, animals or property, resulting from the failure to provide for proper earthing of the appliance.**

#### 2.5.1 Room thermostat and/or Timer (clean contact)

The heating demand can be controlled by a thermostat and/or timer (TA) connected to CN6 terminals 7-8 (see fig 11) after having removed the existing bridge. The control

being used must be of a class conforming to the standard EN 607301 (clean electrical contact).

#### 2.5.2 Remote control SIME HOME connection (optional)

The boiler is designed for connection to a remote control unit SIME HOME, supplied on request (code 8092280/81). The remote control unit SIME HOME allows for complete remote control of the boiler. The boiler display will show the following message:

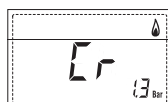

For installation and use of the remote control, follow the instructions in the package.

**NOTE: Ensure PAR 10 set to 1 (PAR 10 = 1).**

#### 2.5.3 External sensor connection

The boiler is designed for connection to

an external temperature sensor, supplied on request (code 8094101), which can automatically regulate the temperature value of the boiler output according to the external temperature. For installation, follow the instruction in the package. It is possible to make corrections to the values read by adjustment of **PAR 11**.

#### 2.5.3 Heat Demand by 230v

The heating demand can be controlled by 230v applied to terminal 14 on CN7, and removal of the bridge on CN6 terminals 7 & 8.

#### 2.5.5 BMS (Building Management Systems)

Single or cascade boilers can be integrated into a building management system. The BMS signal should be connected to the single, or master boiler as shown in fig11.

Set PAR14 according to the maximum (10v) flow temperature required.

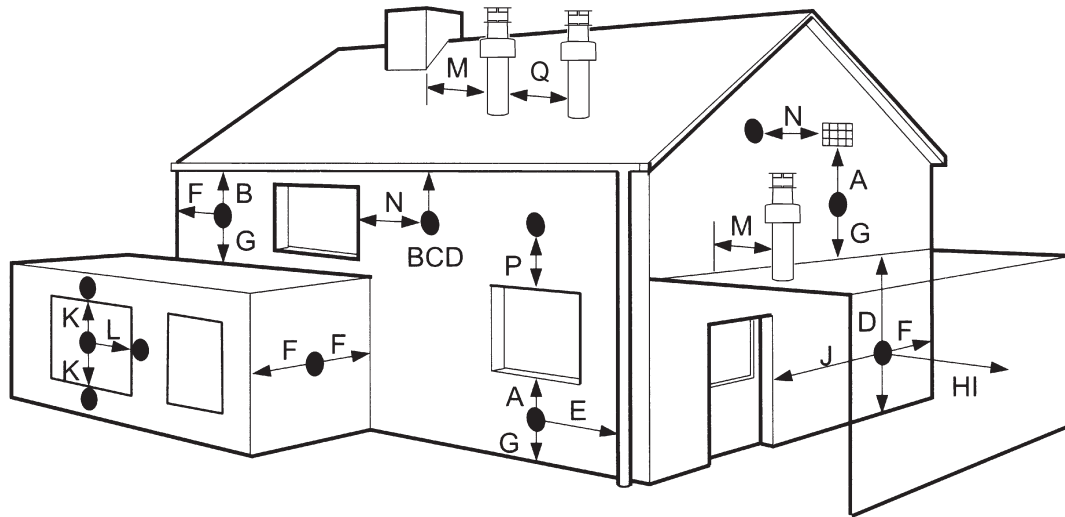

TABLE 2

Terminal position	Minimum spacing
A Directly below an openable window, air vent or any other ventilation opening	300 mm 12 in
B Below guttering, drain pipes or soil pipes	75 mm 3 in
C/D Below eaves, balconies or carport roof (*)	200 mm 8 in
E From vertical drain pipes or soil pipes	75 mm 3 in
F From internal or external corners	300 mm 12 in
G Above adjacent ground, roof or balcony level	300 mm 12 in
H From a boundary or surface facing the boiler	600 mm 24 in
I From a terminal facing the terminal	1,200 mm 48 in
J From an opening in the carport (eg door, window into dwelling)	1,200 mm 48 in
K Vertically from a terminal on the same wall	1,500 mm 60 in
L Horizont. from a terminal on the same wall	300 mm 12 in
M Horizont. from a vertical terminal to a wall	300 mm 12 in
N Horizont. from an openable window or other opening	300 mm 12 in
P Above an openable window or other opening	300 mm 12 in
Q From an adjacent vertical terminal	600 mm 24 in

(\*) Note: this can be reduced to 25 mm, but it would be necessary to protect the surfaces from the effects of condensate.

- If the terminal discharges into a pathway or passageway check that combustion products will not cause nuisance and that the terminal will not obstruct the passageway.
- Where the lowest part of the terminal is fitted less than 2 m (78 in) above ground, above a balcony or above a flat roof to which people have access, the terminal MUST be protected by a purpose designed guard.
- Where the terminal is fitted within 850 mm (34 in) of a plastic or painted gutter, or 450 mm (18 in) of painted eaves, an aluminium shield at least 1,500 mm (59 in) long must be fitted to the underside of the painted surface.
- The air inlet/outlet flue duct MUST NOT be closer than 25 mm (1 in) to combustible material.
- In certain weather conditions the terminal may emit a plume of steam. This is normal but positions where this would cause a nuisance should be avoided.

## 2.7 BOILER ELECTRICAL (fig. 11)

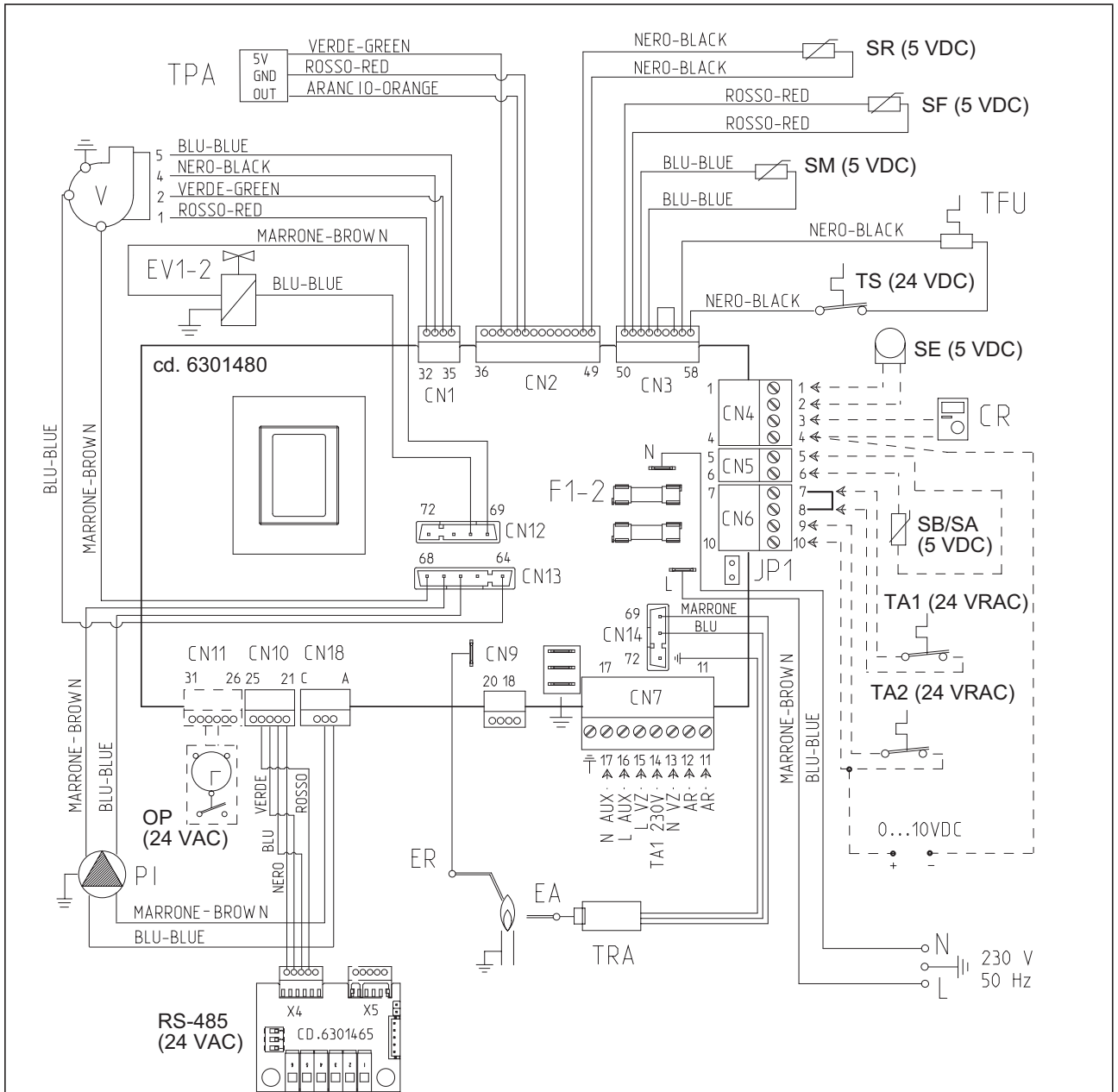

- KEY**
- F1-2 Fuse (4 AT)
  - TRA Ignition transformer
  - PI Pump high efficiency
  - V Fan
  - EA Ignition electrode
  - ER Ionisation electrode
  - EV1-2 Gas valve coil
  - TS Safety thermostat
  - SF Exhaust temperature sensor
  - TFU Thermal fuse
  - SM Heating flow sensor
  - SR Heating return sensor
  - TPA Pressure transducer
  - JP1 Selection TA2 or 0-10 VDC (See note below)

- TA1 Zone 1 environment thermostat
- TA2 Zone 2 environment thermostat
- SB D.H.W. sensor L. 2000 (optional)
- CR Remote control
- SIME HOME (optional)
- SE External sensor (optional)
- OP Programming clock (optional)
- AR Remote alarm
- VZ Zone valve
- AUX Auxiliary connection
- RS-485 CASCADE/MODBUS board
- SA Frost detector (external version only)

**NOTE: Connect TA1 to the clamps 7-8 after having removed the bridge.**

**CONNECTOR SPARE PART CODES:**

- CN1** code 6319162
- CN2** code 6319160
- CN3** code 6319164
- CN4** code 6316203
- CN6** code 6316202
- CN7** code 6316204
- CN10** code 6319165
- CN12** code 6299991
- CN13** code 6319161
- CN14** code 6319163
- CN18** code 6319147

**NOTE - JP1 link**

With JP1 link fitted TA2 input is by operation of a clean contact.

For operation by a BMS (0-10v dc) signal, JP1 must be removed, TA1 link fitted and the BMS connected, +ve to terminal 10 - CN6, -ve to terminal 4 - CN4.

PAR 14 will require setting to the maximum flow temperature required."

Fig. 11

### 3 CHARACTERISTICS

#### 3.1 CONTROL PANEL (fig. 12)

#### DESCRIPTION OF DISPLAY ICONS

- SUMMER MODE ICON**
- WINTER MODE ICON**
- D.H.W. MODE ICON**
- HEATING DEMAND ICON**
- GRADED POWER SCALE**  
The segments of the bar light up in proportion to boiler power output .
- BURNER FUNCTIONING AND LOCKOUT ICON**
- RESET REQUIRED ICON**
- CHIMNEY SWEEP ICON**
- SECONDARY DIGITS**  
The boiler visualises the value of the pressure of the system (correct value is between 1 and 1.5 bar)
- MAIN DIGITS**  
The boiler visualises the values set, the state of anomaly and the external temperature
- INTEGRATIVE SOURCES ICON**

#### 2 - DESCRIPTION OF CONTROLS

- ON/OFF KEYS**  
ON = Electricity supply to boiler is on  
OFF = Electricity supply to boiler is on but not ready for functioning. However, the protection functions are active.
- SUMMER MODE KEY**  
When this key is pressed, the boiler functions only when D.H.W. is requested **(function not available)**
- WINTER MODE KEY**  
When this key is pressed, the boiler provides heating and D.H.W.
- D.H.W. TEMP KEY**  
When this key is pressed, the temperature of the D.H.W. is shown on the display **(function not available)**
- HEATING TEMP KEY**  
The first time the key is pressed, the temperature of heating circuit 1 is shown.  
The second time the key is pressed, the temperature of heating circuit 2 is shown.  
The third time the key is pressed, the temperature of heating circuit 3 is shown (3-zone system).
- RE-SET KEY**  
This allows for restoring functioning after a functioning anomaly.
- INCREASE AND DECREASE KEY**  
By pressing this key the set value increases or decreases.

#### 3 - KEYS RESERVED FOR THE INSTALLER (access to INST and OEM parameters)

- PC CONNECTION**  
To be used only with the SIME programming kit and only by authorised personnel. Do not connect other electronic devices (cameras, telephones, mp3 players, etc.) Use a tool to remove the cap and reinsert after use.  
**ATTENTION: Communication port sensitive to electrostatic charges.**
- INFORMATION KEY**  
This key can be pressed several times to view the parameters.
- CHIMNEY SWEEP KEY**  
This key can be pressed several times to view the parameters.
- DECREASE KEY**  
This key changes the default settings.
- INCREASE KEY**  
This key changes the default settings.

#### 4 - LUMINOUS BAR

- Blue = Functioning
- Red = Functioning anomaly











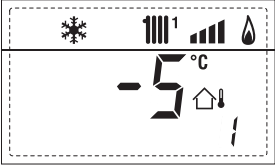
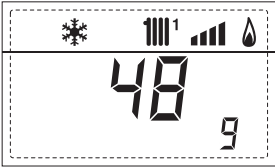

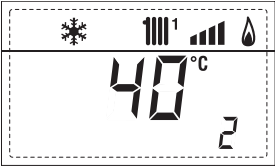
#### 5 - PROGRAMMING CLOCK (optional)

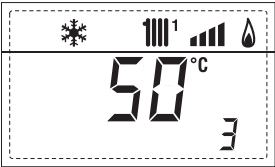
- Mechanical clock (code 8092228) or digital clock (code 8092229) to program heating [single zone only].

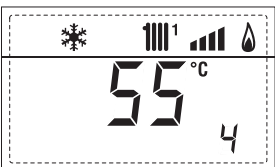
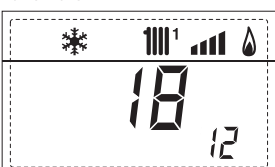
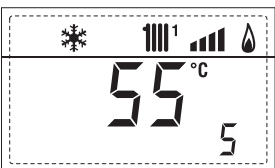
Fig. 12

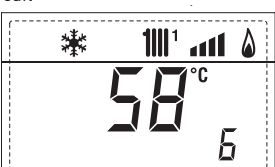
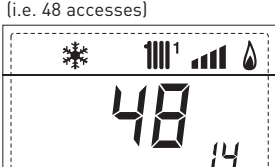
### 3.2 ACCESS TO INSTALLER'S INFORMATION

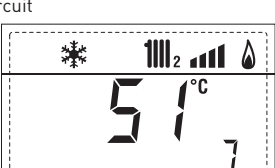
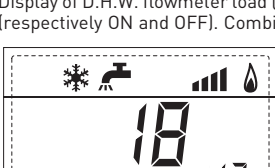
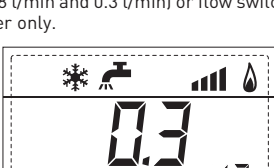
For access to information for the installer, press the key (3 fig. 14). Each time the key is pressed, the display moves to the next item of information. If expansion boards (MIXED ZONE o INSOL) are connected, the related info will be displayed. If the key is not pressed, the system automatically quits the function. Please note the first press of any key acts to illuminate the display only.

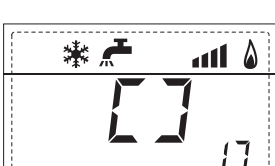
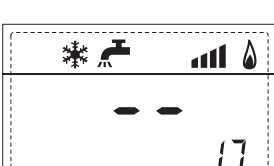
- |   |  |  |
|---|--|--|
| <p>1. Display of external temperature, only when external sensor connected</p>       | <p>9. Display fan speed in rpm x 100 (e.g. 4.800 and 1850 rpm)</p>    |   |
| <p>2. Display of heating flow temperature sensor (SM)</p>                            | <p>10. Display of number of hours of functioning of the burner in h x 100 (e.g. 14000 and 10)</p>   |   |
| <p>3. Display of D.H.W. temperature sensor (SS) only for instantaneous boilers</p>  | <p>11. Display of number of times the burner has ignited x 1000 (e.g. 97000 and 500)</p>   |    |
| <p>4. Display of auxiliary temperature sensor or D.H.W. sensor (SB)</p>            | <p>12. Display of total number of errors</p>    |  |
| <p>5. Display of exhaust temperature sensor (SF)</p>                               | <p>13. Parameter access counter-Installer (i.e. 140 accesses)</p>   |  |
| <p>6. Display of heating temperature of first circuit</p>                          | <p>14. Parameter access counter-OEM (i.e. 48 accesses)</p>    | <p>15. Access counter parameters CASCADE OEM (es. 05 access)</p>  |
| <p>7. Display of heating temperature of second circuit</p>                         | <p>17. Display of D.H.W. flowmeter load (i.e. 18 l/min and 0.3 l/min) or flow switch (respectively ON and OFF). Combi boiler only.</p>  |   |
| <p>8. Display of ionisation current in µA</p>                                      |   |   |

18. Display of heating return temperature sensor [SR]

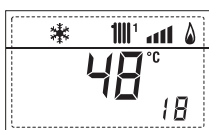

19. Display of the Cascade flow temperature value( when fitted)

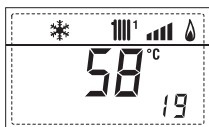

20. Display delivery probe value mixed with board MIXED ZONE 1 (input S2)

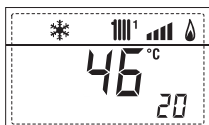

21. Display safety thermostat MIXED ZONE (input S1) respectively ON and OFF

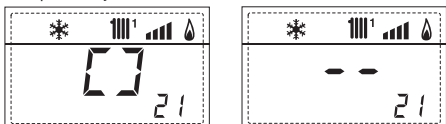

22. Display of pump operation with board MIXED ZONE (respectively ON and OFF)

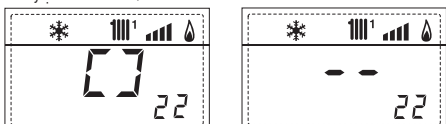

23. Display valve opening control with board MIXED ZONE (respectively ON and OFF)

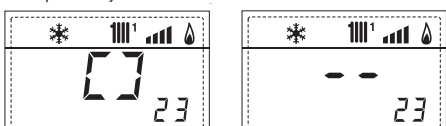

24. Display valve closing control with board MIXED ZONE (respectively ON and OFF)

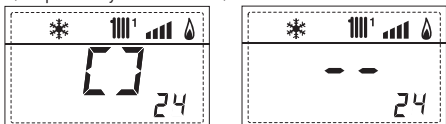

25. Display of the plant delivery probe mixed with board MIXED ZONE 2



26. Display safety thermostat with board MIXED ZONE 2 (input S1) respectively ON and OFF

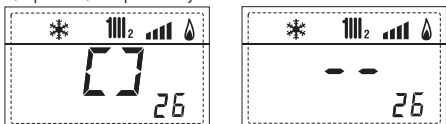

27. Display pump with board MIXED ZONE 2 (respectively ON and OFF)

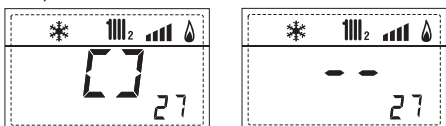

28. Display valve opening control with board MIXED ZONE 2 (respectively ON and OFF)

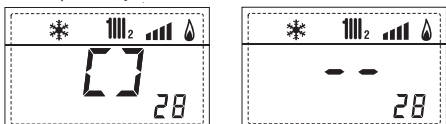

29. Display of valve operation with board MIXED ZONE 2 (respectively ON and OFF)

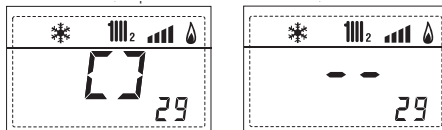

30. Display solar probe temperature value S1 with solar board INSOL

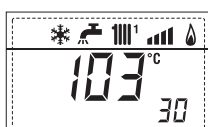

31. Display solar probe temperature value S2 with solar board INSOL

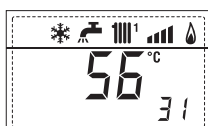

32. Display solar probe temperature value S3 with solar board INSOL

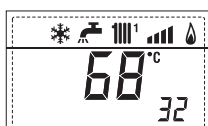

33. Display solar relay R1 with solar board INSOL (respectively ON and OFF)

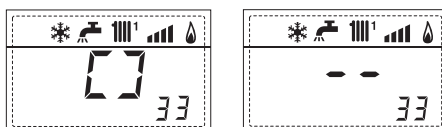

34. Display solar relay R2 with solar board INSOL (respectively ON and OFF)

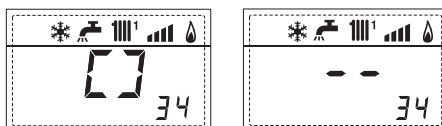

35. Display solar relay R3 with solar card INSOL (respectively ON and OFF)

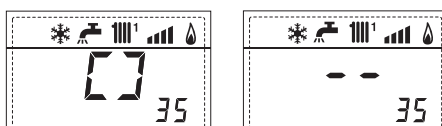

36. Display of solar flow meter state (respectively ON and OFF)

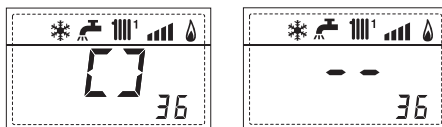

40. Display % value pump control PWM (Modulating pump version only)



45. Visualization temperature heating refers to the third circuit



60. Code of last recorded error.



61. Code of penultimate error recorded.

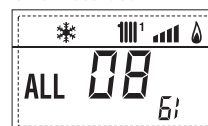

70. Warning code (see 3.3.2)



90. RS-485 software last version (es. 01 version)



91. EXP software version (configuration MIXED ZONE)



92. 2° EXP software version (configuration MIXED ZONE)





### 3.3 ACCESS TO INSTALLER'S PARAMETERS

For access to the installer's parameters, press simultaneously the keys and or 2 seconds (3 fig. 12).

For example, the parameter PAR 23 is shown on the display of the control panel in the following way:

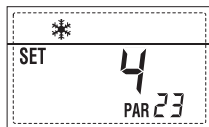

The parameters scroll forwards and backwards with the key and and the default parameters can be changed with the keys and .

The standard display returns automatically after 60 seconds, or by pressing one of the control keys (2 fig. 12).

#### 3.3.1 Replacing the board or RESETTING parameters

If the PCB is changed, or reset (PAR49), then PAR1 and PAR2 will need to be reset to the correct values, see tables below:

GAS	MODEL	PAR 1
METHANE (G20)	Single (50 R ErP)	5
	Sequence/cascade	6
PROPANE (G31)	Single (50 R ErP)	13
	Sequence/cascade	14

PARAMETERS INSTALLER					
FAST CONFIGURATION					
PAR	DESCRIPTION	RANGE	UNIT OF MEASUREMENT	INC/DEC UNIT	DEFAULT SETTING
1	Combustion configuration	-- = ND 1 ... 63	=	=	" - - "
2	Hydraulic configuration	-- = ND 1 ... 14	=	=	" - - "
3	Timetable 2 programmer	1 = DHW + Recirc. pump 2 = DHW 3 = Recirculation pump	=	=	1
4	Pressure transducer disabler	0 = Disabled 1 = Enabled 0-4 BAR 2 = Enabled 0-6 BAR 3 = Enabled 0-4 BAR (NO ALL 09) 4 = Enabled 0-6 BAR (NO ALL 09)	=	=	1
5	Assignment of auxiliary relay AUX	1 = Remote alarm NO 2 = Recirculation pump 3 = Automatic load. 4 = Remote alarm NC 5 = Heat pump 6 = Zone 2 valve	=	=	1
6	Luminous bar indicating presence of voltage	0 = Disabled 1 = Enabled	=	=	1
7	Allocation of SIME HOME channels	0 = Not assigned 1 = Circuit 1 2 = Three-zone circuit	=	=	1
8	Fan rpm Step ignition	0,0 ... 81	rpmx100	0,1 from 0,1 to 19,9 1 from 20 to 81	0,0
9	Long chimneys	0 ... 20	%	1	0
10	Remote control option setting	1 = SIME HOME 2 = CR 53 3 = RVS 43.143 4 = RVS 46.530 5 = RVS 61.843	=	=	1
11	Correction values external sensor	-5 ... +5	°C	1	0
12	Backlighting duration	-- = Always 0 = Never 1 ... 199	sec. x 10	1	3
13	Modulating pump speed	-- = None Au = Automatic mod. 30...100 = % Settable modulation	%	10	Au
14	Setting second input TA	-- = Contact TA 5...160 = Input 0...10VDC	--	--	--
15	Cascade address	-- = Not enabled 0 = Master 1...7 = Slaves	--	1	--
16	ModBus address	-- = Not enabled 1...31 = Slaves	--	1	--
17	ModBus communication configuration	1 ... 30	--	1	25
19	Type circuit	0 = Two zones 1 = Three zones	--	--	0
D.H.W. - HEATING					
PAR	DESCRIPTION	RANGE	UNIT OF MEASUREMENT	INC/DEC UNIT	DEFAULT SETTING
20	Minimum heating temperature Zone 1	PAR 64 OEM ... PAR 21	°C	1	20
21	Maximum heating temperature Zone 1	PAR 20 ... PAR 65 OEM	°C	1	80
22	Heating curve slope Zone 1	3 ... 40	--	1	20
23	Minimum heating temperature Zone 2	PAR 64 OEM ... PAR 24	°C	1	20
24	Maximum heating temperature Zone 2	PAR 23 ... PAR 65 OEM	°C	1	80
25	Heating curve slope Zone 2	3 ... 40	--	1	20
26	Minimum heating temperature Zone 3	PAR 64 OEM ... PAR 27	°C	1	20
27	Maximum heating temperature Zone 3	PAR 26 ... PAR 65 OEM	°C	1	80
28	Heating curve slope Zone 3	3 ... 40	--	1	20
29	At heating circuit	10 ... 40	°C	1	20
30	Post-circulation heating time	0 ... 199	Sec.	10	30
31	Maximum heating capacity	30 ... 100	%	1	100
32	Zone 1 pump activation delay	0 ... 199	10 sec.	1	1
33	Start-up delay	0 ... 10	Min.	1	3
34	Additional source activation threshold	--, -10 ... 40	°C	1	" - - "
35	Boiler antifreeze	0 ... +20	°C	1	3
36	External sensor antifreeze	-5 ... +5	°C	1	-2
37	Band saturation flowmeter modulation	-- = Disabled 0 ... 100	%	1	100
38	D.H.W. post-circulation time	0 ... 199	Sec.	1	0
39	Anti-legionella (only D.H.W cylinder)	0 = Disabled 1 = Enabled	--	--	0

BOILER	PAR 2
Instantaneous with diverter valve and flowmeter	1
Instantaneous with diverter valve, flowmeter and solar system	2
Remote control cylinder with diverter valve and cylinder sensor T version (LOW INERTIA)	3
On board DHW cylinder, diverter valve and DHW sensor (LOW INERTIA)	4
Remote DHW cylinder with diverter valve and tank thermostat or heating only T/R version (LOW INERTIA)	5
Remote DHW cylinder with double pump and cylinder sensor T/R version (LOW INERTIA)	6
Remote DHW cylinder with double pump and tank thermostat T/R version (LOW INERTIA)	8
Only heating with antifreeze sensor (LOW INERTIA)	9

**NOTE:** the inside of the upper door of the boiler panel has a label with the values that have to be set for PAR 1 and PAR 2 (fig. 19).

### 3.3.2 Warning

If the boiler is functioning but not operating optimally, and not showing any error, press the button until info 70 and the warning code associated to the ongoing event are displayed. Once optimal operation is restored, info 70 will display: "--". Below is the table of warning codes:

CODE	DESCRIPTION
E0ΔE1	E2E3E4E5E6E7E8E9

PARAMETERS INSTALLER					
<b>EXPANSION CARD</b>					
PAR DESCRIPTION	RANGE	UNIT OF MEASUREMENT	INC/DEC UNIT	DEFAULT SETTING	
40	Number of expansion boards	0 ... 3	=	1	0
41	Mix valve stroke time	0 ... 199	10 sec.	1	12
42	Priority of D.H.W. over mixed zone	0 = Paralle 1 = Absolute	=	=	1
43	Floor screed drying( see 4.5.2)	0 = No activated 1 = Curve A 2 = Curve B 3 = Curve A+B	=	=	0
44	Type of solar system	1 ... 8	=	1	1
45	Δt solar collector pump 1	PAR 74 OEM - 1... 50	°C	1	8
46	Solar integration delay	"--", 0 ... 199	Min.	1	0
47	Tmin solar collector	"--", -30 ... 0	°C	1	- 10
48	Tmax solar collector	"--", 80 ... 199	°C	1	120
<b>PARAMETERS RESTORATION</b>					
PAR DESCRIPTION	RANGE	UNIT OF MEASUREMENT	INC/DEC UNIT	DEFAULT SETTING	
49 *	Reset default parameters (par 01 - par 02 = "--")	--, 1	=	=	=
* Should the boiler not be functioning correctly, the original default values can be reset by setting PAR 49 = 1 and the PAR 1 then correctly setting PAR 2 as specified at point 3.3.1.					

## CASCADE CONNECTION PARAMETERS

When the appliance is installed in sequence/cascade (modular system with several generators) it is necessary to set on all the boilers the following INST PAR parameters:

**PAR 15 = 0 for the first boiler (MASTER)  
1 ... 7 for the other boilers (SLAVE)  
(Avoid assigning the same number to SLAVE boilers)**

**Set the following INST parameter if polypropylene smoke collectors with a clapet valve are used in sequence/cascade installations:**

**PAR 1 = 8 (for NATURAL GAS boilers)  
16 (for PROPANE boilers)**

**In addition, when the number of boilers in cascade is more than two, configure the parameters OEM A1 of the MASTER boiler.**

**See 2.2.2 Item CASCADE WITH MORE THAN TWO BOILERS.**

**Set the parameter:  
PAR A1 = Number of cascade generators (3 ... 8)**

### 3.4 EXTERNAL SENSOR (fig. 13)

If there is an external sensor, the heating settings SET can be taken from the climatic curves according to the external temperature and, in any case, limited to with the range values described in point 3.3 (parameters PAR 22 for zone 1, PAR 25 for zone 2 and PAR 28 for zone 3). The climatic curve to be set can be selected from a value of 3 and 40 (at step 1). Increasing the steepness of the curves of fig. 13 will increase the output temperature as the external temperature decreases.

### 3.5 CARD FUNCTIONING

The electronic card has the following functions:

- Antifreeze protection of the heating and sanitary water circuits (ICE).
  - Ignition and flame detection system.
  - Control panel setting for the power and the gas for boiler functioning.
  - Anti-jamming for the pump which is fed for a few seconds after 24 hours of inactivity.
  - Antifreeze protection for boilers with cylinder.
  - Chimney sweep function which can be activated from the control panel.
  - Temperature which can be shifted with the external sensor connected. It can be set from the control panel and is active on the heating systems of both circuit 1 and circuit 2 and 3.
  - Management of 3 independent heating circuit systems.
  - Automatic regulation of the ignition power and maximum heating. Adjustments are managed automatically by the electronic card to guarantee maximum flexibility in use of the system.
  - Interface with the following electronic systems: remote control SIME HOME code 8092280/81, thermal regulator RVS, connected to a management card of a mixed zone MIXED ZONE code 8092234, card solar INSOL code 8092235 and to board RS-485 for managing up to 8 boilers in cascade or implement a communication type Modbus (slave RTU-RS485, Reference Guide PI-MBUS-300 Rev. J) code 8092243.
- NOTE: If using RVS 43 set parameter 10 to 3 (PAR 10 = 3).**

### 3.6 TEMPERATURE DETECTION SENSOR

Table 4 shows the resistance values of the heating, and exhaust fumes thermistors.

If the heating flow sensor (SM), hea-

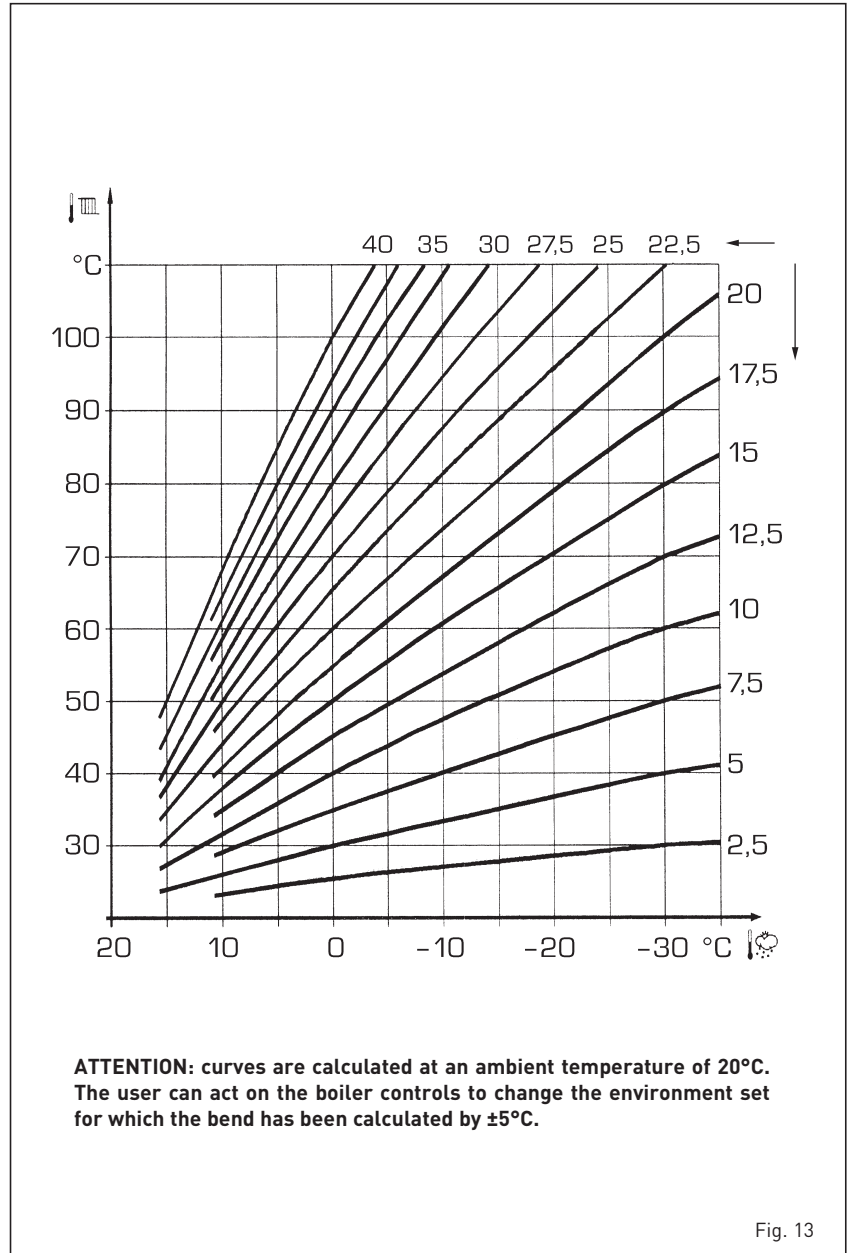

Fig. 13

ting return sensor (SR) or the exhaust fumes sensor (SF) is faulty or open circuit, the boiler will not function.

TABLE 4 (SM - SR - SF sensors)

Temperature (°C)	Resistance (Ω)
20	12.090
30	8.313
40	5.828
50	4.161
60	3.021
70	2.229
80	1.669

### 3.7 ELECTRONIC IGNITION

Ignition and flame detection is controlled by a electrodes on the burner which guarantees reaction in the case of accidental extinction or lack of gas within one second.

#### 3.7.1 Functioning cycle

Burner ignition occurs within max. 10 seconds after the opening of the gas valve. If after three attempts to light, the ignition is not detected, the boiler will lockout. this can be due to:

- **Lack of gas**  
The ignition electrode will discharge for max. 10 seconds. If the burner does not ignite, the error ALL 06 is signalled.  
This can happen the first time the boiler is switched on after a long period of inactivity due to the presence of air in the gas pipes  
It can be caused by a closed gas tap or by a broken valve coil (the interruption does not allow for opening).
- **No Ionisation.**  
The boiler will make three attempts

to light. if after the third attempt the flame has not been recognised, the boiler will lockout ALL06. This may be due to worn or distorted ionisation electrode.

In the case of a sudden lack of voltage, the burner will immediately switch off.

When voltage returns, the boiler will automatically start up again.

### 3.8 HEAD AVAILABLE TO SYSTEM (fig. 14)

Residual head for the heating system is

shown as a function of rate of flow in the graph in fig. 14.

If fitted, the speed of the modulating pump system is set as default (installation parameter **PAR 13 = Au**).

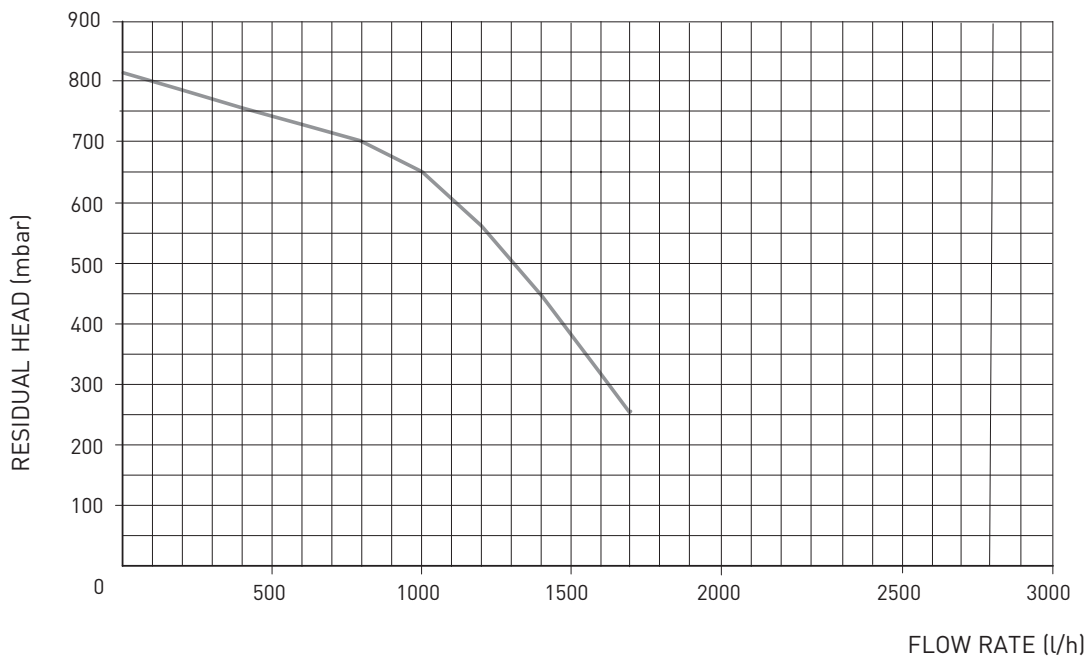

Flow rate (l/h)	RESIDUAL HEAD (mbar)
0	820
200	779
400	756
600	731
800	696
1000	650
1200	564
1400	447
1600	322
1700	260

Fig. 14

3.9 "MURELLE HE 50 R ErP" WITH KIT COMPENSATOR CODE 8101586 AND DHW CYLINDER (fig. 15)

KEY

- 1 Gas valve
- 2 Condensation drain trap
- 3 DHW Cylinder pump (not supplied)
- 4 Fan
- 5 Heating flow sensor (SM)
- 6 Safety thermostat 100°C
- 7 Exhaust sensor (SF)
- 8 Primary exchanger
- 10 Heating return sensor (SR)
- 11 Water pressure transducer
- 12 Auto air vent
- 13 Pump high efficiency
- 14 Manual drain vent
- 15 Gas cock (supplied in kit)
- 16 Non return valve
- 17 Safety valve 3.5 bar
- 18 Non return valve (not supplied)
- 19 Hydraulic compensator (supplied in the kit)
- 20 Drain tap (supplied in kit)
- 21 Expansion vessel 8 liter (supplied in the kit)
- 22 Air relief valve (supplied in kit)
- 23 Oblique filter (not supplied)
- 29 DHW cylinder (not supplied)
- 32 Isolation valves (two supplied in the kit)

CONNECTIONS

- M Heating flow
- R Heating return
- G Gas
- S3 Condensation drain
- C System filling
- M2 D.H.W. tank flow
- R3 D.H.W. tank return

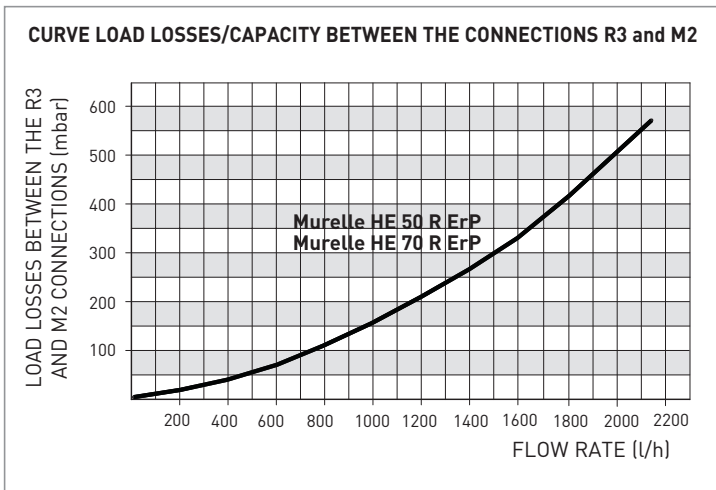
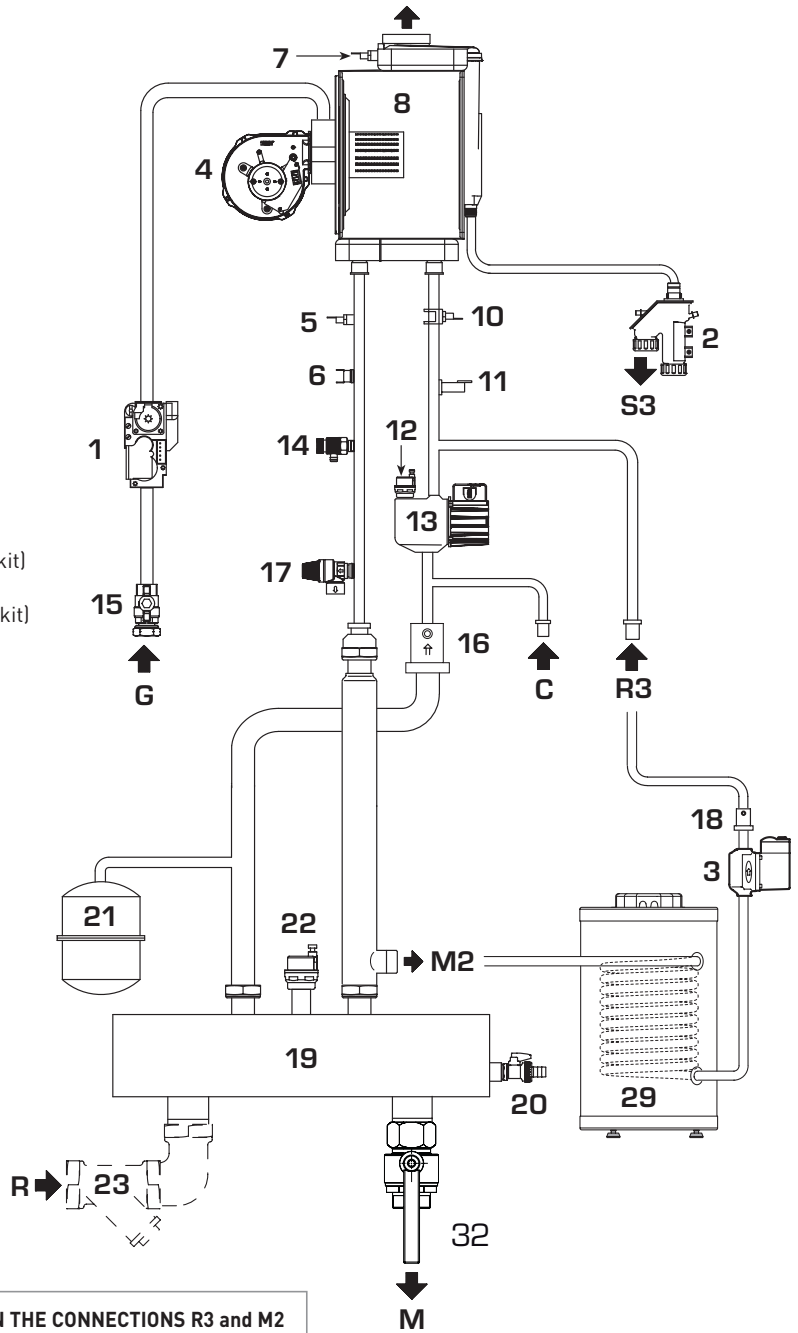

The DHW cylinder pump (3) should be sized according to the losses of the domestic circuit (cylinder and pipework) and ensure the minimum flow rate (2,200 l/h).

Fig. 15

## 4 COMMISSIONING, USE and MAINTENANCE

### COMMISSIONING INSTRUCTIONS

A Commissioning checklist is included in this manual and must be completed by the engineer at the time of commissioning.

#### General

Please note: the combustion for this appliance has been checked, adjusted and preset at the factory for operation on the gas type defined on the appliance data plate. However, it is advisable to check for correct combustion having first checked the following.

- That the boiler has been installed in accordance with these instructions
- The integrity of the flue system and the flue seals
- That PAR 9 has been set according to the calculated flue head losses (single boilers)
- That PAR 1 is set correctly for boilers connected to cascade flues
- The integrity of the boiler combustion circuit

Proceed to put the boiler into operation as follows:

#### 1. Check the operational (working) gas inlet pressure.

Set up the boiler(s) to operate at maximum rate as described in 4.5.1

(chimney sweep)

With the boiler operating in the maximum rate condition check that the operational (working) gas pressure at the inlet gas pressure test point (see fig 16 item 1) complies with the requirements of table 1.3.

Ensure that this inlet pressure can be obtained with all other gas appliances in the property working.

#### 2. Competence to carry out the check of combustion performance

- The person carrying out a combustion measurement should have been assessed as competent in the use of a flue gas analyser and the interpretation of the results.
- The flue gas analyser used should be one meeting the requirements of BS7927 or BS-EN50379-3 and be calibrated in accordance with the analyser manufacturers requirements, and
- Competence can be demonstrated by satisfactory completion of the CPA1 ACS assessment, which covers the use of electronic portable gas analysers in accordance with BS 7967, parts 1 to 4.

#### 3. Combustion check

Connect the flue gas analyser to the flue gas sampling point as shown in the diagram (fig. 15/a).

Procedure for checking the combustion.

Operate the boilers in "Chimney Sweep" mode as described in section 4.5.1 and record the measurements from the flue gas analyser on both minimum and maximum output. Compare the results to the following:

CO less than 200ppm

CO<sub>2</sub> between 8.9% and 9.7% natural gas, and 9.9% and 10.5% LPG Ratio less than 0.004

If the combustion reading is greater than the acceptable value AND the integrity of the complete flue system, combustion circuit seals have been verified, AND the gas inlet pressure has been verified, AND the boiler parameter settings are correct, proceed as shown in 4.2.2. Any adjustments should be done in small steps and adjustments of no more than 1/8th of a turn should be made, waiting at least 1 minute between adjustments to allow the settings to stabilise. Using the CO<sub>2</sub> reading, adjustments should be made to the "OFF-SET" screw (6 fig 16) if it is incorrect at the minimum output, or to the "SHUTTER" (5 fig 16) if it is incorrect at the maximum output.

If an acceptable setting level cannot be achieved, re-confirm that the integrity of the flue system, combustion circuit and working gas supply pressure. If required contact Sime Ltd for further assistance.

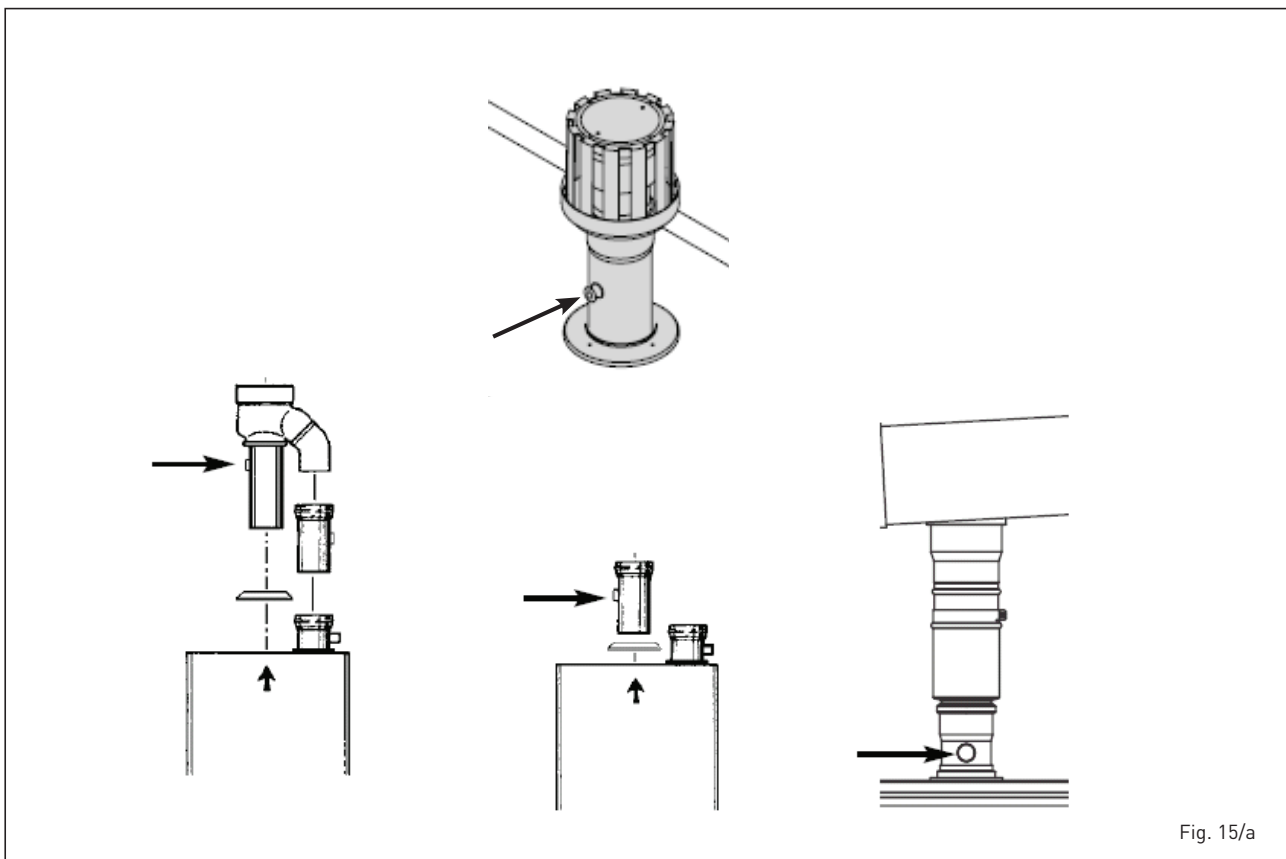

Fig. 15/a

#### 4.1 GAS VALVE (fig. 16)

The boiler is supplied as standard with the SIT 848 SIGMA gas valve (fig. 16).

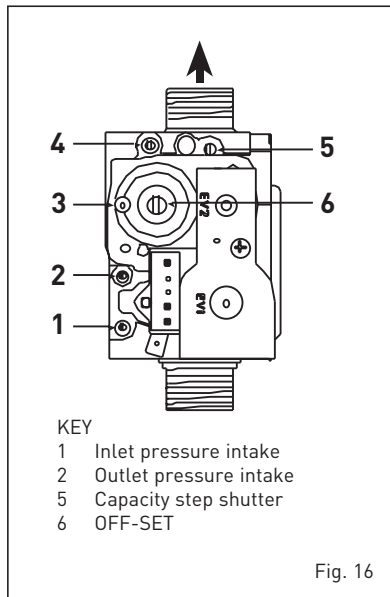

Fig. 16

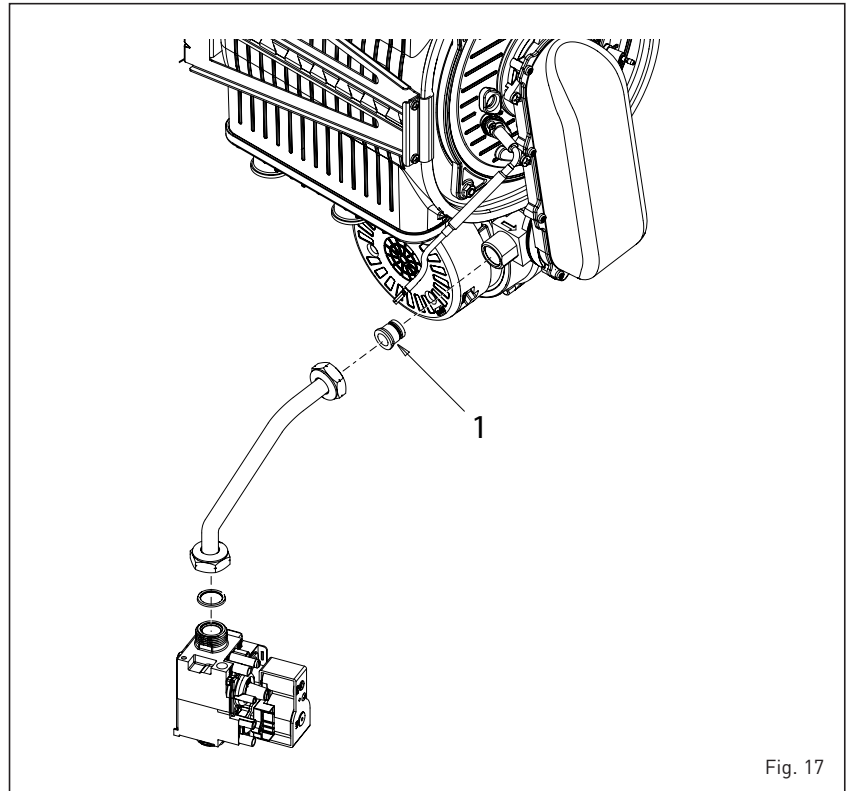

Fig. 17

#### 4.2 GAS CONVERSION (fig. 17)

**This operation must be performed by authorised personnel using original Sime components.**

To convert from natural gas to LPG or vice versa, perform the following operations

- Close the gas cock.
- Replace the nozzle with seal gasket OR (1) with the one supplied in the transformation kit.
- On completion of the conversion test all gas connections using suitable leak detection fluid. Do not use naked flames.
- Apply the new data plate information, showing the correct gas used.
- Re configure PAR1, as shown in 4.2.1 and check the combustion performance as described in 4.2.2.

##### 4.2.1 New fuel configuration

For access to the installer's parameters, press simultaneously keys and for 5 seconds (3 fig. 12).

The parameters will scroll up and down with the keys and .

The display pane will show the values of the parameter PAR 1.

If the boiler is a methane (G20) model, SET 5 will be displayed:



To change the fuel to propane (G31), it is necessary to set SET 13, by pressing the key .

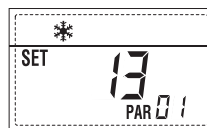

The standard display will automatically return after 10 seconds.

The table below shows the SET settings to enter when the type of gas fuel is changed.

GAS	MODEL	PAR 1
METHANE (G20)	Single (50 R ErP)	5
	Sequence/cascade	6
PROPANE (G31)	Single (50 R ErP)	13
	Sequence/cascade	14

##### 4.2.2 Calibrating the gas valve pressures

This can only be done using a flue gas

analyser. If the combustion reading is greater than the acceptable value AND the integrity of the complete flue system and combustion seals have been verified, and the inlet gas pressure has been verified, then adjustments to the gas valve can be made as described below. Make only small adjustments (1/8 turn max) and allow time for the combustion analysis to be made before making further adjustments.

##### Sequence of operations:

- 1) Press and hold the button down for a few seconds .
- 2) Press the button for a few seconds .
- 3) Identify the CO<sub>2</sub> values at max. power by adjusting the shutter (5 fig. 16):

MAX power	
CO <sub>2</sub> (Methane)	CO <sub>2</sub> (Propane)
9,2 ±0,2	10,3 ±0,3

- 4) Press the button for a few seconds .
- 5) Identify the CO<sub>2</sub> values at min. power by adjusting the OFF-SET regulation screw (6 fig. 16):

MIN power	
CO <sub>2</sub> (Methane)	CO <sub>2</sub> (Propane)
9,5 ±0,2	10,0 ±0,3



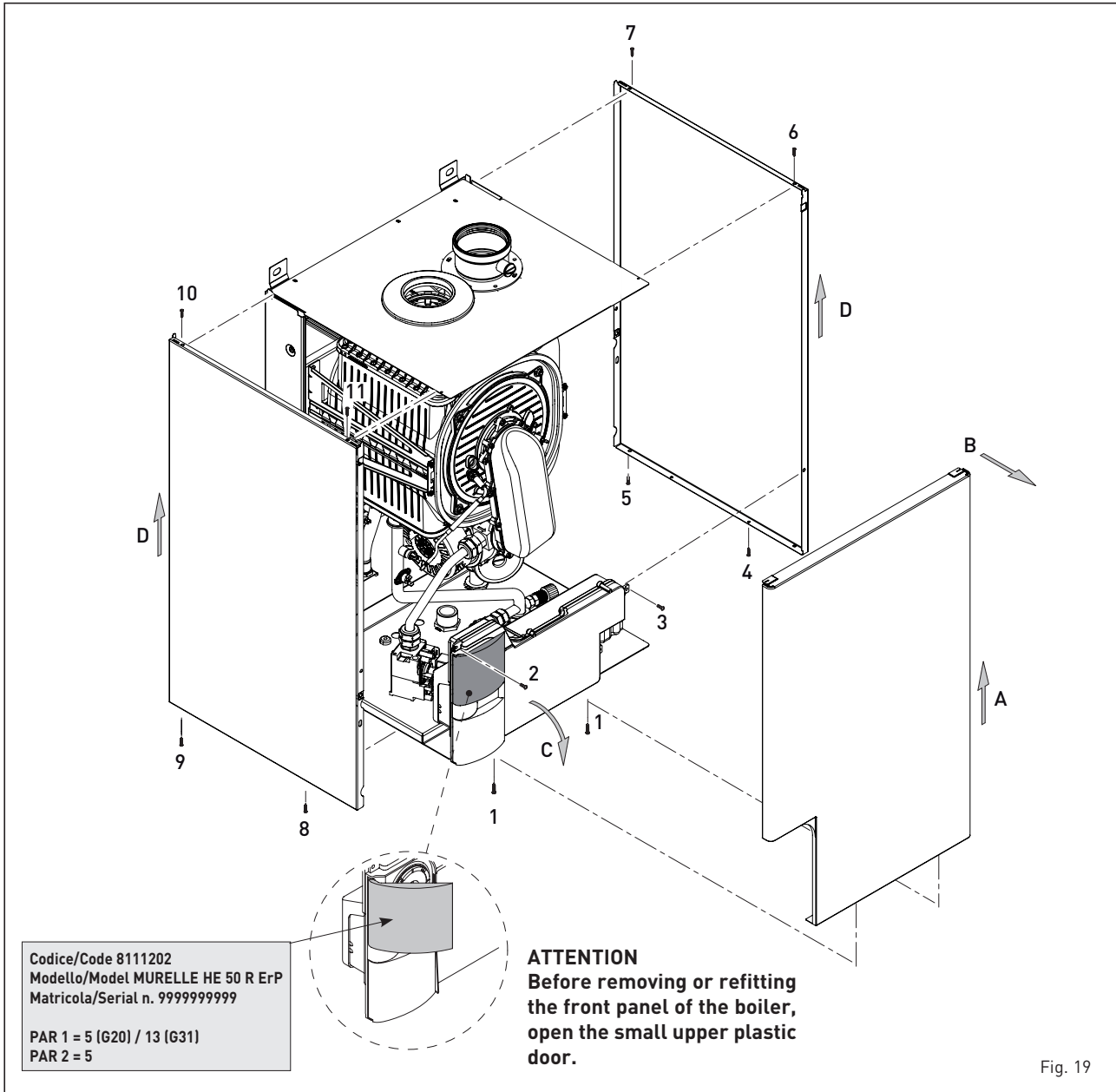

Fig. 19

- 6) Press the buttons several times to check the pressures and change them if required.
- 7) Press the button once more to quit the function.

the boiler, it is also possible to completely remove the shell, as shown in figure 19.  
 Turn the control panel to move it forward and be able to access the internal components of the boiler.

ring water into the combustion chamber while the burner is removed.  
 should the boiler not be used for long periods of time, it is important that the condensate trap is checked and filled if required. It can be filled via the filling vent, see fig 20.

#### 4.3 CO / CO<sub>2</sub> RATIO

		CO ppm	
		100	400
CO <sub>2</sub> %	NG 9%	0,0011	0,0044
	LPG 10%	0,0010	0,0040

#### 4.4 DISASSEMBLING THE SHELL (fig. 19)

To simplify maintenance operations on

#### 4.5 MAINTENANCE (fig. 20)

To ensure correct operation and efficiency it is important that the appliance is serviced at regular intervals, at least once a year (this may also be a condition of the warranty). servicing must only be done by suitably qualified technicians. It is recommended that the service should include removal and inspection of the burner and its insulation. On completion a combustion analysis must be done. During the routine service the condensate drain can be checked by carefully pou-

**ATTENTION: Before performing any work on the boiler, make sure that the**

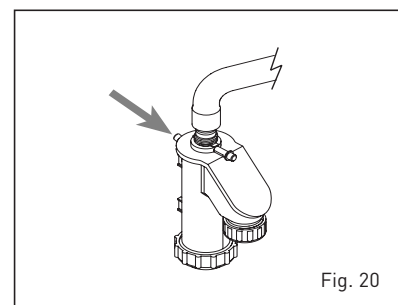

Fig. 20

same and its components have cooled in order to prevent the risk of burns due to high temperatures.

#### 4.5.1 Chimney sweep function (fig. 21)

To check boiler combustion, press the installer's key for a few seconds. The chimney sweep function will switch on and will continue for 15 minutes. The boiler will start working in heating mode at maximum power, with cut off at 80°C and re-ignition at 70°C **(ATTENTION! Ensure adequate circulation to the heating system is available before activating chimney sweep)**.

If the key and are pressed during the 15 minutes of the chimney sweep function, the boiler will be brought respectively to maximum and minimum power.

**The chimney sweep function will automatically switch off after 15 minutes or when the key is pressed again.**

#### 4.5.2 Operation floor drying (fig. 22)

The operation floor drying keeps the floor at a pre-established temperature profile and it is **activated only for those systems combined with the mixed zone card MIXED ZONE code 8092234**.

The temperature profiles can be selected by means of the installer parameter PAR 43:

- 0 = Not activated function
- 1 = Curve setting A
- 2 = Curve setting B
- 3 = Curve setting A + B

The turning off of the function happens clicking on the button OFF (return of PAR 43 to the value 0) or automatically at the end of the function.

The set of the mixed zone follows the development of the selected curve and reaches a maximum of 55°C.

During the function all the other heating demands are ignored (heating, sanitary, antifreeze and chimney sweep).

During the functioning the display shows the remaining days for the completion of the function (example mains digits -15 = 15 days lack to the end of the function). The diagram fig. 22 reports the development of the curve.

#### ATTENTION:

- **Observe the relevant standards and regulations of the floor manufacturer!**
- **Proper functioning is ensured only when the plant is correctly installed (hydraulic system, electrical installation, settings)! If not observed, the floor might get damaged!**

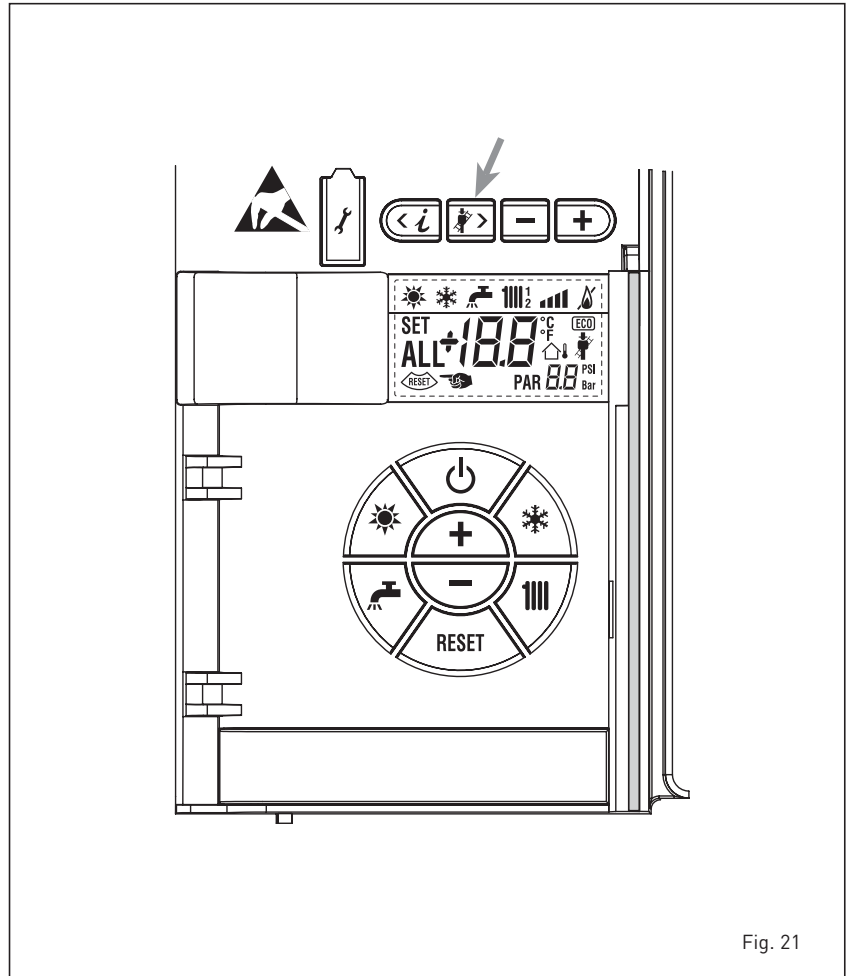
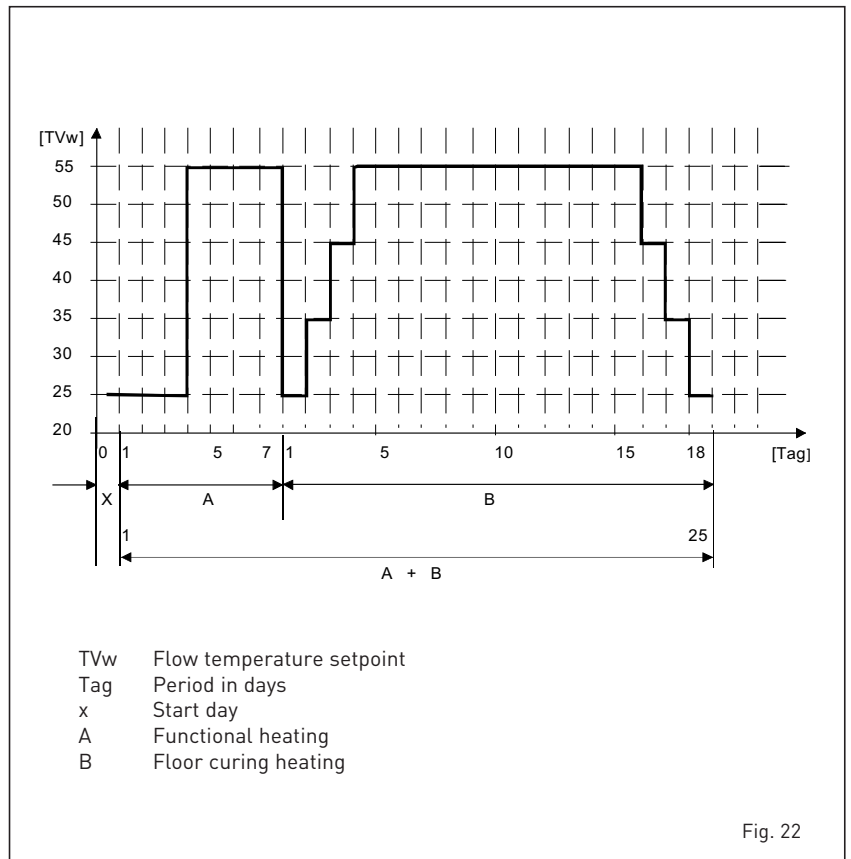

Fig. 21



- TVw Flow temperature setpoint
- Tag Period in days
- x Start day
- A Functional heating
- B Floor curing heating

Fig. 22

#### 4.5.3 Pump high efficiency diagnose and remedy (fig. 22/a)

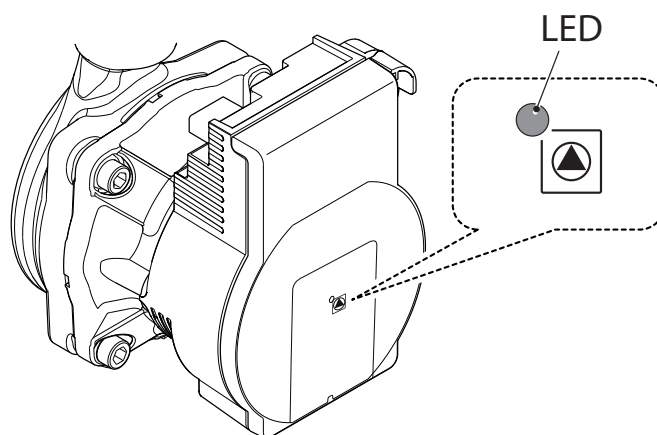

On the pump there is a signal LED which indicates:

Colour LED	Status	Diagnostics
LED Off		Electrical power failure
Green	Steady	Normal operation
Red/Green	Flashing	Fault in progress
Red	Flashing	Fault in progress
Red	Steady	Permanent Lockout

Colour of LED	Possible fault	Cause	Possible solution
Flashing Red-Green	Turbine operation	The hydraulic system of the pump is powered, but the pump has no mains voltage	- Check the mains voltage
	Idle operation	Air in the pump	- Check that there are no leaks in the system
	Overload	The motor runs with difficulty. The number of revolutions is lower compared to normal operation	- Check the mains voltage - Check the system flow rate/pressure - Check the characteristics of the water in the system; remove debris from the system
Flashing red	Under/overvoltage	Supply voltage too low/high	- Check the mains voltage
	Excessive temperature	Excessive temperature inside the pump	- Check the water temperature level in relation to that of the ambient temperature - Check the mains voltage - Check the environmental operating conditions
	Short circuit	Motor current too high	- Check the mains voltage
Steady red	"Permanent lockout" stop	Rotor blocked	- REPLACE THE PUMP
		Circuit board and/or motor failure	- REPLACE THE PUMP
LED Off	Stopped	Electrical power failure	- Check the connection to the power supply
		Faulty LED	- Check to see if the pump can work
		Faulty circuit board	- REPLACE THE PUMP

Fig. 22/a

#### 4.6 FUNCTIONING ERRORS

When there is a functioning error, an alarm appears on the display **and the blue luminous bar may becomes red.**

Descriptions of the errors with relative alarms and solutions are given below:

– **LOW WATER PRESSURE ERRORS ALARM 02 (fig. 23/a)**

If the pressure detected by the transducer is lower than 0.5 bar, the boiler stops and the display shows the alarm ALL 02. Using the external filling device, fill the system until the pressure indicated by the transducer is between 1 and 1.5 bars.

**If the refilling procedure has to be repeated several times, it is advisable to check that the seal of the heating circuit is intact (check that there are no leaks).**

– **HIGH WATER PRESSURE ERRORS ALARM 03 (fig. 23/b)**

If the pressure detected by the transducer is more than 2.8 bar, the boiler stops and the display shows error ALL 03.

– **HEATING FLOW SENSOR ERRORS ALARM 05 (fig. 23/d)**

If the heating flow sensor (SM) is open or short circuited, the boiler will not function and the display will show the alarm ALL 05.

– **LOCKOUT ALARM 06 (fig. 23/e)**

If the flame control has not detected the presence of the flame after a complete ignition sequence, or for any other reason the card cannot “see” the flame, the boiler will stop and the display will show the alarm ALL 06.

Press the key  of the controls (2) to start up the boiler again.

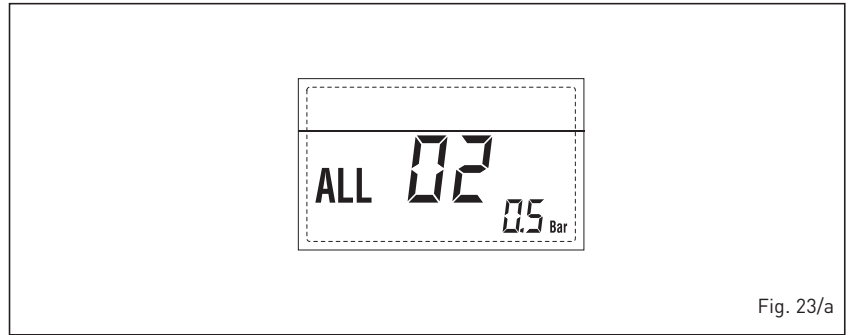

Fig. 23/a

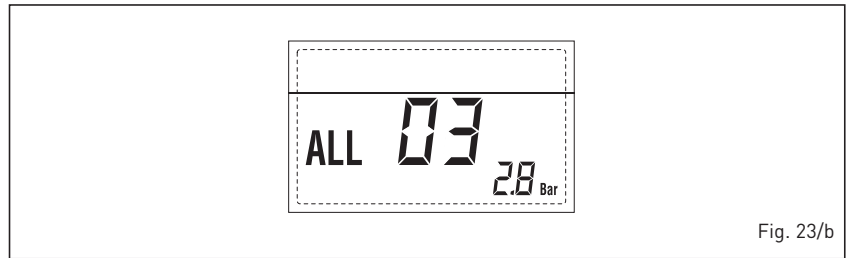

Fig. 23/b

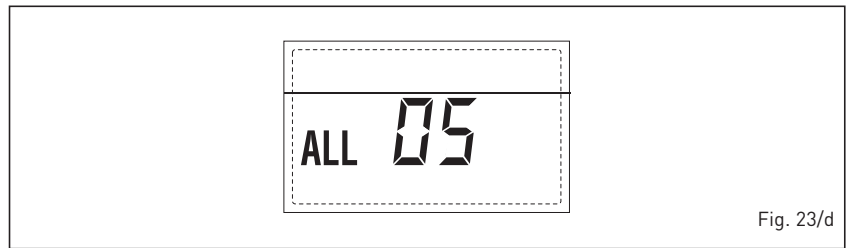

Fig. 23/d

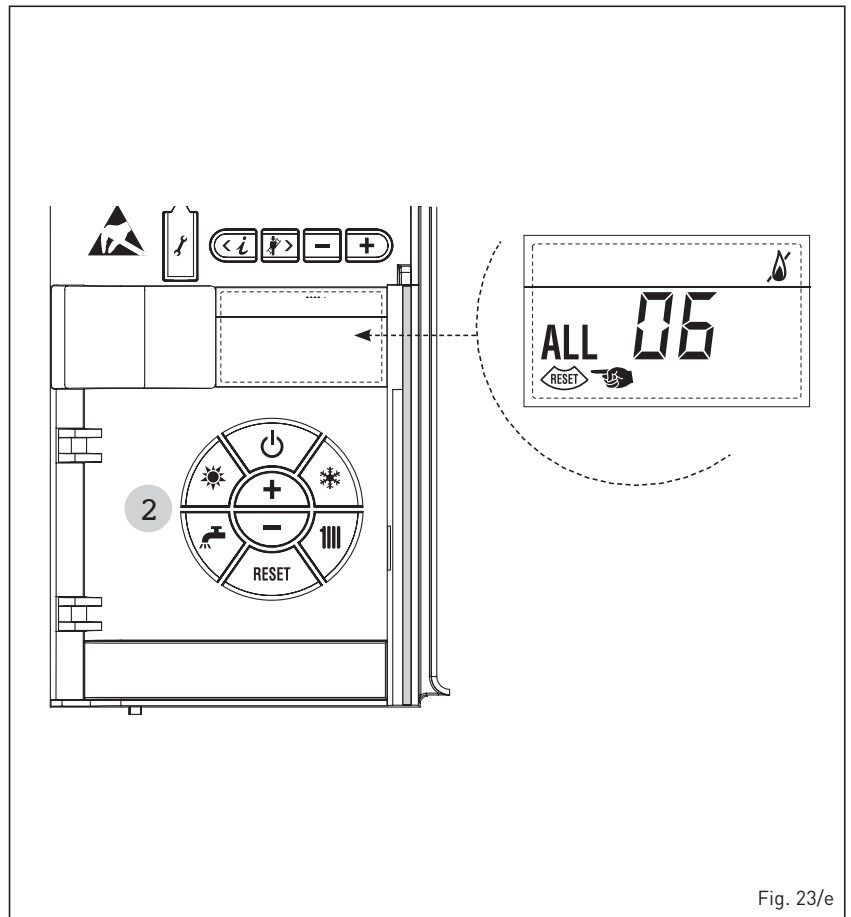

Fig. 23/e

**- SAFETY/LIMIT THERMOSTAT ERROR ALARM 07 (fig. 23/f)**

If the connection with the safety thermostat/limit thermostat is interrupted, the boiler will stop; the flame control will remain waiting to be switched off for one minute, keeping the system pump on for that period. If, the thermostat connection is restored within the minute, the boiler will start up working normally again; otherwise it will stop and the display will show the alarm ALL 07.

Press the key  of the controls [2] to start up the boiler again.

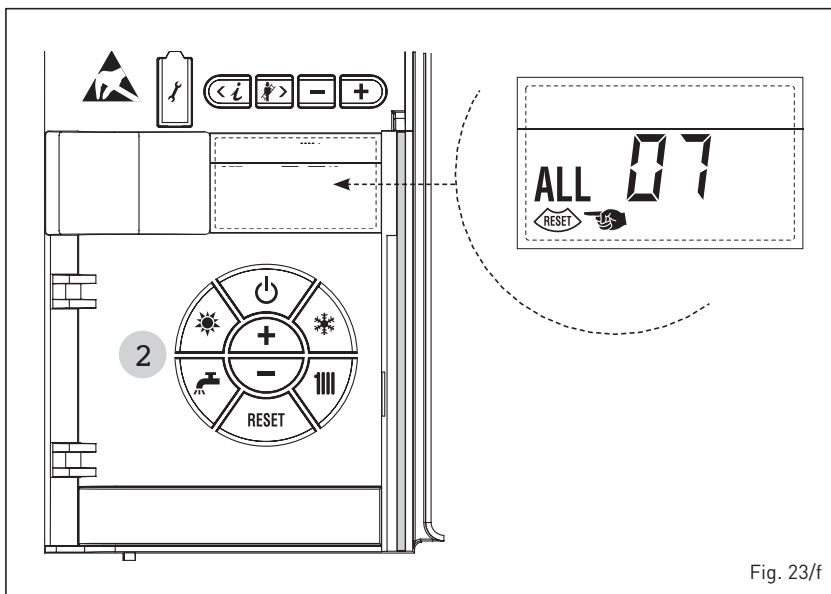

Fig. 23/f

**- FLAME DETECTION ERROR ALARM 08 (fig. 23/g)**

If the flame control section recognises the presence of flames also in phases when they should not be present, it means there is a breakdown in the flame detection circuit; the boiler will stop and the display will show error ALL 08.

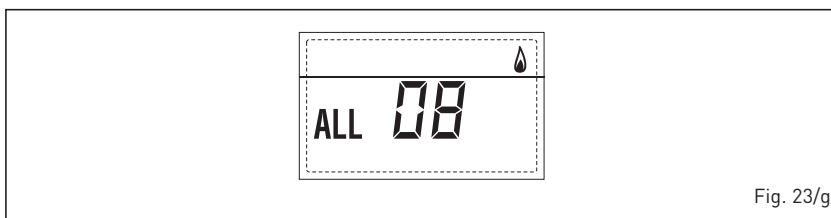

Fig. 23/g

**- WATER CIRCULATION ERRORS ALARM 09 (fig. 23/h)**

1, Water circulation has not been detected in the primary(boiler) circuit. If this error is detected the boiler will make two further attempts. If circulation is not detected it will stop and display ALL09.

**Note, circulation is detected by a small rise in system pressure at the boiler transducer when the pump is energised. In large systems this may not be detected, and can be disabled by alteration of PAR 4.**

2, The flow temperature sensor has detected a temperature rise in excess of 5 degrees per second.

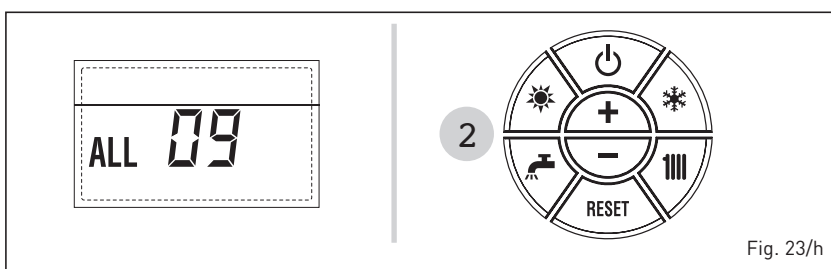

Fig. 23/h

**- AUXILIARY SENSOR ERRORS ALARM 10 (fig. 23/i)**

SB sensor (if fitted), shorted or open circuit. Confirm correct setting of PAR2.

On BOX version shorted or open circuit of SA sensor

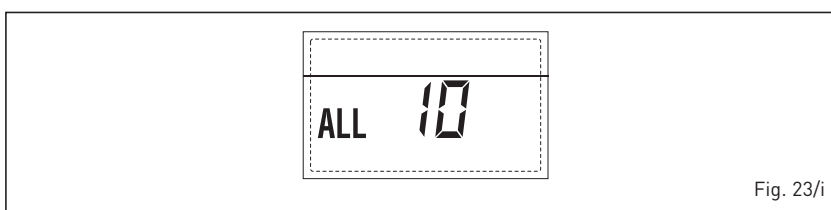

Fig. 23/i

**- ACTIVATION OF THE EXHAUST TEMPERATURE SENSOR "ALL 13" (fig. 23/j)**

The activation of this probe causes the boiler to stop and error message ALL 13 to display.

Press the key  of the controls [2] to start up the boiler again.

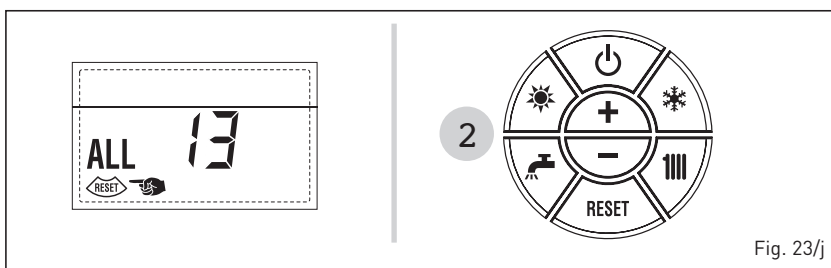

Fig. 23/j

**- EXHAUST TEMPERATURE SENSOR ERROR "ALL 14"(fig. 23/k)**

If the exhaust fumes probes is open or short-circuited, the boiler stops and error message ALL 14 displays.



Fig. 23/k

- **FAN ERROR "ALL 15" (fig. 23/m)**

The fan speed does not fall within the rated speed range.

If the error conditions persists for two minutes, the boiler activates a forced stop for thirty minutes.

A new start attempt is repeated after the expiry of this interval of time.

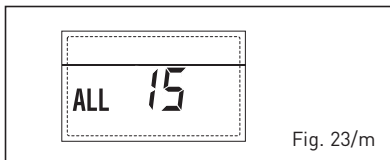



Fig. 23/m

- **EXTERNAL PROBE ERROR "FLASHING" (fig. 23/p)**

When fitted if the external probe (SE) is short-circuited, the display the symbol flashes .

During such anomaly the boiler continues normal functioning.

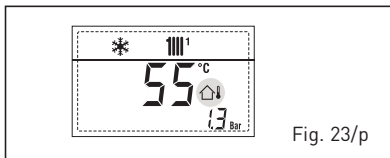

Fig. 23/p

- **SAFETY THERMOSTAT INTERVENTION FIRST MIXED ZONE "ALL 20" (fig. 23/q)**

When the mixed zone board is connected to the boiler, a safety thermostat intervention switches on the mixed zone pump, the mixed zone valve closes and the display indicates error ALL 20.

During this error the boiler continues to function normally.

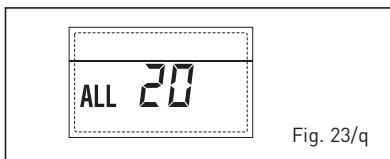

Fig. 23/q

- **DELIVERY PROBE BREAKDOWN ERROR FIRST MIXED ZONE "ALL 21" (fig. 23/r)**

When a mixed zone board is connected to the boiler, if the delivery probe becomes open or short circuit the display will indicate ALL21.

During this error, the boiler continues to function normally.

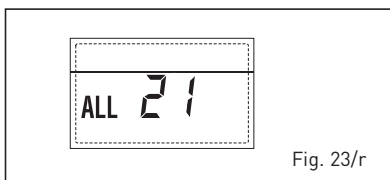

Fig. 23/r

- **SAFETY THERMOSTAT INTERVENTION SECOND MIXED ZONE "ALL 22" (fig. 23/s)**

When a mixed zone board is connected to the boiler, an intervention of the safety thermostat switches on the mixed zone pump, the mixed zone valve closes and the display indicates ALL 22. During this anomaly the boiler continues to function normally.

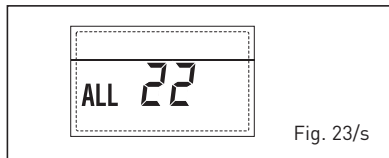

Fig. 23/s

- **DELIVERY PROBE BREAKDOWN ERROR SECOND MIXED ZONE "ALL 23" (fig. 23/t)**

When a mixed zone board is connected to the boiler, if the delivery probe is open or short circuited, the display will indicate ALL 23 appears. During this anomaly the boiler continues to function normally.

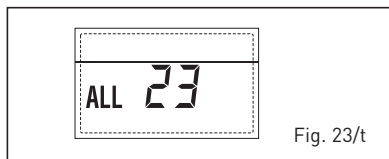

Fig. 23/t

- **SOLAR COLLECTOR SENSOR ERROR (S1) "ALL 24" (fig. 23/18)**

When the solar probe is open or short circuited, on the display the anomaly ALL 24 appears. During this anomaly the boiler continues to function normally but loses the solar function that is no longer available.

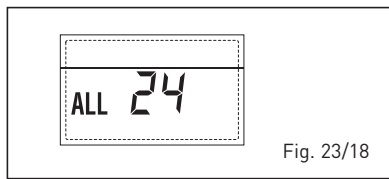

Fig. 23/18

- **SOLAR PROBE ERROR STORAGE TANK (S2) "ALL 25" (fig. 23/19)**

When the solar probe is open or short circuited, on the display the anomaly ALL 25 appears. During this anomaly the boiler continues to function normally but loses the solar function that is no longer available.

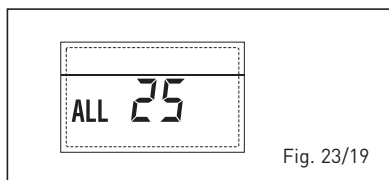

Fig. 23/19

- **AUXILIARY SENSOR ERROR (S3) "ALL 26" (fig. 23/20)**

When the solar probe is open or short circuited, on the display the anomaly ALL 26 appears. During this anomaly the boiler continues to function normally but loses the solar function that is no longer available.

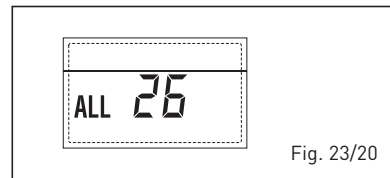

Fig. 23/20

- **ERROR SOLAR APPLICATION COMPATIBILITY "ALL 27" (fig. 23/21)**

When the hydraulic configuration PAR 2 is not consistent with the selection solar application, on the display the anomaly ALL 27 appears. During this anomaly the boiler continues to function normally but for the board is active in the solar anomaly, the function is only available antifreeze collector.

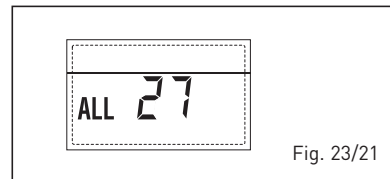

Fig. 23/21

- **COMPATIBILITY INPUT (S3) ERROR ONLY FOR SYSTEM 7 "ALL 28" (fig. 23/22)**

When a probe is connected instead of a clean contact on entry S3 the board on display shows the anomaly ALL 28. During this anomaly the boiler continues to function normally but for the board is active in the solar anomaly, the function is only available antifreeze collector.

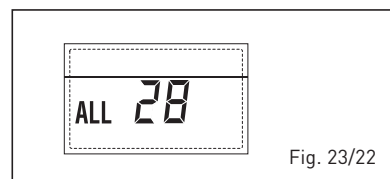

Fig. 23/22

- **ERROR NUMBERS RELATED BOARD "ALL 29" (fig. 23/23)**

When there is no communication with a fitted expansion board, the display will indicate ALL29.

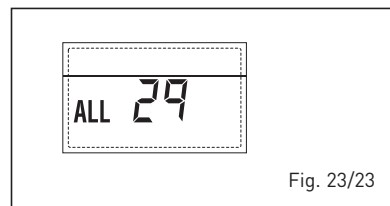
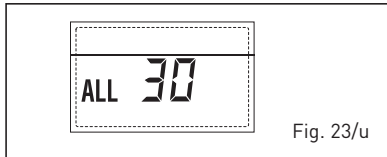

Fig. 23/23

- **HEATING RETURN SENSOR ERROR "ALL 30" (fig. 23/u)**

When the heating return sensor (SR) is open or shorted, ALL 30 will be displayed.

During such anomaly, the boiler will continue to operate normally.



- **RS-485 BOARD COMMUNICATION ERROR IN CASCADE MODE "ALL 34" (fig. 23/j)**

When PAR 15 is different from "--" and there is no communication between the boiler board and the RS-485 board in CASCADE mode, the boiler stops and anomaly ALL 34 is displayed. The boiler restarts when communication is restored or when PAR 15 = "--" is set.

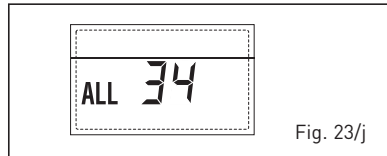

- **CASCADE DELIVERY SENSOR ERRORS "ALL 31" (fig. 23/v)**

In cascade systems, should the delivery probe sensor (SMC) become open or short circuited, the display will show ALL 31.

During such anomaly, the boiler will continue to operate normally.

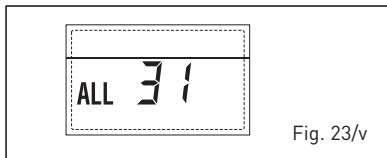

- **RS-485 AND RS-485 COMMUNICATION ERROR "ALL 35" (fig. 23/x)**

When PAR 15 is different from "--" and there is no communication between the two RS-485 boards, the boiler stops and error ALL 35 is displayed. The boiler restarts when communication is restored or when PAR 15 = "--" is set.

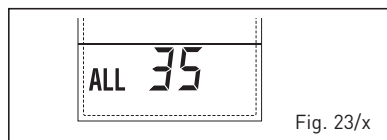

- **THREE-ZONE SYSTEM CONFIGURATION ERROR "ALL 32" (fig. 23/w)**

When the boards connected to the RS-485 are not enough and/or at least one of them it is not mixing zone board, the boiler stops and anomaly ALL 32 is displayed.

The boiler restarts when the boiler three-zone system configuration is activated

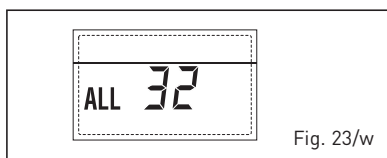

**CAUTION: In the event of sequence/cascade connection, error codes 70 and 71 will appear on the SIME HOME remote control display:**

- **ALARM 70**

When an anomaly affects cascade operation (cascade delivery sensor ALL 31), SIME HOME remote control display will show alarm 70. Verify the anomaly in the cascade.

- **ALARM 71**

When an anomaly occurs in one of the modules and the others keep operating to the extent permitted, the SIME HOME remote control display will show alarm 71. Verify the anomaly in the cascade.

- **RS-485 BOARD COMMUNICATION ERROR IN MODBUS MODE "ALL 33" (fig. 23/k)**

When PAR 16 is different from "--" and there is no communication between the boiler board and the RS-485 board in MODBUS mode for at least four minutes, the boiler stops and anomaly ALL 33 is displayed.

The boiler restarts when communication is restored or when PAR 16 = "--" is set.

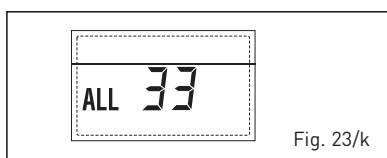

## GAS BOILER SYSTEM COMMISSIONING CHECKLIST

This Commissioning Checklist is to be completed in full by the competent person who commissioned the boiler as a means of demonstrating compliance with the appropriate Building Regulations and then handed to the customer to keep for future reference.

Failure to install and commission according to the manufacturer's instructions and complete this Benchmark Commissioning Checklist will invalidate the warranty. This does not affect the customer's statutory rights.

Customer name:		Telephone number:	
Address:			
Boiler make and model:			
Boiler serial number:			
Commissioned by (PRINT NAME):		Gas Safe register number:	
Company name:		Telephone number:	
Company address:			
		Commissioning date:	
<b>To be completed by the customer on receipt of a Building Regulations Compliance Certificate*</b>			
Building Regulations Notification Number (if applicable):			
<b>CONTROLS</b> (tick the appropriate boxes)			
Time and temperature control to heating	Room thermostat and programmer/timer		Programmable room thermostat
	Load/weather compensation		Optimum start control
Time and temperature control to hot water	Cylinder thermostat and programmer/timer		Combination Boiler
Heating zone valves	Fitted		Not required
Hot water zone valves	Fitted		Not required
Thermostatic radiator valves	Fitted		Not required
Automatic bypass to system	Fitted		Not required
Boiler interlock			Provided
<b>ALL SYSTEMS</b>			
The system has been flushed and cleaned in accordance with BS7593 and boiler manufacturer's instructions			Yes
What system cleaner was used?			
What inhibitor was used?			Quantity litres
Has a primary water system filter been installed?			Yes No
<b>CENTRAL HEATING MODE</b> measure and record:			
Gas rate	m <sup>3</sup> /hr	OR	ft <sup>3</sup> /hr
Burner operating pressure (if applicable)	mbar	OR Gas inlet pressure	mbar
Central heating flow temperature			°C
Central heating return temperature			°C
<b>COMBINATION BOILERS ONLY</b>			
Is the installation in a hard water area (above 200ppm)?			Yes No
If yes, and if required by the manufacturer, has a water scale reducer been fitted?			Yes No
What type of scale reducer has been fitted?			
<b>DOMESTIC HOT WATER MODE</b> Measure and Record:			
Gas rate	m <sup>3</sup> /hr	OR	ft <sup>3</sup> /hr
Burner operating pressure (at maximum rate)	mbar	OR Gas inlet pressure at maximum rate	mbar
Cold water inlet temperature			°C
Hot water has been checked at all outlets			Yes Temperature °C
Water flow rate			l/min
<b>CONDENSING BOILERS ONLY</b>			
The condensate drain has been installed in accordance with the manufacturer's instructions and/or BS5546/BS6798			Yes
<b>ALL INSTALLATIONS</b>			
Record the following:	At max. rate:	CO ppm	AND CO/CO <sub>2</sub> Ratio
	At min. rate: (where possible)	CO ppm	AND CO/CO <sub>2</sub> Ratio
The heating and hot water system complies with the appropriate Building Regulations			Yes
The boiler and associated products have been installed and commissioned in accordance with the manufacturer's instructions			Yes
The operation of the boiler and system controls have been demonstrated to and understood by the customer			Yes
The manufacturer's literature, including Benchmark Checklist and Service Record, has been explained and left with the customer			Yes
Commissioning Engineer's Signature			
Customer's Signature			
(To confirm satisfactory demonstration and receipt of manufacturer's literature)			

\*All installations in England and Wales must be notified to Local Authority Building Control (LABC) either directly or through a Competent Persons Scheme. A Building Regulations Compliance Certificate will then be issued to the customer.

© Heating and Hotwater Industry Council (HHIC)



## SERVICE RECORD

It is recommended that your heating system is serviced regularly and that the appropriate Service Interval Record is completed.

### Service Provider

Before completing the appropriate Service Record below, please ensure you have carried out the service as described in the manufacturer's instructions. Always use the manufacturer's specified spare part when replacing controls.

<b>SERVICE 01</b>					Date:
Engineer name:					
Company name:					
Telephone No:					
Gas safe register No:					
Record:	At max. rate:	CO	ppm	AND	CO <sub>2</sub> %
	At min. rate: (Where Possible)	CO	ppm	AND	CO <sub>2</sub> %
Comments:					
Signature					

<b>SERVICE 02</b>					Date:
Engineer name:					
Company name:					
Telephone No:					
Gas safe register No:					
Record:	At max. rate:	CO	ppm	AND	CO <sub>2</sub> %
	At min. rate: (Where Possible)	CO	ppm	AND	CO <sub>2</sub> %
Comments:					
Signature					

<b>SERVICE 03</b>					Date:
Engineer name:					
Company name:					
Telephone No:					
Gas safe register No:					
Record:	At max. rate:	CO	ppm	AND	CO <sub>2</sub> %
	At min. rate: (Where Possible)	CO	ppm	AND	CO <sub>2</sub> %
Comments:					
Signature					

<b>SERVICE 04</b>					Date:
Engineer name:					
Company name:					
Telephone No:					
Gas safe register No:					
Record:	At max. rate:	CO	ppm	AND	CO <sub>2</sub> %
	At min. rate: (Where Possible)	CO	ppm	AND	CO <sub>2</sub> %
Comments:					
Signature					

<b>SERVICE 05</b>					Date:
Engineer name:					
Company name:					
Telephone No:					
Gas safe register No:					
Record:	At max. rate:	CO	ppm	AND	CO <sub>2</sub> %
	At min. rate: (Where Possible)	CO	ppm	AND	CO <sub>2</sub> %
Comments:					
Signature					

<b>SERVICE 06</b>					Date:
Engineer name:					
Company name:					
Telephone No:					
Gas safe register No:					
Record:	At max. rate:	CO	ppm	AND	CO <sub>2</sub> %
	At min. rate: (Where Possible)	CO	ppm	AND	CO <sub>2</sub> %
Comments:					
Signature					

<b>SERVICE 07</b>					Date:
Engineer name:					
Company name:					
Telephone No:					
Gas safe register No:					
Record:	At max. rate:	CO	ppm	AND	CO <sub>2</sub> %
	At min. rate: (Where Possible)	CO	ppm	AND	CO <sub>2</sub> %
Comments:					
Signature					

<b>SERVICE 08</b>					Date:
Engineer name:					
Company name:					
Telephone No:					
Gas safe register No:					
Record:	At max. rate:	CO	ppm	AND	CO <sub>2</sub> %
	At min. rate: (Where Possible)	CO	ppm	AND	CO <sub>2</sub> %
Comments:					
Signature					

<b>SERVICE 09</b>					Date:
Engineer name:					
Company name:					
Telephone No:					
Gas safe register No:					
Record:	At max. rate:	CO	ppm	AND	CO <sub>2</sub> %
	At min. rate: (Where Possible)	CO	ppm	AND	CO <sub>2</sub> %
Comments:					
Signature					

<b>SERVICE 10</b>					Date:
Engineer name:					
Company name:					
Telephone No:					
Gas safe register No:					
Record:	At max. rate:	CO	ppm	AND	CO <sub>2</sub> %
	At min. rate: (Where Possible)	CO	ppm	AND	CO <sub>2</sub> %
Comments:					
Signature					

\*All installations in England and Wales must be notified to Local Authority Building Control (LABC) either directly or through a Competent Persons Scheme. A Building Regulations Compliance Certificate will then be issued to the customer.

## INSTALLATION CHECKLIST

### SINGLE BOILER INSTALLATION

**PAR 14** (See section 2.6.6) When BMS input used, and input is 10v, the required flow temperature =  °C Set value of PAR 14

### BOILERS INSTALLED IN CASCADE

#### ALL BOILERS IN THE CASCADE

**PAR 15** (see fig 4/b) The cascade address must be set in each boiler in the cascade, denoting the master and each slave ( Master = 0)

Boiler 1	Boiler 2	Boiler 3	Boiler 4	Boiler 5	Boiler 6
Set value of PAR 15					

**PAR 1** (see section 2.2.2) When installed with a cascade flue, incorporating a clappet( non return) valve, PAR 1 must be set accordingly on each boiler in the cascade

Boiler 1	Boiler 2	Boiler 3	Boiler 4	Boiler 5	Boiler 6
Set value of PAR 1					

#### MASTER BOILER

**OEM A1** (see section 2.2.2) When the number of boilers in the cascade is greater than two, the OEM A1 on the MASTER boiler (boiler with PAR 15=0), must be set to the same value as the number of boilers in the cascade. This can only be done after PAR 15 has been set.

Number of boilers in cascade   
 Set value of OEMA1  on boiler number

**PAR 14** (See section 2.6.6) When BMS input used, and input is 10v, the required flow temperature =  °C Set value of PAR 14  on the master boiler

# Commissioning Checklist for Boilers in Cascade

This checklist is for guidance only, and is not a full installation safety check

Address \_\_\_\_\_

Engineer \_\_\_\_\_

	1	2	3	4	5	6	7	8
Satisfactory visual check of flue Y/N								
Flue within allowable length and correctly terminated Y/N								
Confirm Tightness of installation pipework downstream of Isolating valve using leak detection fluid Y/N								
Check tightness of all valves Y/N								
Carryout ignition test of boiler with gas isolated to ensure boiler fails safe Y/N								
Turn on gas supply to boiler and isolate main burner(disconnect gas valve) and ensure boiler goes to lockout Y/N								
Reset boiler lockout and retry, ensuring boiler again locks out Y/N								
Reconnect gas valve, reset boiler lockout, and ensure boiler lights and is stable Y/N								
Test safety devices Y/N								
Safety stat(TS) - Disconnect - the boiler locks out Y/N								

Flue analysis	Boiler 1		Boiler 2		Boiler 3		Boiler 4		Boiler 5		Boiler 6		Boiler 7		Boiler 8		
	Min	Max	Min	Max	Min	Max	Min	Max	Min	Max	Min	Max	Min	Max	Min	Max	
Boiler Output																	
CO ppm																	
CO2 %																	
Ratio																	
Boiler size																	
Serial Number																	
Completed By																	
Date																	

## 5 FAULT FINDING

If an electrical fault occurs on the appliance the preliminary electrical system checks must be carried out first.

When any service or replacement of electrical components which has required the breaking and re-making of electrical connections has taken place, the following tests must be repeated:

- earth continuity;
- short circuit;
- polarity;
- resistance to earth.

### 5.1 EARTH CONTINUITY CHECK

Appliances must be electrically disconnected, meter set on  $\Omega$  (ohm) x 1 scale and adjust zero if necessary. Test leads from any appliance earth point (e.g. inside control box) see wiring diagrams (section 7) to earth pin on plug.

Resistance should be less than 1  $\Omega$  (ohm). If the resistance is greater than 1  $\Omega$  (ohm) check all earth wires for continuity and all contacts are clean and tight. If the resistance to earth is still greater than 1  $\Omega$  (ohm) then this should be investigated further.

### 5.2 SHORT CIRCUIT CHECK

Switches turned FULL ON - meter set on  $\Omega$  (ohms) x 1 scale. Test leads from L to N on appliance terminal block, if meter reads 0 then there is a short circuit.

Meter set on  $\Omega$  (ohm) x 100 scale. Repeat it with leads from L to E. If meter reads less than infinity ( $\infty$ ) there is a fault.

**NOTE: Should it be found that the fuse has failed but no fault is indicated, a detailed continuity check (i.e. by disconnecting and checking each component) is required to trace the faulty component. It is possible that a fault could occur as a result of local burning/arc-ing but no fault could be found under test. However, a detailed visual inspection should reveal evidence of burning around the fault.**

### 5.3 POLARITY CHECK

Appliance reconnected to mains supply and meter set on 300 V ac scale. Test at appliance terminal block.

- Test leads from L to N meter reads

approx.: 240 V ac.

- Test leads from L to E " \* " meter reads approx. 240 V ac.
- Test leads from N to E " \* " meter reads from 0 to 15 V ac.

### 5.4 RESISTANCE TO EARTH CHECK

Appliance must be disconnected from main supply and meter on  $\Omega$  (ohm) x 100 scale.

All switches including thermostat on test leads from L to E - if meter reads other than infinity ( $\infty$ ) there is a fault which should be isolated.

A detailed continuity check is required to trace the faulty component.

#### **IMPORTANT:**

**These series of checks are the first electrical checks to be carried out during a fault finding procedure. On completion of the service/fault finding task which has required the breaking and remaking of electrical connections then the checks 5.1 Earth continuity, 5.3 Polarity and 5.4 Resistance to earth must be repeated.**

## 6 REPLACEMENT OF PARTS

The boiler certification and warranty will be void should spares or replacement parts be used that are not supplied by Sime Ltd and only suitable qualified personnel are permitted to work on gas appliances.

Ensure that the boiler is isolated from the gas and electrical supply before commencing work. Use appropriate personal safety equipment and be aware of hot surfaces and hot water.

Close the flow and return valves, and use the drain vents provided before removal of any part of the hydraulic circuit.

The boiler shell can be removed to improve access, see 4.4

The control panel can be lowered after removal of the securing screw.

### 6.1 BURNER INSPECTION

Isolate the electrical and gas supply.

Lower the control panel.

Disconnect the ignition and ionisation electrodes.

Disconnect the air inlet to the fan.

Disconnect the gas connection at the fan.

Disconnect the two electrical connections from the fan.

While supporting the assembly, remove the four nuts securing the burner plate.

Carefully remove the burner / fan assembly from the heat exchanger.

Inspect the internal section of the heat exchanger, clean if required using a soft brush and vacuum cleaner.

Inspect the burner seals and insulation, replace if damaged.

Check the position and condition of the ignition and ionisation electrodes, replace if required.

Refit in reverse order.

On completion a flue gas analysis must be taken. See section 4- Commissioning.

### 6.2 FAN

Remove the burner / fan assembly as described in 6.1.

Remove the four fixing bolts and remove the fan.

Transfer the air inlet connector to the new fan.

Inspect the gasket and replace if necessary.

Fit the fan and replace in reverse order.

On completion a flue gas analysis must be taken. See section 4- Commissioning.

### 6.3 PUMP

Isolate the electrical and gas supply.

Lower the control panel.

Where possible to improve access, remove the RHS panel, see 4.4

Isolate the flow and return valves, and drain the boiler using the drain vents provided.

Protect any electrical equipment from possible spills of system water.

Disconnect the electrical connection.

Remove the pump noting its orientation.

Fit the new pump in the reverse order, using new washers, ensuring it is oriented in the correct direction.

### 6.4 WATER PRESSURE TRANSDUCER

Isolate the electrical and gas supply.

Lower the control panel.

Where possible to improve access, remove the RHS panel.

Isolate the flow and return valves, and drain the boiler using the drain vents provided.

Protect any electrical equipment from possible spills of system water.

Disconnect the electrical connection.

Unscrew the transducer

Ensure the waterway is clear

Refit in reverse order.

### 6.5 PCB (PRINTED CIRCUIT BOARD)

Isolate the electrical and gas supply.

Lower the control panel.

Remove the PCB covers

Disconnect all the plugs around the circuit board noting positions of single connections.

Remove the PCB fixing screws.

Replace in reverse order

The new or replacement PCB will need to be reconfigured to suit the boiler.

PAR 1 will need to be set according to the gas used

PAR 2 will need to be set according to the boiler configuration

See section 3.3.

Boilers used in cascade may require additional configuration, see installation checklist.

### 6.6 GAS VALVE

Isolate the electrical and gas supply.

Lower the control panel.

Where possible to improve access, remove the LHS panel, see 4.4

Remove the electrical connection to the gas valve.

Remove the air sensing tube, noting its position.

Disconnect the gas cock.

Remove the gas valve securing screws at base of boiler.

Disconnect the gas connection at then fan

Remove the pipework from the gas valve and fit to the replacement valve.

Replace the gaskets as required.

Replace in reverse order.

On completion the gas valve will require adjustment. See section 4.

### 6.7 FLOW SENSORS (SM)

Isolate the electrical and gas supply.

Lower the control panel.

Where possible to improve access, remove the RHS panel, see 4.4

Isolate the flow and return valves, and drain the boiler using the drain vents provided.

Protect any electrical equipment from possible spills of system water.

Disconnect the electrical connection to the sensor.

Unscrew the sensor

Refit in reverse order.

### 6.8 RETURN SENSOR (SR)

Isolate the electrical and gas supply.

Lower the control panel.

Disconnect the electrical connection to the sensor.

Unclip the sensor from the pipe.

Refit in reverse order.

### 6.9 SAFETY STAT

Isolate the electrical and gas supply.

Lower the control panel.

Disconnect the electrical connection.

Remove the two fixing screws.

Apply heat conducting paste to the replacement stat.

Refit in reverse order.

### 6.10 EXHAUST SENSOR (SF)

Isolate the electrical and gas supply.

Disconnect the exhaust sensor.

Unscrew the exhaust sensor from the heat exchanger.

Refit in reverse order.

### 6.11 IGNITION TRANSFORMER

Isolate the electrical and gas supply.

Disconnect the electrical connections from the ignition transformer.

Remove the securing screws.

Replace in reverse order.

### 6.12 IGNITION ELECTRODE

Isolate the electrical and gas supply.

Disconnect the ignition electrode wiring from the ignition transformer.

Remove the Ignition electrode fixing screws.

Remove the ignition electrode.

Check the gasket and replace if required.

Refit in reverse order.

### 6.13 IONISATION ELECTRODE

Isolate the electrical and gas supply.

Disconnect the ionisation electrode wiring.

Remove the ionisation electrode fixing screws.

Remove the ionisation electrode.

Check the gasket and replace if required.

Refit in reverse order.

### 6.14 SAFETY DISCHARGE VALVE

Isolate the electrical and gas supply.

Lower the control panel.

Where possible to improve access, remove the RHS panel, see 4.4

Isolate the flow and return valves, and drain the boiler using the drain vents provided.

Protect any electrical equipment from possible spills of system water.

Disconnect the discharge pipe.

Disconnect the safety discharge valve.

Remove the washer.

Replace in reverse order using a new washer.

# 7 EXPLODED VIEWS

MURELLE HE 50 R / MURELLE HE 50 R M

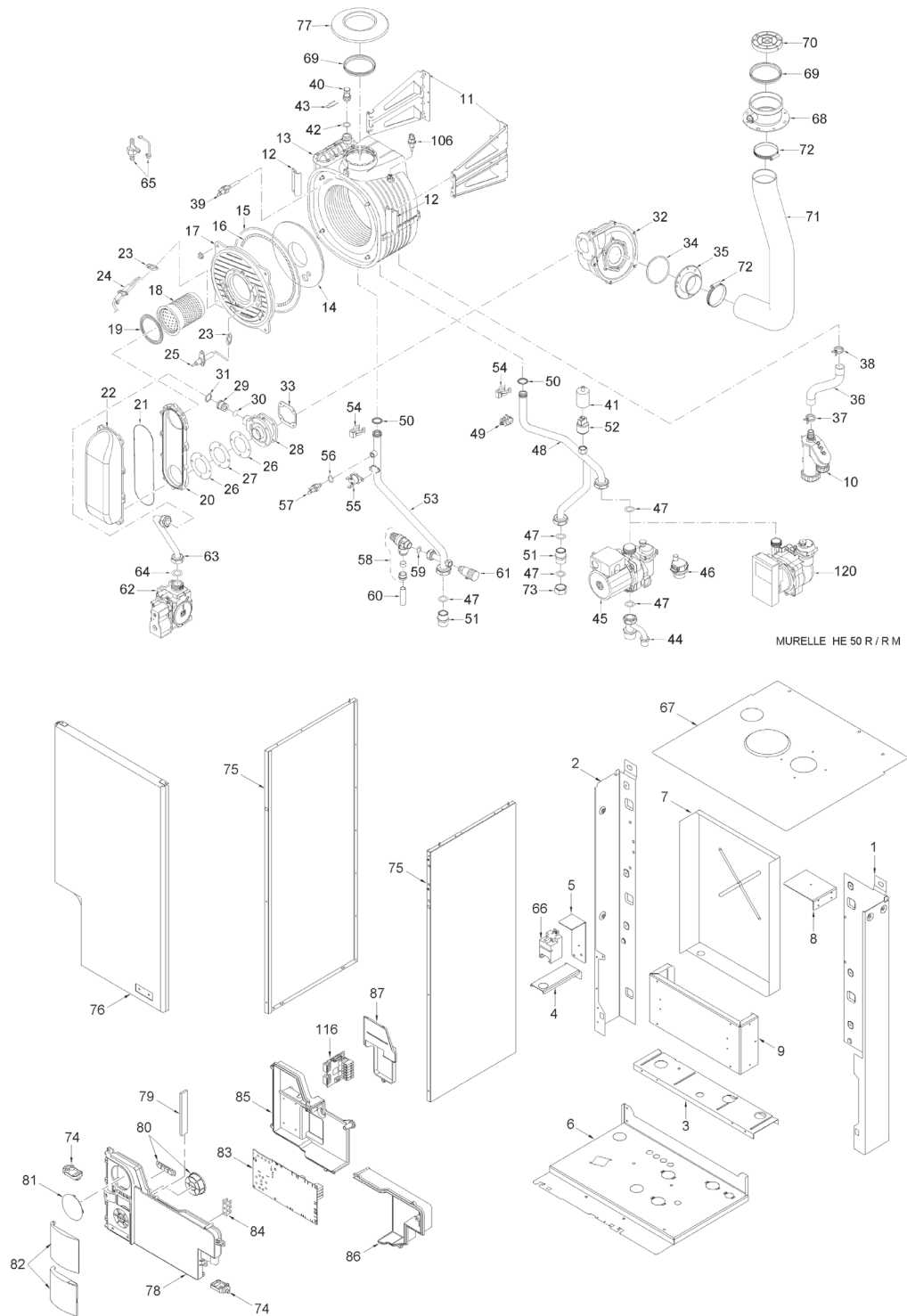

Kit compensatore idraulico / sicurezza ISPSEL (Italia)  
Murelle HE 50 R / R M

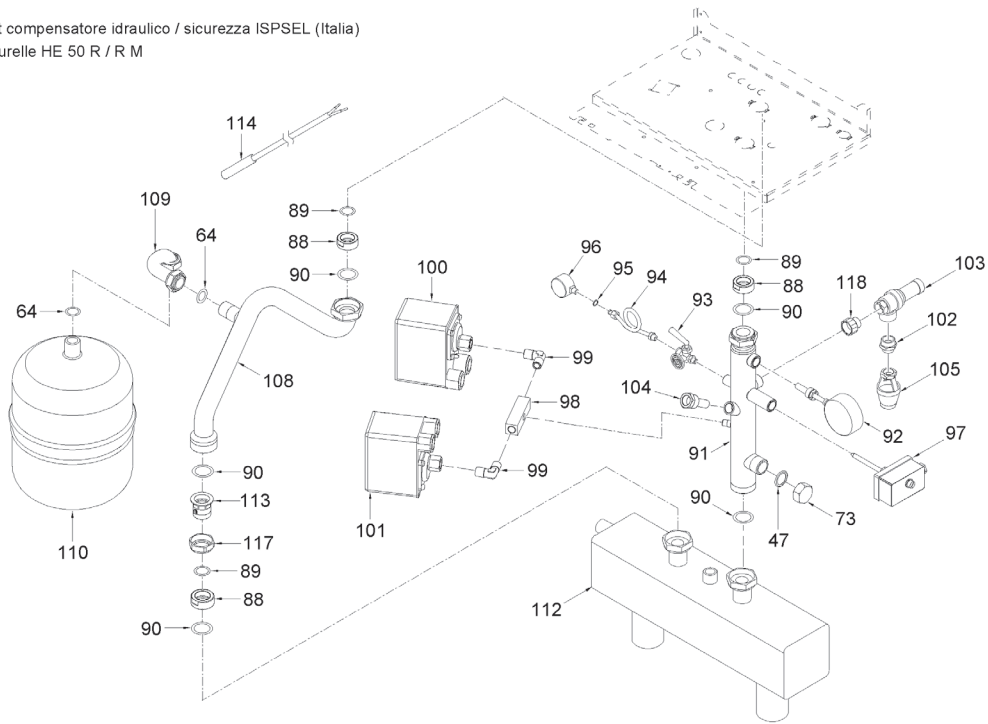

UK - Hydraulic compensator kit (Export)  
FR - Kit compensateur hydraulique (Etranger)  
ES - Kit compensador hidráulico (Extranjero)  
Murelle HE 50 R / R M

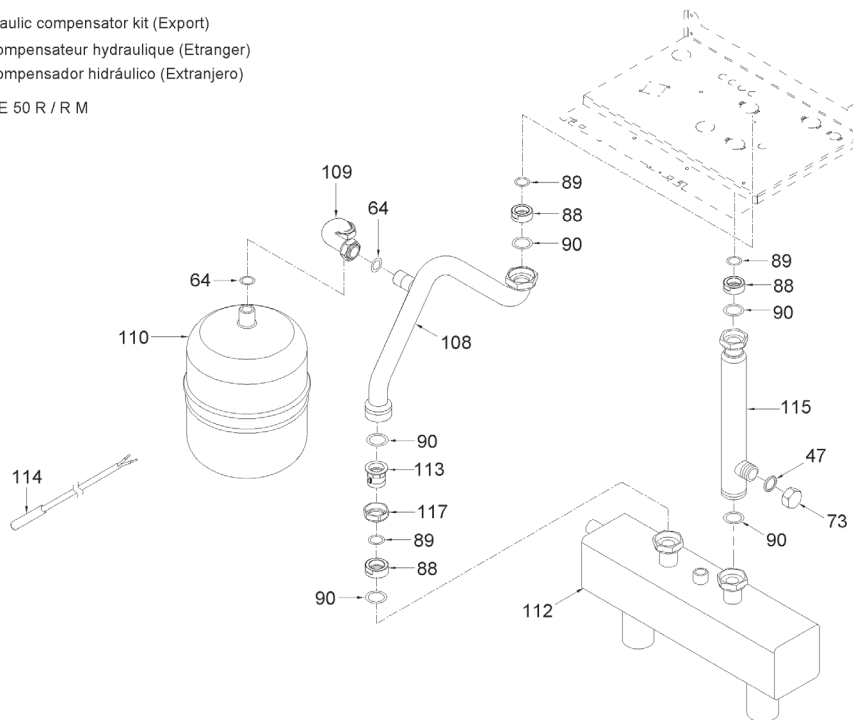

Posiz.	Codice	Descrizione
001	6138533	Right hand side frame part
002	6138632	Left hand side frame part
003	6255431	Expansion vessel lower support
004	6010864	Water trap bracket
005	6256750	Transformer fixing bracket
006	6138897	Frame assembly lower side
007	6266081	Rear panel
008	6256751	Upper protection fixing bracket
009	6267131	Main exchanger supporting brack
010	6277207	Water trap
011	6010860	Main exchanger supporting brack
012	6010829	Main exchanger fixing bracket
013	6278917	Main exchanger body
014	6269011	Main exchanger door insulation
015	6248861	Combustion chamber O-ring
016	6248860	Glass fibre sealing cord

018	6278361	Burner	
019	6174823	Gasket for burner flange	
020	6278891	Side low air-gas hose	
021	6174819	Air-gas hose gasket	
022	6278890	Air-gas hose cover	
023	6174809	Gasket for ignition electrode	
024	6221632	Ignition electrode	
025	6221623	Ionisation electrode	
026	6174812	Mixer/hose gasket	
027	6239206	Mixer closing plate	
028	6274307	Air/gas mixer	
029	6274122	Main burner nozzle 750	MET
029A	6274121	Burner nozzle $\phi$ 6,00	GPL
030	6226414	O-ring 117 $\phi$ 13,1x2,62	
031	2030228	Gasket $\phi$ 17x24x2	
032	6261405	Fan	
033	6174816	Gasket for fan flange	
034	6226410	O-Ring $\phi$ 63 x 3	
035	6083055	Duct flange 60	
036	6034155	Condensate drainage pipe	
037	2051122	Clamp diam. 22,1	
038	2051123	Clamp diam. 24,2	
039	6277130	Probe NTC D.4X40	
040	6147412	Plug for air vent connection	
041	6175401	Cover for micro switches	
042	6226464	O-ring 115 diam. 11,91x2,62	
043	6226624	Spring air vent knob	
044	6277943	Pipe conn. C.H. flow - pump	
045	6124822	Circulating pump	MURELLE HE 50 R
046	6013182	Automatic air vent	
047	2030257	Gasket diam. 30x22x3	
048	6277944	Pipe connecting pump-exchanger	
049	6231360	Temperature sensor	
050	6226412	O-ring 3068	
051	6120540	Nipple 1"x1" OT	
052	6273603	Water press.transd. HUBA CONTR	
053	6227438	Flowing pipe to C.H. system	
054	6226619	Spring for heat exchanger conne	
055	6146701	100°C safety stat	
056	6022010	Sensor gasket	
057	6231351	Plunged sensor	
058	6040206	Pressure relief valve 1/2" 4 ba	
059	2030255	Gasket $\phi$ 12,5x18,5x3	
060	6157623	Pressure relief valve drain pip	
061	6017211	Manual air vent 1/4"	
062	6243837	Gas valve	
063	6277425	Pipe connecting gas valve-mixer	
064	2030249	Gasket $\phi$ 24x17x3	
065	6280590	Three way fitting + cap kit	
066	6098315	Ignition transformer	
067	6010863	Upper protection	
068	6083061	Flue inlet flange $\phi$ 80	
069	6248802	Gasket $\phi$ 80	
070	6190001	Intake terminal $\phi$ 80	
071	6001152	Air intake pipe 60	
072	2051200	Hose clamp $\phi$ 50-70	
073	6229502	Plug 1" F. OT	
074	6302000	Plastic pin	
075	6304461	casing left/right side panel	
076	6304231	Casing front panel	
077	6230402	External ring for pipe diam.80	
078	6304700	Control panel	
079	6305160	Guidelight with led	
080	6305120	Kit Rubber button	
081	6247327	Cap for time programmer	
082	6304890	Flap door assembly	
083	6301480	Main PCB	
084	2211610	Earth faston	
085	6305000	Cover	
086	6305010	connection cover	
087	6305020	Time programmer cover	
088	6120522	Reducer 1"1/2 x 1"	
089	2030222	Piracriten gasket 23x33x3	
090	2030206	Piracriten gasket $\phi$ 33,5x45x2	
091	6291966	ISPESL safeties pipe	
092	6146004	Thermometer 0-120°C	
093	6216606	Manometer cock ISPESL 1/4"	



094	6216650	Manometer cock connection pipe	
095	2030225	Gasket Ø 5,5x11x2	
096	6217050	Manometer 0/6 bar	
097	6001409	H.L. stat 100°C	
098	6291981	Water pressure switch block	
099	6291982	90° MM G 1/4" curve	
100	6037551	Min.m.reset water press.switch	
101	6037550	Safety m.reset water pres.switc	
102	6120502	Nipple 3/4"x3/4" OT	
103	6042207	Security valve 1/2"X3/4"	
104	5064600	Bulb holder 1/2" L=50	
105	6269402	Tundish	
106	6146723	Thermo-fuse 167°C	
108	6227439	C.H. return pipe	
109	6227680	Pipe connecting D.H.W. expans.	
110	6245108	D.H.W. expansion vessel l. 8	
112	6216312	Hydraulic compensator	
113	6238301	Check valve 1" ART. 4001 DN	
114	6231331	D.H.W. tank sensor	
115	6291967	C.H. flow pipe	
116	6301465	PCB expansion	
117	2040302	Brass nut 1-1/2"	
118	6120544	Spigot reducer 1/2"M.x 3/4"F.	
120	6272321	Modulating circulating pump	MURELLE HE 50 R M
700	5185136	LPG conversion kit	
701	5197140	Complete control panel	MURELLE HE 50 R
702	6127214	Main cable L=1500	
703	6186587	Ionisation electrode cable	
704	6319163	3 pole cable connector	
705	6319162	4 pole cable connector	
706	6319161	5 pole cable connector	
707	6319164	9 pole cable connector	
708	6319160	14 pole cable connector	
709	6299991	4 pole cable connector CN12	
710	6316202	Connector 4 poli CN6	
711	6316203	Connector 4 poli CN4	
712	6316204	Connector 8 poli CN7	
713	6319165	5 pole cable connector	
714	5197119	Control panel x modul.circul.pu	MURELLE HE 50 R M
715	6319147	Modul.pump 3 pole female connec	MURELLE HE 50 R M

## **INDUSTRY GUIDANCE FOR INSTALLERS ON CONDENSATE**

### **DRAINAGE PIPE INSTALLATION**

This guidance is endorsed by HHIC members.

#### **1. BACKGROUND**

During recent winters the UK has experienced prolonged spells of extremely cold weather - down to minus 20°C and below in many areas. This resulted in a significant increase in the number of calls to boiler manufacturers and heating engineers from householders with condensing (high efficiency) boilers where the condensate drainage pipe had frozen and become blocked with ice, causing the boiler to shut down. In the vast majority of cases such problems occur where the condensate drainage pipe is located externally to the building for some part of its length.

British Standards, Building Regulations etc. currently allow condensate drainage pipes to be run either internally or externally, or a combination of these. These documents give guidance on how to install the pipes in order to reduce the possibility of freezing. However this guidance may not be sufficient to prevent freezing in extreme conditions - with widespread and prolonged very low temperatures.

In view of the possibility that UK weather patterns will show more “extremes” in future due to the effects of global climate change, the following guidance updates previous recommendations on condensate drainage pipe installation. All other technical requirements for condensate drain installation given in British Standard BS 6798:2009, or in boiler manufacturers’ installation instructions should still be followed.

#### **2. REVISED GUIDANCE ON CONDENSATE DRAINAGE PIPE INSTALLATION**

Where a new or replacement boiler is being installed, access to an internal “gravity discharge” termination should be one of the main factors considered when determining potential boiler locations, so that the condensate drainage pipe can be terminated as recommended below. On an existing installation, the guidance below should also be followed if work is carried out to “upgrade” the condensate drainage system to reduce the risk of freezing in extreme conditions.

Internal condensate drainage pipework must be a minimum of 19mm ID (typically 22mm OD) plastic pipe and this should “fall” at least 45 mm per metre away from the boiler, taking the shortest practicable route to the termination point.

In order to minimise the risk of freezing during prolonged very cold spells, one of the following methods of terminating condensate drainage pipe should be adopted -

## **2.1 INTERNAL TERMINATION:**

Wherever possible, the condensate drainage pipe should be terminated at a suitable internal foul water discharge point such as (a) an internal soil and vent stack or (b) an internal kitchen or bathroom waste pipe, washing machine waste pipe etc. A suitable permanent connection to the foul waste pipe should be used. Figures 1, 2(a), 2(b) show appropriate connection methods.

The possibility of waste pipes freezing downstream of the connection point should be considered when determining a suitable connection point - e.g. a slightly longer pipe run to an internal soil stack may be preferable to a shorter run connecting into a kitchen waste pipe discharging directly through the wall to an external drain.

Where "gravity discharge" to an internal termination is not physically possible (e.g. the discharge point is above the appliance location, or access is obstructed by a doorway), or where very long internal pipe runs would be required to reach a suitable discharge point, the following measures may be adopted -

## **2.2 USE OF A CONDENSATE PUMP (TO AN INTERNAL TERMINATION):**

Condensate can be removed using a proprietary condensate pump, of a specification recommended by the boiler or pump manufacturer.

The pump outlet should discharge to a suitable internal foul water discharge point, such as (a) an internal soil and vent stack or (b) an internal kitchen or bathroom waste pipe, washing machine waste pipe etc. Figure 3 shows a typical connection method.

A suitable permanent connection to the foul waste pipe should be used and the manufacturer's detailed installation instructions for the pump should be followed.

## **2.3 EXTERNAL TERMINATION:**

The use of an externally-run condensate drainage pipe, terminating at a suitable foul water discharge point or purpose-designed soakaway, may be also be considered; however if this termination method is chosen then the following measures should be adopted -

The pipe should be run internally as far as possible before going externally and the pipe diameter should be increased to a minimum of 30mm ID (typically 32mm OD) before it passes through the wall.

The external run should be kept as short as possible, taking the most direct and "most vertical" route possible to the discharge point, with no horizontal sections in which condensate might collect.

The external pipe should be insulated using suitable waterproof and weatherproof insulation ("Class O" pipe insulation is suitable for this purpose) .

The use of fittings, elbows etc should be kept to a minimum and any internal “burrs” on cut pipework should be removed so that the internal pipe section is as smooth as possible.

The customer/householder should be advised that even with the above measures this type of installation could freeze, and that if this were to occur then boiler shutdown could result, requiring remedial action - possibly involving a chargeable engineer call-out.

Where there are likely to be extremes of temperature or wind-chill, the use of a proprietary trace-heating system for external condensate drainage pipework, incorporating an external frost thermostat, should therefore be considered. If such a system is used then the installation instructions of the trace heating manufacturer and any specific recommendations regarding pipe diameter, insulation, etc. should be followed. All other relevant guidance on condensate drainage pipe installation should also be followed.

*Other cold weather protection methods approved or endorsed by boiler manufacturers and/or service organisations may be adopted if these are considered suitable by the parties involved.*

If an external soil/vent stack is used as the external termination then the connection method shown in Figure 4 should be used, together with the measures on insulation etc. as described above and shown in the diagram.

When a rain water downpipe is used as the termination (**NB** only permissible if this downpipe passes to a combined foul and rainwater drainage system) an air break must be installed between the condensate drainage pipe and the downpipe to avoid reverse flow of rainwater into the boiler should the downpipe itself become flooded or frozen. Figure 5 shows a suitable connection method.

Where the condensate drainage pipe is terminated over an open foul drain or gully, the pipe should terminate below the grating level, but above water level, in order to minimise “wind chill” at the open end. Pipe drainage will be improved if the end is cut at 45° as opposed to a straight cut. The use of a drain cover (such as those used to prevent blockage by leaves) may offer further protection from wind chill. Figure 6 shows a suitable connection method.

Where the condensate drain pipe terminates in a purpose-designed soakaway (see BS 6798:2009 or boiler installation manual for soakaway design requirements) any above-ground section of condensate drainage pipe should be run and insulated as described above. Figure 7 shows a suitable connection method.

### **3. UNHEATED INTERNAL AREAS:**

Internal condensate drainage pipes run in unheated areas such as lofts, basements and garages should be treated as external pipe.

## NOTES

*The Benchmark Commissioning Checklist should be completed as required to record details of the condensate drainage pipe installation.*

*Where an external condensate drainage pipe is installed, the customer should be made aware of the risks and consequences of its freezing and offered the option to fit trace heating (or other measures approved by the boiler manufacturer or service organisation).*

*Separate guidance has been published for householders on remedial actions which can be taken if a condensate drainage pipe freezes. This may result in requests for alteration to condensate drainage pipework, in which case the guidance above should be followed.*

*In some instances (e.g. where an elderly person's heating needs to be reinstated as an emergency measure) condensate drainage pipes may have been cut in order to bypass any blockage and allow re-ignition of the boiler, with condensate being collected in a suitable container as a temporary solution.*

*While not unsafe, this is not recommended practice and if such action has been taken then the condensate drainage pipe must be reinstated as soon as possible, using the above guidance to reduce risk of freezing in future.*

Figure 1 – Connection of condensate drainage pipe to internal soil and vent stack

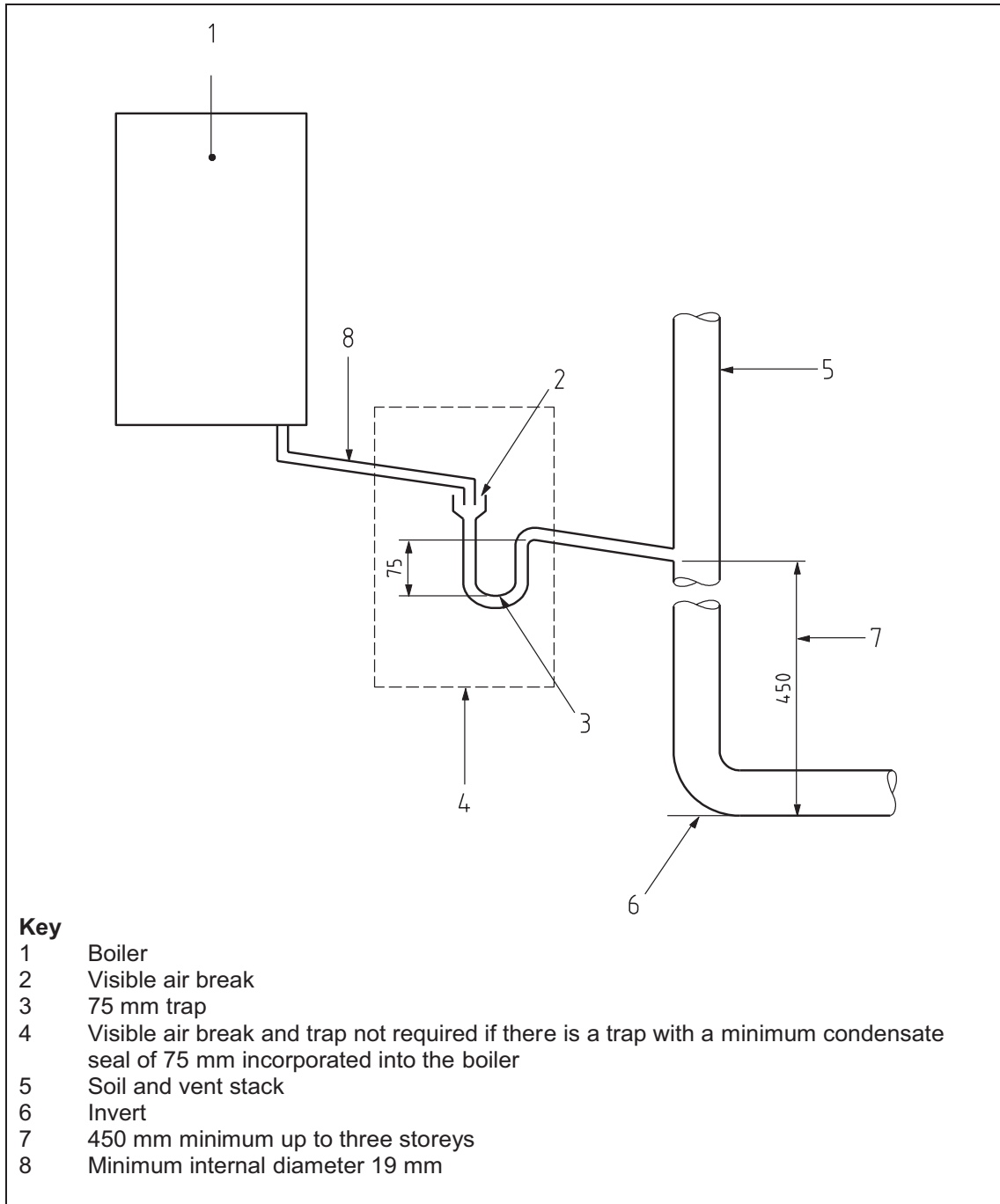

**Figure 2(a) – Connection of a condensate drainage pipe downstream of a sink, basin, bath or shower waste trap**

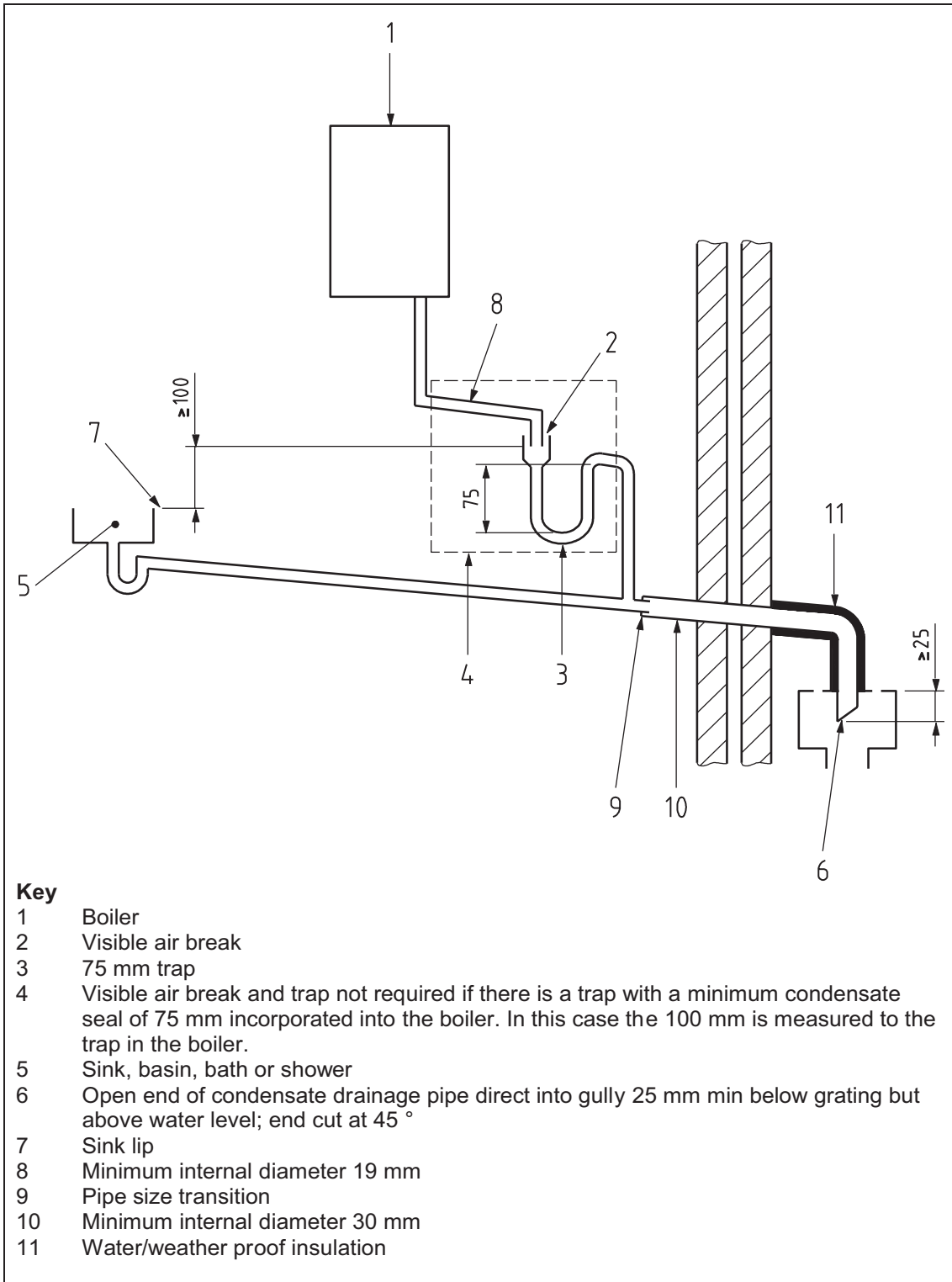

**Figure 2(b) – Connection of a condensate drainage pipe upstream of a sink, basin, bath or shower waste trap**

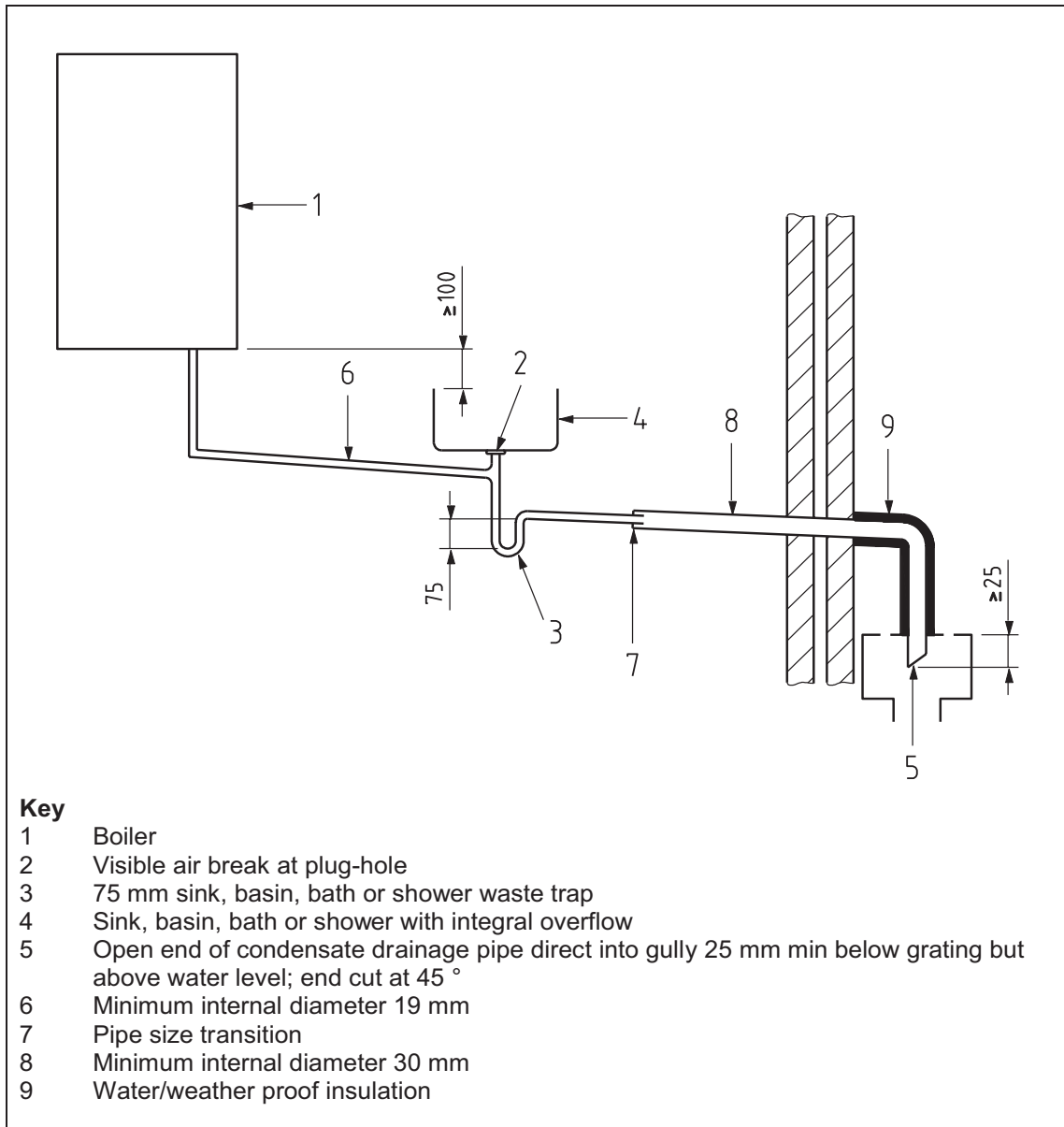



**Figure 3 – Connection of a condensate pump - typical method (NB manufacturer’s detailed instructions should be followed).**

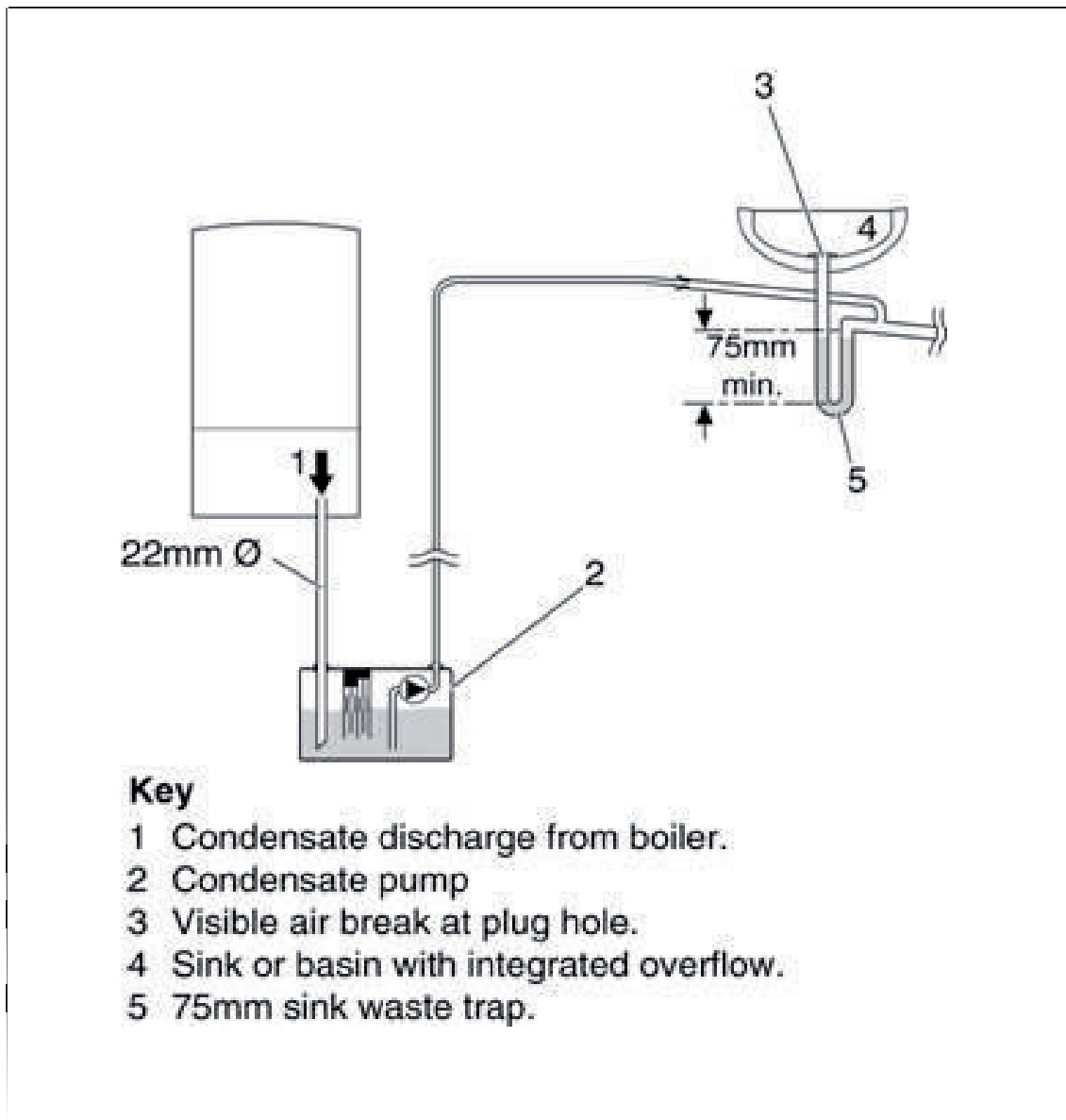

Figure 4 – Connection of condensate drainage pipe to external soil and vent stack

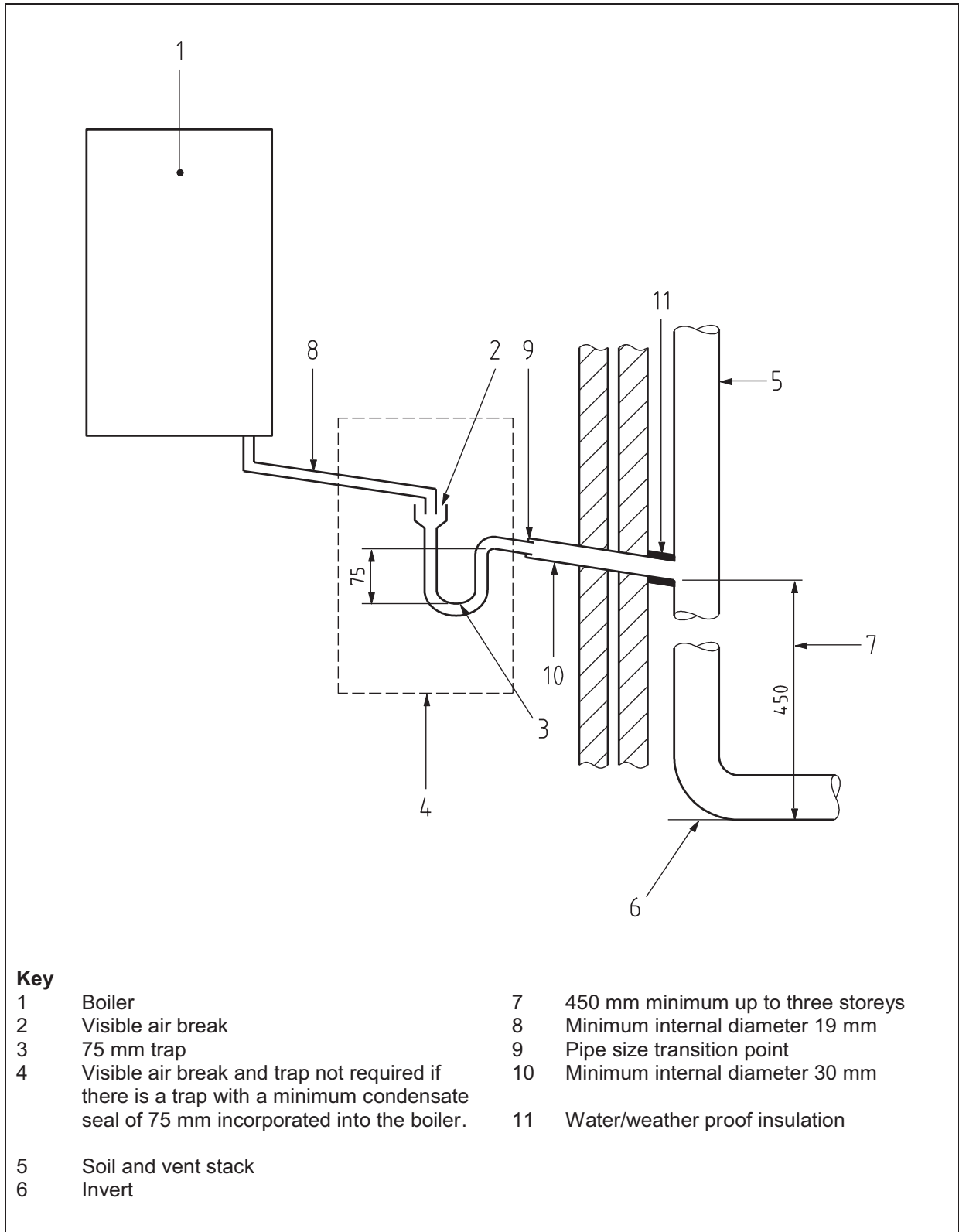

Figure 6 – External drain, gully or rainwater hopper

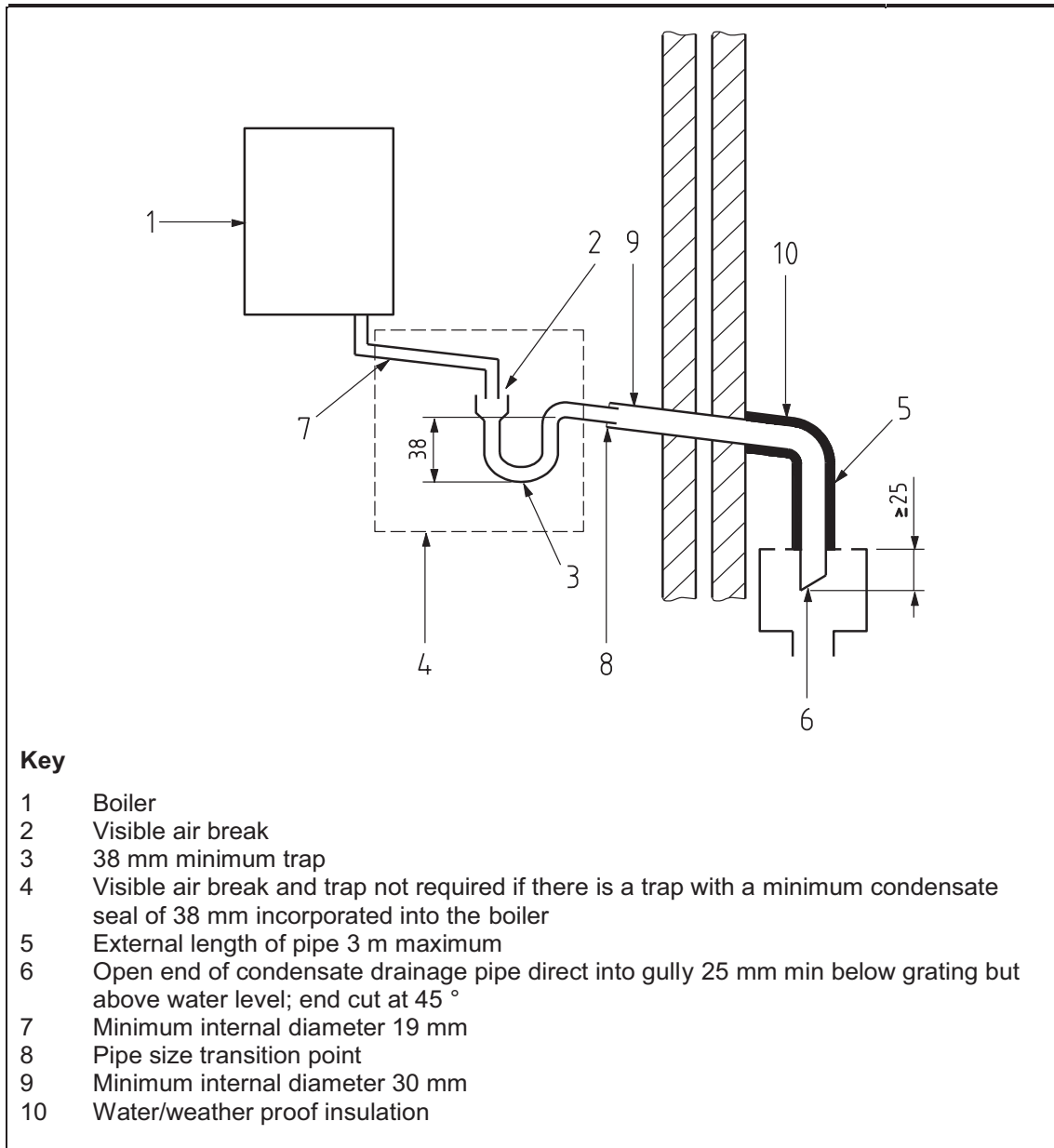

Figure 6 – External drain, gully or rainwater hopper

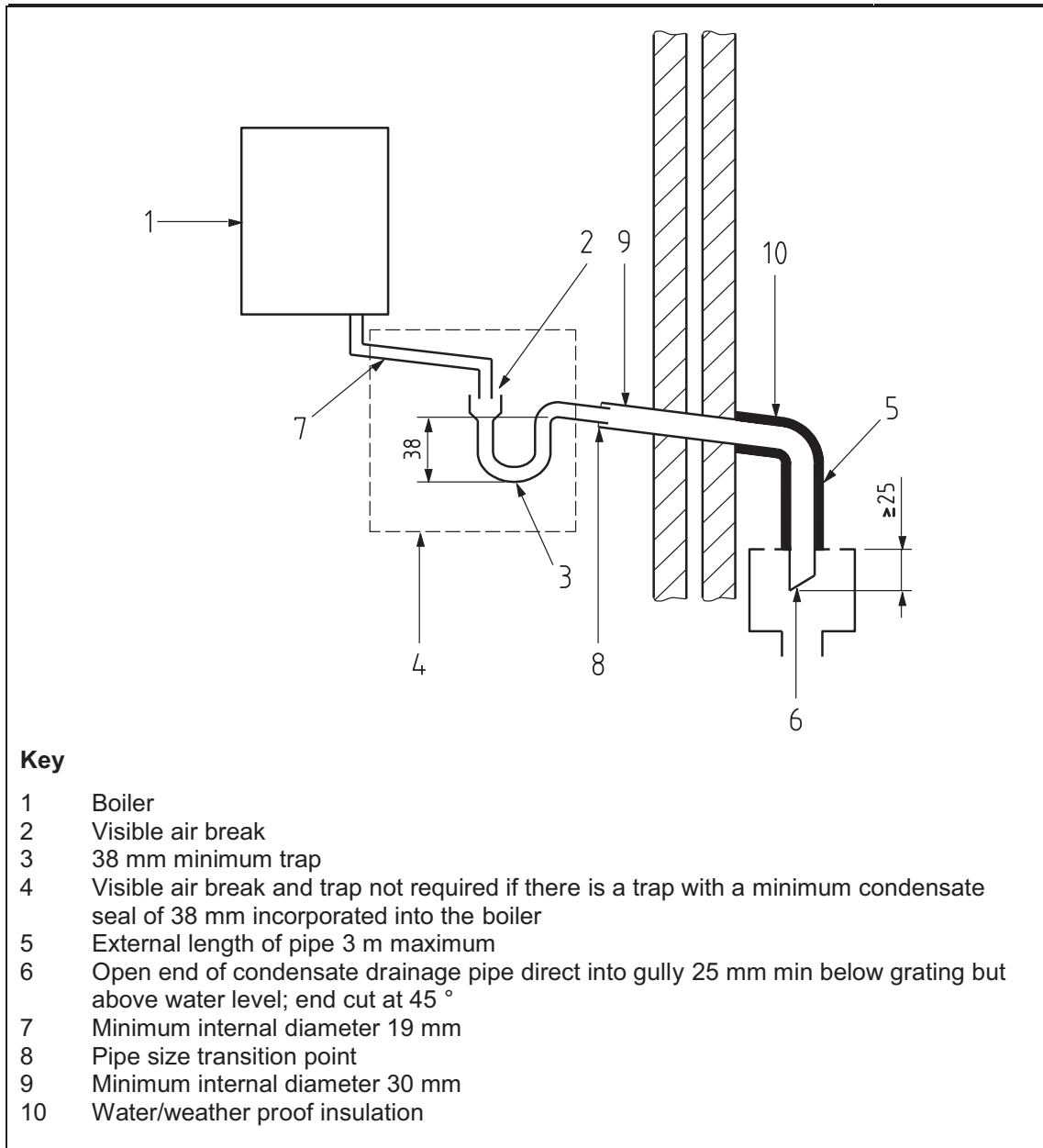
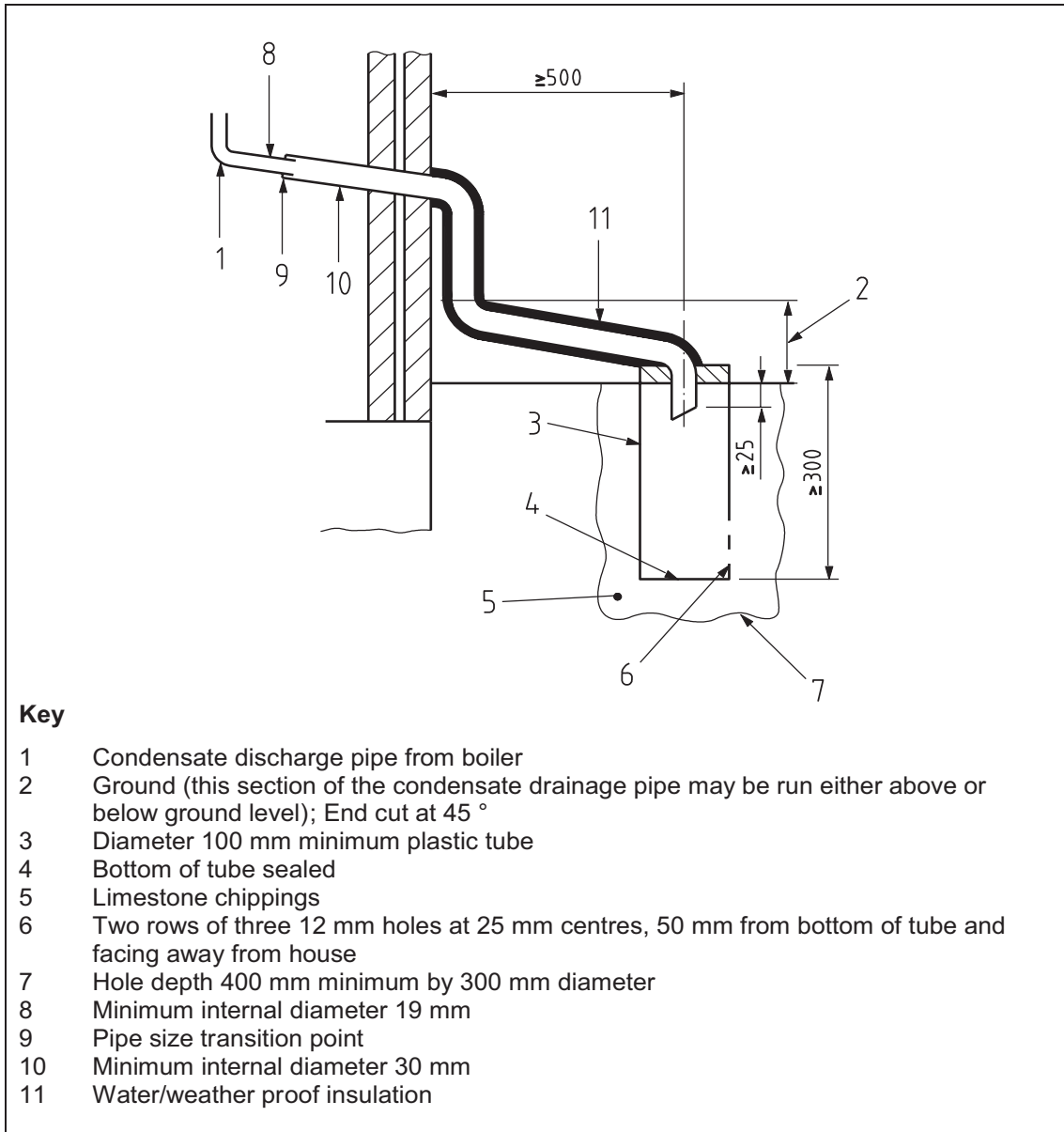

Figure 7 – Example of a purpose-made soakaway



## USER INSTRUCTIONS

### BOILER IGNITION (fig. 24)

The first ignition of the boiler must be carried out by qualified technical personnel. Successively, if it is necessary to start up the boiler again, adhere strictly to the following instructions: open the gas isolation valve to allow the flow of the fuel and move the main switch of the system to "ON".

When fuel is fed to the boiler, a sequence of checks will be carried out and the display shows the normal condition of the functioning, always indicating the pressure of the system.

If the blue luminous bar is on, this indicates the presence of voltage.

Press the key of the controls (pos. 2) to activate the winter function. The display will be as shown in the figure.



**N.B.:** The first key press illuminates the display, successive key presses will be recognised to alter the mode or value..

### REGULATION OF THE WATER TEMPERATURE FOR HEATING (fig. 25)

To set the temperature of the water for heating, press the key of the controls (2). The first time the key is pressed, the SET of heating circuit 1 is selected. The second time it is pressed, the SET of heating circuit 2 is selected. The display will be as shown in the figure.

Change the values with the key and .

Standard visualisation will return to the display by pressing the key again, or after 10 seconds if no key is pressed.

### Regulation of the external sensor (fig. 25/a)

If an external sensor is installed, the value of the output temperature is automatically chosen by the system, which quickly adjusts the environmental temperature on the basis of the external temperature. If you wish to change the value of the temperature, increasing or decreasing that calculated automatically by the electronic card, proceed as indicated in the preceding paragraph. The level of various correction of a value of temperature proportional calculated. The display will be as shown in fig. 25/a.

### TO SWITCH OFF THE BOILER (fig. 24)

In the case of a short absence, press the key of the controls (pos. 2). The di-

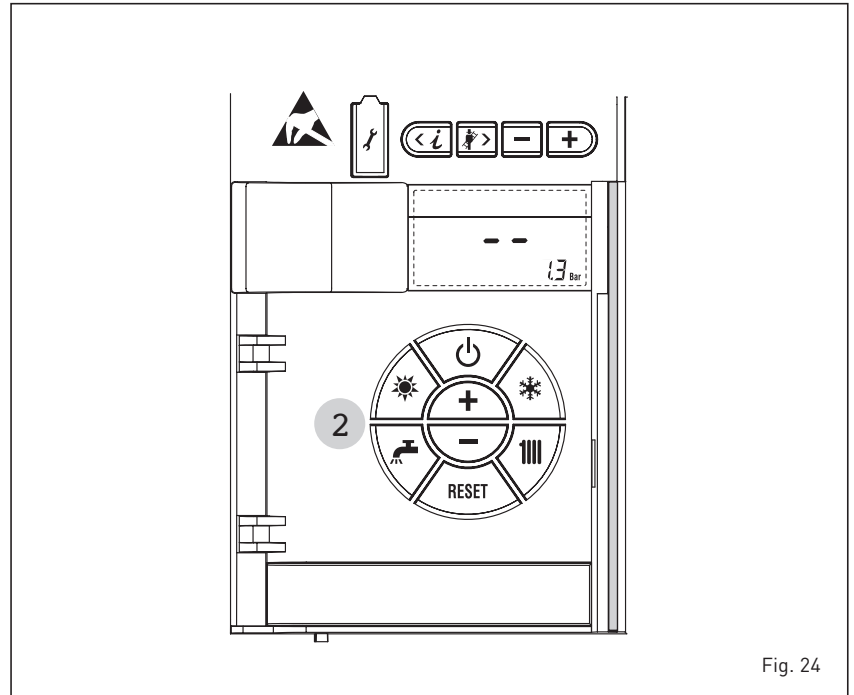

Fig. 24

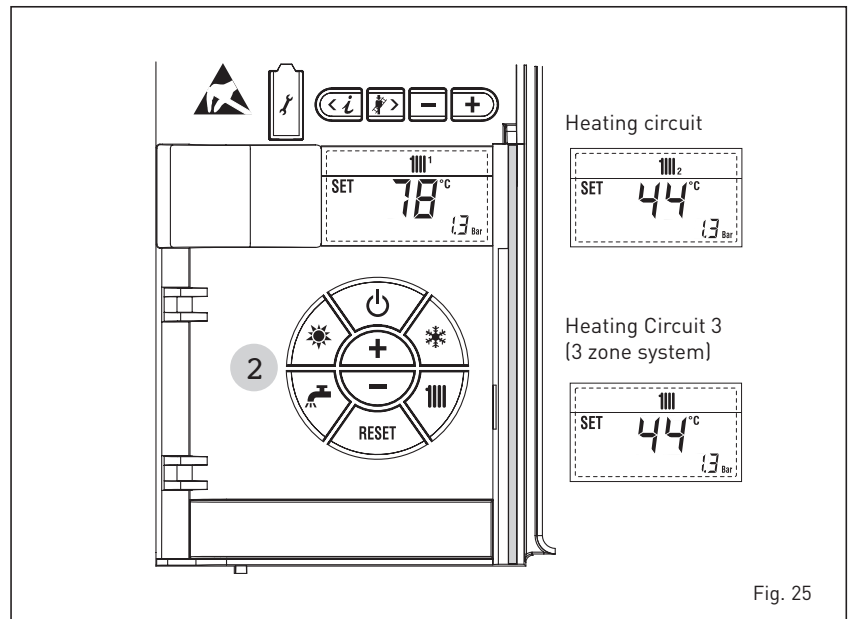

Fig. 25

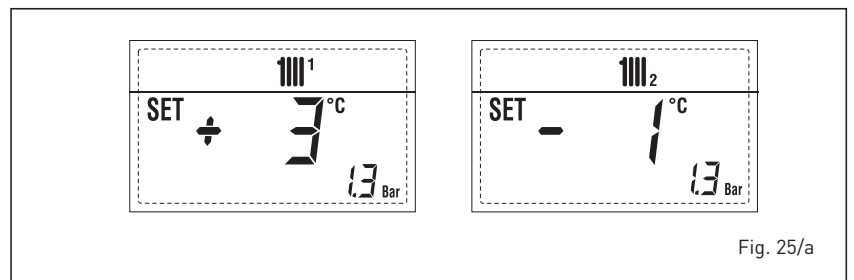

Fig. 25/a

splay will be as shown in the fig. 24. In this way, leaving the electricity and the fuel supply connected, the boiler is protected from frost and from the pump becoming jammed. If the boiler is not used for a prolonged

period, it is advisable to disconnect the electricity supply, by switching off the main switch of the system, and to close the gas tap and, if low temperatures are expected, to completely empty the hydraulic circuits to avoid pipes being

damaged by frost.

## ERRORS AND SOLUTIONS

When there is a functioning anomaly, the display shows an alarm and the blue luminous bar becomes red.

Descriptions of the anomalies with the relative alarms and solutions are given below:

### - ALARM 02 (fig. 27/a)

If the water pressure detected is lower than 0.5 bar, the boiler will stop and the display will show "ALL 02". Using the external filling device, repressurise the heating system until the pressure indicated by transducer is between 1 and 1.5 bar.

**If it is necessary to repeat the system refilling procedure, it is advisable to contact qualified technical personnel to check the soundness of the heating system (to check whether there are any leaks).**

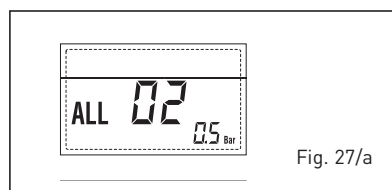

Fig. 27/a

### - ALL 03

**Request assistance from qualified technical personnel.**

### - ALL 05

**Request assistance from qualified technical personnel.**

### - ALL 06 (fig. 27/c)

Press the key  of the controls (2) to re-start the boiler.

**If the error persists, request assistance from qualified technical personnel.**

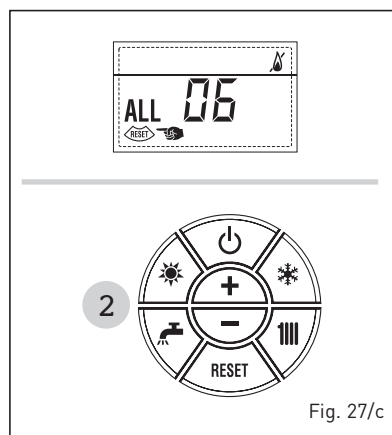

Fig. 27/c

### - ALL 07 (fig. 27/d)

Press the key  of the controls (2)

to re-start the boiler.

**If the error persists, request assistance from qualified technical personnel.**

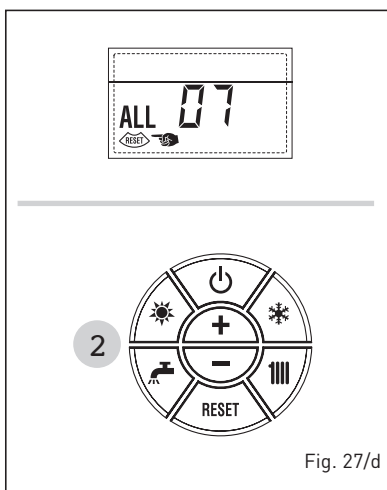

Fig. 27/d

### - ALL 08, ALL 09, ALL 10

**Request assistance from qualified technical personnel.**

### - ALL 13 (fig. 27/e)

Press the key  of the controls (2) to re-start the boiler.

**If the error persists, request assistance from qualified technical personnel.**

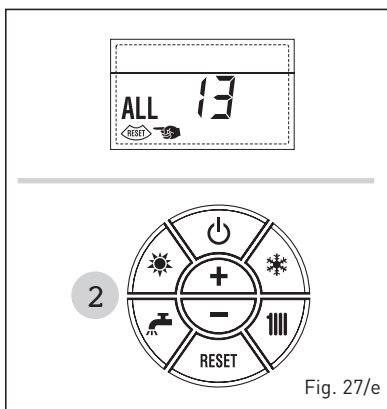

Fig. 27/e

### - ALL 14, ALL 15

**Request assistance from qualified technical personnel.**

### - "⌚ FLASHING"

**If an external sensor (SE) is fitted, should it become short circuited, this symbol will flash on the display. During such error the boiler will continue normal functioning.**

### - From ALL 20 to ALL 35

**Request assistance from qualified technical personnel.**

### - ALL 70 and ALL 71

**These alarms appear on the SIME HOME remote control display. Re-**

**quest assistance from qualified technical personnel.**

## GREEN LED PUMP HIGH EFFICIENCY (fig. 28)

If the LED signal is missing or the colour changes (blinking red/green, blinking red or fixed), contact an authorised technician.

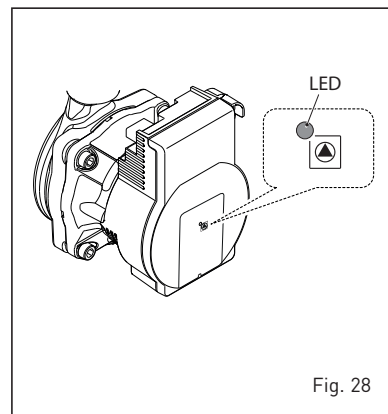

Fig. 28

## GAS CONVERSION

If it is necessary to change to a different type of gas, request assistance only from authorised technical personnel.

## MAINTENANCE

Annual maintenance of the appliance should be planned sufficiently in advance, requesting the assistance of authorised technical personnel.

The boiler is supplied with a mains cable which should only be replaced with one of similar dimensions.

**ATTENTION: It is mandatory that the dedicated power cable is replaced only with a spare cable ordered and connected by professionally qualified personnel.**

## DEMOLITION AND DISPOSAL OF THE APPLIANCE (2012/19/UE)



At the end of its life cycle the appliance **MUST BE DISPOSED AND RECYCLED**, as required by current law.

It **MUST NOT** be disposed of with domestic waste. It

can be taken to waste recycling centres, where they exist, or to a dealer providing this service.

Recycling waste prevents potential damage to the environment and harm to health. It also allows you to recover many recyclable materials with significant economic and energy savings.



## PRODUCT DETAILS

IT

ES

PT

EN

	
<b>Murelle HE</b>	<b>50 R ErP</b>
Classe efficienza energetica stagionale riscaldamento Clase de eficiencia energética estacional en calefacción Classe de eficiência energética do aquecimento ambiente sazonal C.H. energy efficiency class	
Potenza termica (kW) Potencia térmica (kW) Potência calorífica (kW) Heat output (kW)	<b>47</b>
Consumo annuo di energia riscaldamento (GJ) Consumo anual de energía en calefacción (GJ) Consumo anual de energia para aquecimento (GJ) C.H. annual energy consumption (GJ)	<b>87</b>
Efficienza energetica stagionale riscaldamento (%) Eficiencia energética estacional en calefacción (%) Eficiência energética do aquecimento sazonal (%) C.H. seasonal energy efficiency (%)	<b>93</b>
Potenza sonora dB(A) Potencia sonora dB(A) Potência sonora dB(A) Sound power dB(A)	<b>53</b>
<p>Specifiche precauzioni da adottare al momento del montaggio, dell'installazione o della manutenzione dell'apparecchio sono contenute all'interno del manuale istruzioni della caldaia</p> <p>En el manual de instrucciones de la caldera se indican las precauciones específicas que se deben adoptar durante el montaje, la instalación o el mantenimiento del aparato</p> <p>Precauções específicas a tomar no momento da montagem, instalação ou manutenção do aparelho estão contidas no manual de instruções do aquecedor</p> <p>Specific precautionary measures to be adopted at the time of assembly, installation or maintenance of the equipment are contained in the boiler instruction manual</p> <p>Conforme all'allegato IV (punto 1) del regolamento delegato (UE) N° 811/2013 che integra la Direttiva 2010/30/UE</p> <p>Con arreglo al anexo IV (punto 1) del Reglamento Delegado (UE) N° 811/2013 que completa la Directiva 2010/30/UE</p> <p>Em conformidade com o anexo IV (ponto 1) do regulamento delegado (UE) N.º 811/2013 que complementa a Diretiva 2010/30/UE</p> <p>Conforming to Annex IV (item 1) of the Delegated Regulations (EU) No. 811/2013 which supplements Directive 2010/30/EU</p>	



# ANNEX AA.1

## Murelle HE 50 R ErP (Code 8111202)

IT  
ES  
PT  
EN

Informazioni da fornire per le caldaie per il riscaldamento d'ambiente e le caldaie miste Información obligatoria para calderas de calefacción de espacios y calderas mixtas Informações a fornecer para aquecedores de ambiente com caldeira e aquecedores combinados com caldeira Information requirements for boiler space heaters, boiler combination heaters							
Modello / Modelos / Modelos / Model:		MURELLE HE 50 R ErP					
Caldaia a condensazione / Caldera de condensación: Caldeira de condensação / Condensing boiler:		Yes					
Caldaia a bassa temperatura / Caldera de baja temperatura: Caldeira de baixa temperatura / Low-temperature boiler:		Yes					
Caldaia di tipo B11/ Caldera de tipo B11/ Caldeira B11 / B11 boiler:		No					
Apparecchio di cogenerazione per il riscaldamento d'ambiente: Equipo de cogeneración para calefacción de espacios: Aquecedor de ambiente com cogeração: Cogenerator space heater:		No	Munito di un apparecchio di riscaldamento supplementare: Equipado con un aparato de calefacción suplementario: Equipado com aquecedor complementar: Equipped with a supplementary heater:				No
Apparecchio di riscaldamento misto / Equipo de calefacción mixto: Aquecedor combinado / Combunation heater:		No					
Elemento / Elemento Elemento / item	Symbol	Value	Unit	Elemento / Elemento Elemento / item	Symbol	Value	Unit
Potenza termica nominale Potencia térmica nominal Potência calorífica nominal Nominal heat output for space heating	$P_n$	47	kW	Efficienza energetica stagionale del riscaldamento d'ambiente Eficiencia energética estacional de calefacción Eficiência energética do aquecimento ambiente sazonal Seasonal space heating energy efficiency	$\eta_s$	93	%
Per le caldaie per il riscaldamento d'ambiente e le caldaie miste: potenza termica utile Para calderas de calefacción de espacios y calderas mixtas: potencia térmica útil Aquecedores de ambiente com caldeira e aquecedores combinados equipados com caldeira: energia calorífica útil For boiler space heaters and boiler combination heaters: useful heat output				Per le caldaie per il riscaldamento d'ambiente e le caldaie miste: efficienza utile Para calderas de calefacción de espacios y calderas mixtas: eficiencia útil Aquecedores de ambiente com caldeira e aquecedores combinados equipados com caldeira: eficiência útil For boiler space heaters and boiler combination heaters: useful efficiency			
Alla potenza termica nominale e a un regime ad alta temperatura <sup>a</sup> A potencia calorífica nominal y régimen de alta temperatura <sup>a</sup> À potência calorífica nominal e em regime de alta temperatura <sup>a</sup> At nominal heat output and high-temperature regime <sup>a</sup>	$P_4$	46,8	kW	Alla potenza termica nominale e a un regime ad alta temperatura (*) A potencia calorífica nominal y régimen de alta temperatura (*) À potência calorífica nominal e em regime de alta temperatura (*) At nominal heat output and high-temperature regime (*)	$\eta_4$	87,8	%
Al 30% della potenza termica nominale e a un regime a bassa temperatura <sup>b</sup> A 30% de potencia calorífica nominal y régimen de baja temperatura <sup>b</sup> A 30% da potência calorífica nominal e em regime de baixa temperatura <sup>b</sup> At 30% of nominal heat output and low-temperature regime <sup>b</sup>	$P_1$	14,0	kW	Al 30% della potenza termica nominale e a un regime a bassa temperatura (*) A 30% de potencia calorífica nominal y régimen de baja temperatura (*) A 30% da potência calorífica nominal e em regime de baixa temperatura (*) At 30% of nominal heat output and low-temperature regime (*)	$\eta_1$	97,7	%
Consumo ausiliario di elettricità / Consumos eléctricos auxiliares Consumos eléctricos auxiliares / Auxiliary electricity consumption				Altri elementi / Otros elementos Outros elementos / Other items			
A pieno carico A plena carga Em plena carga At full load	$e_{l_{max}}$	0,096	kW	Dispersione termica in standbay Dispersión térmica en stand-by Perdas de calor em modo de vigília Standby heat loss	Pstby	0,076	kW
A carico parziale A carga parcial Em carga parcial At part load	$e_{l_{min}}$	0,024	kW	Consumo energetico del bruciatore di accensione Consumo energético del quemador de encendido Consumo de energia do queimador de ignição Ignition burner power consumption	Pign	0	kW
In modo standby / En modo de espera Em modo de vigília / In standby mode	PSB	0,004	kW	Emissioni di NOx / Emisiones de Nox Emissões de Nox / Emission of nitrogen oxides	NOx	20	mg/kWh
Per gli apparecchi di riscaldamento misto / Para los calefactores combinados / Aquecedores combinados / For combination heaters:							
Profilo di carico dichiarato Perfil de carga declarado Perfil de carga declarado / Declared load profile		--		Efficienza energetica di riscaldamento dell'acqua Eficiencia energética de caldeo de agua Eficiência energética do aquecimento de água Water heating energy efficiency	$\eta_{wh}$	--	%
Consumo quotidiano di energia Consumo diario de electricidad Consumo diário de eletricidade Daily electricity consumption	Qelec	--	kWh	Consumo quotidiano di combustibile Consumo diario de combustible Consumo diário de combustível Daily fuel consumption	Qfuel	--	kWh
Recapiti / Datos de contacto Elementos de contacto / Contact details		Fonderie Sime S.p.A. Via Garbo 27, 37045 Legnago (VR) ITALIA					
<p>a. Regime ad alta temperatura: temperatura di ritorno di 60°C all'entrata e 80°C di temperatura di fruizione all'uscita dell'apparecchio</p> <p>b. Bassa temperatura: temperatura di ritorno (all'entrata della caldaia) per le caldaie a condensazione 30°C, per le caldaie a bassa temperatura 37°C e per le altre caldaie 50°C</p> <p>a. Régimen de alta temperatura: temperatura de retorno de 60°C a la entrada y 80°C de temperatura de alimentación a la salida del aparato.</p> <p>b. Baja temperatura: temperatura de retorno (a la entrada de la caldera) de 30°C para las calderas de condensación, de 37°C para las calderas de baja temperatura y de 50°C para las demás calderas.</p> <p>a. Regime de alta temperatura: temperatura de retorno de 60°C à entrada do aquecedor e temperatura de alimentação de 80°C à saída do aquecedor.</p> <p>b. Baixa temperatura: temperatura de retorno de 30°C para as caldeiras de condensação, 37°C para as caldeiras de baixa temperatura e 50°C para os outros aquecedores (à entrada do aquecedor).</p> <p>a. High-temperature regime means 60°C return temperature at heater inlet and 80°C feed temperature at heater outlet.</p> <p>b. Low-temperature regime means for condensig boilers 30°C, for low-temperature boilers 37°C and for other heaters 50°C return temperature.</p>							
(*) Dati di rendimento calcolati con potere calorifico superiore Hs / Datos de rendimiento calculado con el valor calorífico superior Hs Os valores do desempenho calculados com valor calorífico superior Hs / Performance data calculated with gross calorific value Hs							







**Sime Ltd**

1a Blue Ridge Park  
Thunderhead Ridge  
Glasshoughton, Castleford, WF10 4UA

Phone: 0345 901 1114

Fax: 0345 901 1115

[www.sime.co.uk](http://www.sime.co.uk)

Email: [enquiries@sime.co.uk](mailto:enquiries@sime.co.uk)