

Unical[®]

EVE 05

RTN 24 - RTFS 24

CTN 24 F - CTFS 24 F

CTN 24 - CTFS 24



INSTALLATION USE
AND MAINTENANCE

English

IMPORTANT

This INSTRUCTION MANUAL, which is an integral and indispensable part of the product, must be handed over to the user by the plumbers and must be kept in a safe place for future reference. The manual must be handed over with the boiler should it be sold or transferred.

This boiler must be used for the purposes for which it has been designed. Any other use shall be considered incorrect and therefore dangerous.

The boiler must be installed in compliance with applicable laws and standards and according to the manufacturer's instructions given in this manual. Incorrect installation may cause injury to persons and/or animals and damage to property. The manufacturer shall not be held liable for any such injury and/or damage.

Damage and/or injury caused by incorrect installation or use and/or damage and/or injury due to non-observance of the manufacturer's instructions shall relieve UNICAL from any and all contractual and extracontractual liability.

Before installing the boiler, check that the technical data correspond to requirements for its correct use in the system.

Check that the boiler is intact and that it has not been damaged during transport and handling. Do not install equipment which is patently damaged and/or faulty.

Do not obstruct the air suction and/or heat dissipation grates.

Only original accessories must be used for all boilers supplied with optionals or kits (including electrical ones).

Dispose of the packaging with care as all the materials can be recycled. The packaging must therefore be sent to specific waste management sites.

Keep the packaging out of the reach of children as it may represent a choking and suffocation hazard.

In the event of failure and/or faulty functioning, switch off the boiler. Do not attempt to make repairs: contact qualified technicians.

Original parts must be used for all repairs to the boiler.

Non-observance of the above requirement may jeopardize the safety of the boilers and expose people, animals and property to danger.

To guarantee efficiency and correct functioning of the equipment it is legally binding to service the boilers once a year according to the schedule indicated in the relative section of this manual.

In the event of long periods of inactivity of the boiler, disconnect it from the power mains and close the gas tap (Warning! In this case the boiler's electronic anti-freeze function will not be operative).

Should there be a risk of freezing, add anti-freeze: it is not advisable to empty the system as this may result in damage; use specific anti-freeze products suitable for multi-metal heating systems.

N.B.**IF YOU SMELL GAS:**

- do not turn on or off electrical switches and do not turn on electrical appliances;
- do not ignite flames and do not smoke;
- close the main gas tap;
- open doors and windows;
- **contact a Service Centre, qualified installer or the gas supply company.**

Never use flames to detect gas leaks.

WARNING

This boiler has been built for installation in the country indicated on the technical data plate: **installation in any other country may be a source of danger for people, animals and property.**

Read the warranty conditions and clauses on the warranty certificate attached to the boiler with care.

“WATER TREATMENT IN C.H. SYSTEM FOR CIVIL USE”**NOTE FOR INSTALLER AND USER**

- 1) The frequency of the cleaning of the D.H.W. heat exchanger is related to the hardness of the feeding water.
 - 2) With a water hardness higher than 14°f the use of antiscaling devices, whose choice will be made on the base of water characteristics, is suggested.
 - 3) To increase the resistance to the scaling, a D.H.W. temperature adjustment very close to that one of the actual use, is suggested.
 - 4) The adoption of a modulating room thermostat reduces the scaling danger.
 - 5) We advise you to verify the state of cleanness of the D.H.W. heat exchanger at the end of the first year and subsequently every two years.
-

REMEMBER:

- Periodically check the water pressure into the boiler.
- Ascertain to be able to turn OFF the appliance in case of emergency (power, gas and water supply).
- Make sure to be familiar with the switching ON and OFF and with the temperature adjusting knobs.
- The user is not allowed to remove the casing and get access to the internal parts of the boiler.
- Don't hang dresses,etc. to the boiler.
- Don't forget to plan the annual maintenance

INFORMATION FOR YOUR SAFETY

- **GAS LEAK**
Don't switch on the appliance if there is a suspicion of gas leak.
Contact IMMEDIATELY the technical personnel.
DON'T SEEK GAS LEAKS WITH NAKED FLAMES!!
- **LACK OF WATER**
If the pressure decreases repeatedly below the minimum operational pressure it means that there is a lack of water in the heating circuit. Contact the technical personnel for an inspection to the system.
- **LOCKOUT** 
The function of this symbol is to indicate that the burner is in lockout position, due to a lack of gas (check if the gas cock is open) or to a non detected ignition.

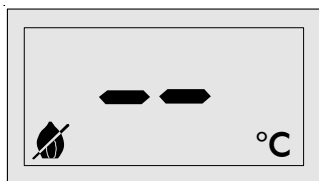
Display**Reset push button**

To put again the boiler in operation, it will be necessary to press the button.

In case the boiler goes frequently into lockout position, contact the service technician.

GAS VALVE LABEL



Per collegare l'attacco GAS della caldaia alla tubazione d'alimentazione, **E' OBBLIGATORIO** interporre una guarnizione A BATTUTA di misura e materiale adeguati. **NON È IDONEO** l'uso di canapa, nastro in teflon e simili.

While connecting gas inlet pipe of the boiler to the pipe coming from gas network, it is **MANDATORY** to insert a **TIGHT GASKET**, whose dimensions and material must be adequate. Connection is **NOT** suitable for hemp, teflon strip or similar materials

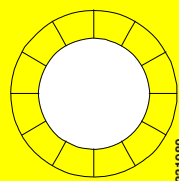

0033 1980

CONTROLS

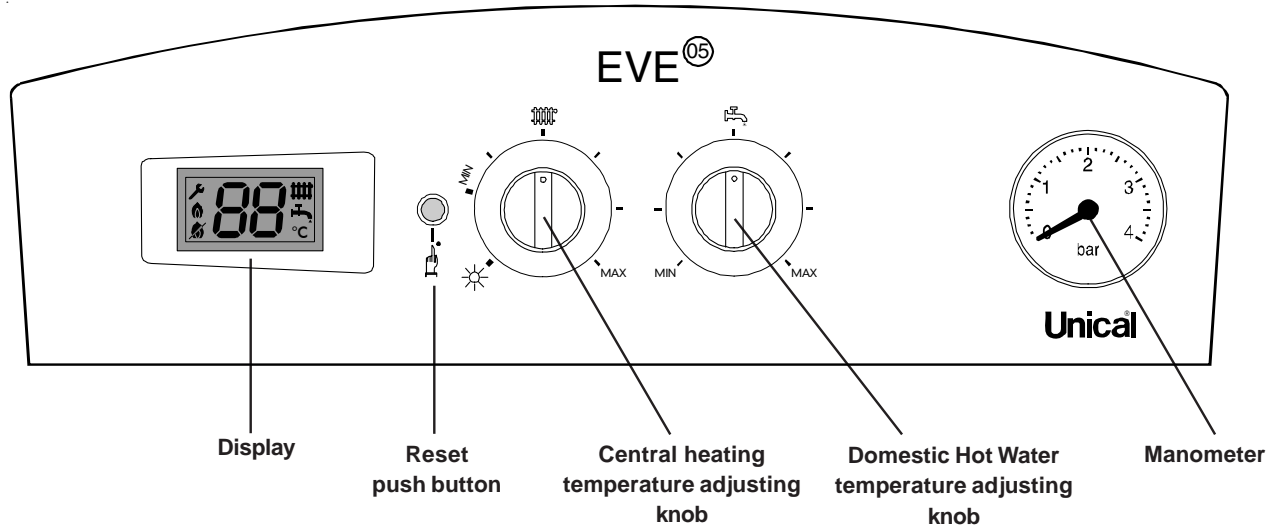

HOW TO START THE BOILER

- Switch ON the boiler through the external switch.
- Check if a room thermostat or a chronothermostat is fitted and set it on heat request.

Winter operation

(Central Heating + Domestic Hot Water) for **C** models
 (Central Heating only) for **R** models

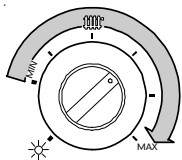

Set the Central Heating temperature knob into the range shown in the figure

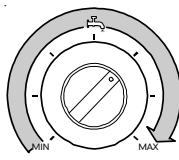

Set the Domestic Hot Water temperature knob into the range shown in the figure

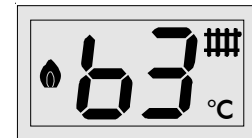

The display indicates that the boiler is in Central Heating mode and the flow temperature is 63°C.

Summer operation

(Domestic Hot Water only) for models **C**

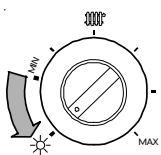

Set the Central Heating temperature knob to the symbol

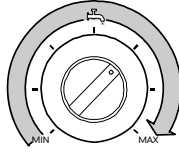

Set the Domestic Hot Water temperature knob into the range shown in the figure

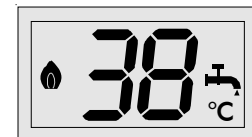

The display indicates that the boiler is in Domestic Hot Water mode and the water temperature is 38°C.

HOW TO ADJUST THE BOILER

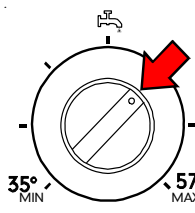
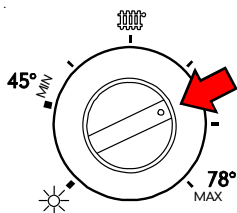

By adjusting the Domestic Hot Water temperature to the real required temperature, you will avoid to mix hot water with cold water, in this way reducing both the boiler operation costs and the scaling formation.

HOW TO SET THE WATER PRESSURE INTO THE SYSTEM

The water pressure into the system has to be checked periodically, in order to be sure of the boiler correct operation. The manometer arrow has to be above 0.8/1 bar when the boiler is switched off or in stand-by position. The boiler lock-out due to lack of water is displayed with the failure code **LP** (low Pressure). In order to see this code, once the boiler is in lock-out and the symbol  appears, push the reset push-button.

In order to increase the water pressure into the system, open the filling valve (black) under the boiler; when the pressure indicated on the manometer is between 0.8 and 1 bar, close the filling valve.

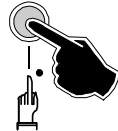
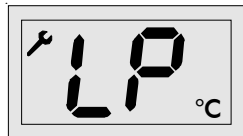

Standard position during operation



Position during water pressure setting

HOW TO SWITCH-OFF THE BOILER

For short periods: Rotate the knob "B" in position 
For long periods: Cut off the electrical and gas supply.

ANTIFROST PROTECTION

The boiler is equipped with an antifrost system that operates automatically when the boiler water temperature decreases under 6°C: the burner and the pump are automatically put into operation until the Central Heating system water temperature reaches 16°C. **This protection is active only if the boiler is electrically fed.**

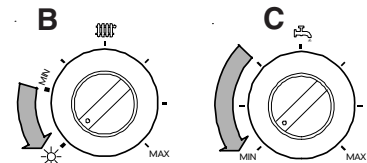

Set the Central Heating and Domestic Hot Water temperature knobs to the symbol shown in the figure. For R version boilers only knob B is there.

CLEANING

For the simple cleaning use a dry cloth. To remove hard blots, clean with a wet cloth and wipe with a dry cloth. **DO NOT USE abrasive products.**

DATA PLATE

CE Marking

- The CE marking documents that the boilers satisfy:
- The essential requirements of the Directive regarding gas appliances (Directive 90/396/CEE)

- The essential requirements of the Directive regarding electromagnetic compatibility (Directive 89/336/CEE)
- The essential requirements of the Efficiency Directive (Directive 92/42/CEE)
- The essential requirements of the low voltage Directive (Directive 73/23/CEE)

Unical CE 1

2

Mode1 3 CEE 92/42 ★ 4

S.N° 5 PIN 6

Types 7 NOx 8

A **Central Heating**

Pn 9 kW Pcond 10 kW

Qmax 11 kW Adjusted Qn 12 kW

PMS 13 bar T max 14 °C

B **Domestic hot water**

Qnw 15 kW D 16 l/min

R factor 17 F factor 18

PMW 19 bar T max 20 °C

C **Electrical Power supply**

21 V Hz 22 W

IP class: 23

E **Factory setting**

27

mbar

mbar

mbar

mbar

mbar

mbar

mbar

mbar

D **Countries of destination**

24 25 26

28

LEGEND:

- | | |
|--|--|
| 1 = CE Surveillance notify body | 17 = (R factor) N° taps based on the quantity of water declared EN 13203-1 |
| 2 = Boiler type | 18 = (F factor) N°stars based on the quality of water declared EN 13203-1 |
| 3 = Boiler model | 19 = (PMW) Max. pressure D.H.W. system |
| 4 = Number of stars (Directive 92/42/CEE) | 20 = (T max) Max. temperature D.H.W system |
| 5 = (S.N°) Serial number | C = Electrical features |
| 6 = P.I.N. code | 21 = Electrical power supply |
| 7 = Approved fluing configurations | 22 = Consumption |
| 8 = (NOx) NOx class | 23 = Protection grade |
| A = Central Heating circuit features | D = Countries of destination |
| 9 = (Pn) Nominal output | 24 = Direct and indirect country of destination |
| 10 = (Pcond) Condensing nominal output | 25 = Gas family |
| 11 = (Qmax) Nominal heat input | 26 = Supply pressure |
| 12 = (Adjusted Qn) Adjusted for nominal Heat input | E = Factory setting |
| 13 = (PMS) Max. pressure C.H. system | 27 = Adjusted for gas type X |
| 14 = (T max) Max. C.H. temperature | 28 = Space for national brands |

For your own safety, observe these safety instructions.:

**WARNING**

Identifies potentially dangerous situations.

**WARNING**

from risk of electric shock.

**PLEASE NOTE:**

User tip for the optimum utilisation and setting of the control(s) plus useful information.

User easy guide pag. 4-6

1

TECHNICAL FEATURES AND DIMENSIONS

1.1	Technical features	pag.	8
1.2	Dimensions	pag.	8
1.3	Hydraulic circuits	pag.	9
1.4	Technical data	pag.	12
1.5	Main characteristics	pag.	12

2

DIRECTIONS FOR INSTALLERS

2.1	Installations rules	pag.	13
2.2	Installation	pag.	13
2.2.1	Packing	pag.	13
2.2.2	Positioning the boiler	pag.	14
2.2.3	Assembling the boiler	pag.	15
2.2.4	Ventilation	pag.	15
2.2.5	Flue gas discharge system	pag.	15
2.2.6	Discharge and suction pipe configuration	pag.	17
2.2.7	Positioning of terminals for type C boilers	pag.	18
2.2.8	Smoke evacuation Ø80 air suction flange	pag.	19
2.2.9	Discharge of flue gas into coaxial ducts with a diameter of 100/60 mm (Type A accessories)	pag.	20
2.2.10	Flue gas discharge and air suction with separate pipes with 80 mm diameter	pag.	21
2.2.11	Measurements of combustion efficiency	pag.	23
2.2.12	Connection to the gas mains	pag.	24
2.2.13	Hydraulic connection	pag.	24
2.2.14	Electrical connection	pag.	26
2.2.15	Jumper location	pag.	26
2.3	Wiring diagram	pag.	27
2.3.1	Practical connection diagram	pag.	27
2.4	Filling the system	pag.	28
2.5	Starting the boiler	pag.	28
2.6	Adjusting the burner	pag.	29
2.7	Modification of other gases	pag.	30
2.8	Failure code	pag.	31

3

USERS' INSTRUCTION

3.1	Control panel	pag.	33
3.2	Switching on/off	pag.	34
3.3	Antifrost protection	pag.	35
3.4	Important suggestion and notes	pag.	35

1 TECHNICAL FEATURES AND DIMENSIONS

1.1 - TECHNICAL FEATURES

EVE 05 is a wall hung gas boiler with built-in atmospheric gas burner; it is available in the following versions:

- 24** with 24 kW output;
- C** with instantaneous D.H.W. production;
- R** for heating only;
- TN** with natural draught open chamber;
- TFS** with forced draught room sealed combustion chamber;

All versions have electronic ignition. Models in the **EVE 05** series are the following:

EVE 05 CTN 24 F open boiler, with electronic ignition and instantaneous D.H.W. production;

EVE 05 RTN 24 open boiler, with electronic ignition, for heating only;

EVE 05 CTFS 24 F forced draught room sealed boiler, with electronic ignition and instantaneous D.H.W. production;

EVE 05 RTFS 24 forced draught room sealed boiler, with electronic ignition for heating only;

EVE 05 CTN 24 open boiler, with electronic ignition and instantaneous D.H.W. production with DHW plates heat exchanger

EVE 05 CTFS 24 forced draught room sealed boiler with electronic ignition and instantaneous D.H.W production with DHW plates heat exchanger

EVE 05 is supplied with all control and safety devices according to the latest laws in force.

The main technical features of the **EVE 05** boilers are summarised below.

- Bithermal, copper, high performance heat exchanger (CTN 24F - CTFS24F);
- Plates heat exchanger for the DHW production (CTN 24 – CTFS 24)
- Electronic ignition;
- Electronic flame modulation;
- Minimum output control;
- Electronic control of ignition ramp;
- Anti-freeze function;

- Pump anti-jamming function;
- Pump over run function;
- High limit thermostat (95°C);
- Three-speed circulating pump;
- Expansion vessel;
- Automatic air vent;
- C.H. system water filling valve;
- Safety pressure switch for low water level;
- Priority flow switch for D.H.W.;
- Tap water flow rate restrictor set at 12 litres/min.
- Control panel with IP X4D insulation protection
- Manometer;
- Warning light for: presence of power, request for heating, burner in operation, lock out, by the display
- D.H.W. temperature selector (35/57°C) for EVE 05 CTN 24 F - CTFS 24 F - CTFS 24 CTN 24 ;
- C.H. temperature selector (45/78°C) + summer/winter position.
- Reset push button / Chimney sweeper button / Error codes visualization / Thermometer
- Paper mounting jig for connections pre-disposition
- Mounting jig opt.
- Flue gas antispillage thermostat (EVE 05 TN)

1.2 - DIMENSIONS

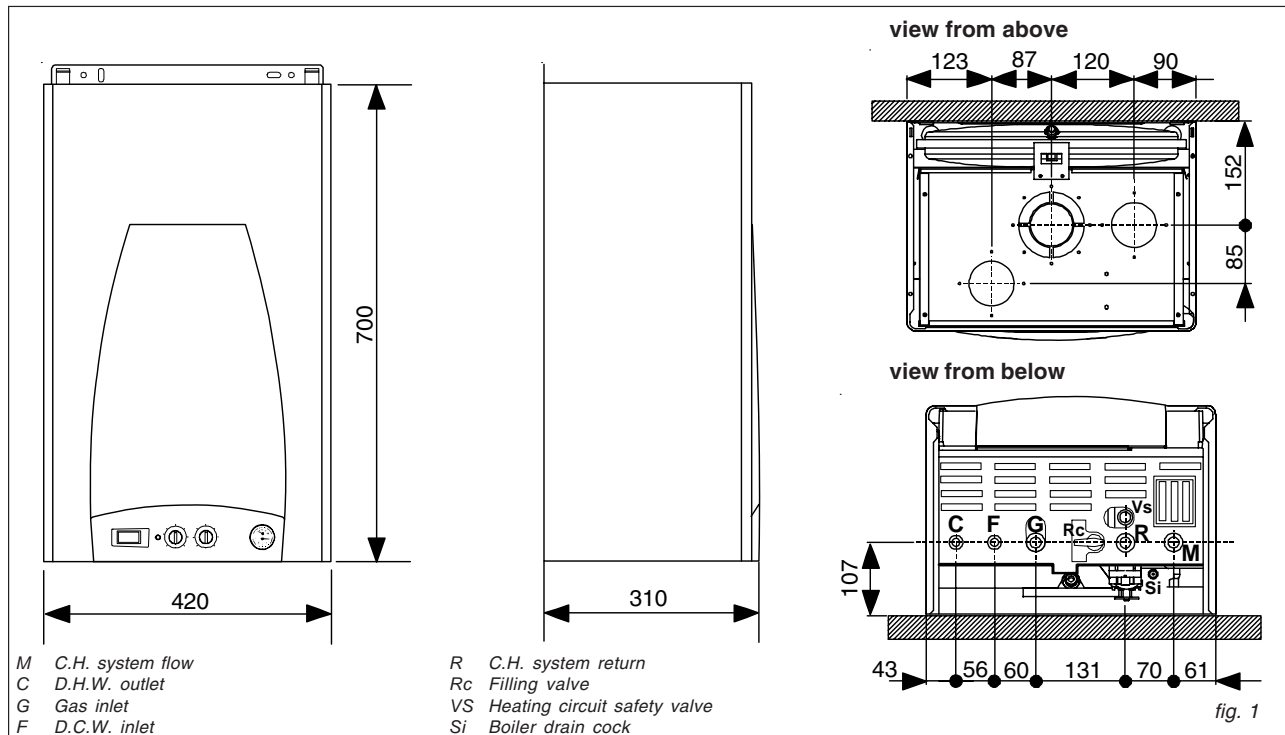
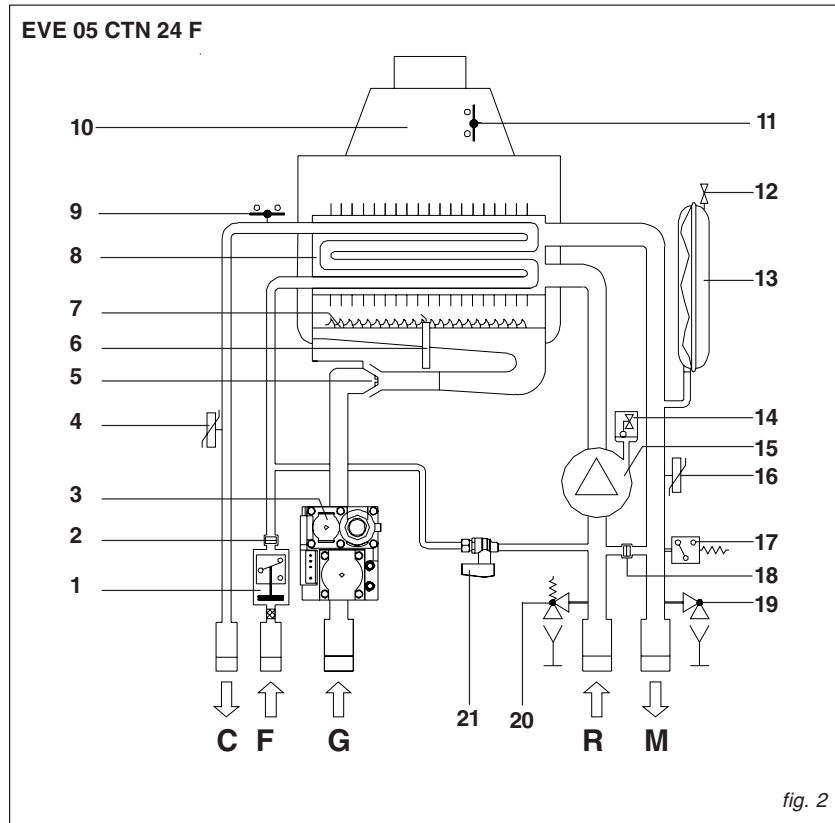
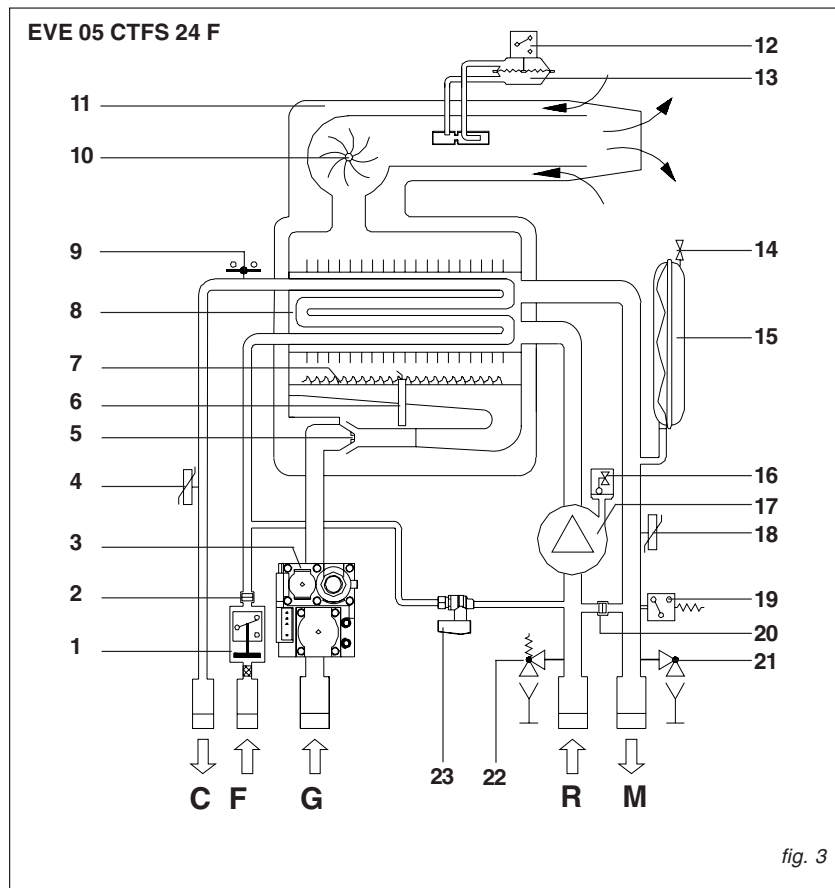

fig. 1

1.3 - HYDRAULIC CIRCUIT



- 1 Flow switch - Cold water filter
 - 2 D.H.W. flow restrictor
 - 3 Gas valve
 - 4 D.H.W. temperature sensor
 - 5 Burner nozzles
 - 6 Ionisation/Ignition electrode
 - 7 Burner
 - 8 Bithermal heat exchanger
 - 9 H.L. thermostat
 - 10 Flue gas manifold/down-draught diverter
 - 11 Flue gas anti-spillage thermostat
 - 12 Expansion vessel inflating valve
 - 13 Expansion vessel
 - 14 Automatic air vent
 - 15 Circulating pump
 - 16 C.H. temperature sensor
 - 17 Minimum water pressure switch
 - 18 By-pass (unadjustable)
 - 19 Boiler drain cock
 - 20 Heating circuit safety valve
 - 21 Filling valve
- C D.H.W. outlet
 F D.C.W. inlet
 G Gas inlet
 R C.H. system return
 M C.H. system flow



- 1 Flow switch - Cold water filter
 - 2 D.H.W. flow restrictor
 - 3 Gas valve
 - 4 D.H.W. temperature sensor
 - 5 Burner nozzles
 - 6 Ionisation/Ignition electrode
 - 7 Burner
 - 8 Bithermal heat exchanger
 - 9 H.L. thermostat
 - 10 Flue gas extractor fan
 - 11 Air/flue coaxial duct
 - 12 Micro-switch on flue gas pressure switch
 - 13 Flue gas pressure switch
 - 14 Expansion vessel inflating valve
 - 15 Expansion vessel
 - 16 Automatic air vent
 - 17 Circulating pump
 - 18 C.H. temperature sensor
 - 19 Minimum water pressure switch
 - 20 By-pass (unadjustable)
 - 21 Boiler drain cock
 - 22 Heating circuit safety valve
 - 23 Filling valve
- C D.H.W. outlet
 F D.C.W. inlet
 G Gas inlet
 R C.H. system return
 M C.H. system flow

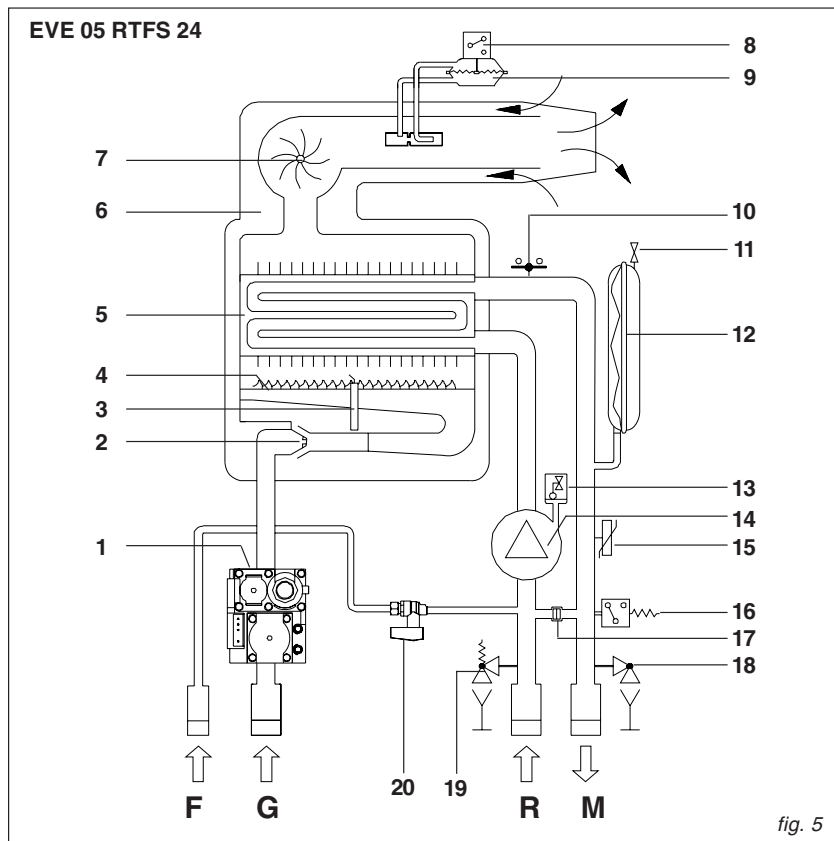
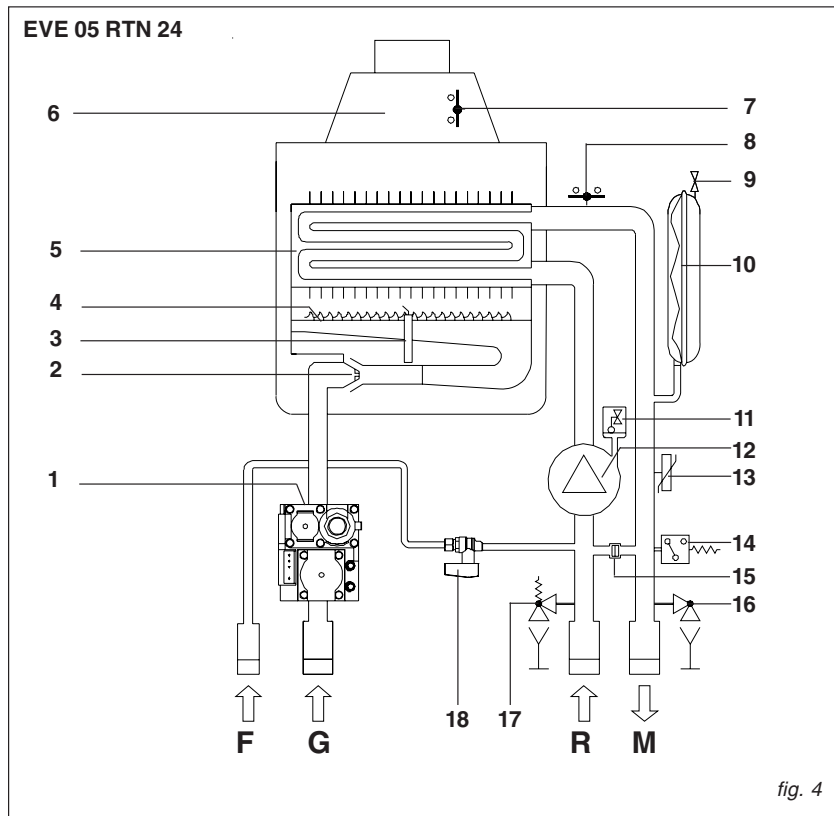

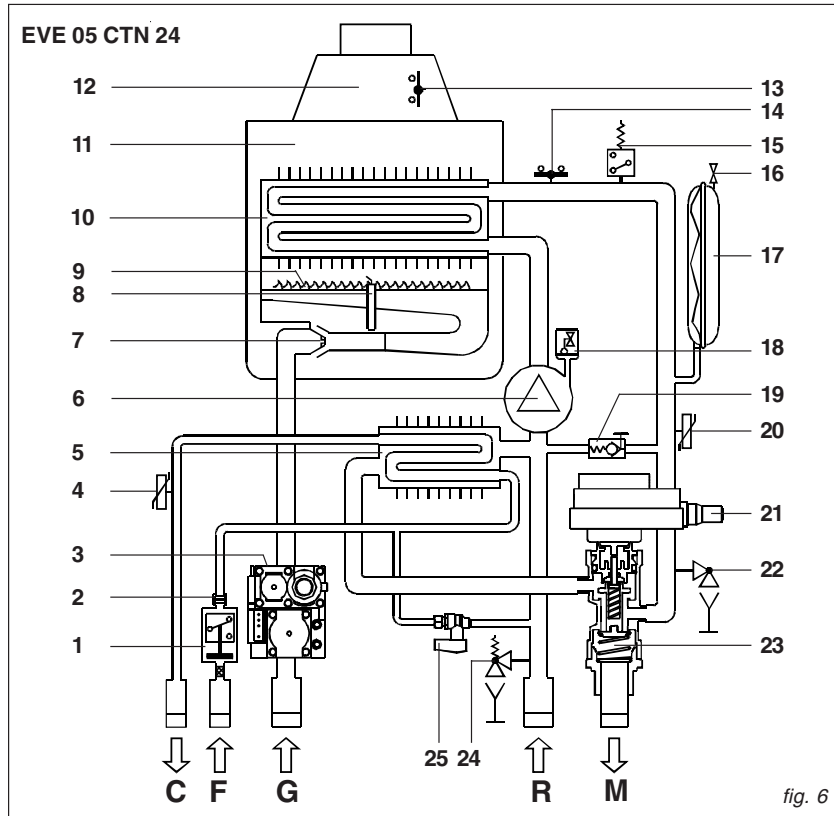

- 1 Flow switch - Cold water filter
 - 2 D.H.W. flow restrictor
 - 3 Gas valve
 - 4 D.H.W. temperature sensor
 - 5 Plates heat exchanger for DHW production
 - 6 Circulating pump
 - 7 Burner nozzles
 - 8 Ionisation/Ignition electrode
 - 9 Burner
 - 10 Monothermal heat exchanger
 - 11 Combustion chamber
 - 12 Flue gas manifold/down-draught diverter
 - 13 Flue gas anti-spillage thermostat
 - 14 H.L. thermostat
 - 16 Expansion vessel inflating valve
 - 17 Expansion vessel
 - 18 Automatic air vent
 - 19 By-pass
 - 20 C.H. temperature sensor
 - 21 Diverting valve motor
 - 22 Boiler drain cock
 - 23 Diverting valve
 - 24 Heating circuit safety valve
 - 25 Filling valve
- C D.H.W. outlet
 F D.C.W. inlet
 G Gas inlet
 R C.H. system return
 M C.H. system flow

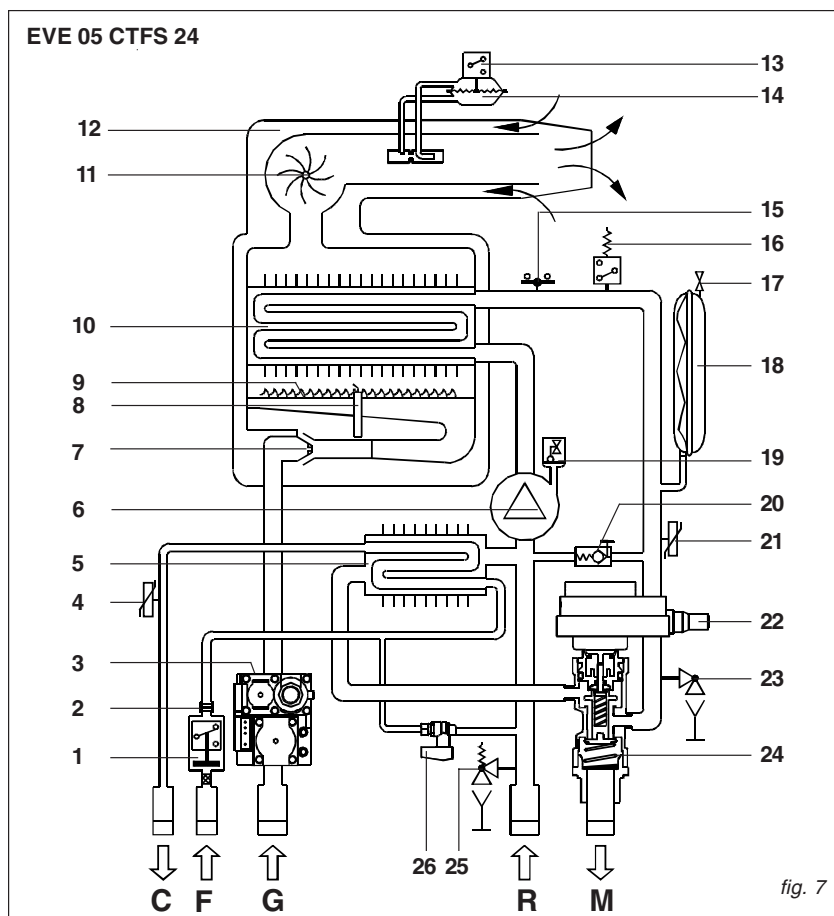

- 1 Flow switch - Cold water filter
 - 2 D.H.W. flow restrictor
 - 3 Gas valve
 - 4 D.H.W. temperature sensor
 - 5 Plates heat exchanger for DHW production
 - 6 Circulating pump
 - 7 Burner nozzles
 - 8 Ionisation/Ignition electrode
 - 9 Burner
 - 10 Monothermal heat exchanger
 - 11 Flue gas extractor fan
 - 12 Air/flue coaxial duct
 - 13 Micro-switch on flue gas pressure switch
 - 14 Flue gas pressure switch
 - 15 H.L. thermostat
 - 16 Minimum water pressure switch
 - 17 Expansion vessel inflating valve
 - 18 Expansion vessel
 - 19 Automatic air vent
 - 20 By-pass
 - 21 C.H. temperature sensor
 - 22 Diverting valve motor
 - 23 Boiler drain cock
 - 24 Diverting valve
 - 25 Heating circuit safety valve
 - 26 Filling valve
- C D.H.W. outlet
 F D.C.W. inlet
 G Gas inlet
 R C.H. system return
 M C.H. system flow

1.4 - OPERATING DATA

For the following data: Nozzle - Burner pressure - Diaphragm (where applicable) - Inputs - Gas consumptions refer to pagraph SUITABILITY TO USE OTHER GASES.

	EVE 05	RTN 24	CTN 24 F	RTFS 24	CTFS 24 F	CTN 24	CTFS 24
Nominal output	kW	24	24	24,2	24,2	24	24,2
Minimum output	kW	10,17	10,17	9,9	9,9	10,17	9,9
Actual water efficiency at full load (100%)	%	90,57	90,57	91,34	91,34	90,57	91,34
Min. required water efficiency at full load (100%)	%	89,76	89,76	89,77	89,77	89,76	89,77
Actual water efficiency at part load (30%)	%	92,60	92,60	89,93	89,93	92,60	89,93
Min. required water efficiency at part load (30%)	%	87,14	87,14	87,15	87,15	87,14	87,15
Stars No. off (According EEC Directive 92/42)	n.	2	2	2	2	2	2
Combustion efficiency at nominal load (100%)	%	92,85	92,85	92,71	92,71	92,85	92,71
Combustion efficiency at part load (30%)	%	90,83	90,83	87,81	87,81	90,83	87,81
Stand-by losses (min.-max.)	%	2,38 - 2,28	2,38 - 2,28	1,7-1,37	1,7-1,37	2,38-2,28	1,7-1,37
(*)Flue gas temperature (min. - max.)	°C	86,7	86,7	116,7	116,7	86,7	116,7
Flue gas mass flow rate (min. - max)	g/s	14,11-20,03	14,11-20,03	13,41-15,1	13,41-15,1	14,11-20,03	13,41-15,1
Excess of air l	%	117,89	117,89	60,86	60,86	117,89	60,86
CO ₂	%	2,9-5,1	2,9-5,1	3,0-7,0	3,0-7,0	2,9-5,1	3,0-7,0
NO _x (value according EN 297/A3 + EN 483)	mg/kWh	152,4	152,4	184,4	184,4	152,4	184,4
NO _x class		2	2	2	2	2	2
Flue losses with burner in operation (min.-max)	%	9,17 - 7,15	9,17 - 7,15	12,19-7,29	12,19-7,29	9,17-7,15	12,19-7,29
Flue losses with burner off	%	0,831	0,831	0,405	0,405	0,831	0,405

1.5 - GENERAL FEATURES

		RTN 24	CTN 24 F	RTFS 24	CTFS 24 F	CTN 24	CTFS 24
Appliance category		II _{2H3P}	II _{2H3P}	II _{2H3P}	II _{2H3P}	II _{2H3P}	II _{2H3P}
Min. water flow rate in CH circuit (Dt 20 K)	l/min	7,3	7,3	7,10	7,10	7,3	7,10
Min. pressure in CH circuit	bar	0,7	0,7	0,7	0,7	0,7	0,7
Max. pressure in CH circuit	bar	3	3	3	3	3	3
Water content primary circuit	l	3,5	3,5	3,5	3,5	3,5	3,5
Max. oper. temperature in CH mode	°C	78	78	78	78	78	78
Min. oper. temperature in CH mode	°C	45	45	45	45	45	45
Total capacity of expansion vessel	l	6	6	6	6	6	6
C.H. expansion vessel pre-loading	bar	1	1	1	1	1	1
Max. water content CH circuit (calc. x max. T° of 82°C)	l	137,9	137,9	137,9	137,9	137,9	137,9
Min. water flow rate in D.H.W. circuit	l	-	2,5	-	2,5	2,5	2,5
Min. DHW. pressure	bar	-	0,5	-	0,5	0,5	0,5
Max. DHW. pressure	bar	-	6	-	6	6	6
DHW specific flow rate (Δt 30 K)	l/min.	-	11,5	-	11,5	11,5	11,5
Flow restrictor	l/min.	-	12	-	12	12	12
DHW production in continuous operation with Δt 45 K	l/min.	-	7,6	-	7,6	7,6	7,6
DHW production in continuous operation with Δt 40 K	l/min.	-	8,6	-	8,6	8,6	8,6
DHW production in continuous operation with Δt 35 K	l/min.	-	9,8	-	9,8	9,8	9,8
DHW production in continuous operation with Δt 30 K	l/min.	-	11,4	-	11,4	11,4	11,4
DHW production in continuous operation with Δt 25 K*	l/min.	-	13,7	-	13,7	13,7	13,7
DHW Temperature range	°C		35 - 57		35 - 57	35 - 57	35 - 57
Electrical supply	V-Hz	230/50	230/50	230/50	230/50	230/50	230/50
Supply fuse	A (F)	3,15	3,15	3,15	3,15	3,15	3,15
Maximun absorbed power	W	96	96	130	130	98	132
Insulation protection	IP	X4D	X4D	X4D	X4D	X4D	X4D
Net weight	kg	28	30	34,5	36,5	32	38,5
Gross weight		31	33	37,5	39,5	35	41,5

(*) mixed



Warning: If the boilers are used in low temperature heating system (ex. floor heating)

it is necessary to use a mixing valve to avoid condensation phenomena.

2

DIRECTIONS FOR INSTALLER

2.1 - DIRECTIONS FOR INSTALLER

EVE 05 is a gas boiler which must be installed in accordance with the latest regulations or rules in force. For the boiler category, which changes according to the destination country, see page 6.

NOTE:

Observe the corresponding technical rules and the building supervisory and statutory regulations of the country of final use when installing and operating the system.

Always ensure that an appropriately specialised company is entrusted with installation, gas supply and flue gas connection, commissioning and power supply connection, as well as all servicing and repair work.

Work on gas conduits and fittings must only be carried out by a registered service provider. The system must be cleaned and serviced once a year. This includes an inspection of the entire system to see if it is in full working order. Defects and faults must be eliminated

immediately.

Please note that we can accept no liability whatsoever for loss or injury resulting from unauthorised adjustment or manipulation of the system's control or regulating devices.

2.2 - INSTALLATION

2.2.1 - PACKING

EVE 05 is delivered completely assembled and packed in a strong cardboard box. Once the boiler has been unpacked check that it is intact.



Keep the packaging material (cardboard box, plastic strips, plastic bag, etc.) out of the reach of children as it represents a choking and suffocation hazard.



UNICAL refuses all liability for injury to persons and animals or damage to property resulting from non-observance of the above.

In addition to the boiler packaging contains:

- a bag with:
- installation, use and maintenance handbook,
- template for fixing the boiler to the wall,

A bag containing:

- 2 dowels with screws hook to fix the boiler to the wall,
- Only for models **TFS**, a diaphragm for flue gas outlet

Only for the **TFS** (room sealed fan assisted) models a bag containing:

- 2 sealed room closing covers + 2 sealing gaskets and the fixing screws. “

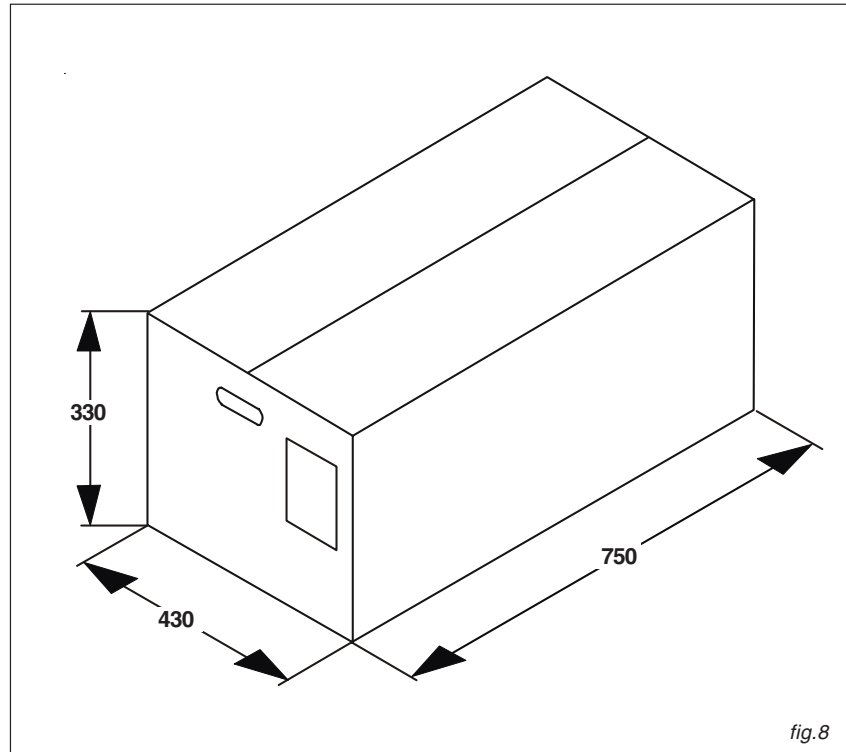

fig.8

2.2.2 - POSITIONING THE BOILER

Every boiler is supplied with special "MOUNTING JIG" with which the pipes for connection to the system, D.H.W. and gas can be positioned when the hydraulic system is being laid out and before the boiler is installed.

This MOUNTING JIG, comprising a sheet of strong paper which must be fixed to the wall chosen for the installation of the boiler, gives all the indications needed to make the holes in the wall using two screws with expanding dowels.

Use the lower part of the MOUNTING JIG to mark the exact point of the connection of the gas supply, cold water supply pipe, D.H.W. outlet, C.H. flow and return.

When choosing the position of the boiler:

- refer to the indications given in the section "Flue gas evacuation system".
- leave a clearance of 50 mm on each side of the boiler to facilitate maintenance operations.
- Leave a 200 mm free space under the boiler in order to allow the possible verification or substitution of the DHW plates heat exchanger.
- check that the wall is suitable.
- avoid fixing the boiler to thin partitions.
- avoid installing the boiler above appliances which might affect operation when in use (cookers which produce greasy steam, washing machines, etc.)
- avoid installing natural draught boilers in corrosive or very dusty atmospheres such as hairdressers', laundrettes, etc. as the life of the boiler components could be significantly shortened.



For EVE 05 TFS

Since the temperature of the wall on which the boiler is installed and the temperature on the surface of the coaxial duct do not increase, in normal operating conditions, more than 60 K, it is not necessary to keep a minimum distance from inflammable walls.

For boilers with dual suction and exhaust ducts, place insulating material between the wall and the pipe in the case of inflammable walls and wall crossings.



EVE 05 TN

Maintain distance of at least 200 mm on the sides with wall which have inflammable materials.

	Ø	L mm
M = C.H. system flow	= 3/4"	107
C = D.H.W. outlet	= 1/2"	107
G = Gas	= 3/4"	107
F = Cold water inlet	= 1/2"	107
R = C.H. system return	= 3/4"	107
Vs = Safety valve discharge	=	143
Si = Boiler drain cock	=	60

MOUNTING JIG FOR BOILER CONNECTIONS 00332145

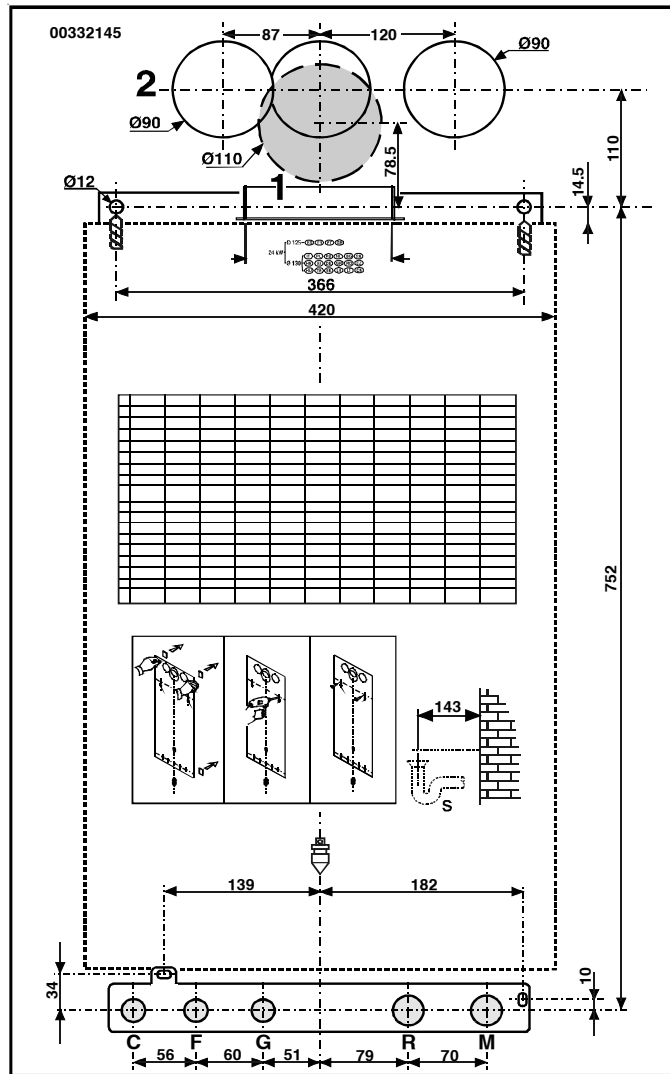

CONNECTION POSITION SEEN FROM BELOW

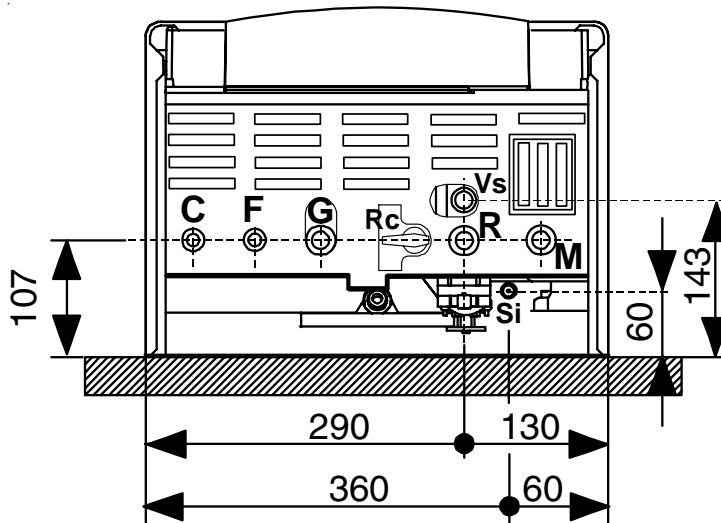

fig. 9

2.2.3 - ASSEMBLING THE BOILER

Before connecting the boiler to the D.H.W. and heating system pipes, carefully clean the pipes to remove all traces of metal resulting from processing and welding operations as well as any oil and grease which could damage the boiler or jeopardize its operation.



Unical refuses all liability for injury to persons and animals or damage to property resulting from non-observance of the above.



Do not use solvents which could damage the components.

- connect the boiler to the gas pipe, domestic cold and hot water pipes, CH flow and return pipes.
- connect to electrical supply

To install the boiler:

- Fix with tape the paper template to the wall;
- make two Ø 12 holes in the wall and insert the dowels;
- position the junction points for the connection of the gas supply pipe, cold water supply pipe, D.H.W. outlet, CH flow and return in the positions shown by the template. ;
- fit the boiler onto the support hooks;

2.2.4 - VENTILATION

The boiler must be installed in a suitable room according to the rules in force and particularly:

NATURAL DRAUGHT OPEN FLUE BOILERS (TYPE B11bs and VMC INSTALLATIONS)

The boilers **EVE 05 CTN 24 F, EVE 05 RTN 24, EVE 05 CTN 24**, are open flue boilers and are foreseen for chimney connection: the air for combustion is taken directly from the room in which the boiler is installed.

The room can have both a direct ventilation (i.e. with ventilation openings facing outwards) or an indirect ventilation (i.e. with ventilation openings facing an adjacent room) provided that the following requirements are complied with:

Direct ventilation:

- The room has to have a ventilation opening of, at least, 6 cm² /kW of installed input (see input table on par. 2.7) and, in no case, lower than 100 cm² and made directly onto an external wall.
- The opening has to be as close as possible to the floor.
- It should not be possible to close it and it should be protected with a grate not reducing its usefull ventilation section.
- A correct ventilation can be obtained also through the addition of more openings, provided the addition of the different sections is not less than that really needed.

- In case it is not possible to make a ventilation opening close to the floor, it will be necessary to increase its usefull section of at least 50%.
- If an open fire is present in the same room it needs an independent air supply, otherwise the installation of a type B appliance is not permitted.
- If in the room there are other devices which need air for their operation (e.g. a wall exhauster) the section of the ventilation opening has to be the properly sized.

Indirect ventilation

In case it is not possible to make a room ventilation opening on an external wall, it is possible to have an indirect ventilation, sucking the air from an adjacent room, making an opening in the lowest part of a door.

This solution is possible only if:

- The adjacent room is not a bed room
- The adjacent room is not a common part of the building and is not a room with fire danger (e.g. a fuel deposit, a garage, etc..)

FORCED DRAUGHT ROOM SEALED BOILER

(TYPE C12 - C32 - C42 - C52 - C62 - C82)

The **EVE 05 CTFS 24 F - EVE 05 RTFS 24 - EVE 05 CTFS 24** are forced draught, room sealed boilers; so they do not need particular ventilation openings for the combustion air, in the

room in which they are installed.

FORCED DRAUGHT, OPEN FLUE BOILER (TYPE B22)

If the **EVE 05 CTFS 24 F - EVE 05 RTFS 24 - EVE 05 CTFS 24** are installed in a room according to the chimney configuration on type **B22**, the same ventilation requirements established in paragraphs **Direct ventilation** and **Indirect ventilation** apply.

2.2.5 - FLUE GAS DISCHARGE SYSTEM

NATURAL DRAUGHT OPEN FLUE BOILERS

Connection to the chimney

A good chimney is very important for the correct functioning of the boiler; it must therefore conform with the following requirements:

- it must be made from waterproof material and be resistant at the temperature of the flue gas and relative condensate;

- it must have sufficient mechanical strength and low thermal conductivity;
- it must be perfectly sealed to prevent cooling due to parasite air inlets;
- it must be as vertical as possible and the end section must have a chimney cap which guarantees efficient and constant evacuation of the combustion products;
- the chimney must have a diameter not smaller than that of the boiler's draught diverter; for chimneys with a square or rectangular section, the internal section must be 10% larger than the section of the

- connection duct to the draught diverter.
- starting from the draught diverter, the duct must have a vertical section with a length more than twice the diameter, before getting into the chimney.

Direct emission into the atmosphere

Natural draught boilers can discharge combustion products directly into the atmosphere using a duct, which goes through the outside walls of the building, connected to a flue exhaust terminal.

The exhaust duct must also comply with the following requirements:

- the sub-horizontal part inside the building must be as short as possible (no more than 1 m);
- for boilers with vertical discharge, such as boilers **EVE 05 TN 24**, there must be no more than 2 direction changes;
- it must receive the discharge from a single boiler;
- the part going through the wall must be protected by a sheath duct; the part of the sheath duct facing the inside of the building must be sealed and the part facing outwards must be open;
- the final section, on which the draught terminal will be fixed, must protrude from the wall of the building for a length of at least twice the diameter of the duct;
- the draught terminal must overlap the connection to the boiler by at least 1.5 m (see fig. 8).

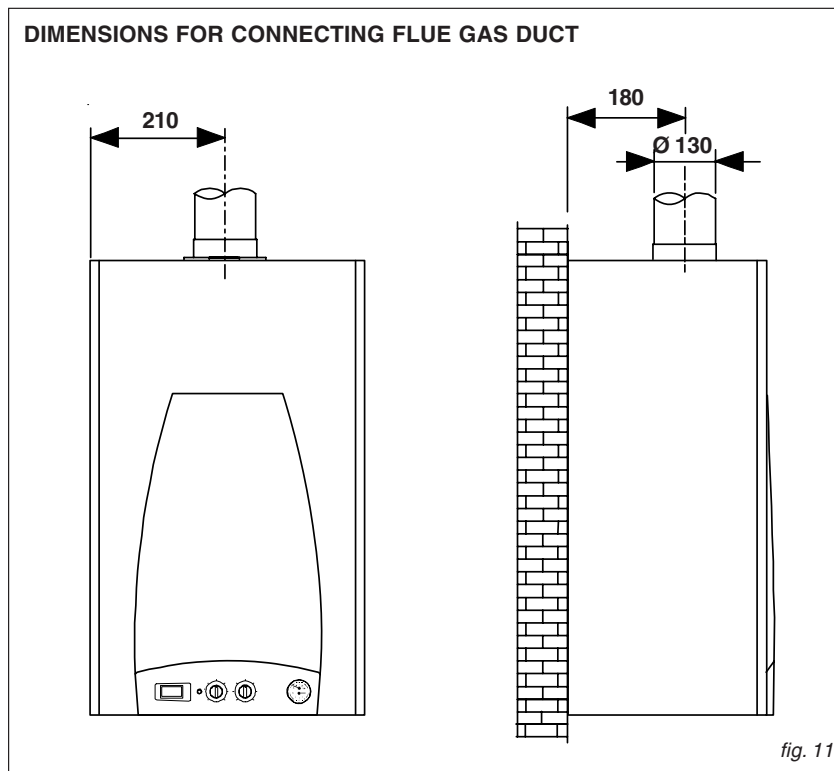
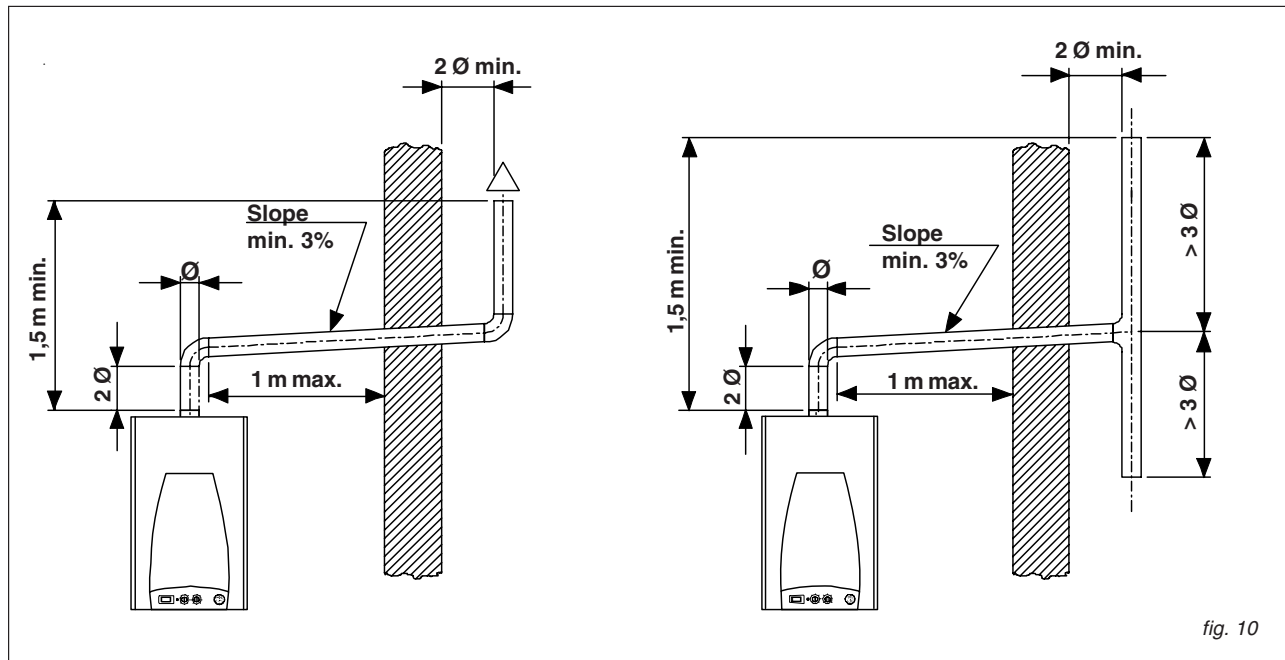

WARNING:

The boiler is fitted with an automatic safety reset device as protection against spillage of combustion products inside the building.

In case of the device operation, the boiler will remain in lock-out position indicating the anomaly on the display with the symbol "M" (fig. 35) (failure code **AF**)

After the cooling down of the smoke thermostat it will be possible to restart the boiler by pressing the reset button **L** fig. 35.



It is absolutely forbidden to by-pass the smoke thermostat.

If the boiler cuts off regularly, it is necessary to ask a technician for a check of the flue gas exhaust duct. This duct may be obstructed or may be unsuitable for the discharge of flue gas into the atmosphere.



UNICAL refuses all liability for damage caused as a result of incorrect installation, use, modification of the boilers or for non-observance of the instructions provided by the manufacturer or applicable installation regulations

2.2.6 - SMOKE DISCHARGE AND AIR SUCTION DUCT CONFIGURATION
C12, C32, C42, C52, C62, C82 - B22

C12 Boiler designed for connection to horizontal exhaust and suction terminals directly into the atmosphere using coaxial or dual ducts. The distance between the air intake duct and the flue gas outlet duct must be at least 250 mm and both end sections must be located within a 500 mm square.

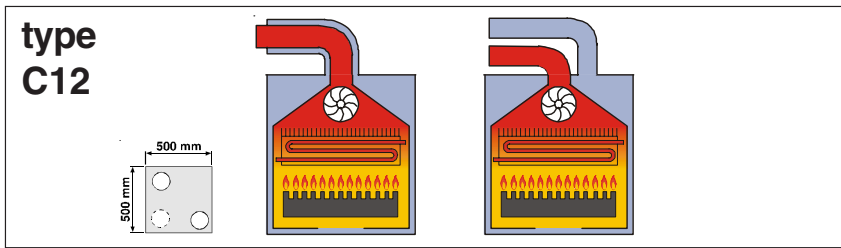

C32 Boiler designed for connection to vertical discharge and suction outlets directly into the atmosphere using coaxial or dual ducts. The distance between the air intake duct and the flue gas outlet duct must be at least 250 mm and both end sections must be located within a 500 mm square.

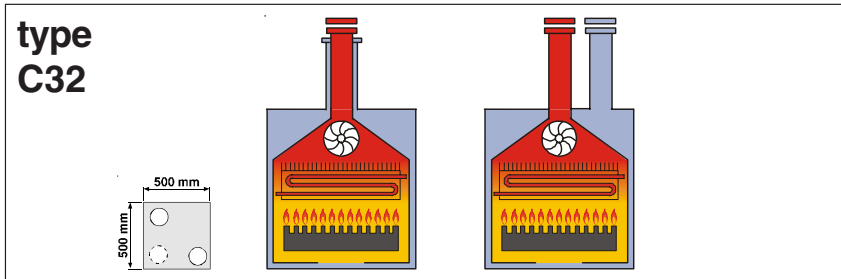

C42 Boiler designed for connection to collective chimneys including two ducts, one for the suction of combustion air and the other for the exhaust of the combustion products, through coaxial or dual ducts.

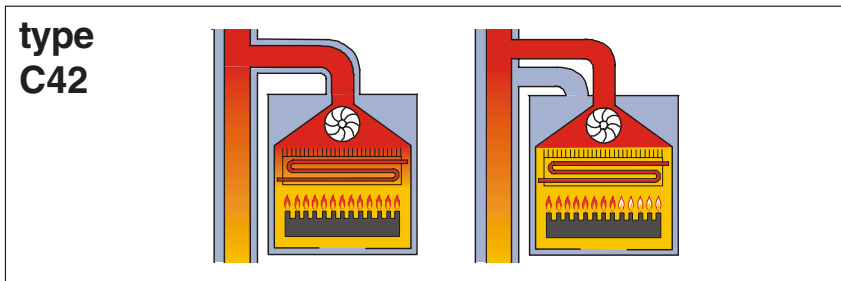

The chimney must comply with relevant applicable law provisions.

C52 Boiler with separate combustion air suction and combustion product exhaust ducts. **These ducts can discharge into areas with different pressure. The dual ducts must not be located on two opposite walls.**

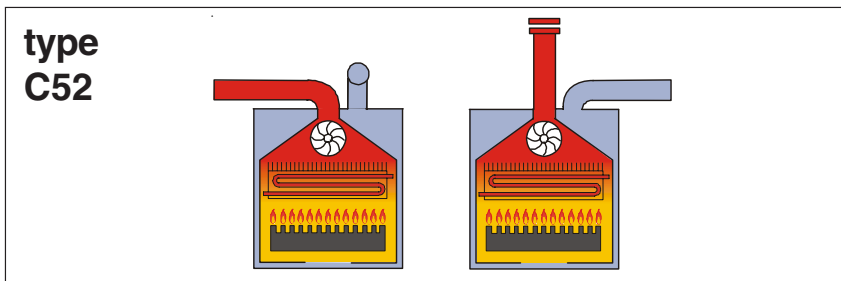

C62 Boiler that has to be connected to a system of air supply and smoke of approved type and sold apart.

C82 Boiler designed for connection to an air supply terminal and fitted to an individual or shared chimney.

The chimney must comply with relevant applicable law provisions.

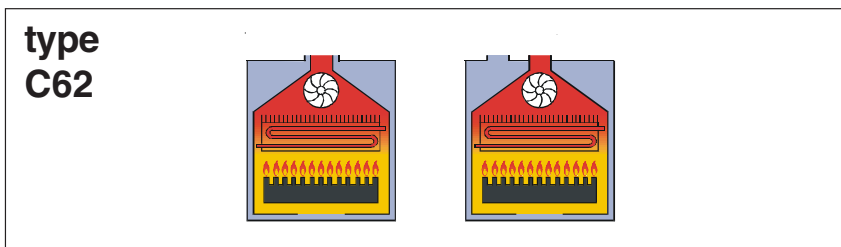

B22 Boiler designed for connection to an external flue gas evacuation duct, with the air for combustion taken from the room in which the boiler is installed. For this type of installation the boiler house follows the same installation requirements used for the open type boilers.

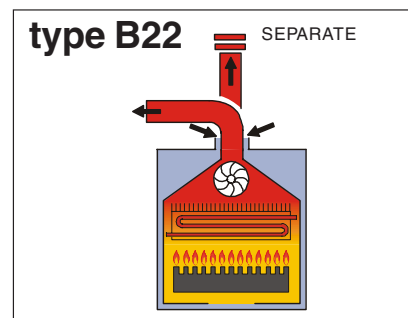
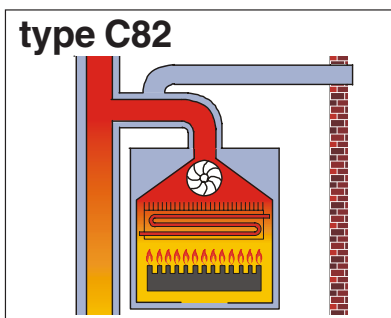

2.2.7 - POSITIONING OF TERMINALS FOR TYPE "C" BOILERS

either take place through the roof or directly outwards the room they are installed in. The following distances shall be considered for terminals proper positioning:

Pursuant to the directives of regulations in force, discharge of forced draught boilers can

POSITIONING OF TERMINALS FOR "FORCED DRAUGHT" BOILERS		
POSITIONING OF THE TERMINAL		Min. distances in mm.
Under a window	A	600
Under a ventilation opening	B	600
Under a gutter	C	300
Under a balcony (1)	D	300
From an adjacent window	E	400
From an adjacent ventilation opening	F	600
From vertical or horizontal air pipes or drains (2)	G	300
From an external corner of the building	H	300
From an internal corner of the building	I	300
From the ground or from another floor	L	2500
Between two vertical terminals	M	1500
Between two horizontal terminals	N	1000
From a facing front surface without opening or terminals within a radius of 3 mt. from smoke outlet point	O	2000
As above, but with openings or terminals within a radius of 3 mt. from smoke outlet point	P	3000

NOTES

- (1) Terminals below a practicable balcony shall be arranged in such a way as to assure that the total run of smokes, from their outlet from terminal up to outlet from balcony external perimeter, including the height of protection baluster, if any, is not less than 2 m.
- (2) Distances of not less than 500 mm shall be adopted in placing the terminals, due to the proximity to materials subject to the action of products of combustion such as plastic gutters or waterspouts, wooden jetties, etc.) unless adequate screening measures are taken for the said materials.

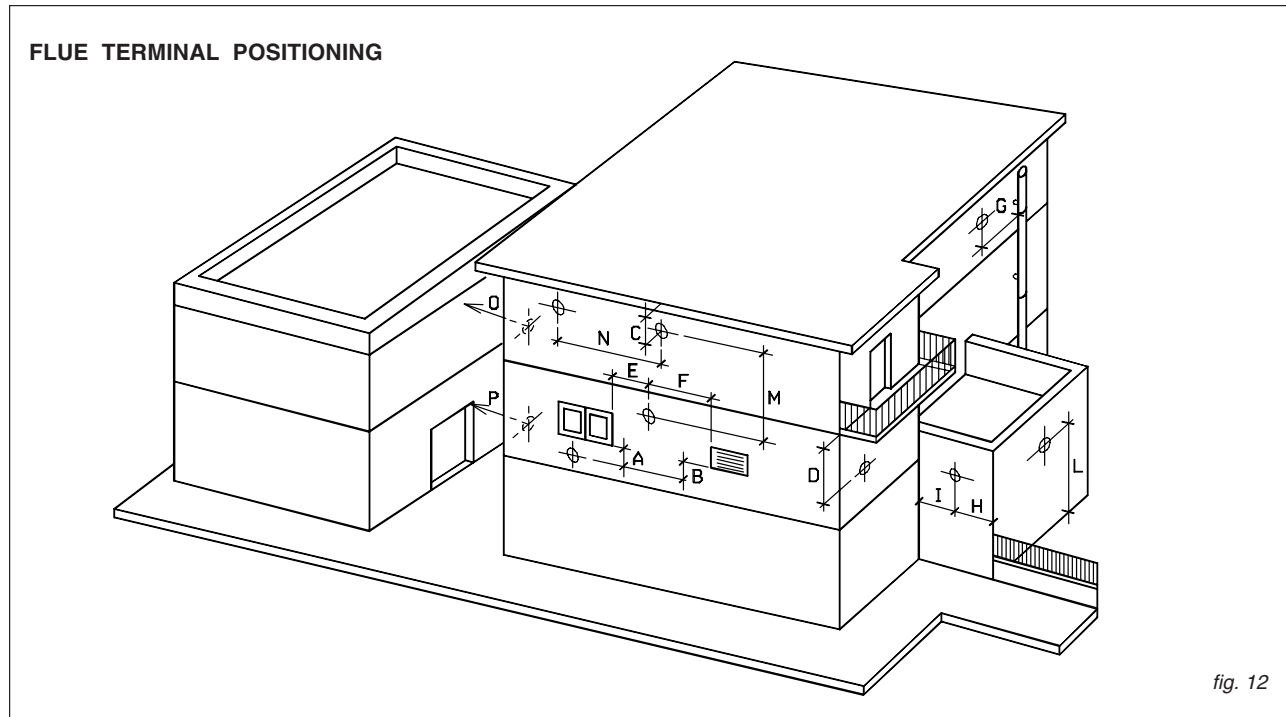

fig. 12

2.2.8 - SMOKE EVACUATION Ø 80 WITH AIR SUCTION FLANGE - Type B22 (see par. 2.2.6)

Note: For evacuation system with 80 mm dia. and a length between 0.5 m and 4 m, it is necessary to introduce a diaphragm of 42 mm dia. supplied with the boiler in the plastic bag, into the fan outlet adaptor (see fig. 13).

The maximum allowed length for a smoke pipe of 80 mm dia. is 20 m, included a wide radius curve and one smoke terminal.

For this type of installation the chimney has to serve just one boiler, i.e. the boiler must have its independent smoke duct.

Fitting of the diaphragm Ø 42

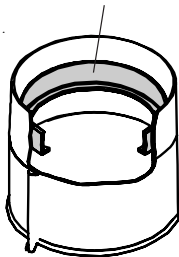

WARNING: For the smoke outlet configuration (see fig. 13-14) it is necessary to close the holes of air entry "1-2" with the provided for closing covers and the gaskets delivered with the boiler.



WARNING: For the installation where there is a freezing risk it is suggested to insulate the smoke duct 80 mm dia. on all its length, both in case it discharges from a vertical wall or in a chimney.

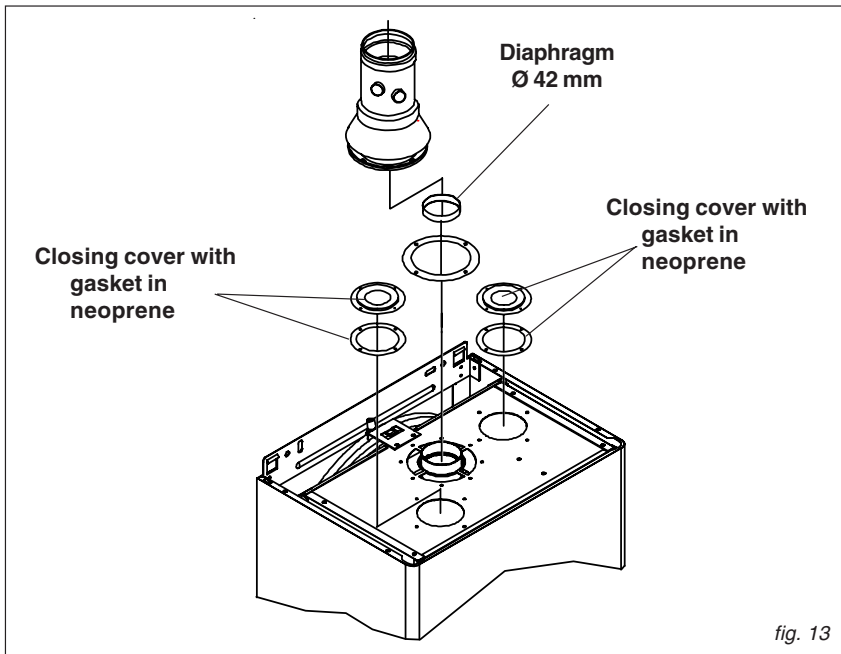

fig. 13

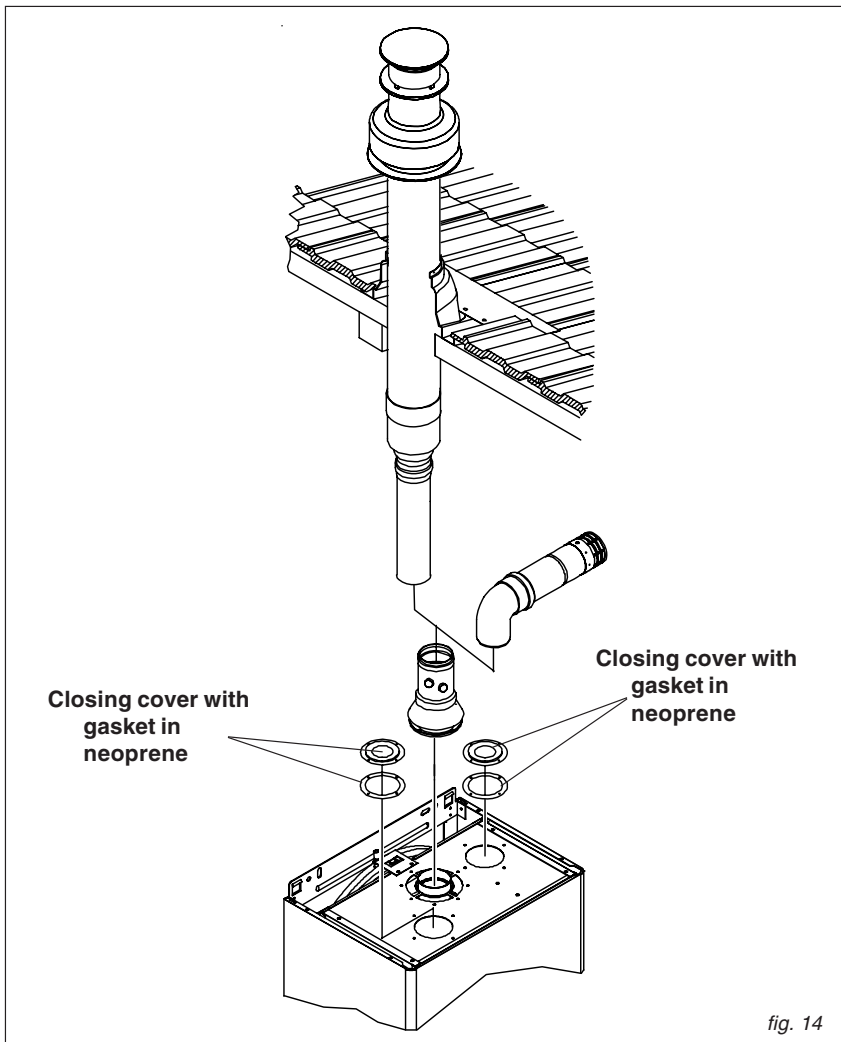

fig. 14

2.2.9 - DISCHARGE OF FLUE GAS INTO COAXIAL DUCTS Ø 100/60 mm

Type C12 Ø 100/60 mm

The minimum length of horizontal coaxial ducts is **0.5 metres**. The maximum allowable length of horizontal co-axial ducts is **3 metres**; for each additional bend the maximum allowable length must be reduced by 1 metre. Moreover, the duct must have a downward dip of 1% towards the outlet point to prevent rain water from getting into the duct.

Type C32 100/60 mm

The minimum length of vertical coaxial ducts is **0.5 metres**. The maximum allowable length of vertical coaxial ducts is **4 metres** excluding the stack (Ø 80/125); for each additional bend the maximum allowable length must be reduced by 1 metre.

The diaphragm Ø 42 supplied with the boiler must be inserted in the flue gas exhaust pipe as shown in figure 15, for installations with horizontal coaxial pipe up to 1 m and with vertical coaxial pipe up to 2 m.



WARNING: For the smoke outlet configuration (see fig. 15-16) it is necessary to close the holes of air entry "1-2" with the provided for closing covers and the gaskets delivered with the boiler.

Fitting of the diaphragm Ø 42

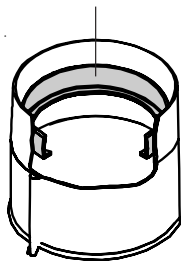

VERTICAL FLUE DUCT WITH COAXIAL DUCT Ø 80/125

Tipo C32 Ø 80 / 125

The minimum length of vertical coaxial ducts is **1,2 metres**. The maximum allowable length of vertical coaxial ducts is **6 metres** excluding the stack (Ø 80/125); for each additional bend the maximum allowable length must be reduced by 1 metre.

The diaphragm Ø 42 supplied with the boiler must be inserted in the flue gas exhaust pipe, as shown in figure 16, for installations with a coaxial pipe up to 2,5 m.

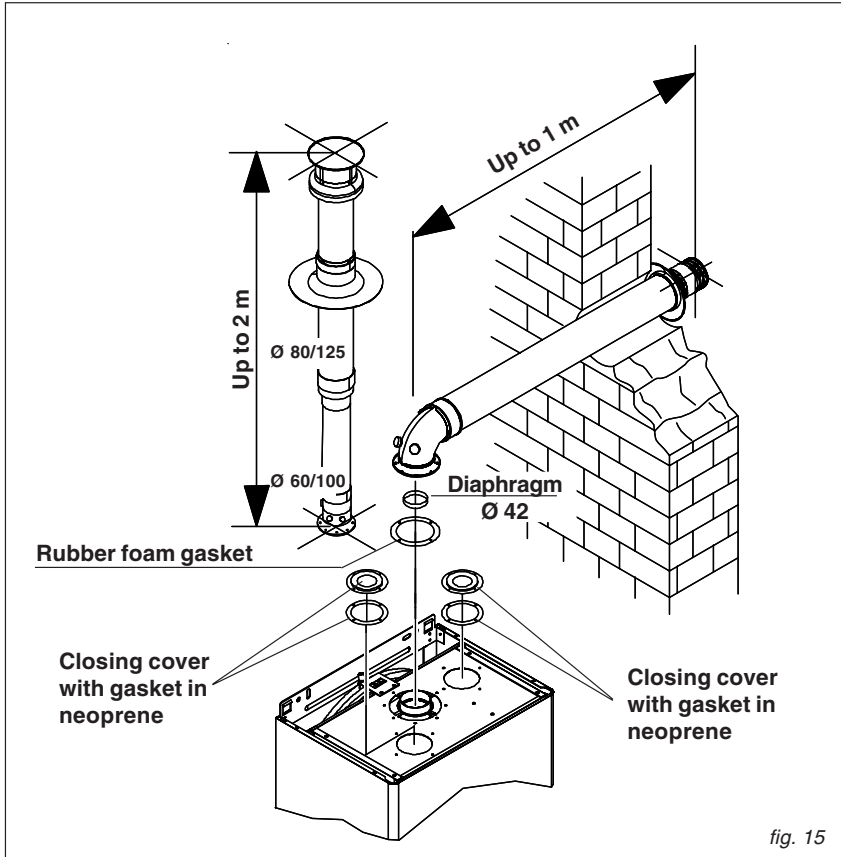

fig. 15

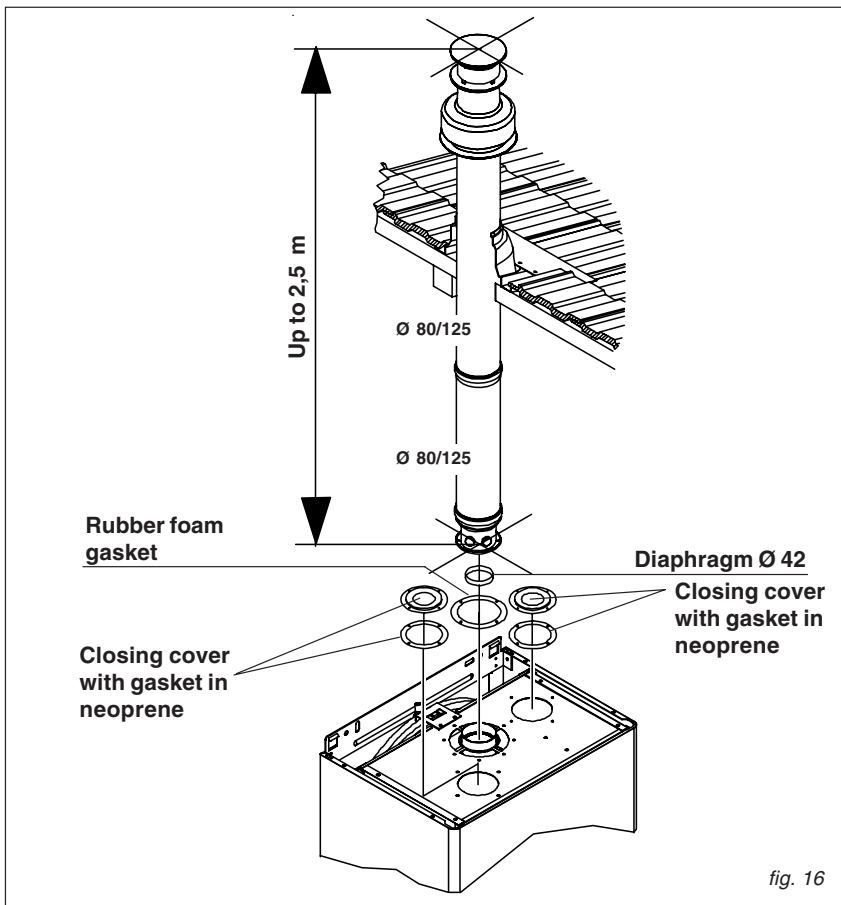
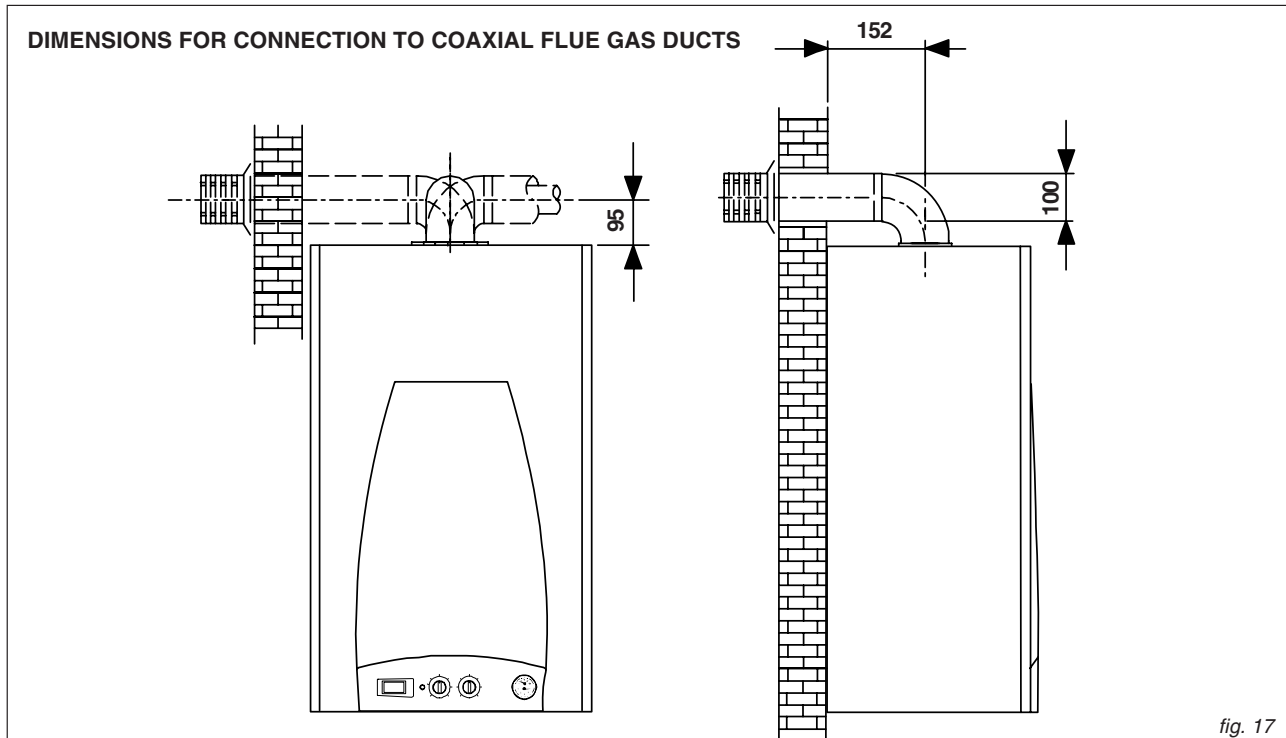

fig. 16



2.2.10 - FLUE GAS DISCHARGE AND AIR SUCTION WITH DUAL DUCTS WITH 80 mm DIAMETER

NB: The maximum allowable pressure loss, irrespective of the type of installation, must not exceed 50 Pa .

For all installations with a pressure loss of the ducts not exceeding 20 Pa, the diaphragm supplied with the boiler must be installed inside the flue gas outlet pipe (see fig. 18).



WARNING: Per For the smoke outlet configuration (see fig. 18) it is necessary to close the hole of air entry "1" with the provided for closing cover and the gasket delivered with the boiler. Note: in case the air aspiration will be effected by the hole "1", close the hole "2".



WARNING! In case the flue duct has to cross walls or floors, or if it is easily reachable, it is necessary to foresee a convenient insulation of such a duct. The flue duct, during the operation of the boiler can reach temperatures higher than 120°C.

IMPORTANT
Flue gas pressure switch operation

The boiler is fitted with a device controlling flue gas pressure. This device shuts down the boiler in the event of a malfunction.

This situation is indicated by the failure led

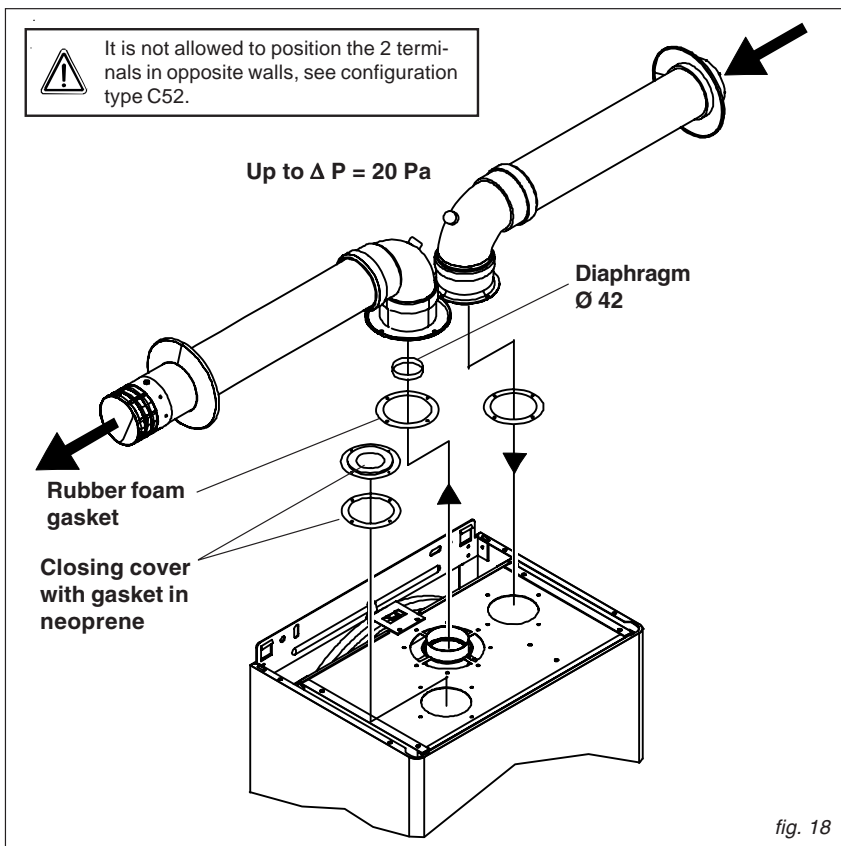

lighting on the display; by pressing the reset push-button the failure code "AF" is displayed and the boiler will repeat it's ignition sequence. If the reset button is not pressed

the boiler will in any case repeat it's ignition sequence after 10 minutes.

DIMENSIONS FOR CONNECTION THE AIR INTAKE AND THE FLUE GAS DISCHARGE WITH DUAL DUCTS

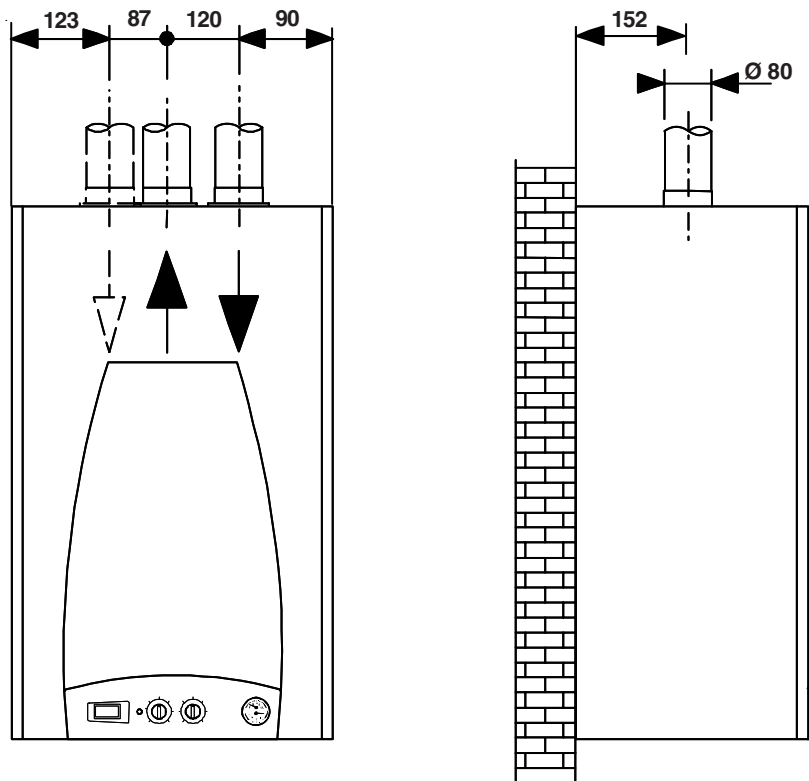

fig. 19

CONFIGURATIONS FOR SEPARATE PIPES (SUCTION AND OUTLET) Ø 80

Example N.1

Primary air suction from perimeter wall and flue gas discharge on roof.

Maximum allowable pressure loss:
50 Pa

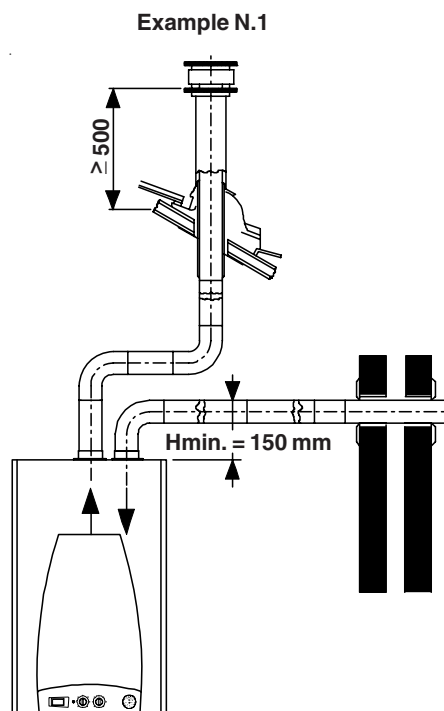

fig. 20

Example N.2

Primary air suction from perimeter wall and flue gas discharge from the same outside perimeter wall.

It is not allowed to position the 2 terminals in opposite walls,

Maximum allowable pressure loss:
50 Pa

CALCULATION OF PRESSURE LOSSES FOR DISCHARGE AND SUCTION DUCTS

Bear in mind the following parameters when calculating pressure losses:

- for each metre of duct with $\varnothing 80$ (both suction and discharge) the pressure loss is 2 Pa;
- for each $90^\circ \varnothing 80$ ($R=D$) bend with long radius, the pressure loss is 4 Pa;
- for each $90^\circ \varnothing 80$ ($R=1/2 D$) bend with short radius, the pressure loss is 14 Pa
- for the $\varnothing 80 L = 0.5$ m horizontal air inlet terminal, the pressure loss is 3 Pa;
- for the $\varnothing 80 L = 0.6$ m horizontal discharge end section, the pressure loss is 5 Pa;



NB: These values refer to discharges through original UNICAL non-flexible and smooth ducts.

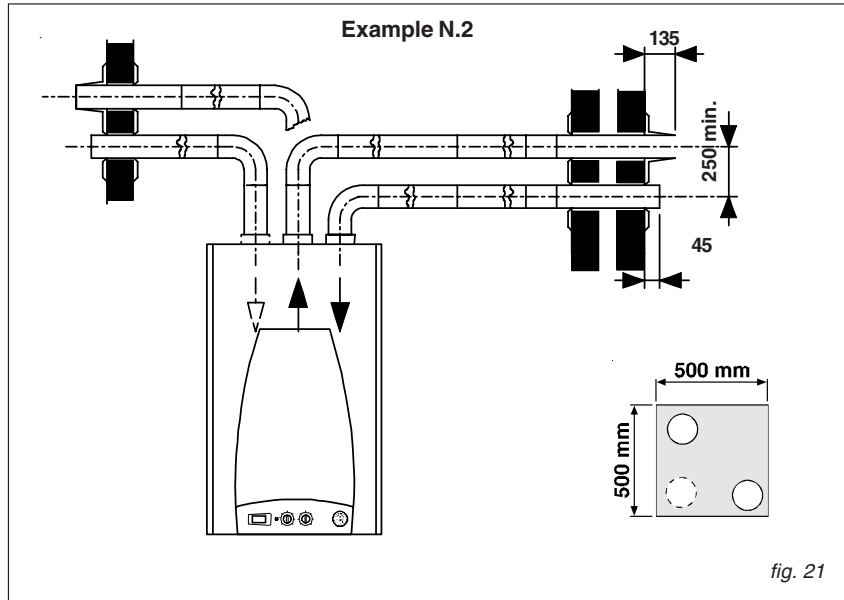

fig. 21

Example of check using wide radius bends:

- 17 mt duct $\varnothing 80 \times 2 = 34$ Pa
- $2 \times 90^\circ \varnothing 80$ long radius bends $2 \times 4 = 8$ Pa
- horizontal $\varnothing 80$ air inlet terminal = 3 Pa
- horizontal $\varnothing 80$ terminal = 5 Pa

Tot. pressure loss = 50 Pa

2.2.11- MEASUREMENTS OF COMBUSTION EFFICIENCY

Ducts $\varnothing 80$ type B22 (C)

Coaxial ducts (A)

Dual ducts $\varnothing 80$ (B)

To determine combustion efficiency the following measurements must be made:

- the combustion air temperature measured in hole 2 (see fig. 22).
- the flue gas temperature and CO_2 % measured in hole 1 (see fig. 22).

Make these measurements with the boiler running in a steady state condition.

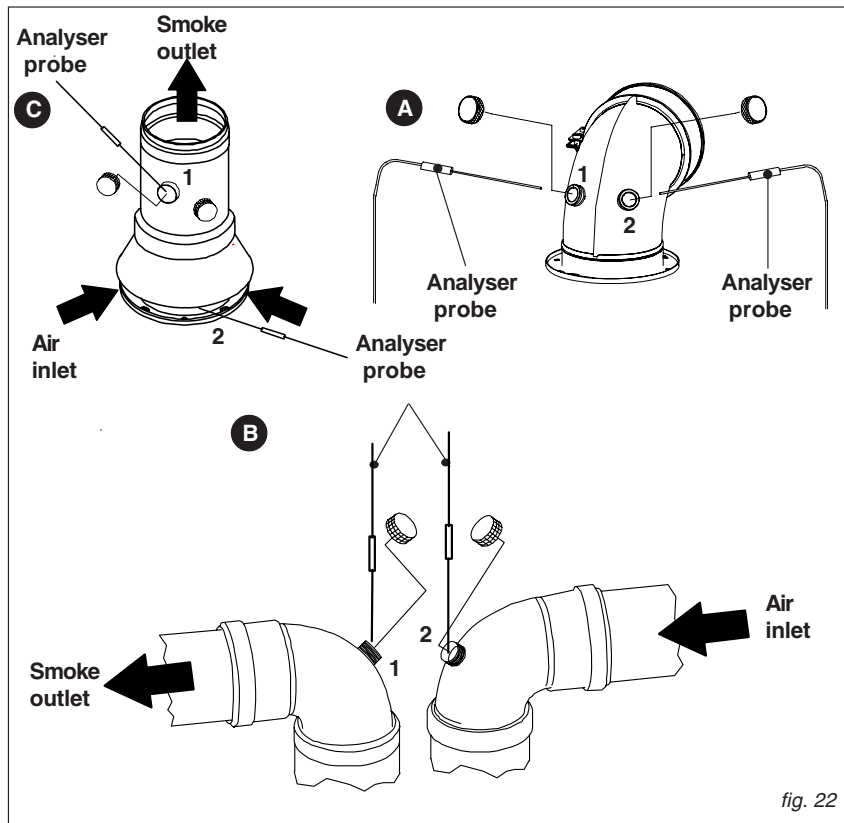

fig. 22

2.2.12 - CONNECTION TO THE GAS MAINS

The supply pipe must have a section which is the same as or greater than the one used in the boiler.

Comply with the applicable local installation requirements which shall be considered as having been incorporated in full in this manual.

Before opening the internal gas supply system; i.e. before connecting the gas meter, all seals must be checked.

If any part of the system is concealed the seals must be checked before the pipes are covered.

red.
The seal test must be conducted using air or nitrogen at a pressure of at least 100 mbar.

The commissioning of the boiler also includes the following operations and checks:

- Opening of the gas gate valve and venting of the air contained in the piping and appliances, proceeding appliance by appliance.
- Check, with the gate valve of all the appliances Off, that there are no gas leaks.

During the 2nd quarter of a hour from the beginning of the test no pressure reduction is to be detected on the gas pressure gauge. If gas leaks have to be found, use only water soap solution or any other specific gas leak detector which can be available on the market. Never look for gas leaks using a naked flame.



While connecting gas inlet pipe of the boiler to the pipe coming from gas network, it is MANDATORY to insert a TIGHT GASKET, whose dimensions and material must be adequate. Connection is NOT suitable for hemp, teflon strip or similar materials

2.2.13 - HYDRAULIC CONNECTION

Before installing the boiler we recommend that the system be cleaned to remove any impurities which could originate from components and which could risk damaging the circulating pump and heat exchanger.

Note: The use of solvents could damage the components of the heating circuit.



Basing on the feeding water hardness, it has to be considered the opportunity to install appropriate devices for water treatment (for domestic use). With feeding water hardness higher than 14° it's always recommended the water treatment.



HEATING

The heating flow and return must be connected to the relevant 3/4" connections of the boiler **M** and **R** (see fig. 9).

When determining the size of the heating circuit pipes it is essential to bear in mind the pressure losses induced by radiators, any thermostatic valves, radiator cut-off valves and the configuration of the system.

In the boiler, onto a brass group, positioned between the flow and return, an automatic by-pass device is fitted (a differential valve with a flow rate of about 150 l/h) which guarantees always minimum flow rate through the heat exchanger, also in the case, for instance, that all the thermostatic valves fitted on the radiators, are closed.

On boilers model: RTN 24 – CTN 24 F – RTFS 24 – CTFS 24 F the by-pass is automatic and pre-adjusted.

On boilers model CTN 24 – CTFS 24 is possible to adjust the by-pass by acting onto the adjusting screw

We recommend that the discharge of the safety valve mounted in the boiler be conveyed into the sewer.

If this precaution is not taken, activation of the safety valve may result in flooding of the room where the boiler is installed.

UNICAL shall not be held responsible for damage caused by non-observance of this technical precaution.

D.H.W.

Inlet and outlet of D.H.W. must be connected to the relevant 1/2" connections of the boiler **F** and **C** (see fig. 9).

The hardness of the supply water affects the frequency of the cleaning of the heat exchanger.



POSITION By-Pass CLOSE

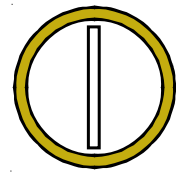

ADJUST By-Pass

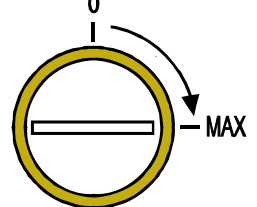

POSITION By-Pass OPEN

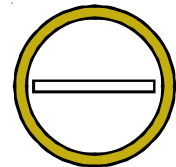

OPTIONAL CONNECTION KITS

INSTALLATION WITH VALVES
(00360682 + 00361193)

INSTALLATION WITH BENDED PIPES
(00361193 kit pipes)

INSTALLATION OF BEBDED PIPES AND PRESSURE FITTING 00361265

fig. 24

DIAGRAM FLOW RATE/MANOMETRIC HEAD AVAILABLE FOR THE CH SYSTEM

EVE 05 RTN 24 - EVE 05 RTFS 24

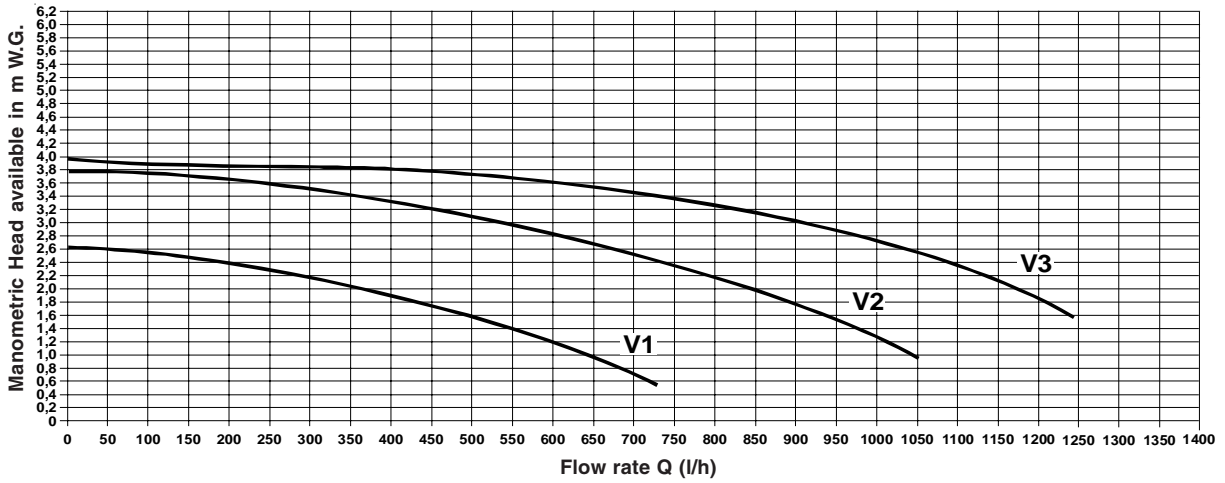

EVE 05 CTN 24 F - EVE 05 CTFS 24 F

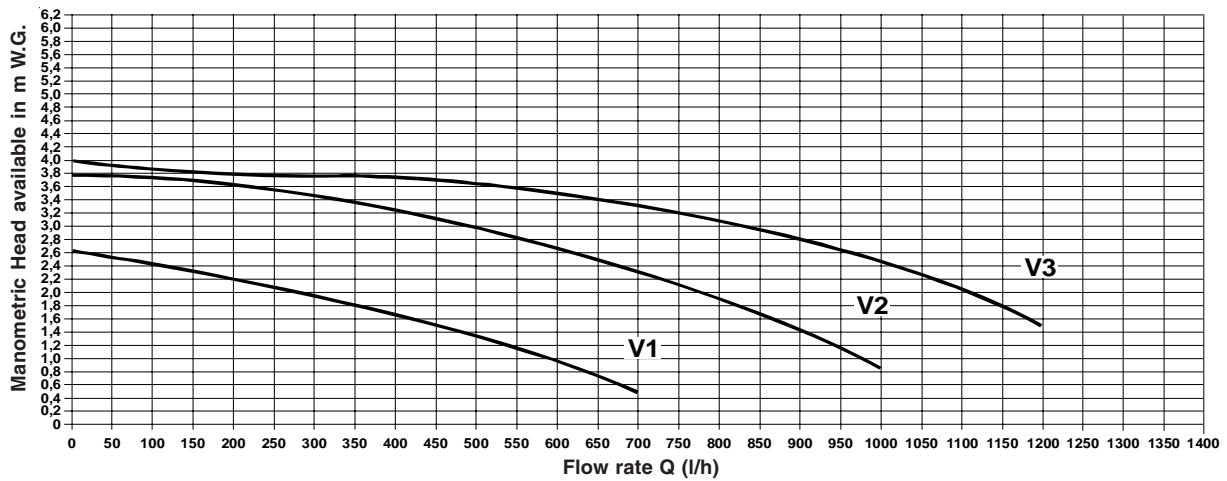

EVE 05 CTN 24 - EVE 05 CTFS 24

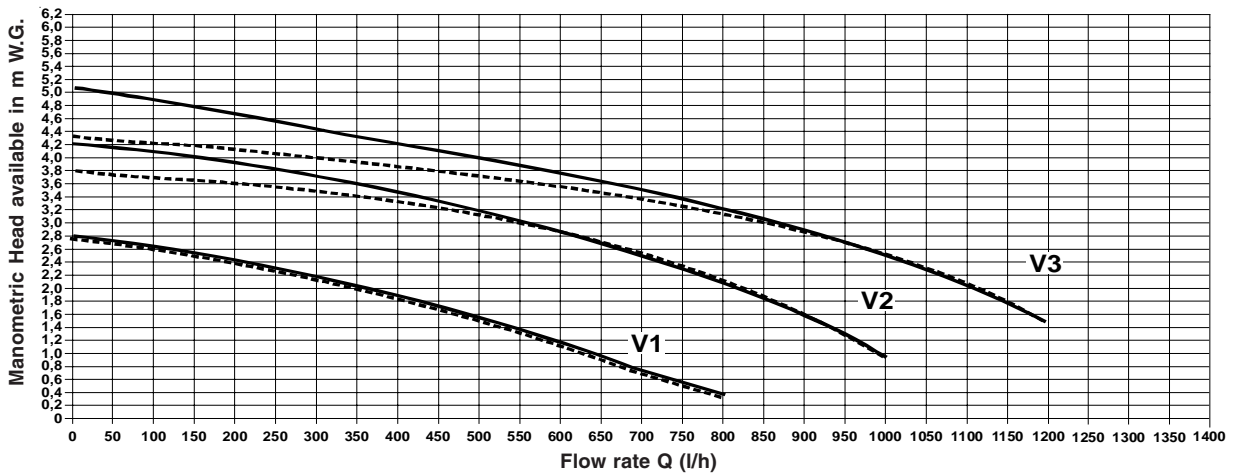

———— = By-Pass CLOSED
 - - - - - = By-Pass OPEN

Note: The boiler is delivered with the by-pass in OPEN position.

fig. 23

2.2.14 - ELECTRICAL CONNECTIONS

The electrical connections of **EVE 05** are shown in the clause "WIRING DIAGRAMS" (par. 2.3 - pag. 29)



The boiler must be connected to the mains supply at **230 V - 50 Hz**. This connection is to be perfectly done, as foreseen

by the IEC and local rules and must be earthed.

This fundamental requirement for safety purposes must be checked; in case of doubt, ask for a professionally qualified technician to check the electrical system.

UNICAL disclaims all liability for damage or injury caused by failure to earth the system properly.

Gas, domestic water and central heating pipes are not suitable for earthing purposes.

The boiler is supplied with 1.5 m long 3 x 0.75 mm² cord.

A double pole switch with a distance between the contacts higher than 3 mm, must be installed upstream the boiler to enable all maintenance operations to be carried out safely.

Access to the electrical terminal strip

- **WARNING!** Switch off the electrical supply
- Remove the securing screws **B** in order to rotate the control panel

- Remove the casing.
- To get access directly to the connections, unscrew the 4 screws on the panel cover (CP) and remove the cover.

Replacement of the electrical supply cord

The replacement of the electrical supply cord has to be done by competent technical personnel.

Should the electrical supply cord be replaced, you have to use the original cable code **95600259**.

- Open the rear cover (CP) and replace the cable A (connector A7)
The female faston of the heating cable has to be connected on the male faston GND 1

Connection of the ON/OFF room thermostat (RT)

- Approach the connector M1.
- Remove the existing jumper and connect, on its place the room thermostat cable.

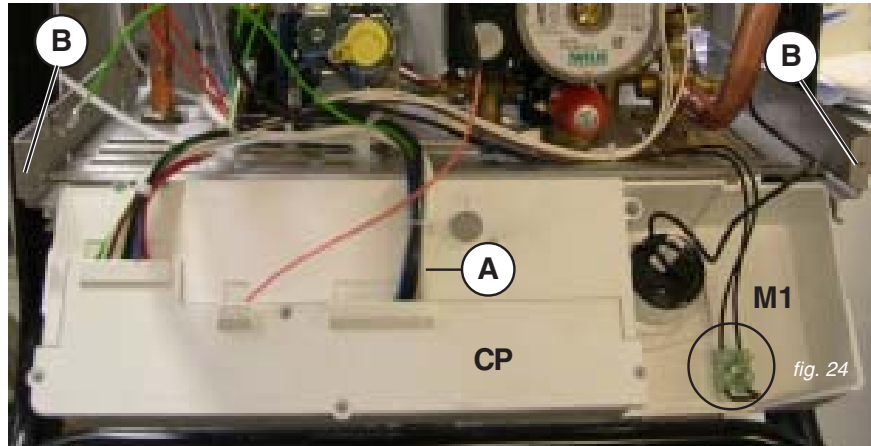

Collegamento ad un bollitore esterno

It is necessary to make the electrical connection as indicated.

The diverting valve has to be fitted with the priority to the DHW circuit and the microswitch, whose its motor must be equipped, has to be closed once the DHW has been satisfied and the valve is returned in the normal position.

The microswitch contacts C. and N.C. have to be connected to the two pole terminal block (TA), fitted on the boiler panel board, after removal of the existing link (bridge - shunt).

The connection of a room thermostat will be done onto the same terminals, in parallel with the contacts of the diverting valve.

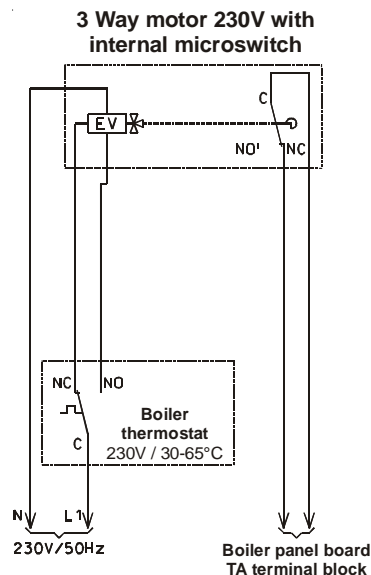

2.2.15 - JUMPER LOCATION

They are placed on the modulation card and their purpose is to settle basic operational functions.

In order to get access to the jumper:

- **WARNING!** switch off electrical supply.
- Remove the casing.

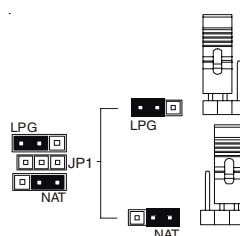

- JP1:** For nat. gas boilers, the jumper is on **NAT**.
For LPG boilers, the jumper is on **LPG**.

The boilers operating with natural gas will attempt the ignition for 3 times before to be put in lock-out.

The boilers operating with LPG will be put in lock-out after a single ignition attempt.

2.3 WIRING DIAGRAM

2.3.1 ACTUAL WIRING DIAGRAM

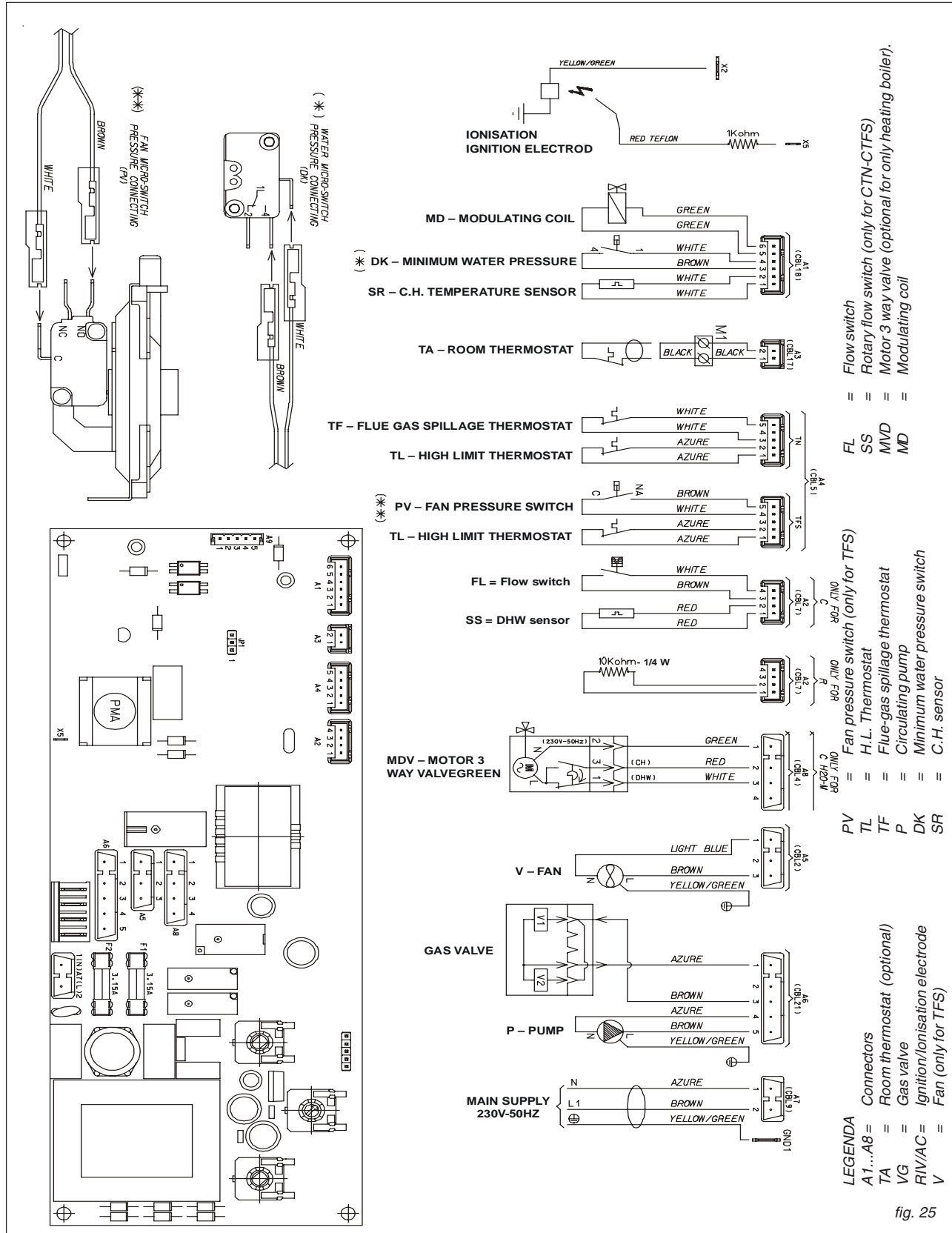

fig. 25

TABLE OF RESISTANCE VALUES AS A FUNCTION OF THE TEMPERATURE OF THE HEATING SENSOR (SR) AND D.H.W. SENSOR (SS) with a nominal resistance of ten kOhm

T°C	0	1	2	3	4	5	6	7	8	9
0	32755	31137	29607	28161	26795	25502	24278	23121	22025	20987
10	20003	19072	18189	17351	16557	15803	15088	14410	13765	13153
20	12571	12019	11493	10994	10519	10067	9636	9227	8837	8466
30	8112	7775	7454	7147	6855	6577	6311	6057	5815	5584
40	5363	5152	4951	4758	4574	4398	4230	4069	3915	3768
50	3627	3491	3362	3238	3119	3006	2897	2792	2692	2596
60	2504	2415	2330	2249	2171	2096	2023	1954	1888	1824
70	1762	1703	1646	1592	1539	1488	1440	1393	1348	1304
80	1263	1222	1183	1146	1110	1075	1042	1010	979	949
90	920	892	865	839	814	790	766	744	722	701

Relation between the temperature (°C) and nominal resistance (Ohm) of the heating sensor SR and D.H.W. sensor SS

Example: At 25°C, the nominal resistance is 10067 Ohm
At 90°C, the nominal resistance is 920 Ohm

2.4 - FILLING THE SYSTEM

After completing all the connections of the system the heating circuit can be filled. This filling operation must be performed with care as follows:

- open the air vents of the radiators and check that the automatic air vent in the boiler is works properly;
- gradually open the water tap and check operation of any automatic air vents installed in the system;
- close the air vents on the radiators as soon as water comes out;
- use the pressure gauge on the boiler to check that the pressure has reached the value of 0.8/1bar;
- close the water inlet tap and then release the air again through the radiator air vents;
- after switching on the boiler and after the system has reached the correct temperature, stop the pump and repeat the air relief operations;
- let the system cool down and then adjust the water pressure to 0.8/1 bar.

WARNING

The minimum water pressure switch does not give electrical impulse to the burner to ignite when the pressure is lower than 0.4 bar. The pressure of the water in the C.H. system must not be lower than 0.8/1bar; if this value is lower use the water filling tap on the boiler to adjust the pressure. This must be performed when the system is cold. Use the pressure gauge on the boiler to read the pressure value of the circuit.



NB: After a given period of inactivity and without electrical supply the pump could be

blocked.

Before switching on the boiler it is important to restart the pump as follows: loosen the protection screw in the centre of the pump motor, insert a screwdriver in the hole and then manually rotate the pump shaft clockwise.

Once the pump has been restarted tighten the protection screw and check that there are no water leaks.

WARNING

Once the protection screw has been removed a little water may leak out. Before replacing the casing of the boiler dry any wet surfaces.

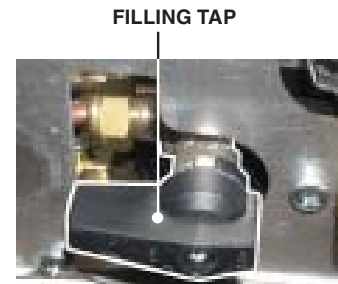

Filling position



Normal position

fig. 26

2.5 - STARTING THE BOILER

PRELIMINARY CHECKS

Before starting the boiler check that:

- the boiler installation has been made in accordance with all the applicable regulations concerning water and gas installation, smoke evacuation and electrical installation
- the flue gas exhaust duct and its terminal are installed correctly: **when the boiler**

is switched on there must be no leakage of any combustion products from any seals;

- the supply voltage of the boiler is 230 V-50 Hz;
- the system is correctly filled with water (pressure at the gauge 0.8/1 bar);
- any gate valves taps of the system are open;
- the mains gas corresponds to that with which the boiler has been calibrated: otherwise, convert the boiler to use the gas available (see section: "MODIFICATION FOR OTHER GASES"): **this ope-**

ration must be performed by qualified technicians;

- the gas supply tap is open;
- there are no gas leaks;
- the external mains switch is on;
- the boiler's safety valve is not locked;
- there are no water leaks.

SWITCHING ON AND OFF

To switch on and off the boiler follow the indications in the "Users' Instructions".

2.6 - ADJUSTING THE BURNER

All the instructions below are for the exclusive use of **qualified technicians**.
All the boilers leave the factory calibrated and tested.

If it is necessary to change the calibration following changes in the type of gas or adaptation to the supply network conditions, it is necessary to recalibrate the gas valve.

WARNING: During these steps do not draw Domestic Hot Water.

For that reason it is necessary to know the boiler operation in chimney-sweeper mode. In order to activate this function, push and keep depressed the reset push button for 3 seconds, on the control panel, then push once again the same button: the display symbols "F" and "L" will be lighted (F: blinking – L: fixed) and the boiler will operate at the maximum capacity. By pushing again the reset push button: the display symbols "F" and "L" will be lighted (F: blinking – L: fixed) and the boiler will operate at the minimum capacity. The chimney sweeper function remains active for 15 minutes. For cleaning this function before this fixed period, switch OFF and ON the boiler. To correctly regulate the gas valve, follow the steps below:

1) Maximum output adjustment

- check the value of the supply pressure (see table NOZZLES - PRESSURES);
- Remove the cover (A) protecting the pressure regulator on the top of the modulating coil.

Connect a manometer at the outlet gas pressure test nipple (fig. 28).

Activate the chimney sweeper function to the maximum capacity ("F" blinking; "L" fixed); when the burner is ignited, check that the "MAXIMUM" pressure value corresponds to that indicated on the table "NOZZLES - PRESSURES":

- Correct eventually the value rotating the nut "C" with a 10 mm wrench (fig. 28); by rotating clockwise, the gas pressure increases, anticlockwise the gas pressure is reduced.

2) Minimum output adjustment

- Push a second time the reset push button and the boiler will operate at the minimum capacity (both leds F and L will blink).
- When the burner is ignited, check that the MINIMUM pressure value corresponds to that indicated on the table "NOZZLES – PRESSURES, etc.
- Correct, eventually, the value rotating the red screw "B" with a cross-screw driver or a 6 mm wrench (fig. 28): by rotating clockwise the gas pressure increases, by rotating counter clockwise the gas pressure decreases

CHIMNEYSWEEPER ACTIVATION

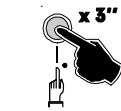

Push the reset push button for 3 seconds

OPERATION AT THE MAXIMUM CAPACITY

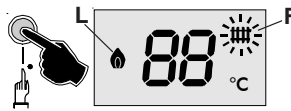

Push again the reset push button; the symbol "F" (Central Heating) blinks, the symbol "L" (burner in operation) is fixed.

OPERATION AT THE MINIMUM CAPACITY



Push again the reset push button; the symbol "F" (Central Heating) and the symbol "L" (burner in operation) are both blinking

fig. 27

GAS VALVE

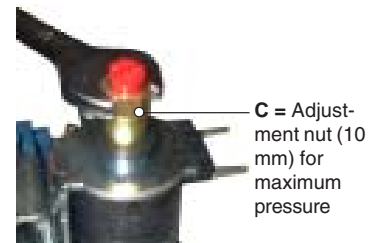

C = Adjustment nut (10 mm) for maximum pressure

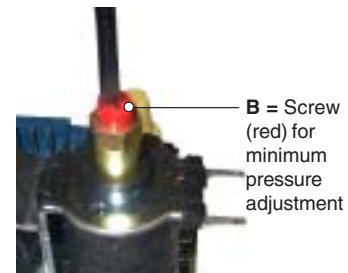

B = Screw (red) for minimum pressure adjustment

fig. 28

3) Ending of basic adjustments

- check the minimum and maximum pressure values of the gas valve;
- if necessary make any fine adjustments
- Clear the chimneysweeper function by cutting off the voltage.
- Remove the plastic pipe from pressure test nipple and close the inner screw;
- **Using a soapy solution check for gas leaks.**

PRESSURE TEST NIPPLE



fig. 29

2.7 - MODIFICATION FOR OTHER GASES

The boilers are manufactured for the type of gas specifically required upon order. Any subsequent conversion must be performed by qualified technicians who will use the kits supplied by **Unical** and perform the conversion and required adjustments for correct preparation of the boiler for use. To convert the boiler from one type of gas to another proceed as follows:

for conversion from natural gas to LPG

- remove the main burner;
- disassemble injectors of the main burner and replace them with those with a diameter corresponding to the new type of gas (see table "INJECTORS - PRESSURES");
- reassemble the main burner;
- position the jumper on the modulation PCB in the panel board as shown in figure 31;
- remove plug "A" (fig.28) on the gas valve and fully tighten max pressure adjustment screws "B"
- check the pressure value upstream the gas valve (see table "INJECTORS - PRESSURES") and adjust the pressure of the burner as indicated in section "ADJUSTING THE BURNER"
- check that the burner is functioning properly;
- **check that there are no gas leaks.**
- tighten the plug "A" (fig.28) of the max pressure adjustment screw
- when the conversion is completed, fill in

the label supplied in the kit with the information required and stick it onto the boiler alongside the data plate.

for conversion from LPG to natural gas

- remove the main burner;
- disassemble injectors of the main burner and replace them with those with a diameter corresponding to the new type of gas (see table "INJECTORS - PRESSURES");
- reassemble the main burner;
- position the jumper on the modulation PCB in the panel board as shown in figure 31;
- remove plug "A" (fig.28) on the gas valve
- check the pressure value upstream the gas valve (see table "INJECTORS - PRESSURES") and adjust the burner pressure as indicated in section "ADJUSTING THE BURNER";
- check that the burner is functioning properly;
- **check that there are no gas leaks.**
- tighten the plug "A" (fig.28) of the max pressure adjustment screw;
- when the conversion is completed, fill in the label supplied in the kit with the information required and stick it onto the boiler alongside the data plate.

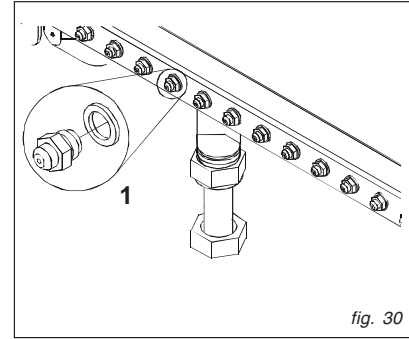

fig. 30

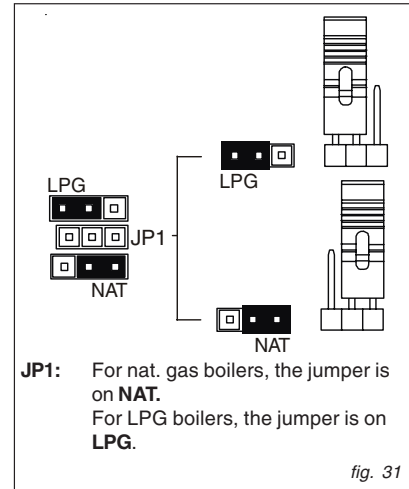

fig. 31

NOZZLES - PRESSION - DIAPHRAGME - CONSUMPTION TABLE

The pressures at the burner indicated in the following table must be checked after the boiler has been operating for 3 minutes.

EVE 05 CTN 24 F - EVE 05 CTN 24 - EVE 05 RTN 24

Type of gas	Output min. - max (kW)	Input min. - max (kW)	Supply pressure (mbar)	Ø Nozzles (mm)	No. of Nozzles	Ø Diaphragme (mm)	Burner pressure		Gas consumption	
							min. (mbar)	max (mbar)	min.	max.
Natural gas(G20)	10,17 - 24,0	11,5 - 26,5	20	1,25	12	-	2,7	13,3	1,22 m³/h	2,80 m³/h
Propan (G31)	10,17 - 24,0	11,5 - 26,5	37	0,80	12	-	6,2	33,0	0,89 kg/h	2,06 kg/h

EVE 05 CTFS 24 F - EVE 05 CTFS 24 - EVE 05 RTFS 24

Type of gas	Output min. - max (kW)	Input min. - max (kW)	Supply pressure (mbar)	Ø Nozzles (mm)	No. of Nozzles	Ø Diaphragme (mm)	Burner pressure		Gas consumption	
							min. (mbar)	max (mbar)	min.	max.
Gas nat. (G20)	9,9 - 24,2	11,5 - 26,5	20	1,30	12	-	2,3	12,0	1,22 m³/h	2,80 m³/h
Propano (G31)	9,9 - 24,2	11,5 - 26,5	37	0,80	12	-	6,2	33,0	0,89 kg/h	2,06 kg/h

2.8 FAILURE CODES

In case of failure the burner is automatically deactivated and the symbol  on the display is shown. By pushing the reset button the failure blinking code is shown on the display.

Each fault is characterised by a priority level : if different failures are detected at the same time, the code with the highest priority level is shown.

The following failure codes are recognised:

2.10.1 Lock-out (priority 1)

Description:

Modureg coil interrupted

Possible solution:

verify the wiring, replace the modureg

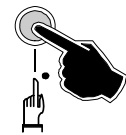
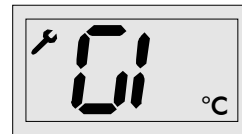

2.10.2 Lock-out (priority 2)

Description:

Fault at the fan pressure switch

Possible solution:

Verify the fan pressure switch (TFS version) and the electric connections or replace the main PCB.

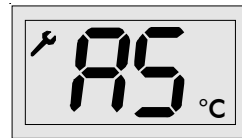

2.10.3 High temperature (priority 3)

Description:

Overheating of the boiler

Possible solution:

verify the correct operation of the pump and, eventually, descale the heat exchanger.

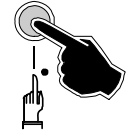
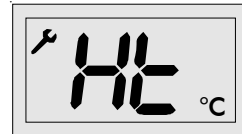

2.10.4 Difficult smoke evacuation (priority 4)

Description:

Difficult smoke evacuation

Possible solution:

TN boilers: verify the chimney draught, or the smoke thermostat.
TFS boilers: verify the fan and its own pressure switch operations.

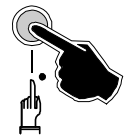
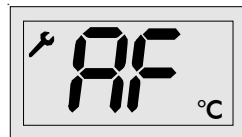

2.10.5 Lack of water (priority 5)

Description:

Insufficient water pressure: intervention of minimum water pressure switch.

Possible solution:

Set the water pressure by the filling valve and look for possible leakages. If the code appears again, call the service technician.

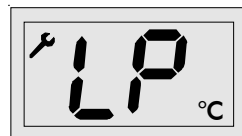

2.10.6 FROST (priority 6)

Description:

Freezing of the heat exchanger is detected if CH sensor < 2°C; ignition is inhibited until CH sensor reaches 5°C.

Possible solution:

Cut off the voltage, close the gas feeding, call the service technician.

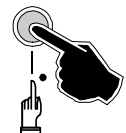
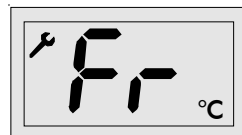

2.10.7 High Limit thermostat (priority 7)

Description:

High limit thermostat intervention

Possible solution:

Verify the water circulation into the heat exchanger; verify that the high limit thermostat and its own connections are not interrupted

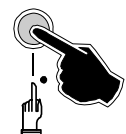
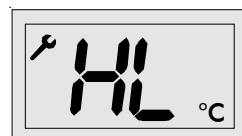

2.10.8 Sanitary sensor (priority 8)

Description:
Sanitary temperature sensor intervention

Possible solution:
verify the sensor operation and its own connections

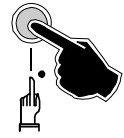
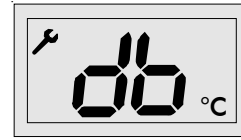

2.10.9 Heating sensor (priority 9)

Description: Heating temperature sensor intervention

Possible solution: verify the sensor operation and its own connections

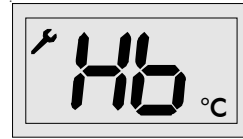

2.10.10 Factory parameters (priority 10)

Description:
Factory parameters alteration

Possible solution:
with the access code, reset the 13 factory parameters

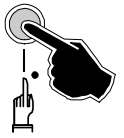
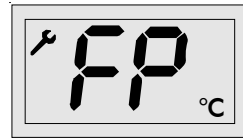

2.10.11 Flame control (priority 11)

Description:
Burner control is damaged.

Possible solution:
replace the main PCB.

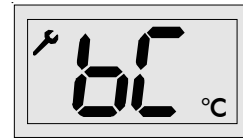

2.10.12 Lock-out

Description:
Lack of gas or burner ignition not detected

Possible solution:
verify the gas feeding and the correct operation of the ignition electrode

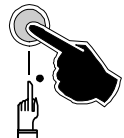
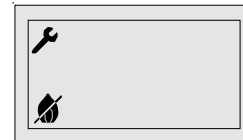

The tool blinks, by pushing the reset push button no failure codes are displayed.

3

USERS' INSTRUCTION

3.1 - CONTROL PANEL

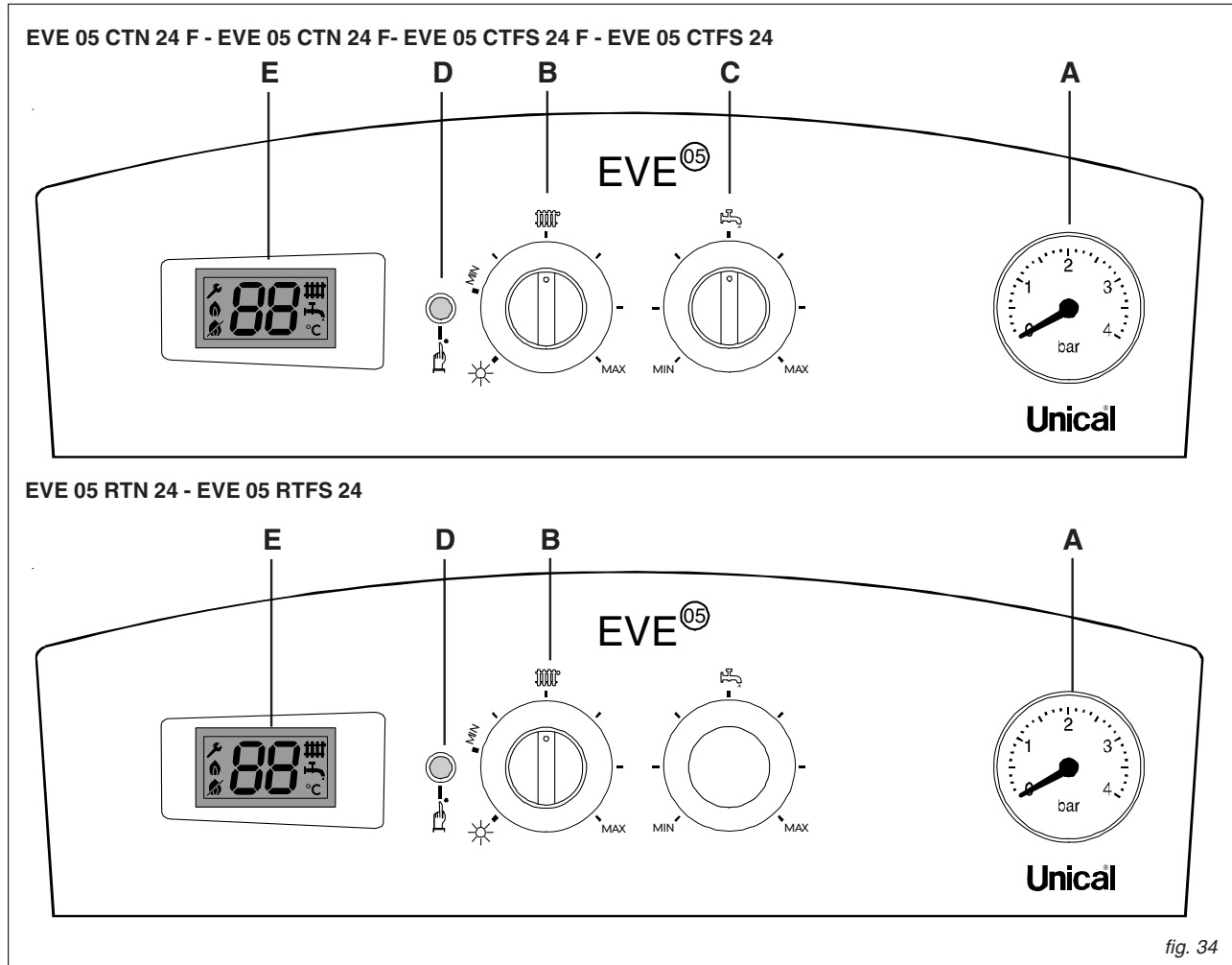
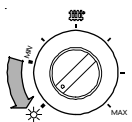

fig. 34

- A = Manometer
- B = Summer / Winter switch + C.H. temperature control
- C = D.H.W. temperature control (only for combi C version)
- D = Reset button / chimney sweeper / diagnostics
- F = CH mode active
- G = DHW mode active
- I = Lock out
- L = Burner in operation
- M = Failure
- N = Temperature or failure code indication



Summer/Winter switch + C.H. temperature control (B)

You can select which mode to use by turning this knob.

If the knob is in the following position – ☀ – it indicates that the boiler is working only for domestic hot water production and that the temperature can be adjusted turning knob "C".

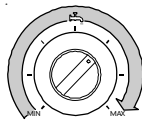

If the knob is set within the range indicated by the arrow on the illustration it means that the boiler always gives priority to the production of domestic hot water (if it is requested) and controls the temperature of the water of the

heating circuit from a minimum of 45°C to a maximum of 78°C.

D.H.W. temperature control (C) (Only for EVE 05 CTN 24 F - EVE CTFS 24/28 F)

If the knob is set within the range indicated by the arrow on the illustration it means it is possible to adjust the domestic hot water temperature. The temperature can be controlled from a minimum of 35°C to a maximum of 57°C.



By adjusting the Domestic Hot Water temperature to the real required temperature, you will avoid to mix hot

water with cold water, in this way reducing both the boiler operation costs and the scaling formation.

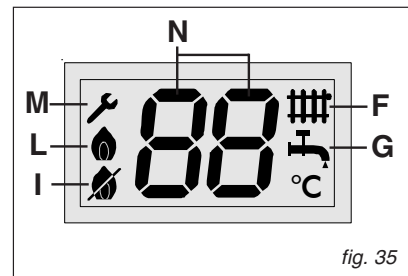

fig. 35



Burner in operation

This symbol indicates that the burner is in operation, in CH or DHW mode.



CH mode operation

This symbol is present if there is a CH demand. If a contemporary DHW drawing is done, this symbol disappears.



DHW mode operation

This symbol is present if there is a DHW drawing.



Lockout symbol

The function of this symbol is to indicate the burner safety intervention, due to:

- lack of gas
- not detected ignition

In the first case, no ignition occurs: verify that the gas feeding is present.

In the second case, check the ignition electrode and the connections to the main PCB.



Reset push button

In order to restart the boiler when the lockout symbol is displayed, it will be necessary to push this button.

x 3"



Chimney sweeper button

This push button, depressed for 3 seconds, activates the chimney sweeper function: the boiler will be forced to operate at the maximum (or minimum) capacity, in order to allow the gas valve adjustment and the smoke analysis.

When this function is activated, by pushing this button once, the boiler will operate at maximum capacity. The radiator symbol will be blinking, while the flame symbol will be permanently lighted.

CHIMNEY SWEEPER AT THE MAXIMUM CAPACITY

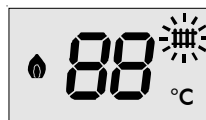

By pushing again the button (when the boiler is set to the maximum capacity), the boiler will operate at minimum capacity. The radiator and the flame symbols, both, will be blinking.

CHIMNEY SWEEPER AT THE MINIMUM CAPACITY



In order to clear this function switch OFF and ON the boiler; if not, the boiler will revert to normal operation after 15 minutes.



Failure symbol

The symbol is displayed when the boiler detects an operation anomaly or when the boiler is in lock-out for a permanent failure. The code identifying the cause is displayed instead of the boiler temperature by pushing the reset push-button.



3.2 SWITCHING ON / OFF

SWITCHING ON

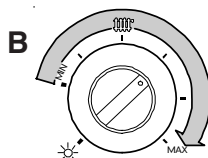

For the operation of the boiler in WINTER mode, the knob "B" pointer must be positioned in the grey range indicated by the arrow on the figure shown above. The limit of the arrow corresponds to the minimum and maximum temperature values of 45°C and 78°C.

Note: If a room thermostat is fitted, set it to the desired temperature.

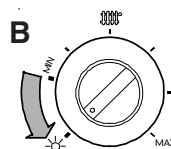

For the operation of the boiler in SUMMER mode, only for domestic hot water production, the knob "B" reference has to be positioned on the SUN ☀ and the D.H.W. temperature value has to be adjusted using the knob "C".

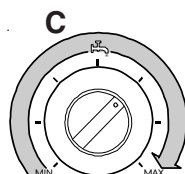

D.H.W. temperature adjustment range for the models: **EVE 05 CTN/CTFS**

SWITCHING OFF

Put the "B" knob on the SUN position and the "C" knob to the minimum.

Switch OFF the boiler by acting on the external main switch, provided the antifrost protection is not required; otherwise go to 3.3.



Shut OFF the gas cock upstream the boiler in case a prolonged inactivity period of the boiler is expected.

3.3 ANTI FROST PROTECTION

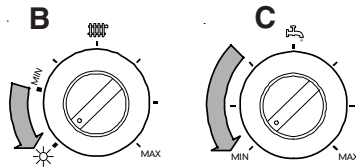

The boiler is fitted with an anti-freeze system which is automatically activated when the temperature of the boiler water drops below 6°C: the burner is automatically switched on and the pump started until the temperature of the water in the boiler reaches 16°C.



WARNING!

This anti-freezing protection does not work when the boiler is disconnected from the electrical supply and/or the gas cock is closed.

This system protects the boiler and the eventual DHW tank from freezing, but it does not protect the C.H. and sanitary circuits.

Moreover special anti-freeze products suitable for the multimetal installations can effectively protect the heating system from the freeze.

Do not use the anti-freeze products for car's engines because they can damage the water sealing gaskets.

The anti-freeze protection system, which is above described, can not work when, for any reasons, there is no electricity or gas supply.

When the temperature detected by the heating sensor is under 2 °C, the boiler's operation is automatically inhibited until the temperature raises again to 5 °C.

In case the display shows the wrench symbol and the Fr info on the display, call the service technician.

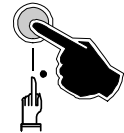
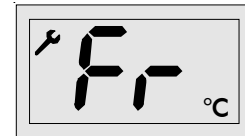

3.4 IMPORTANT SUGGESTIONS AND NOTES

The boiler must be serviced once a year by qualified personnel.

Correct maintenance allows the boiler to work optimally, respecting the environment and without endangering people, animals and property.

Only qualified and technical personnel can make adjustment onto the gas valve.

Nobody, included qualified personnel, is authorized to make modifications to the boiler.

Check regularly the pressure of the boiler water through the pressure gauge fitted onto the panel board, and restore it, if necessary.

If some fault appears during the operation, the boiler is automatically put in lockout position and the red warning lamp (G) lights. In this case proceed as follows:

- Ascertain that the gas cock is open and that there is gas in the gas pipe (try to ignite a gas cooker)
- If so, wait one minute before resetting the boiler by depressing the L push button. If the boiler does not start and goes into lockout position after three times, (just once if is operated on LPG) ask for a service or for a qualified technician.

If the boiler goes into lockout position frequently, indication of a repeatitive fault in the operation, ask for a service or for a qualified technician

WARNING

In case of an open flue boiler (TN) the burner lockout can be due to the intervention of the

smoke thermostat (antispillage thermostat). In this case to restart the boiler it is necessary to depress the reset push button L.

This fault, if repeated in the time, means a bad chimney operation. Ask a qualified technician for a check.

If the boiler remains inactive and disconnected from the power supply for long periods it may be necessary to unlock the pump.

This operation, for which it is necessary to disassemble the outside casing and work on the inside of the boiler, must be performed by qualified personnel.

It is possible to prevent the pump from blocking by adding special filming products suitable for multi-metal systems to the water.

If the boiler is not disconnected from the mains power supply the pump will not block because the boiler's PCB has an anti-jamming programme. In this case the pump goes into operation for a 5 seconds every 24 hour of inactivity.

The boiler is equipped with a pressure gauge which allows the control of the water pressure in the heating system.

The pressure of the water must be around 0.8-1 bar when the C.H. system is cold.

If this value drops then use the filling cock to adjust to the correct value.



WARNING

After adjusting the pressure, close the tap without over-tightening it. If the tap is not closed properly the pressure could rise, resulting in the safety valve opening and the water leaking.



WARNING

The anti-frost protection is operational only if the boiler is connected to the mains supply and the gas cock is open

Information for the user

The user can get access only to the parts of the boiler which can be reached without the need of tools.

It is therefore forbidden to disassemble the outer casing of the boiler and tamper with the internal parts.

Unical AG S.P.A.

46033 casteldario - mantova - italia - tel. 0376/57001 (r.a.) - telefax 0376/660556

The Unical declines every responsibility for the possible inaccuracies if owed to errors of transcript or press. Also reserves the right to bring those changes that it will hold necessary to its own products or profits, without jeopardizing its essential characteristics.

