

USER MANUAL
for
LADA GRANTA
AND ITS VERSIONS



Ф. 578-1

User Manual
for
LADA GRANTA
AND ITS VERSIONS

JSC «AVTOVAZ» • TOGLIATTI • RUSSIA

TABLE OF CONTENTS

<p>FOR YOUR ATTENTION! 3</p> <p>VEHICLE DESCRIPTION 6</p> <p>I. BODY AND PASSENGER</p> <p> COMPARTMENT 6</p> <p> Keys 6</p> <p> Remote control system <i>(in the design variant)</i> 7</p> <p> Remote control system operation . . . 8</p> <p> Immobilizer 11</p> <p> Doors 12</p> <p> Foot pedals location area 17</p> <p> Seats 17</p> <p> Steering wheel position adjustment <i>(in the design variant)</i> 19</p> <p> Seat belts 20</p> <p> Air bags 21</p> <p> Installation of child restraints 25</p> <p> Passenger compartment equipment 27</p> <p> Bonnet 31</p> <p> Trunk lid 32</p> <p> Fuel tank plug 33</p> <p>II. CONTROLS AND INSTRUMENTS . . 34</p> <p> Instrument panel 34</p> <p> Instrument cluster 36</p> <p> Liquid crystal display 41</p> <p> Gearshift prompter function 43</p> <p> Trip computer control <i>(in the design variant)</i> 44</p> <p> Lighting control module and dipped</p>	<p>beam adjuster 44</p> <p>Rain and light sensor 45</p> <p>Light alarm switch 46</p> <p>Wiper switch 46</p> <p>Ignition starter switch 48</p> <p>Gear change lever in mechanical transmission 49</p> <p>Gear change lever in automatic trans- mission <i>(in the design variant)</i> 50</p> <p>Automated transmission (AMT) instruction manual 51</p> <p>Ventilation and heating system control in the passenger compartment . . 53</p> <p>Ventilation and heating modes 56</p> <p>Radio receiver and media player . . 61</p> <p>VEHICLE OPERATION 62</p> <p> Number plate installation 62</p> <p> Safety vehicle operation basics . . . 62</p> <p> Vehicle driving 68</p> <p> Braking and parking 70</p> <p> Vehicle towing 72</p> <p> Defensive parking system 73</p> <p> Automatic transmission driving system features 75</p> <p>VEHICLE TECHNICAL MAINTENANCE AND CURRENT REPAIR 79</p> <p> Engine lubrication system 79</p> <p> Gearbox 80</p> <p> Automated gearbox 80</p>	<p>Automated gearbox gear change lever 81</p> <p>Engine cooling system 82</p> <p>Brake system 82</p> <p>Window washer system 83</p> <p>Storage battery 84</p> <p>Tyres and wheels 84</p> <p>Remote control battery replacement 87</p> <p>Fuse plug replacement 88</p> <p>Bulb replacement 97</p> <p>Body 101</p> <p>Exterior light and exterior light alarm instruments 103</p> <p>Vehicle storage 104</p> <p>VEHICLE TECHNICAL SPECIFICATION 105</p> <p> Vehicle main parameters and charac- teristics 105</p> <p> Filling volumes, l 111</p> <p> Passport details 112</p> <p>APPENDICES 114</p> <p> 1. Fuels and lubrications approved and recommended for operation of LADA Granta vehicle and its versions 114</p> <p> 2. Lamps used in the vehicle 116</p> <p> 3. Ignition plugs 117</p> <p> 4. User's manual for radio and audio file player 117</p>
--	---	---

FOR YOUR ATTENTION!

Thank you for your choice and decision to purchase LADA.

Before operating your vehicle, please read this maintenance manual! It will introduce you to the features of its design, controls, equipment, as well as safety requirements and operation rules.

The vehicle has high dynamic qualities, that's why in the initial period of its operation, regardless of your driving experience, **you should exercise caution until you have fully mastered the technique of its driving.**

When driving, to ensure safety traffic without any accidents do not quit hold of steering wheel.

The vehicle is intended to transport people and luggage (in quantity and weight declared by the manufacturer – see the Table in the section «Vehicle technical specification») at ambient temperature of minus 40 °C to plus 45 °C on hard surface open roads.

If necessary drive along broken-stone roads or hobs it is recommended to choose the mode that:

- can preserve protective covers of suspension, front wheel drive, as well as protective coverings of body from being damaged with crushed aggregates;
- can eliminate or minimize sharp blows of suspension and strong torsion loads on the body.

Maximum climbing is at most 30%.

The vehicle complies with the Russian Federation and International requirements specified to the performance and safety indexes. Compliance with these requirements is certified by relevant authorities of the Russian Federation and certificated authorities of EEC countries, by issuing the «Vehicle type approval», the number of which is specified in the summary factory data table (See figure in the section «Name plate data»).

During operation, avoid damages to the vehicle, which include those following as a result of mechanical, chemical, thermal, and other external factors, as well as traffic accidents, as these damages affect the overall technical condition of the vehicle, safety of its operation, consumer properties and ability to use in accordance to its purpose within the vehicle life period specified by the manufacturer.

Remember that every marking, identification tags and labels on the parts and components of your vehicle must be maintained until the end of life period, otherwise the manufacturer (the authorized person) reserves the right to refuse to satisfy the requirements of the owner to repair or replace the defective part or component.

Fit for purpose and fulfilment of consumer properties by the vehicle during the life period specified by the manufacturer is provided with a set of measures for storage, operation, care and maintenance specified by the manufacturer, which are mandatory for the owner of the vehicle or any person using it.

Remember – you has the responsibility to keep the vehicle in good working condition, and wherefore

remind you of the obligation to comply with the timeliness and completeness of all maintenance work described in the vehicle log book, as well as all the necessary current repairs.

To keep the manufacturer's warranty in force you should carry out maintenance, repair and installation of additional equipment on the vehicle at service and sales network enterprises (SSNE) certified by the manufacturer with the mandatory mark in the vehicle log book.

Certified SSNEs use service and repair technology of vehicles that was developed by JSC «AVTOVAZ»; they are equipped with all special equipment and instrument.

Timely scheduled maintenance and repair work essentially influences technical condition of the vehicle, provides durability and performance characteristics of the vehicle. After the maintenance check that the personnel, carrying out it, added all the corresponding notes in the vehicle log book.

During operation and maintenance of the vehicle use the materials the list of which is specified in this manual.

During the operation of the vehicle

use only recommended and high-quality gasolines and motor oils, otherwise it will result in bulk deposits on engine parts, failure of control system and emission reduction system components, failure of exhaust converter.

Do not use gasolines with metalorganic antiknocks based on lead (leaded petrol), iron (ferrocenes), manganese, nickel and other metals.

The vehicle's engine is filled at the manufacturing factory with oil of SAE 5W-30 viscosity class, designed for use in ambient temperatures of minus 30 °C to plus 25 °C. If a new vehicle is operated, including outside of this temperature range, it is necessary to change the oil for the recommended in Annex 1, without waiting for oil change period according to the vehicle log book.

Do not use secondary additives to gasolines and lubricating oils.

The owner of the vehicle bears the responsibility for the use of poor-quality gasolines and oils. Carry out installation of any additional devices on the vehicle, as well as **replacement, modification of hardware or software of EECS controller at the certified SSNEs** with the mandatory mark

in the section «Observation page» of the vehicle log book. **Certified SSNEs have the list of additional equipment approved for installation by JSC «AVTOVAZ» and specifically developed technologies for its installation.** Otherwise, JSC «AVTOVAZ» is not responsible for any possible consequences that may arise after installing additional devices.

Remember – your safety and safety of other road users, environmental conditions, as well as ensuring of high performance and your vehicle life period specified by the manufacturer depend on its technical serviceability and observance of operation rules set forth in this manual and the vehicle log book!

The headings «**Warning**» and «**Attention**» inform you about the conditions that can lead to personal injury or damage to your vehicle. The heading «**Warning**» means that irregular actions might result in personal injury, «**Attention**» – irregular actions might result in damage to your vehicle.

The vehicle design is constantly being improved, so separate parts and assemblies, as well as design variants and complete equipment may differ slightly

from those described in the manual. For more information about your vehicle, please contact your vendor.

Do not switch off the speed sensor and do not change data on operational kilometres in the odometer readings without an authorization as it will result in the loss of the manufacturer's warranty and possible failure of the vehicle.

In case of faults affecting traffic safety, under which it is prohibited to operate the vehicle, use service of vehicle carrier.

VEHICLE DESCRIPTION

I. BODY AND PASSENGER COMPARTMENT

KEYS

Two ignition keys (Fig. 1a) with special encoders built in the key head, are attached to the vehicle. The ignition switch key with a black mark on the end combines the functions of:

- the key for door and trunk lid locks;
- the ignition switch key;
- the immobilizer working key*.

In the design variant, instead of the ignition switch key with black mark on the end, the key with remote control (Fig. 1b) that also performs

* The immobilizer blocks the engine start and provides the additional protection against the vehicle unauthorized use. Remember that the immobilizer is only an additional barrier to illegal intruder and does not provide an absolute and complete protection of your vehicle against unauthorized use.



Fig. 1a. Vehicle keys

all above specified functions, is attached to the vehicle.

The key with the red mark combines the functions of:

- the key for door and trunk lid locks;
- the ignition switch key;
- the immobilizer training key.

The key number is written on the label. Remove and keep the label. According to this number, it is possible to make a new key – contact any certified SSNE.

The new ignition switch keys cutting instead of the lost ones is made at the consumer expense.

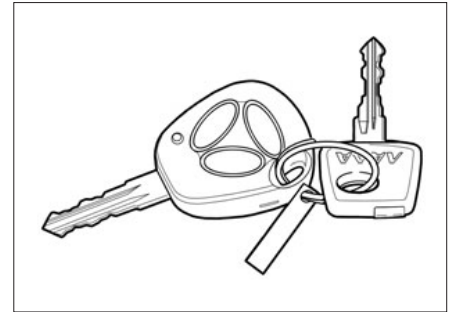

Fig. 1b. Vehicle keys (in the design variant)

ATTENTION!

The ignition switch key with the red mark on the end should be stored separately and must not be carried in one bunch with the working key. It should be used only if the working key has been lost.

REMOTE CONTROL SYSTEM (in the design variant)

The power pack remote control system is designed for:

- remote locking (unlocking) of door locks with the vehicle protection mode parallel activation (disabling);
- all door locks locking by turning the key in the driver's door lock;
- all door locks locking (unblocking) by the key from the vehicle passenger compartment;
- alarm system activation during violation of the vehicle protection zones;
- alarm system remote control disabling or after ignition starting with the key.

For operation it is necessary to activate (train) the remote control panel (Fig. 2) in the vehicle composition by using the training code key (see Section «Immobilizer»). After training, the remote control panel is also an immobilizer working code key and serves to unlock the engine start inhibit mode. System training and operation of the system can be carried out simultaneously with 4 remote controls.

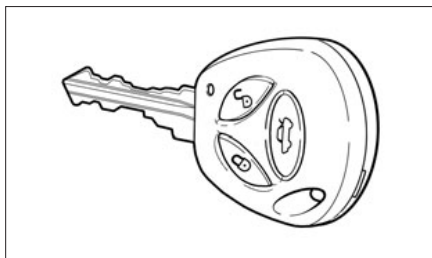



Fig. 2. Remote control panel

ATTENTION!

Selling of the vehicle equipped with remote control system, without remote control panel training, is not allowed. The remote control panel training procedure must be carried out at the vehicle pre-sales training points or at the certified SSNEs in the vehicle owner obligatory presence. In case the vehicle owner refuses to carry out this procedure, the relative record must be recorded in the vehicle log book signed by the sales dealer, affixed with the company's seal and the owner attesting signature. No claims for remote control system operation quality are accepted, if the vehicle owner of the vehicle loses the training code key.

REMOTE CONTROL SYSTEM OPERATION

1. Door locks locking and protection mode activation (*in the design variant*) with the help of remote control panel.

For locking the door locks and the protection mode activation, press the lock button  on the panel. At that, the locks of the side doors will be locked, in parallel the protection mode will be activated, which is confirmed by single flashing of turn indicators and slow flashing of immobilizer state LED  in the instrument cluster.

In case upon the protection mode activation, any door, bonnet or trunk compartment is open (*in the design variant*), the turn indicators will blink three times and a single beep will be emitted. In order to include open zones into the protection zone, close them. The system similar behaviour will be exercise in case of the side doors locks overheat control tripping, if the locks locking (unlocking) occurs time and time again during short intervals. In such case wait for some time, after that the system operability will be fully restored.

2. Door locks unlocking and protection mode disabling with the help of remote control panel.

Door locks unlocking with the help of remote control panel is possible in two modes:



- step by step unlocking (factory supply);
- simultaneous unlocking (particular procedure execution is required – see below).

To unlock the driver's door lock with the help of remote control panel in the step by step unlocking mode press the unlock push-button  on the panel. The driver's door lock will be unlocked and the protection mode disabling is accompanied by the double blinking of turn indicators.

To unlock the passenger doors press the unlock push-button  on the panel once again.

In the simultaneous unlocking mode, during the first pressing on the push-button all vehicle doors simultaneous unlocking occurs.

The unlocking mode change is performed according to the following procedure:

- switch on the ignition with the key on the panel;
- press the lock  and unlock 

push-buttons on the panel simultaneously and hold them for about five seconds;

- after the buzzer beeps release the push-buttons.

If the buzzer emitted one beep, it means that the simultaneous mode of unlocking the doors is set, and if the buzzer gave two beeps, then the step-by-step mode of unlocking the doors is set. During every unlocking mode change procedure it is changed for the one contrary to set before that.

In case after the doors unlocking and the protection mode disabling, no door or trunk lid is open and the ignition does not switch on, then after a certain time (about 25 seconds) the doors will be locked again and the system will switch to the protection mode automatically. The system automatic switching to the protection mode along with the doors locking is followed by the immobilizer LED frequent blinking  in the instrument cluster.

Warning

When holding the lock push-button  on the remote control panel in depressed position for more than 3 seconds, the rolling up of the pulled down door win-

dows is carried out in the following sequence: first, the driver's and the front passenger windows are rolled up, then the passenger rear door windows are.

When holding the unlock push-button  on the remote control panel in depressed position for more than 3 seconds, the rolling down of the door windows is carried out in the following sequence: first, the driver's and the front passenger's windows are rolled down, then the passenger rear door windows are.

When rolling the windows up and down with the help of the panel, beware that in this mode the panel operates in the area of short range from the vehicle. This is due to safety and protection issues against any window accidental pinching of the passengers remaining in the interior.

3. Opening of the trunk lid lock with the help of the remote control panel (in the design variant).

Unlocking of the trunk lid lock with the help of the remote control panel is only possible when the ignition is off. To open the trunk lid, press twice within the short interval or for some time press and hold the push-button



on the remote control panel.

With protection mode on, opening of the trunk lid occurs simultaneously with this protection zone disabling in about 25 seconds. If in the meantime the trunk lid was not opened, this zone is included in the protection zone automatically. In case within 25 seconds the trunk lid was opened, this zone is switched off for all time until it is closed. To close the trunk lid it should be clapped again.

4. Central locking and unlocking of the passenger compartment doors (in the design variant).

To lock all vehicle passenger compartment door locks sunk the driver's door lock push-button or (in the design variant) press the lock push-button  in the driver's door module.

To unlock the driver's door lock from the vehicle passenger compartment pull up the unlock push-button in the driver's door. To unlock all doors (in the design variant) press the unlock push-button  in the driver's door module.

The central locking provides the door locks protection against overheating. If the locking or unlocking of locks occurs during the short time

interval, the system stops responding to the push-button pressing. If this has happened, do not press the push-button for a while, where after the system operability will be fully restored. For the sake of safety the last executed command is always an unlock command.

5. Central locking of door locks from the vehicle outside.

To lock all door locks from the vehicle outside turn the key in the driver's door in the clockwise direction. To unlock all door locks from the vehicle outside turn the key in the driver's door in the counter-clockwise direction.

Unlocking of all doors is carried out by double pressing the unlock push-button on the remote control panel.

ATTENTION!

When it is necessary to lock or unlock the side doors mechanically (for example, for lack of power supply in the vehicle on-board system) one should do the following:

– to lock the front door lock sunk the lock push-button mechanically or by turning the

key from the vehicle outside; to unlock the lock pull out the lock push-button mechanically or by turning the key from the vehicle outside (locking/unlocking of the front door locks is possible only when the doors are closed);

– to lock the rear doors lock sunk the lock push-button mechanically (locking/unlocking of the front door locks is possible either when the doors are closed or open).

6. System operation in the protection mode

After protection mode activation the system monitors the state of the following protection zones:

- side doors;
- bonnet;
- trunk lid;
- ignition switch key;
- driver's door lock;
- storage battery voltage.

If in the protection mode any of the following actions occurs:

- any side door opening;
- bonnet opening;
- trunk opening;
- ignition starting without using the «native» key;
- driver's door unlocking;

– storage battery connection after its disconnection,

the alarm system is activated in the form of light signaling with the help of turn indicators and of sound signalling with the help of the vehicle standard alarm horn for about 30 seconds.

Single pressing of any button on the panel when the system is in the alarm mode, results in turning off the alarm signals, but, at that, the system still remains in the protection mode. The protection mode disabling occurs after pressing the unlock push-button on the panel.

7. Key code re-synchronization.

In case of pressing the panel push-button beyond the reach of the radio channel, «floating» code counter in the panel goes out of synchronization with the counter in the system control unit. If the number of push-button pressings on the panel beyond the signal detection range exceeded 1000, the system stops responding to the panel commands. In this case, the procedure of the panel re-training should be provided at any certified SSNE.

IMMOBILIZER

The electronic immobilizer (implemented in the instrument cluster), providing their additional protection against unauthorized use by blocking the engine start, is applied for Granta family vehicles.

Granta family vehicles are completed with two ignition switch keys (see Section «Keys»).

One ignition switch key with the black mark on the end or with the remote control panel (*in the design variant*) is a working key. It is used for unlocking the engine start inhibit mode. This key is recommended to use for everyday trips.

The second ignition switch key with a red mark on the end is a training key. It is used for unlocking the engine start inhibit mode, as well as for activating (training, re-training) immobilizer and (*in the design variant*) for the remote control system of doors' locking (unlocking).

It is possible to train and operate the immobilizer with one to 4 working keys.

ATTENTION!

Selling any vehicle equipped with an immobilizer without its activation is not allowed. The

immobilizer activation procedure should be carried out at the vehicle pre-sales training points or at the certified SSNEs in the vehicle owner obligatory presence. In case the vehicle owner refuses to carry out this procedure, the relative record must be recorded in the vehicle log book signed by the sales dealer, affixed with the company's seal and the owner attesting signature.

Due to the training key importance it is not recommended to use the ignition key with the red mark for daily trips. If required, it should be kept in a safe place. If you lose the training key, the warranty liabilities as regards the immobilizer, the engine controller and the driver's door module (*in the design variant*) are not accepted.

It is not allowed to install the alarm system, the protection and other additional electrical and electronic devices by cutting and twisting wires (without standard pads use) or by passing the standard control unit for the doors locking. The failures of the door locking gear reducer, gear reducer control unit, body electronics

main unit (*in the design variant*) due to improper connection of additional devices are not covered by the factory warranty.

The immobilizer has an signal indicator  and an alarm sounder (a buzzer) in the instrument cluster.

The signal indicator  demonstrates the immobilizer state:

– if after ignition activation the signal indicator does not flash or blink, it means that the immobilizer is operable, and the engine start-up is allowed;

– if after the ignition activation the signal indicator flashes for approximately 15 seconds and then goes down, it means that the immobilizer is not activated and the engine start inhibit mode does not function, so, to activate the immobilizer you should contact any certified SSNE;

– if after ignition activation the signal indicator blinks, it means that the immobilizer is faulty. The immobilizer failure is additionally diagnosed with short buzzer beeps. To rectify the defect you should contact any certified SSNE.

ATTENTION!

To ensure stable reading of the ignition switch key code with the

immobilizer, do not attach two or more ignition switch keys to one ring.

The ignition disabling by the training key results in the immobilizer signal indicator blinking which is not indicative of the failure.

DOORS

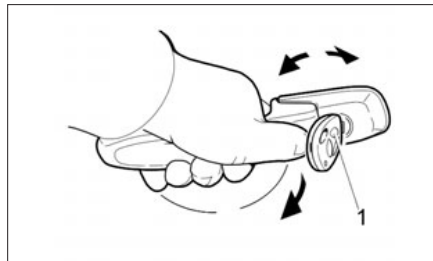



Fig. 3. Opening the door

The front doors are locked: from outside – with Key 1 (Fig. 3) or (*in the design variant*) with the remote control pane; from inside – by pressing the lock push-button 1 («by depression») (Fig. 4a, 5a) in the door or (*in the design variant*) with the push-button  in the driver's door module (Fig. 6b). To lock the lock is possible with the doors closed.

The push-button  in the driver's door module (*in the design variant*) is intended for the vehicle doors simultaneous locking or unlocking. During pressing this push-button the change of the door lock status occurs. For example, if the

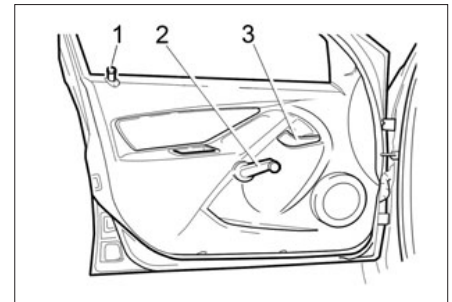

Fig. 4a. Left hand front door

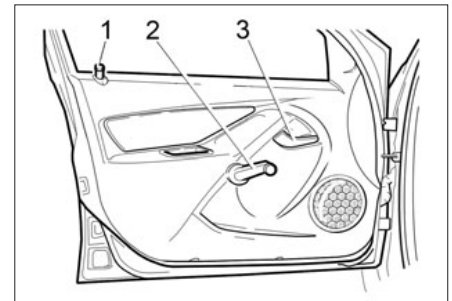

Fig. 4b. Left hand front door with the speaker
(*in the design variant*)

vehicle doors were unlocked, after pressing this key the doors become locked, and vice versa.

The doors are opened: from outside – with the handle in the arrow direction, and from inside – by turning over internal handle 3 to yourself. If the door lock is locked, the handle would have idle stroke.

For rolling down and rolling up the front door windows, the manual glass windows operated by the winders 2 are used.

If the winder is absent (*in the design variant*) the power windows can be used. To roll up the proper window just pull the relative power window switch upwards (Fig. 6a). To roll down the proper window, press down the edge of the relative power window switch. After de-pressing the push-button is automatically set to the middle position, and the window will be stopped at any position you have selected.

Driver's door module

The driver's door module (DDM) switches assignment is as shown in Fig. 6b:

1 – switch (joystick) for electrical-ly operated side mirrors control in the lateral and vertical directions;

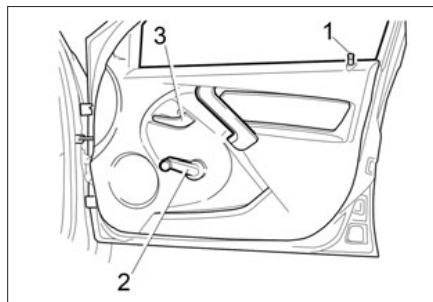
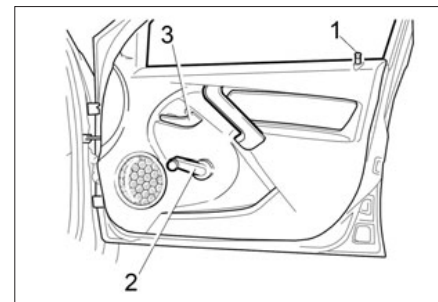

Fig. 5a. Right hand front door



**Fig. 5b. Right hand front door with the speaker
(in the design variant)**

2, 3 – selection of the mirror for control (right hand or left hand);

4-7 – window regulator control key-buttons (corresponding to the location of windows in the vehicle);

8 – push-button for locking or unlocking all vehicle door locks;

9 – push-button for rear power windows On and OFF operation.

To control the mirrors it is necessary to switch on the ignition and press the appropriate push-button for mirror selection. Select **2** (👤) button – if you need to control the left hand mirror, or select **3** (👤) button – to control the right hand mirror. When

pressing the button its letter symbol will highlight with orange for some time, it means that you can control the selected mirror. If the highlight goes down, it means that the mirror control was stopped, if necessary, press the button again. After the ignition switching off you can still control the mirror for about 90 seconds, if no door has been opened. In any case, the mirrors control is possible only when **2 or 3 button highlights**.

To control mirror position, use joystick 1. Achieve the desired mirror position by pressing one of the ticks by turn.

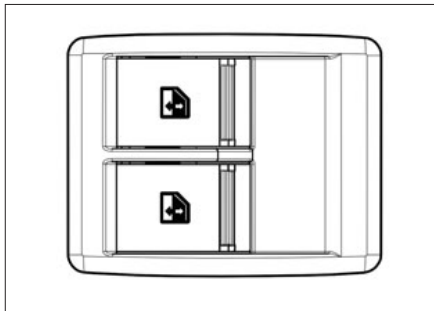

**Fig. 6a. Switch pack
(in the design variant)**

You can control the electric power windows with the key-buttons located in DDM and in the passengers' doors. Power window control key-buttons have 3 positions:

1. «Rolling the window up» (non fixed end position).
2. «Off» (fixed centre position).
3. «Rolling the window down» (non-fixed end position).

To roll down the window, press the button, to roll up the window – pull up the button.

The power windows operation is allowed:

- as long as the ignition is switched on;

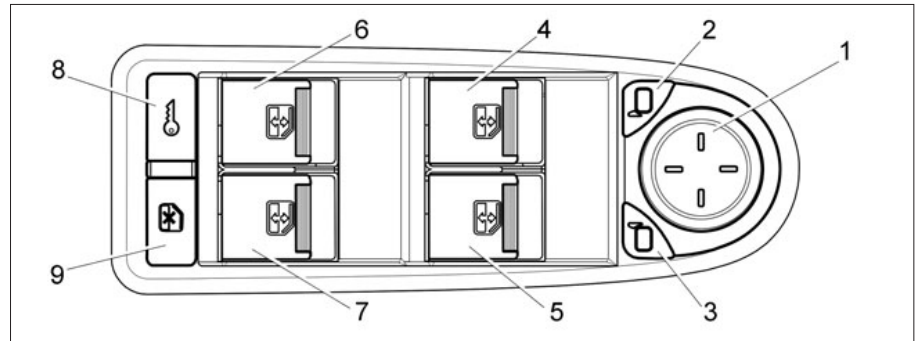





Fig. 6b. Driver's door module (in the design variant)

– within 30 seconds after switching off the ignition, if during this period none of the front doors has been opened.

The window regulators operation by the control buttons in the doors stops when the ignition is off, after opening any front door or after switching on the protection mode.

The window regulators operation with the ignition off and with the open door is possible only with the help of the remote control panel (see Section «Remote control system»).

In the design variant, when the ignition is switched off, the power

windows are additionally controlled with the push-buttons  and  of the remote control panel. The window rolling up occurs during retaining the button  in depressed position for more than three seconds. First, the front door windows, then **(in the variant position)** the rear door windows are rolled up. The window rolling down occurs when retaining the button  in the depressed position for more than three seconds. First, the front door windows, then **(in the variant position)** the rear door windows are rolled down.

The windows automatic rolling up/down with the help of DDM key-buttons*.

When pressing the driver's window control button operating in the rolling up/down mode for no more than 1.5 seconds, then, after releasing it, the window stops. If this application time exceeds 1.5 seconds, then the window will continue to move automatically until it detects the obstruction (see the relevant Section), but for no longer than 10 seconds.

To control front passenger's door right hand window with DDM key-button, the automatic rolling down mode is implemented, which works similar to the driver's door window rolling down mode.

The windows automatic rolling up/down mode terminates when rolling up against the stop or recognizing an obstruction and/or when pressing any window regulator control button on the DDM.

Rolling up/down windows with the

button in the passenger's door is similar to the DDM buttons operation with the following restrictions:

- only that door window is controlled where the key-button is located;
- it is impossible to control with the button in the passenger's door as long as you control the same or the other window of the same side board with DDM;
- it is impossible to control with the rear passenger's doors buttons if the inhibit mode on their operation is enabled (see below).

In order to disconnect the power window control from the switches, located in the rear doors (*in the design variant*), you should press the button 9 on the DDM, thereupon, the letter symbol will highlight orange. To resume the power window control with switches located in the rear doors, you should press button 9 on the DDM again. At that, the orange highlight of the button letter symbol will go down. The rear door

key-button operation inhibit mode is maintained after the ignition switching off/on and the power supply system connection/disconnection.

It is possible to control simultaneously two power windows, located on different sides of the vehicle.

Obstruction recognition

The system operates the obstruction recognition mechanism when rolling the window. In case of an obstruction detection the window stops until next controlling action arrival.

In case the controlling actions on one and the same power window in the same direction follow more often than one in every 5 seconds, the obstruction recognition mechanism becomes less sensitive, pending to its overall switch-off. The obstruction recognition mechanism enabling occurs in 5 seconds after the last controlling action.

Warning

During windows closing with power windows fingers and other body parts pinching is possible

* The automatic mode of the window rolling up/down is initially implemented in the factory delivery of the DDM. The window regulator automatic control mode disabling is possible with the help of the diagnostic tester at the certified SSNEs.

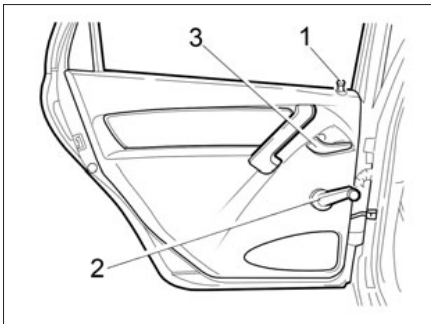

Fig. 7a. Rear door

which could result in serious injury. Therefore, when using power windows, be careful especially if there are children in your vehicle or next to it. Make sure that **Beware that the rolling up window does not pinch anything. In case of pinching, stop the window rolling up immediately and switch on rolling it down.**

The vehicle driver bears responsibility for improper use of power windows. He should explain the rules of use to the passengers and warn them of dangers in case of improper use of the power windows.

Do not allow the children to use the power window switches!

Getting out of the car, be sure to remove the key from the ignition switch to turn off the power windows and avoid accidental injury. The immobilizer buzzer of the gives a beep as a warning that ignition key was left in the lock, when the driver's door is opened. There would also sound a trill but in the other tone, if the ignition key was removed but the tail lights were left switched on.

Do not thrust hands and other body parts out of the vehicle open windows, make sure that the children do not do it.

The rear doors are locked from inside the compartment by pressing the locking button 1 («by depression») (Fig. 7a) as with the open, so with the closed door.

For rolling down and rolling up the front door windows, the manual glass windows operated by the winder 2 are used.

When the winder is absent (*in the design variant*) use windows are used (see above).

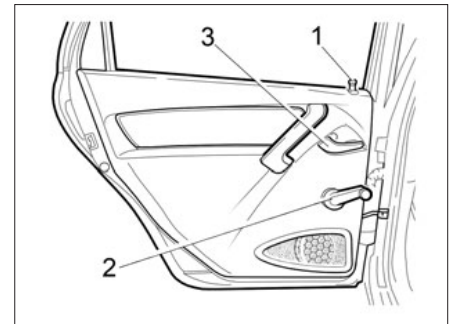

Fig. 7b. Rear door with the speaker (in the design variant)

The rear door window is rolled down to full extent.

If there are the children in the rear seat, be sure to turn the latch hook spline 1 with the key (Fig. 8) approx. for 45° up to stop. At that, you should turn the latch hook clockwise in the right hand door, and counter-clockwise in the left hand door. In this case, with the lock button pulled up, the door is opened only from the outside and the internal handle has free travel. To provide opening the doors from inside, turn the latch hook spline in the opposite direction.

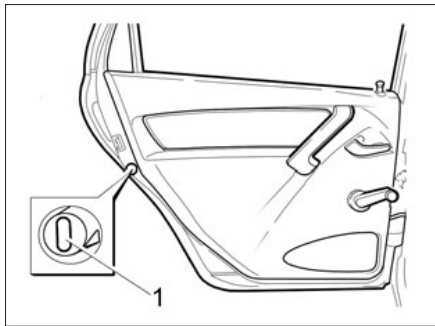

Fig. 8. Latch hook spline

FOOT PEDALS LOCATION AREA

Foot pedals

When operating accelerator, brake and clutch pedals (see Fig. 28, items 18, 19 and 20), nothing should interfere with their full stroke.

Use only such mats on the floor, which do not interfere with pedal normal operation, and they can be fastened securely.

ATTENTION!

Do not put any objects on the floor in front of and under the driver's seat. While braking the

object may fall in the pedals location area and interfere with their normal operation. When it is necessary to prevent a collision or make a quick manoeuvre, and you will not be able to brake immediately, depress the clutch or accelerate.

Shoes for driving the vehicle

Wear the shoes that fit your feet and let you drive the vehicle with confidence and at ease.

SEATS

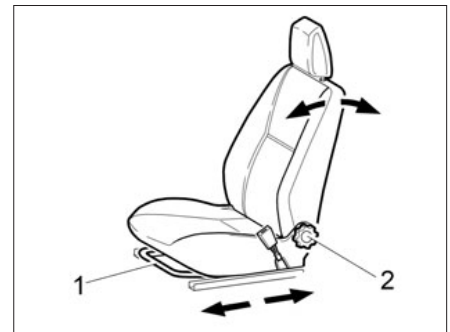

Fig. 9. Front seat

Front seats. To adjust the front seats in the longitudinal direction, pull the locking lever 1 (Fig. 9) upwards. After installing the seat in a comfortable position pull the lever down, and, by a slight shifting movement of the seat back and forth, reach its reliable fixation.

Warning

Never adjust the driver's seat while driving the vehicle. The seat may abruptly move out of its location, which would result in the loss of the vehicle control.

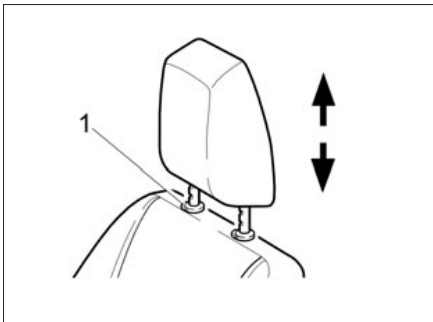

Fig. 10. Headrest

The seat back tilt is adjusted by handle 2 stepless rotation.

In the design variant, the front seats are equipped with the electric heaters that are switched on with switch 15 (see Fig. 28), when the engine is running. To enable the left hand seat heating press the left switch; to enable the right hand seat heating press the right switch. The heating disabling is performed by re-pressing the switch.

The check light signal indicator located on the switch key-button will glow orange for the duration of the heater operation.

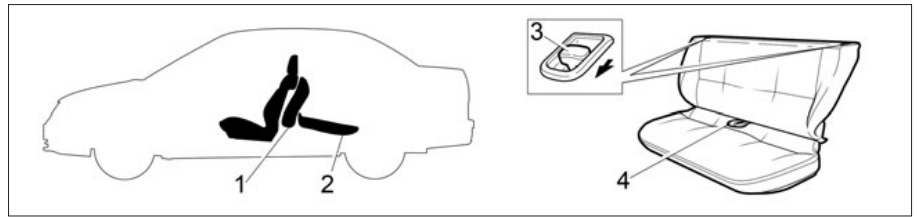
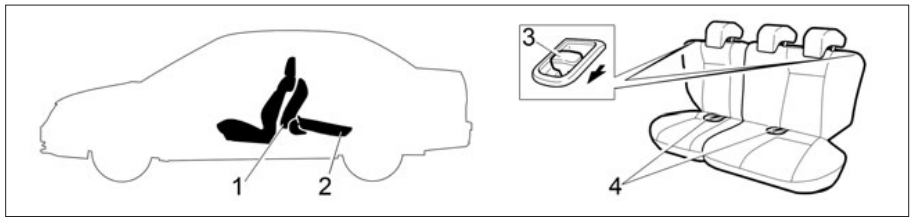

Fig. 11a. Folding the rear seat down



**Fig. 11b. Folding down the rear seat with the headrests
(in the design variant)**

The headrest (Fig. 10) height adjustment is carried out by applying direct action on the headrest. The adjustment down is performed by pressing the headrest stop lever 1 from the right side. To remove the headrest from the seat back, shift the headrest to its highest position and press its lock lever from the right side.

The optimum headrest position is when its top edge is on the same level with the top of the head. In case it is unattainable, for very tall people, it is necessary to raise the headrest to its highest position, and for very short people – to its lowest position.

Rear seats. To expand luggage compartment area, the back seat folding down option is provided.

Before the back seat (or its part) folding up it is necessary to install the safe belt locks into the seat belt holders in the seat back bottom part. When the seat back return to its operating position make sure that the shoulder branches of side belts have not fallen behind the back. After the seat back return to its operating position the belt locks must be removed from the seat belt holders.

Warning

Do not allow the seat belts location behind the seat back when you return it to the operating position to provide their future intended use and to avoid the belt bands damage with the seat back lock.

The rear seat folding down should be carried out in the following sequence:

- pull the strap 4 (Fig. 11a, Fig. 11b) and set the seat cushion 1 to the vertical position. Move the front seats forward, if necessary;
- pull the lock drive lever 3 and fold down the back 2 to the horizontal position.

Setting the rear seat to its normal position must be carried out in the reverse order.

In the design variant, each of two seat parts can be folded down separately, if necessary. During folding up of any rear seat part for goods transportation, only one passenger can be placed in the remaining part.

**STEERING WHEEL POSITION ADJUSTMENT
(in the design variant)**

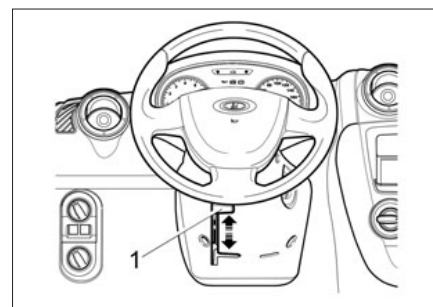

**Fig. 12. Steering wheel position adjustment
(in the design variant)**

In the design variant, the vehicle is equipped with the tilt steering column. For selection of the optimum steering wheel position, pull down locking handle 1 (Fig. 12) and, after setting the steering wheel to the desired position, fix the steering column by moving the handle to its highest position.

Warning

Steering column adjustment must be carried out only in the stationary vehicle.



Fig. 13. Pulling the seat belt out

SEAT BELTS

Seat belts are effective for the driver and passengers protection against serious consequences of road traffic accidents (RTA).

To fasten the belt, pull it out smoothly, holding the belt tongue (Fig. 13), and insert tongue 2 (Fig. 14a) into lock 1 until it clicks, meanwhile, avoid twisting the bands. Make sure that the lower belt strap fits tight against your hips. It is not allowed to pass the belt lower band around the waist or under the hips. To unfasten the belt press the lock red button, the belt will be pulled into the reel automatically. If the belt band pulling in is

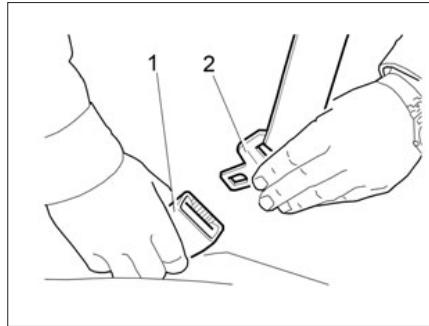

Fig. 14a. Fastening the seat belt

not efficient enough, then, holding belt tongue 2 in hand, find the belt band position in which it completely returns into the reel.

ATTENTION!

It is not allowed to leave the vehicle without making sure that the belt has been fully returned to its initial position, to prevent the band from being pulled out with you and avoid inflicting damage to it when closing the vehicle doors. In such case the seat belt may become inapplicable for further operation.

In the design variant, the front seat belts are adjusted according to

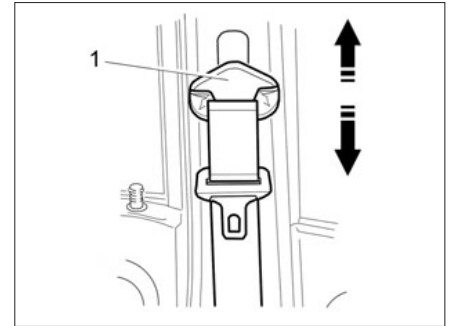

Fig. 14b. Adjusting the seat belt (in the design variant)



Fig. 14c. Mini-lock of the back middle seat passenger seat belt

up/down position of the top attachment point. Slightly pulling the belt out, adjust its height so that it is located as high as possible, but does not contact with your neck and does not put pressure on your shoulder. To adjust the belt, press the decorative moulding 1 (Fig. 14b) against the side column and, and moving it, select one of five fixed up/down positions of the top attachment point.

In the design variant the vehicle is equipped with front seat belts with pretension and the load limiter located in the front seat belts. The front seat belt tensioners are designed to select a possible band slackness for the driver and front passenger seats during frontal collision. The load limiter is designed to reduce maximum retention force of the driver and the front passenger during frontal collision.

The back seat passengers fasten their seat belts similar to the front ones.

The pregnant women should always use lap and shoulder belts, if the doctor approves them. The belt lap part should be as low and comfortable as possible.

Warning

When driving be sure to fasten your seat belt and not to carry the

passengers with unfastened seat belts!

The pregnant women should never put the belt lower band on the abdominal region, where the fetus is located, or above the abdomen!

If the belt tugs are dirty, clean them with soft soap solution. Do not iron the belt bands! The belt must be replaced with the new one if it was subject to critical load during the road traffic accident or has scuffs, ruptures and other damages.

The pre-tensioners are actuated regardless of whether the seat belt is fastened in the lock or not.

Unauthorized interference with the front seat belt pre-tensioners and load limiters is not allowed. All relative operations should be performed only at the certified SSNEs by the specially trained personnel.

When fastening the seat belts be sure to adhere to this Manual instructions (do not place the belt diagonal part behind your back or the seat back, do not place the lower part of the belt under the hips or the seat cushion, etc.).

AIR BAGS

The vehicle is equipped with frontal Driver Air Bag System (DABS), **in the design variant** with the front passenger Air Bag System, with the side air bags of the driver and the front passenger and front seat belts with the pre-tensioner and the load limiter. When actuating, the ABS in a very short space of time, the front seat belts are pulled in to secure the driver and the passenger reliably and the air bags are filled up with gas, so that, when being opened, to reduce the risk of inflicting injury to the driver and the front passenger upper body and head. The ABS are actuated during the vehicle frontal or side collisions, when it is necessary to enhance the driver and the front passenger safety.

The available ABS is marked with the AIRBAG sign on the steer wheel cover, with the SRS AIRBAG sign on the instrument panel cover and the AIRBAG sign on the seat belt.

The ABS includes:

- the driver's air bag module built in the steering wheel;
- the air bag module, located in the instrument panel above the glove box;

- the air bag modules in the front seats;
- the seat belts with the pre-tensioner and the load limiter;
- the rotating device mounted on the connector of under-steering switch (for connection of the buzzer stop switch and the air bag module with the vehicle circuit);
- the ABS control and diagnostic unit mounted on the body floor tunnel under the console of instrument panel;
- ABS diagnostics indicator in the instrument cluster.

The air bags are the additional means of protection for the driver and the front seat passenger fastened with the seat belts, and are actuated during hard frontal or side collision:

- starting with the specific severity of collision;
- in the coverage areas shown in Figure 15a.

The ABS must get actuated in case of the severe frontal impacts and the side collision. However, the ABS may also get actuated in other emergency situations, if the vehicle experiences the impacts similar to those to which it is subject during the

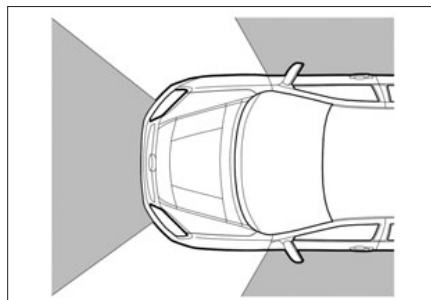

Fig. 15a. ABS coverage and actuating zone (highlighted in colours)

severe frontal impact or the side collision.

Examples for the ABS actuating situations (Fig. 15b):

- collision with stationary non-deformable obstruction: the air bag may be actuated at low speed;
- collision with non-fixed deformable obstruction (for example, with another vehicle): air bag may be actuated at the vehicle high speed;
- in case of the ample force impact affecting the vehicle in front, some examples are shown in Figure 15b.

The ABS are not actuated during:

- ignition switched off;
- imperceptible frontal and side collisions;

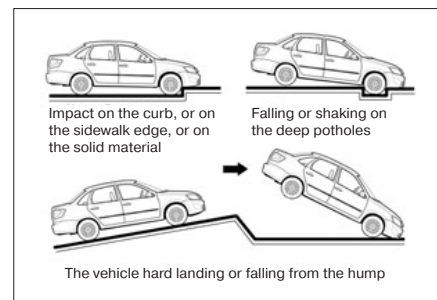

Fig. 15b. Examples of the ABS actuating situations

- vehicle roll-over;
- vehicle side ward impact (*in the design variant* with no air bags) or vehicle rearward impacts, i.e. in cases, where the system can enhance to safety.

The degree of damage to the vehicle body during collision (or absence of serious damage) is not always an indicator of the front air bags normal or abnormal operation.

During the air bag deployment the danger of visibility restriction for the driver is virtually absent, as the air bag is filled and emptied in a short period of time.

The air bag provides optimum protection under correct setting of

the position of the seat, the seat back and the headrest. All the back should rest on the seat back and the seat should be moved back as far as it is practically possible for the driver, so that staying in the upright sitting position with his arms bent in elbows, he could hold the steering wheel. The passenger's front seat should be moved back to the maximum and set to the vertical position lest that he did not experience inconvenience and discomfort. In the event of air bag deployment the improper sitting position can result in serious injury or death. The air bag needs space for filling it with gas.

The ABS is a single-use self-contained unit and requires no maintenance during the vehicle operation. After the ABS actuating the control unit and the air bag modules, the seat belts with the pre-tensioner are subject to mandatory replacement at the service and sales network enterprise (SSNE).

ATTENTION!

1. The air bag does not replace the seat belt, it only complements to its operation, thus you should always fasten the seat belts.

Those who do not use the seat belts, run the risk of suffering more severe injuries or even being thrown out of the vehicle during road traffic accidents, at that, the fatal outcome possibility cannot be eliminated. During the road traffic accident, the belt helps to ensure that you take the safest sitting position in which the air bag can provide the most effective protection.

2. Do not attach any objects to the steering wheel and the instrument panel, because they can cause injuries during the air bag deployment. The same danger also exists in cases when the driver or the passenger smokes a pipe or uses a mobile phone while driving.

3. When driving, do not put your forearms/palms to the location where the air bag is mounted.

4. When driving the front seat passenger must not rest on the instrument panel and hold any objects that may cause injury during ABS actuating.

5. The ABS diagnostics indicator must be switched on for 3-4 seconds after switching the ignition and then be switched off. The

subsequent diagnostics indicator actuation in the process of the vehicle operation means that a fault in the ABS has been detected, that's why its actuating during frontal collision is not guaranteed.

6. Unauthorized interference with the ABS operation is not allowed. All relative operations should be performed only at the certified SSNEs by the specially trained personnel.

7. Immediately after the air bag actuating, some system elements may have high temperature. To avoid the burns, do not touch the hot parts.

8. The skin surfaces with appearance of signs of irritation, should be thoroughly washed with soap solution. If eye irritation, wash them with clean water. In case of prolonged troubles consult a doctor.

9. With scrappage the vehicle be sure to dismantle the ABS components at the SSNE.

In the design variant the side air bags are installed in the front seats.

The side air bags are designed to provide additional protection for the driver and/or the front seat passen-

ger in the event of the side collision (in addition to the protection provided by the seat belts).

The side air bags do not deploy during all side impacts; they deploy only during those side impacts that pose hazard to the driver and the passengers.

Warning

Do not allow the passengers to lean out of the doors, put any objects between the doors and the passengers, if they are sitting on the seats equipped with the side air bags.

The side air bag is used in addition to the driver and passenger seat belts and does not abandon their need for use. Therefore, always use seat belts during driving. The air bags are deployed only under certain side impacts, posing hazards to safety of people sitting in the passenger compartment.

To ensure the best protection against the side impact and to prevent the injuries as a result of the side air bag actuating, the driver and the front seat passenger should sit straight and be

properly fastened with the seat belts. The driver should keep his hands on the steering wheel in the strict left and right direction positions. The passenger should keep hands and arms on his/her hips.

Do not put any additional covers on the seats. The use of covers can reduce the system efficiency down to zero.

Do not install any accessories on the sides of the passenger compartment or near the side air bags.

Do not place any objects on top of the air bag or between that and yourself.

Do not place any objects (an umbrella, a bag, etc.) between the front door and the front seat. Such objects can become dangerous and cause injury in the event of the side air bag actuating.

To prevent the unexpected side air bag deployment that can lead to an injury, avoid impacts against the side impact sensor, located in the centre column, with the ignition on.

In case the seat or its upholstery is damaged you should contact any certified SSNE.

Any seat disassembling and any seat design change and the interior trim elements are not allowed, excluding performance of these operations by the qualified personnel at the certified SSNE.

INSTALLATION OF CHILD RESTRAINTS

In your vehicles are used standard seat belts of adult passengers to fasten child restraints.

Save placement of children in vehicle is only possible using child restraints, that meet the requirements of European standard ECE R44.

Choosing child restraint system is necessary to use information, given in the Table 1 «Scheme of installation child restraints».

Installation and operation of child restraint must be realized in accordance with manufacturer' instruction for child restraints.

Warning

1. Do not use child restraint on the right front seat, where child seats facing upstream movement. Right front seat is protected by active airbag.

2. Do not keep the child on your knees while driving.

3. The most safety transportation of children under the age 12 is on the back seat, using child restraint, according to the age and weight of child.

Table 1
Scheme of child restraints installation

Weight of child	Type of child seat	Seats in vehicle			
		front passenger seat		rear seats of passengers	
		without airbag	with airbag	side	middle
Category «0» < 10 kg (approximately 0-6 months)	Transverse cradle	X	X	U	X
Category «0+» < 13 kg (approximately 6-18 months)	Rear-facing seat	U	X	U	U
Category «1» 9-18 kg (approximately 9 months – 3,5 years)	Rear-facing seat	U	X	U	U
	Seat, adjustable in the direction of movement	UF	UF	UF	UF
Category «2» 15-25 kg (approximately 3,5...6 years)	Seat, adjustable in the direction of movement	UF	UF	UF	UF
Category «3» 22-36 kg (approximately 6...12 years)	Seat, adjustable in the direction of movement	UF	UF	UF	UF

U – place is suitable for installation of «universal» child restraint, with rear-facing installation, and officially approved for this weight category.

UF – place is suitable for «universal» child restraint installed in the direction of movement and officially approved for this weight category.

X – place is not suitable for child restraint installation.

4. Before the installation of child's restraint at the seat of middle back passenger (for model 2191) the seat belt of the back middle passenger should be in a such position when lower tongue is inserted into mini-lock

(Fig. 14 c), further follow the recommendations of the child restraint manufacturer.

Installation of ISOFIX child restraints

Your car is equipped with the ISOFIX system holders allocated on the rear seats, which allow to install the child restraints with ISOFIX holders complying with the requirements of ECE-R44 standard (for children with weight up to 18 kg).

The ISOFIX system consists of two lower ISOFIX holders and upper ISOFIX safety belt holder.

The lower ISOFIX holders with jointed appropriate child ISOFIX restraint holders are allocated in the lower part of the rear seat back.

Their allocation is marked by round signs .

Before ISOFIX child restraints holders joining it is necessary to clear zone of lower ISOFIX holders by placing the rear safety belts locks in the junction line of rear seat cushion and back.



Bracket for upper ISOFIX safety belt signed  and  is allocated on the rear shelf behind the relevant seat (for model 2190) or in the lower part of the rear seat back on the luggage compartment side (for model 2191).

Table 1a

The ISOFIX child restraints Diagram

Weight group	ISOFIX dimensional class	ISOFIX mounting positions in the vehicle		
		rear seat right hand place	central rear seat place* (for model 2190)	rear seat left hand place
«0» (up to 10 kg – about 0-6 months)	F (Baby bassinet)	X	X	X
	G (Baby bassinet)	X	X	X
	E (Rearward-facing seat)	IL**	X	IL**
«0» (up to 13 kg – about 6-18 months)	E (Rearward-facing seat)	IL**	X	IL**
	D (Rearward-facing seat)	X	X	X
	C (Rearward-facing seat)	X	X	X
«I» (9-18 kg – about 9 months – 3,5 years)	D (Rearward-facing seat)	X	X	X
	C (Rearward-facing seat)	X	X	X
	B (Facing front seat)	IUF	IUF	IUF
	B1 (Facing front seat)	IUF	IUF	IUF
	A (Facing front seat)	IUF	IUF	IUF

IUF – a seating space suitable for installation of the ISOFIX «universal» child restraint for this dimensional class.

IL – a seating space suitable for installation of the ISOFIX «semi-universal» child restraint for this dimensional class.

X – a seating space not suitable for installation of the ISOFIX child restraint.

* When installing the ISOFIX child restraint to the central space of rear solid seat the installation of ISOFIX child restraints to the side seating spaces is excluded.

** At the date of publication the recommended child seat of this ISOFIX dimensional class is Britax Romer Baby Safe seat.

After fixation of upper ISOFIX safety cord adjust its tension in accordance with instruction of the child ISOFIX restrainer's manufacturer.

When choosing the ISOFIX child restrainer it is necessary to be guided by the information contained in the Table 1a «THE ISOFIX Child Restrainers Installation Diagram». The ISOFIX child restrainer can be installed in the car only if it complies with the requirements of ECE-R44 standard.

Warning

Make sure that during the installation the ISOFIX child restrainer locks, inbuilt in the ISOFIX restrainer, do not damage the belt band of the back seat.

The ISOFIX child restrainer shall be used in accordance with instruction of the child ISOFIX restrainer's manufacturer.

PASSENGER COMPARTMENT EQUIPMENT

Exterior mirrors

The exterior mirrors are adjusted with handle 1 (Fig. 16). Before driving ensure the optimum rear view.

In the design variant there is no handle 1, and the exterior mirrors are adjusted with the switch 1 (see Fig. 6b) in the driver's door module (see Section «Driver's Door Module»).

In the design variant during the rear window heating activation the exterior mirrors heating is also switched on.

Interior mirror

Rear view interior mirror is adjusted by turning the flex head joint. When being dazzled with headlights of the transport moving behind, change the mirror gradient angle with the help of lever 1 (Fig. 17).

In the design variant the interior mirror without lever 1, with anti-dazzling coating is installed, this mirror gradient angle change is not provided.

Interior ceiling light

Interior ceiling light operation mode (Fig. 18a) depends on switch 1 position:

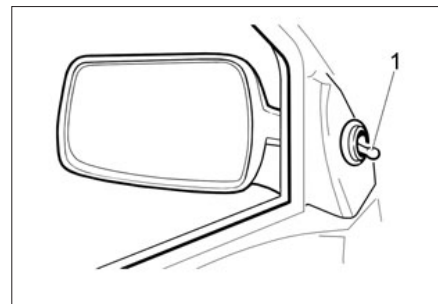

Fig. 16. Exterior mirror

☀ – the ceiling light is on and burns continuously, until it is off.

The ceiling light is off in the switch 1 middle position.

🚪 – the interior ceiling light is switched on and off automatically when opening and closing the driver's door.

In the design variant,

☀ – the ceiling light is on and burns continuously, until it is off.

The ceiling light is off in the switch 1 middle position.

🚪 – with the ignition on, the interior ceiling light is on and off automatically when opening and closing the passengers' doors. With the ignition off, the interior ceiling light is on, if any door is opened. After closing

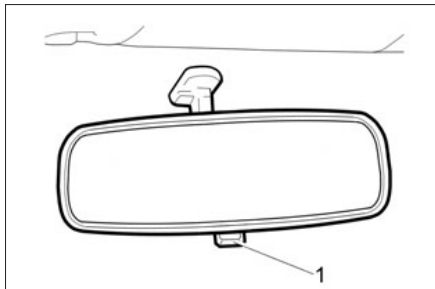

Fig. 17. Interior mirror

all doors the ceiling light goes on illuminating according to the following algorithm:

- After closing the last of the open side doors the ceiling light goes out smoothly within 2 seconds when the ignition is OFF.

- After closing the last of the open side doors the ceiling light goes on glowing within 5...60 seconds - «off-delay» function, where after it goes out smoothly within 2 seconds when the ignition is OFF. The ceiling light off-delay is programmed via the diagnostic interface at the SSNE. Initially, the default delay is 25 seconds.

- If switch on the ignition during the off-delay, the ceiling light will go out smoothly within 2 seconds after switching on the ignition.

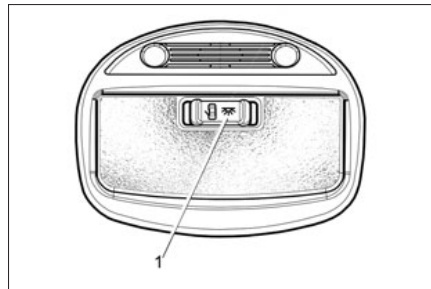

Fig. 18a. Interior roof lighting

- If, during the off-delay, the alarm system protection is being installed, the roof light will go out smoothly within 2 seconds after the protection installation.

- After disabling the protection mode from the remote control panel the ceiling light flashes and glows within the specified off-delay time (see above), in case none of the doors was open.

In the design variant the interior illumination unit instead of the ceiling light is installed (Fig. 18b), which comprises the individual illumination sections for the driver's and front passenger's seats and the general interior illumination section. The left and right sections of individual illumination are switched on/off by press-

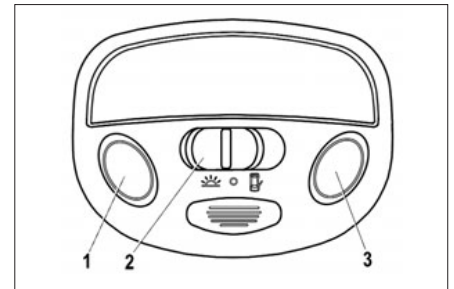

Fig. 18b. Interior illumination unit

ing the left 1 or the right 3 buttons respectively.

The interior illumination unit operation mode depends on switch 2 position:

- ☞ - with the ignition on, the interior general illumination section is switched on and off automatically when opening and closing the passengers' doors.

With the ignition off, the general illumination section is on, if any vehicle doors is open. After closing all doors, the general illumination section goes on burning for about 10 seconds and then goes out smoothly.

- ☞ - the ceiling light is on and burns continuously, until it is off.

- - the general illumination section is off.

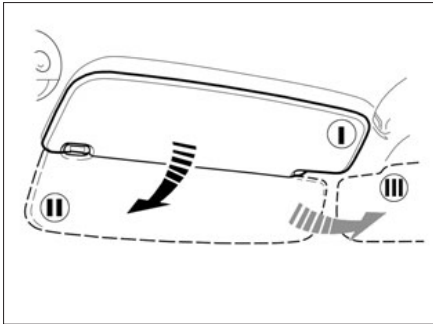

Fig. 19. Sun visor

In the design variant the vehicles are provided with power save function for interior illumination and, during continuous illumination, it switches off their power supply.

When switching the ignition off the time countdown of voltage supply to these devices starts – the power saving circuit delay. The delay value is programmed via the diagnostic interface at the SSNE and may be set from 5 to 40 minutes. Initially, the default delay is 10 seconds. After the delay, the voltage on the listed illumination devices is switched off. After voltage disconnection, you can restart the delay by opening any door or by switching the ignition on and off.

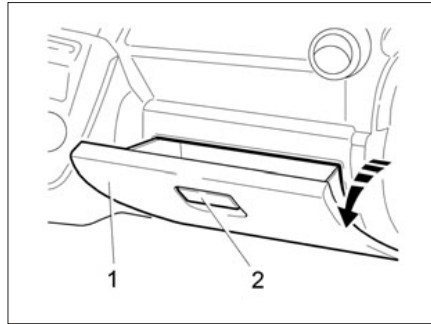

Fig. 20. Glove box

Sun visors

Depending on the direction of sunbeams, the sun visors can be set from position I (Fig. 19) to positions II or III. **In the design variant**, there is a vanity mirror on the inside of the passenger sun visor.

Glove box

To open the glove box cover you should pull the lock key-button 2 (Fig. 20) and then open cover 1.

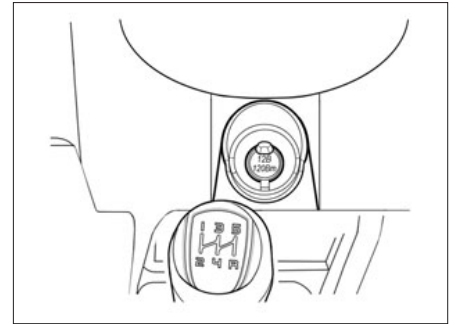

Fig. 21a. Socket for additional electrical equipment connection (in the design variant)

Socket for additional electrical equipment connection

In the design variant, the socket for additional electrical equipment connection (Fig. 21a) is installed in the vehicle that is used for connection of only 12-volt electrical appliances with power output of at most 120 W.

In the design variant, the cigarette lighter (Fig. 21b) instead of the socket is installed in the vehicle for additional electrical equipment connection.

To use the cigarette lighter, press the socket button until it is fixed. In about 20 seconds, the socket auto-

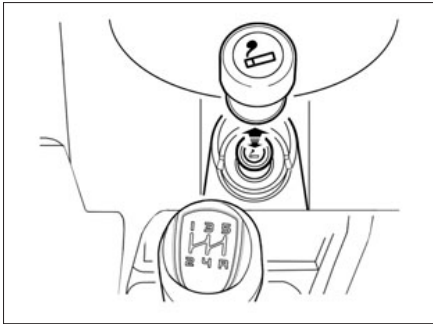

**Fig. 21b. Cigarette lighter
(in the design variant)**

matically returns to its initial position, ready for use.

ATTENTION!

1. Do not hold down the cigarette lighter forcefully for a long time, this can cause its overheating and the spiral burn-out. At that, the cigarette lighter bi-metallic fuse will be actuated, that would lead to the fuse blow-out in the vehicle setting block.

2. Do not clean the spiral of the lighter moving part with metal objects, it may cause damage to it.

3. When replacing you should use only those types of cigarette

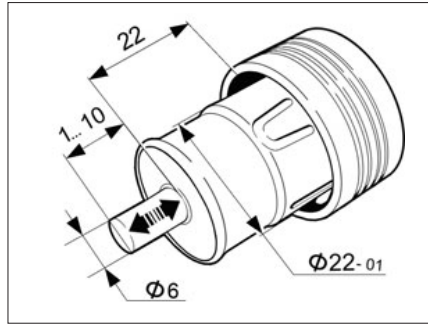

**Fig. 21c. Electrical device plug
in the cigarette lighter socket**

lighters that are recommended for this vehicle, and only of those manufacturers who have the JSC «AVTOVAZ» conclusion.

4. The socket for additional electrical equipment connection (or the cigarette lighter socket, depending on complete units) can be also used to connect only 12-volt electrical appliances with power output maximum 120 W. The socket overloading can cause short circuit. Do not use more than one electrical device. If the electrical device plug (connector) is placed too loose or tightly in the cigarette lighter

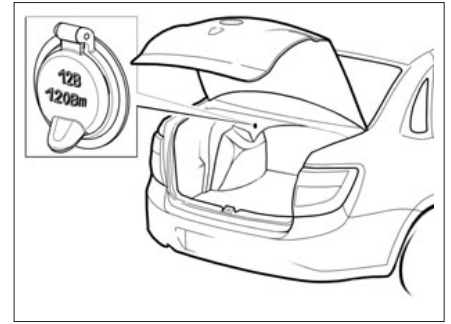

**Fig. 21d. Socket for additional
electrical equipment in luggage
compartment (for some vehicles)**

socket, it can lead to poor contact, or to the plug (connector) hang-up. Use the electrical devices only with appropriate plugs (connectors) shown in Figure 21c.

5. Do not leave the electrical appliances connected to the socket if the driver and passengers leave the vehicle or the vehicle is parked (stored).

Warning

Do not touch the cigarette lighter heating spiral, it can cause burns or damages to the heating spiral.

BONNET

To access the to the engine compartment pull handle  (Fig. 22), located on the left side of the instrument panel under illuminating engineering control module (see Fig. 28), raise the bonnet and through created air space **push the protective hook tab to the right** (Fig. 23). Raise the bonnet and set the stop 1 (Fig. 24) into special bonnet catch bracket, as shown in the Figure. Thereat, for easy fixation it is not recommended to open the bonnet in excess (for more than 10 centimeters) from the top end of the set stop 1.

Free closing of the bonnet should be made from maximum 25 centimeters height between the edge of the bonnet and the top cross member of the front end carrier. When closing the bonnet, check the lock for reliable operation: when closing, a distinctive click should be heard.

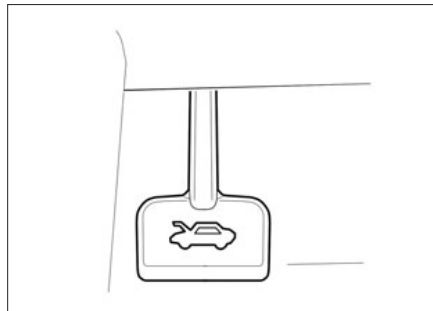

Fig. 22. Bonnet handle

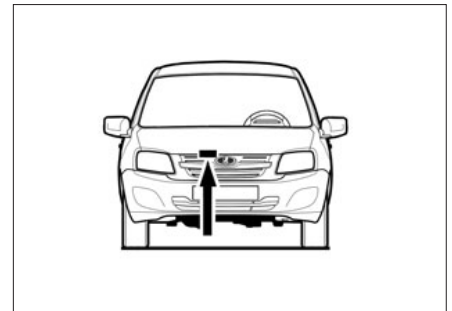

Fig. 23. Protective hook tab

Warning

The bonnet is a source of increased injury hazard. Therefore, when closing the bonnet, be extremely careful, especially when the children are nearby.

ATTENTION!

To prevent damage, do not turn on the windshield wiper with the bonnet opened.

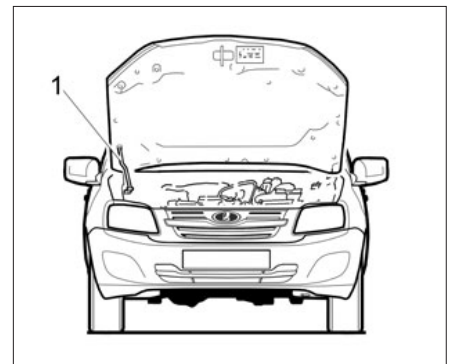



Fig. 24. Opening the bonnet

TRUNK LID

The trunk lid/tailgate is unlocked by turning the key in the lock cylinder (Fig. 25a) counterclockwise (it is locked in a clockwise direction). Luggage compartment in «liftback» vehicle is separated by folding rack 3 (Fig. 25b).

In the design variant the trunk lid/tailgate is opened by pressing the button  in the remote control console or from the passenger compartment with the switch located on the left side of the instrument panel (Fig. 26a) under illumination control unit. For correct operation of «button-lock» system in «standard» and «norm» versions you shall press the trunk lid/tailgate button for not less than 1-2 seconds. **In the design variant** the trunk lid/tailgate is opened by once or double pressing the button.

With the trunk lid/ tailgate opened and external lights switched on the luggage compartment is lighted with the lamp.

In the design variant, the inside handle (Fig. 26b) shown by arrow is provided for closing the trunk lid. To

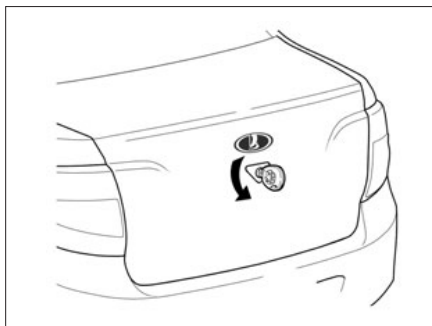

Fig. 25a. Opening the luggage compartment

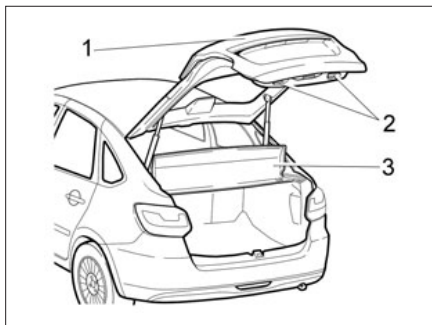

Fig. 25b. Tailgate opening

close the trunk lid from position **A**, take the inside handle and pull the trunk lid down to position **B**. Then lower the inside handle and go on

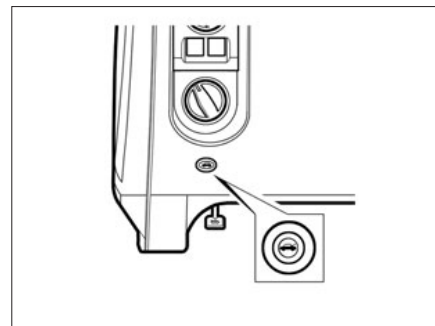

Fig. 26a. Trunk lid latch actuator switch (in the design variant)

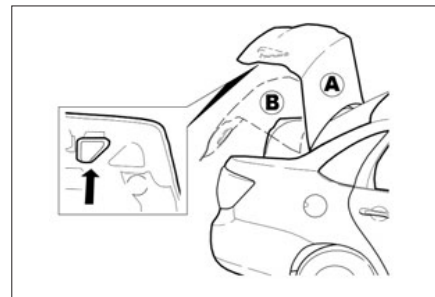

Fig. 26b. Trunk lid inside handle (in the design variant)

with closing the trunk lid by pressing against its external (horizontal) part.

Warning

The trunk lid/tailgate is a source of increased risk of injury. Therefore, when closing the bonnet, be extremely careful, especially when children are near it.

To avoid getting injured during the trunk lid closing in position B, you should release the inside handle and remove your hand out of the trunk lid mechanical trajectory.

ATTENTION!

Do not use the key as a handle for opening and closing the trunk lid, it can cause damage to the key.

FUEL TANK PLUG

To access the fuel tank plug 1 (Fig. 27) open cover 3 located on the vehicle right side. The plug is opened by turning it counter-clockwise. The plug should be screwed up clockwise until the distinctive clicks are heard.

Warning

When opening the fuel tank plug, the blow-out of fuel drops is possible, open slowly!

Flexible string 2 eliminates the possibility of losing the plug when refueling the vehicle and does not allow to close the cap, if the plug is screwed up into the tank filler.

Warning

Petrol and its vapours are poisonous and flammable! Observe safety precautions and fire safety regulations! Avoid skin and cloth contact with petrol. Do not inhale petrol vapours passages. When

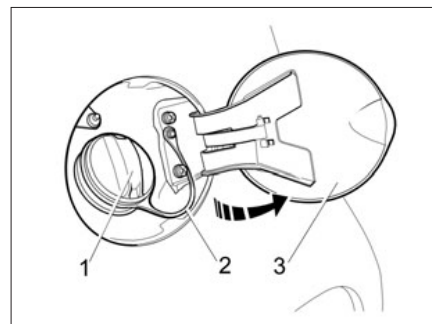

Fig. 27. Fuel tank plug

refueling avoid paint coating and industrial rubber articles contact with petrol.

Do not refuel the vehicle after the fuelling valve has automatically switched off or after the petrol emerged in the fuel tank filler when refueling with the valve not equipped with the shut-down system. Failure to comply with this instruction may result in pouring out the surplus petrol from the fuel tank when the vehicle is parked.

II. CONTROLS AND INSTRUMENTS

INSTRUMENT PANEL

The instrument panel is shown in Figure 28.

1 – **illumination engineering control module** (see Section «Illumination Engineering Control Module and Headlight Adjuster»).

2 – **light alarm switch.**

3 – **driver's air bag module includes an intergrated system with castenets-like horn.**

4 – **instrument cluster** (see Section «Instrument Cluster»).

5 – **wiper switch.**

6 – **ignition starter switch** (see Section «Ignition Starter Switch»).

7 – **light alarm switch.** To turn on the light alarm, press the switch key-button; to turn it off, repress the switch key-button.

When activating the light alarm all turn indicators are in operation. The light alarm warns that at the moment the transport mean poses a danger to other road users. The light alarm operates under all key positions in the ignition starter switch.

8 – **glove box cover.**

9 – **ventilation and heating system control panel in the passenger compartment.**

10 – **system electronic stability control switch (in the design variant).** After the engine start-up the electronic stability control (ESC) function and anti-skidding function are activated automatically. To disable the functions, press and hold down the switch button in the depressed position for 2-3 seconds. At that, the ESC OFF indicator will flash on the **instrument cluster** (see Section «Instrument Cluster»). The enabling of functions is carried out by re-pressing the switch button.

11 – **rear window heating switch.** The rear window heating switch operates only when setting the key in the ignition starter switch to position I. To switch on the heating press the switch key-button, to switch off the heating, repress the switch key-button.

In case, when the heater is actuated, the key in the ignition starter switch is turned to position 0, the heating function is deactivated. When restarting the engine the heating function is restored without pressing the switch key-button.

The check light signal indicator located on the switch key-button will glow orange for the duration of the heater operation.

In the design variant during the rear window heating activation the exterior mirrors heating is also switched on.

In the design variant, the rear window heater and the electric mirror heaters are activated only when the engine is running.

ATTENTION!

1. **To avoid discharging the storage battery, do not switch on the rear window heater for a longer period of time than it is necessary.**

2. **When cleaning the rear window inner surface do not use sharp objects, as well as cleaning agents containing abrasives, for they can damage the conductors applied to the glass.**

12 – **windshield electrical heating switch (in the design variant)** (see Section «Passengers' Compartment Ventilation and Heating Systems»).

13 – **conditioner switch (in the design variant)** (see Section

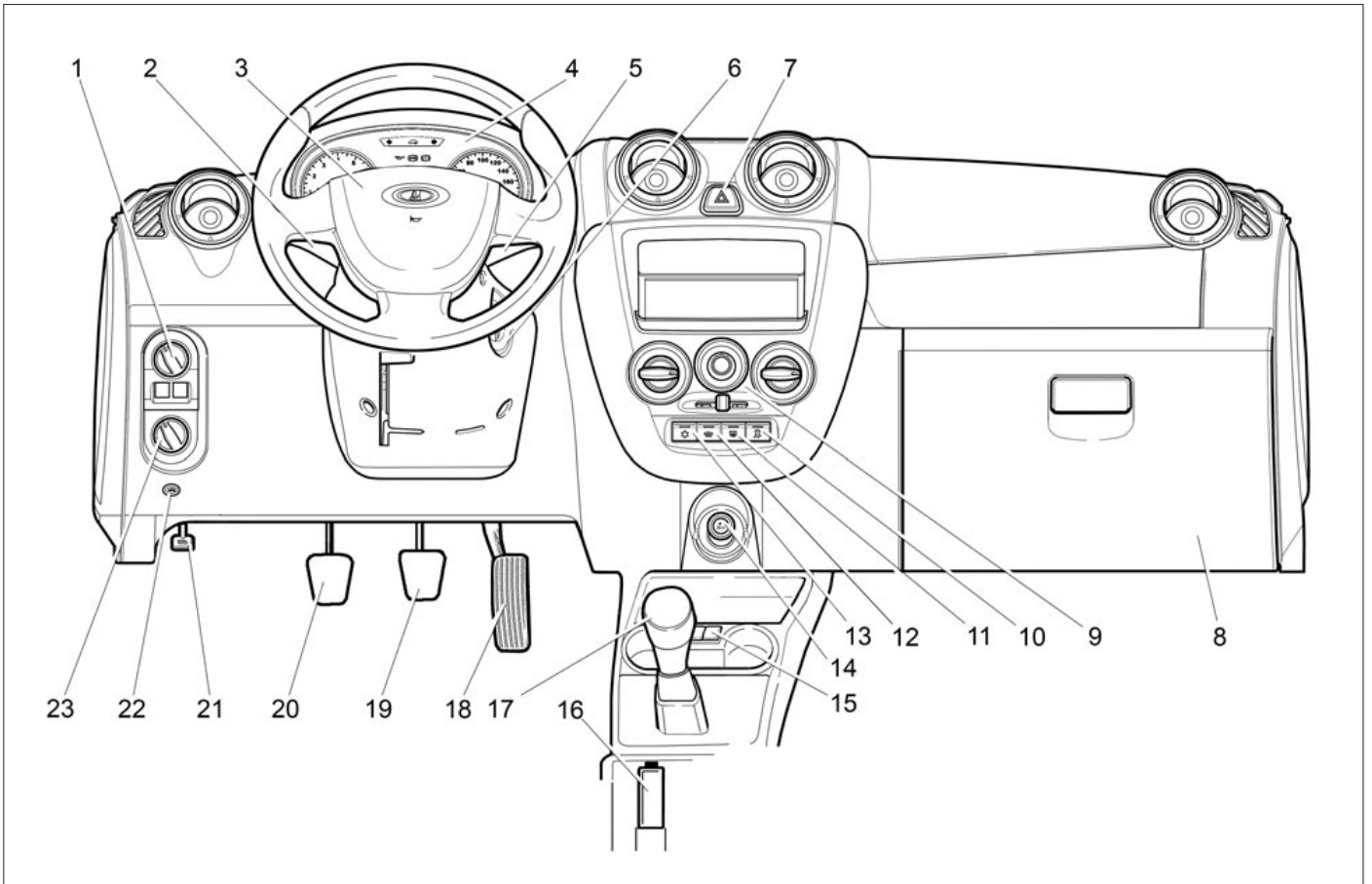

Fig. 28. Controls and instruments

«Passengers' Compartment Ventilation and Heating Systems»).

14 – **cigarette lighter.**

15 – **front seat heating switches (in the design variant)** (see Section «Seats»).

16 – **parking brake lever.** The rear brake pads are actuated when moving the lever up. To return the lever to initial position press the button on the handle end, holding it down, and release the lever.

ATTENTION!

To avoid the brake pads sticking and freezing onto the drums (especially in spring and in autumn), do not park the vehicle with the parking brake switched on for a long time.

Warning

If, in extraordinary circumstances, you have to use the parking brake while driving, do not tighten it too much and constantly hold down the button pressed on the lever. Otherwise, the rear wheels may be locked and the vehicle may be skidded.

17 – **gear change lever.** In the design variant, *in addition to me-*

chanical transmission, the automatic transmission is installed on the vehicle. For additional information about the gear change lever control see Section «gear change Lever».

18 – **accelerator pedal.**

19 – **brake pedal.**

20 – **clutch pedal.**

21 – **bonnet lock actuator lever.**

22 – **trunk lid latch actuator switch (in the design variant).** To unlock the lock press the switch button. After hand withdrawal the button returns to its initial position.

23 – **dipped beam adjuster.**

INSTRUMENT CLUSTER

The instrument panel is shown in Figure 29.

1 – **tachometer.** It indicates the engine shaft rotation speed (x1000 min⁻¹).

The tachometer needle location in the red scale area warns of the increased engine rotation speed. To prevent damage to the engine its maximum speed is limited with electronic engine control system programme. When the rotation speed exceeds approximately 6200 min⁻¹, the fuel supply will be limited. Possible engine conks and traffic blows in this case, are not considered as a failure. After reducing the rotation speed the fuel supply will be resumed.

Do not either allow the engine to run with the rotation speed below 800 min⁻¹ when starting and driving.

ATTENTION!

The engine operation in the hazardous mode is not allowed.

2 – **«Engine» signal indicator.** When switching the ignition on it flashes orange and after the engine starting it goes out.

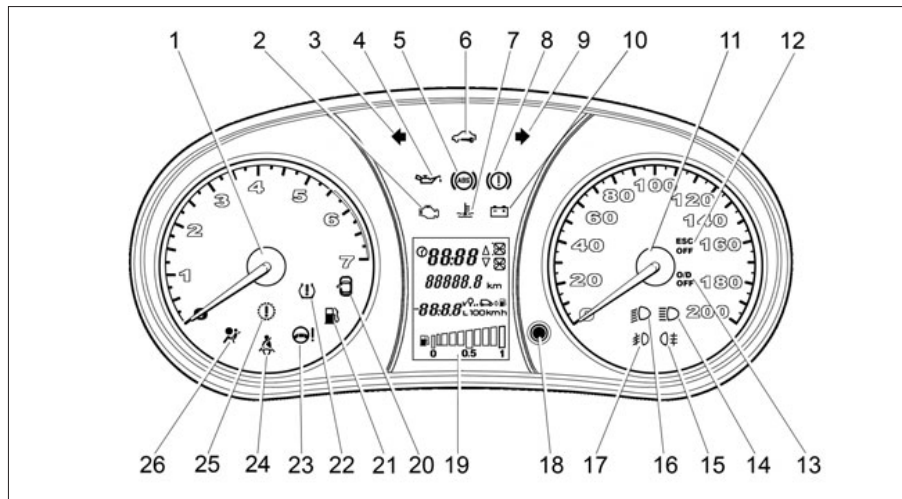

Fig. 29. Instrument cluster

With the engine running the signal indicator burning does not mean that the engine should be stopped immediately – the controller uses the back-up modes that allow the engine to operate under near-normal conditions.

ATTENTION!

However, the failure cause should be rectified at any certified SSNE as quickly as possible.

3 – left turn light signal indicator. It flashes green blinking light when the left turn indicators are switched on.

4 – oil pressure warning switch. When switching the ignition on it flashes red and after the engine starting it goes out.

With the engine running the flashing signal indicator and the intermittent buzzer beep indicate the lack of pressure in the engine lubrication system.

ATTENTION!

With the engine running, in case of the oil pressure warning switch lamp burning, stop as soon as possible observing the traffic rules, kill the engine and contact any certified SSNE for troubleshooting, because insufficient pressure in the lubrication system will lead to engine failure.

5 – anti-lock brake system signal indicator (in the design variant).

It flashes orange when switching the ignition on and it goes out after completion of ABS self-test mode (about 3 seconds).

ATTENTION!

In all other cases, the signal indicator flashing testifies to a malfunction, the correction of which should be performed only at the certified SSNE.

6 – immobilizer signal indicator. It flashes orange and displays the immobilizer condition and the vehicle protection mode.

7 – coolant temperature signal indicator.

When switching the ignition on it automatically flashes red for 2 seconds to confirm the signal indicator good condition.

In the design variant the automatic check is not provided. Thereupon, proper functionality confirmation is checked through testing as follows: press the daily mileage counter reading reset button (18), without the button release, switch on the ignition, release the button – the signal indicators, LCD display and the instruments should actuate for 25 seconds. No alarm signal indication in the intermittent duty indicates that the circuit check is necessary.

The vehicle operation with faulty signal indicator is unacceptable. When the coolant operating temperature is exceeded (above 115°C) it flashes red consistently.

With the engine running

When the coolant operating temperature is exceeded (above 115°C) it flashes red consistently and the intermittent buzzer beep is actuated for a short time. The temperature light signal indicator in the intermittent duty indicates the coolant temperature sensor circuit failure. **Do not run the engine in overheat condition.**

ATTENTION!

The vehicle operation with overheated engine is not allowed. The vehicle must be delivered to the certified SSNE to troubleshoot the cause of the engine overheating.

8 – **«Brake failure» signal indicator.** It flashes red when switching on the ignition for about 2 seconds and it goes out at the end of ABS self-test mode (**in the design variant**). The signal indicator blinking mode indicates that the parking brake is switched on. Consistently flashing signal indicator indicates the low brake fluid level in the hydraulic brake actuation tank or the failure of ABS Electronic Brake-force Distribution. (in this case, it is switched on together with the ABS signal indicator).

With the engine running, the signal indicator actuation is duplicated with a short intermittent buzzer beep.

Warning

The vehicle operation with constantly flashing signal indicator is not allowed. In this case, you should contact any certified SSNE.

9 – **right turn signal indicator.** It flashes green when the right turn signal indicators are switched on.

10 – **storage battery discharge signal indicator.** It flashes red when switching the ignition on and goes out after the engine starting.

With the engine running, light emission of the signal indicator and intermittent beep of the buzzer mean the abnormal operation of the power supply system and indicate a fault in the storage battery charging system, low tension or the rupture of alternator drive belt, or fault in the alternator.

ATTENTION!

In this case, you should contact any certified SSNE.

11 – **speedometer.** It indicates the vehicle speed (km/h).

12 – **ESC (in the design variant).** The Electronic Stability Program (ESC) signal indicator. It flashes orange when switching on the ignition for about 2 seconds and it goes out at the end of the ABS-ESC system self-test mode. During the vehicle driving it flashes and blinks with a frequency of 2-3 times per second in case of the electronic stability control or anti-skid function actuation. The **ESC OFF** signal indicator flashes orange after the electronic stability control and anti-skid functions disabling and it goes out after these functions enabling.

ATTENTION!

In all other cases, the signal indicator flashing testifies to a malfunction, the correction of which should be performed only at the certified SSNE.

13 – **O/D OFF (in the design variant)**. The inhibit signal indicator against shifting to higher gear in the automatic transmission (see Section «Features of driving with automatic transmission»). It flashes orange.

14 – **main beam indicator**. It flashes blue when switching on the main beam.

15 – **rear fog light indicator**. It flashes orange when switching on the rear fog head-lights.

16 – **dipped beam indicator**. It flashes green when switching on the dipped beam lights.

17 – **front fog head-light indicator (in the design variant)**. It flashes green when switching on the front fog head-lights.

18 – **trip counter switch button, reset button for the daily mileage counter and time correction mode switch button**.

Trip counters are switched over by single short push of the button (for «standard» design the switching is performed on the loop «ODO» – «TRIP A» – «TRIP B»). To reset the

daily mileage counter in the daily mileage display mode you should press and hold down the button for 2 seconds (for «standard» design the reset of «TRIP A» or «TRIP B» current counter is performed).

Clock setting («standard» design)

The clock setting mode change-over is made by pressing and holding down the button on the instrument cluster front panel for 2 seconds during the total mileage display. Single push on the button on the instrument cluster front panel results in the clock reading increment for a unit, the accelerated increment for 4 units per second in the clock reading occurs when holding down the button for more than 1 second. When the button is not pressed for more than 5 seconds, the changeover to the minutes correction mode occurs (change of minute values is similar to correction of hours). No further button pressings results in exiting the correction mode and changing over to the clock display mode.

Clock setting («norm» and «lux» design)

The clock setting mode change-over is made by pressing and holding

down the button on the instrument cluster front panel for 2 seconds during the total mileage display. Time correction is performed with ▲ buttons (minute correction) and ▼ (hour correction) on the understeering switch. To exit correction mode press the button on the front panel of the instrument cluster or press no buttons on the understeering switch for more than 5 seconds.

ATTENTION!

Do not rotate the button!

19 – **liquid crystal display (LCD)** (see Section «LCD display»).

20 – **door warning indicator**. It flashes red if the driver's door or (*in the design variant*) any passenger's door of the vehicle is open.

21 – **fuel reserve alarm**. It flashes orange, if refueling is necessary to avoid the engine conks during operation.

The fuel reserve alarm flashes with two or less highlighted segments on the fuel level indicator. The light signal indicator actuation is accompanied by intermittent buzzer beep (2 repeated switching on/off for 0,5 seconds for each).

Simultaneous flashing of the alarm and «empty» shapes of fuel gauge segments indicates a fault in the fuel level sensor circuit.

22 – **signal indicator for alarm pressure reduction in tyres (in the design variant).**

It lights orange if tire pressure descends.

23 – **electric power steering alarm (in the design variant).** It flashes orange when switching the ignition on and goes out after the engine starting.

ATTENTION!

In all other cases, the signal indicator flashing testifies to a malfunction, the correction of which should be performed only at the certified SSNE.

24 – **safety belt reminder (in the design variant).**

It flashes red when switching the ignition on, if the seat belts are not fastened. When driving the vehicle with the speed of more than 10 km/h, **switching on** of the light indicator is immediately duplicated with an intermittent buzzer beep (switch on/off/on cycles relatively for 0.5/0.25/0.25 second within 90 seconds of until the belts are fastened or the ignition is keyed off); at a speed of up to 10 km/h the beep will sound after 60 seconds of non-stop driving.

Warning

When driving be sure to fasten your seat belt and do not carry unbelted passengers!

25 – **transmission malfunction indicator (in the design variant).**

26 – **air bag indicator (in the design variant).** It flashes orange when switching the ignition on and it goes out after completion of FSR (Fire Safety Regulations) self-test mode (in 3 seconds).

ATTENTION!

In all other cases, the signal indicator flashing testifies to a malfunction, the correction of which should be performed only at the certified SSNE.

The instrument cluster operates in a self-test mode. To activate the self-test mode, press the trip counter switch button, then switch on the ignition, without releasing the button (with no engine starting).

After switching on the ignition the pointers of indicating instruments (tachometer and speedometer) will move from zero to maximum values (4 times), while on the liquid crystal display (LCD) all segments will highlight and all alarm signal indicators will be switched on, controlled with

the instrument cluster micro controller. (**For design variant** of the instrument clusters with no trip computer (only the time and the total/daily mileage is displayed on the LCD)):

– fuel reserve, low brake fluid level/manual brake, BAT discharge, alarm oil pressure, unfastened seat belts, air bag failure, breakdown of engine, engine overheating, immobilizer.

For design variant of the instrument clusters with no trip computer and with no outside temperature display:

– OverDrive indicator, ABS, transmission fault, tire fault, unclosed doors.

For design variant of the instrument clusters with a trip computer and with outside temperature display:

– main beam, dipped beam, ESC, ESC OFF.

If in the self-test mode you press the trip counter switch button, then the LCD will highlight the instrument cluster software number in the LCD top line and the instrument cluster number in the middle line. The self-test mode will stop in 25 seconds after it starts, or when the signal of speed or revolutions of the engine shaft appears.

LCD display readings for «standard» equipment

LCD display readings mode	LCD readings	
	minimum	maximum
Mileage, <i>km</i>		
Daily run, <i>km</i>		
Current time, <i>hours: minute</i>		
Fuel level		

LIQUID CRYSTAL DISPLAY

Digital display:

- the top line displays current time or (*in the design variant*) the gear change prompting display mode, as well as the automatic transmission display mode;
- the middle line displays at option the total mileage or the daily run;
- the bottom line (*in the design variant*) displays the outside temperature or the trip computer functions.

LCD display readings for «norm» equipment

LCD display readings mode	LCD readings	
	minimum	maximum
Mileage, <i>km</i>		
Daily run, <i>km</i>		
Current time, <i>hours: minutes</i>		
Car-system voltage, <i>V</i>		
Current fuel consumption, <i>l/100km</i>		
Average fuel consumption, <i>l/100 km</i>		
Residual driving distance, <i>km</i>		
Automatic transmission operation		
Fuel level		
Gearshift prompter		

LCD readings for «lux» equipment

LCD display readings mode	LCD readings	
	minimum	maximum
Mileage, <i>km</i>	000000 km	99999.9 km
Daily run, <i>km</i>	00000.0 km	9999.9 km
Average speed, <i>km/h</i>	000 km/h	1200 km/h
Current time, <i>hours: minutes</i>	00:00	23:59
Travelling time, <i>hours: minutes</i>	00:00	99:59
Gear change prompt	▼	▲
Car-system voltage, V	00.00 V	120.0 V
Current fuel consumption, <i>l/100km</i>	00.0 l/100km	99.0 l/100km
Average fuel consumption, <i>l/100 km</i>	00.0 l/100km	99.0 l/100km
Fuel consumed, <i>l</i>	00.0 l	999.9 l
Gear change prompt tone switch on/off	0500	0510
Residual driving distance, <i>km</i>	000 km	999 km

LCD display readings mode	LCD readings	
	minimum	maximum
Automatic transmission operation	PRND 2 0234	
Fuel level		
Outside temperature, °C	-90°C	30°C

Graphic display shows the fuel level. The fuel reserve signal indicator flashing and the sound buzzer beep indicate that, to avoid the engine conking or its stoppage, it should be refueled.



ATTENTION!

Never allow running out of fuel! This can lead to emergency situation on the road because of your vehicle stop unexpected for other road users.

Gearshift prompter function

Gearshift prompter is function that defines necessity to shift to higher or lower gear (to assure the most cost-efficient operation of engine) and informs driver about it. Function is applied to vehicles with manual gearbox (MG) only.

LCD indicator data of «Norm» version

LCD indicator data mode	LCD indicator data	
	minimum	maximum
Gearshift prompter	▼ 	▲ 

On/off sound indication for gearshift prompter

Use BK-reset or OK button (*in optional design*) at combination switch.

Line of LCD instrument panel indicates condition of gearshift prompter (on/off).

Information displayed at LCD:

- «**GSI 0**» – sound notification of gearshift prompter is off;
- «**GSI 1**» – sound notification of gearshift prompter is on.

Indicatio of recommended gearshift

Signal meaning	Recommendation
1–6	Recommendation to put-up the gear «▼»
0	No recommendations, function is on
8–14	Recommendation to put-down the gear «▲»
7	Function is off, no indication

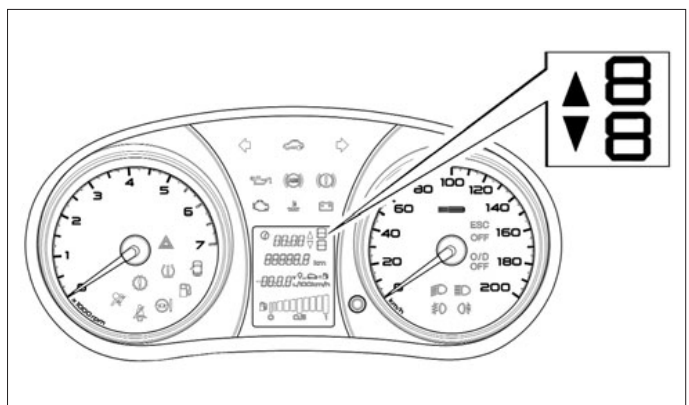

Fig. 30. Gearshift prompter function in instrument panel

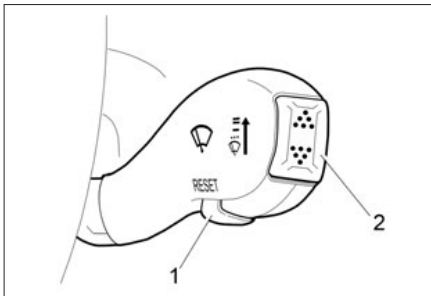

Fig. 31. Trip computer control buttons on the wiper lever (in the design variant)

TRIP COMPUTER CONTROL (in the design variant)

Trip computer control buttons are shown in Figure 31:

Button **1** – reset of trip computer readings, gear change prompt tone switch on/off.

Button **2 (when pressing the key upper arrow)** – switching the selection mode of the trip computer functions «in a loop» forward, setting minutes in the time setting mode.

Button **2 (when pressing the key lower arrow)** – switching the selection mode of the trip computer functions «in a loop» backward, setting hours in the time setting mode.

LIGHTING CONTROL MODULE AND DIPPED BEAM ADJUSTER

Exterior light switch 1 (Fig. 32a) has three fixed positions (or four *in the design variant*):

0 – exterior lights are switched off;

– tail lights are switched on;

– dipped or main beam is switched on depending on the position of the light alarm switch;

– *in the design variant* in this position the tail lights or the dipped beam headlight is switched on/off automatically depending on the exterior lighting. The light sensor is combined with the rain sensor and is located on the windshield behind the rear-view mirror.

The exterior lighting automatic control system (lighting system) allows to switch on and off the tail lights and the dipped beam headlights depending on the level of exterior lighting. For example, in twilight, as well as at the entrance to the tunnel or the garage.

The lighting system operates only when the ignition is on.

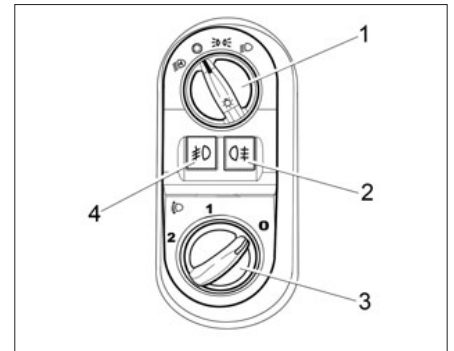

Fig. 32a. Lighting engineering control module and dipped beam adjuster

Warning

The moment of switching on the exterior lighting by automatic control system may not meet the safety requirements. Therefore, use of this system does not relieve the driver of responsibility for observing safety requirements and traffic rules.

Dipped beam adjuster switch.

Before operation of the vehicle with dipped beam headlights switched on, make sure of the correct position of the dipped beam hydraulic adjuster **handle 3** depending on the vehicle load state.

The positions for the dipped beam hydraulic adjuster handle (Fig. 32b) depending on the vehicle load state:

0 – the driver or the driver + the front passenger;

1 – the driver + 4 passengers or the driver + the load in the luggage compartment;

2 – the driver + 4 passengers + the luggage in the luggage compartment.

If necessary, adjust dipped beam by turning the **handle 3** to align the handle mark with one of the marks on the scale corresponding to the vehicle load state.

When setting the electrical adjuster handle to position outside of scale marks, asynchronous passing of dipped beam of the left and right headlight units is possible, which is not a defect.

Warning

Correct adjustment of the beam tilt angle reduces the dazzling of oncoming traffic drivers.

To avoid poor lighting of the roadway do not set the handle to end position counter-clockwise.

Rear fog lights switch. To switch on the fog lights, press key-button 2 with the dipped beam on. Re-pressing of the button turns off the fog lights.

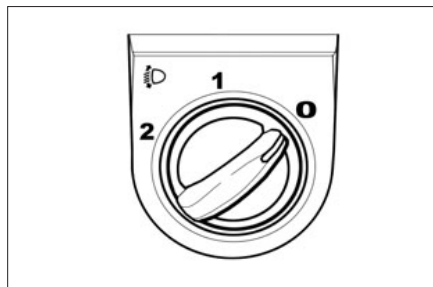

Fig. 32b. Dipped beam headlights adjuster

Front fog lights switch (in the design variant). To switch on the fog lights, press switch button 4 with the tail lights on. Re-pressing of the button turns off the fog lights.

In the design version the vehicle has function «Illuminated track». With ignition is off it is necessary to open the driver's door. Switch the main beam on by holding the light alarm switch lever in non-fixed position, after the lever released the dipped headlights will be switching on for 40 seconds.

With «Illuminated track» function on it is possible to switch it off by re-switching the main beam on holding the light alarm switch lever in non-fixed position or by ignition switching on, in case the operating time is not up.

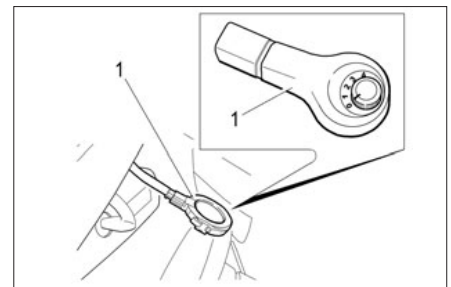

Fig. 33. Rain and light sensor

Warning

When driving in conditions requiring fog lights or fog lamps, with the automatic control system of exterior lighting on (exterior light switch is in position $\equiv \text{A}$ – in the design variant) the exterior light switch must be changed to position $\Rightarrow \text{0} \Leftarrow$ or $\equiv \text{D}$.

RAIN AND LIGHT SENSOR

In the design variant the vehicles are equipped with combined rain and light sensor located on the windshield behind the rear view mirror (Fig. 33).

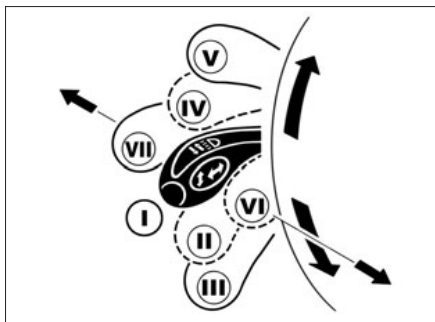

Fig. 34. Light alarm switch lever

LIGHT ALARM SWITCH

I (Fig. 34) – **neutral position**. The dipped beam is on if the headlight beam is switched on with the exterior light switch.

II – **left turn indicators are switched on**. Non-fixed position.

III – **left turn indicators are switched on**. Fixed position.

IV – **right turn indicators are switched on**. Non-fixed position.

V – **right turn indicators are switched on**. Fixed position.

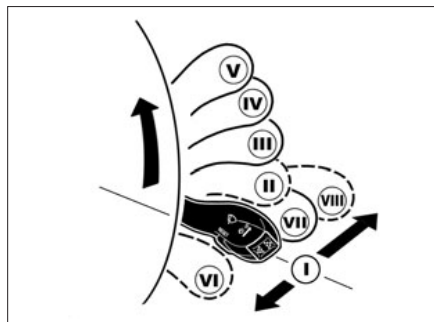

Fig. 35. Wiper lever

VI – pull, **light signaling**. Main beam is switched on, regardless of the exterior light switch position. Non-fixed position.

VII – push, **main beam is on**, if the headlight beam is switched on with the exterior light switch. Fixed position.

WIPER SWITCH

The windshield wipers are turned on by changing the key in the ignition starter switch to position I.

I (Fig. 35) – **neutral position**. Window wipers and washers are switched off.

II – **intermittent operation of the windshield wiper is switched on**. Non-fixed position.

III – **intermittent operation of the windshield wiper is switched on**. Fixed position.

IV – **low speed of the windshield wiper is switched on**. Fixed position.

V – **high speed of the windshield wiper is on**. Fixed position.

VI – pull, **windshield washer is switched on**. Non-fixed position.

VII* – push, **rear window wiper is switched on (in the design variant)**. Fixed position.

VIII* – push, **rear window wiper and washer are switched on (in the design variant)**. Non-fixed position.

In the intermittent operation the wiper strokes its blades once per several seconds at a constant inter-

* For «liftback» and «universal» body vehicles; it is not used in «sedan» body vehicles.

val, regardless of the amount of drops on the windshield.

In the design variant the vehicle is equipped with automatic control system of the windshield wiper (cleaning system) enabling to switch on and off the wiper automatically. It depends on raindrops availability on the windshield.

The cleaning system operates only when the ignition is on.

To enable the cleaning system you should changeover the rain sensor switch 1 (see Fig. 33), located behind the rear-view mirror, from position **0** to any position from **1** to **4****, and switch the wiper lever to position **III** (intermittent operation mode). Thereupon, the wiper blades make one stroke, and then they will be switched on or off depending on the amount of raindrops on the windshield.

If the cleaning system has already been enabled, so when switching on the ignition the wiper blades also make one stroke and the cleaning system is engaged into operation.

When detecting a fault the cleaning system will be automatically switched to «manual» wiper control mode.

To disable the automatic cleaning system and switch to the «manual» wiper control mode you should change the rain sensor switch to position **0** (extreme left position). In this mode the wiper lever assembly manual control to appropriate position is performed.

When switching off the ignition the wiper operation stops. The blades are set to parking position.

If, before the ignition was switched off, the wiper operated in one mode at a constant speed of cleaning, then, after switching off the ignition, the wiper blades may stop in the non-parking position. To switch the wiper blades to the parking position you should changeover the wiper lever to position **I** or **III** no later than in 30 seconds after switching off the ignition.

To remove smudges, deposits of road salt or pavement elements, clean the wiper blades and windows with washer fluid periodically. Availability of fat, wax, insects, etc. on the windshield can lead to irregular operation of wipers and to appearance of smudges on the window. If smudges are not removed after applying the

washer fluid, clean the outside of the window and the wiper blades with a soft cloth using special detergents. After cleaning, wash the window and the wiper blades with water.

ATTENTION!

1. To prevent damage, do not use the windshield wiper with the bonnet opened.

2. You should not switch on the wiper in case the windshield is dry. This may result in scratches on the window or damage the wiper blades. When the window is dry, always use the window washer before switching on the wipers.

3. If the wiper blades froze to the window, before switching on the wiper you should first switch on windshield heating (see Section «Ventilation and Heating Modes»). An attempt to switch on the wipers with its blades frozen to the window can lead to damage of the blade rubber tape.

4. Do not clean the wiper blades with petrol or solvent, it will damage them.

** 4-step adjustment procedure of rain sensor sensitivity is provided. The highest sensitivity is after setting the switch clockwise to the extreme right position **4**.

IGNITION STARTER SWITCH

0 (Fig. 36) – **switched off**. Fixed position. The key is removed.

When the key is removed the mechanism of locking mechanical anti-theft device is activated. For steering shaft to be completely locked, turn the steering wheel to the right or to the left until it clicks.

To turn off the mechanical anti-theft device, insert the key into the ignition switch and slightly turning the steering wheel to the right and to the left, turn the key to position **I**.

I – **ignition**. Fixed position. The key is not removed.

II – **starter** Non-fixed position. Automatic return of the key to position **I**. The key is not removed.

If the engine does not start with the first start attempt, turn the key from position **I** to position **0** and in about 40 seconds attempt to start again.

ATTENTION!

Do not hold the key in position II for more than 10 seconds.

The ignition starter switch includes starter restarting lock-out mechanism that prevents repeated switching of the key

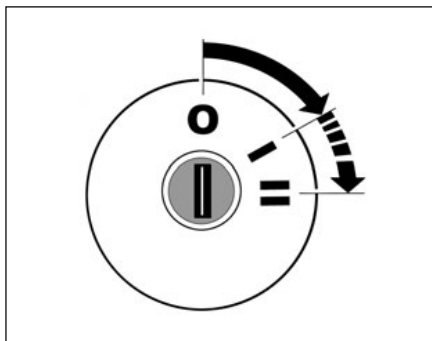

Fig. 36. Ignition starter switch

from position I «Ignition» to position II «Starter».

For repeated switching of the key from position I «Ignition» to position II «Starter», you must first turn the key to position 0 «Off», and then try again.

Warning

It is expressly prohibited to switch off the ignition and remove the key from the switch when driving – this results in abrupt increase of brake pedal pressure force and steering control locking.

If the ignition is off and the key is

left in the ignition switch, then when opening the driver's door the buzzer gives an intermittent beep, warning of leaving the key in the ignition switch.

If the ignition is off and the key is removed from the ignition switch, but the tail lights are left on, then when opening the driver's door, the buzzer gives two intermittent beeps to warn about exterior lighting being switched on.

GEAR CHANGE LEVER IN MECHANICAL TRANSMISSION

The chart for the gear change lever in the mechanical transmission is applied on the top of its handle (Fig. 37a or 37b):

1, 2, 3, 4, 5 – first, second, third, fourth and fifth gears.

R – reverse gear.

Neutral position – between the third and the fourth gear.

Before starting the engine, make sure the gear change lever is in the neutral position.

The vehicle is equipped with reverse gear selection line mechanical interlocking. For backing run, stop the vehicle, press the clutch pedal, after a pause (not less than 3 seconds), «pull down» the gear change lever all the way in, then shift it to the left until it stops, and move it forward in the vehicle travel direction.

If you fail to engage the gear, return the lever to the neutral position, release the clutch pedal, then depress the clutch again and try to get into the gear.

Pay attention to full clutch release when changing the gears over, for

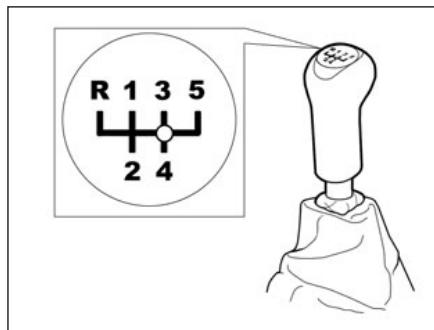

Fig. 37a. Gear change lever in mechanical transmission

that the clutch pedal must be depressed until it stops. **Otherwise, it may cause troubles in gear change and increased wear of synchronizers.**

Change over to forward gears according to the chart without applying excessive force to the gear change lever, as well as no efforts capable to cause the lever «pull down».

In the design variant, the mechanical gear box is equipped with cable-operated actuator, its scheme is shown in Figure 37b. To change over to reverse gear pull the gear change lever from the neutral position to the right until it stops,

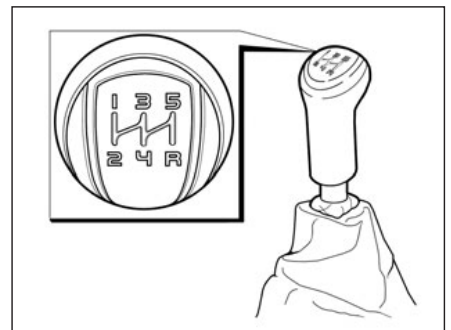

Fig. 37b. Gear change lever in mechanical transmission (in the design variant)

and move it back in the vehicle travel direction.

ATTENTION!

Actuate the reverse gear only after the vehicle full stoppage.

The reverse gear actuation is carried out only with a stationary vehicle and no sooner than in three seconds after depressing the clutch pedal.

While driving, do not keep your arm on the gear knob, this may result in damage and premature wear of gear change parts (apply no force to the gear change lever knob).

GEAR CHANGE LEVER IN AUTOMATIC TRANSMISSION (in the design variant)

Automatic transmission (A/T) mode changeover is carried out by moving the gear change lever in the longitudinal direction (Fig. 37c), depending on the desired direction of travel. For unlocking the lever it is necessary to press release button **1** on the gear change lever knob. To change over the lever from position **N** to position **D** and back, as well as from position **1** to position **2**, and further, to position **D**, you should not press the release button. The selected mode is displayed on LCD display in the instrument cluster. Gear change lever position indication, shown in the decorative moulding next to the lever, is presented as informational and is not used during gear change over.

Accelerator pedal **2** and brake pedal **1** are shown in Figure 37d. When installing the automatic transmission the clutch pedal is not available.

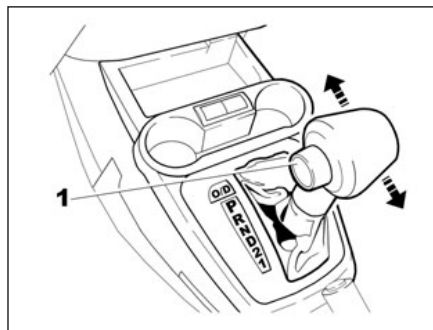

Fig. 37c. Gear change lever in automatic transmission

Lever position:

P (parking) is used to prevent the vehicle rolling when parked or when the engine is started. At that, the parking brake can be switched on or off.

R (back running) – reverse gear. It can be actuated only after the vehicle fully stoppage, with the engine idling.

N (neutral gear) is used for starting the engine in the parking simultaneously with the parking brake on. In addition, this gear change lever position can be used to start the engine after its abrupt stoppage during driv-

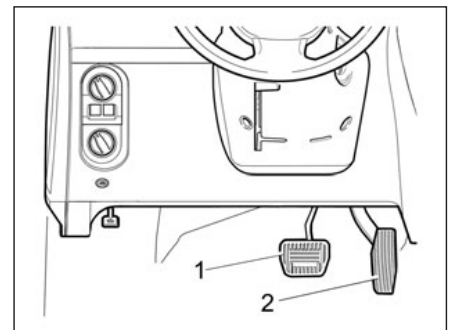

Fig. 37d. Pedals with automatic transmission

ing, but without using the parking brake.

ATTENTION!

In case, when driving, you switched the gear change lever to position **N accidentally, let the engine RPM to slow down before actuating **D** mode (it is activated without pressing the release button and then pick up speed again.**

D (driving) is used for starting and driving in automatic gear change mode. In this mode, to perform overtaking quickly or climb a considerable gradient, press the accelerator

pedal as far as it can go. Thereupon, the gear box will change over to low gear depending on the vehicle current driving speed.

2 (second gear) is used when climbing a gradient and for effective engine braking.

1 (low gear) is used when climbing steep gradients at low speed, as well as when driving in severe road conditions (sand, deep dirt, etc.). In addition, this gear ensures the most effective engine braking on steep descents.

O/D – «Overdrive» button. It is used for economy driving mode.

For more information on driving with automatic transmission, see «Features of driving with automatic transmission».

Automated transmission (AMT) instruction manual (in the design version)

AMT transmission is based on the 2180 five-speed gear box, gear shift control is performed by synchronous operation of two electromechanical actuators, that controlled by TCU transmission controller.

Shifting actuator is installed instead of the standard cable gearshift.

Vehicle with AMT transmission has no clutch pedal; all clutch operation processes are automated, supported by electrical signals and performed by clutch actuator.



All transmission modes are indicated by letter symbols on the decorative selector cover and digitally duplicated on the instrument cluster display:

• Operation mode

indication: **N R A M**.

• Engaged gear indication of operation mode: **1 2 3 4 5**.

• Indication of all modes, except **R**, is displayed simultaneously with the engaged gear number, eg:

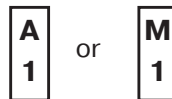

The pedal unit of a vehicle with AMT transmission is controlled only by right foot.

Besides the reverse gear indicated by **R** the transmission has got two main driving modes:

– automatic mode **A**, when gear shifting is performed automatically

depending on the travel speed, engine speed and other parameters without driver's involvement.

– manual mode **M**, when gear shifting is performed by driver by the light touching of selector contacts in positions:

- + – upshifting,
- – downshifting.

Selector control is easy, with the fixed positions of modes, except the touches for upshifting and downshifting in **M** mode (+ и –).

Engine start up is possible only in **N** neutral position and when the brake pedal is pressed. This is a safety requirement and the engine will not get started in any other position of selector.

At turning the ignition key the engine start up delay for **2–3** seconds is possible, it caused by initialization procedure of transmission control system.

Movement is possible after the switch of the selector into **A** or **M** position when the brake pedal is pressed. At the accelerator pedal pressing the clutch gets engaged and the vehicle starts moving. If the accelerator pedal is not pressed, the vehicle doesn't get started, but it can move free, in spite of the activated

driving mode and engaged gear. AMT transmission crawl mode is not envisaged by design.

If after the engine start up selector is moved to **M** position, gear 1 will get engaged. Then you can shift the gears in manual mode. Speed-increasing gears in **M** mode in the regular operation conditions are switched only by driver sequentially 1-2-3-4-5 and in reverse order.

Be careful, at the starting and driving at the first gear you can reach the maximum engine speed, it is designed specially to drive onto the steep and long ascents by using only the first gear. If the maximum engine speed is reached at the second and at the other gears, the system will switch to the speed increasing gear to prevent the engine failure. The downshifting at the speed decrease is performed automatically depending on the speed reduction. **M** mode allows to brake a vehicle by combination of the pedal brake and engine by means of sequential gear downshifting.

You can feel delays at all driving modes caused by the operation of gearbox synchronizing system during shifting process. **A** mode is set up for the maximum comfortable

driving style, and delays are a bit longer than at the **M** mode.

A and **M** modes have brick acceleration function called kick-down, it is actuated depending on the strength of pressing the accelerator pedal down, at the **M** mode it is slower.

You can move selector lever from **A** position to **M** position and back while driving. If you need to switch to the self shifting mode, or you need preliminarily to shift down during driving at the mode **A** (eg. overtaking with driving in the oncoming lane), you can switch to **M** mode, perform maneuver and then switch back to the mode **A**, and the system will engage the gear appropriate to the speed.

If you switch the lever from **A** position to **R** position while driving, the system will block the reverse gear engagement. At the same time the **R** mode indicator will blink, indicating the driver that this switch is impossible.

In order to exclude transmission failures the system will allow no engagement of gear inappropriate to the speed in all cases.

If swaying of vehicle is required, for example at skidding, you can switch **R – A** modes and vice versa through **N**, but without stopping at **N** and with-

out brake pedal pressing, provided the speed is not over **3 km/h**.

If speed is over **3 km/h** the switching from **A** to **R** and from **R** to **A** is possible only when brake is pressed. In some cases for the successful engagement of the reverse gear it is required to wait 8 sec in order the system could perform the reverse gear engagement function successfully.

You can turn off the ignition at any selector position. But in **N** position the vehicle can move and you can tow it, in the other positions of selector the vehicle will stay in the selected mode (**R** – at reverse gear, **A** and **M** – at the first gear) and the clutch is locked. In any case, depending on the slope it is necessary to prevent spontaneous vehicle swaying by the hand brake.

By driving onto the steep ascents (such as parking lots, ramps) at the low speed, it should be taken into account that when the engine speed is lower than the minimum one (650 min^{-1}), the clutch is disengaged automatically to prevent the engine stoppage. At the slope it can lead to the moving of the vehicle downwards. In this case you need to drive at the engine speed higher than the minimum one.

When the battery is dead you can start the engine up from wheels by towing. To do this you need to accelerate the vehicle at **N** neutral to the speed above **7 km/h**, only then to switch the selector to the **A** position. Transmission controller will register speed and activate the start-up from wheels function.

The «**gear**» indicator displaying on the instrument cluster indicates the transmission malfunction. In this case the AMT system diagnostics by specialized diagnostic device is required. The shifting at that could be uncomfortable, very slow or abrupt.

When the clutch is overheated the «**gear**» indicator is blinking and in addition the clutch pulsates during the start-up to warn the driver. In this case at the restart of engine the warning lamp will blink off after the cooling-down of clutch. If it didn't happen it is necessary to check the AMT system by specialized diagnostic equipment.

VENTILATION AND HEATING SYSTEM CONTROL IN THE PASSENGER COMPARTMENT

In the design variant, the vehicle can be equipped either with ventilation and heating system or with climate control system.

1 – **electric fan operation mode switch handle.**

2 – **heater operating temperature switch handle.**

3 – **recirculation shutter control lever knob.**

4 – **air flow distributor control handle.**

Heating and ventilation system is designed to create interior comfort temperature, with the value regulated by the ventilation and heating system control unit (Fig. 38). However, it should not provide the interior air temperature lower than that of the ambient air.

In the design variant, in the air box of the heating and ventilation system there is an air filter designed for cleaning the air from dust, pollen, smoke, and bugs entering the passenger compartment. Replacing the filter and cleaning the drain hole in the front panel are carried

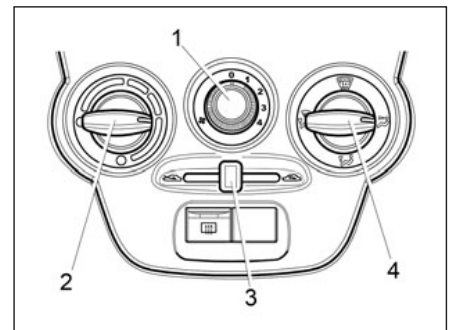

Fig. 38. Ventilation and heating system control unit



out at any certified SSNE every 15,000 km (for driving along the dusty roads – if necessary).

Warning

Proper use of the heating and ventilation system controls in accordance with recommendations below will enhance the traffic safety due to fast cleaning of windows from snow and ice, as well as defogging.

Remember – quick cleaning of windows and the most efficient interior heating are possible only

when the engine is fully warmed up!

Recirculation shutter control lever handle 3 is intended for increase of fresh air supply into the passenger compartment, meanwhile, it is put in the extreme left position , and when **handle 3** is in the extreme right position,  the external air supply into the passenger compartment is locked (recirculation mode). This mode can be used in summer when driving through a tunnel or when driving in the «traffic jam» to avoid the supply of air saturated with exhaust gases to the passenger compartment.

Warning

Recirculation mode can be enabled only for a short time, for at that the fresh air is not supplied to the passenger compartment, and the windows may weep.

To increase the air supply to the passenger compartment, move the electric heater fan switch **handle 1** to one of four positions. Position **1** – minimum speed of air supply in the passenger compartment, positions **2** and **3** – average speeds, and posi-

tion **4** – maximum speed. When the switch is in position **0** the fan does not operate; fresh air is not supplied to the passenger compartment.

ATTENTION!

When driving the vehicle, it is recommended to switch the heater fan to the first speed, as minimum, to create excessive pressure in the passenger compartment (to avoid ingress of dust and dirt through the body leaks), as well as to prevent the windows from weeping.

Control unit handle 4 is used for air flow distribution.

If **handle 4** is set with its white mark in front of symbol  the air is supplied to the lower part of the passenger compartment, to the driver and passengers' feet areas.

If **handle 4** is set with its mark in front of symbol , the air is supplied to the lower part of the passenger compartment, to the driver and passengers' feet areas, as well as through the windshield demister nozzles and the front door window demister nozzles.

If **handle 4** is set with its mark in front of symbol , the air is supplied through the windshield demister nozzles and the front door window demister nozzles.

If **handle 4** is set with its mark in front of symbol , the air is supplied through the side and central nozzles to the upper part of the passenger compartment for blowing the driver and passengers.

The air flow rate is adjusted by direct action on 1, 2, 3 and 4 nozzle deflectors (Fig. 39) through changing the deflector positions right down to their full closing. To open the desired nozzle press the special hole in the deflector. The air flow direction is adjusted by the deflector rotation.

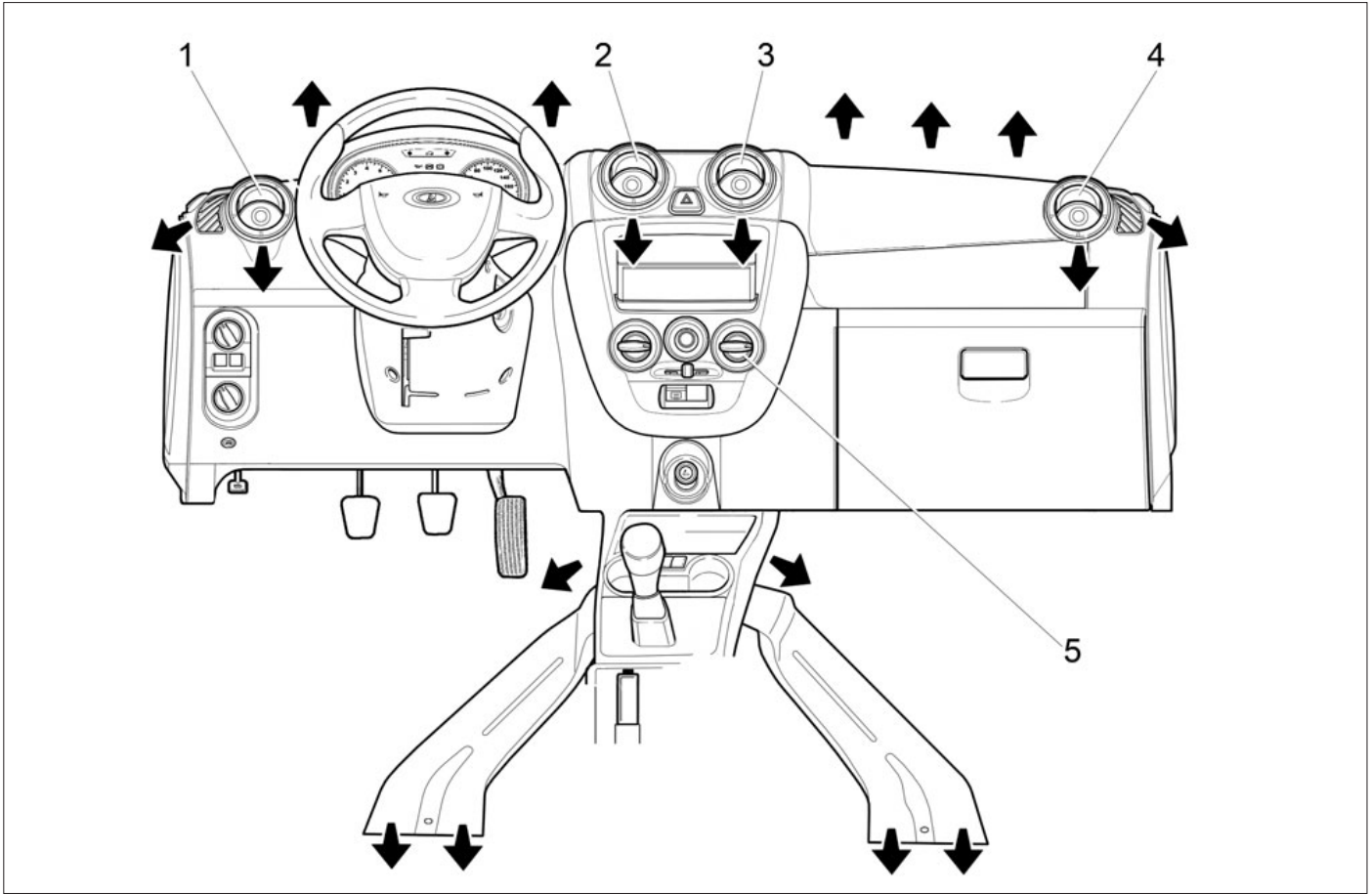



Fig. 39. The directions of the air flows out of deflectors and ducts

VENTILATION AND HEATING MODES

Passenger compartment ventilation

For passenger compartment ventilation (supply of unheated air) it is necessary to set the handles of ventilation and heating system control unit 5 to the following positions:

- **handle 2** (see Fig. 38) should be turned clockwise to the extreme right position up to stop (blue mark point on the control unit), and **in the design variant handle 2** (see Fig. 40) counter-clockwise to the extreme left position up to stop (blue mark point);

- **handle 4** should be set with its mark opposite symbol  ;

- **nozzles 1, 2, 3 and 4** (see Fig. 39) should be opened by pressing the dedicated hole in the deflector;

- **handle 1** (see Fig. 38) of the electric heater fan operation mode switch should be switched to the desired flow rate of air supply to the passenger compartment;

- in case of windshield misting set **handle 4** to position .

Window misting prevention

Under high air moisture, for example, during the periods of heavy rains, the vehicle windows may mist. To prevent misting of the windshield and the front door windows, do the following:

- **handle 2** (see Fig. 38) should be turned counter-clockwise to the extreme left position until it stops (red mark point on the control unit), and **in the design variant handle 2** (see Fig. 40) it should be turned clockwise to the extreme right position up to stop (red mark point);

- **handle 4** should be set to position .

- **handle 1** of the electric heater fan operation mode switch change over to position **2, 3 or 4**.

Warning

Under high air moisture it is inadvisable to use recirculation mode (handle 3 is switched to extreme right position ) , for, in this case, the windows may mist.

ATTENTION!

Do not switch on the fan during washing (switch position 0).

Cleaning the windows of snow and ice

For windshield and front door windows fast cleaning of snow and ice it is recommended to set the ventilation and heating system control unit handles to the following positions:

- **handle 2** (see Fig. 38) should be turned counter-clockwise to the extreme left position until it stops (red mark point on the control unit), and **in the design variant handle 2** (see Fig. 40) should be turned clockwise to the extreme right position until it stops (red mark point);

- **handle 4** should be set to position .

- **handle 1** of the electric heater fan operation mode switch set to maximum speed of the air supply to the passenger compartment.

Speed-up passenger compartment heating

For speed-up heating of passenger compartment it is recommended to set the ventilation and heating system control unit to the following positions:

– **handle 2** (see Fig. 38) should be turned counter-clockwise to the extreme left position up to stop (red mark point on the control unit), and **in the design variant handle 2** (see Fig. 40) – clockwise to the extreme right position up to stop (red mark point);

– **handle 4** should be set to position ;

– **handle 1** of the electric heater fan operation mode switch set to maximum speed of the air supply to the passenger compartment;

– open the side and central nozzles.

Providing comfort temperature in the passenger compartment

Once the windows have been cleaned, and the passenger compartment temperature has reached the desired level, it is recommended to do the following:

– by rotating **handle 2** set the desired temperature;

– **handle 4** should be set to position ;

– by rotating **electric heater fan switch handle 1** select the desired

rate of hot air supply to the passenger compartment.

ATTENTION!

To ensure good operation of the heating and ventilation system, regularly clean the openings for fresh air intake of snow, ice and leaves, located in front of the windshield.

Prevent the increase of the air moisture in the passenger compartment against evaporation of water and snow from carpets and rubber mats and clean them in time. Keep the vehicle windows clean, for the dirty windows accumulate more air moisture, and they thaw longer.

Do not contaminate the vents for exhaust air in the luggage compartment side trimming.

When the heating system operates at full capacity, it is not recommended to open the windows.

Trouble-free operation of heating and ventilation system control is provided with strict adherence to the above sequence of its handles switching.

Climate system control features

Climate system control makes it possible to provide heating as well as ventilation of the air supplied to the vehicle passenger compartment. Upon that, the air temperature and moisture reduction in relation to the outside air is reached in the passenger compartment, and also dust and other volatile solids are removed.

1 – **electric fan operation mode switch handle.**

2 – **heater temperature mode switch handle.**

3 – **recirculation shutter control lever handle.**

4 – **air flow distributor control handle.**

5 – **conditioner switch key.**

6 – **windshield electrical heating switch key (in the design variant).**

When the air conditioner works defogging is carried out more effectively, especially when outside air moisture is high.

To activate the cooling function (air conditioning function) with the windows closed:

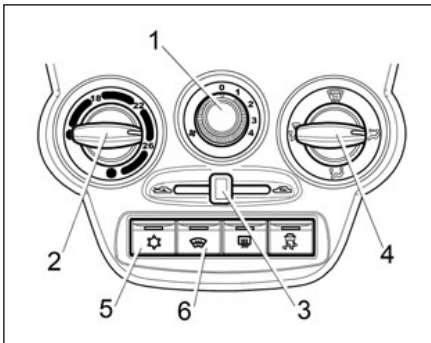



Fig. 40. Climate system control unit (in the design variant)

1. Switch on the ignition (start up the engine).
 2. Switch on the electric fan by setting **handle 1** (Fig. 40) to one of positions 1, 2, 3 or 4.
 3. Set **handle 4** with your mark opposite symbol .
 4. Press the conditioner switch key 5 with symbol . The check light indicator located on the switch key will flash green for the duration of the air conditioner operation.
- During conditioner operation drops emergence is possible in the engine compartment. This is normal,

for the vehicle air conditioning system removes moisture condensed on the evaporator from the passenger compartment.

To disable the cooling (conditioning) function re-press the conditioner switch key.

ATTENTION!

Air conditioner operates only when the engine is running, when the outdoor temperature is not below 5°C and when handle 1 is set to any of these positions 1,2, 3 and 4 (i. e. with the electric fan on).

In the handle 4  position, at least one of the nozzles 1, 2, 3 or 4 (see Fig. 39) should be open, otherwise the air cooling heat exchanger (evaporator) can get iced and block the air flow supply to the passenger compartment.

To set the desired air temperature in the passenger compartment turn **handle 2** (see Fig. 40) clockwise – for raising, counter-clockwise – for lowering the temperature. The temperature will be automatically maintained within the climate system control performance and the specified tolerance.

For speed up of cooling the air in the passenger compartment it is recommended to switch on the recirculation mode for a short time, for this, change **handle 3** to the extreme right position , at that, the outside air supply stops and the air intake out of the passenger compartment starts.

ATTENTION!

It is not recommended to use the recirculation mode durably, because that leads to microclimate deterioration in the passenger compartment due to air exchange termination of the interior and exterior air and ejection of excessive moisture out of the compartment. It causes the driver to drowse, and the windows can mist.

Cost-effective operation of the climate system control

The conditioner compressor actuation is performed from the vehicle engine, thus, its operation in the air cooling mode effects the fuel consumption. To possibly reduce the air conditioner usage time, you should

observe the following recommendations:

- before a drive, at high air temperature in the passenger compartment, it is necessary to air it by opening the windows or doors for a while;
- to improve air cooling efficiency when switching on the cooling function, always close the windows and hatches;
- if comfort interior air temperature can be achieved without switching on the refrigeration unit, it is preferable to use the ventilation mode.

Maximum cooling

It is used for the most intensive air cooling in the passenger compartment in hot weather or when the vehicle was stored in the sun for a long time:

1. Air the passenger compartment, for this, slightly open the windows and doors for a short time.
2. Switch on the air conditioner by pressing **the conditioner switch key 5** with symbol . The check light indicator on the switch key will

highlight green for the duration of the air conditioner operation.

3. Switch on the recirculation mode, for this, **handle 3** should be switched to extreme right position



ATTENTION!

It is not recommended to use the recirculation mode durably, for this leads to the microclimate deterioration in the passenger compartment by reason of the air exchange termination with the outside air and because of excessive moisture ejection out of the compartment. It causes the driver to drowse, and the windows can mist.

4. Turn **handle 2** counter-clockwise to the left position up to stop (blue mark point on the control unit).

5. Set **handle 4** with its mark opposite symbol .

6. Set **handle 1** of the electric heater fan operation mode switch to maximum rate of the air supply to the passenger compartment.

When the desired temperature level is achieved in the passenger compartment, by rotating **handles 2 and 1**, you can select the optimum

comfort mode in the passenger compartment.

In the cooling mode it is not recommended:

- to set the interior air temperature with a difference from outside air temperature of more than 10-12°C, especially for short trips in the urban cycle;
- to direct the cooled air flows to the side of the head, open skin areas, since it can lead to hypothermia and subsequent disease;
- to direct cooled air flow to the windshield, which, due to great temperature differential, can cause windows misting.

ATTENTION!

Turning on the air conditioning system when driving with a trailer in highlands or under heavy traffic conditions can cause the engine overheating.

Follow the coolant temperature alarm. If it indicates the engine overheating, turn off the air conditioner. Otherwise, a damage or total failure of the engine is possible.

Since the system compressor is actuated from the vehicle

engine, during the air conditioner start-up, small changes in the engine operation are possible.

Technical maintenance

To ensure the air conditioning system efficient operation, it is necessary to enable it for a short time at least once a month irrespective of the weather or season of the year. Refrigeration machine is charged with a coolant and is under high pressure. Self supporting troubleshooting in the system operation is not allowed. Consult an official dealer or a certified SSNE.

Windshield electric heating (WSEH)

In the design variant the vehicle is equipped with WSEH system, which is used for quick removal of frost and moisture from the windshield.

To activate the system, press switch key 6, when actuating the indicator flashes on the switch key. The system operates only when the engine is running.

WSEH system is switched off:

- automatically after 6 minutes;
- when re-pressing the switch key during heating operation;
- when car-system voltage falls below the acceptable level;
- when the engine speed drops below the acceptable level;
- when switching off the ignition.

In case the system failure to start-up or automatic cut-off before the time specified, it is recommended to switch off some other consumers and try again.

The WSEH system is most effective when used together with the interior heating and ventilation system set to the mode of cleaning windows of snow, ice or the mode of defogging (see the relevant Manual Sections).

RADIO RECEIVER AND MEDIA PLAYER

In the design variant the vehicle is equipped with the radio receiver and the media player. Figure 41a demonstrates the external appearance, and the additional information about the radio receiver and the media player is represented in Appendix 4.

- 1 – Touchscreen display.
- 2 – Microphone.
- 3 – Memory card slot **SD**.
- 4 – **MUTE** – off sound button.
- 5 – Volume adjustment knob with on/off button.
- 6 – **MODE** – select mode button.

Where to connect the USB-drive

Multi-Media System (MMS) has an option to connect the USB-drive of 1 to 64 GB to play back audio, video and images.

Plug 1 (Fig. 41c) for connecting USB-drive is located in the upper left corner of the side glove box.

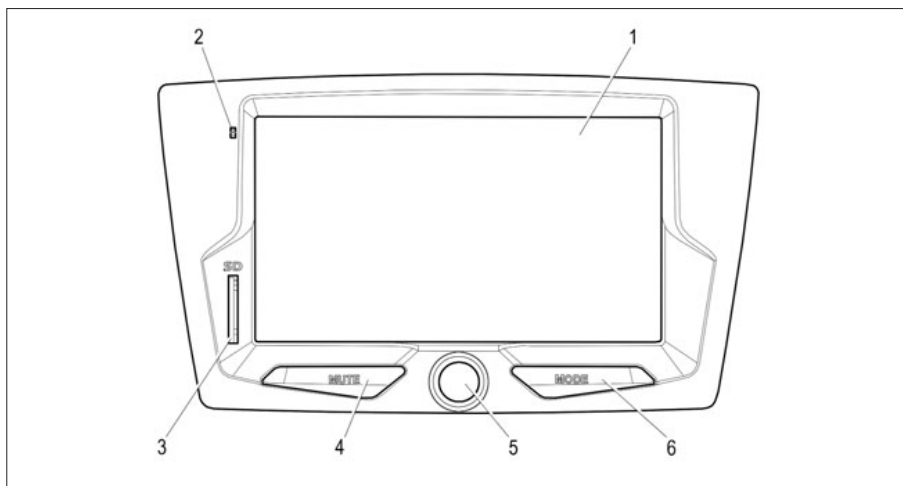

Fig. 41a. Radio receiver and media player



Fig. 41b. Radio receiver front panel appearance and form (in the design version)

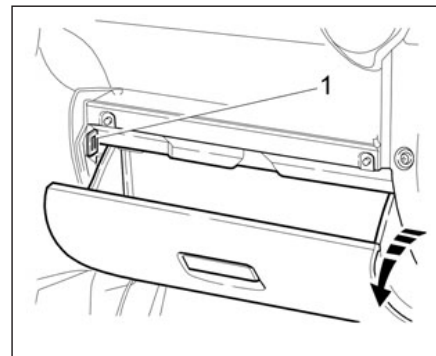

Fig. 41c. USB connector location

VEHICLE OPERATION

NUMBER PLATE INSTALLATION

Front and rear number plates 4 (Fig. 42a) are secured with two self-tapping screws 2 and washers 3. Front number plate in the «liftback» car is secured analogically; before installing the rear number plate 5 (Fig. 42b) insert plastic bushings 2 into holes of back wall 1, set number plate 5 and secure it with self-tapping screws 3 and washers 4.

SAFETY VEHICLE OPERATION BASICS

Your safety and environmental protection depend on technical serviceability of your vehicle and compliance with the rules of its operation. The following recommendations will greatly enhance your safety on the roads and will keep your vehicle in good condition.

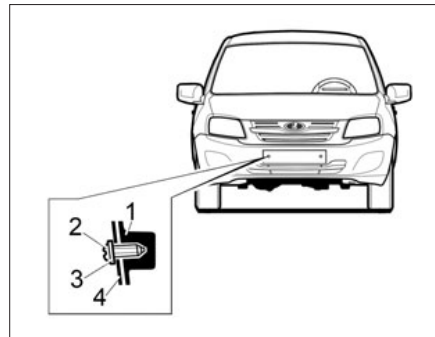

Fig. 42a. Fastening of number plates

Safety precautions during vehicle operation

Do not exceed the vehicle load specified in this Manual. Overloading causes to suspension components, premature tire wear and loss of the vehicle stability.

Prevent fast driving on roads with broken covering, for sharp blows can deform the body and suspension components.

Regularly check the condition of protective rubber covers of the steering rack, ball bearings, shift rod, front wheel drive joints, as well as of the steering joints protective

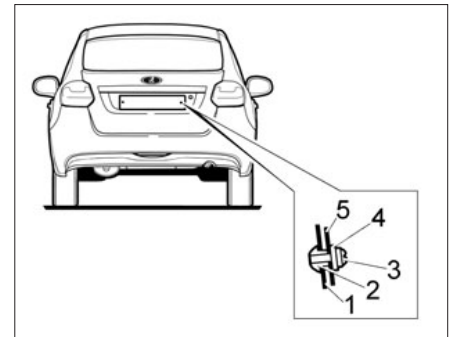

Fig. 42b. Mounting rear number plates in «liftback» vehicle

caps. If a cover or a cap is damaged, improperly installed or twisted, the joint or the mechanism will be penetrated with dust, water and dirt, that would cause their increased wear and breakdown. Therefore, replace any damaged cover or cap with the new one, and fix the improperly installed or twisted component.

In order to reduce the level of vibrations transmitted from the front suspension to the steering gear, the steering gear housing is attached to the body panel by means of rubber mounts. The inherent structural elasticity of connection provides mobility of the crankcase towards the body.

ATTENTION!

For lubrication of components and assemblies use the materials recommended by the manufacturer in Appendix 1. The use of other materials may result in premature wear and damage to these components and assemblies.

To avoid the engine operation with excessively high revolutions during the vehicle driving, change the gears in time. Thus, you will reduce the engine wear and fuel consumption.

ATTENTION!

The vehicle engine is designed to use the gasoline with octane number not lower than that specified in Appendix 1. Operation of the vehicle using the low octane number gasolines results in its failure!

Remember to check the tyre pressure regularly, for the operation of tyres with the pressure different from the recommended, leads to their premature wear, fuel consumption increase, as well as to the vehicle stability and driveability reduction.

Warning

Pressure differential on one axis for only 0.02–0.03 MPa

increases fuel consumption and deteriorates driveability, and can lead to skidding during emergency braking!

The vehicle is equipped with the clutch cable with the clutch lining wear compensation mechanism, due to which the drive manual adjustment is exclude for the whole service life of linings. To avoid the clutch slipping after gear change and clutch engagement, take your foot off the pedal.

ATTENTION!

While driving, do not keep your foot on the clutch pedal and do not keep your hand on the gear lever, this may result in damage and premature wear of parts of the gear change lever assembly.

During the pedal operation in the clutch engagement and disengagement process, gear components coupling and decoupling occurs in the clutch lining wear compensation mechanism, that can be accompanied with the click-type distinctive sound. This click should not raise fears concerning the clutch linkage performance disturbance; it can appear and disappear as the linings wear, thereupon, the clutch

engagement and disengagement completeness is fully ensured.

The appearance of inconspicuous rattling in the vehicles equipped with the electrically assisted steering (*in design variant*), when reaching the extreme steering wheel positions, is not the criterion of failure.

Keep a continual watch on the cleanliness of terminals and storage battery clamps and check them for reliable connection. Remember that terminals and clamps corrosion of as well as their poor connection cause sparking in the poor contact location, which can lead to the vehicle electronic equipment failure. Generator operability check by removing the storage battery clamps with the engine running is also not allowed.

Warning

The vehicle is equipped with high energy ignition system. Therefore, it is dangerous to touch the ignition system components with the engine running.

In addition, it is not recommended to test the high-voltage circuits «for sparkling», because this may lead to the failure of the ignition system elements. During maintenance of the

vehicle with an 8-valve engine check high-voltage wires for reliable connection to coils and spark plugs.

When dismantling the high-voltage wires from the ignition system devices hold on their protective caps. Do not touch high-voltage wires when dismantling!

To avoid the storage battery discharge when the engine is not running, do not leave the key in the ignition switch for a long time.

Avoid sharp opening of doors at the end of their stroke. To avoid deforming the door front edges, do not leave the doors open when stopping during strong wind.

In winter, when the ice or snow layer on the drop windows makes it difficult to roll them up and down, to prevent damaging the window-lift mechanism do not apply excessive force when rotating the handle. To avoid power windows failure it is necessary to clean the windows of ice and snow.

New vehicle operation

During the new car run not over 2000 km:

- after the first thousand kilometers check the wheel bolt tightening torque and if necessary tighten the

Table 2

New vehicle driving speeds, km/h

Distance run, km	Transmission gear				
	first	second	third	fourth	fifth
0 – 500	20	40	60	80	90
500 – 3000	30	50	70	90	110

bolt till torque 87,7 N•m;

- when driving the car do not exceed the speed limit 110 km/hour and crankshaft speed 3500 min⁻¹;

- when driving the vehicle do not exceed the speeds, specified in Table 2;

- in accordance with road conditions, timely put into higher transmission gears, avoiding engine overloading;

- do not tow a trailer or other vehicle;

- driving modes – sudden starting from rest, including starting with the handbrake on, turning while skidding front wheels at maximum engine speed – is not allowed, for this causes damage to the differential.

Before the end of the brake pads breaking-in period (during the 3000 km run) relative difference of the rear

axle wheels braking forces, when measuring according to GOST R 51709-2001 technique, should not exceed 35%.

Warning

New brake pads should break-in (burnish), that's why during the vehicle running-in period or after the brake pads replacement, the vehicle should be operated with increased caution, because at this period the braking system is not maximum efficient.

Preparing the vehicle for driving

ATTENTION!

Before driving out of the garage or the parking space, check the vehicle for technical condition.

For this purpose:

1. Check and adjust air pressure in the tires (see Table 3).
2. Check the oil level in the crankcase, and, if necessary, adjust it.
3. Check the levels of coolant, brake and washer fluids and, if necessary, adjust them.
4. Check the bulbs of the exterior lights for their normal operation and cleanliness.
5. Check the wiping system operation.
6. Check the mirrors, the seats and the seat belts for their proper installation.
7. Check the service brake system (no failure of the brake pedal) and the parking brake system (handbrake lever lock) for normal operation.

Traces of oils and fluids under the vehicle mean that its components and assemblies are not sealed. In this case, you must contact any certified SSNE for troubleshooting and the reasons for their appearance removal.

ATTENTION!

Without putting it off, repair detected failures at the certified SSNEs.

Driving position behind the wheel

Warning

Safe driving technique largely depends on the driver's correct position. Correct driving position – the driver rests on the seat back tightly enough, his/her legs are not fully spread for full pedal travel, and both arms, slightly bent at elbows, hold the upper part of the steering wheel. The body position should be firm but not strained – it prevents fast exhaustion.

Engine start

These recommendations provide starting of properly operating engine with storage battery, charged by at least 75%, with engine oil of SAE viscosity grade, corresponding to environmental temperature (see Appox. with gasoline of volatility class for winter period, depending on climatic area of application.

1. Before starting the engine, insert the key into the ignition switch, press the brake pedal, depress the clutch pedal until it stops, shift the

gear change lever to the neutral position.

2. Switch on the ignition, make a pause for a few seconds so that the electric petrol pump has time to increase the pressure in the fuel rail up to operating value.

ATTENTION!

During starting the engine, do not press the accelerator pedal. Cold start of the engine is optimized to the ambient temperature minus 27 °C and the driver taking no control of the throttle valve plate. When pressing the accelerator pedal (until it stops) in the engine start mode, the fuel supply is locked for the drain engine cylinders of excess fuel after unsuccessful starts.

3. Switch on the starter. Hold down the fully depressed clutch pedal until the engine starting stops, and the engine idle running. After starting the engine, release the ignition key – the starter will be switched off.

Note. It is not recommended to switch on the starter for more than 10 seconds.

When the allowable time for switching the starter is exceeded, EECs (electronic engine control system) opens the starter circuit.

4. If within 10 seconds of the starter operation the engine is not started, repeat the start no earlier than in 40 seconds.

5. If the second start attempt was unsuccessful, the third attempt should be made no sooner than in 40 seconds with the accelerator pedal fully depressed (cylinder blowing mode). In 6-8 seconds after the cylinder blowing release the accelerator pedal smoothly.

Note. After unsuccessful starts, if it is necessary to press the accelerator pedal, you can use the hand brake lever instead of the brake pedal.

6. If the third start attempt is a failure, the reason is related with the ambient temperature below minus 27 degrees C (the limit of cold start possibility without the auxiliary units), or the engine is faulty, or there is some deviation from the recommendations specified above.

ATTENTION!

To start driving by using the starter is not allowed. Under nor-

mal conditions, start driving in the first transmission gear.

Warning

Exhaust gases are toxic! Therefore, the room where you start and warm up the engine, should be well ventilated.

Vehicle with the fuel injection system. Operation features

The «Engine» alarm light indicator flashing, when the engine is running, signals about fault availability. But it does not mean that the engine must be stopped immediately – the controller operates its back-up modes, that allow the engine to operate under close to normal conditions.

ATTENTION!

However, the cause of the fault should be rectified at any certified SSNE as quickly as possible.

The engine with the fuel injection system, equipped with the catalytic converter and the oxygen sensor, operates properly, if only natural gasoline is used. In the short term of time the leaded gasoline make these elements a failure, the smoky

exhaust appears, the fuel consumption increases rapidly and the vehicle dynamics deteriorates.

ATTENTION!

The catalytic converter is an expensive unit providing environmental protection. The catalytic converter can be damaged with misfires in the engine cylinders (external manifestations – the engine conks and jerks when driving the vehicle), for the unburned fuel in the cylinders will be ignited in the catalytic converter and the temperature will rise sharply, that will cause damage to the catalytic converter element. Electronic engine control units have the function of protecting the converters against misfiring. When misfires appear in one or two cylinders the «Engine» alarm indicator is switched in the flashing mode; the fuel delivery is switched off in the cylinders, where the misfires were detected; then the «Engine» alarm flashes continuously until you stop driving. When misfires occur, it is necessary to take urgent measures to eliminate them.

Vehicles equipped with the catalytic converters can be started by towing only with the cold engine. It is more preferable to start the engine by means of other storage battery or external power supply of 12 volts; at no account use the starter to drive the vehicle.

The vehicle is equipped with the downpipe with the catalytic converter, having high operating temperature, that's why it is strictly prohibited to place and store flammable materials and objects (cloth, paper, etc.) in the engine compartment to prevent possible fire hazard.

Vehicle with the electric power steering. Operation features

In the design variant the vehicle is equipped with the electric power steering (hereinafter – EAS) due to which driving becomes easy and pleasant. The EAS is located in the steering column. The EAS quickly tracks all control impact actions on the steering and increases the torque transmitted by you through the steering wheel, according to the

specific algorithm depending on the vehicle speed.

ATTENTION!

Low-intensive force on the steering wheel provided with the EAS allows turning the steering wheel at high speed. Thereupon, in the extreme positions, minor impacts of the steering limiter with the crankcase, accompanied by a slight knock are possible. To avoid damage to the steering box you should control the rotation speed of the steering wheel in extreme positions and apply no force when the rack rests against the limiter.

It is not recommended to drive with a faulty EAS when the control indicator lights up in the instrument cluster.

The EAS failure cause must be located and removed as soon as possible at the vehicle manufacturer service and sales network enterprise.

The EAS does not work or can be switched off in the following situations:

– with no running vehicle engine;

– with the vehicle speed sensor disconnected;

– when the vehicle is parked for a long time (more than 5 minutes) with the engine running at the speed of 1500 min⁻¹;

– during the car-system voltage reduction;

– at the vehicle engine low idle speed.

Such switch-offs are caused by the EAS operation algorithm and are not considered as malfunction.

VEHICLE DRIVING

It is allowed to start driving the vehicle only after cleaning the windows of ice, snow and misting up to the safety traffic level.

It is recommended to begin driving the vehicle under negative ambient temperature no earlier than in 30 seconds after starting the engine. To provide partial warming of oil in the gearbox it is required that for some time the engine runs at the minimum idling speed with the clutch pedal released. If you do not have such possibility, and you warm up the engine and the gearbox while driving, after a long parking at a low ambient temperature, it is recommended to drive in lower gears at low speed of the engine shaft for some time. Progressively as the oil in the gearbox warms up, change consistently to higher gears.

ATTENTION!

To avoid damaging the gear-shift mechanism inside the gearbox due to frozen oil, do not apply force to the gear lever and do not perform shocking (sharp) throws into gears.

The front drive vehicle driving technique is specific and slightly different from the driving technique of the rear drive vehicle, especially while cornering. When approaching the turn you should assess it in advance, and depending on the the turn radius and the road conditions, reduce the speed and drive through the turn in the «tension» mode, gradually increasing the rotation speed of the engine crankshaft. This allows you to pass the turn sustainably even in the slippery areas, avoid sudden braking or rapid throttle pedal release in the turn, which can lead to the loss of wheel gripping, respectively, to the loss of the vehicle control.

If possible drive without sharp accelerations and decelerations, as it leads to increased tire wear and increased fuel consumption. Fuel consumption is also increased because of low air tire pressure, worn or dirt spark plugs, when using motor oils for the engine with the viscosity higher than recommended.

ATTENTION!

Sudden starting from rest, including starting with the hand-brake on, turning with skidding

front wheels at maximum engine speed are not allowed!

Fuel consumption is also increased when towing a trailer. In addition, when towing the trailer the loads on the body, the engine and the transmission are increased, and reduce their operation life.

While driving, keep an eye on the operation of various systems on the relevant devices and alarms. Under normal conditions the red alarm indicators should not flash – their actuation signal that it is necessary to check the relevant system at any SSNE. When driving on puddles reduce the speed to avoid hydroplaning, which can cause skid or loss of control. The worn tires increase such hazard.

ATTENTION!

To prevent engine damage caused by water entering its cylinders through the air intake, it is not allowed to overcome body of water with a depth of more than 300 mm. Driving on relatively deep bodies of water should be carried out with the least possible speed in order to avoid formation

of the wave capable of filling in the engine air intake.

After overcoming puddles, and after washing the vehicle or during long driving on wet roads when water enters the brake system, brake smoothly several times to dry discs, drums and brake pads.

Warning

Take particular care and caution during first minutes after starting, because the wetted dust on the road coating slippery surface that drops the wheel grip with the road.

ATTENTION!

After overcoming fords or deep puddles and on intention to park the vehicle for a long time, it is necessary to provide a short vehicle run to dry the assemblies in order to avoid corrosion damage to the clutch collar bearing and front and rear wheel bearings.

While overtaking in rainy weather switch the windshield wiper to the maximum mode (see Section «Wiper Switch») – this will help you to avoid the loss of visibility due to potential

release of water by the wheels of overtaken transport. It is recommended to observe such safety precautions also in case if you are overtaken.

Do not overtake in rain, if the water cloud made with the front vehicle wheels blocks the overtaking zone completely.

When it rains, in order not to drive in the line of water from front vehicles, increase the distance and reduce the speed.

When driving along the side walks during the rain or after it, reduce the speed while driving through puddles to avoid splashing foot-passengers with water.

Driving in winter

To create comfortable environment inside the vehicle at ambient temperature of below zero you should warm up the engine.

During the drive by frosts, before each first switching on of wipers you should check that the wiper blades are not frozen on the windshield. If the wiper blades froze to the windshield, use the functions of the venti-

lation and heating system control unit (see Section «Ventilation and heating system control in the passenger compartment») until the wiper blades are completely thawed.

When driving in snow, if the wiper cannot cope with removal of snow from the windshield and the layer of ice starts to grow on it, use the functions of the ventilation and heating system control unit (see Section «Ventilation and heating system control in the passenger compartment»). Once the windshield warms up and the layer of ice thaws out, remove it using the wiper blades.

Snow adhering to the windshield wiper arms makes it difficult for them to operate properly. Stop off observing the road rules, turn off the wipers and remove the snow.

Warning

Be very careful on wet or slippery road sections – do not brake hard, do not press and release the accelerator pedal hard. For this purpose drive the vehicle smoothly, without the steering wheel sudden motions of the steering wheel. Slow down gradually changing to lower gear in

the transmission by partial braking with the help of foot brake. If, for all that, the vehicle started to skid, steer in the direction of a sideslip and align the vehicle by operating the steering wheel and the throttle pedal smoothly.

Due to wheel slides when starting from rest, the icing often occur in the crossroad locations. Therefore, when approaching such places, speed down in advance on the dry road section.

Driving in mountains

ATTENTION!

When upgrading, timely change to lower gear in the transmission, avoiding overloading the engine and jerking the vehicle.

On long descents use the engine in the braking mode (the accelerator pedal is released with the gear switched on), with partial application of foot brake pedal.

Warning

Do not allow descending with the clutch switched off and using

foot brakes only. That results in brakes heating and brake fluid boiling. Keep in mind that while increasing altitude the brake fluid boiling temperature decreases. The brake fluid boiling in the wheel cylinders means complete failure of the foot brake – the brake pedal fails.

When driving in the mountains keep to the right side of the road. Reduced width of the road and complicated route profile require more care and caution. When stopping uphill or downhill, turn the steering wheel until hard stop so that in case of the vehicle uncontrolled motion start, its wheels bear against the road curb.

When on slippery road do not start mounting to the sharp climb until the vehicle in front has reached its peak.

BRAKING AND PARKING

Warning

Learn how to brake smoothly, avoiding blocking the wheels.

Much more better to brake smoothly with the foot brake and simultaneous change to lower gear in the transmission.

Such technique ensures directional stability of the vehicle even in slippery road sections and, moreover, contributes to fuel economy, increases service life of the tires and brake linings.

If having properly operating suspensions, the front wheels adjusted installation angles of the and normal air pressure in the tires, the vehicle is drawn aside during braking and you have to turn in the steering wheel to keep the direction of driving, it is necessary to check the foot brakes at any certified SSNE.

When sitting down behind the vehicle wheel for the first time, check the brakes at moderate speeds to acquire first skill of braking.

ATTENTION!

To prevent the brake pads sticking to the drums, do not park

the vehicle with the parking brake on for a long time.

Warning

In case one of the braking system circuits is a failure, the second circuit ensures the vehicle braking. Thereupon, the pedal travel extends and the braking efficiency decreases, which, at first moment, you may assess as complete braking failure. In this case do not release the pedal and do not work it repeatedly, as these actions just increase the braking distance, but, on the contrary, step on the pedal to get maximum possible braking effect.

While stopping or parking uphill or downhill apply the parking brake and the first or the reverse gear in the transmission, accordingly.

In order that the brake pads do not to freeze to the drums after driving on wet roads and at low temperatures, do not leave the vehicle in an open area with the parking brake on without drying the brakes by smooth braking operations when approaching the parking lot.

When parking the vehicle during a snowfall it is recommended to depress the wiper arms from the windshield to prevent the blades freezing.

Warning

Do not switch off the ignition when the vehicle is in motion! The engine shut-down sharply increases the force that must be applied to the brake pedal to brake the vehicle.

Anti-lock braking system

In the design variant the vehicles are equipped with anti-lock braking system (ABS) which prevents locking of wheels during braking, thereby ensuring the specified path of movement maintenance and the ability to correct it, as well as minimum braking distance under smooth and hard surface conditions by turning the steering wheel during braking. However, when braking on the road with rough or loose surface (gravel, sand, unrolled snow), the extension of the braking distance, as compared with braking under the same conditions with locked wheels, can take place.

ABS also performs an additional function of electronic brake force distribution, which, in all normal modes of braking and even in case of failure of the the ABS main function, provides optimum ratio of braking force to the front and rear wheels.

ATTENTION!

To prevent the ABS efficiency limitation, do not install the different size tires on the vehicle.

In case of emergency braking, as quickly as possible and with maximum force, press the brake pedal and hold it down until the vehicle stops. While braking hold down the brake pedal when the direction of driving changes.

Warning

Pump braking (releasing and re-pressing the brake pedal) on ABS vehicles increases the braking distance.

Braking with the ABS starts at a speed of more than 8 km/h and it is accompanied by a slight brake pedal pulsation and distinctive hum of the ABS actuators. The ABS stops operating when the vehicle speed is reduced to 3 km/h.

Warning

The ABS alarm flashing, except for self-test mode when the ignition is switched on, means the ABS function failure. In this case, the hydraulic brake drive operation of is not broken. The ABS alarm and the «Brake failure» alarm simultaneous flashing, except for the self-test mode when switching on the ignition, mean the failure of all ABS functions and electronic brake force distribution. In this case, premature locking of the rear wheels and dangerous skidding of the vehicle are possible while braking. In both cases, the trouble should be eliminated at any certified SSNE as quickly as possible.

Electronic Stability Control System

In the design variant, the vehicles are equipped with electronic stability control (ESC system), which in all road conditions during the vehicle deviation from the path of travel set by the driver (drift or skid), brakes one or more wheels automatically and, if necessary, reduces the engine torque, thus offsetting devia-

tion and maintaining the vehicle stability and driveability.

The ESC system also fulfils the ABS, the electronic brake force distribution and the anti-skid functions which optimize the wheels slipping when starting from rest and picking up due to braking the wheels and, if necessary, the engine torque reduction.

Warning

The ESC system actuation accompanied by flashing the ESC alarm indicator, show that the limit of tire gripping has been reached. To avoid losing control of the vehicle you have to adapt your driving style for the real road conditions.

Function HHC (in the design variant)

ESP system (optional) is equipped with function to prevent the car from rolling down when starting movement forward and reverse uphill (HHC – hill hold control).

When stopping uphill with a slope more than 4% hold brake pedal with sufficient force for ensuring the car immobility. When brake pedal relea-

sed and accelerator pedal depressed the HHC function keeps the pressure in brake hydraulic drive till the start moment, but for no more than 2 seconds that prevent cars from rolling down.

HHC triggering is accompanied by specific noise of actuators.

HHC doesn't work when using the parking brake or ESC malfunction.

Auxiliary braking system

The vehicles with the ABS or the ESC systems are equipped with the vacuum booster and an auxiliary braking system, which, according to the rate of pressing the brake pedal, recognizes the need for emergency braking, and automatically provides maximum braking performance as long as the brake pedal is depressed.

VEHICLE TOWING

To tow the vehicle attach the towing rope only to front or rear towing eyes (Fig. 43).

Before towing, insert the key into the ignition switch to position **I**. Observe the traffic rules when towing.

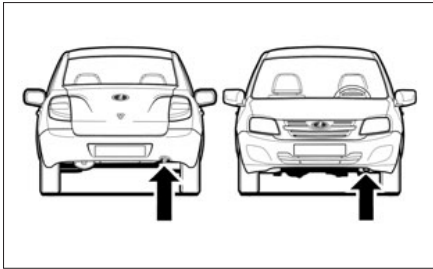

Fig. 43. Towing eyes

When towing, make sure that the towing rope is constantly pulled tight. The vehicle towing must be carried out smoothly, without jerks and sharp turns.

ATTENTION!

The vacuum booster performs its function only when the engine is running. Therefore, when towing the vehicle with the engine off you should press the brake pedal much stronger when braking.

Power steering does not work with the engine off (disabled), thus, the steering wheel forces will increase significantly.

DEFENSIVE PARKING SYSTEM

In the design variant the vehicles are equipped with the parktronic defensive parking system (from the English «parktronic»). The system will help avoiding some deplorable minor accidents material costs following them. **The parking sensors** (Fig. 44) will help you to detect hazardous obstacles, invisible from inside the vehicle.

The vehicle system detects the obstacle in the rear by means of ultrasonic sensors operating on the echolocation principle. The system is designed for warn the driver of approaching to the obstacle when reversing. Warning the driver of approaching the obstacle and reporting about the distance to the obstacle are made by the audible warning device.

With the ignition and reverse gear on, the system comes into operation automatically, at that, a short high tone beep signal sounds. In case the obstacle is located within the detection zone, the system informs the driver of an obstacle by intermittent or continuous beep, depending on

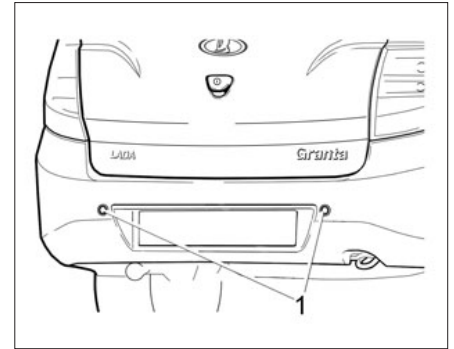

Fig. 44. Parking sensors

the distance, thereupon, the vehicle can move in reverse or stand still.

When approaching the obstacle, starting from a distance of about 100 cm, the system gives an intermittent high alarm, the frequency of which increases when nearing to the obstacle and which gets intermittent at a distance between the bumper and the obstacle of about 40 cm.

Important Note:

It should be borne in mind that complete stop of the vehicle will take some time, depending on the driver reaction, weather conditions, road conditions, braking system operation

features, vehicle inertia, therefore, during the parking system actuation the driver is obliged to minimize the speed and stop the vehicle after intermittent alarm sound signal.

ATTENTION!

Parking system is an auxiliary system that helps the driver estimate the distance to the detected obstacle.

Backing run is considered to be a higher risk manoeuvre. In accordance with «Road rules» requirements the driver must ensure this manoeuvre safety before starting it and during driving. To do this be sure to monitor the situation behind the vehicle by the side mirrors and the rear view mirror.

The parking system includes:

- control unit with diagnostic function that is installed into the luggage compartment;
- two ultrasonic sensors installed in the rear bumper;
- audio signaling device, installed in the area of the back window shelf.

Parking system operation and maintenance features:

1. After actuating the system a

short high tone beep sounds, then the control unit carries out a complex check in order to detect faulty sensors or other system malfunctions.

If a faulty sensor or other system failure is detected, after the switch signal a continuous low chime arises for 3 seconds and then:

- if the left sensor is faulty (in direction of travel), the system signals of a faulty sensor with one low chime;
- if the left sensor is faulty (in direction of travel), the system signals of a faulty sensor with two low chimes;
- if the control unit is faulty, the system gives a low chime for about 2 seconds.

After the alarm signal about a fault the system is switched off.

2. Note that due to ultrasonic waves' propagation features, the system does not detect dangerous obstacles which diffuse or absorb ultrasonic waves. They involve very low, thin, pointed objects, down-filled clothes, soft snow, etc.

It is advisable to use other means of control over the situation behind the vehicle when approaching to

obstacles such as «ramp» due to geometric features of these obstacles.

3. When operating the vehicle with a trailer, to disconnect the parking system you need to connect black-and-blue wire with the vehicle «case», its terminal is near the left rear lamp.

Note. The trailer hitch fitted to the vehicle must have a removable towing bracket, as the system determines the distance from the bumper to the obstacle.

4. To prevent their malfunction the sensors must be kept clean of snow, ice and mud. When cleaning the sensors do not use hard or sharp objects. The sensors must be protected against impacts.

5. Replacement of the of system faulty components is carried out at service and sales network enterprise (SSNE).

AUTOMATIC TRANSMISSION DRIVING SYSTEM FEATURES

Due to installation of four-speed automatic transmission on your vehicle you can choose comfortable, fully automatic transmission mode; or, in extreme driving conditions, change to the lower (**2-nd** or **1-st**) gear.

The left foot is not used when driving, save for exceptional cases of starting off on sharp uphill and downhill that are mentioned below.

Engine start

With the right hand thumb press lock button **1** (see Fig. 37c) and shift the gear change lever to position **P** or **N**. Switch on the ignition and start the engine.

Press the brake pedal and, pressing lock button, shift the gear change lever from position **P** to position **R** or **D** (depending on the desired direction to start driving). Thereupon, your foot should be on the brake pedal, the accelerator pedal must be released.

Warning

If it is necessary to carry out the work on the vehicle with the engine running, set the parking brake and move the gear change lever to position P.

Starting off and driving in the automatic mode

Press the brake pedal and, pressing lock button **1**, shift the gear change lever to position **D**, at the same time you will feel a little push, release the brake pedal and slowly pressing the accelerator pedal, start driving. In most cases, under normal driving conditions, you will not have to use the gear change lever: the gear change will be carried out automatically at the right time and at the optimum speed of the engine shaft, as automation takes into account the vehicle load, the road cross-section and the selected style of driving. To perform overtaking, you need to press the accelerator pedal. At that, the gearbox will be automatically switched to a lower gear depending on the vehicle current speed. The

vehicle will start to accelerate, using overall engine power.

Starting off and backing run

Press the brake pedal and, pressing lock button, shift the gear change lever to position **R**, at the same time you will feel a little push, release the brake pedal and slowly pressing the accelerator pedal, start driving.

Starting off and driving on slippery road

On slippery roads and roads, pavement of which does not provide firm wheel gripping, to avoid wheel spin and power loss, you should start off pressing the accelerator pedal in a careful, slow manner.

Warning

The accelerator pedal sudden pressing may result in the loss of grip and even of the vehicle drift.

ATTENTION!

Long wheel slip, when starting off or picking up, could cause serious damage to the transmission and subsequent costly repairs.

Stopping the vehicle

After complete stop of the vehicle, keeping your foot on the brake pedal, shift the gear change lever to position **P**, thereupon, the gearbox is switched to neutral gear, and the traction wheels are mechanically locked by the transmission.

ATTENTION!

Never attempt to move the gear change lever to position P while driving the vehicle. This will lead to serious mechanical damage and loss of vehicle drivability.

Driving in economy mode

Button «Overdrive» **O/D (ON-OFF)** is located on the decorated the lever board.

ON – economy driving mode on-position (overdrive gear). It is switched on with button **O/D**, when the gear change lever is in position **D**, if it is necessary to drive in economy mode in the country conditions. Overdrive gear will not be turned on if the engine has not been warmed up to operating temperature.

OFF – economy driving mode off-position. Overdrive off indicator is

located in the instrument cluster. This position is used when driving on long and flat grades where the engine braking, as well as sportive and dynamic driving are necessary.

For example, when driving at low speed or overcoming low grades the gearbox can periodically be switched to overdrive and back. You can feel little bumps when the gearbox changes the gears. In this case, press button **O/D** to switch off the overdrive gear (position – **OFF**).

When the driving conditions are changed, press button **O/D** to switch on the overdrive gear **ON**. The overdrive off indicator in the instrument cluster will go off.

ATTENTION!

It is not recommended to drive at high speed on roads in suburban areas for a long time with the overdrive gear off (position – OFF), as this increases fuel consumption.

Short-term stops

During short-term stop, for example, at the traffic lights, it is not necessary to shift to position **N** and, moreover, to **P**. It is enough to hold on the

vehicle by means of the brake pedal. Thereupon, the engine will run at idle.

Parking

The vehicle should be fully stopped. Actuate the parking brake and then put the gear change lever to parking position **P**. Due to this procedure, especially on grades, the locking mechanism will not be too loaded and then it will be easily to change the lever from this position.

Starting upgrading

Actuate the parking brake on the vehicle and shift the gear change lever to position **P**.

Press the brake pedal, start up the engine. Shift the gear change lever to position **D**, after a while transmission will come to operation, and the vehicle will be retained on the grade, releasing the parking brake, press the accelerator pedal, start driving. The vehicle should start moving smoothly, without rolling. If short-term stop on the grade is necessary (drive control in position **D**), control the vehicle and hold it down with the engine torque or apply the parking brake.

Starting off the vehicle in reverse gear on the descent

Actuate the parking brake on the vehicle and shift the gear change lever to position **P**.

Press the brake pedal, start up the engine. Shift the gear change lever to position **R**, after a while transmission will come to operation, and the vehicle will be retained on a grade, releasing the parking brake, press the accelerator pedal, start driving. The vehicle should start moving smoothly, without rolling.

Warning

On high grade when driving forward (the gear change lever in position **D) and on rapid descent driving in reverse (the gear change lever in position **R**) efficiency of the engine torque transmitted to the wheels will not be enough, that's why you will be able to hold on the vehicle with the foot or parking brake. Conversely, on high grade when driving in reverse (the gear change lever in position **R**) and on rapid descent when driving forward (the gear change lever in position **D**) the torque transmitted**

to the wheels would be redundant, and the use of the foot or parking brake is necessary.

Emergency mode of automatic transmission

Automatic transmission can change to emergency operation mode (in this case the third gear is switched on) if the vehicle drives under very difficult conditions. For example, when intensive slipping is combined with emergency braking. This can take place even with a fully operational system of the automatic transmission. In this case, it is necessary to switch off the ignition and wait for 3 seconds. Then switch on the ignition again: the vehicle must return to standard operation mode.

If the automatic transmission continues to stay in the emergency mode, contact SSNE certified by the manufacturer.

Unlocking the gear change lever in the gearbox

When the storage battery is discharged the gear change lever cannot be shifted from position **P**, even if

the lever button is pressed with the brake pedal depressed.

To shift the gear change lever you should press the unlocking button, located under the decorative cover of the lever on the actuator drive housing in front to the right of the lever, with left hand thumb.

Now you can switch the gear change lever from position **P** to position **N**.

In order to ensure safety during the operation, actuate the parking brake and hold down the brake pedal.

If you face the problems when changing the gear change lever of the automatic transmission from position **P** (parking), having fulfilled all these operations, address the certified SSNE.

Recommended methods of towing a vehicle equipped with automatic transmission

The manufacturer recommends to tow the vehicle equipped with the automatic transmission, without tracking wheels bearing by the method of complete loading on a vehicle carrier with a platform.

ATTENTION!

It is not allowed to tow the vehicle equipped with the automatic transmission, with bearing of front or all four wheels to the road surface, as this may cause serious damage to the transmission and subsequent costly repairs. By way of exception, you may tow the vehicle with the bearing of all the wheels to the road surface if the transmission is in order and the control drive is in position N with a maximum speed of 20 km/h at a distance of not more than 20 km. If it is necessary to tow the vehicle with raised rear wheels, the front wheels must be supported by a special trolley.

VEHICLE TECHNICAL MAINTENANCE AND CURRENT REPAIR

This section provides a brief description of some kinds of operations on the vehicle technical maintenance and current repair.

Full technique of maintenance, repair and scrapping of vehicles can be provided by manufacturer certified SSNE, equipped with special equipment and tooling. Your vehicle technical maintenance and repair should be carried out in strict compliance with the requirements of your vehicle log book.

All operations in the engine compartment must be carried out after opening the bonnet (see Section «Bonnet»).

ENGINE LUBRICATION SYSTEM

With the engine running, the engine oil consumption is a normal phenomenon. The value of oil consumption depends on driving style of the vehicle

and it is determined by the engine load and the engine shaft speed. In the initial operating period the oil consumption is slightly increased.

Therefore, you should regularly, especially before long trips, check the oil level in the engine case.

The oil level is checked in a cold dead engine when the vehicle is located on a horizontal surface. The level should be between **MIN** and **MAX** oil level indicator 1 (Fig. 45). If necessary, top up the oil (see Appendix 1) through the filler, closed by plug 2.

In 16-valve engine the oil level indicator handle 1 is brought even with the upper engine cover. The oil level should be from upper to lower score edge on the indicator.

After topping up the oil level should be checked no sooner, than in three minutes to give topped up portion of the oil time to drain into the engine case. To measure the oil level properly you should insert indicator 1 to its mounting hole until it stops.

ATTENTION!

Do not exceed the oil level in the engine case above MAX mark of oil level indicator 1.

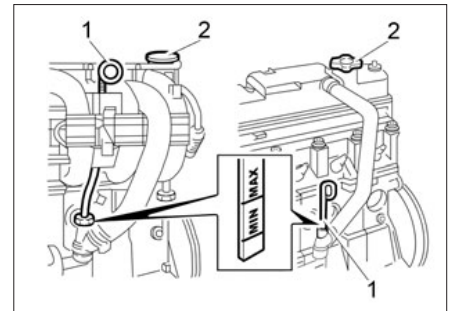

Fig. 45. Engine case oil level checking

Otherwise, the oil will enter the combustion chamber through the engine case ventilation system and together with exhaust gases will be emitted into the atmosphere, and oil combustion products may result in the catalytic converter failure.

During forced operation in winter, under negative temperature conditions combined with predominance of urban traffic, the oil change in the engine is recommended to make twice more often than specified in the vehicle log book.

GEARBOX

Check the oil level in the cooled gearbox. The oil level should be between two oil level gauge 1 marks (Fig. 46a). Top up the oil (see Annex 1) in small portions through inspection hole closed by the oil level gauge.

Drain the used oil through the hole closed with plug 2.

ATTENTION!

Installation of the dipstick for oil level control in the gearbox should be made up to the dipstick handle flange stop to inspection hole lug boss, with no dipstick skew.

In the design variant, when the vehicle is equipped with mechanical gear box and cable-operated actuator, the oil level should be according to the inspection hole 1 lower edge (Fig. 46b). Top up the oil (see Appendix 1) in small portions through the inspection hole.

ATTENTION!

Use only semi-synthetic oil Tatneft' TM-4-12 SAE 75W-85

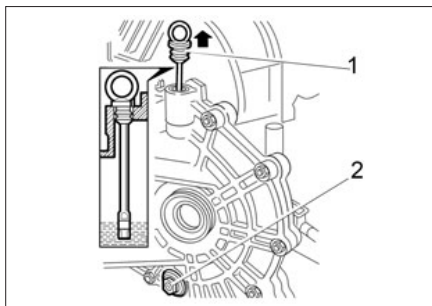

Fig. 46a. Gearbox oil level checking

GL-4 in the mechanical gearbox with cable-operated actuator.

Drain the used oil through the hole closed with plug 2.

Working automatic transmission fluid (ATF)

The working fluid in the automatic transmission is filled by the manufacturer for the whole vehicle service life.

It is recommended to check the level and replace the working fluid (if necessary) at the SSNE certified by the manufacture.

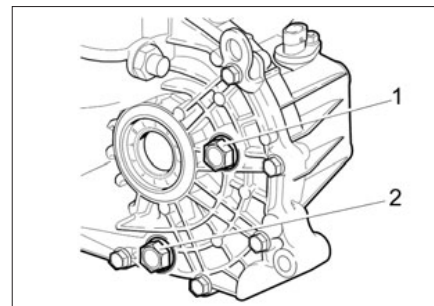

Fig. 46b. Gearbox oil level checking (in the design variant)

ATTENTION!

For automatic transmissions use only the original fluid NISSAN ATF Matic-S or EJ-1. The use of other fluid types will lead to a failure of the automatic transmission operation and its service life reduction; it also can cause malfunctions, removal of which is not covered by the warranty of the manufacturer.

Automated gearbox

When a vehicle is equipped with automated gearbox the movement is performed only by pressing acceler-

ator and brake pedals. The first gear in all cases is the standard gear for starting.

After the start-up of engine, shifting selector to **R**, **A** or **M** positions and moving the foot from the brake pedal to the accelerator pedal, releasing of the handbrake (if it is on) and pressing the accelerator pedal the car starts moving. Gear changing in **A** mode is performed fully automatically.

The driver can use the gear change lever (Fig. 47) to terminate the automatic mode at any time for manual intervention in the automatic drive system. The driver can keep the actual gear or can downshift or upshift manually. If upshifting or downshifting leads to the increased engine speed the wrong gear shifting could be blocked.

The following information about the robotic gearbox operation is displayed on the instrument panel:

- engaged gear,
- automatic or manual mode (**AUTO** or **MANUAL**),
- brake pedal operation condition.

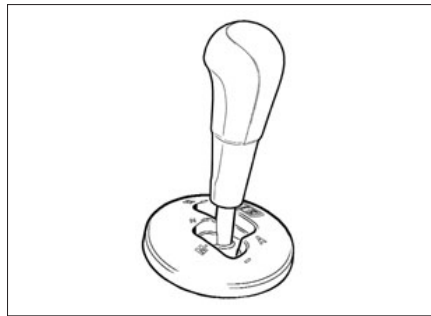

Fig. 47. Gear change lever

Automated gearbox gear change lever

Gear change lever has got 2 lines (Fig. 48) – one for shifting from neutral position (**N**) to reverse (**R**) or automatic mode (**A**) and the second is for upshifting or downshifting in manual mode (**M**). Two lines are linked together for the switching between automatic mode (**A**) and manual mode.

Manual mode (**M**) can be activated only from automatic mode (**A**). Reverse gear (**R**) can be activated only from neutral position (**N**).

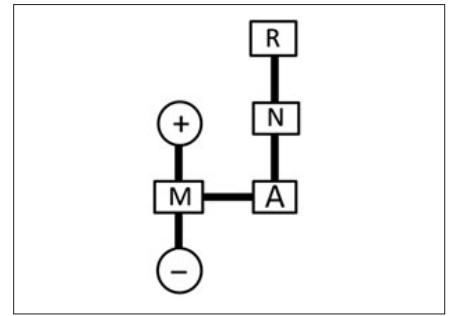

Fig. 48. Gear change lever scheme

Upshifting (+) or downshifting (-) is possible only in manual mode (**M**).

(**N**), (**R**), (**A**), (**M**) positions are fixed, (+) and (-) positions are not fixed.

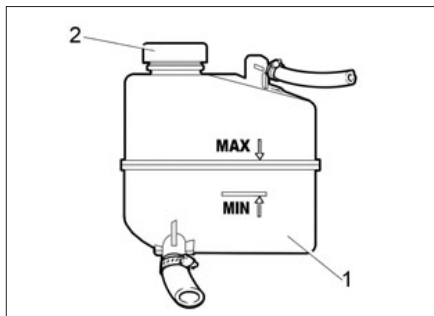

Fig. 49. Expansion chamber

ENGINE COOLING SYSTEM

Check the coolant level in expansion chamber 1 (Fig. 49) only in the cold engine. The coolant level must be between **MIN** and **MAX** marks applied on the housing of the expansion chamber, which is made of translucent material providing visual control of the fluid level. While the vehicle operation the coolant level in the expansion chamber can be lowered. Top up the coolant (see Appendix 1) through the hole closed with plug 2. After topping up the fluid the plug must be tightly turned up, as the expansion chamber with the

engine running and warmed up is under pressure.

Warning

To avoid burns, you should open the plug of the expansion chamber for topping up the coolant only in the cold engine.

In cases when the coolant level is constantly dropping and you often have to refill the coolant, refer to any certified SSNE.

BRAKE SYSTEM

The brake fluid level in reservoir 3 (Fig. 50), installed on the brake master cylinder, visually check according to the marks on the reservoir housing made of translucent plastic. With cover 2 and sensor 1 of the emergency brake fluid level removed and the new brake shoe linings, the brake fluid level must be on the mark **MAX**. After installing cover 2 and sensor 1 the brake fluid level should be at the lower edge of the reservoir filler.

If the hydraulic brake system is in good condition, the fluid level lowering in the reservoir may be due to wear of brake shoe linings. The fluid

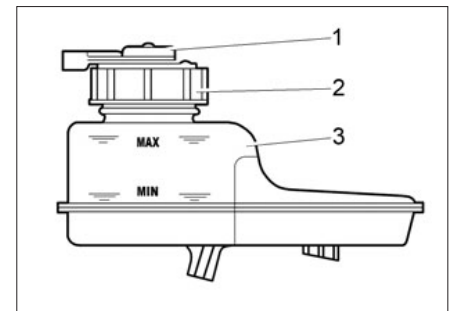

Fig. 50. Hydraulic brake actuation fluid reservoir

level lowering to **MIN** mark indirectly indicates their extreme wear. In this case it is necessary to check the state of linings, and there is no necessity to top up the brake fluid in the reservoir, because during the new pads installation the fluid level in the reservoir will raise to normal.

«Brake failure» signal indicator flashes, when the brake fluid level in the reservoir lowers below **MIN** mark, that with partially worn or new brake shoe linings indicates the loss of system integrity and fluid leakage. In this case top up fluid (see Appendix 1) only after restoring the system leak-tightness at any certified SSNE.

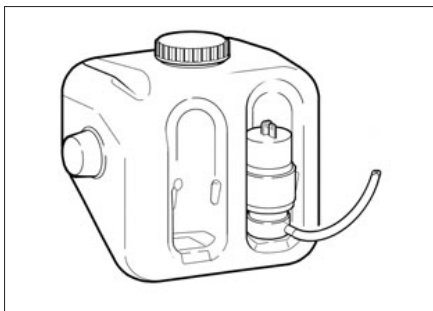

Fig. 51. Windshield washer reservoir

While checking the brake fluid level in the reservoir, do not either forget to check the brake fluid emergency level sensor for normal operation, for what press down the centre of the protective sensor 1 cap – with the ignition on, the «brake failure» alarm indicator should flash red in the instrument cluster.

WINDOW WASHER SYSTEM

The windshield washer reservoir (Fig. 51) should always be filled with window-washer fluid, top up the fluid (see Appendix 1) through the hole closed with the plug.

In warm it is allowed to use clear water, and at sub-zero temperature use only special window-washer fluids (see Appendix 1).

ATTENTION!

At an ambient temperature of 0°C and below it is not allowed to pour water into the windshield and rear window washer reservoir without special washer fluids because of possible damage to the washer pump.

Replacing wiper blades

To replace the wiper blades perform the following operations:

- pull up the wiper arm from the windshield;
- turn the blade on the axis of rotation, placing it approximately perpendicular to the wiper arm preliminarily unlocking the blade on the arm (by pressing the adapter projec-

tion between the blade and the arm), remove the blade from the arm.

Install the new blade in reverse order.

ATTENTION!

1. To ensure good visibility through the windshield keep the wiper blades in perfect condition.

2. To avoid the blades deformation you should regularly clean the wiper blades with fluid from the washer reservoir. When the windows and the wiper blades are severely contaminated, for example, with remnants of insects (adhering to the window), road salt, elements of the road surface, you should clean the window outer face and the blades with a soft cloth using special detergents. After cleaning wash the window and the wiper blades with clear water.

3. Given that the windshield wipers are connected with the traffic safety system, it is recommended to replace the wiper blades during constant vehicle operation every six months.

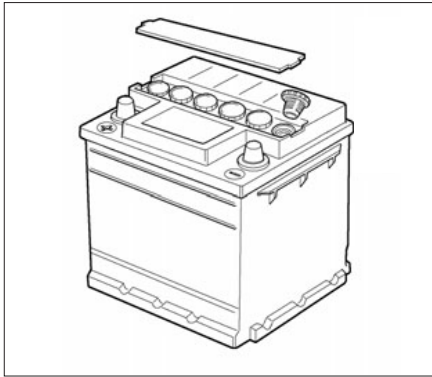

Fig. 52. Storage battery

STORAGE BATTERY

You should check the level of the electrolyte in the storage battery regularly. The electrolyte level must be between **MIN** and **MAX** marks (Fig. 52) on the semi-transparent battery case. It is prohibited to use battery when the electrolyte level is below the line with mark **MIN**.

If there are no **MIN** and **MAX** marks on the battery case, or is the battery case is opaque, then the electrolyte level should be 10-15 mm over the separators top border.

Warning

Due to the fact that the electrolyte is a corrosive fluid and its impact harmful for You and the vehicle components, it is advisable to carry out the storage battery maintenance at the certified SSNEs.

Do not let the battery run low and recharge it when necessary.

If the storage battery has electrolyte density and level indicator («spyhole»), then the battery status can be determined by its colour:

- «Spyhole» is green – electrolyte level and density are normal;
- «Spyhole» is black – it is necessary to charge the battery;
- «Spyhole» is white – electrolyte level is too low.

If the battery has no «spyhole», the charging status can be determined by measuring voltage on battery terminals: voltage (with no load) must be not less than 12.6 V (which corresponds to 75% of charge at temperature 25°C).

You should regularly check the charging status of the storage battery in the following cases:

- If you use your car mostly for short city drives.

TIRES AND WHEELS

Check the tire air pressure with pressure gage periodically. Operation of tires with pressure different from the recommended (see Table 3), leads to their premature wear, as well as to stability reduction and the vehicle drivability deterioration. If constant drop of air pressure in tires is present, check for air leakage through the valve inside. In case of air leakage tighten the valve inside, and if that does not work, replace it with the new one.

If the pressure drops with the operative valve inside, then you need to repair the tire.

To ensure even tire wear swap the wheels as shown in Fig. 53 according to the instructions of the vehicle log book.

When driving, avoid grinding wheels in curbs and fast driving on roads with disturbed surface (bumps, potholes, etc.) as damage to the wheel rim can cause not only imbalance, but also loss of pressure in tubeless tires. If you feel vibrations while driving, check the wheels for their balancing at any certified SSNE.

Warning

Never lift a car by lifting jack when the wheels are not braked

Table 3

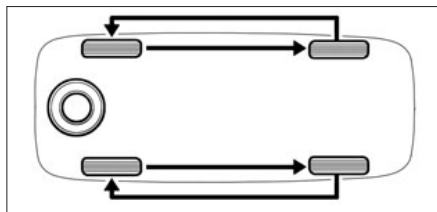

Fig. 53. Wheel rotation pattern

and stay under the car, lifted by jack.

The jacking pad is designed for works on hard surface or grounds. To avoid the jack falling into eroding, loose grounds, snow, quicksand and etc. we recommend to place a piece of board, plywood or another firm material not less than 250 x 250 mm.

Tire pressure monitoring system

Car is equipped by the tire pressure monitoring system (TPMS).

The system consists of four sensors installed in car wheels, control unit being the receiver of the signal and indicator in cluster. The replacement of the sensors and system learning are to be done only in the authorized sale and service network.

Lighting of yellow TPMS (⚠) indi-

Modification and version of the vehicle		Tire dimensions with load and speed indices*	Wheel dimensions		Air pressure in tires, front/rear, MPa (kgf/cm ²)		
			rim width (in inches)	rim offset (ET)**, mm	partial load***	full load****	
Set by manufacturer							
2190 («sedan»)	Standard	175/70R13 82T, H	5J	35	0,19 /0,19 (1,9/1,9)	0,19/0,21 (1,9/2,1)	
	Norm	175/65R14 82H	5½J		0,2/0,2 (2,0/2,0)	0,2/0,22 (2,0/2,2)	
	Luxe	175/65R14 82H					
		185/55R15 82H	6J				
2191 («liftback»)	Standard	175/65R14 82H	5½J		35	0,2/0,2 (2,0/2,0)	0,2/0,22 (2,0/2,2)
	Norm	185/60R14 82H	5½J, 6J				
	Luxe	175/65R14 82H 185/60R14 82H 185/55R15 82H					
Allowed to be set during operation							
2190 («sedan»)	Standard	175/70R13 82T, H	5J	35	0,19 /0,19 (1,9/1,9)	0,19/0,21 (1,9/2,1)	
	Standard Norm Luxe	175/65R14 82T, H 185/60R14 82T, H 185/55R15 82T, H	5J, 5½J, 6J		0,2/0,2 (2,0/2,0)	0,2/0,22 (2,0/2,2)	
2191 («liftback»)	All modifications	175/65R14 82T, H 185/60R14 82T, H 185/55R15 82T, H,V					

* Speed indexes: T – up to 190 km/h, H – up to 210 km/h, V – up to 240 km/h.

Load indexes: 82 – 475 kg.

** Offset (ET) – distance from the joint face of the disc to the midpoint of the rim.

*** Partial load – no more than 3 adults in the vehicle without load in the trunk.

**** Full load – more than 3 adults in the vehicle or 3 adults with 50 kg load in the trunk.

Allowed to use winter tires (M + S) of the above dimensions and index Q with corresponding restriction of the maximum vehicle speed (up to 160 km/h).

cator shows the critical decrease of the pressure in one or several tires. Continuation of driving with such a

low pressure in the tires could lead to their overheating and mechanical destruction. Exploitation of the tires

with the pressure lower than normative results in worsening of car ride and handling, braking performance as well as impacts the increase in fuel consumption and reduces tire life.

If indicator turned on, it is necessary to stop the car following all precautions, check the tire status and put their pressure level to the normal status. Tire pumping shall be done with ignition on with the pressure 2,2–2,3 atm after this the indicator shall turn off. If the indicator remains on, it is necessary to recheck and pump other car tires till the indicator turns off. After the indicator turns off it is necessary to lower the tire pressure to the values recommended by the car manufacturer. If it is not possible to secure the appropriate tire pressure it is necessary to replace the disabled wheel by spare one.

Attention! Spare wheel is not equipped by TPMS sensor and in case of its usage the indicator will be on, it is necessary to drive carefully till the elimination of malfunction.

Pay attention that the application of TPMS system does not mean that there is no need for correct servicing of tires and maintaining the appropriate pressure in them even if the decrease of the level is not enough to turn the TPMS indicator on.

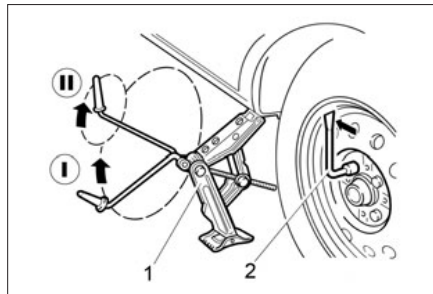

Fig. 54. Lifting the vehicle when replacing the wheels

The (II) indicator is also used to alarm about failure in the TPMS system. When the system detects failure the indicator twinkling 5 times with the frequency Hertz then continues permanent lighting.

The indication on the failure in the TPMS system is done each time when ignition turns on till the failure exists. When the failure indicator turned on, the system probably will not be able to detect or indicate low pressure in the tires as it is aimed for. The failure in TPMS system could be caused by different reasons including the installation or replacement of tires or wheels.

Always check the TPMS failure indication after the replacement of one or several tires, wheels or the

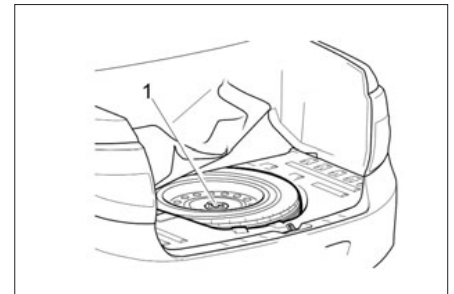

Fig. 55. Packing the spare wheel

place of their installation in the car to be sure in operation ability of the TPMS system.

Replacing the wheels

To replace wheels:

- put the vehicle on a level surface and brake it with the parking brake and the first gear on;
- take the spare tire and tools;
- remove the wheel cover (**in the design variant**);
- loosen the replaced wheel fastening bolts with combination wrench 2 (Fig. 54) for one turn;
- set lifting jack 1 so that the recess in the jacking pad is inserted to the edge of the sill closer to the wheel that is replaced, and the foot of the jack is

just under it. To facilitate the jack correct installation location, special holes for the lifting jack are provided on the vehicle sills. By rotating the jack handle (position I) lift the wheel above the support surface to a height of 50-60 mm. If the distance to the support surface does not provide a complete turn of the handle, then rotate the handle with small radius (position II);

- unscrew the bolts and remove the wheel. Mount the spare wheel, turn in the bolts and tighten them evenly crosswise;

- lower the vehicle and remove the jack. Tighten the bolts and check the tire pressure.

When finished, lay the replaced wheel in the luggage compartment bay, secure it with screw 1 (Fig. 55) and cover with the mat.

After the vehicle first 1000 km run it is necessary to check the torque-turn wheel bolt tightening, tighten if required. Perform the same operation during every new wheel installation on the vehicle.

In the design variant the built-up steel spare wheel is used on the vehicles alloy wheels.

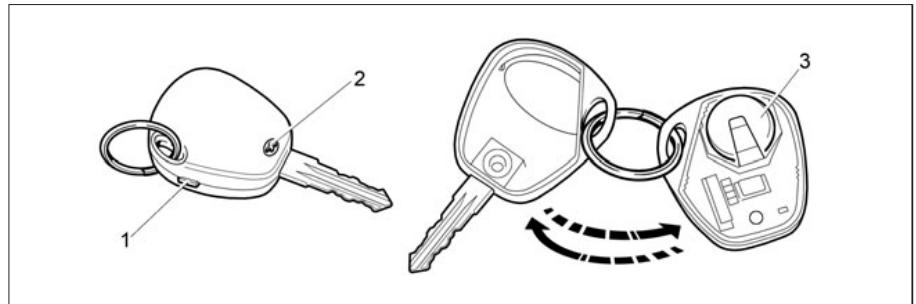

Fig. 56. The remote control battery replacement

REMOTE CONTROL BATTERY REPLACEMENT

The remote control contains a lithium battery of CR2032 type with the initial voltage of 3 V. If the voltage of the remote control is normal, then every time you press any button on the remote control panel its indicator will light with short flash. If at pressing any button of the control panel the indicator lights with two short flashes or does not light at all, the battery should be replaced with a new one. To do this, perform the following operations:

- open cover (Fig. 56) on the control panel, shifting it in the arrow direction;

- remove the battery sealer;
- replace the battery 3 with the new one observing the polarity;
- close the battery sealer 2;
- slide the cover 1 in on the control panel case.

FUSE PLUG REPLACEMENT

When replacing the fuse plugs, use only new fuses the types of which are recommended for your vehicle, and only of those manufacturers who own the conclusion of JSC «AVTOVAZ» and bear the marking in accordance with Table 4-7.

ATTENTION!

Use of fuses that differ in amperage rating from those recommended in Table 4 is not allowed. This can lead to a failure of the vehicle's electrical equipment or fire hazard.

To access the fuse box with fuse plugs (Fig. 57) pull the lower left edge of the cover and release the left cut-off point 1, then release the middle lower cut-off point 2 and the right lower cut-off point 3, then the upper cut-off points 4, 5 and remove the cover. The cover installation is performed according to procedure as follows: insert the holding lock 6 into instrument panel opening and, beginning from the right lower edge, lock the cover lower fastenings in points 3, 2, 1, and then the upper

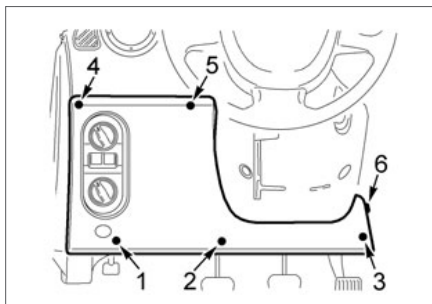

Fig. 57. Opening the setup block

fastenings in points 4 and 5. Watch after accurate striking of the cover fastenings into metallic holding locks, installed in the instrument panel.

Current strength that the fuse is designed for, is indicated on its face, and the fuse number is indicated on the fuse box housing.

During the fuse block cover re-installation, make sure of the wire harness shoe reliable connection to the trunk lid latch actuator switch and of no wire pinches.

In case of repeated failure of the fuse, to locate and eliminate the cause of its melting, refer to any SSNE certified by the manufacturer.

Table 4

**Electric circuits protected by fuses located within fuse block and relay of the vehicle passenger compartment
in «Luxe» version***

Fuse No	Current force	Protected circuit
F1	15A	Ignition coil
		Nozzles
		EMS control unit
F2	30A	Body electronics mainframe
F3	10A	Body electronics mainframe
		Warning light switch
F4	15A	Air bags controller
		Rain sensor
F5	7,5A	Terminal clamp – 15 devices
F6	7,5A	Backup light
		Backup light relay
		Parking Assist System control unit
F7	7,5A	Adsorber blowdown valve
		Mass airflow sensor/pressure sensor
		Phase sensor
		Oxygen sensor
		Tire Pressure Monitoring System control unit
F8		Reserve
F9	5A	Right side parking lights
F10	5A	Left side parking lights
		Instrument panel and buttons illumination
		License plate lamp
		Trunk compartment lamp
		Glove box lamp
F11	5A	Rear fog light
F12	10A	Low beam, RH lamp

Extension of table 4

Fuse No	Current force	Protected circuit
F13	10A	Low beam, LH lamp
F14	15A	Socket to connect additional devices in the trunk
F15	10A	Rear window wiper
		Rear window washer
F16	5A	Driver door module
F17		Reserve
F18		Reserve
F19		Reserve
F20		Reserve
F21	10A	High beam, RH lamp
F22	10A	High beam, LH lamp
F23	10A	RH fog light
F24	10A	LH fog light
F25	15A	FR seats heating
F26	5A	ABS control unit/ESP control unit
F27	15A	Cigar lighter
F28	15A	Fuel pump
F29	20A	Body electronics mainframe
		Windshield wiper
		Windshield washer
F30		Reserve
F31	7,5A	Air conditioner compressor clutch
F32	7,5A	Stop signal
		Automatic gearbox controller
F33	25A	ABS control unit/ESP control unit
F34	5A	Instrument cluster
		Diagnostic connector
F35		Reserve
F36	10A	Audio signal (horn)

Extension of table 4

Fuse No	Current force	Protected circuit
F37	10A	Multimedia system
F38		Reserve
F39		Reserve
F40		Reserve
F41	50A	Windshield heater
F42		Reserve
F43	50A	Robotized gearbox controller
F44	30A	Heater electric fan
		Climate control system controller
F45	25A	Rear window defroster
		Outside mirrors defroster
F46		Reserve

* It is specified the set of fuses for the top level of equipment – «Luxe» (depending on the set of options selected some fuses of this set in other versions may not be used).

Table 5

Electric circuits protected by fuses located within fuse block and relay of the vehicle passenger compartment in «Norm» and «Standard» versions

Fuse No	Current force	Protected circuit
F1	15A	Ignition coil
		Nozzles
		EMS control unit
F2		Reserve
F3	15A	Alarm signaling
F4	20A	Windshield washer
		Windshield wiper

Extension of table 5

Fuse No	Current force	Protected circuit
F5	7,5A	Terminal clamp – 15 devices
F6	7,5A	Backup light/Backup light relay*
		Turn indicators
F7	7,5A	Adsorber blowdown valve
		Mass airflow sensor/pressure sensor
		Phase sensor
		Oxygen sensor
		Tire Pressure Monitoring System control unit*
F8		Reserve
F9	5A	Right side parking lights
F10	5A	Left side parking lights
		Instrument panel and buttons illumination
		License plate lamp
		Trunk compartment lamp
F11	5A	Rear fog light
F12	10A	Low beam, RH lamp
F13	10A	Low beam, LH lamp
F14	15A	Socket to connect additional devices in the trunk
F15	10A	Rear window wiper*
		Rear window washer*
F16		Reserve
F17		Reserve
F18		Reserve
F19		Reserve
F20		Reserve
F21	10A	High beam, RH lamp
F22	10A	High beam, LH lamp
F23	10A	RH fog light
F24	10A	LH fog light
F25	15A	FR seats heating*

Extension of table 5

Fuse No	Current force	Protected circuit
F26	5A	ABS control unit/ESP control unit
F27	15A	Cigar lighter
F28	15A	Fuel pump
F29	15A	Door lock blocking motor-reducer
		Trunk lock blocking motor-reducer
F30	10A	Day time running lights
F31	7,5A	Air conditioner compressor clutch*
F32	7,5A	Stop signal
		Automatic gearbox controller*
		Passenger compartment lamp
F33	25A	ABS control unit/ESP control unit
F34	5A	Instrument cluster
		Diagnostic connector
F35	15A	Air bags control unit
F36	10A	Audio signal (horn)
F37	10A	Multimedia system
F38		Reserve
F39		Reserve
F40		Reserve
F41	50A	Windshield heater *
F42	30A	FR door electric window lifters *
F43	50A	Robotized gearbox controller *
F44	30A	Heater electric fan
		Climate control system controller *
F45	25A	Rear window defroster
		Outside mirrors defroster*
F46		Reserve

* For «Norm» version of equipment with options.

Table 6

Relay located within fuse block and passenger compartment relay in «Luxe» version*

Relay No	Relay output capacity	Switched circuit
K1	50A	Load reduction relay of the ignition switch
K2	30A	Starter relay
K3	40A	Radiator electric cooling fans relay
K4	30A	Radiator electric cooling fans relay
K5	30A	Air conditioner compressor clutch relay
K6	30A	Rear window and outside mirrors defroster relay
K7	20A	High beam relay
K8	20A	Audio signal (horn) relay
K9	20A	Low beam relay
K10	20A	Backup light relay
K11	20A	Electronic engine management system main relay
K12	20A	Fuel pump relay
K13	20A	Seats heating relay
K14	70A	Windshield heating relay
K15		Reserve
K16		Reserve
K17		Reserve
K18		Reserve

* It is specified the set of relays for the top level of equipment – «Luxe» (depending on the set of options selected some fuses of this set in other versions may not be used)

Table 7

Relay located within fuse block and passenger compartment relay in «Norm» and «Standard» versions

Relay No	Nominal	The function of relay
K1	50A	Load reduction relay of the ignition switch
K2	30A	Starter relay
K3		Wiper relay
K4	30A	Radiator electric cooling fans relay
K5		Turn indicators and alarm signaling relay
K6	30A	FR electric window lifters relay*
K7	20A	High beam relay
K8	20A	Audio signal (horn) relay
K9	20A	Low beam relay
K10	20A	Backup light relay
K11	20A	Electronic engine management system main relay
K12	20A	Fuel pump relay
K13	20A	Seats heating relay*
K14	70A	Windshield heating relay*
K15	30A	Rear window and outside mirrors defroster relay
K16	30A	Air conditioner compressor clutch relay *
K17		Reserve
K18	40A	Radiator electric cooling fans relay *

* For «Norm» version of equipment with options.

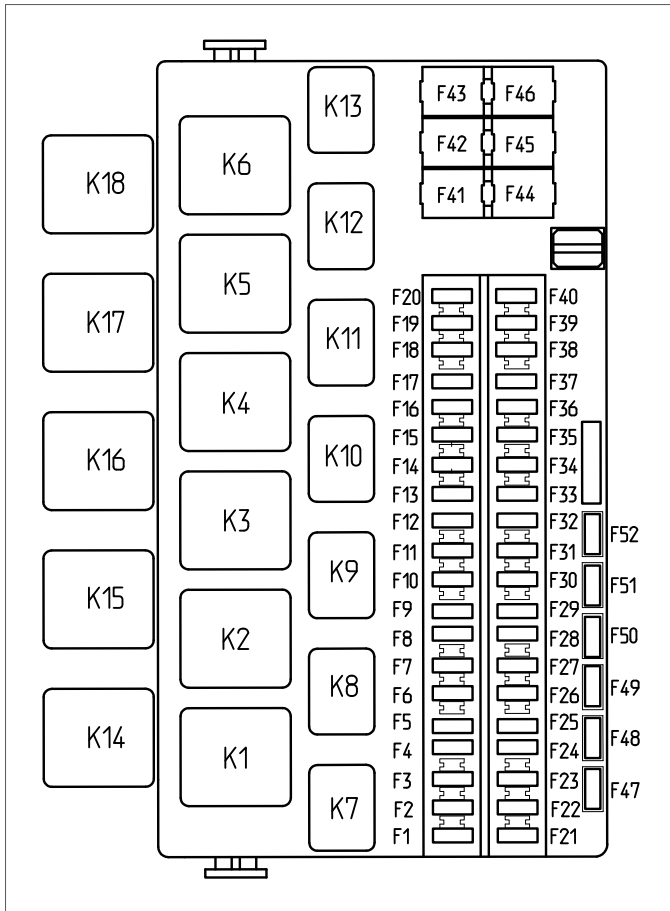

Fig. 58. Fuse block and relay of passenger compartment

BULB REPLACEMENT

For normal operation of the lighting and light alarm system, use the bulbs as defined in Appendix 2.

Headlight unit

To access the dipped/main beam bulb, remove the protective cover 2 (Fig. 59), disconnect the terminal block and remove the lamp rubber housing, in turn, pull aside the «lugs» 4 of the bulb holder spring, after pressing them remove the bulb 5 out of the reflector mounting bracket. The new bulb installation should be carried out in reverse order. All operations on installing a halogen bulb should be carried out with gloves to prevent leaving traces on the bulb. After the dipped/main beam bulb installation make sure in tight fitting of the rubber housing in the bulb socket and headlight unit case.

To remove the tail light/day-time running bulb perform the following operations:

- in the right headlight unit turn the bulb holder 1 counter-clockwise;
- in the left headlight unit, first, throw the the air filter casing backwards and turn the holder 1 counter-clockwise;

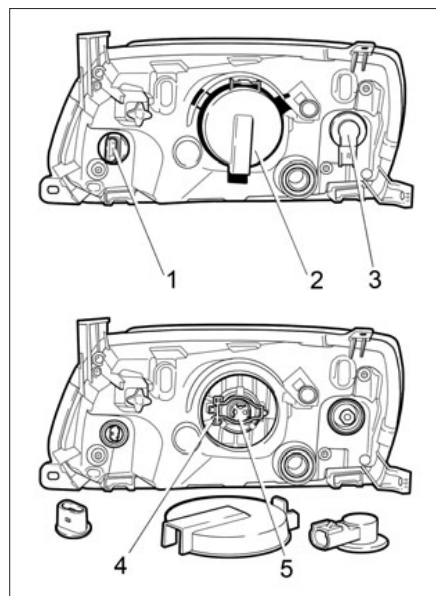

Fig. 59. Headlight unit

- dismantle the bulb out of the holder.

The new bulb installation should be carried out in reverse order.

To remove the turn indicator bulb perform the following operations:

- remove the turn indicator bulb-holder 3 out of the headlight unit mounting bracket turning it clockwise;

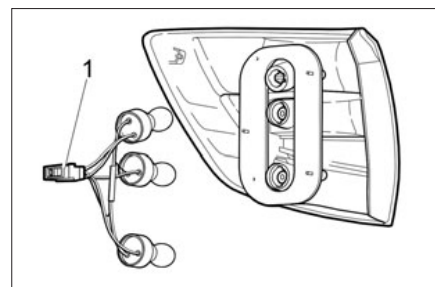

Fig. 60a. Rear light

- in the left headlight unit, remove the turn indicator bulb-holder 3 out of the mounting bracket pressing and turning the holder counter-clockwise;

– dismantle the bulb out of the holder, first depressing the bulb in the holder and turning it counter-clockwise.

The new bulb installation should be carried out in reverse order.

Rear light

To remove the bulb in the rear light (Fig. 60a) perform the following operations:

- open the trunk compartment lining access hole (on sticker), located in the rear light installation area;

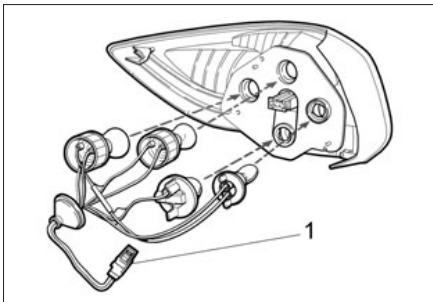

Fig. 60b. Rear light in «liftback» vehicle

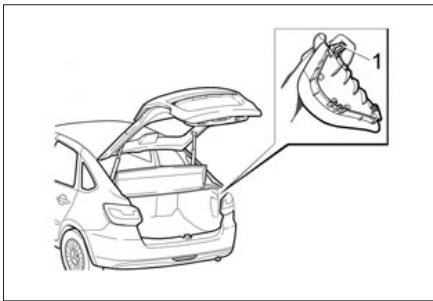

Fig. 60c. Shelf support clip removal

- turning the bulb holder counter-clockwise, remove it out of the mounting bracket;
- remove the bulb out of the holder pressing and turning it counter-clockwise.

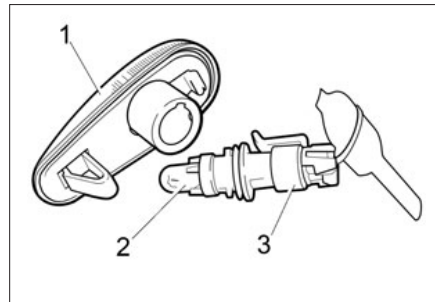

Fig. 60d. Side turn indicator

The new bulb installation should be carried out in reverse order.

To remove the bulbs in the rear light, «liftback» vehicle (Fig. 60b) you shall:

- open the tailgate;
- press finger to the latch 1 (Fig. 60c) through the hole in shelf support clip;
- pull the shelf support clip;
- heave the shelf support clip for release lower hooks so to make the access to rear light available;
- turned the replaced bulbs socket counterclockwise, remove it from the seat;
- remove bulbs from the socket turning it counterclockwise.

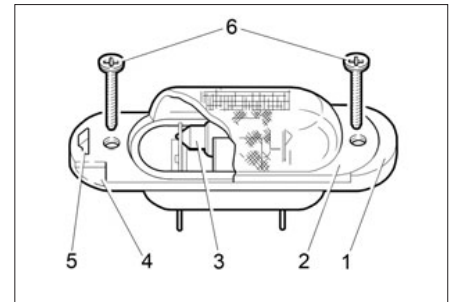

Fig. 61a. Number-plate light

Side turn indicator

To remove the bulb in the Side turn indicator 1 (Fig. 60d) remove it from the vehicle. In the socket the light is held with spring latch and the holding lock. Move the light in the driving direction and throw out the holding lock out of engagement. Turning the bulb holder 3 counter-clockwise remove it in assembly with the bulb from the light housing and pull bulb 2 to yourself.

Number-plate light

Change the burned-out bulb 3 (Fig. 61a) in the number-plate light

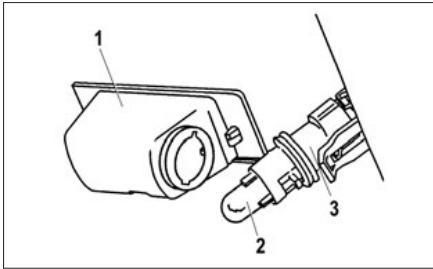

Fig. 61b. Licence plate light in «liftback» vehicle

only after its removal from the vehicle, for this loosen screws 6, insert a screwdriver into chase 4, press to the centre of latch 5 and carefully remove headlight glass 2 with the screwdriver. Bulb 3 in housing 1 is held with spring contacts. To replace light bulb 1 (Fig. 61b) in the licence plate light, «liftback» vehicle, you should remove the light from the vehicle.

In the socket the light is held with spring latch and striker plate.

Insert a flat screwdriver into chase on the light left side of the roof light, carefully move it to the right and throw out the striker plate of engagement. Turning socket 3 counterclockwise, remove it and the bulb from the light housing 1 and pull bulb 2.

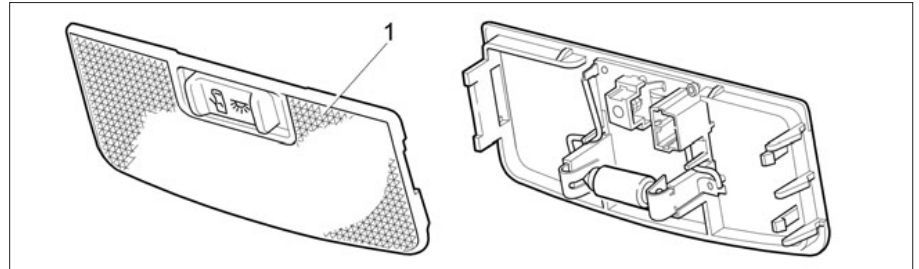

Fig. 62. Interior ceiling light

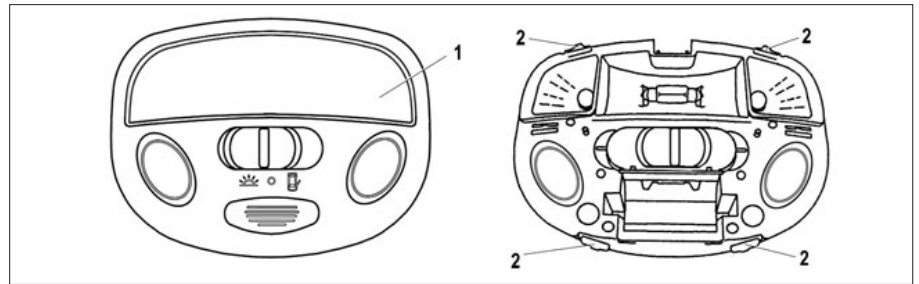

Fig. 63. Interior illumination unit

After replacing the bulb the assembly and installation of the licence plate light should be carried out in reverse order.

Interior ceiling light

To replace the bulbs in the interior ceiling light you should remove head-

light lens 1 (Fig. 62) from the light mounting frame. The ceiling light is held with metal retaining spring and hooks in the back of the mounting frame bracket. To remove ceiling light you should insert a flat screwdriver into the chase on the right side of the light (from the side of the front

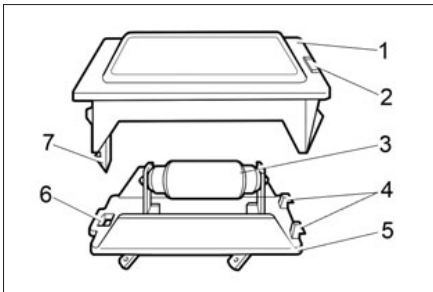

Fig. 64a. Luggage compartment light

passenger seat) and carefully turn out the light to yourself. Depress the contacts and pull out the bulb. After replacing the bulb set the ceiling light hooks into the socket of the unit on the left side and push the right side of the light to fix it.

Interior illumination unit

To remove the bulb in the Interior illumination unit you should remove lens 1 (Fig. 63) with the help of a flat screwdriver, inserting it into special slots. Individual lighting bulbs are removed after turning them for 45° clockwise or counter-clockwise. The unit is held in the mounting bracket by means of latches 2.

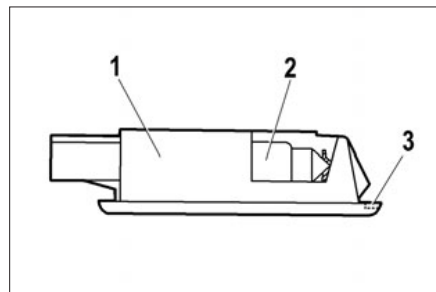

Fig. 64b. Luggage compartment light, «liftback» vehicle

Luggage compartment light

To remove the bulb 3 (Fig. 64a) in the luggage compartment light, remove the light from the body mounting bracket, for this insert the screwdriver into slot 2 from the right side of the light and carefully turn it towards yourself. Then press latch 7, withdraw it out of hole 6 and remove headlight glass 1. The bulb is held with spring contacts. After replacing the bulb, install headlight glass 1 in such way, that the mounting «lugs» 4 of the light case 5 run into its slots.

To replace light bulb 2 (Fig. 64b) in the luggage compartment light 1 in «liftback» vehicle you should remove the light from the vehicle.

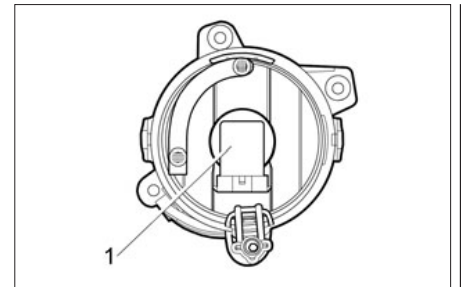

Fig. 65. Fog light

The roof light is held in the socket with retaining spring. Insert a flat screwdriver into the chase 3 on the right side of the roof light and carefully depress the roof light down and pull the bulb 2.

After replacing the bulb the assembly and installation of the luggage compartment light should be carried out in reverse order.

Fog light

Dismount the inoperative bulb in the fog light (Fig. 65). Turn the bulb base 1 counter-clockwise and remove out of the reflector, disconnect the terminal block from the lamp. The new bulb installation is carried out in reverse order. To prevent leav-

ing traces on the bulb, install the halogen bulb using the gloves. This type of operations is recommended at the SSNE certified by the manufacturer, using the lift.

To free access to the fog light under the front wheel arch, you must first dismount the wheel and partially loosen the fixture of the front wing flap by removing six screws. Turn back the flap, dismount the inoperable bulb from the fog light.

In the design variant there are special hatches for access to the fog lights on the front wing flaps. If such hatch is available the bulb replacement procedure will be as follows:

- to reach access to the hatch cover, turn the front wheel inside the arch to the maximum;
- remove the hatch cover in the front wing flap;
- after the cover removal, the access to the bulb is reached through the hatch in the front wheel flap;
- turn the bulb counter-clockwise and pull it out;
- disconnect the terminal block and replace the bulb.

Install the new lamp in reverse order. To facilitate the operation on the bulb replacement, it is recommended to remove the front wheel preliminary.

BODY

The body is the basic and the most costly vehicle component. It is made of advanced materials and is protected against corrosion by high-quality protective agents. The foundation of the corrosion protection lifetime is laid down by the manufacturer, however, paint and other protective and decorative coatings are subject to normal wear and ageing. The effectiveness of corrosion protection and its lifetime depend on climatic conditions, environment ecological state, conditions of use, storage, proper care and timeliness of preventive measures.

Avoid applying excessive forces to open or close the doors, the trunk lids and the bonnet that would lead to damage and/or scuffs of the doors and the body, for which the manufacturer is not responsible.

To prevent the appearance of scratches on the body paint coating, as well as on the external optical surfaces of the vehicle light devices, do not remove dust and dirt with dry cleaning material. For the sake of the vehicle preservation, prior to the time the dirty dries, it is necessary to wash

it with small pressure water spray using soft sponge and applying car shampoos that create protective films against the environment impact.

ATTENTION!

Do not wash the vehicle using soda and caustic solutions, as well as sewage and other agents not intended for washing.

Before washing the vehicle, clean the doors and sills drain holes.

ATTENTION!

Due to a large choice of services on the market of washing machines with brush assemblies of different design, the vehicle wash with the use of brush washing machines can lead to the loss of paint coating gloss and reduction of its protective properties. Therefore, before washing your vehicle ask preliminary the washer operator of its design, technical condition of brushes and the level of its impact on your vehicle paint coating.

In summer wash your vehicle outdoors in the shade. If this is not pos-

sible, wipe the washed surfaces dry immediately, for when water droplets dry in the sun, the spots are created on the painted surface. In winter, after washing the vehicle in a warm room, before driving out clean the body and door seals dry, as, during the remaining water droplets freezing, the cracks on the paint coating may be formed and the seals may freeze to the body.

ATTENTION!

Do not wash the vehicle with the ignition on.

When washing the vehicle avoid the direct spray of water ingress on electrical products, electronic devices, sensors and detachable joints in the engine compartment. Watch after condition of the protecting covers for the detachable joints in electronic units and sensors. In case of ingress of moisture onto the detachable joints, blow them with compressed air and treat them with water-repellent auto-inhibitor to protect the contacts against oxidation.

During washing the vehicle thoroughly wash the hemmings of the doors, the bonnet, the trunk lid, the welds and the joints of the engine

compartment, the luggage compartment and the door openings, as the dirt accumulated in the specified areas will cause damage of the protective and decorative coatings and metal corrosion.

ATTENTION!

When the signs of corrosion (including welded joints and seams), as well as damage of the paint coating (chips, scratches, abrasions) and other protective coatings (chips and putty and undercoat abrasion) appear, you should address at the manufacturer authorized SSNE to take actions to prevent further corrosion propagation, to restore and repair the paint and protective coatings.

Well-timed actions taken to prevent propagation of corrosion on the body and other parts of the vehicle will extend its service life and save its market condition for a long time. In case of your failure to take timely measures to prevent corrosion processes on the vehicle body, the manufacturer bears no responsibility for your vehicle body further condition.

To improve corrosion resistance of the body, the enclosed box-shaped cavities of sills, side members, cross members and other elements of the body bottom are covered with a special anti-rust compound. When operating the vehicle it is necessary to carry out anti-corrosion treatment of the body at the manufacturer certified SSNEs during the first year of operation and periodically once a year according to his developed technology.

ATTENTION!

After anti-corrosion treatment of the body by the anti-rust compound at the SSNE it is necessary to check the exhaust system (catalytic converter, main and auxiliary silencer) for lack of anti-rust composition on these parts to prevent probable fire hazard.

During vehicle operation the coating on the body bottom, as well as the paint on the lower parts of the front and rear wings are exposed to abrasive wear due to impact of gravel, sand and salt. As a result of this impact the putty and undercoat get abraded and the bare metal corroded. Therefore, watch after the state

of these coatings regularly and in a timely manner restore the damaged areas.

For preservation of gloss of the vehicle painted surfaces (especially the vehicles that are stored outdoors) polish them regularly with the use of polishing pastes. These pastes close cracks and voids appearing in the paint coating during the operation and prevent corrosion under the paint layer.

To maintain the body glossy for a long time, do not leave the vehicle in the sun for long, and avoid the body surface contacts with acids, solutions of soda, brake fluid and gasoline.

To prevent the spots of gasoline from occurring on the paint coating under the fuel tank hatch, wipe the surface with clean cloth before and after filling.

Due to unfavourable environmental conditions in some areas, there are cases of aggressive effects of the individual components of the environment on protective and decorative coatings of the vehicle. These impacts occur in the form of red pimple, local change in colour of exterior paint coating, local damage of the body enamel coating.

The reason for red pimple occurrence is deposition of the air-borne metallic dust fine particles on the body horizontal surface, that stick to the body with corrosion products during humidification with dew. The red pimple may be removed with 5% solution of oxalic acid and detergent followed by ample washing with clean water.

Local changes in colour (spots) of the outer paint coating and local damage of the enamel coating of the body are the result of acidic industrial emissions impact after their combining with air moisture. Such impacts, depending on the exposure severity level are eliminated through body polishing or repainting.

Wipe plastic parts with a damp cloth. Using of gasoline or solvents is prohibited, as plastic parts lose their gloss.

ATTENTION!

When washing and cleaning the passenger compartment, avoid ingress of water and small items (such as crumbs, dog hair, etc.) in the electrical equipment.

EXTERIOR LIGHT AND EXTERIOR LIGHT ALARM INSTRUMENTS

Vehicles are equipped with lights and headlight glasses made of plastic.

To prevent damaging the plastic headlight glasses during washing, do not use corrosive and abrasive cleaners or chemical dilutants.

To avoid blushing and occurrence of scratches never wash rub dry dirt from the outer surface of the headlight glasses, preliminary water the surface of the lens properly, for cleaning use a soft cloth or a sponge, do not use sharp objects to clean the lenses of icing.

Warning

Premature blushing of headlight unit glasses lead to poor illumination of the roadway, to distortion of the light-and-shade borderline and dazzling of the oncoming vehicle drivers.

Under very moist hot or cold air conditions, for example, in heavy rain, when washing the vehicle, the condensate water may occur on the inner surfaces of lighting and light-signal instrument glasses for a short time duration. No special measures

are required for condensate water disappearance. Condensate water disappearance should occur during the vehicle operation, and to speed up this process, you should switch on the appropriate light devices.

VEHICLE STORAGE

During the vehicle operation pay much attention to its storage conditions. The following meet the vehicle storage optimum conditions:

- the shed with temperature and humidity corresponding to environmental parameters, there is constant motion of air and no solar radiation and precipitation direct exposure;
- the heated room (individual garage) with a temperature minimum 5°C and relative humidity of 50–70%, equipped with supply and exhaust ventilation.

In case the heated room (individual garage) is equipped with ineffective supply and exhaust ventilation, and the vehicle after operation in winter or after washing is placed in storage without prior drying, the destructive effect on its protective and decorative coatings increases by many times.

When storing the vehicle in winter under the shed or in the unheated room remove the storage battery and store it separately; drain water from the window washer reservoir.

1. Wash your vehicle and dry its body. Apply the preservative compound on the body.
2. Fully charge the storage battery.
3. Disconnect the negative lead from the storage battery.

The vehicle service during storage (once in two months) includes the following:

- start the vehicle engine for 1-2 minutes, taking measures for extraction of exhaust gases;
- check the operability of systems and alarm indicators;
- shut-off the engine.

VEHICLE TECHNICAL SPECIFICATION

Table 8

Main parameters and characteristics of the vehicle 2190 «sedan»

Variant of design	Norm		Luxe	
Engine model	11186	21126	21126	21126
Powertrain type	mechanical gearbox	mechanical gearbox	mechanical gearbox	automatic gearbox
Number of doors	4			
Number of seats, pers.	5 (first row – 2, second row – 3)			
Number of seats with fully folded rear seats, pers.	2			
Overall dimensions, mm	Fig. 66			
Layout scheme	with transverse engine mounting and front-wheel drive			
Engine type	four-stroke, spark-plug ignition			
Engine fuel feeding system	electronically controlled fuel injection			
Engine ignition system	electronic ignition with static distribution			
Engine displacement, cm ³	1596			
Number of cylinders	4			
Engine cylinders arrangement	in-line			
Number of valves in the engine cylinders	8	16		
Nominal compression ratio in the engine cylinders	10,3	11,0		
Maximum engine power, kW (min ⁻¹), according to (ISO 1585)	64,0 (5100)	72,0 (5600)		
Maximum engine torque, N·m (min ⁻¹)	140,0 (3800)	145,0 (4000)		

Extension of table 8

Variant of design	Norm		Luxe	
	11186	21126	21126	21126
Engine model	11186	21126	21126	21126
Fuel	Premium Euro-95			
Kerb weight (with driver 75 kg), kg:				
– min weight, kg	1080			
– max weight, kg	1140			
Gross (max allowed) weight, kg	1560			
Road clearance at full load under the engine case, mm	not less than 160			
Road clearance at full load under the gear case, mm	not less than			
	165			145
Max speed*, km/h	167	181	182	175
Acceleration from rest up to 100 km/h*, sec	12,2	11,2	11,2	13,1
Gross weight of trailer under tow**:				
– not equipped with brakes, kg	450			450
– equipped with brakes, kg	900			750

* Measured by a special technique.

** Subject to the vehicle equipment with towing hitch according to ECE UN Regulations № 55-01.

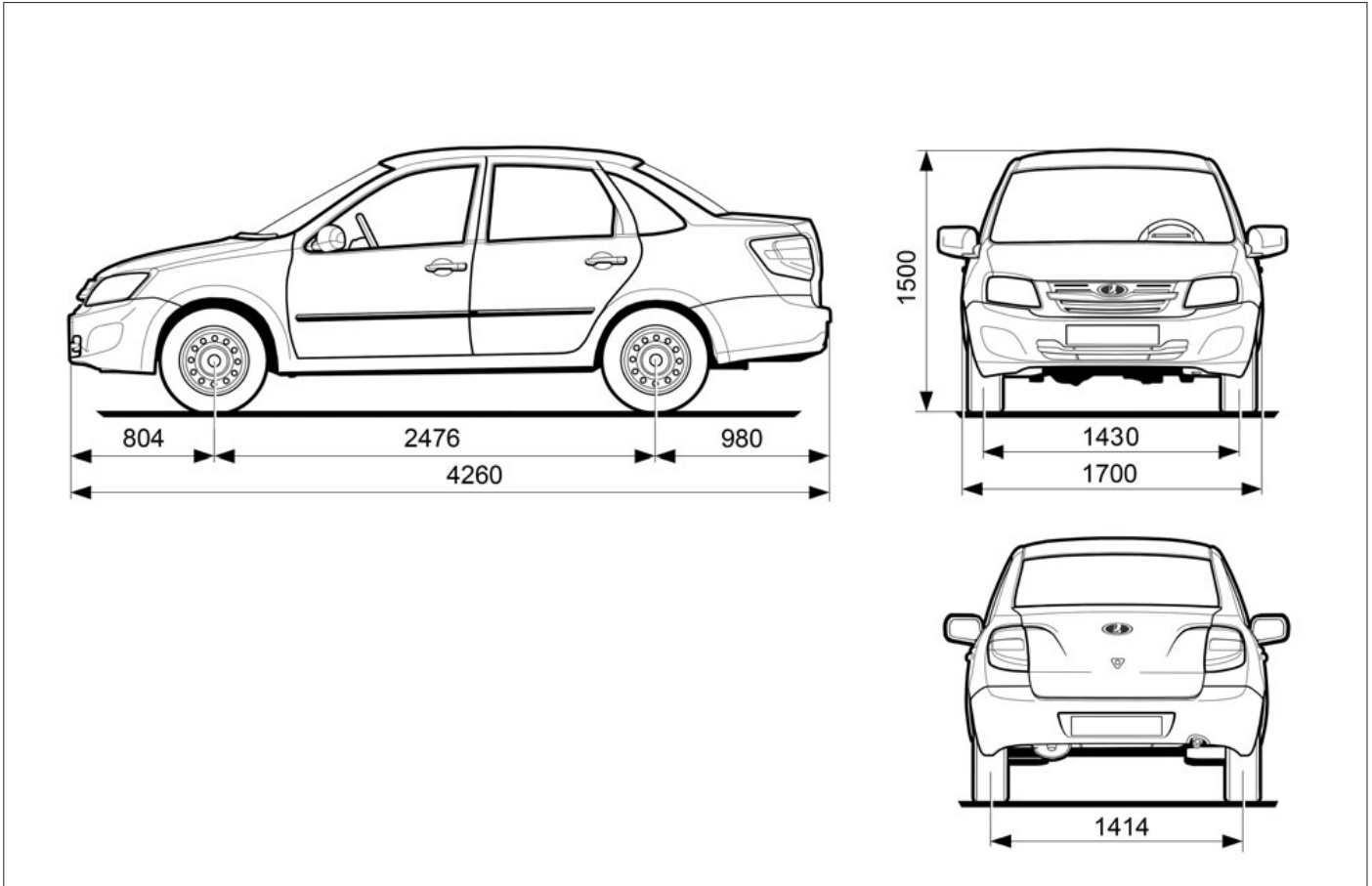

Fig. 66. Overall (reference) dimensions of the vehicle 2190 («sedan»)

Table 8a

Main parameters and characteristics of the vehicle 2191 «liftback»

Variant of design	Norm		
	11186	21126	21126
Engine model	11186	21126	21126
Powertrain type	mechanical gearbox	mechanical gearbox	automatic gearbox
Number of doors	5		
Number of seats, pers.	5 (first row – 2, second row – 3)		
Number of seats with fully folded rear seats, pers.	2		
Overall dimensions, mm	Fig. 67		
Layout scheme	with transverse engine mounting and front-wheel drive		
Engine type	four-stroke, spark-plug ignition		
Engine fuel feeding system	electronically controlled fuel injection		
Engine ignition system	electronic ignition with static distribution		
Engine displacement, cm ³	1596		
Number of cylinders	4		
Engine cylinder arrangement	in-line		
Number of valves in the engine cylinders	8	16	
Nominal compression ratio in the engine cylinders	10,3	11,0	
Maximum engine power, kW (min ⁻¹), according to (ISO 1585)	64,0 (5100)	72,0 (5600)	
Maximum engine torque, N·m (min ⁻¹)	140,0 (3800)	145,0 (4000)	
Fuel	Premium Euro-95		
Kerb weight (with driver 75 kg), kg:			
– min weight, kg	1080		
– max weight, kg	1140		

Extension of table 8

Variant of design	Norm		
Engine model	11186	21126	21126
Gross (max allowed) weight, kg	1560		
Road clearance at full load under the engine case, mm	not less than 160		
Road clearance at full load under the gear case, mm	not less than		
	165		145
Max speed*, km/h	167	181	175
Acceleration from rest up to 100 km/h*, sec	12,4	11,5	13,5
Gross weight of trailer under tow**:			
– not equipped with brakes, kg	450		450
– equipped with brakes, kg	900		750

* Measured by a special technique.

** Subject to the vehicle equipment with towing hitch according to ECE UN Regulations № 55-01.

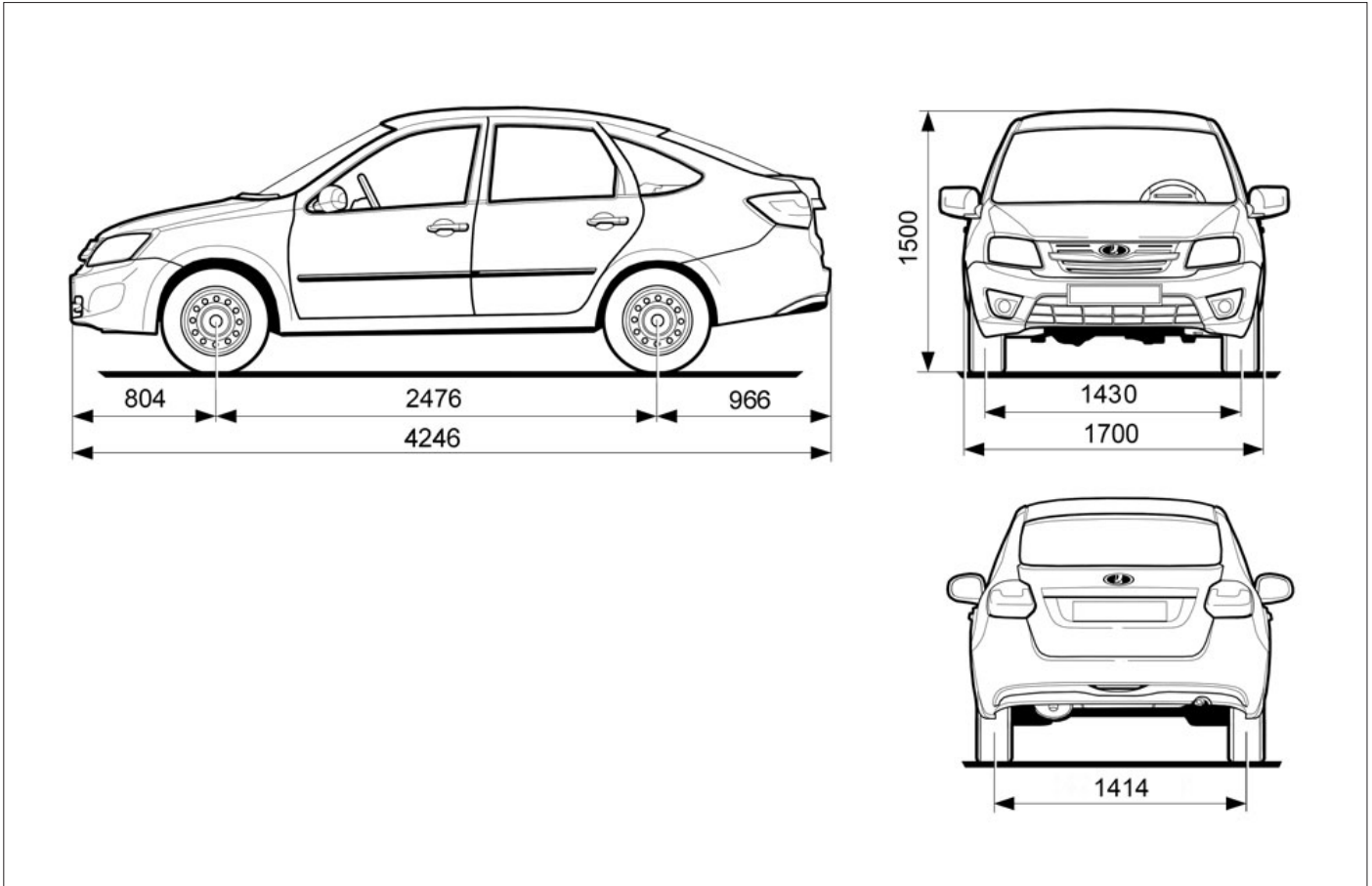

Fig. 67. Overall (reference) dimensions of the vehicle 2191 «liftback»

Table 6

Filling volumes, l

Fuel tank	50
Engine lubrication system with MGB:	
– dry engine fuelling	3.2
– oil and filter replacement	2.9
Engine lubrication system with AGB:	
– dry engine fuelling	4.4
– oil and filter replacement	4.1
Engine cooling and interior heating system*	6.3...6.5
Mechanical gearbox with traction operated actuator	3.1
Mechanical gearbox with cable-operated actuator	2.2
Automatic gearbox	up to mark MAX**
Brake hydraulic drive system	0.45
Windshield washer reservoir	3.0

* Use of cooling fluid mixtures of different brands.

** Automatic gearbox is integrated with the piping system and the heat exchanger. Fuelling of this system with working fluid is possible only at the certified SSNE.

Table 7

Climate control system coolant (for version with control system coolant)

Coolant type	System filling capacity
1234 YF	390 ± 20 g

PASSPORT DETAILS

A plastic identification (factory) plate is installed on the vehicle (Fig. 68). The numbers on plastic plate shall be read as follows:

- 1 – vehicle designation;
- 2 – engine designation;
- 3 – spare parts number;

(Number for spare parts corresponds to progressive sequence number.)

When ordering spare parts it is necessary to use the information containing on identification (factory) plate.)

- 4 – manufacturer;
- 5 – EEC type-approving certificate number;
- 6 – identification number (VIN);
(Identification number is decoded as follows: first three letters according to international standards are the code of manufacturer-plant; six following numbers or Latin letters – car model; the following number or Latin letter – represents the model year; last seven numbers – chassis number, for passenger car it corresponds

to body number. According to technical requirements «On wheeled transport safety» model year is defined as a conventional year indicated by the manufacturer. In JSC AVTOVAZ the model year starts from July, 1 of calendar year. So, in the period from January, 1 till June, 30 the model year corresponds to actual year of manufacture, and beginning from July, 1 till December, 31 corresponds to the following year.

VIN is also stamped on the right-hand telescopic strut.)

- 7 – technically permissible max. gross weight of vehicle;
- 8 – technically permissible max. gross weight of truck and trailer;
- 9 – technically permissible maximum permissible load on front axle;
- 10 – technically permissible maximum permissible load on rear axle.

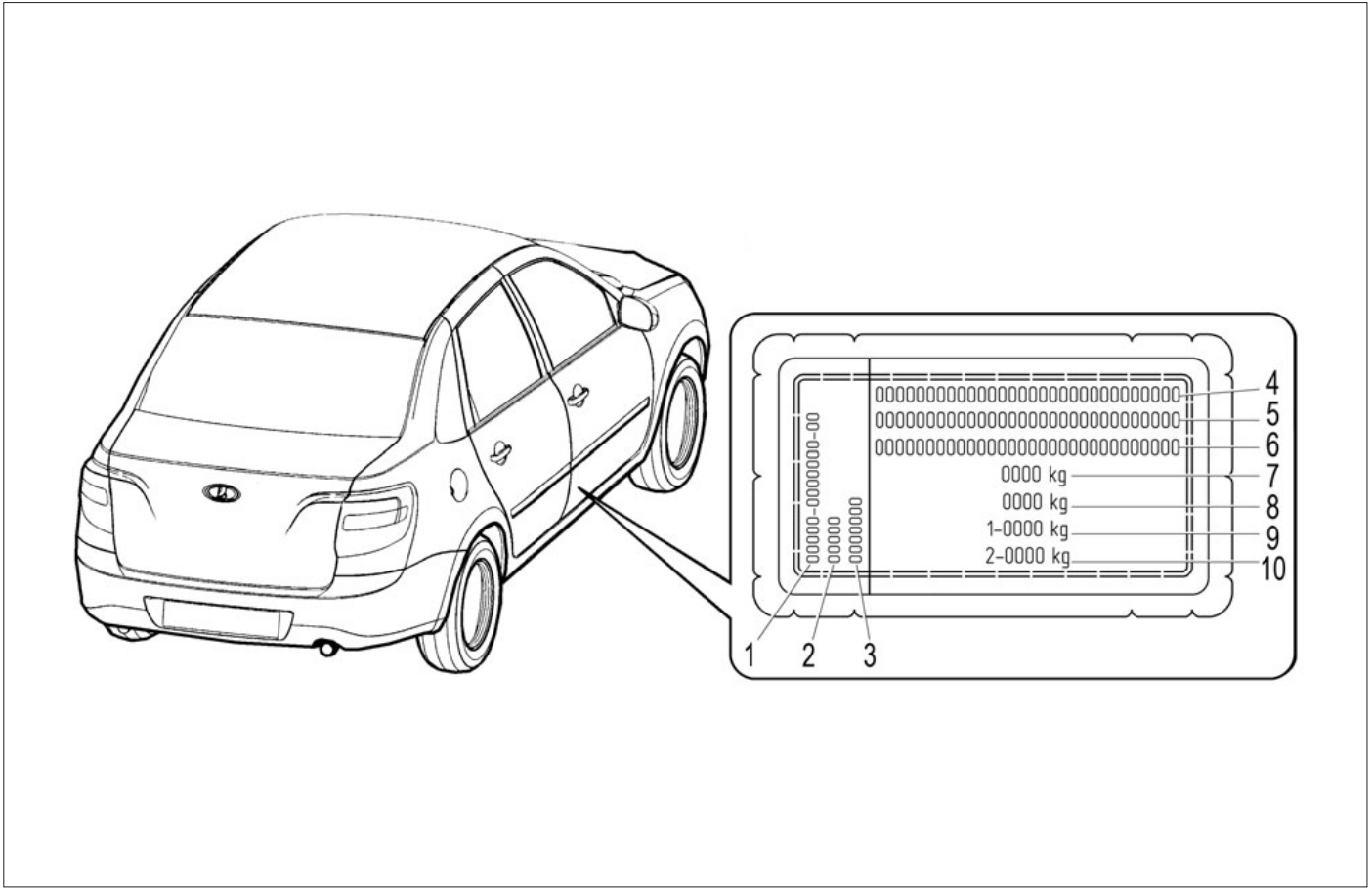

Fig. 68. Passport details. Installation site of name plate – center pillar, RH

APPENDICES

Appendix 1

FUELS AND LUBRICATIONS APPROVED AND RECOMMENDED FOR USE OF LADA GRANTA AND ITS VERSIONS

MOTOR GASOLINES

Table 1

Recommended gasoline brand
Not less 95 octane gasoline

Notes:

1. To ensure engine starting and vehicle operating at low negative ambient temperatures you must use gasolines of corresponding volatility classes depending on the climatic region. Requirements for the classes of volatility and seasonal use of gasolines for different regions of the Russian Federation are set out in the relevant standards on fuel for internal combustion engines.

2. Do not use gasoline with organometallic fuel dopes based on lead, iron, manganese and other metals.

3. It is allowed to use additives that protect the fuel supply parts and the engine against corrosion, deposits and soot deposits. These additives must be a part of commercial gasoline by the manufacturer of the gasoline.

It is not recommended for owners of vehicles to add secondary additives to gasoline.

Table 2

ENGINE OIL

Based on the table below, determine the level of quality and oil viscosity grade, prescribed for your vehicle in accordance with the existing operating temperature range.

If necessary – change the oil. For this purpose refer to the authorized service center.

Filling point	Description		
Engine lubrication system	Engine oil SAE viscosity grades and operating temperature range		
	Minimum temperature of cooling medium under the vehicle operation °C	SAE J 300 viscosity grade	Maximum environment temperature under the vehicle operation, °C
	-40	0W-30	25
	-40	0W-40	30
	-30	5W-30	25
	-30	5W-40	35
	-25	10W-30	25
	-25	10W-40	35
	-20	15W-40	45
	-15	20W-40	45
	-15	20W-50	up 45
The quality level of operational properties: API SL/API SM/API SN CTO AAI 003 B5/CTO AAI 003 B6			

Use only recommended operating and lubricating fluids. For information on the recommended operating and lubricating fluids, refer to the authorized service center.

LAMPS USED IN THE VEHICLE

Installation site	Type designation	
	international	Russian
Headlight*: – main beam bulb – dipped beam bulb – direction indicator bulb – daytime running light and tail light bulb	H4 H4 PY21W W21/5W	AKG 12-60+55 AKG 12-60+55 A12-21-4 –
Front fog light bulb*	H11	–
Rear light*: – stop signal and taillight bulb – backing light bulb – fog light bulb – direction indicator bulb	P21/5W P21W P21W PY21W	A12-21+5-2 A12-21-3 A12-21-3 A12-21-4
Side turn indicator bulb* Number-plate light bulb* Interior general illumination light bulb Individual illumination lamps for driver and front passenger seats Luggage compartment light	W5W C5W C10W T4W C5W	A12-5-2 AC12-5-1 AC12-10-1 A12-4-1 AC12-5-1

ATTENTION!

* The vehicle headlights and light signalling devices are homologated (have the sign «E») for compliance of light, colour characteristics and light sources (bulbs and lights) with international safety requirements. For all lighting devices the use of other light sources is not permitted, as it may cause a malfunction of these devices and violation of safety requirements.

IGNITION PLUGS*

Engine type	Spark plug type
8-valve engine	A17DVRM JSC «Robert Bosch Saratov» LR15YC-1 BRISK WR7DCX Bosch
16-valve engine	AU17DVRM JSC «Robert Bosch Saratov» DR15YC-1 BRISK FR7DCU Bosch

*Spark plug gap should be in the range of 1...1.15 mm.

USER'S MANUAL FOR RADIO AND AUDIO FILE PLAYER
(optional design)

This user manual is applied for radio and sound file player 2190-7900010-20 (hereinafter referred to as radio) and is meant for study of its structure, operating principles, technical features, usage guidelines and service of the product.

WARNING! The warranty is void in case of damages occurred due to negligent handling the product and unskilled maintenance as well as in case of outside damages.

1. Description of radio

1.1 Appearance

1.1.1 Fig.1 shows appearance of outside panel of the radio and sound file player 2190-7900010-20 is presented.

1.2 Description of control panel

1.2.1 Control panel with relevant figures on Fig. 2 is described in Table 1.



Fig. 1. Appearance and shape of outside panel of radio (optional design)

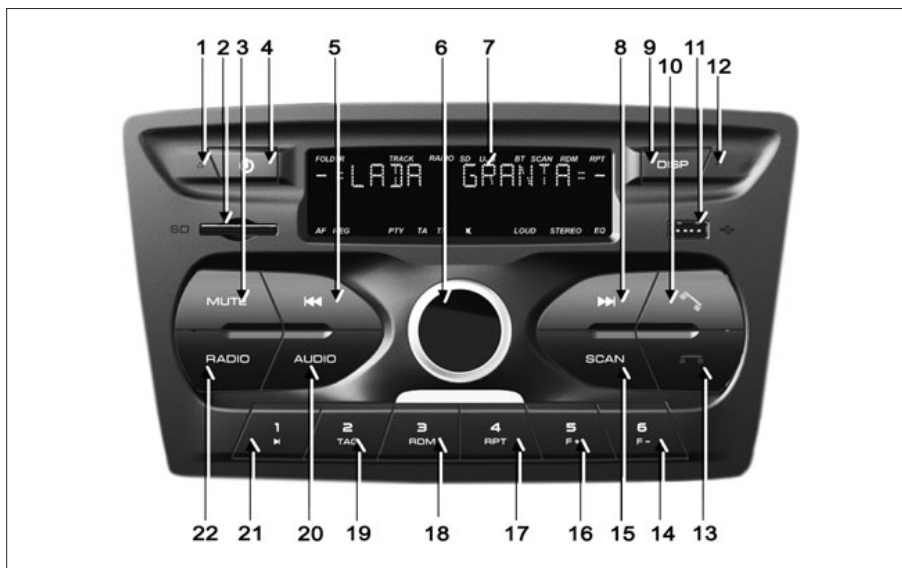

Fig. 2. Control panel of radio (optional design)

1.2.2 To reset radio settings to factory settings in conformity with Table 2, it is necessary to use function Reset in system setting menu (see par. 6.3).

Table 1





Nº	Name of control device	Symbol of control device
1	Microphone	
2	SD memory card slot	
3	Sound off button	MUTE
4	Radio On/Off switch	
5	Multifunction button	
6	Rotary encoder switch, multifunction	
7	Display	
8	Multifunction button	
9	Multifunction button	DISP
10	Phone switch, accept incoming call	
11	USB Flash drive slot	
12	Reset button. Recover radio in case of deadlock	
13	Phone switch, return to previous mode, shut off incoming call	
14	Multifunction button	6 F-
15	Multifunction button	SCAN
16	Multifunction button	5 F+
17	Multifunction button	4 RPT
18	Multifunction button	3RDM
19	Multifunction button	2 TAG
20	Multifunction button	AUDIO
21	Multifunction button	1 ►
22	Multifunction button	RADIO

Table 2

Parameter	Setting
Clock time	After reset it will be automatically synchronized by CT
CT	On
AM	On
BT	On
AF	Off
Beep	On
BASS	0
TRE	0
BAL	0
FAD	0
EQ	Off
RDS RTY	No RTY
RTY REG	REG off
Tone compensation	Off
Volume	10
Memory cell content	Constant
Player stop position	Not saved
Information on phone connected	Saved
Saved phone numbers	Not saved

1.3 Description of display

Appearance of display is presented on Fig. 3:

- 1** – folder number indicator;
- 2** – track played indicator;
- 3** – playing window;
- 4** – «radio» mode indicator;
- 5** – playing SD-card indicator;
- 6** – playing USB-drive indicator;
- 7** – connection to radio via Bluetooth indicator;
- 8** – scanning radio stations indicator;
- 9** – random track playing indicator;
- 10** – repeat track indicator;
- 11** – equalizer indicator;
- 12** – stereo mode indicator;
- 13** – tone compensation indicator;
- 14** – silent mode indicator;
- 15** – traffic information acceptance indicator;

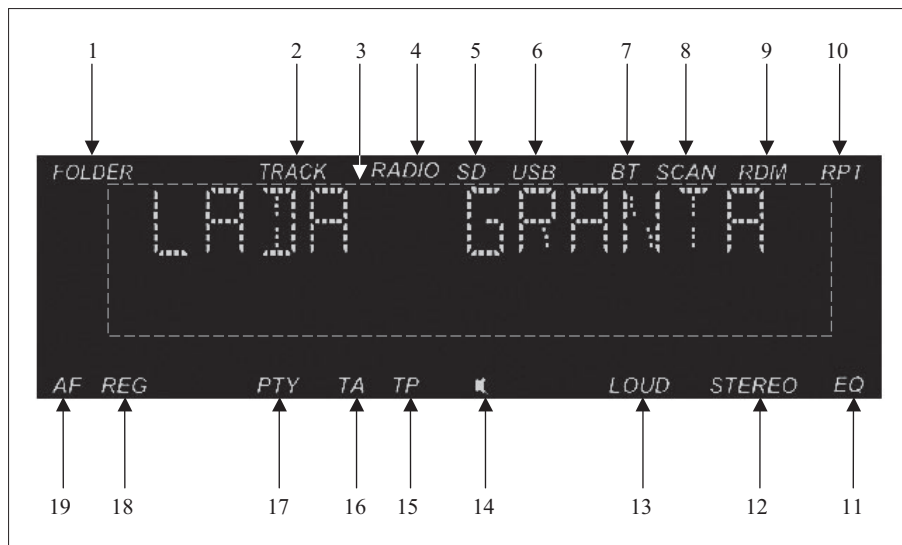

Fig. 3. Display of radio

16 – traffic information transmission indicator;

17 – search for radio stations by program type indicator;

18 – accepting local radio stations indicator;

19 – search for alternative band indicator.

1.4 Inserting and removing memory cards

1.4.1 To insert a memory card, put it with beveled side forward and to the right into SD-card slot (pos. 2) (here and after numbers of buttons are mentioned according to Fig. 1) until it fits.

1.4.2 To remove a memory card, push it. The card will come outside.

1.5 Inserting and removing USB flash drive

1.5.1 To insert USB flash drive, put it into USB Flash drive slot (Fig. 2, pos. 11).

1.5.2 To remove USB flash drive, it is necessary to quit sound file playing mode and remove it from USB Flash drive slot with no force applied.

2. Radio control

2.1 General conditions

2.1.1 It is only allowed to control the radio only when you are completely sure that it will not endanger safety of traffic.

ATTENTION!

Watch the road carefully! The driver is fully responsible for traffic safety. Use the device ensuring control over the vehicle in any situation.

2.1.2 To prevent an accident when driving a vehicle:

- do not tune radio;
- do not make volume very loud as it may prevent perception of alarm from other vehicles.

2.1.3 Try not to park a vehicle on a parking under direct sunlight that may cause high temperature rise inside the passenger compartment. Before starting playing, let temperature inside fall down.

2.1.4 The radio is designed to operate at ambient temperature from minus 40°C to plus 70°C. Before use the temperature inside shall come into tolerable thresholds.

2.1.5 The radio is designed to be connected to on-board system of a vehicle with 12V with minus on the case. Do not connect radio in vehicles with other voltage values.

2.1.6 USB Flash drive slot is designed to connect USB Flash card, USB Flash player with memory at least 1024 Mb, USB HDD with FAT 32 file system and Mobile phone (only in charge mode).

2.2 Switching radio on/off

2.2.1 To switch radio on and off, push the button  shortly (pos. 4). Having been switched on, the radio will turn into mode before switching off.

2.2.2 In case if the radio does not react to control buttons, push (with fine flat pin) and hold **Reset** (Fig. 2 pos. 12) button within 2-3 seconds. Having been switched on with the button , the radio automatically turns into radio playing mode.

ATTENTION!

The radio maintains user settings (radio station bands, sound settings, user settings) not more than 10 days after battery terminals were disconnected.

2.3 Sound settings

2.3.1 Volume setting is made rotating encoder rotary switch (Fig. 2 pos. 6) to the right or to the left.

2.3.2 Short pushing encoder rotary switch allows enter setting sound mode. A parameter to be

tuned is selected rotating encoder rotary switch.

2.3.3 To shut off sound, push **MUTE** button (Fig. 2 pos. 3). To switch on sound, push the button again or rotate encoder rotary switch.

2.4 Time display

2.4.1 If to push **DISP** button (Fig. 2 pos. 9) with the radio switched off, display will show the current time within 15 seconds but only with ignition on.

2.5 Welcome display with radio on

2.5.1 When the radio is switched on, the screen will show a welcome message «LADA Granta».

3. Radio mode

3.1 Radio activation

3.1.1 To activate the radio use one of the ways listed below:

- by pressing **RADIO** button (Fig. 2, pos. 22);
- with radio switched-on by ejection all external drives (USB sticks, SD cards).

Note. There will be no switching to Radio mode after removal of external drives, if Radio is in «reception of telephone call» or «playback music from telephone» modes.

3.1.2 In this mode upper line of the display will contain radio station's frequency, range and number of cell where current station is stored. Lower line will contain time, radio text, radio station name (received through RDS) and etc.

3.1.3 Selection of information to be displayed is done by pressing **DISP** button (Fig. 2, pos.9).

3.1.4 Radio is designed to receive signals within FM/VHF and AM ranges. For this there are 6 levels of memory provided:

- 1 level for AM range (AM1);

- 1 level for VHF range (VHF);
- 1 level for FMAS range (combined VHF-FM range);
- 3 levels for FM range (FM1-FM3).

3.1.5 Each level has 6 memory cells. Memory can store up to 36 radio stations.

Note. Some buttons may have default frequency, e.g. if least than 6 stations were detected during automatic search.

3.2 Manual search for radio stations

3.2.1 When in Radio mode press and hold **◀◀** button (Fig. 2, pos. 5) or **▶▶** (Fig. 2, pos. 8). Radio will switch to manual search for radio stations. Search is conducted by turning encoder knob (clockwise – upstream the range, counterclockwise – downstream the range).

Note. This mode is unavailable within FMAS range.

3.3 Automatic search for radio stations

3.3.1 There are three modes of automatic search for radio stations:

– 1st mode. Automatic search for next/previous station. To do this press one of the buttons **◀◀** or **▶▶** (Fig. 2, pos. 5 or 8);

– 2nd mode. Automatic search for and saving 6 radio stations with the most steady reception within FMAS range (combined VHF-FM range). At the same time new range FMAS will appear on the list of ranges. To do this press and hold **SCAN** button (Fig. 2 pos. 15) until message «AUTOSEARCH» appears on the display.

– 3rd mode. Automatic search followed by storing radio stations received within set range into radio's memory. In this mode search is performed via short pressing of **SCAN** button (Fig. 2, pos.15).

Note. When selecting any of FM1-FM3 ranges and starting automatic search, radio will store not more than 18 radio stations in its memory (6 radio stations within each range). Upon end of search, radio will start receiving the 1st station found within FM1 range.

3.4 Storing radio stations

3.4.1 In order to store selected radio station into radio's memory, press and hold on of the buttons **14**,

16, 17, 18, 19, 21. Until the number of cell with stored radio station appears on the display and audio signal heard (if sound confirmation for button) confirming that radio station has been successfully stored.

Note. Station storing by user is not available for FMAS range.

3.5 Listening to previously found radio stations

3.5.1 Selection of radio station stored within memory is performed by brief pressing of **14, 16, 17, 18, 19, 21** (Fig. 2) buttons.

3.5.2 Upon brief pressing of **RADIO** button (pos. 22) range of received waves will be switched as follows VHF – FM1 – FM2 – FM3 – FMAS (this range will be available after searching within combined VHF-FM) – AM1, by loop.

Note. If CB range is switched off in user's settings, then modes will be switched in the following sequence VHF – FM1 – FM2 – FM3 – FMAS (this Range is available after search within combined VHF-FM range only).

3.6 RDS function

3.6.1 RDS (Radio Data System) is a multi-purposed standard designed for transferring information messages via channels of transferring modulation of broadcast within VHF range.

3.6.2 Radio has RDS functions provided in Table 3.

4. Audio mode

4.1 Playing back audio files

4.1.1. Switching to the audio files listening mode can be carried out in the following ways:

- by connecting of SD-card;
- by connecting of USB-drive;
- by pressing **AUDIO** (Fig. 2, pos. 20).

Note. Switching to AUDIO mode will not happen if the receiver is in CALL mode.

4.1.2 Correct connection is described in Appendix B.

4.1.3 In this mode in the upper line (Fig. 4, pos. 3) the number of folder or track title and current track time is indicated. In the lower line – the track name → file name → folder name →

artist name (selection is made by short pressing of **DISP** button (pos. 9). If the information is larger than 16 symbols, the line will be cycled.

ATTENTION!

The radio plays back audio files in MP3 и WMA formats.

4.2 Playback start/stop

4.2.1 To start the audio files play back you should:

- install SD/USB with audio files;
- press button **1 «▶|»** (Fig. 2, pos. 21).

Note: Playback is automatically stops after pressing **MUTE** button (Fig. 2, pos. 3) or when incoming phone call is received and automatically continues after pressing or turning encoder handle (Fig. 2, pos. 6), or after end of phone call.

4.3 Displaying of additional information (if any)

4.3.1 Press button **2 TAG** (Fig. 2, pos. 19) – the additional information about the current file will be displayed (singer name, album title or song title) with MP3 extension.

4.3.2 To stop displaying this information press again **2 TAG** (Fig. 2, pos. 19).

Table 3

RDS function	Description
AF	Activation of alternative frequency (AF) makes the receiver to search the best receiving of the chosen station. During the search of the best receiving, the broadcasting may be temporarily interrupted. If the receiving quality is poor and it is not possible to find alternative frequency, choose other station
PS	Informs the title of programs transmitted by station
TP	Contains information about traffic organization on the chosen road
TA	Contains information about road traffic
CT	Continuously updated information on date and current local time that can be used for displaying or automatic time setting
PTY	Automatic search of programs of specific type

4.4 Controlling playback modes

4.4.1 If USB and SD are temporarily installed there are both icons active (Fig. 4, pos. 5 and 6), the icon of playing medium is blinking. Playback source choosing by **AUDIO** button. (Fig. 2, pos. 20).

4.4.2 Switching repeated playback on/off is made by short pressing of **4 RPT** button (pos. 17). RPT indicator is on (Fig. 3, pos. 10), and TRACK symbol (Fig. 4, pos. 2) will be blinking.

4.4.3. Switching On and Off repeated playback mode is made by pressing and holding 4 RPT button

(pos. 17) up to appearing the message «FOLDER REPEAT». The symbol RPT (Fig. 4, pos. 10) will be active and indicator FOLDER (Fig. 4, pos. 1) – blinking.

4.4.4. Switching On and Off the random playback mode is made by short pressing of **3 RDM** (pos. 18). The symbol RDM (Fig. 4, pos. 9) is active, and in the lower line of display there is short message «RDM FOLDER» present. At random playback the indicator RDM (Fig. 4, pos. 9) is present, and sign FOLDER (Fig. 4, pos. 1) is blinking.

4.4.5. Switching On and Off random playback mode of whole medium is made by pressing and holding **3 RDM** (pos. 18). Sign RDM is active (Fig. 4, pos. 9), and in the lower line there is a message «RDM ALL».

4.4.6. Buttons **6 F-** or **5 F+** (pos. 14 or 16) are used for fast switching for previous or following folder playback. To chose necessary folder (with title indication) turn the encoder handle after short pressing of **SCAN** button. To chose necessary track (with title indication) turn the encoder handle after pressing and holding of **SCAN** button.

4.5 MUTE mode



4.5.1. When pressing the button **MUTE** (Fig. 2, pos. 3) there is corresponding sign in the lower part of screen (Fig. 3, pos. 14).

4.5.2. To switch the sound on press the button **MUTE** again (Fig. 2, pos. 3) or increase the volume by encoder.

5. Bluetooth® mode

5.1 Switching On and Off Bluetooth® function

5.1.1 There are several ways to switch **Bluetooth®** on and off:

- menu «Tel connection» in system setup of the radio system;
- by long pressing  button (Fig. 2, pos. 10) - switching on **Bluetooth®**;
- long pressing  button (Fig. 2, pos. 13) - switching off **Bluetooth®**.

5.2 Connection of telephone with Bluetooth® function

ATTENTION!

Respect law requirements regarding the use of the phone in the car.

5.2.1. The phone shall be switched off in the areas with restriction to use cell phones! Consider acting instructions and prescriptions.

5.2.2. Audio system supports the following services:

- **Bluetooth®** version 1.1 specification and later (recommended 2.1+EDR);
- HFP (Hands Free Profile) version 1.0 or later;
- A2DP (Advanced Audio Distribution Profile) version 1.0 or later.

5.2.3 If cell phone does not support HFP, it is impossible to register cell phone and use A2DP service separately.

5.2.4. Before connecting, make sure that the phone has **Bluetooth®** function.

5.2.5. To connect to audio system activate **Bluetooth®** function on the phone. If your phone is discoverable, turn on this mode. It is recommended also to read user manual of your phone to get additional information on setting and connection of **Bluetooth®** devices.

5.2.6. To connect your phone to radio system it is necessary to activate search of new **Bluetooth®** devices on your phone. In the list of **Bluetooth®** devices choose MMC12. If password requested input «0000».

Note. To make this operation read user manual of your phone.

5.2.7 When the phone is connected, BT sign will be indicated on the screen (Fig. 3, pos.7).

5.2.8. The radio system is able to work only with one phone simultaneously. To connect another phone it is necessary to deactivate **Bluetooth®** function on connected one and connect other phone.

Note. Some cell phones may work incorrectly in **Bluetooth®** mode with this radio that is not a sign of malfunction. Check functionality of radio system with other cell phone.

¹Bluetooth® ( Bluetooth®) is a registered trademark of Bluetooth SIG, Inc. corporation.

5.2.9. The correct functioning is not guaranteed with a cell phone with two and more sim-cards. It is recommended to consult phone user manual.

5.3 Phone disconnection

5.3.1 You may disconnect cell phone as follows:

- Switch off **Bluetooth®** function on your cell phone;
- press and hold  button (Fig. 2, pos. 13).

Note. If the phone is disconnected during a call, the call will automatically switch from loudspeakers to cell phone.



5.4 Phone call

5.4.1. If a call comes to cell phone in the lower part of the screen appears calling number (this function depends on service package provided by your mobile operator).

5.4.2. Call acceptance is made by pressing the  button (Fig. 2, pos. 10).

5.4.3. To decline or finish the call press the  button (Fig. 2, pos. 13).

5.4.4. During phone call it is possible:

- to modify volume by encoder handle (pos. 6);
- to accept incoming call by pressing  button (Fig. 2, pos. 10);
- to end the call pressing  button (Fig. 2, pos. 13).

5.4.5 Radio system keeps the information on the last connected cell phone. In case of connection ceasing, for example during moving off from the car and returning, to connect the phone again press  button (Fig. 2, pos. 10).

Note. Not all cell phones support this function. To restore the connection **Bluetooth®** function on the phone should be active and phone should be visible (depending on the phone model).

5.5 Audio files playback via the phone

5.5.1 In **Bluetooth®** mode, in case A2DP protocol is supported by the phone, you may listen to audio files played back on the cellular phone via the vehicle audio system.

- Press button **AUDIO** (pos. 20) and chose A2DP mode;

- Start player on the phone (not all cell phones support this function).



5.5.2 Blayback control is made similar to **AUDIO** mode.

Note. Before using this function please ensure that your phone supports A2DP.

5.6 Saving and calling phone numbers

5.6.1 Your radio system saves the last incoming/outcoming number.

5.6.2 To see the last number:



- enter «Telephone» mode (pressing the  button (Fig. 2, pos. 10), pressing again the  button (Fig. 2, pos. 10), the number will be displayed on the screen;

- if you are in «Telephone» mode press  button (Fig. 2, pos. 10), the number will be displayed on the radio screen.

You may save up to 6 numbers:

- When the last incoming/outcoming phone number is displayed, press and hold one of the buttons **1–6** till the number is displayed in the middle of the line;
- There is a possibility to save current phone number during call pres-

sing and holding one of the buttons **1–6** till the number is displayed in the middle of the line.

5.6.3 To call the saved number it is necessary to pass to «Telephone» mode, shortly pressing  button (Fig. 2, pos. 10). Then chose the desired number pressing one of the buttons **1–6** and the number will be displayed in the lower line. To confirm the choice shortly press button of number dialing confirmation  (Fig. 2, pos. 10).

Note. The phone numbers saved may be deleted from memory by resetting radio system to factory settings (part 6.3 «System settings»).

6. Setting mode

6.1 Audio parameters setting

6.1.1 Press encoder short while in the «main screen» (display screen) to enter this mode.

6.1.2 Turn encoder in the following order to switch and to change parameters: Equalizer → Low Frequency Tone → High Frequency Tone → Balance → Balance front/rear → Tone compensation → Exit.

Note. If user does not make any adjustments during 5 minutes, the setting mode turns off automatically.

6.2 Screen for adjustment of selected audio parameter

6.2.1 Press encoder in the respective menu item to enter this mode. Turn encoder knob to adjust selected parameter.

6.2.2 Equalizer is set in the following order:

EQ JAZZ → EQ POP → EQ CLASSICS → EQ VOCAL → EQ USER.

6.2.3 Tone adjustment range LF, HF, Balance, Balance front/rear is from «-7» to «+7» units.

6.3 System settings

6.3.1 By means of system settings you can:

– set time displaying format (time mode);

– set the current time manually (hours/minutes setting);

– turn on/off the current time adjustment by RDS signals (RDS CT);

– turn on/off the function of automatic switching to the alternative broadcast frequency (RDS AF);

– turn on/off the function of radio stations seeking based on the set program type (RDS PTY);

– turn on/off the function of local stations receiving (RDS REG);

– turn on/off of mid-band range (AM- range);

– turn on/off of **Bluetooth** function (tel. connection);

– turn on/off of buttons pressing acknowledgement signal (signal);

– turn on/off of noise suppression function (noise suppression);

– reset radio settings to the factory settings (reset).

6.3.2 Press encoder long to enter system setting mode while in the «main screen» (display screen). Turn encoder to select the available settings and adjust the selected parameter. Press encoder short to adjust the selected parameter and acknowledge the setting.

6.3.3 You can quit the system settings mode through the menu item «Quit» or automatically (if no adjustments are performed during 5 minutes).

7. Non-warranty cases

7.1 Non-warranty cases are specified in the Table 4.

Table 4

Occurrence	Typical place of occurrence	Cause
Liquid spilled on unit (inside it)	Flow marks from outside and inside of unit. Smoke fume	Violation of operation rules for unit
Smoke fume	Surface of unit, inside the part	Incorrect connection, downfall, unauthorized repair, ingress of liquid into the unit
Breaking of seals, geometry or initial state of unit surface	Junction of unit components (fractures, cracks), stripped fastener nicks	Opening (or attempt to open) without special instrument. Unauthorized opening
Traces of insects or animals	Surface, inside	Cockroaches, ants, bugs, hairs, etc.
Broken operating controls	Buttons and controls	Mechanical action (impacts, downfalls, etc.), Careless use
Impossibility of identification of serial number. Erased, failed number and trademark sticker	Spots of factory labels and trademark stickers	Mechanical, thermal action, etc. Unauthorized opening
Chips on unit frame, cracks	Frame corners, rear part of covering, fixture of support, trays, covers, tubes	Mechanical action (impact, downfalls, careless operation, etc.)
Mechanical damage of radio component (ERI) in a unit, and of current-carrying tracks		Violation of operation rules. Careless operating
Electrical damage of ERI or of current tracks, detected visually		Faulty fitting of junction elements, operation of unit under non-standard (undocumented) modes
Non-availability of authorized ERI at their respective places, availability of fixed non-authorized ERI. Soldering prints		Violation of operation rules. Attempt of independent repair

Table 4 continued

Occurrence	Typical place of occurrence	Cause
Intense dust pollution or contamination of unit, condensate inside the unit. Organic and non-organic deposits	Inside the unit. Surface	Operation of unit under conditions not designed for this class of products
Foreign objects inside the unit (paper clips, pins, etc.) (Applicable to products with ventilation holes or channel for access without product opening)		Violation of operation rules
Deformation of cables connectors, deformation of connecting cables or heir visually detected damage	Connecting cables and connectors	Gross mechanical impact, careless connection, misalignment during installation
The unit doesn't get started, hangs up at LADA logo, white screen	FLASH memory chip	Software is damaged. User's attempt to reprogram
The display is broken; there are cracks or scratches on display	Unit surface	Mechanical action (impacts, downfalls, etc.)
Damage of anti-reflective, tinted coating of display	Display surface	External action of «aggressive» liquids (aerosol spraying close to the screen). Use of inappropriate technical liquids to clean the display screen
Burrs in the area of fastening elements of «latch» type	Unit case, unit surface	Attempt of independent repair
Traces of mounting tool on the splines of screw connection elements of the case or close to them	Unit case, unit surface	Attempt of independent repair

End of Table 4

Occurrence	Typical place of occurrence	Cause
The screen does not respond to pressing	Display	Mechanical action (impacts, downfalls, etc.)
Distorted colors (red, green and similar colors of the screen)	Display	Mechanical action (impacts, downfalls, etc.)
No connection to the phone, unstable operation of the Bluetooth function		Individual incompatibility of phone and unit
Radio stations seeking doesn't work	Antenna cable	Antenna cable rupture. Incorrect installation of the unit on the car
After the installation of USB-flash drive with audio files the unit doesn't detect files in the audio player screen (doesn't go to the audio player mode)	USB-cable	USB-cable rupture. Incorrect installation of the unit on the car. Unsupported type of USB-drive
After installing SD card with audio files on it, audio player window not detecting files (not switching to audioplayer mode)		Unsupported type of SD-card
No video files playback, slow motion playback of video files, no sound/ no mage during playback, video and audio out of synchronization during video files playback		Unsupported video files format
Hang-ups, unstable operation fixed by restarting of the unit (by long pressing on the power button)		

List of radio broadcasts transmitted within RDS system

Nº	Program type	Display image
1	News	NEWS
2	Miscellanea	VARIED
3	Pop music	POP MUSIC
4	Rock music	ROCK MUSIC
5	Other music	OTHER MUSIC
6	Children's programs	CHILDREN'S PROGRAMMES
7	Leisure	LEISURE
8	Jazz music	JAZZ MUSIC
9	Old hits	OLDIES MUSIC
10	News	FOLK MUSIC

**Search parameters
with RDS modes**

1. When **RDS** modes are on (**AF**, **PTY** on display) automatic search is done in accordance with selected mode.

2. In **PTY** mode only radio stations, which support **RDS** and transmit programs meeting the user set type can be searched.

3. For sequential search for all available stations in the selected range deactivate the **PTY** modes, i.e. **PTY**.

Correct connection conditions

1. Only connection of USB devices with 2.0 specification is possible.

2. The file table (FAT) of the connected device should be FAT16 (< 2 GB) or FAT32 (> 2 GB). Maximum number of primary sections is 4.

3. At reproducing a record from a large external storage a delay can occur due to reading of the file structure.

4. At reproducing a record from a too branched directory structure, a delay can occur due to reading of the file structure.

5. Recommended directory structure of connected device is maximum eight levels. Maximum 1000 files in one directory.

6. The radio meets the following formats of external storage:

SDHC до 32 Gb;

SD до 32 Gb;

USB 2.0 до 64 Gb;

USB 3.0 до 64 Gb.

SD card slot: supports SD, SDHC cards 32 × 24 × 2.1 mm.

Note. More files/folders on the storage – longer time of loading. It is recommended to use a storage, which contains only audio files.

7. For maximum speed of access to files, it is recommended to use SD-cards class 4 and higher.

ATTENTION!

Do not use extension USB-cables and USB-hubs for connection of device.

8. The radio supports the following audio files:

*. **MP3.** With constant or variable bit rate, the transmission rate 32-320 kb/s and sampling rate 44.1/48 kHz;

*. **WMA.** (w/o DRM). With constant bit rate and transfer rate of 10-320 kb/s, variable bit rate and transfer rate 32-192 kb/s.

Radio care

1. When cleaning the passenger compartment avoids liquids getting inside the radio. It can cause short circuit and other damages.

2. Use a soft cloth to wipe out fingerprints the display, wet it with pure alcohol if needed.

ATTENTION!

Do not use solvents – benzene, turpentine etc., they can damage the display surface.

3. Handle the display with care: strong press with your finger or a touch of sharp objects display can leave dents or scratches on display.

Fault Diagnosis

Fault	Remedy
Radio does not turn on	Make sure that supply circuit terminals are in good repair, not contaminated. Make sure that radio supply voltage is 12 V on the terminal. Make sure the temperature in passenger compartment is within acceptable limits
No Bluetooth connection between radio and mobile phone	Make sure that Bluetooth function in mobile phone is on and tuned Reload the radio, see p. 2.2.3. Make sure that «Telephone connection» in radio options is activated
Radio does not respond to pressing of buttons	Reload the radio, see p. 2.2.3
The radio receiver doesn't find any radio station	Make sure that you are within signal detection area. Reload the radio, see p. 2.2.3
The radio receiver doesn't find SD-card/USB – flash-disk	Make sure that SD-card/USB-flash-disk meets the specs (see Appendix 3). Make sure that SD-card/USB-flash-disk contains audio data. Reload the radio, see p. 2.2.3

List of abbreviations and conventions

AF	– List of Alternative Frequencies. Possibility of automated retuning of the radio, for example, in case of poor signal receiving at some frequency band, to another frequency band which also transmits the signal of selected program.
AM	– AM-band
AUDIO	– An audio term related to sound files transmission technologies
A2DP	– Bluetooth® profile used to reproduce the music saved in telephone memory through the radio
BAL	– Balance
BASS	– Low frequencies sound tone
Beep	– Signal
BT	– Bluetooth provide for data exchange between devices
CT	– RDS function used to correct time by signals of radio stations
DISP	– Display
EQ	– Equalizer
FAD	– Front/rear speakers balance
F+	– Go to next folder
F–	– Go to previous folder
FM	– FM-band
MUTE	– Sound shutoff
RDM	– Random reproduction mode (Random)
RPT	– Repeated reproduction mode (Repeat)
SCAN	– Scanning
SD	– Secure Digital Memory Card format
TAG	– Metadata of audio file
TRE	– High frequency sound tone
USB Flash drive	– USB (Universal Serial Bus – flash drive – data store)
VHF	– Very high frequency band

Frequently asked questions

What is stream audio- Bluetooth or A2DP?

A2DP – Advanced Audio Distribution Profile. It is used to transfer stereo sound by Bluetooth radio channel to any receiving device, for example, from a telephone or MP3-player to another device, such as a radio. The radio supports audio data transfer using the A2DP technology.

How do I know if my device supports stream audio Bluetooth?

Please refer to the device user manual to ensure that it supports A2DP.

What mobile phones can be connected through Bluetooth?

Most mobile phones can connect through Bluetooth.

What is Bluetooth?

Bluetooth – wireless standard, which allows to connect two devices to each other. It is used for applica-

tions and allows to connect two devices which can have objects between them. The connection can be set in a range of about 10 meters. The connection can be kept even if one of the devices is in your bag or pocket.

If Bluetooth is a standard, why not all phones can work with the system?

Unfortunately, though Bluetooth is a standard, it is up to the manufacturer to use it in the phone. Often some unique functions are added to differentiate the product, it can cause incompatibility. In some cases incompatible software can be installed on the phone in process of its use, this interrupts compatibility.

If a phone does not work with the radio installed in the car, the user most often blames the car equipment but not the phone. Sometimes upgrading of the phone software can solve the problem.

What Bluetooth versions are supported?

Bluetooth standard has many versions, which ensure certain functions. The radio meets Bluetooth V 2.0 standard and includes the following standards:

- standard access profile GAP V 2.0;
- Advanced audio distribution profile A2DP V 1.2.

Автомобиль LADA Granta и его модификации

Руководство по эксплуатации на английском языке

(состояние на 03.02.2016 г.)

ДТР ОАО «АВТОВАЗ»

Разработчики: *Ю.В.Сабанов, Н.В.Казаков, А.В.Мингачев*

Художник *Е.И.Брейкин*

Корректор *Н.С.Фомина*

Компьютерная верстка *Т.В.Лисина*

Формат 60x90¹/₁₆. Объем 8,5 п.л. Заказ 772. Тираж 80.
Отпечатано ООО «Двор печатный АВТОВАЗ». Февраль 2016 г.

21900-3902012-30
АНГЛИЙСКИЙ ЯЗЫК

