

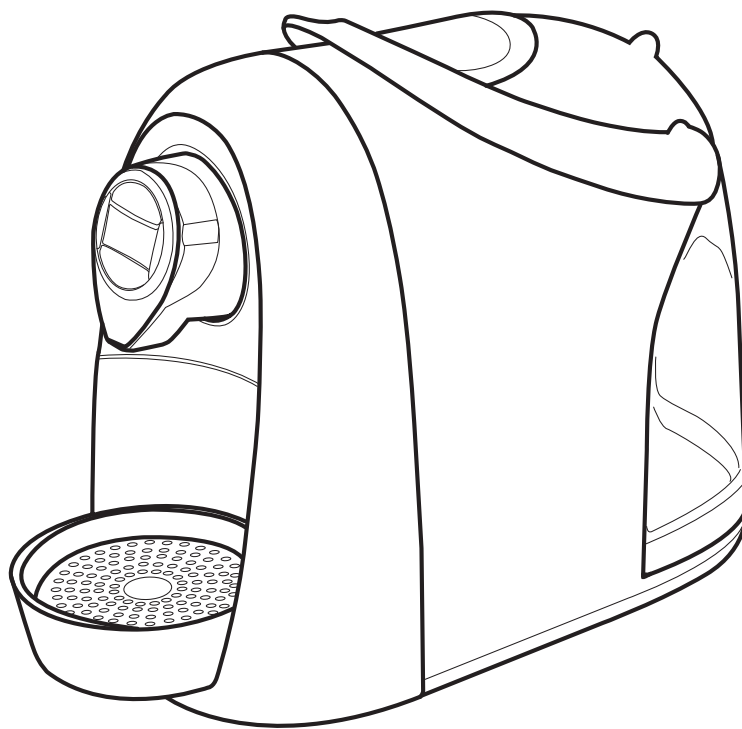

Manuale di istruzioni
Instruction book
Mode d'emploi
Bedienungsanleitung



Italiano **English** **Français** **Deutsch**

Model S04



Introduzione

●	Usò conforme alla destinazione	3
●	Simboli di avvertenza	3
●	Il vostro contatto Caffitaly System	3
●	Avvertenze di sicurezza	4
●	Istruzioni per l'uso e lo smaltimento.....	5
●	Descrizione componenti macchina	6

Installazione

1	Al primo utilizzo o dopo un lungo periodo d'inutilizzo	7
2	Accendere l'apparecchio.....	8
3	Segnalazioni generali di funzionamento	9
4	Regolazione altezza tazza/tazzina	11

Erogazione prodotto

5	Erogazione caffè	12
6	Erogazione di altre bevande	13
7	Programmazione quantità caffè in tazza	14

Pulizia e manutenzione

8	Pulizia giornaliera	15
9	Decalcificazione	16

Varie

10	Soluzione dei problemi	20
11	Dati tecnici	20

Gentile cliente,

grazie per aver scelto il nostro prodotto e per la fiducia accordataci. Con la nostra macchina potrete gustare le vostre bevande calde preferite in ogni momento della giornata, scegliendo tra le varie capsule che Caffitaly vi offre. Per esempio: Un caffè espresso, o una bevanda al gusto Cacao o un Tè, saranno pronti in pochi secondi.

Uso conforme alla destinazione

Questo apparecchio è destinato ad essere utilizzato in applicazioni domestiche e similari come ad esempio:

- aree cucina personale in negozi, uffici e altri ambienti di lavoro;
- agriturismo;
- dai clienti in alberghi, motel e gli altri ambienti di tipo residenziale;
- ambienti del tipo "bed and breakfast".

Utilizzare esclusivamente le apposite capsule specifiche per il sistema Caffita. Qualsiasi altro utilizzo non previsto da queste istruzioni può essere causa di danni alle persone e far decadere la garanzia. Il costruttore non risponde per danni derivanti da un uso improprio dell'apparecchio.

Simboli di avvertenza



ATTENZIONE

Questo è il simbolo di avvertenza sicurezza. È utilizzato per richiamare l'attenzione su possibili rischi di ferite personali. Attenersi ai messaggi di sicurezza indicati per evitare possibili ferite o morte.



NOTA BENE

Questo è il simbolo che viene utilizzato per evidenziare alcune azioni che migliorano l'utilizzo della macchina.



Non lavabili in lavastoviglie



Consigli per la pulizia



Questo simbolo viene utilizzato per mettere in evidenza una segnalazione luminosa **BIANCA**.



Questo simbolo viene utilizzato per mettere in evidenza una segnalazione luminosa **ROSSA**.



Questo simbolo viene utilizzato per mettere in evidenza una segnalazione luminosa **ARANCIONE**.

Avvertenze di sicurezza

Leggere con attenzione le seguenti istruzioni! Eviterete così i rischi di infortuni e danni all'apparecchio.

- Dopo aver tolto l'imballaggio, assicuratevi dell'integrità dell'apparecchio. In caso di presenza di danni, o al primo segnale di difettosità (rumori o odori insoliti), o per qualsiasi problema riscontrato all'interno dell'apparecchio, non utilizzarlo e rivolgersi ad un Centro Assistenza Autorizzato.
- Gli elementi dell'imballaggio (sacchetti in plastica, ecc.) non devono essere lasciati alla portata dei bambini in quanto potenziali fonti di pericolo.
- Utilizzare l'apparecchio solo se il cavo di alimentazione è intatto. Per la sostituzione del cavo, se danneggiato, rivolgersi esclusivamente ad un Centro Assistenza Autorizzato. Pericolo di morte per scosse elettriche.
- Conservare ed utilizzare l'apparecchio solo in locali interni. Assicurarsi che gli elementi elettrici, spine e cavi siano asciutti. Mai immergere l'apparecchio. Proteggere l'apparecchio da schizzi o gocciolamenti. Elettricità e acqua insieme provocano pericolo di morte per scariche elettriche.
- Collegare l'apparecchio solo a prese di corrente a norma di legge. Assicurarsi che la tensione della rete elettrica corrisponda a quella indicata nella targhetta dati sul fondo dell'apparecchio.
- Il piano sul quale viene installata la macchina deve essere livellato, solido, fermo e resistente al calore; il piano d'appoggio non deve superare i 2° d'inclinazione.
- Non consentire l'uso dell'apparecchio a persone (anche bambini) con ridotte capacità psico-fisico-sensoriali, o con esperienza e conoscenze insufficienti, a meno che non siano attentamente sorvegliate e istruite da una persona responsabile della loro incolumità. Sorvegliare i bambini, assicurandosi che non giochino con l'apparecchio!
- Non lasciare il cavo di alimentazione vicino a superfici calde, a spigoli o oggetti taglienti.
- Mai mettere le mani dentro il vano portacapsule. Pericolo di lesioni
- Richiudere sempre la leva. Mai aprire la leva quando l'apparecchio è in funzione.
- Mai rimuovere parti della macchina. Non inserire alcun oggetto nelle aperture. Questo potrebbe causare scosse elettriche! Qualsiasi intervento non illustrato in queste istruzioni deve essere eseguito solo da un Centro Assistenza Autorizzato!
- Non staccare il cavo di alimentazione tirandolo, ma estrarre la spina per evitare danni alla presa

- Procedere con la decalcificazione ad intervalli regolari, come indicato dalle istruzioni. In caso contrario l'apparecchio potrebbe danneggiarsi e potrebbe provocare danni alla salute.
- Pulire scrupolosamente e regolarmente l'apparecchio. Il deposito che si crea in caso di mancata pulizia, potrebbe essere dannoso per la salute. Scollegare l'apparecchio e lasciarlo raffreddare prima di procedere alla pulizia.
- Nel caso si preveda di non utilizzare l'apparecchio per lunghi periodi (vacanze, ecc.), scollegare la spina dalla presa elettrica.

Istruzioni per l'uso e lo smaltimento



L'apparecchio è costruito con materiali di alta qualità che possono essere riutilizzati o riciclati. Smaltire l'apparecchio in un apposito centro di raccolta.



Per escludere qualsiasi abuso e pericoli coinvolti, fate in modo che la macchina non sia collegabile alla rete elettrica prima di consegnarlo al servizio rottamazione. A questo scopo scollegare l'apparecchio dalla presa di corrente staccando la spina, e tagliare il cavo alimentazione il più vicino possibile alla macchina.



Avvertenze per il corretto smaltimento del prodotto ai sensi della direttiva europea 2002/96/EC e del Decreto Legislativo n. 151 del 25 Luglio 2005. Alla fine della sua vita utile il prodotto non deve essere smaltito insieme ai rifiuti urbani. Può essere consegnato presso gli appositi centri di raccolta differenziata predisposti dalle amministrazioni comunali, oppure presso i rivenditori che forniscono questo servizio. Smaltire separatamente un elettrodomestico consente di evitare possibili conseguenze negative per l'ambiente e per la salute derivanti da un suo smaltimento inadeguato e permette di recuperare i materiali di cui è composto al fine di ottenere un importante risparmio di energia e di risorse. Per rimarcare l'obbligo di smaltire separatamente gli elettrodomestici, sul prodotto è riportato il marchio del contenitore barrato. Lo smaltimento abusivo del prodotto da parte dell'utente comporta l'applicazione delle sanzioni amministrative previste dalla normativa vigente. L'imballo è in materiale riciclabile. Rivolgersi alle autorità competenti per informazioni relative alla normativa locale.

Descrizione componenti macchina

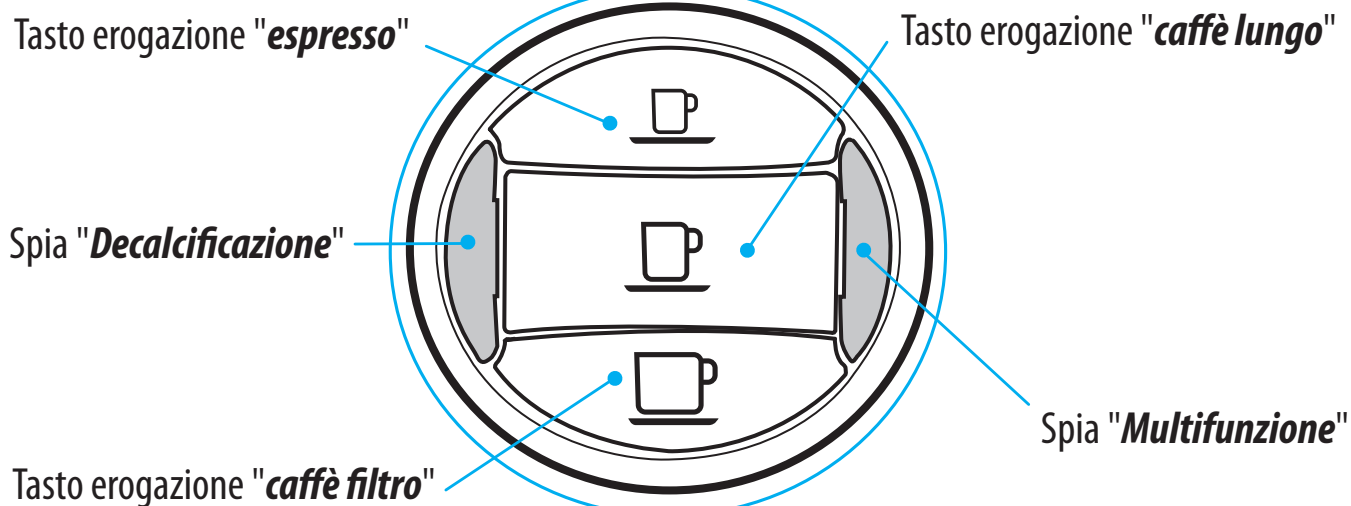
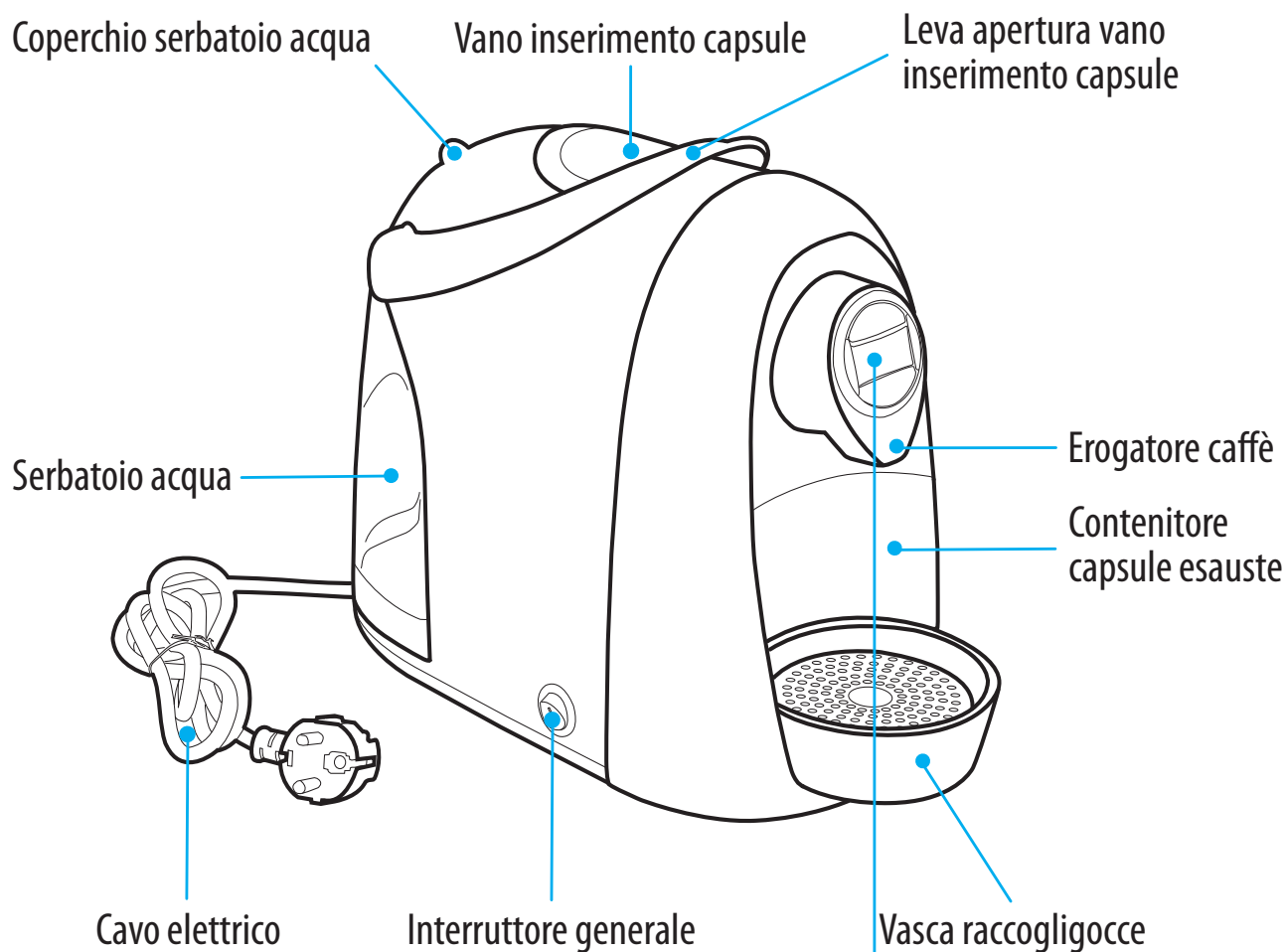

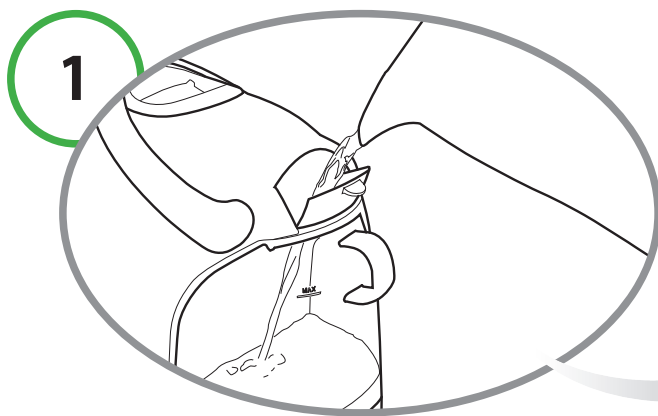

Riempire il serbatoio con acqua fresca (non gasata).

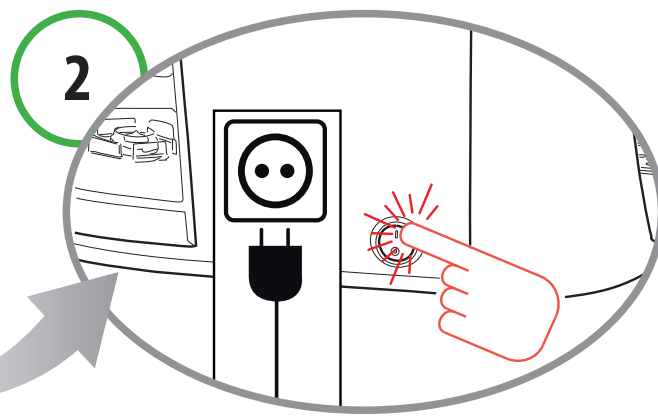

Inserire la spina nella presa di corrente e accendere l'apparecchio.

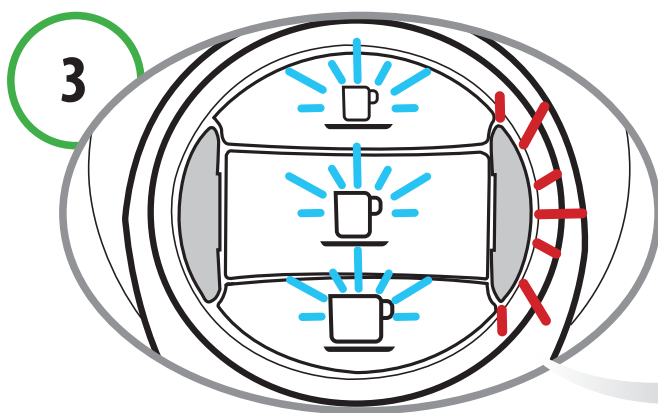

I tasti (**espresso**, **caffè lungo** e **caffè filtro**) e la spia multifunzione lampeggiano contemporaneamente.

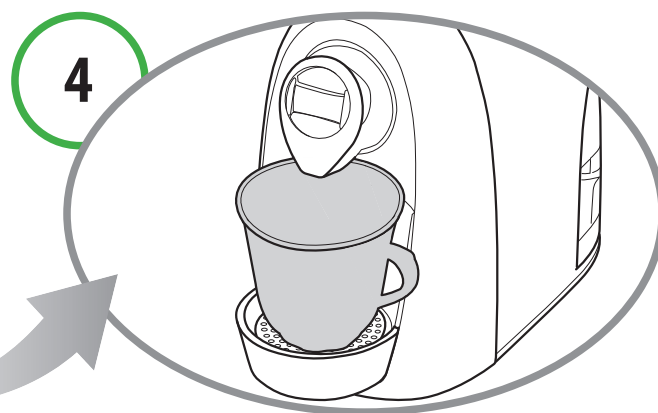

Posizionare un contenitore capiente sotto all'erogatore.

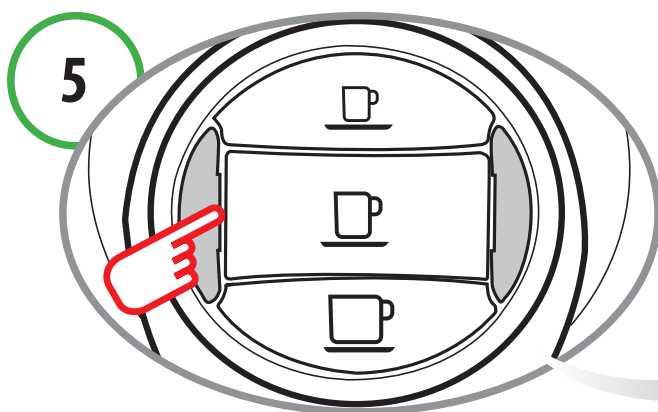

Premere uno dei tasti caffè (**espresso**, **caffè lungo** o **caffè filtro**). Attendere che la macchina termini il ciclo di caricamento del circuito idraulico. La spia **multifunzione** si spegne.

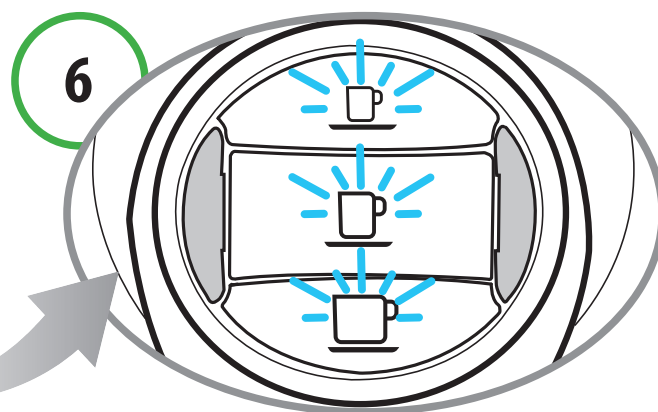

I tasti (**espresso**, **caffè lungo** e **caffè filtro**) lampeggiano contemporaneamente; la macchina è in fase di riscaldamento.



NOTA BENE:

Nel caso in cui al termine del caricamento, i tasti caffè e la spia **multifunzione** continuino a lampeggiare, ripetere le operazioni del punto 5.

2 Accendere l'apparecchio

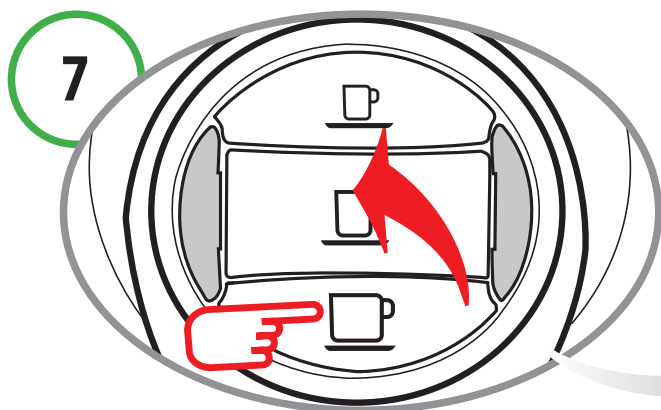

Quando i tasti (**espresso**, **caffè lungo** e **caffè filtro**) si accendono in modo fisso, effettuare due risciacqui, premendo il tasto **caffè filtro**. Attendere che la macchina termini il ciclo di risciacquo.

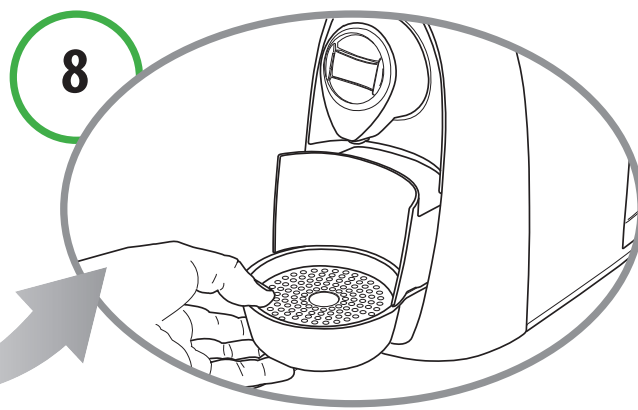

Al termine dell'operazione vuotare il cassetto capsule esauste dall'acqua.

2 Accendere l'apparecchio

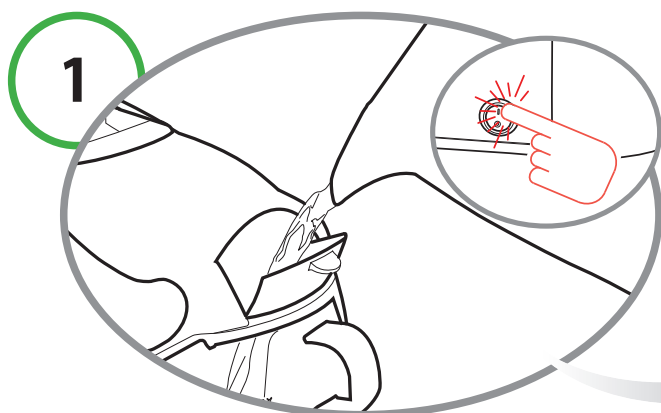

Riempire il serbatoio con acqua fresca (non gasata). Accendere l'apparecchio.

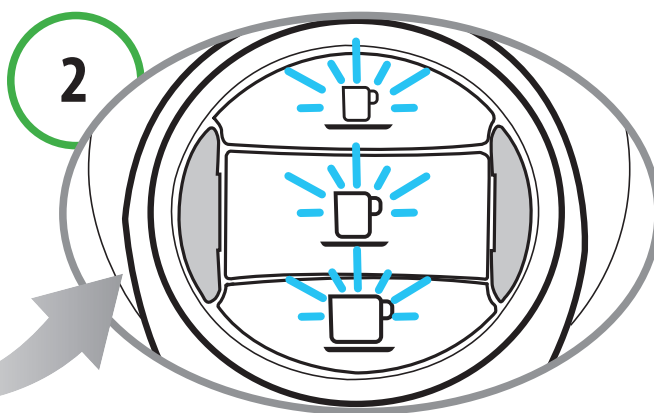

I tasti (**espresso**, **caffè lungo** e **caffè filtro**) lampeggiano contemporaneamente; la macchina è in fase di riscaldamento. Quando i tasti restano accesi in modo fisso, la macchina è pronta per l'utilizzo.

Segnale Decalcificazione

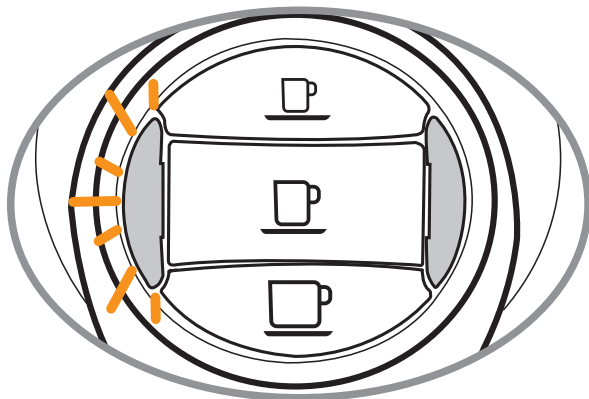

Quando la spia **decalcificazione** lampeggia in colore ARANCIONE e la macchina emette 3 segnali sonori, si consiglia di eseguire il ciclo di decalcificazione (Vedere cap. 9).

Riscaldamento

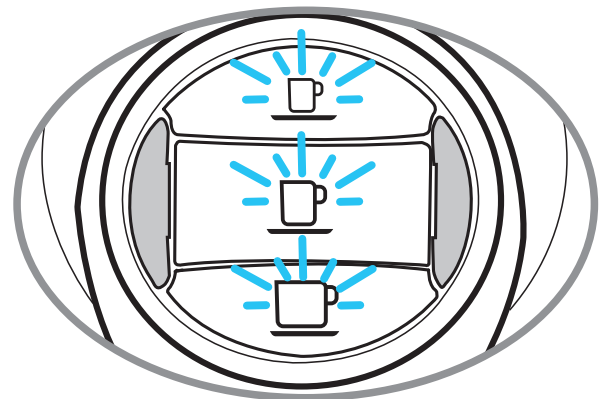

I tasti (**espresso**, **caffè lungo** e **caffè filtro**) lampeggiano contemporaneamente.

Quando si esaurisce l'acqua durante il funzionamento

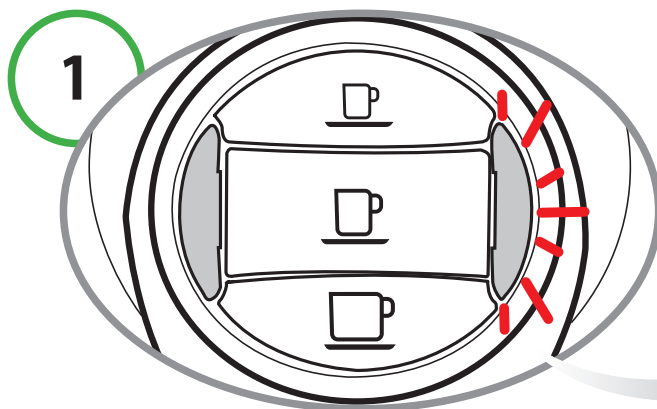

Quando la spia **multifunzione** lampeggia in colore ROSSO e la macchina emette 3 segnali sonori iniziali e successivamente uno ad intermittenza, il serbatoio acqua è vuoto.

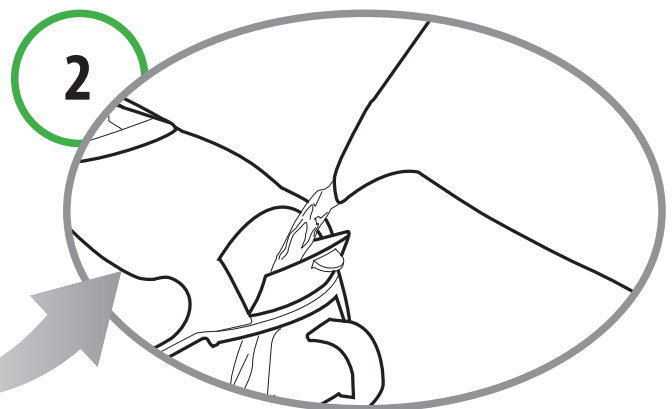

Riempire il serbatoio con acqua fresca (non gassata).

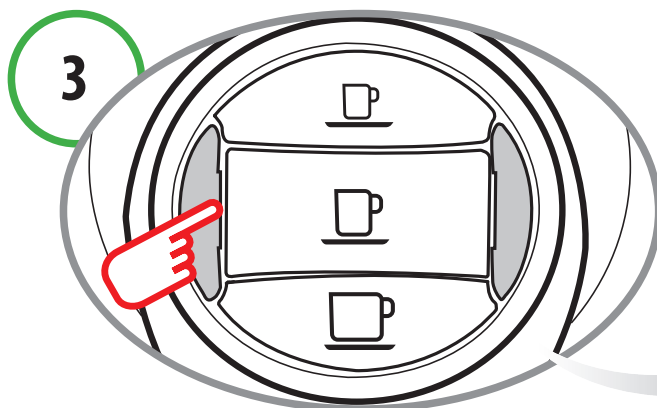

Premere uno dei tasti del caffè (**espresso**, **caffè lungo** o **caffè filtro**). Attendere che la macchina termini il ciclo di caricamento del circuito idraulico.

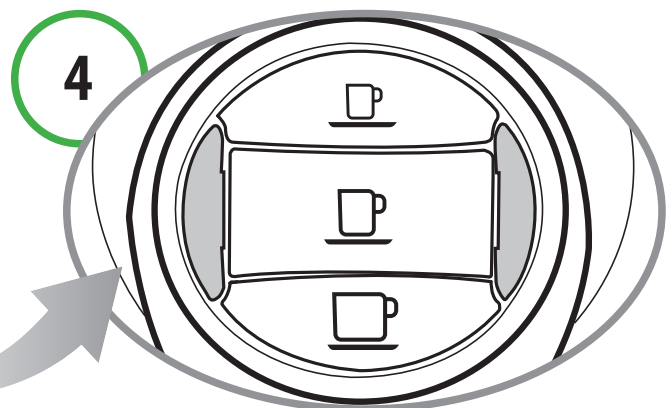

Quando i tasti restano accesi in modo fisso, la macchina è pronta per l'utilizzo.

Se viene sollevata la leva



ATTENZIONE!
Sollevando in maniera inopportuna la leva durante l'erogazione di un prodotto, si può avere l'emissione di brevi spruzzi di acqua calda.
Pericolo di ustioni!

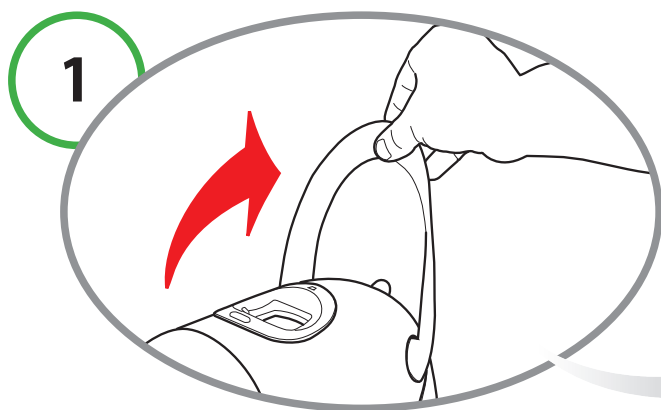

Se la leva viene sollevata durante l'erogazione di un prodotto.

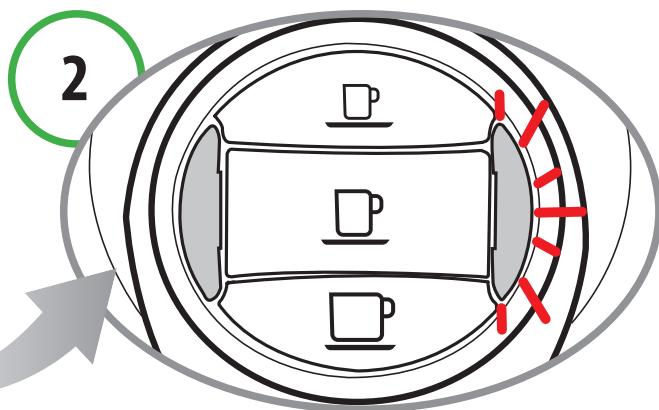

La spia **multifunzione** lampeggia in colore ROSSO e viene emesso un segnale sonoro intermittente. L'erogazione viene interrotta immediatamente.

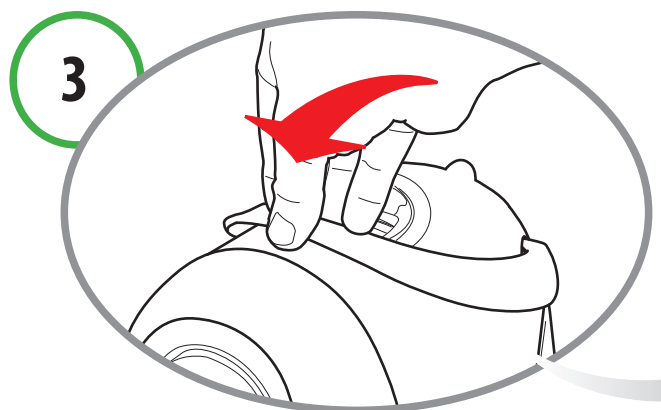

Chiudere la leva

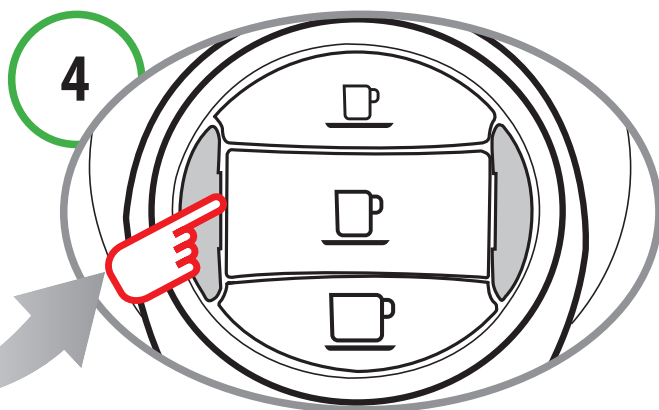

Premere un tasto per resettare l'allarme. La macchina è pronta per l'utilizzo.

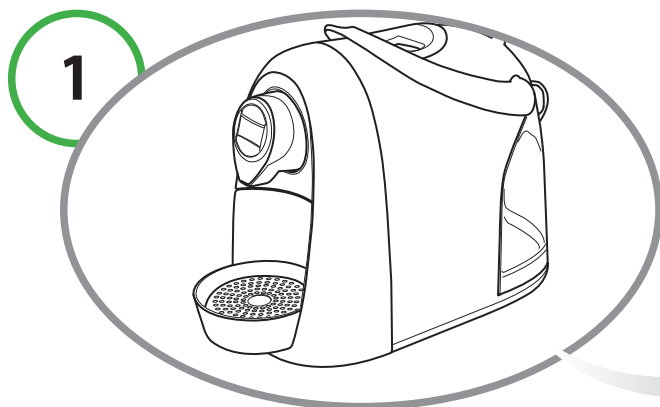

La macchina può essere regolata per consentire il corretto utilizzo delle tazze o delle tazzine.

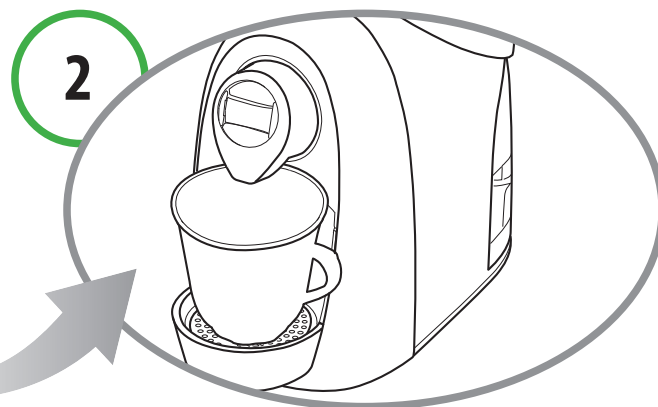

Inizialmente la macchina è predisposta per l'utilizzo di tazze grandi o mug.

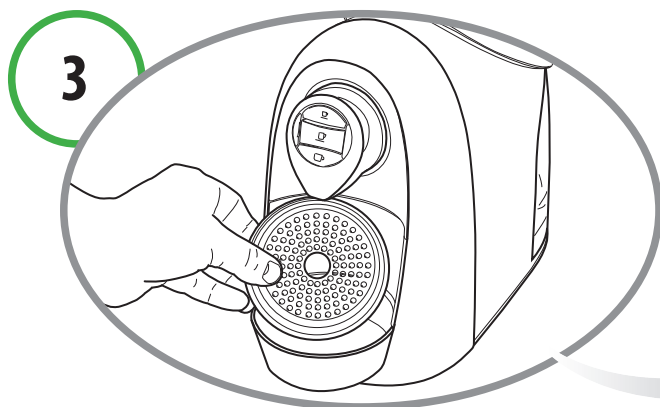

Per l'utilizzo delle tazzine, si deve sollevare e ruotare la griglia presente sopra la vasca raccogliogocce.

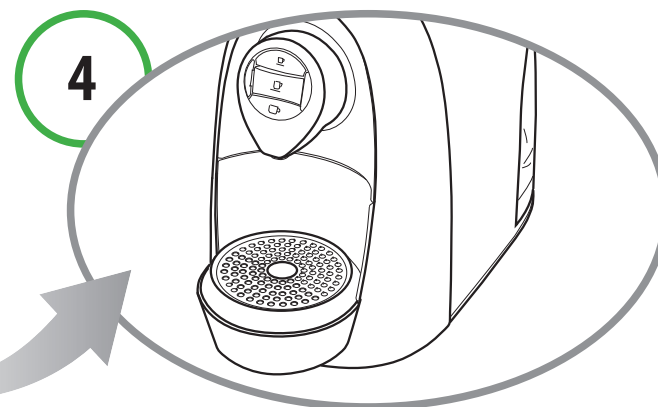

La griglia deve essere posizionata sulla vasca raccogliogocce ruotata.

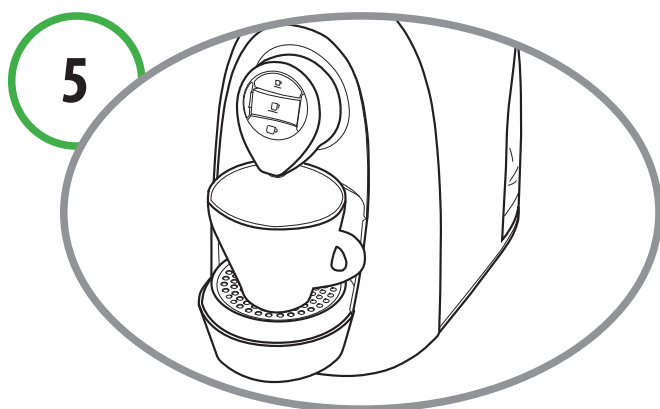

In questo modo si possono utilizzare le tazzine ottenendo un miglior risultato.



Sollevare la leva per aprire il vano inserimento capsula.

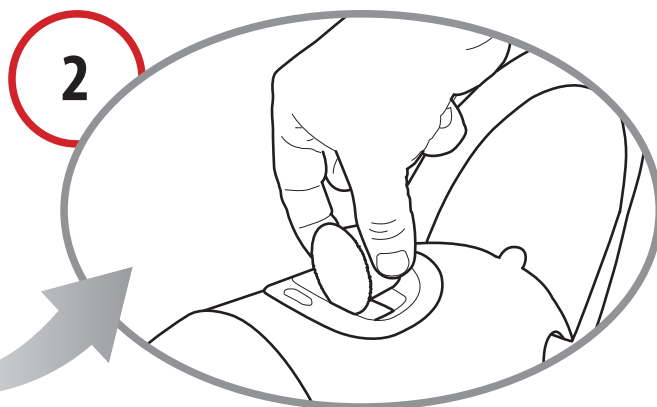

Inserire la capsula spingendola all'interno con una leggera pressione.

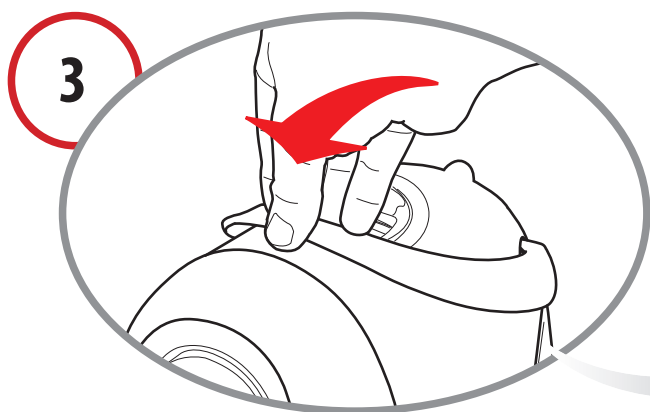

Chiudere la leva con decisione.

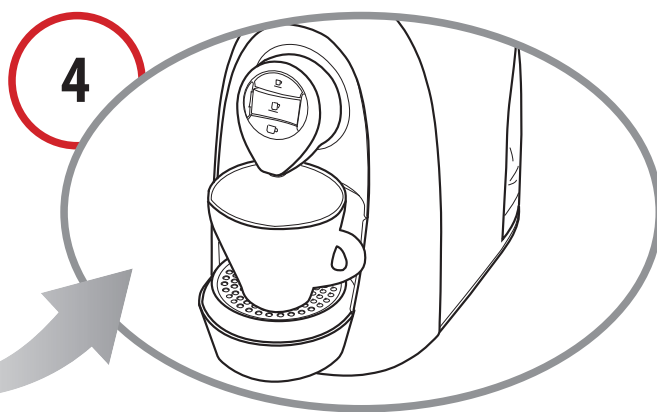

Mettere una tazza o tazzina sotto l'erogatore caffè.

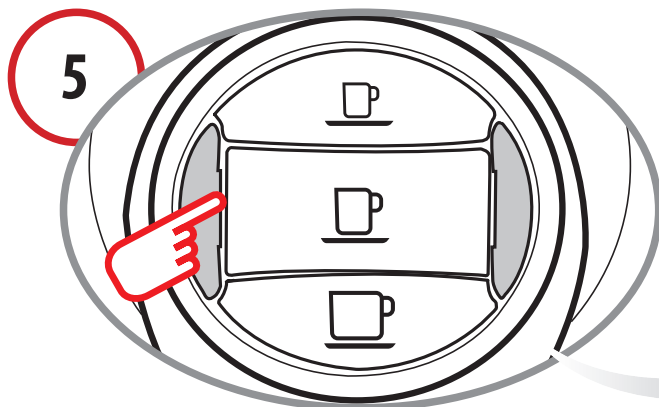

Premere una volta sola il tasto del caffè desiderato.

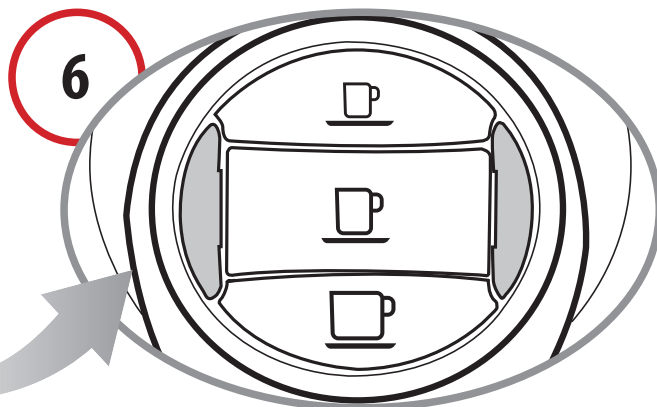

Il tasto del caffè selezionato lampeggia. L'erogazione si ferma quando viene raggiunta la quantità programmata e la macchina emette un segnale sonoro.

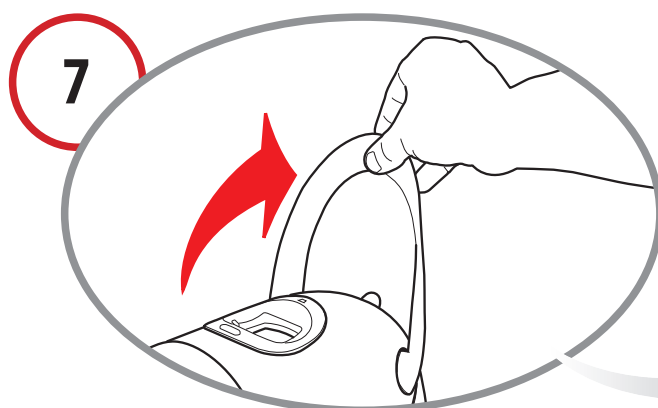

Sollevare la leva per espellere la capsula che cade nell'apposito contenitore.

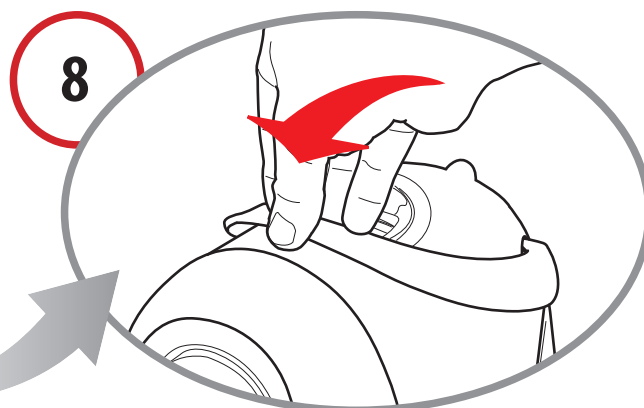

Chiudere la leva.



NOTA BENE:

Le quantità di caffè erogato si possono **ri-programmare** a piacimento secondo i gusti personali e secondo le dimensioni delle tazze o tazzine utilizzate. Per ri-programmare consultare il capitolo 7.

6 Erogazione di altre bevande

Sono disponibili capsule per preparare bevande a base di **the, camomilla, caffè filtro, ecc.** Per il loro impiego procedere come indicato nel precedente capitolo; giunti al punto 5 premere il tasto "**Caffè filtro**"

Per preparare bevande utilizzando capsule **di orzo, bevande al cacao, ecc..** procedere come indicato nel precedente capitolo; giunti al punto 5 premere il tasto "**Espresso o Caffè lungo**" a seconda delle quantità desiderate.



NOTA BENE:

Nel circuito della macchina possono rimanere tracce del prodotto appena erogato. Per salvaguardare al massimo il gusto della bevanda è consigliabile, quando si passa da un prodotto all'altro, procedere ad un breve risciacquo; il risciacquo si esegue erogando un caffè senza aver inserito la capsula.

7 Programmazione quantità caffè in tazza



Sollevare la leva per aprire il vano inserimento capsula.

Inserire la capsula spingendola all'interno con una leggera pressione.

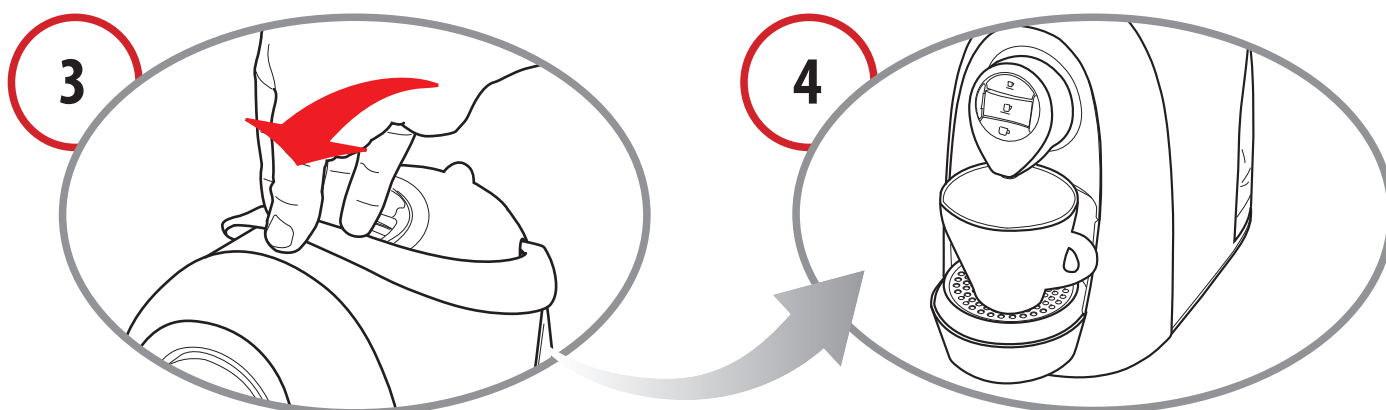

Chiudere la leva con decisione.

Mettere una tazza o tazzina sotto l'erogatore caffè.

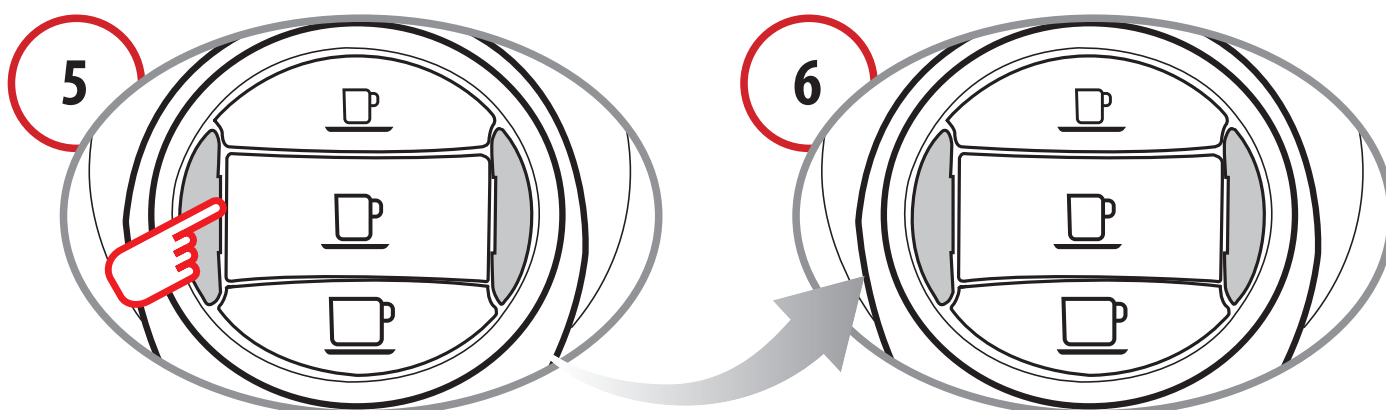

Premere il tasto del caffè desiderato e **mantenerlo premuto.**

Quando avete raggiunto la quantità di caffè desiderata in tazza, rilasciare il tasto. Ora il tasto è programmato. Per ri-programmare il tasto appena programmato o programmare un altro tasto ripetere le operazioni. **La quantità di caffè erogato, può essere programmata fino a un massimo di 250ml.**

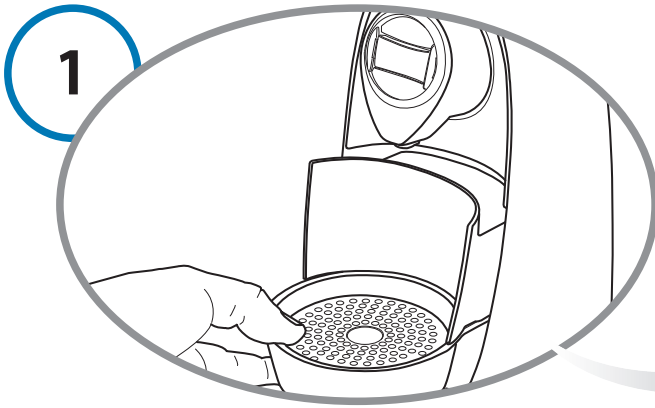

1 Estrarre la vasca raccogli gocce e il cassetto porta capsule usate.

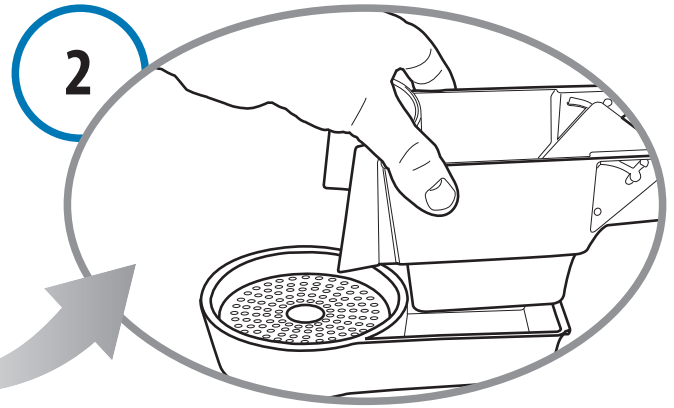

2 Sollevare il cassetto raccogli capsule; vuotarlo e risciaccarlo.

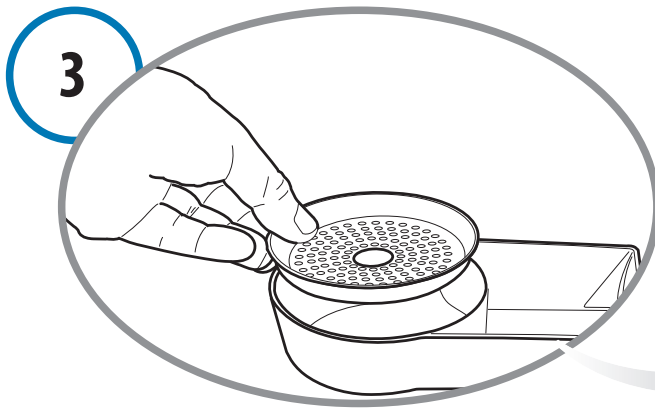

3 Rimuovere la griglia. Vuotare la vasca raccogli gocce e risciacquarla con acqua fresca..

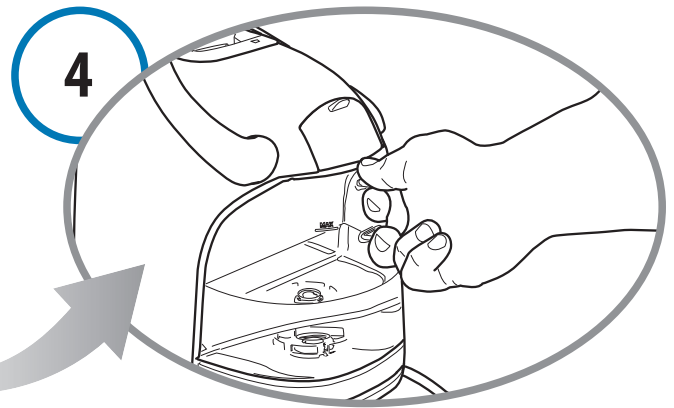

4 Rimuovere il serbatoio acqua. Svuotare e risciacquare il serbatoio. Il serbatoio NON deve essere lavato in lavastoviglie.



Per pulire la superficie dell'apparecchio utilizzare un panno morbido e un detergente neutro. Non usare getti d'acqua per la pulizia dell'apparecchio.



I componenti in plastica della macchina non possono essere lavati in lavastoviglie.

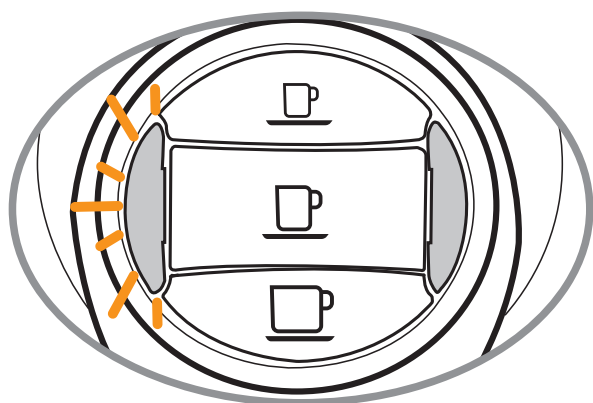

La macchina è dotata di un avanzato programma che verifica quanta acqua viene utilizzata per l'erogazione dei prodotti. Questa misurazione consente di dare indicazioni all'utilizzatore su quando la macchina necessita di un ciclo di decalcificazione. Le indicazioni specifiche vengono trattate nel capitolo 3.

Quando la spia **decalcificazione** lampeggia in colore ARANCIONE e la macchina emette 3 segnali sonori, si consiglia di eseguire il ciclo di decalcificazione (Vedere cap. 9).



Leggere con **ATTENZIONE** le precauzioni d'uso presenti sulla confezione del decalcificante. Evitare il contatto con gli occhi, la pelle e le superfici della macchina. Durante la decalcificazione non spegnere la macchina e non sollevare la leva. Deve essere presente una persona durante l'operazione.

Non usare aceto: può danneggiare la Vostra macchina!

Si raccomanda d'utilizzare il decalcificante Caffita System, che è stato studiato per rispettare le caratteristiche tecniche della macchina, in pieno rispetto della sicurezza per il consumatore. La soluzione decalcificante deve essere smaltita secondo quanto previsto dal costruttore e/o dalle norme vigenti nel Paese d'utilizzo.

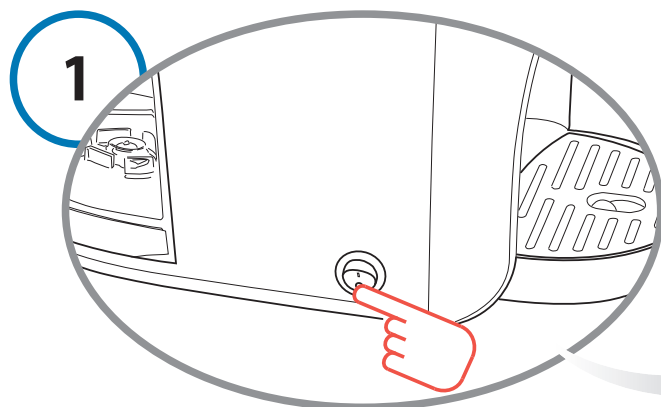

Spegnere la macchina.

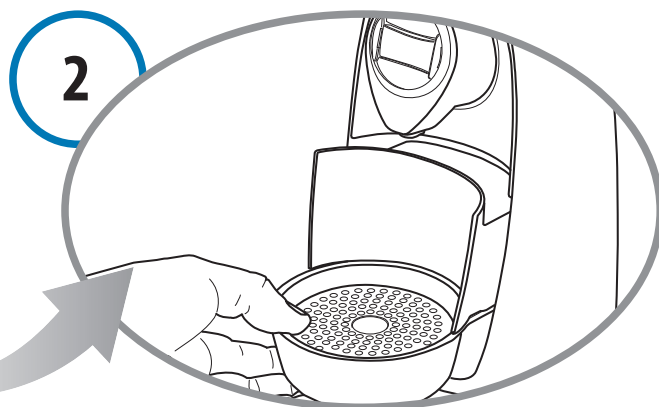

Svuotare e risciacquare il contenitore capsule esauste e la vasca raccogli gocce.

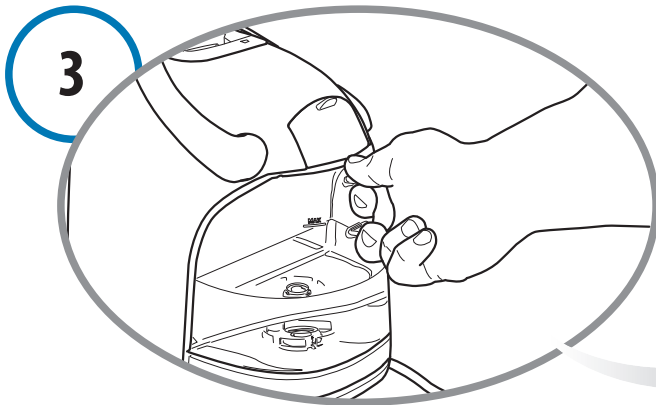

Estrarre e svuotare il serbatoio dell'acqua.

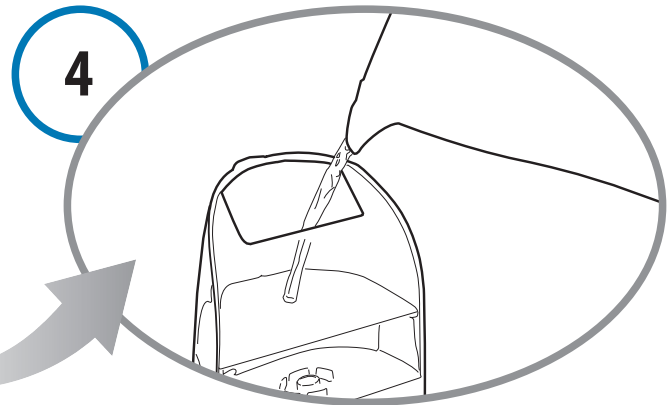

Mescolare il decalcificante con acqua come indicato sulla confezione e versare la soluzione nel serbatoio.

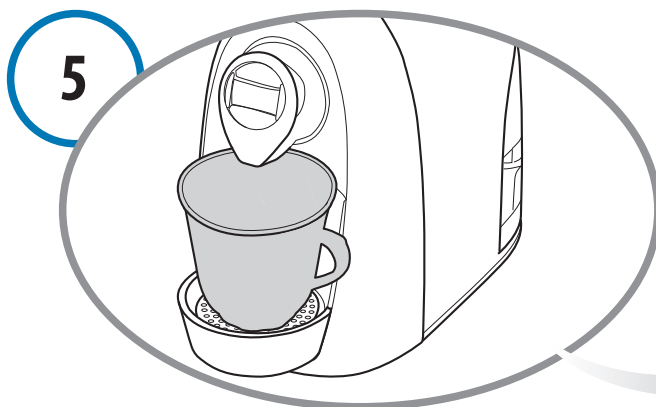

Posizionare un contenitore (almeno 250 ml) sotto l'erogatore.

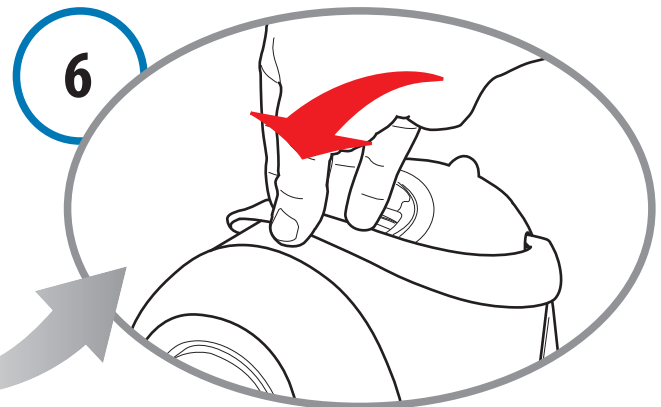

Assicurarsi che la leva sia abbassata.

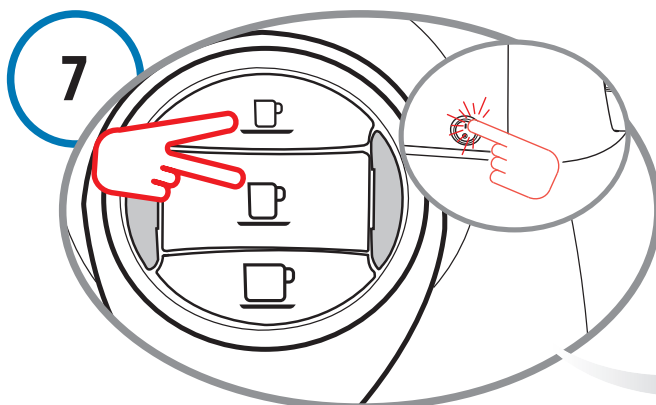

Mantere premuti i tasti (**espresso** e **caffè lungo**) e contemporaneamente accendere la macchina premendo l'interruttore generale.

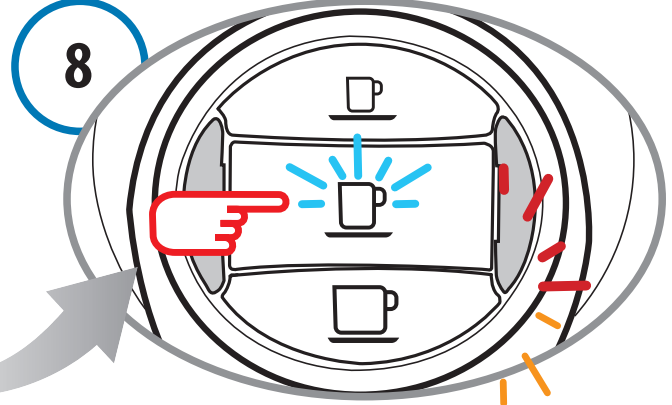

Assieme al tasto **caffè lungo** lampeggia alternata anche la spia **multifunzione** (ROSSO e ARANCIONE). Premere il tasto **caffè lungo** per iniziare il ciclo di decalcificazione.

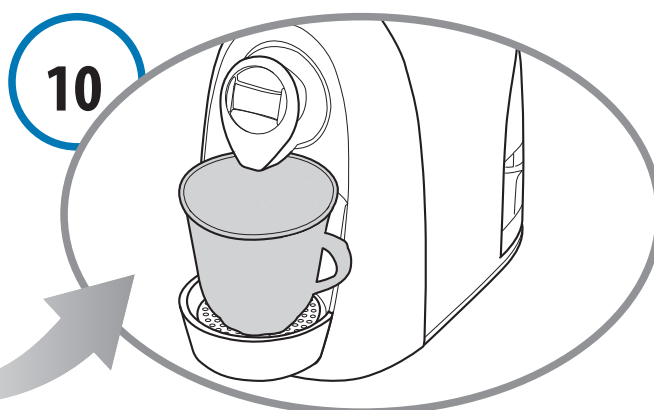
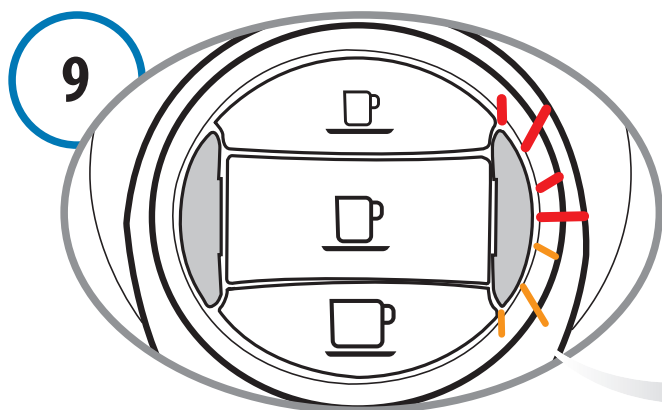

La macchina eroga la soluzione decalcificante ad intervalli (**5 erogazioni intervallate da una pausa di 10 minuti, per una durata di 45 minuti circa**). Durante questa fase, **in cui i tasti non devono essere premuti**, la spia **multifunzione** lampeggia in modo alternato (ROSSO e ARANCIONE).

Se il contenitore si riempie, provvedere a svuotarlo.

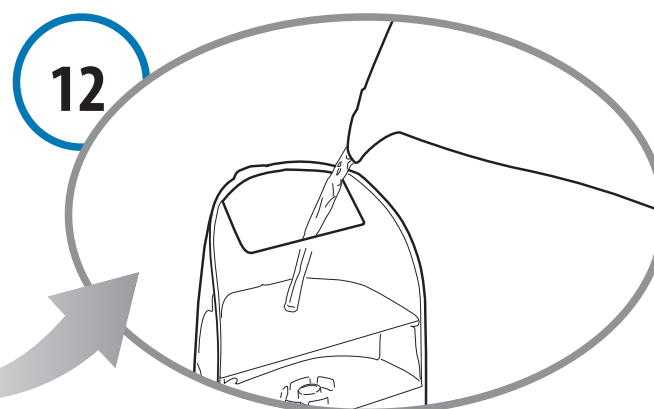
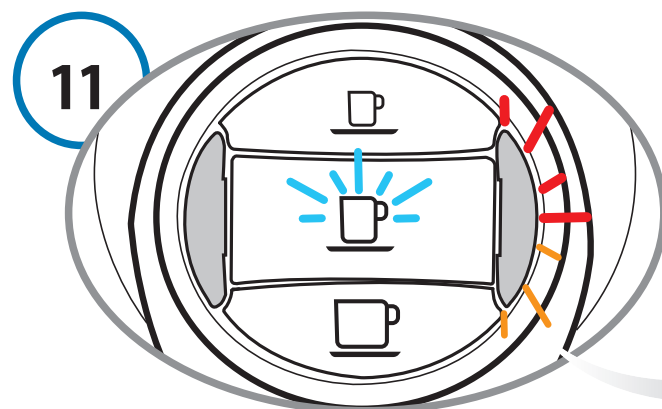

Quando il ciclo è terminato, assieme al tasto **caffè lungo** lampeggia alternata anche la spia **multifunzione** (ROSSO e ARANCIONE)

Sciquare con cura il serbatoio acqua e riempirlo con acqua potabile fresca.

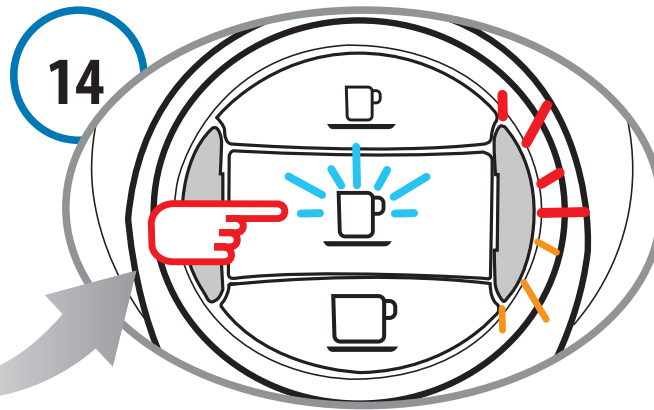
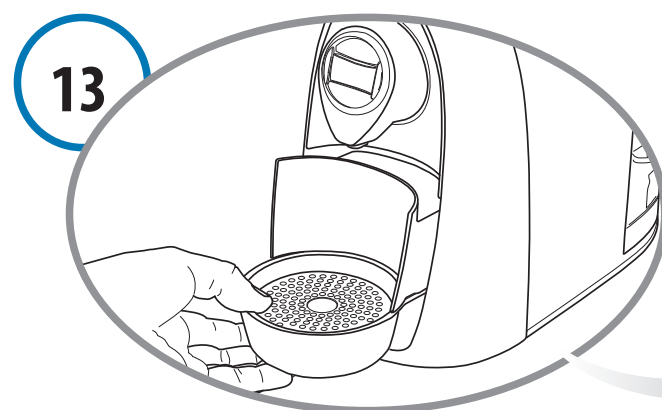

Svuotare e risciacquare il contenitore capsule esauste e la vasca raccogli gocce.

Assieme al tasto **caffè lungo** lampeggia alternata anche la spia **multifunzione** (ROSSO e ARANCIONE). Premere il tasto **caffè lungo** per iniziare il ciclo di risciacquo.

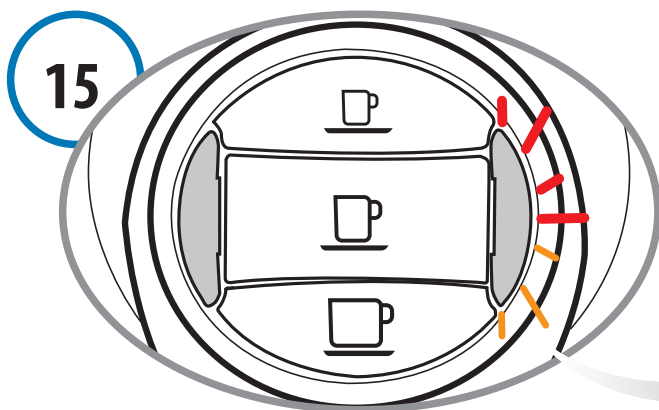

La macchina eroga l'acqua di risciacquo. Durante questa fase la spia **multifunzione** lampeggia in modo alternato (2 lampeggi alla volta ROSSO e ARANCIONE).

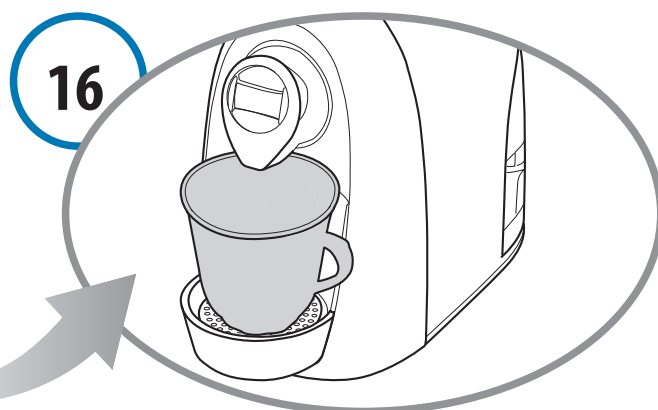

Se il contenitore si riempie, provvedere a svuotarlo.

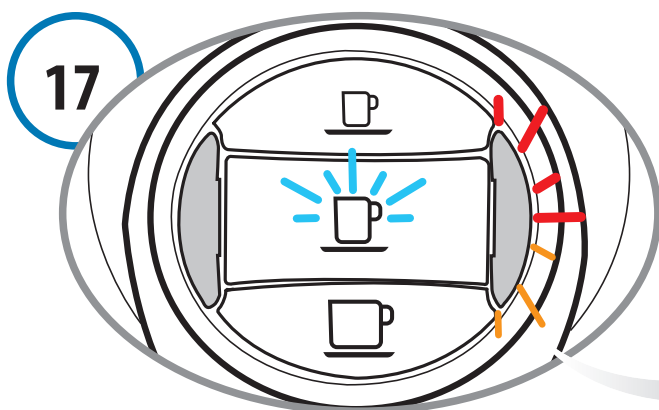

Quando il ciclo di risciacquo è terminato, assieme al tasto **caffè lungo** lampeggia alternata anche la spia **multifunzione** (ROSSO e ARANCIONE). La macchina emette un segnale sonoro.

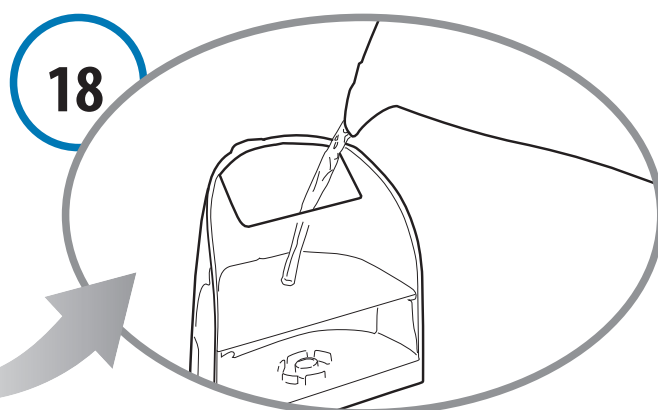

Sciacquare con cura il serbatoio acqua e riempirlo con acqua potabile fresca.

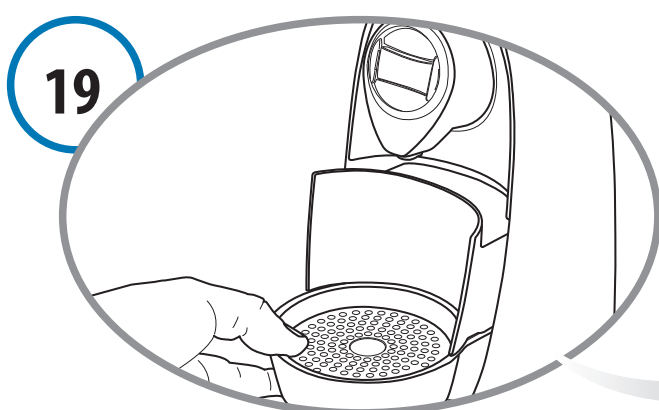

Svuotare e risciacquare il contenitore capsule esauste e la vasca raccogli gocce.

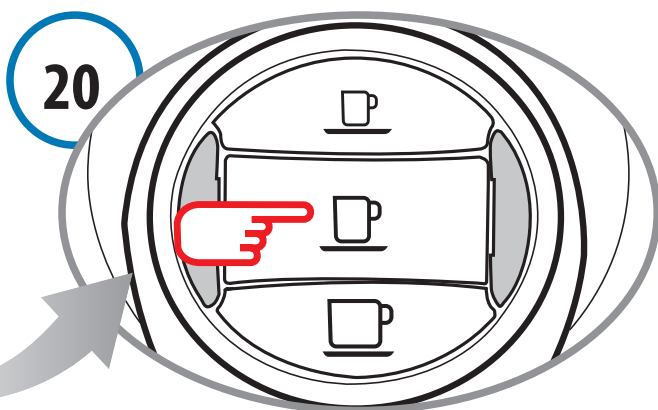



Premere il tasto **caffè lungo** per uscire dal ciclo.



Per pulire la superficie dell'apparecchio utilizzare un panno morbido e un detergente neutro.

PROBLEMA	CAUSA	SOLUZIONE
- Non esce caffè	- Il serbatoio acqua è vuoto, la spia multifunzione è accesa in ROSSO.	- Riempire il serbatoio con acqua fresca. Premere uno dei tasti caffè per effettuare il caricamento del circuito.
- Il caffè non è sufficientemente caldo.	- Tazze / Tazzine fredde. - Macchina con calcare.	- Preriscaldare la tazza / tazzina. - Decalcificare.
- La leva non può essere abbassata.	- Il cassetto capsule esauste è pieno. - Capsula bloccata all'interno della macchina.	- Svuotare il cassetto porta capsule usate. - Rimuovere la capsula usata.

11 Dati tecnici

	Consultare la targhetta dati presente sul fondo della macchina				
P	Max. 15 bar				
	< 70dB A				
	circa 4 kg				
	1,2 litri				
	temperatura ambiente: 10°C ÷ 40°C				
	170 mm		260 mm		320 mm

I materiali e gli oggetti destinati al contatto con prodotti alimentari sono conformi alle prescrizioni del regolamento Europeo 1935/2004.

Introduction

●	Intended use	3
●	Warning symbols.....	3
●	Your Caffitaly System contact	3
●	Safety warnings	4
●	Instructions for use and disposal	5
●	Description of machine components	6

Installation

1	First use or after a long period of disuse	7
2	Turning on the appliance.....	8
3	General operating indications.....	9
4	Adjusting the cup/mug height	11

Dispensing the product

5	Dispensing coffee.....	12
6	Dispensing other beverages	13
7	Programming the quantity of coffee in a cup.....	14

Cleaning and Maintenance

8	Daily maintenance	15
9	Descaling	16

Miscellaneous

10	Troubleshooting.....	20
11	Technical data	20

Dear Customer,

Thank you for having chosen our product and for your confidence in our company. You can savour your favourite hot beverages at any time of the day with our appliance by choosing one of the capsules that Caffitaly offers you. For example: An espresso, a cocoa-flavoured beverage or a tea will be ready in just a few seconds.

Intended use

This appliance is intended to be used in domestic and similar applications such as, for example:

- staff cooking areas in shops, offices and other work environments;
- holiday farms;
- by guests staying at hotels, motels and other residential facilities;
- facilities like bed and breakfasts.

Use only Caffita System capsules. Use of the appliance in any manner other than as directed herein could cause harm to persons and void the guarantee.

The manufacturer will not be responsible for injury or damage resulting from improper use of the appliance.

Warning symbols



CAUTION

This is the safety warning symbol. It is used to call your attention to possible risks of personal injury. Abide by the safety messages provided in order to avoid possible injury or death.



NOTE

This is the symbol used to highlight some actions that will optimise use of the appliance.



Not dishwasher safe



Maintenance tips



This symbol is used to highlight a **WHITE** light indication.



This symbol is used to highlight a **RED** light indication.



This symbol is used to highlight an **ORANGE** light indication.

Your Caffitaly System contact

info@caffita.com

Safety warnings

Carefully read the following instructions! In this way you will avoid the risk of personal injury and damage to the appliance.

- After removing the packaging, make sure that the appliance is intact. If it is damaged, or at the first sign of faulty operation (unusual noises or odours), or if any problem arises inside the appliance, do not use it. Contact an Authorised Service Centre.
- The packaging elements (plastic bags, etc.) must not be left within reach of children as they are potential sources of danger.
- Only use the appliance if the power cord is intact. If the cord is damaged, it should be replaced: contact an Authorised Service Centre. Lethal danger of electric shocks.
- Only use and store the appliance indoors. Make sure the electrical elements, plug and cord are dry. Never submerge the appliance in water. Protect the appliance from sprays and drips. Water and electricity together constitute a risk of electrocution.
- Only connect the appliance to power outlets complying with the requirements of the law. Make sure that the power supply voltage matches the rating shown on the data plate on the bottom of the appliance.
- The surface on which the machine is installed must be level, solid, stable and heat-resistant; a maximum incline of 2° is permitted for the surface on which the appliance is placed.
- Do not allow the appliance to be used by children or persons with impaired mental, physical or sensory faculties or insufficient experience and/or skills, unless they are under the careful supervision and guidance of a person responsible for their safety. Children must be kept under supervision to prevent them from playing with the appliance.
- Do not leave the power cord near hot surfaces, sharp edges or other sharp objects.
- Never place your hands inside the capsule compartment. Danger of injury
- Always close the lever. Never open the lever while the appliance is operating.
- Never remove parts of the appliance. Do not insert objects into the openings. This could cause electric shocks! Any operation that is not described in this instruction manual should only be performed by an Authorised Service Centre!
- Do not pull on the power cord to disconnect it. Remove the plug to avoid damage to the outlet.

- Descale the appliance regularly, following the instructions provided. If you do not, the appliance may be damaged and may become harmful to your health.
- Clean the appliance carefully and regularly. If it is not cleaned, the build-up that forms may be hazardous to your health. Unplug the appliance and allow it to cool before cleaning.
- If you do not expect to use the appliance for a long period of time (leaving on vacation, etc.), unplug it.

Instructions for use and disposal



The appliance has been manufactured using high quality materials that can be reused or recycled. Dispose of the appliance in a suitable waste collection centre.



To rule out any abuse and dangers involved, ensure that the machine cannot be plugged into the mains before delivering it to the scrapping service. To achieve this, unplug the appliance from the outlet and cut the power cord as close as possible to the machine.



Directions for correct disposal of the product according to European Directive 2002/96/EC and Italian Legislative Decree no. 151 dated 25 July 2005. At the end of its useful life, the product should not be disposed of with unsorted household waste. It should be taken to a suitable selective waste collection centre set up by the local authorities or returned to a retailer who provides this service. Separate collection of an electric household appliance avoids a possible negative impact on the environment and health arising from improper disposal and enables the materials it is made of to be recovered so as to achieve significant savings of energy and resources. The crossed-out wheeled bin symbol applied on the product highlights the need to dispose of electric appliances separately. Improper disposal of the product by the user shall be subject to specific administrative sanctions as provided for under current regulations. The packaging is made from recyclable materials. Contact the competent authorities for information regarding local legislation.

Description of machine components

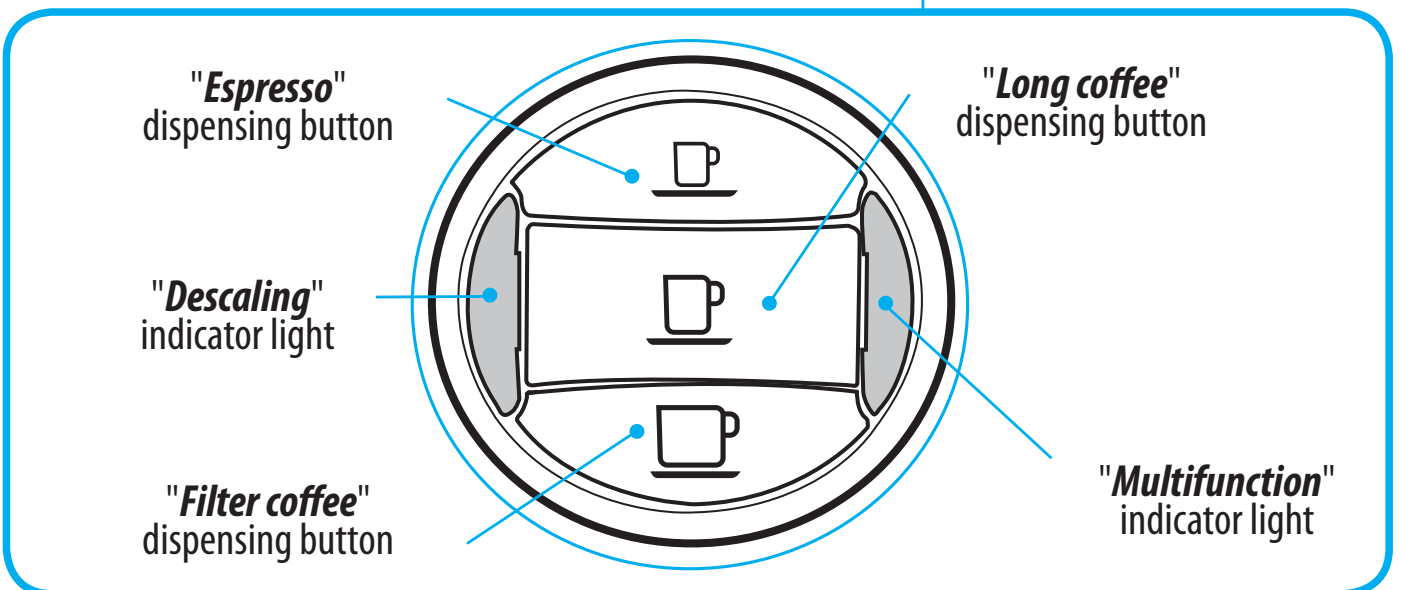
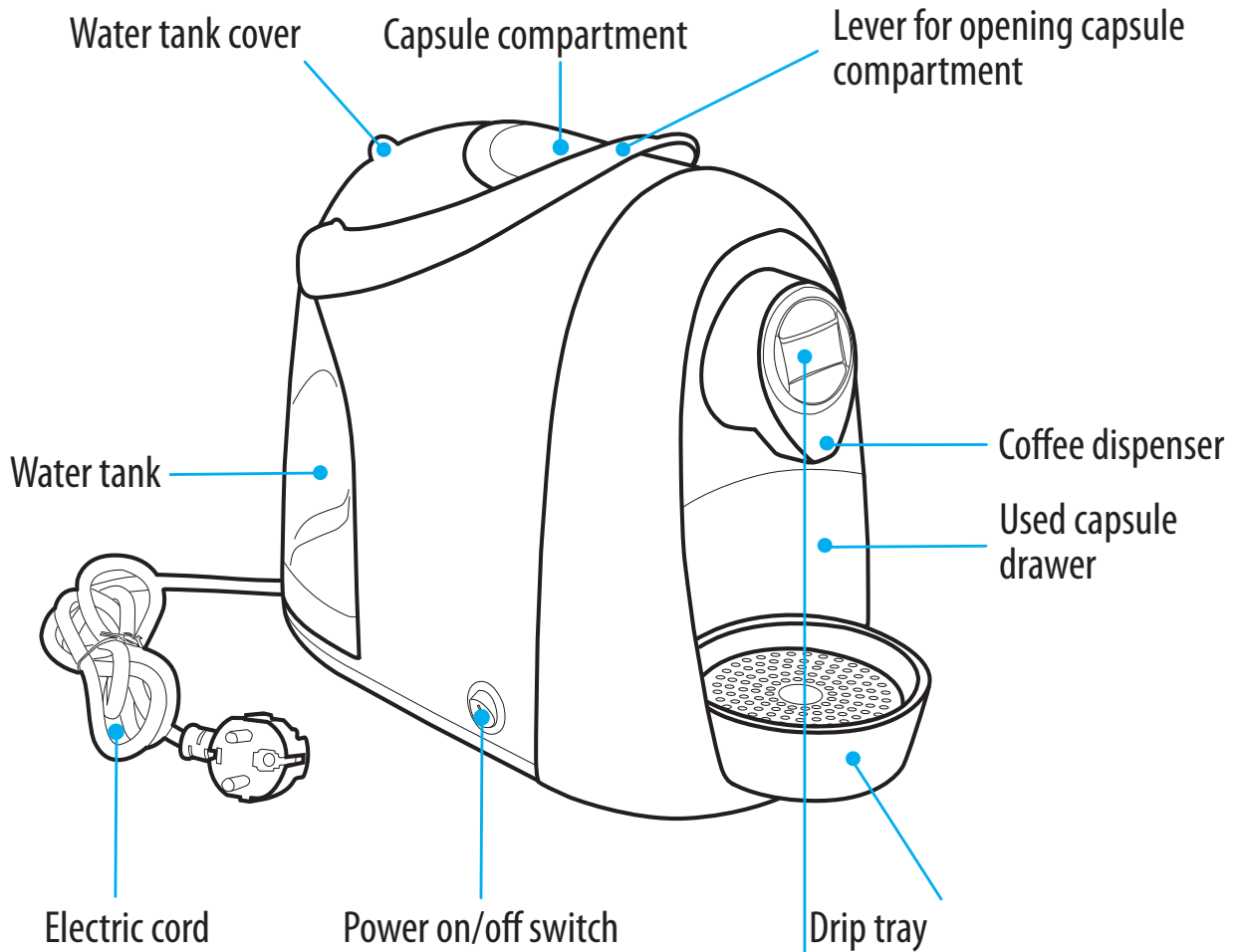

First use or after a long period of disuse 1

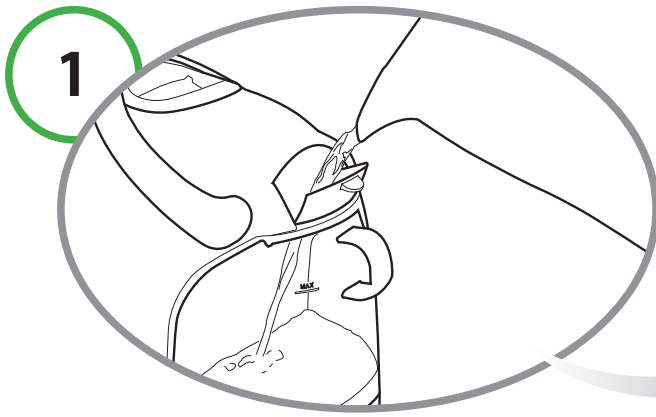

Fill the tank with fresh, still water.

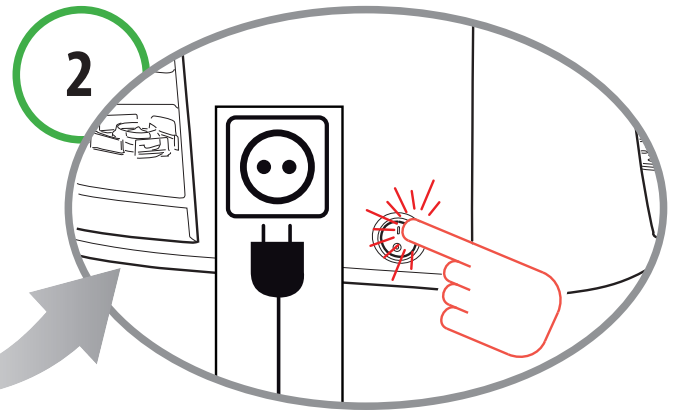

Plug in the appliance and turn it on.

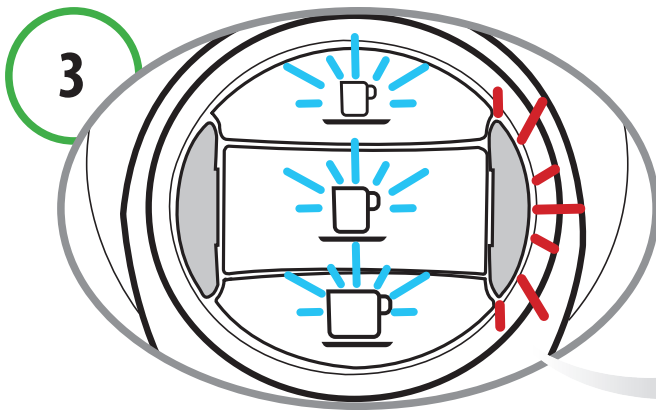

The buttons (**espresso**, **long coffee** and **filter coffee**) and the multifunction indicator light blink at the same time.

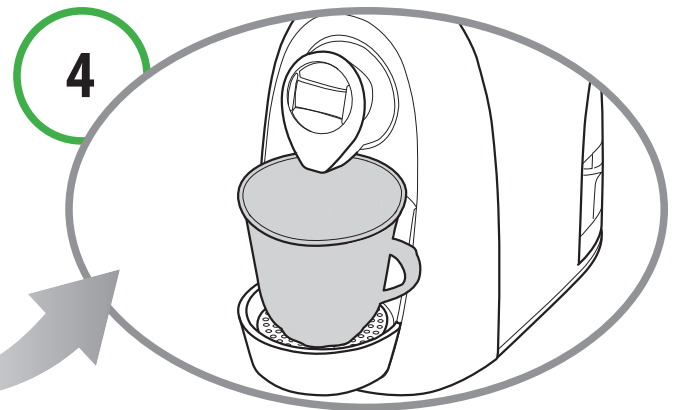

Place a large container under the dispensing spout.

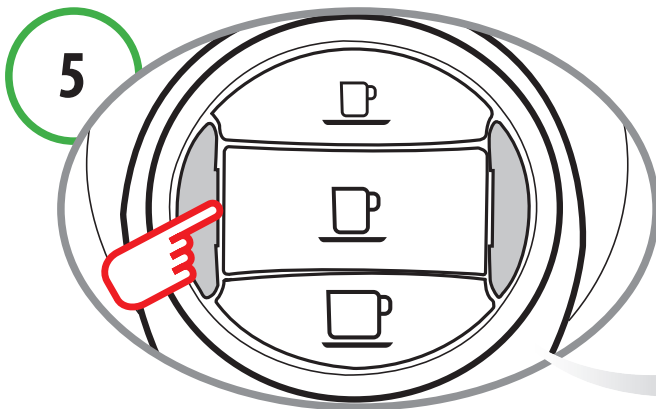

Press one of the coffee buttons (**espresso**, **long coffee** or **filter coffee**). Wait for the machine to complete the priming cycle and fill with water. The **multifunction** indicator light switches off.

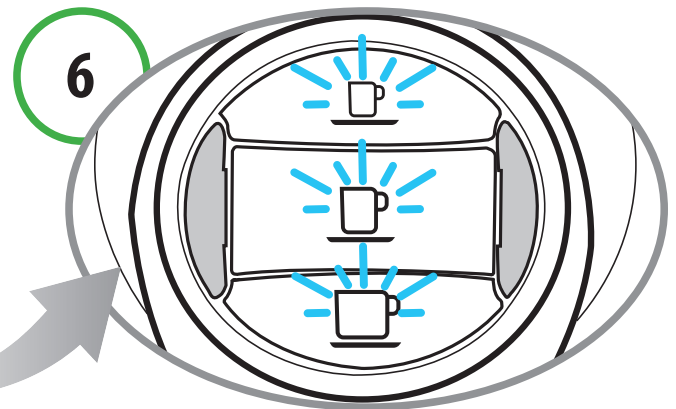

The buttons (**espresso**, **long coffee** and **filter coffee**) blink at the same time; the machine is warming up.



NOTE:

If the coffee buttons and the **multifunction** indicator light continue to blink after the filling procedure has ended, repeat the steps in point 5.

2 Turning on the appliance

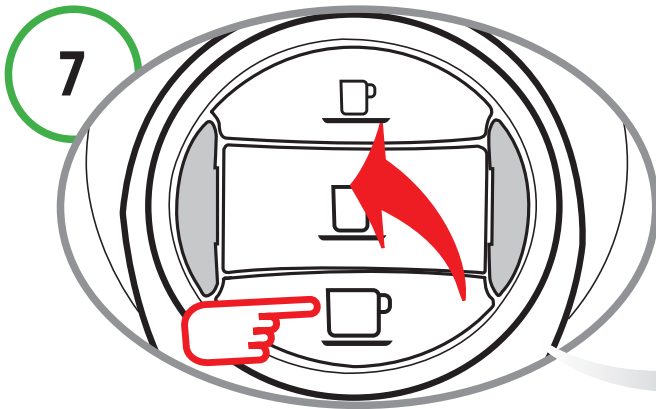

When the buttons (**espresso**, **long coffee**, **filter coffee**) turn on and remain steadily lit, rinse twice by pressing the **filter coffee** button.
Wait for the machine to complete the rinse cycle.

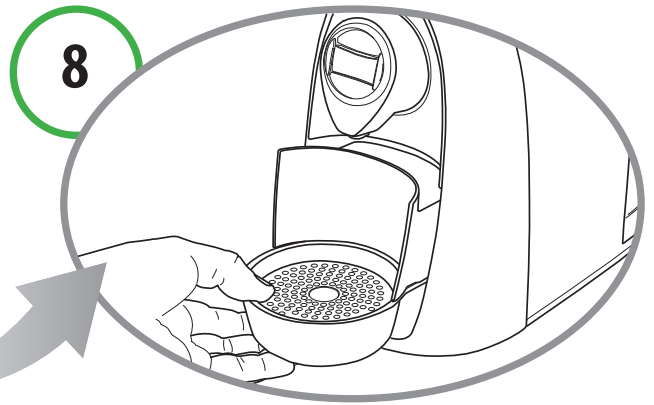

At the end of this operation, empty out the water from the used capsule drawer.

2 Turning on the appliance

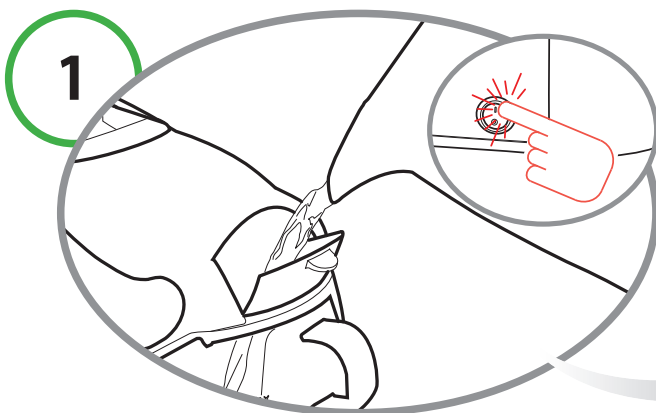

Fill the tank with fresh, still water. Turning on the appliance

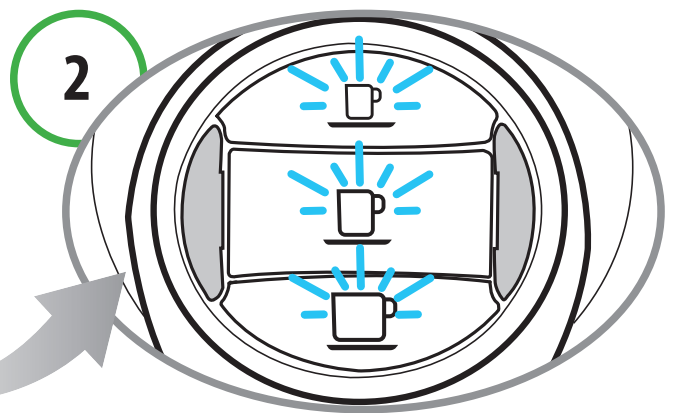

The buttons (**espresso**, **long coffee** and **filter coffee**) blink at the same time; the machine is warming up. When the buttons remain steadily lit, the appliance is ready for operation.

Descaling signal

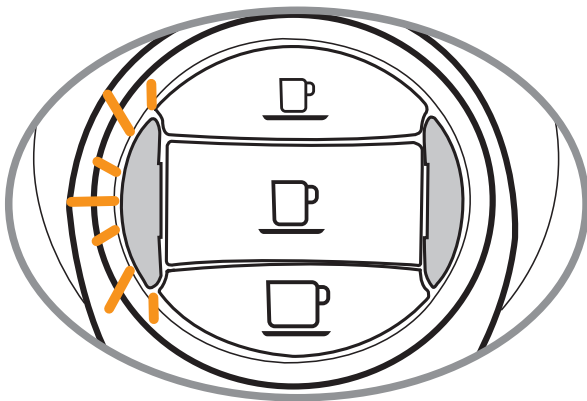

When the **descaling** indicator light blinks ORANGE and the machine emits 3 beeps, it is recommended to perform the descaling cycle (see Ch. 9).

Heating

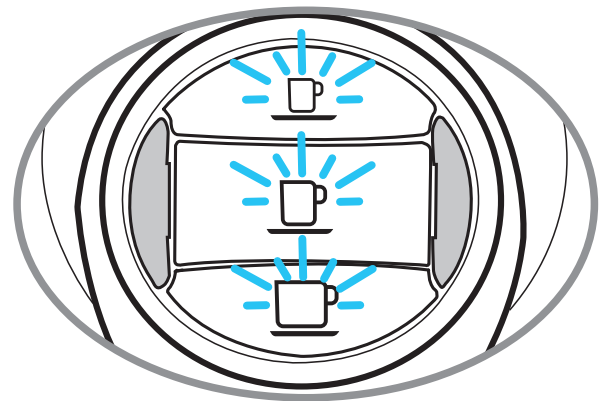

The buttons (**espresso**, **long coffee** and **filter coffee**) blink at the same time.

When the water runs out during operation

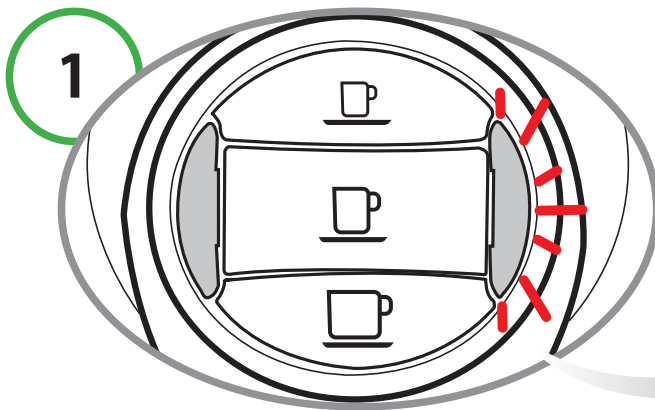

The water tank is empty when the **multifunction** indicator light blinks in RED and the appliance emits 3 beeps followed by a single intermittent beep.

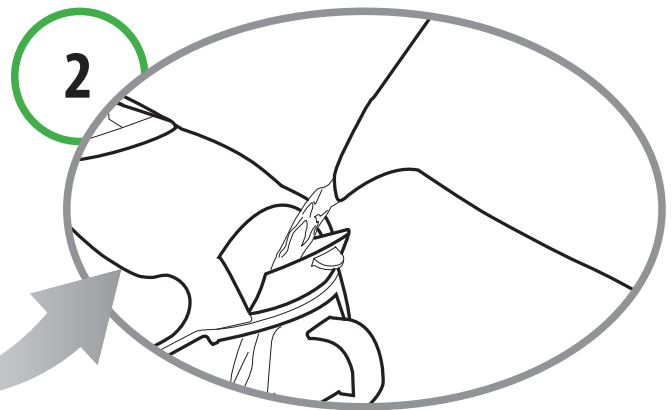

Fill the tank with fresh, still water.

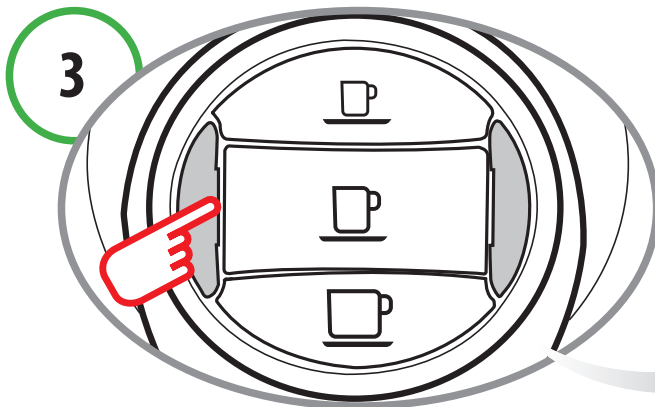

Press one of the coffee buttons (**espresso**, **long coffee** or **filter coffee**). Wait for the machine to complete the priming cycle and fill with water.

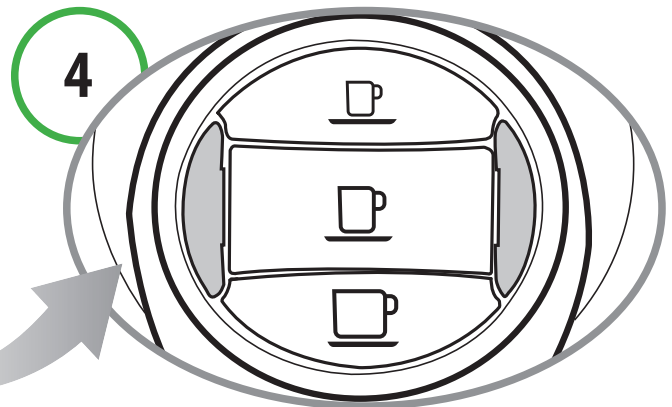

When the buttons remain steadily lit, the appliance is ready for operation.

If the lever is raised



CAUTION!
Raising the lever incorrectly while dispensing a product may cause brief splashes of hot water.
Danger of scalding!

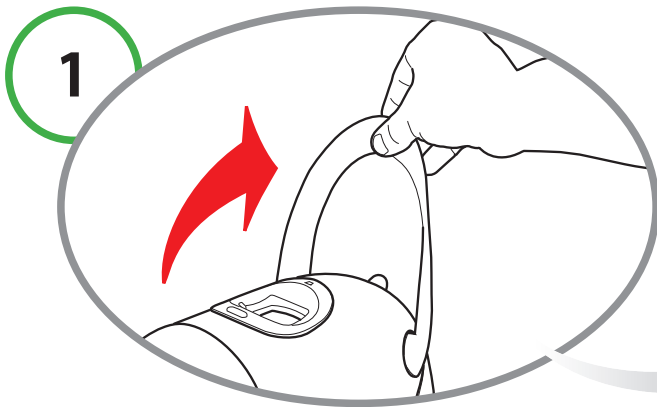

If the lever is raised while a product is being dispensed.

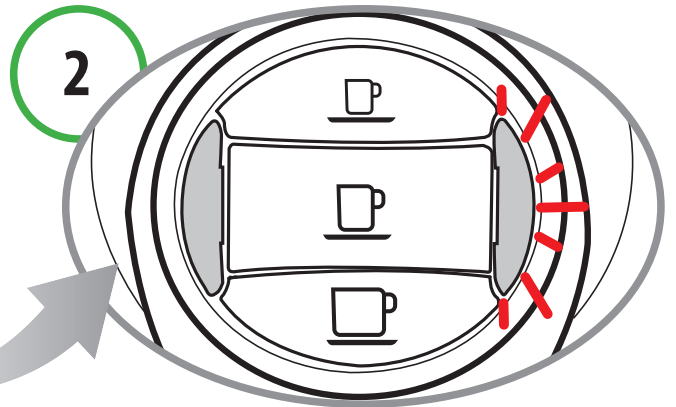

The **multifunction** indicator light blinks in RED and an intermittent beep sounds. The appliance will immediately stop dispensing.



Close the lever.

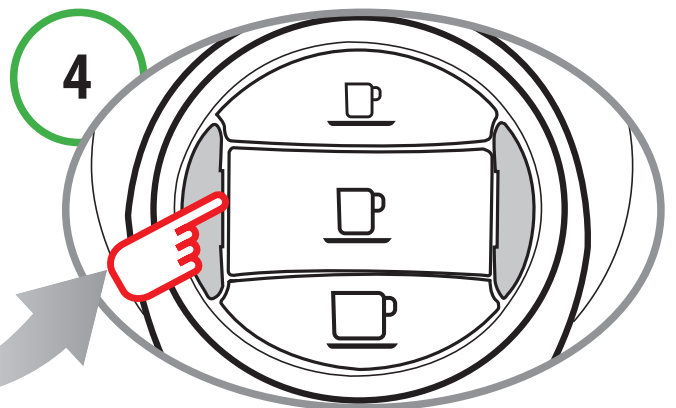

Press a button to reset the alarm.
The appliance is ready for use.

Adjusting the cup/mug height 4

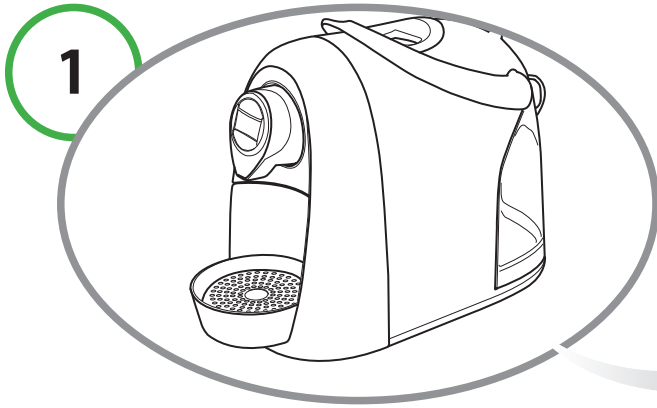

The appliance can be adjusted for the use of mugs or espresso cups.

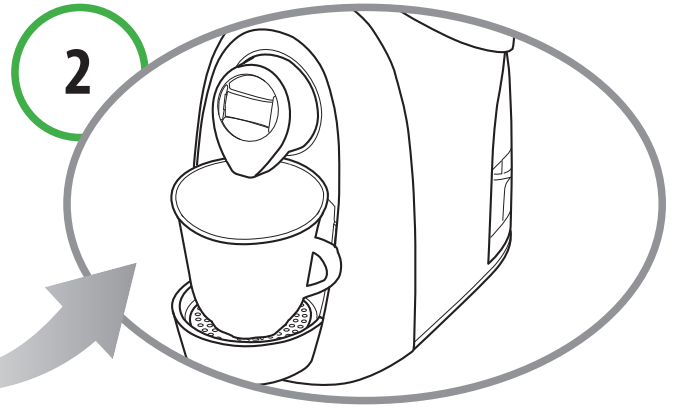

The appliance is initially set for the use of large cups or mugs.

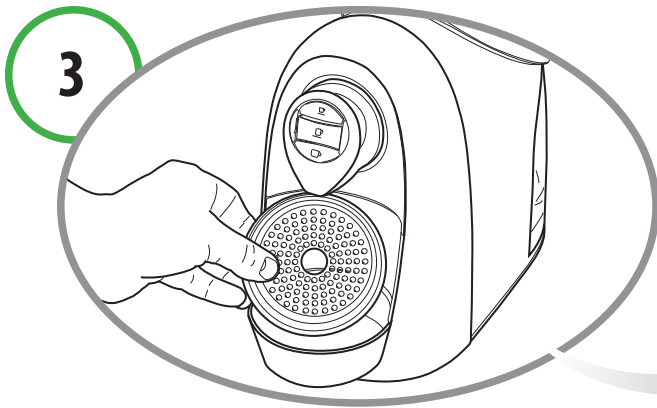

In order to use espresso cups, you must lift and turn the grid on top of the drip tray.

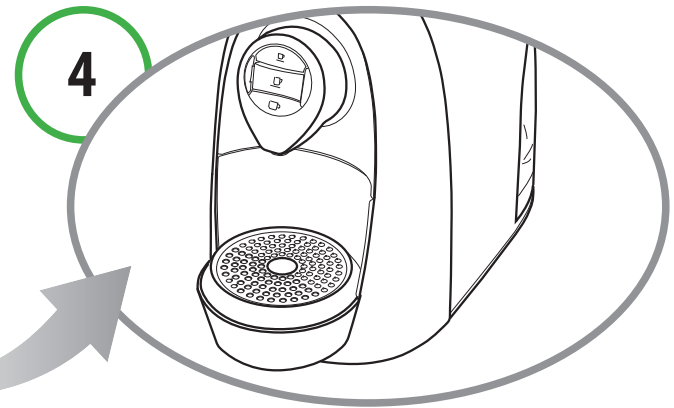

The grid must be positioned over the turned drip tray.

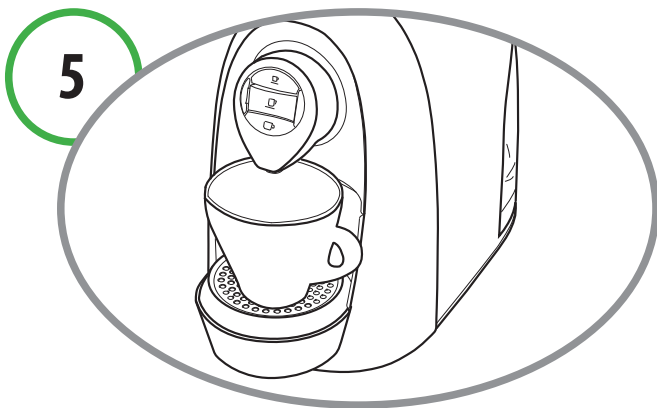

In this way you can obtain the best results when using small espresso cups.

5 Dispensing coffee

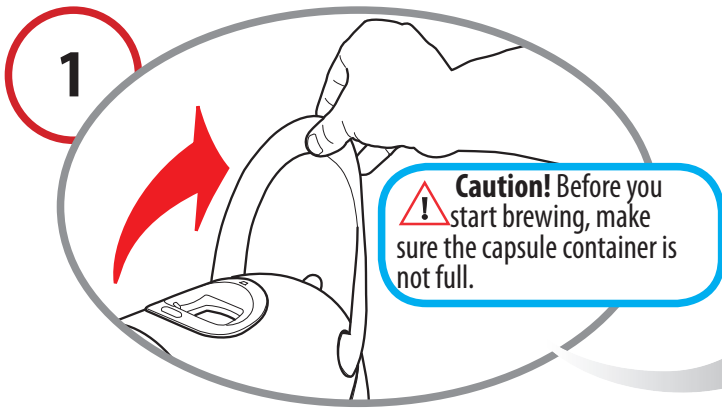

Raise the lever to open the capsule compartment.

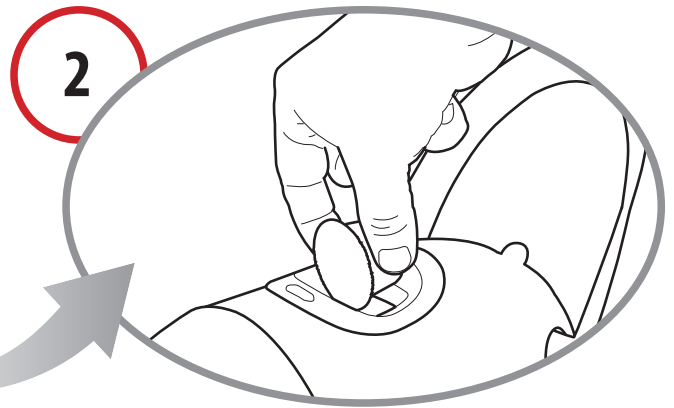

Insert the capsule, pressing it gently into place.

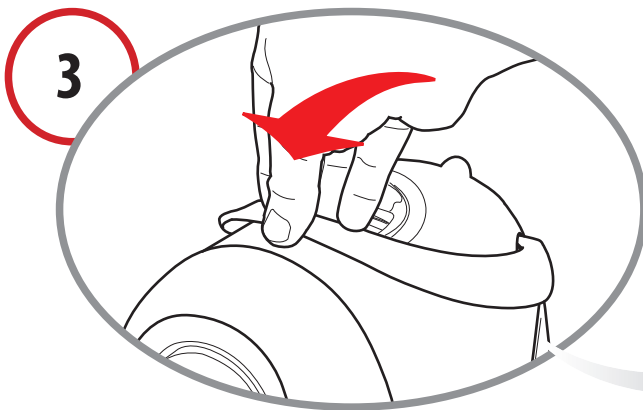

Close the lever firmly.

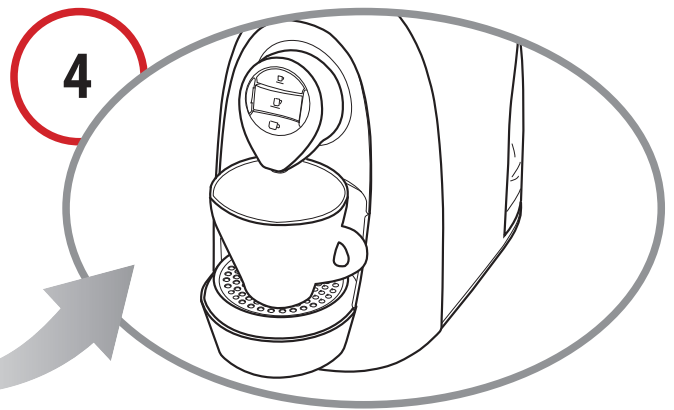

Place a cup or mug under the coffee dispensing spout.

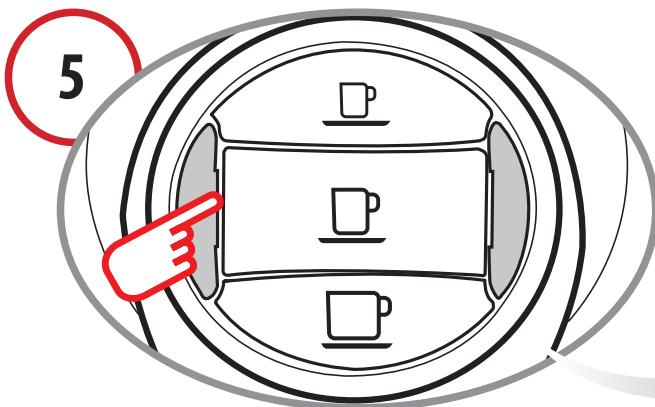

Press the desired coffee button only once.

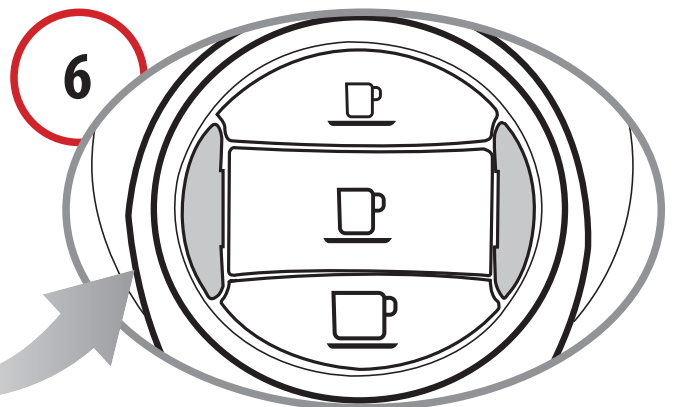

The selected coffee button will blink. The appliance will stop dispensing on reaching the programmed quantity and emit a beep.

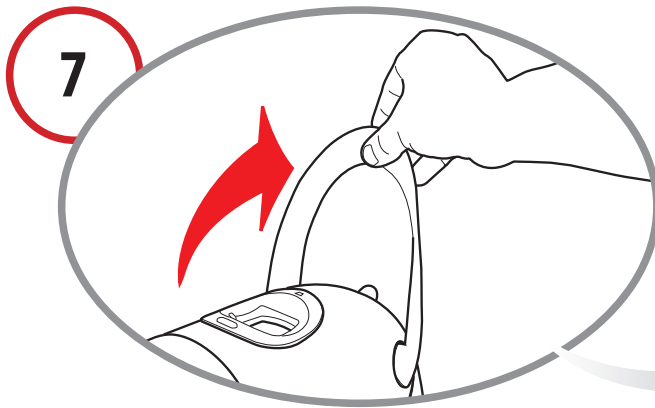

Raise the lever to eject the used capsule into the drawer.

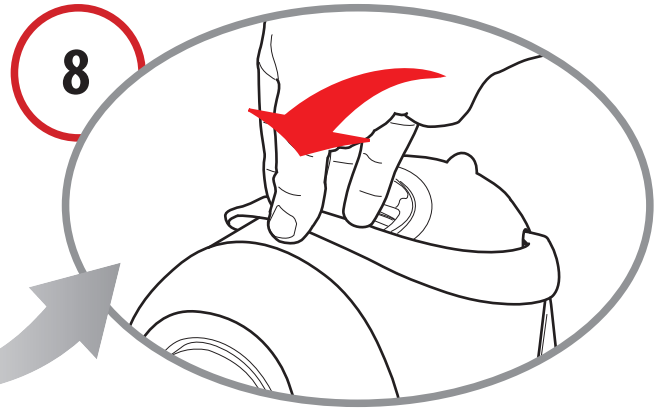

Close the lever.



NOTE:

The quantity of coffee dispensed can be **reprogrammed** according to personal taste, and in accordance with the size of the cup or mug used. Please refer to chapter 7 for reprogramming instructions.

6 Dispensing other beverages

Capsules for preparing beverages such as **tea, chamomile tea, filter coffee, etc. are available.** For their use, proceed as directed in the previous chapter; on reaching step 5, press "**Filter coffee**".

To prepare beverages using **barley capsules, cocoa drinks, etc.**, proceed as directed in the previous chapter; on reaching step 5 press the "**Espresso**" or "**Long coffee**" button, depending on the desired quantity.



NOTE:

Traces of product just dispensed may remain in the circuit of the machine. When switching from one product to another, in order to fully enjoy the flavour of the beverage we suggest rinsing the machine by pressing the coffee button as if to dispense a coffee without inserting a capsule.

7 Programming the quantity of coffee in a cup

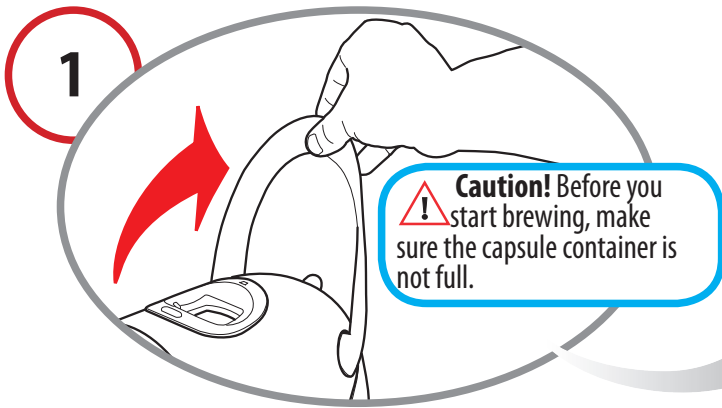

Raise the lever to open the capsule compartment.

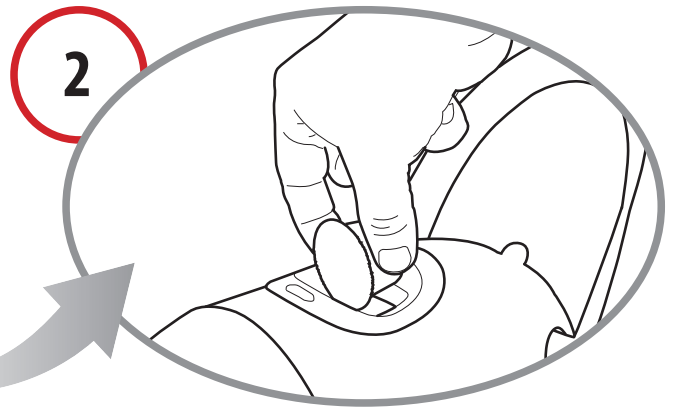

Insert the capsule, pressing it gently into place.

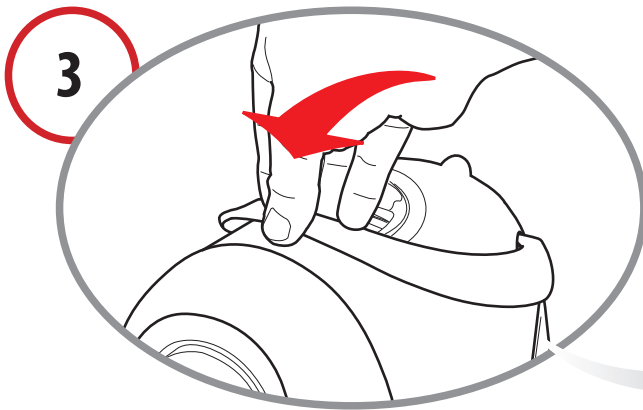

Close the lever firmly.

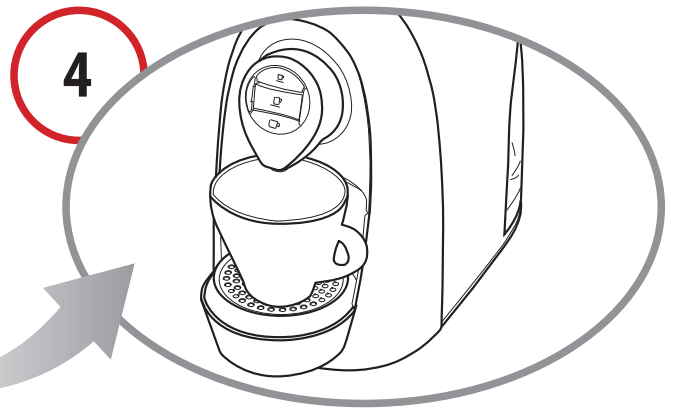

Place a cup or mug under the coffee dispensing spout.

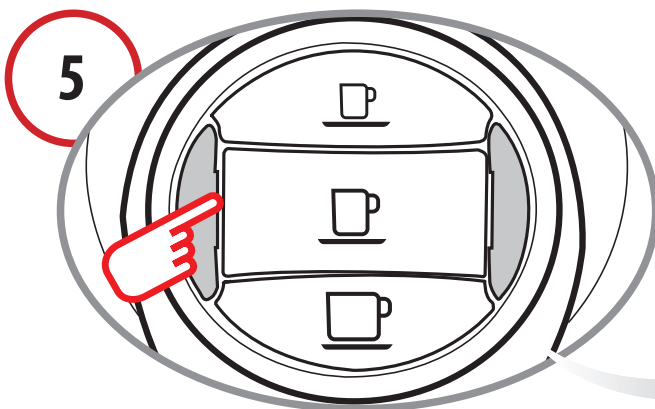

Press the desired coffee button and **keep it pressed down**.

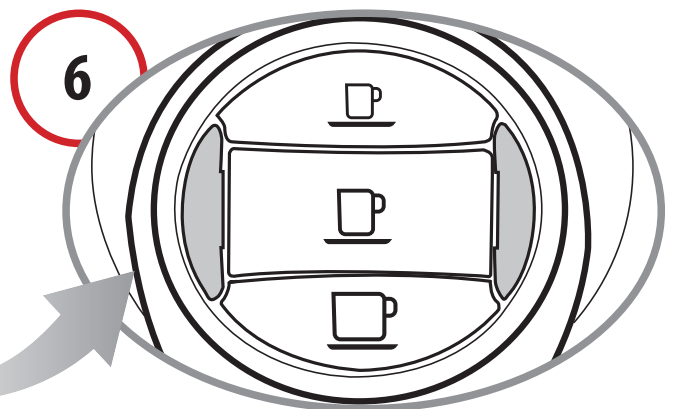

On reaching the desired amount of coffee in a cup, release the button. Now the button is programmed. To reprogram the button or program another button repeat the above steps.
The quantity of coffee dispensed can be programmed up to a maximum of 250 ml.

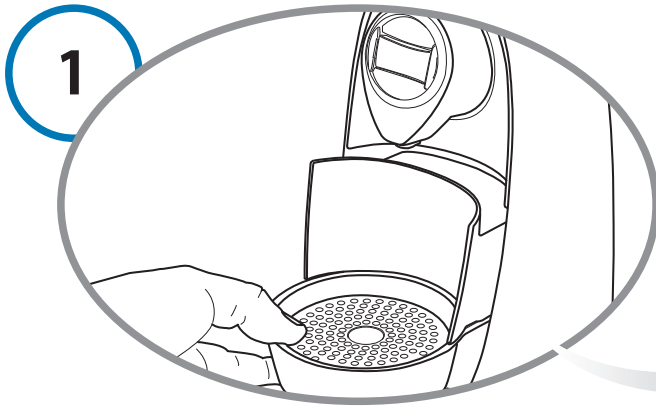

Remove the drip tray and used capsule drawer.

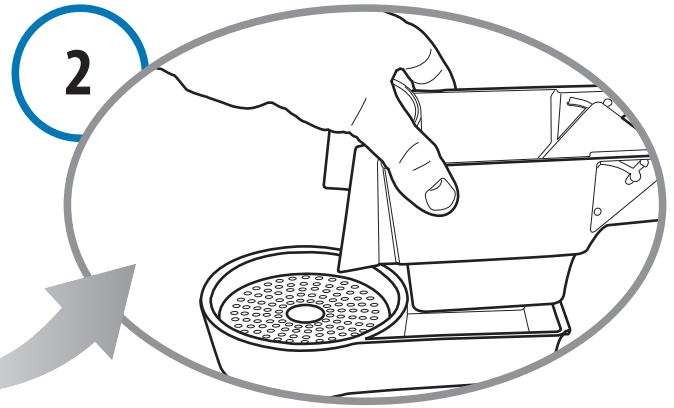

Lift the capsule drawer; empty and rinse it.

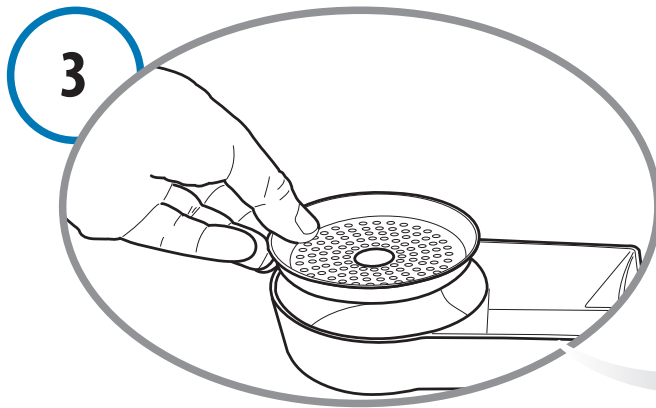

Remove the grid. Empty the drip tray and rinse it out with fresh water.

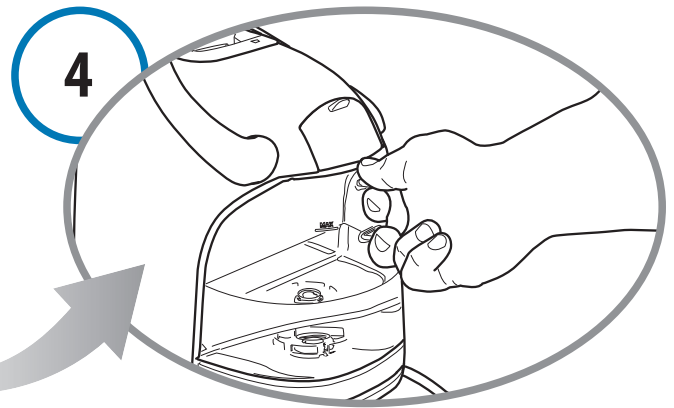

Remove the water tank. Empty and rinse out the tank. The water tank is NOT dishwasher safe.



Use a soft cloth and a neutral detergent to clean the surfaces of the appliance. Do not spray the appliance with jets of water when cleaning.



The plastic parts of the appliance are not dishwasher safe.

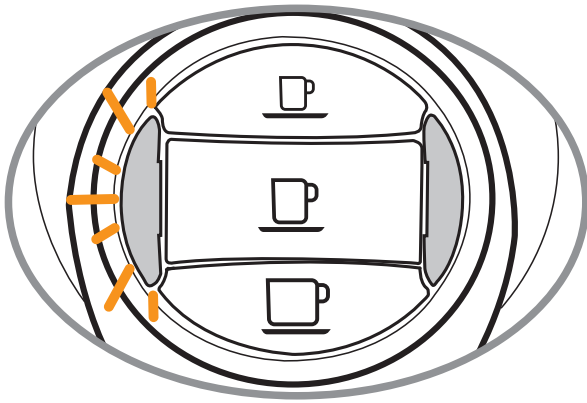

The machine features an advanced program that monitors how much water is used to dispense beverages. This measurement provides the user with indications as to when the machine needs to be descaled. Specific indications are given in chapter 3.

When the **descaling** indicator light blinks ORANGE and the machine emits 3 beeps, it is recommended to perform the descaling cycle (see Ch. 9).



CAREFULLY read the directions for use on the package of the descaling agent. Avoid contact with eyes, skin and machine surfaces. Switch the appliance off during descaling, and do not lift the lever.

A person must be present during the operation.

Do not use vinegar: it could damage your appliance!

It is advisable to use the Caffita System descaling agent. It has been studied to comply with the technical characteristics of the appliance, in full observance of consumer safety. The descaling agent must be disposed of in compliance with manufacturer instructions and/or with current regulations in force in the country where the appliance is used.

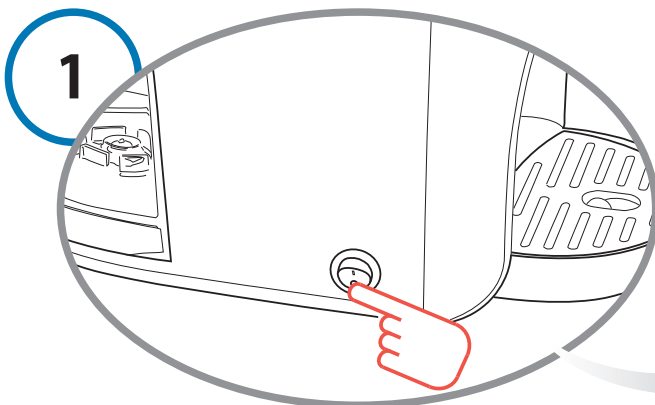

Turn off the machine.

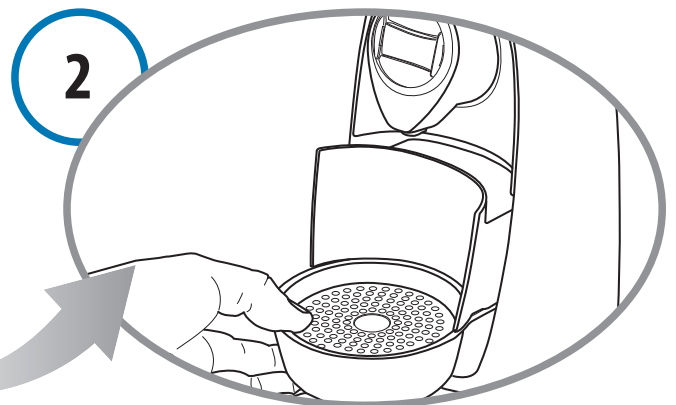

Empty and rinse out the used capsule drawer and drip tray.

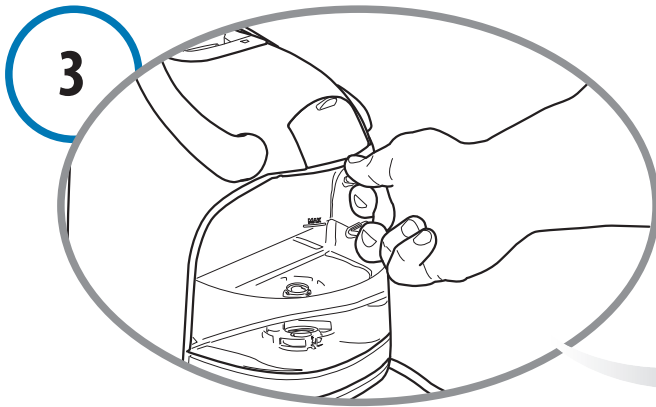

Remove and empty the water tank.

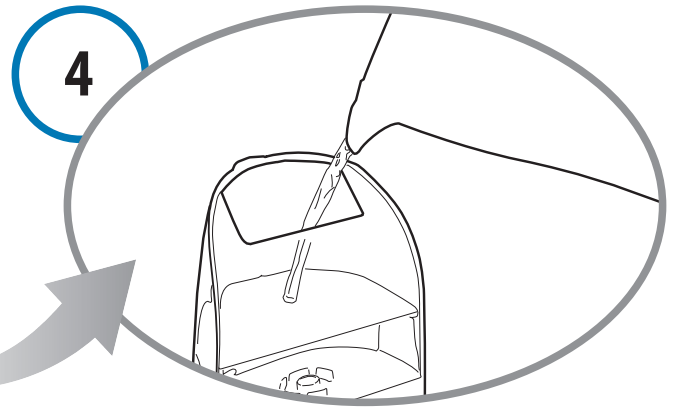

Mix the descaling agent with water as instructed on the package and pour the solution into the tank.

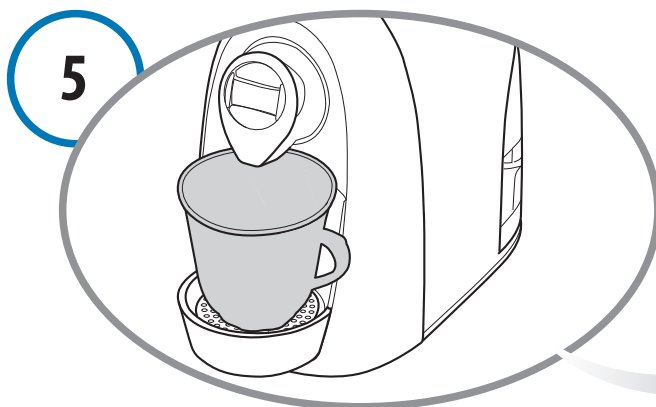

Place a container (at least 250 ml) under the coffee dispensing spout.

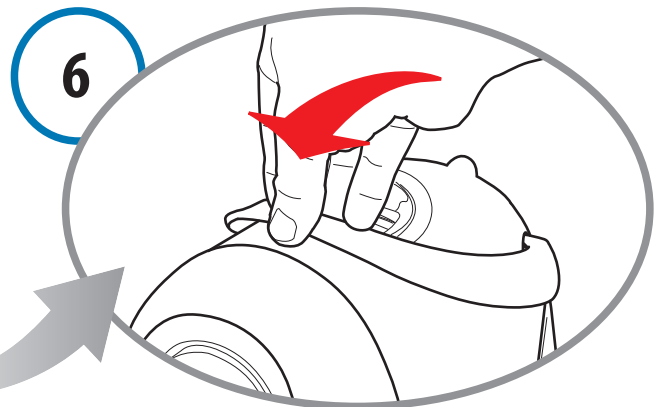

Make sure the lever is lowered.

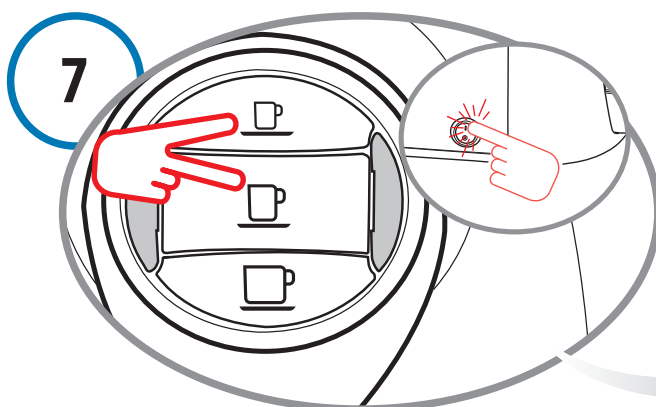

Keep the buttons pressed down (**espresso** and **long coffee**) and at the same time turn on the machine by pressing the power on/off switch.

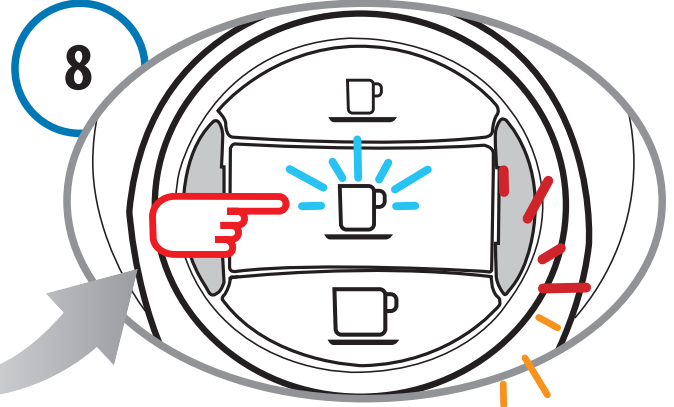

As well as the **long coffee** button, the **multi-function** indicator light also blinks alternately (RED and ORANGE). Press the **long coffee** button to start the descaling cycle.

9 Descaling

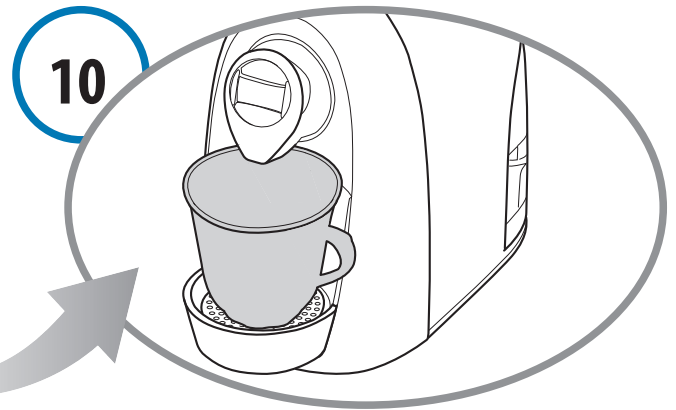
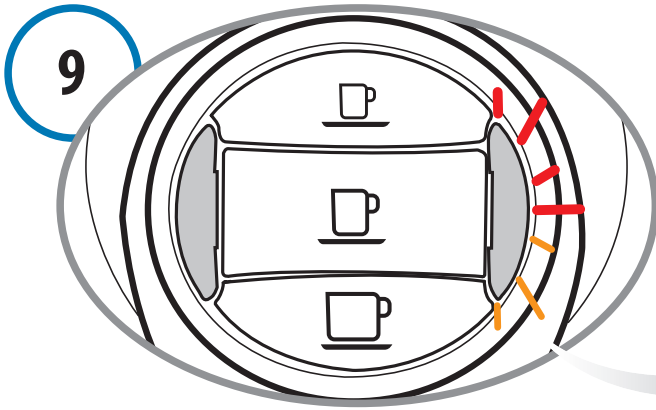

The appliance dispenses the descaling solution at intervals (**5 doses with a 10 minute pause between each one, for a total duration of about 45 minutes**). During this step, **when the buttons must not be pressed**, the **multifunction** indicator light blinks alternately (RED and ORANGE).

If the container fills up, empty it out.

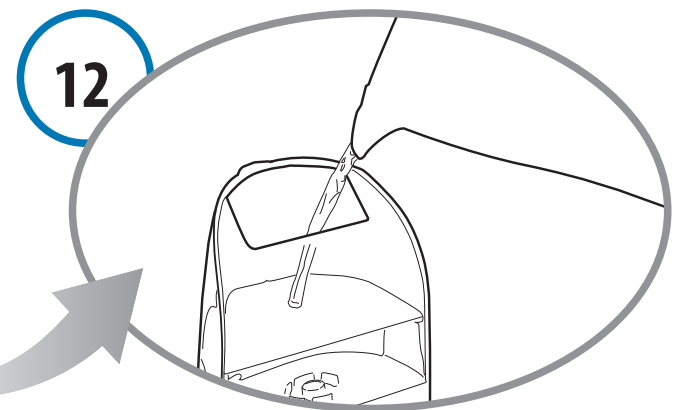
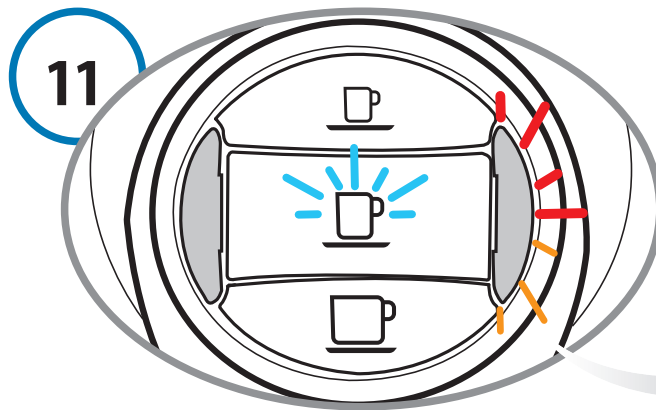

When the cycle is complete, as well as the **long coffee** button, the **multifunction** indicator light also blinks alternately (RED and ORANGE).

Carefully rinse out the water tank and fill it with fresh drinking water.

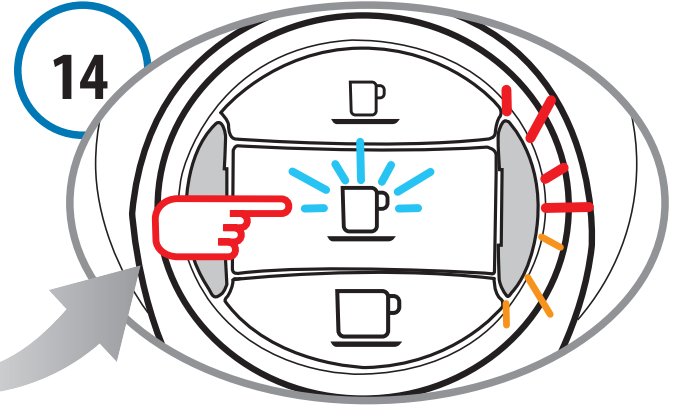
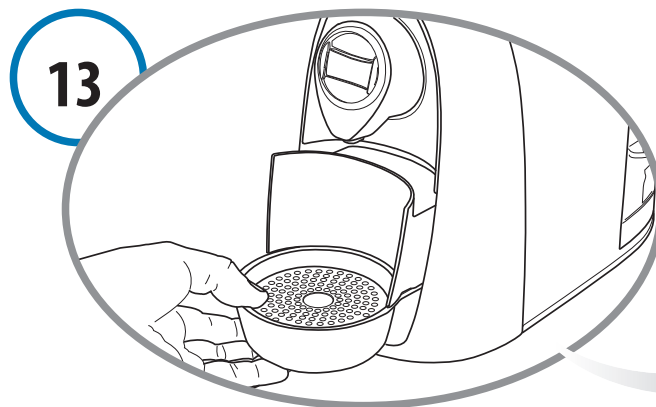

Empty and rinse out the used capsule drawer and drip tray.

As well as the **long coffee** button, the **multifunction** indicator light also blinks alternately (RED and ORANGE). Press the **long coffee** button to start the rinse cycle.

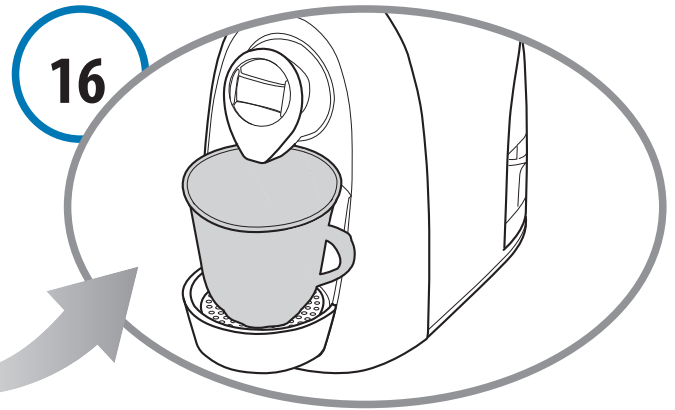
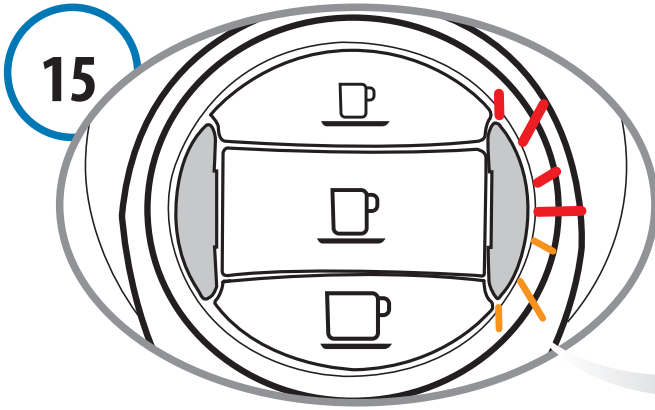

Rinse water will be run through the machine. During this step the **multifunction** indicator light blinks alternately (ORANGE and RED twice in a row).

If the container fills up, empty it out.

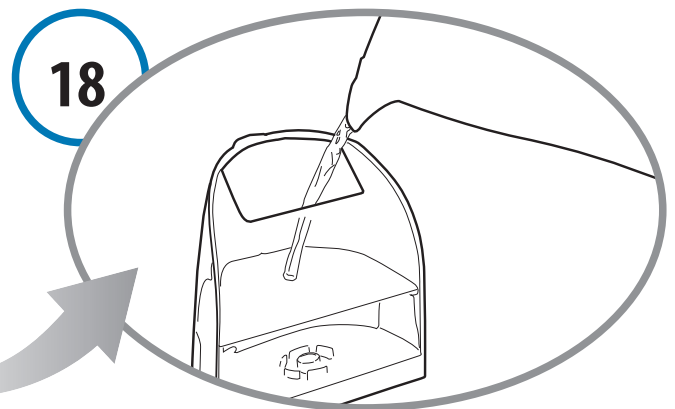
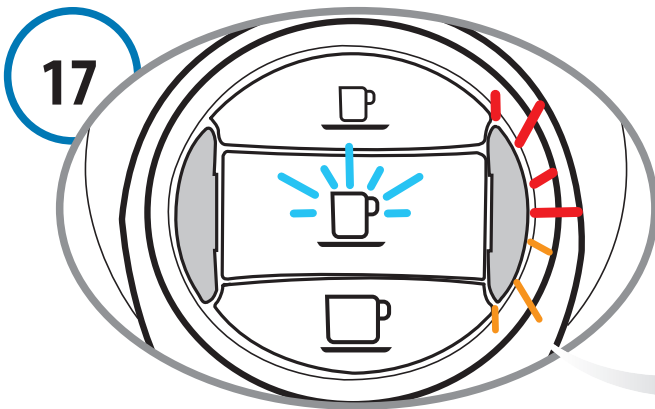

When the rinse cycle is complete, in addition to the **long coffee** button, the **multifunction** indicator light also blinks alternately (RED and ORANGE). The machine will emit a beep.

Carefully rinse out the water tank and fill it with fresh drinking water.

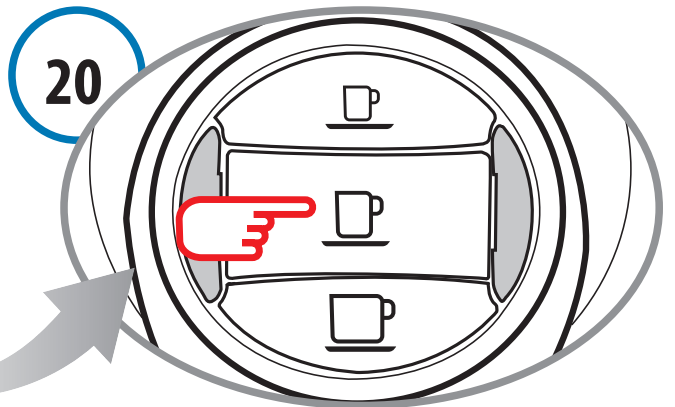
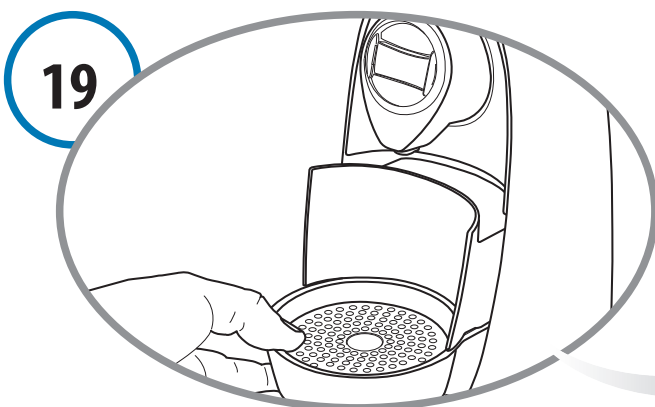

Empty and rinse out the used capsule drawer and drip tray.









Press the **long coffee** button to quit the cycle.

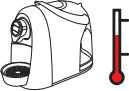

Use a soft cloth and a neutral detergent to clean the surfaces of the appliance.

PROBLEM	CAUSE	SOLUTION
- No coffee is brewed.	- The water tank is empty, the multifunction indicator light is lit in RED.	- Fill the tank with fresh water. Press one of the coffee buttons to fill the circuit.
- The coffee is not hot enough.	- Cold cups / mugs. - Scale build-up in machine.	- Preheat cup / mug. - Descale.
- The lever cannot be lowered.	- The used capsule drawer is full. - Capsule stuck inside the machine.	- Empty out the used capsule drawer. - Remove the used capsule.

11 Technical data

	See the data plate on the bottom of the machine		
P	Max. 15 bar		
	< 70dB A		
	about 4 kg		
	1,2 litres		
	ambient temperature: 10°C ÷ 40°C		
	170 mm	 260 mm	 320 mm

The materials and objects in contact with food products comply with the requirements of European Regulation 1935/2004.

Introduction

● Usage conforme à la destination	3
● Symboles d'avertissement	3
● Votre contact Caffitaly System.....	3
● Avertissements de sécurité	4
● Instructions concernant l'emploi et l'élimination	5
● Description des composants de la machine	6

Installation

1 Lors de la première utilisation ou après une longue période d'inactivité	7
2 Allumer l'appareil	8
3 Signaux généraux de fonctionnement	9
4 Réglage hauteur grande tasse/petite tasse	11

Distribution d'un produit

5 Distribution de café	12
6 Préparation d'autres boissons	13
7 Programmation de la quantité de café dans la tasse	14

Nettoyage et entretien

8 Nettoyage quotidien	15
9 Détartrage	16

Autres

10 Résolution des problèmes.....	20
11 Données techniques.....	20

Cher client,

nous vous remercions d'avoir choisi notre produit et pour la confiance que vous nous avez accordée. Grâce à notre machine, vous pourrez choisir parmi les différentes capsules proposées par Caffitaly et déguster vos boissons chaudes préférées à n'importe quel moment de la journée. Par exemple : Un café expresso, une boisson au cacao ou un thé seront prêts en quelques secondes.

Usage conforme à la destination

Cet appareil est destiné à être utilisé dans des conditions domestiques et similaires, par exemple :

- espace cuisine réservé au personnel dans des bureaux et autres milieux professionnels ;
- agritourisme ;
- hôtels, motels et autres établissements du type résidentiel ;
- structures du type « bed and breakfast ».

N'utiliser que des capsules spécifiques pour le système Caffitaly. N'importe quelle autre utilisation non prévue par ces instructions peut causer des blessures aux personnes et faire cesser la garantie. Le constructeur n'est pas responsable des dommages venant d'un usage impropre de l'appareil.

Symboles d'avertissement

ATTENTION



Ce symbole indique un avertissement de sécurité. Il est utilisé pour attirer l'attention sur des risques possibles de blessures personnelles. Se rapporter aux messages de sécurité indiqués afin d'éviter toute blessure grave, voire mortelle.



NOTA BENE

Ce symbole est utilisé pour souligner certaines actions qui améliorent l'utilisation de la machine.



Non lavables en lave-vaisselle



Conseils de nettoyage



Ce symbole est utilisé pour souligner un signal lumineux **BLANC**.



Ce symbole est utilisé pour souligner un signal lumineux **ROUGE**.



Ce symbole est utilisé pour souligner un signal lumineux **ORANGE**.

Votre contact Caffitaly

info@caffita.com

Avertissements de sécurité

Lire attentivement les instructions suivantes ! Leur respect permet d'éviter les accidents et d'endommager l'appareil.

- Lors du déballage, s'assurer de l'intégrité de l'appareil. En cas de dommages, ou au premier signe de défectuosité (bruits ou odeurs insolites), ou pour tout problème à l'intérieur de l'appareil, ne pas utiliser ce dernier mais s'adresser à un Centre d'Assistance Agréé.
- Ne pas laisser les éléments de l'emballage (sachets en plastique, etc.) à la portée des enfants du fait qu'ils constituent une sources de danger.
- N'utiliser l'appareil que si le câble d'alimentation est intact. Pour le remplacement du câble, si endommagé, s'adresser exclusivement à un Centre d'assistance Agréé. Danger de mort par choc électrique.
- Conserver et utiliser l'appareil seulement à l'intérieur. S'assurer que les éléments électriques, fiches et câbles sont secs. Ne jamais plonger l'appareil dans l'eau. Protéger l'appareil contre les éclaboussures ou les gouttes. L'association électricité-eau engendre le danger de mort par choc électrique.
- Ne brancher l'appareil que sur des prises de courant conformes aux normes. S'assurer que la tension du réseau électrique correspond à celle reportée sur la plaquette des données apposée sur le fond de l'appareil.
- La surface d'installation de la machine doit être plane, solide, fixe et résistante à la chaleur ; l'inclinaison de la surface d'appui ne doit pas dépasser 2°.
- Ne pas permettre l'utilisation de l'appareil de la part de personnes (y compris les enfants) ayant de faibles capacités psychophysiques ou sensorielles, aux expériences et aux connaissances insuffisantes, à moins qu'elles ne soient sous la supervision attentive d'une personne responsable de leur sécurité ou formées par cette personne. Surveiller les enfants et s'assurer qu'ils ne jouent pas avec l'appareil !
- Ne pas laisser le câble d'alimentation à proximité de surfaces chaudes, d'arêtes ou d'objets tranchants.
- Ne jamais mettre les mains dans le logement porte-capsules. Danger de blessures.
- Toujours refermer la poignée. Ne jamais ouvrir la poignée lorsque l'appareil est en marche.
- Ne jamais enlever des parties de la machine. N'introduire aucun objet dans les ouvertures. Cela pourrait causer des chocs électriques ! Toute intervention non expliquée dans ces instructions ne doit être effectuée que par un Centre d'assistance agréé !
- Ne pas débrancher le câble d'alimentation en tirant dessus mais extraire la fiche pour ne pas endommager la prise.

- Effectuer le détartrage par intervalles réguliers, comme les instructions l'indiquent. Autrement, l'appareil pourrait être endommagé et nuire à la santé.
- Nettoyer scrupuleusement et régulièrement l'appareil. Le dépôt se créant en cas de défaut de nettoyage pourrait nuire à la santé. Débrancher l'appareil et le laisser refroidir avant de le nettoyer.
- Si l'on prévoit de ne pas utiliser l'appareil pendant de longues périodes (vacances, etc.), débrancher la fiche de la prise.

Instructions concernant l'emploi et l'élimination



L'appareil se compose de matériaux de haute qualité pouvant être réutilisés ou recyclés. Éliminer l'appareil dans une décharge spécialisée.



Pour éviter tout abus ou danger, faire en sorte que la machine ne puisse pas être reliée au réseau électrique avant de la remettre au service de mise au rebut. Pour ce faire, débrancher la fiche de l'appareil de la prise de courant et couper le câble d'alimentation le plus près possible de la machine.



Avertissements pour l'élimination correcte du produit conformément à la directive européenne 2002/96/EC et du décret législatif italien n° 151 du 25 juillet 2005. A la fin de sa durée de vie, le produit ne doit pas être éliminé avec les déchets urbains. Il peut être remis aux centres de collecte sélective prévus par les administrations municipales, ou bien auprès des revendeurs fournissant ce service. L'élimination séparée d'un électroménager permet d'éviter des conséquences néfastes sur l'environnement et la santé pouvant dériver de son élimination inappropriée. Elle permet en outre de récupérer les matériaux dont il se compose afin d'économiser beaucoup d'énergie et de ressources. Pour souligner l'obligation d'éliminer séparément les électroménagers, la marque du conteneur barré est placée sur le produit. L'élimination abusive du produit de la part de son utilisateur implique l'application de sanctions administratives prévues par la réglementation en vigueur. L'emballage est en matériau recyclable. S'adresser aux autorités compétentes concernant la réglementation locale.

Description des composants de la machine

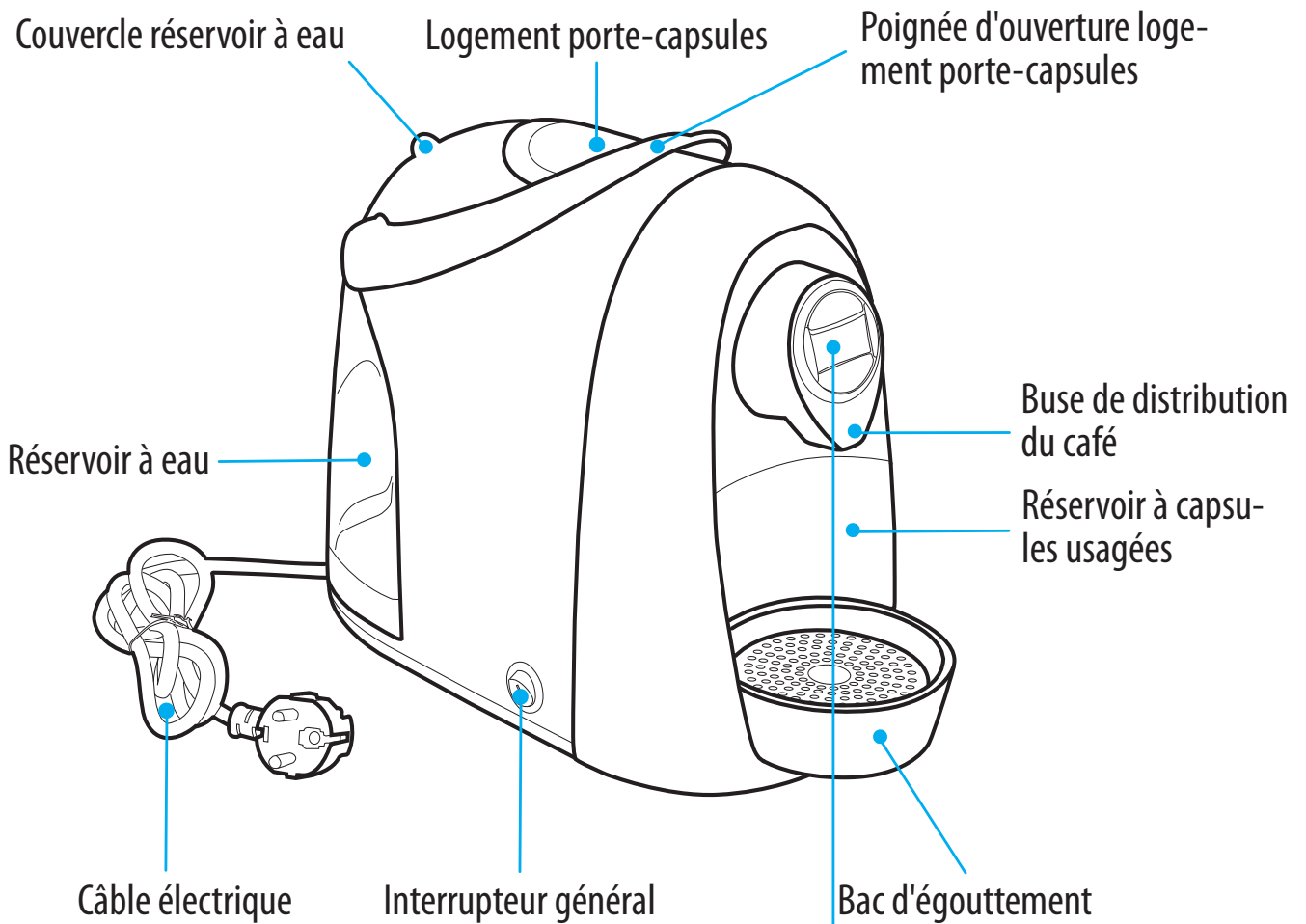

Touche distribution
« **Café expresso** »

Touche distribution
« **Café allongé** »

Voyant
« **Détartrage** »

Touche distribution
« **Café filtre** »

Voyant
« **Multifonction** »

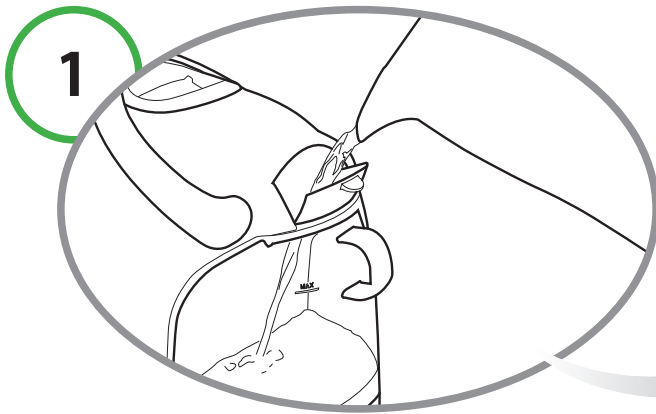

Remplir le réservoir avec de l'eau fraîche (non pétillante).

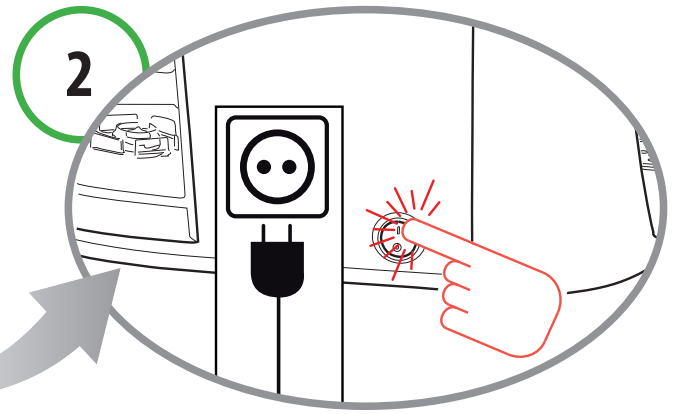

Brancher la fiche sur la prise de courant et allumer l'appareil.

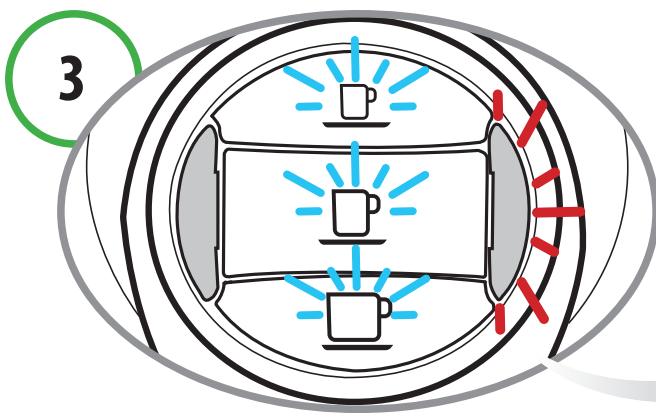

Les touches (**expresso**, **café allongé** et **café filtre**) et le voyant multifonction clignotent en même temps.

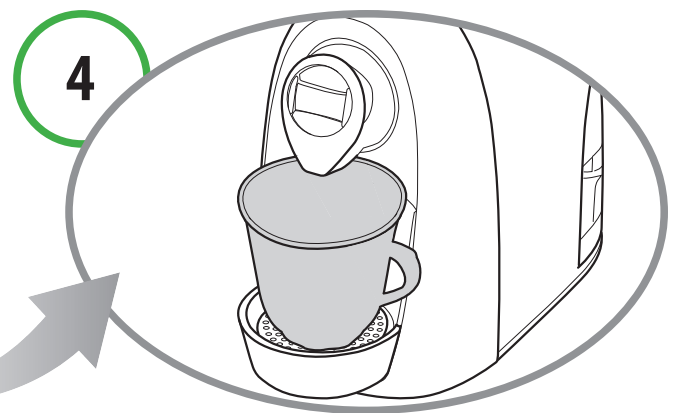

Placer un grand récipient sous la buse de distribution.

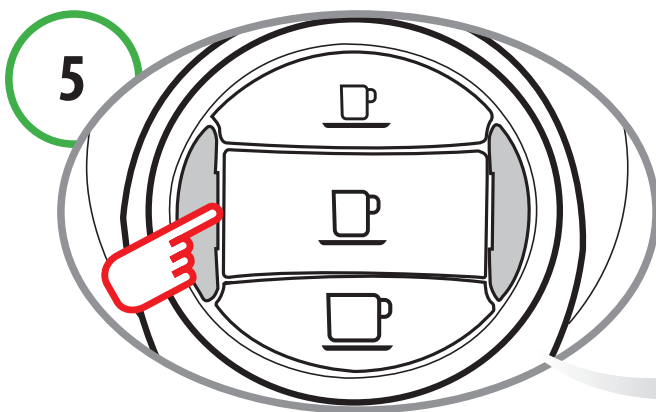

Appuyer sur l'une des touches café (**expresso**, **café allongé**, **café filtre**). Attendre que la machine termine le cycle de chargement du circuit hydraulique. Le voyant **multifonction** s'éteint.

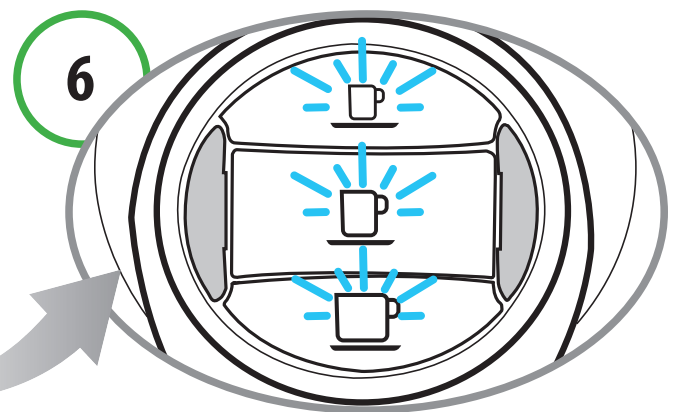

Les touches (**expresso**, **café allongé**, **café filtre**) clignotent en même temps ; la machine est en phase de réchauffement.



NOTA BENE :

Si au terme du chargement, les touches café et le voyant **multifonction** continuent de clignoter, répéter les opérations du point 5.

2 Allumer l'appareil

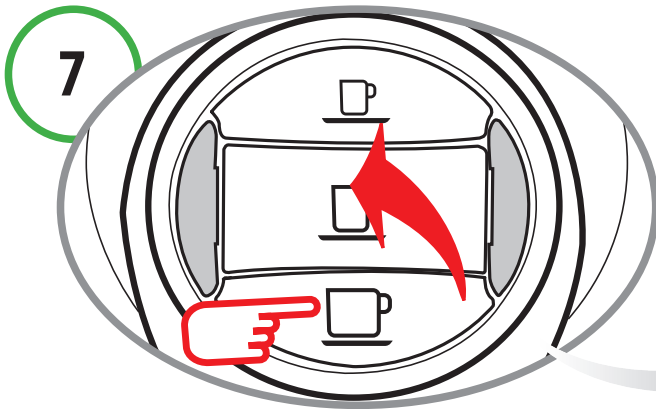

Quand les touches (**expresso**, **café allongé** et **café filtre**) s'allument en permanence, effectuer deux rinçages en appuyant sur la touche **café filtre**.

Attendre que la machine termine le cycle de rinçage.

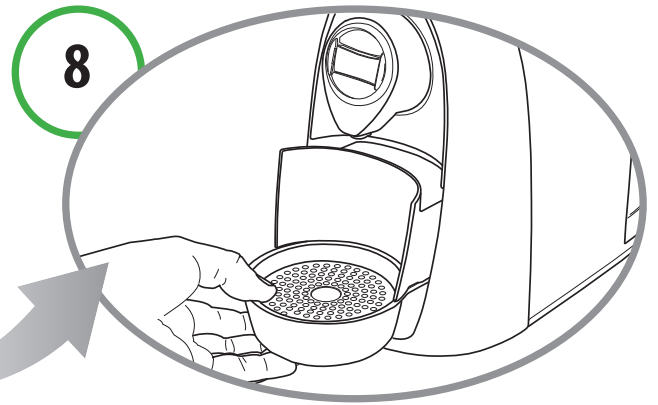

À la fin de l'opération, éliminer l'eau du réservoir à capsules usagées.

2 Allumer l'appareil

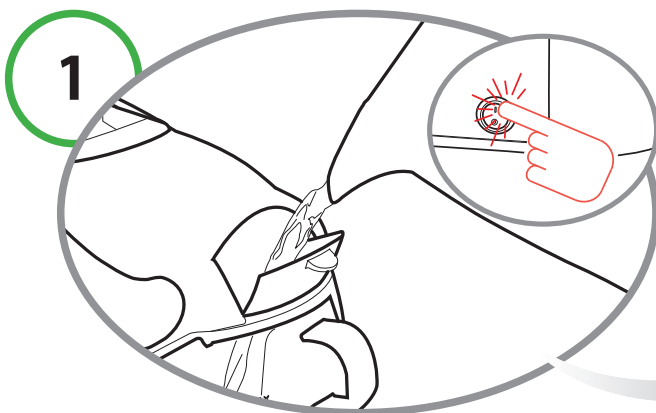

Remplir le réservoir avec de l'eau fraîche (non pétillante). Allumer l'appareil.

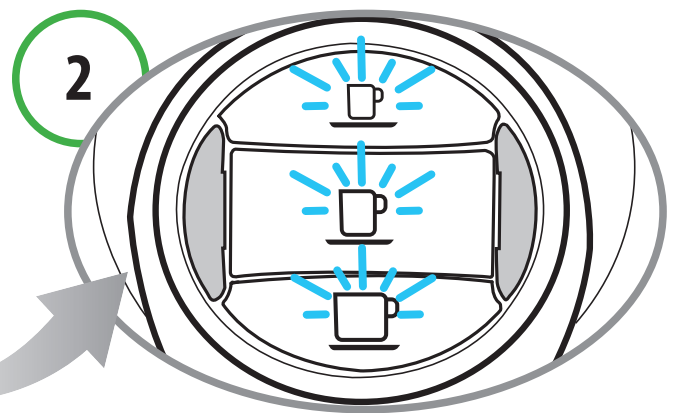

Les touches (**expresso**, **café allongé** et **café filtre**) clignotent en même temps ; la machine est en phase de réchauffement. Lorsque les touches sont allumées de façon fixe, la machine est prête à l'emploi.

Signal Détartrage

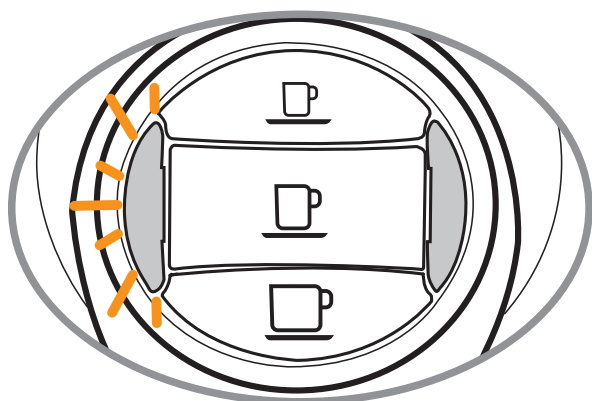

Lorsque le voyant **détartrage** clignote en ORANGE, et que la machine émet 3 signaux sonores, il est conseillé de procéder au cycle de détartrage (voir chap. 9).

Réchauffement

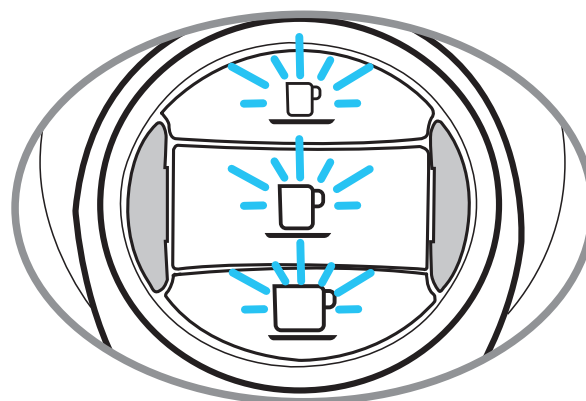

Les touches (**expresso**, **café allongé** et **café filtre**) clignotent en même temps.

Si l'eau s'épuise pendant le fonctionnement

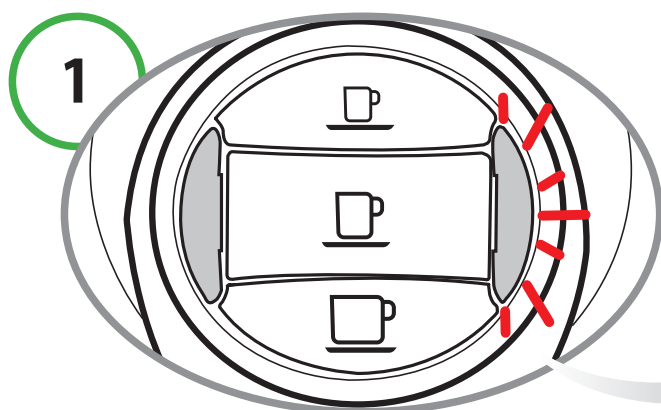

Quand le voyant **multifonction** clignote en ROUGE et que la machine émet au début 3 signaux sonores suivis ensuite d'un signal intermittent, le réservoir à eau est vide.

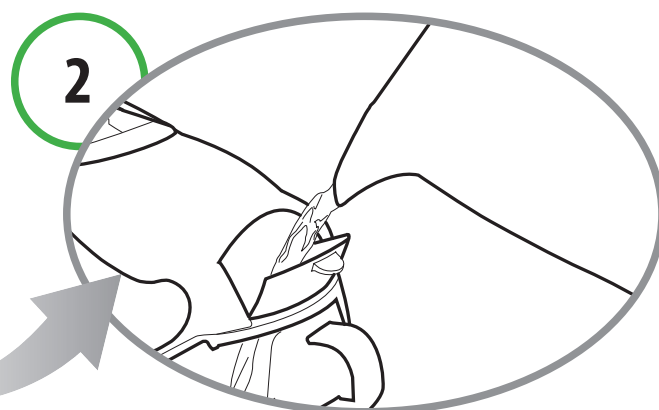

Remplir le réservoir avec de l'eau fraîche (non pétillante).

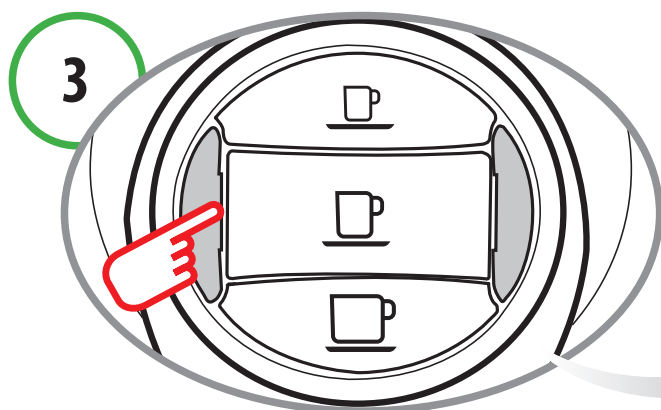

Appuyer sur l'une des touches café (**expresso**, **café allongé** ou **café filtre**). Attendre que la machine termine le cycle de chargement du circuit hydraulique.

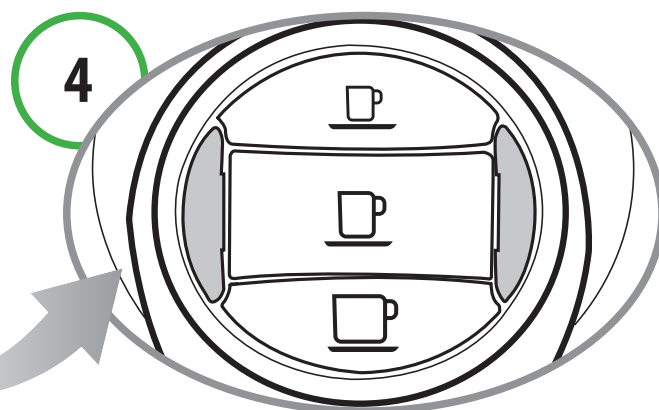

Lorsque les touches sont allumées de façon fixe, la machine est prête à l'emploi.

Si l'on soulève la poignée



ATTENTION !

Si l'utilisateur lève la poignée de manière inopportune pendant la distribution d'un produit, de l'eau chaude risque de gicler brièvement.
Risque de brûlure !

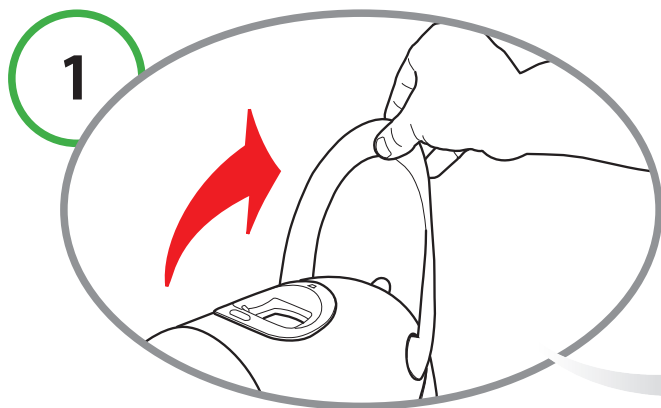

Si l'on soulève la poignée pendant la distribution d'un produit.

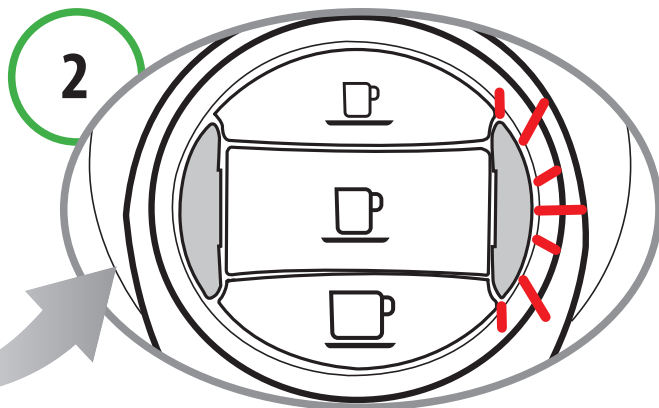

Le voyant **multifonction** clignote en ROUGE et un signal sonore intermittent est émis. La distribution est immédiatement interrompue.

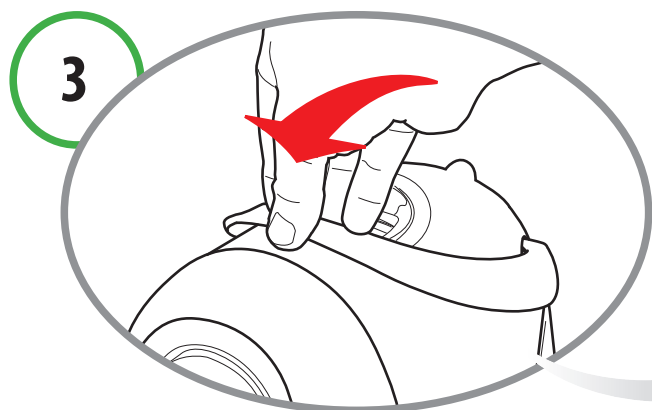

Fermer la poignée.

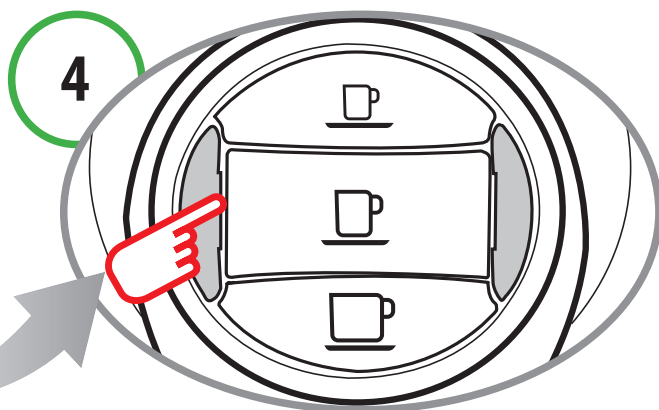

Appuyer sur une touche pour remettre à zéro l'alarme.
La machine est prête à être utilisée.

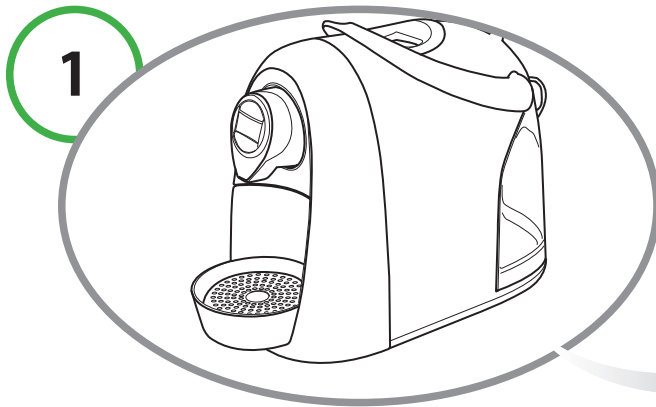

Il est possible de régler la machine pour permettre l'utilisation correcte de grandes tasses ou de petites tasses.

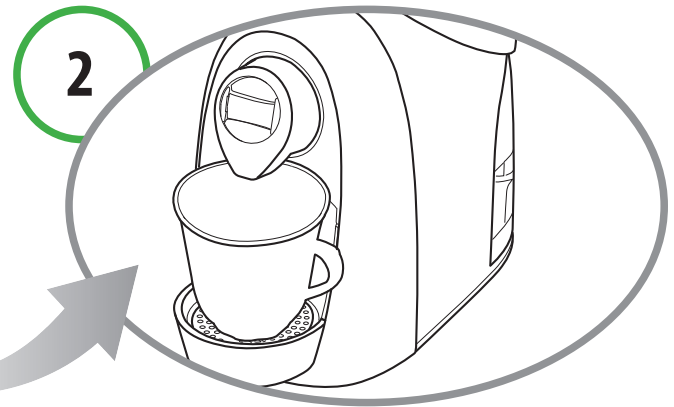

À l'origine, la machine est configurée pour l'utilisation de grandes tasses ou mug.

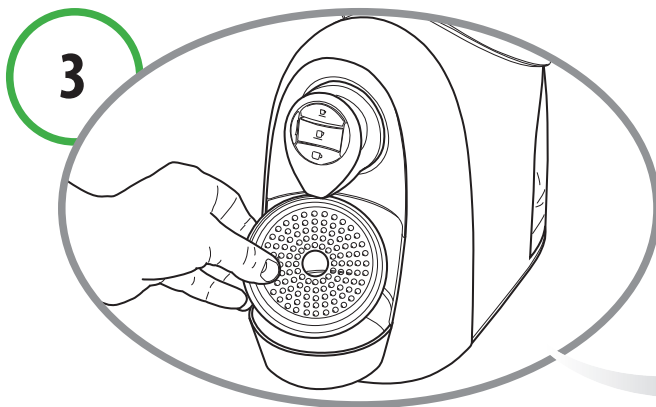

Pour l'utilisation de petites tasses, il faut soulever et pivoter la grille présente sur le bac d'égouttement.

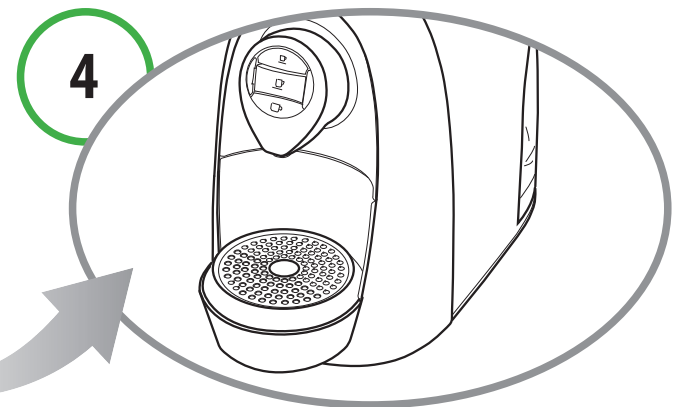

La grille doit être placée en position pivotée sur le bac d'égouttement.

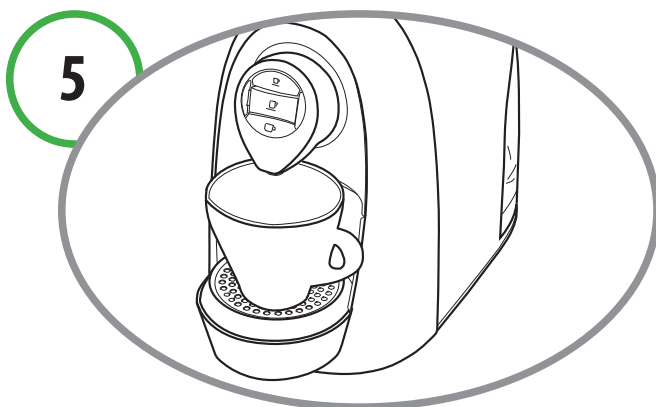

De cette façon, on peut utiliser des petites tasses et obtenir un meilleur résultat.

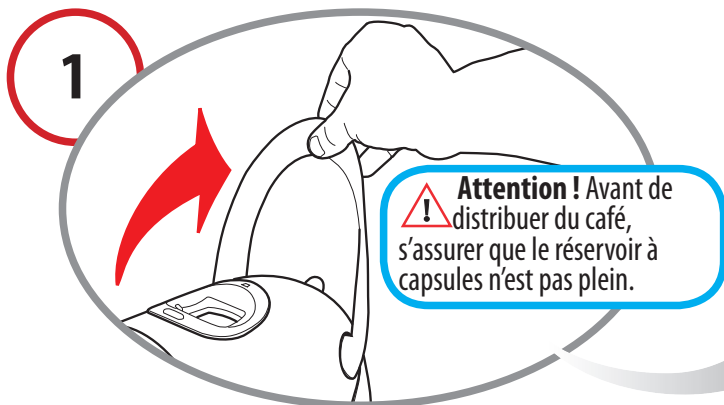

Soulever la poignée pour ouvrir le logement porte-capsules.

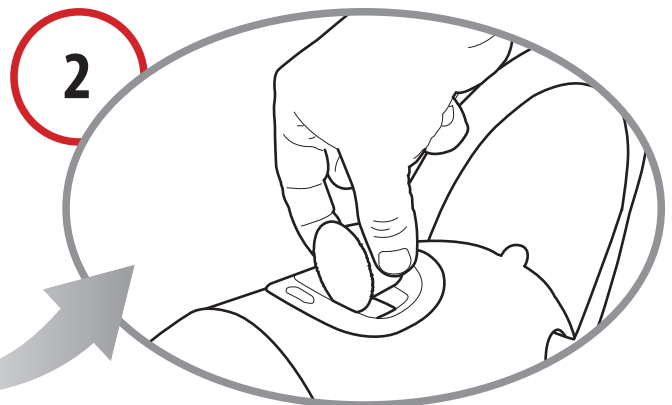

Introduire la capsule en la poussant à l'intérieur avec une légère pression.

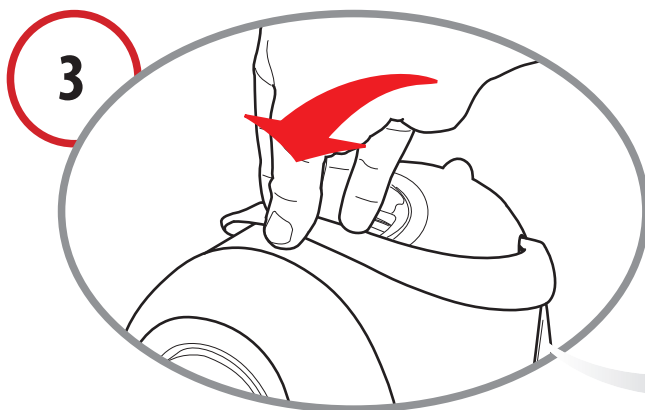

Bien fermer la poignée.

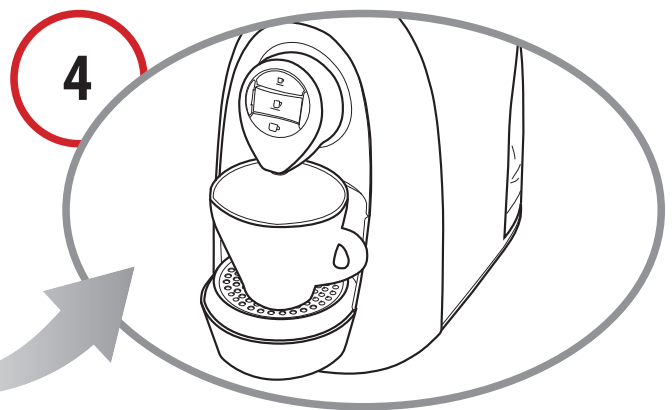

Placer une grande tasse/petite tasse sous la buse de distribution du café.

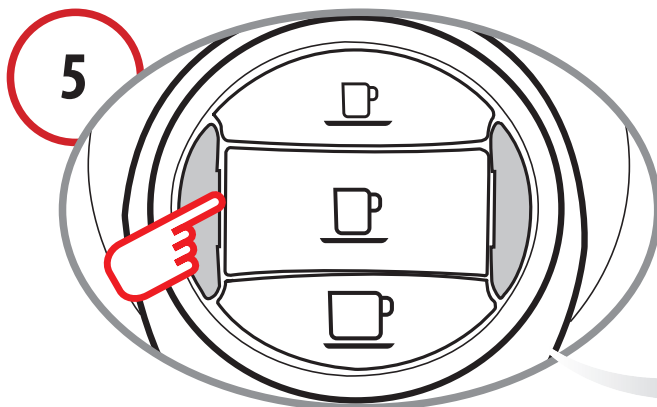

Appuyer une seule fois sur la touche du café désiré.

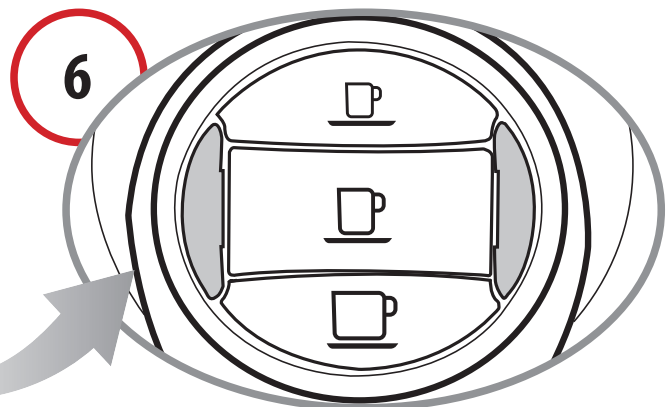

La touche du café sélectionné clignote. La distribution s'arrête lorsque la quantité programmée est atteinte et la machine émet un signal sonore.

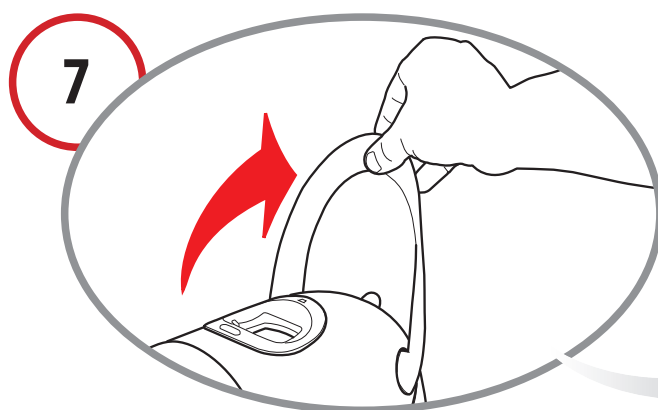

7 Soulever la poignée pour éjecter la capsule qui tombe dans le réservoir approprié.

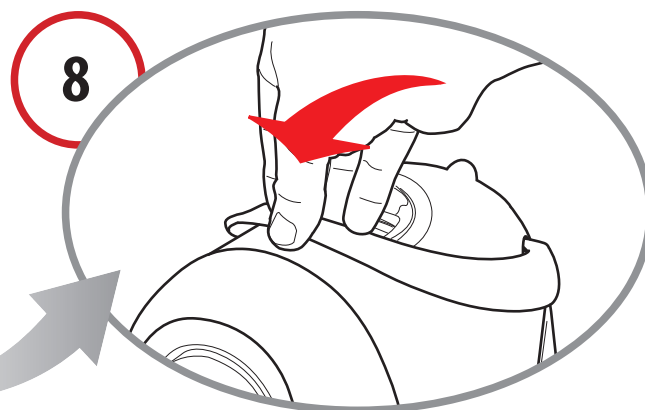

8 Fermer la poignée.



NOTA BENE :

Les quantités de café distribué peuvent être **reprogrammées** à volonté selon les goûts personnels et les dimensions des tasses utilisées (grandes ou petites). Pour reprogrammer la quantité, consulter la section 7.

6 Préparation d'autres boissons

Des capsules pour préparer des boissons à base de **thé, camomille, café filtre, etc.** sont disponibles.

Pour les utiliser, procéder comme indiqué dans le chapitre précédent ; une fois arrivé au point 5, appuyer sur la touche « **Café filtre** ».

Pour préparer des boissons avec des capsules **d'orge, des boissons au cacao, etc.**, procéder comme indiqué au chapitre précédent ; au point 5, appuyer sur la touche « **Espresso** » ou « **Café allongé** » selon les quantités souhaitées.



NOTA BENE :

Dans le circuit de la machine, il se peut qu'il reste des traces du produit qui vient d'être distribué.

Pour préserver le plus possible le goût, il est recommandé, lorsque l'on passe d'un produit à l'autre, de rincer rapidement ; le rinçage se fait en distribuant un café sans insérer de capsule.

7 Programmation quantité de café dans la tasse

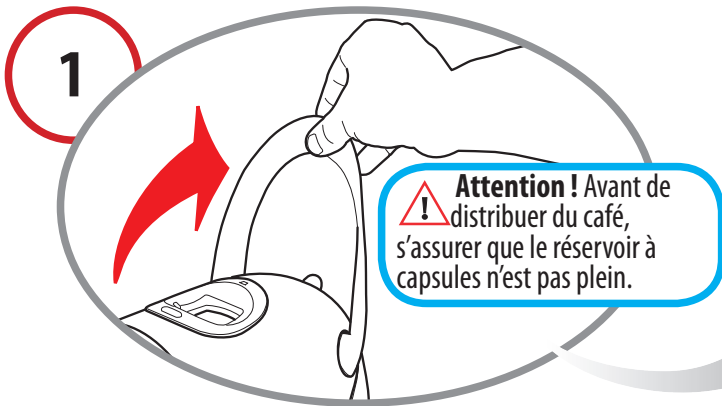

Soulever la poignée pour ouvrir le logement porte-capsules.

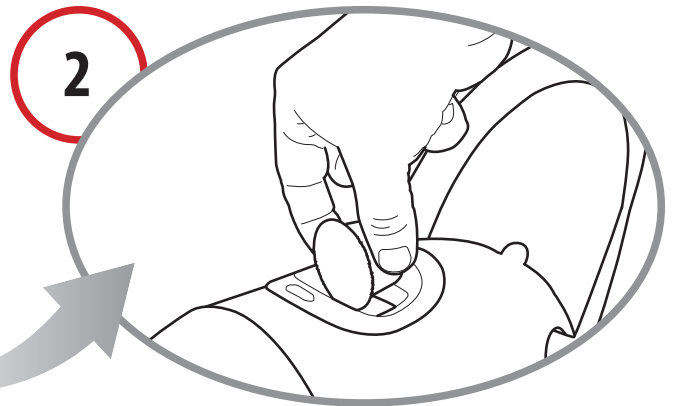

Introduire la capsule en la poussant à l'intérieur avec une légère pression.

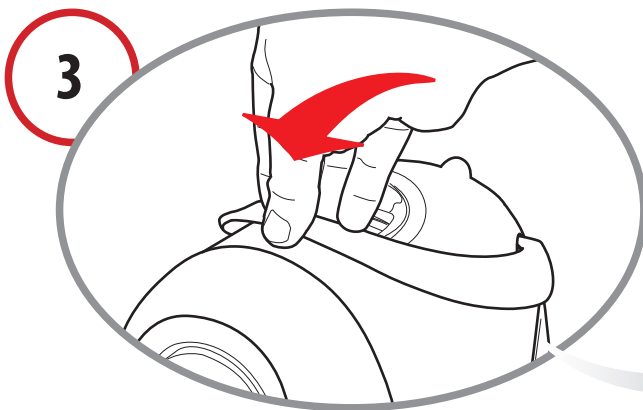

Bien fermer la poignée.

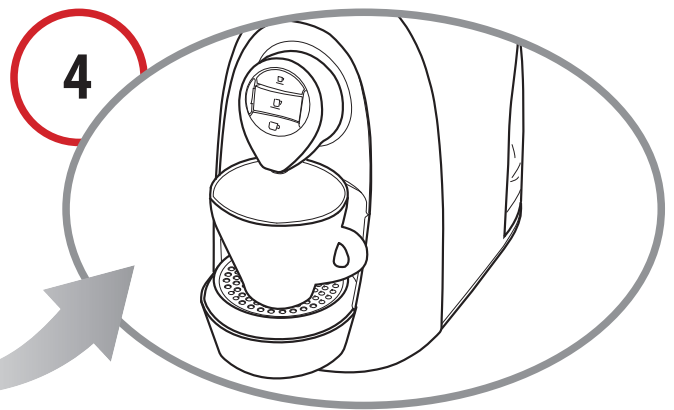

Placer une grande tasse/petite tasse sous la buse de distribution du café.

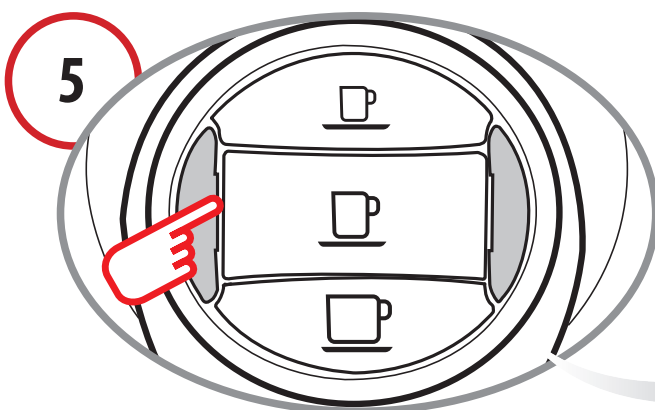

Appuyer sur la touche du café désiré et la **maintenir enfoncée..**

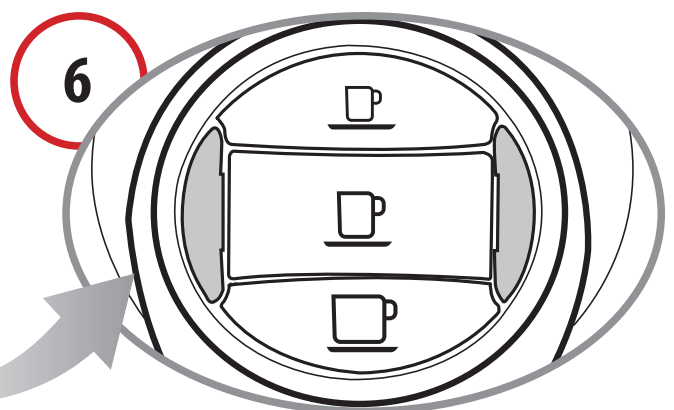

Une fois la quantité de café souhaitée atteinte, relâcher la touche. Maintenant la touche est programmée. Pour reprogrammer la touche qui vient d'être programmée ou programmer une autre touche, répéter les opérations.
La quantité de café distribué peut être programmée jusqu'à un maximum de 250 ml.

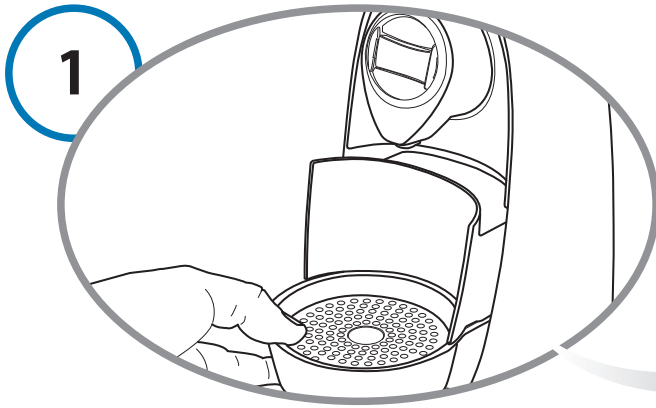

1
Extraire le bac d'égouttement et le réservoir à capsules usagées.

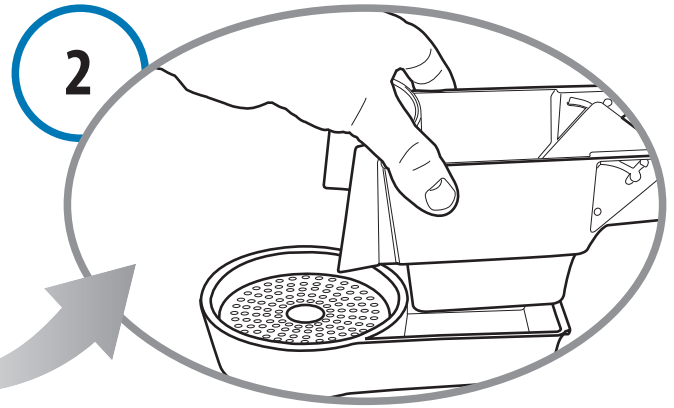

2
Soulever le réservoir à capsules usagées ; le vider et le rincer.

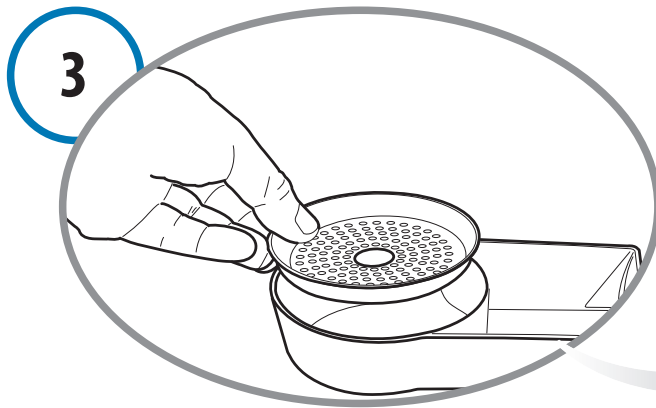

3
Enlever la grille. Vider le bac d'égouttement et le rincer à l'eau fraîche.

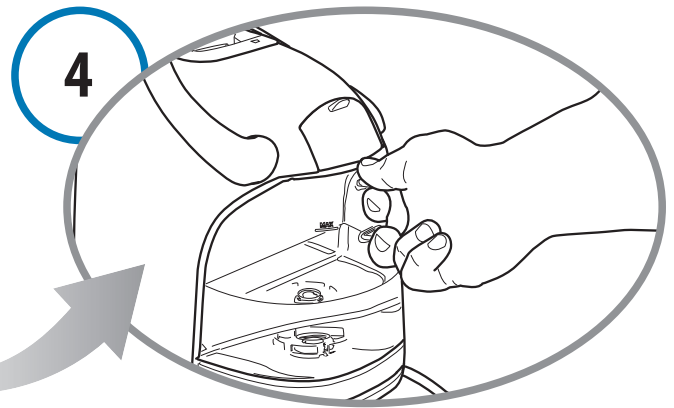

4
Extraire le réservoir à eau. Vider et rincer le réservoir. Le réservoir **NE DOIT PAS** être lavé au lave-vaisselle.



Pour le nettoyage de la surface de l'appareil, utiliser un chiffon doux et un détergent neutre. Ne pas utiliser de jets d'eau pour nettoyer l'appareil.



Les composants en plastique ne peuvent pas être lavés au lave-vaisselle.

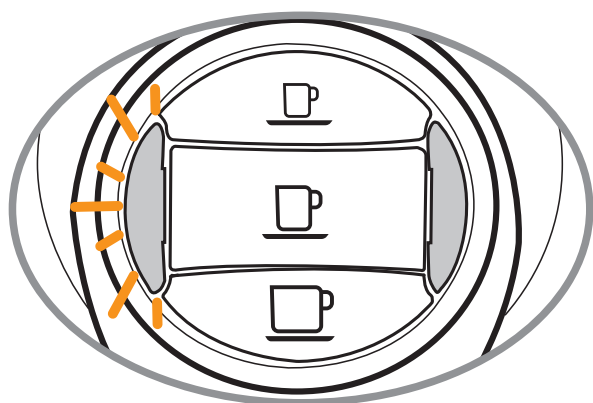

La machine dispose d'un programme avancé qui vérifie la quantité d'eau utilisée pour la distribution des produits. Cette mesure permet d'informer l'utilisateur quand la machine a besoin d'un cycle de détartrage. Les indications spécifiques sont traitées dans la section 3.

Lorsque le voyant **détartrage** clignote en ORANGE, et que la machine émet 3 signaux sonores, il est conseillé de procéder au cycle de détartrage (voir chap. 9).



Lire **ATTENTIVEMENT** | les précautions d'emploi se trouvant sur l'emballage du détartrant. Éviter le contact avec les yeux, la peau et les surfaces de la machine. Ne pas éteindre la machine et ne pas soulever la poignée durant le détartrage. Une personne doit être présente pendant cette opération.

Ne pas utiliser de vinaigre : il peut endommager votre machine !

Nous vous conseillons d'utiliser le détartrant Caffita System, qui a été mis au point spécialement pour respecter les caractéristiques techniques de la machine, en toute sécurité pour le consommateur. La solution détartrante doit être éliminée selon les indications du fabricant et/ou les normes en vigueur dans le pays d'installation de la machine.

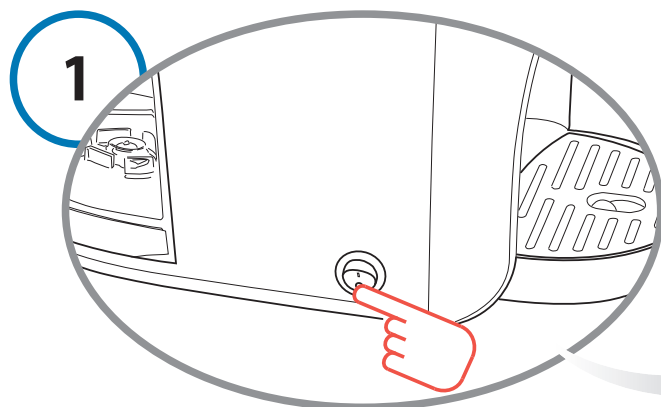

Éteindre la machine.

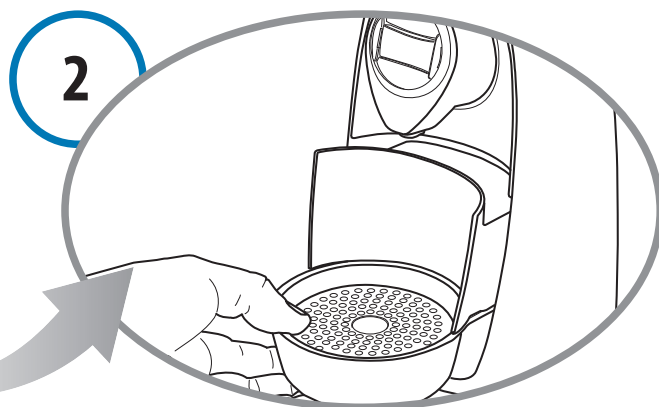

Vider et rincer le réservoir à capsules usagées et le bac d'égouttement.

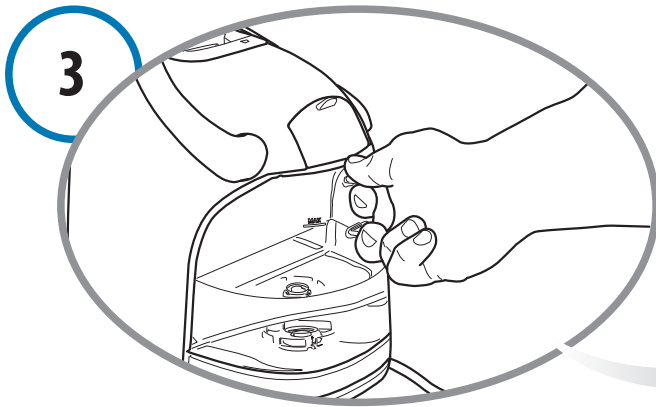

Extraire et vider le réservoir à eau.

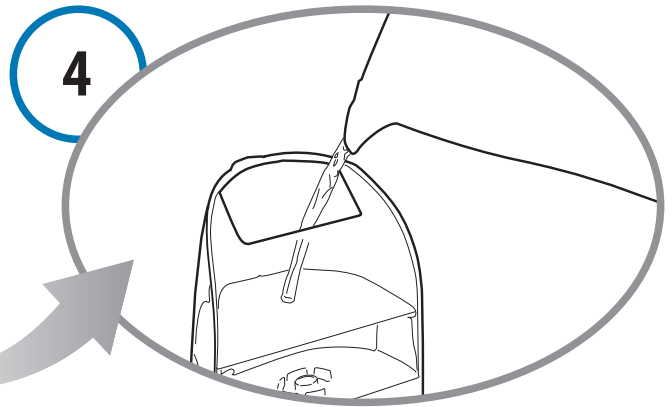

Mélanger le détartrant dans de l'eau, comme indiqué sur l'emballage, et verser cette solution dans le réservoir.

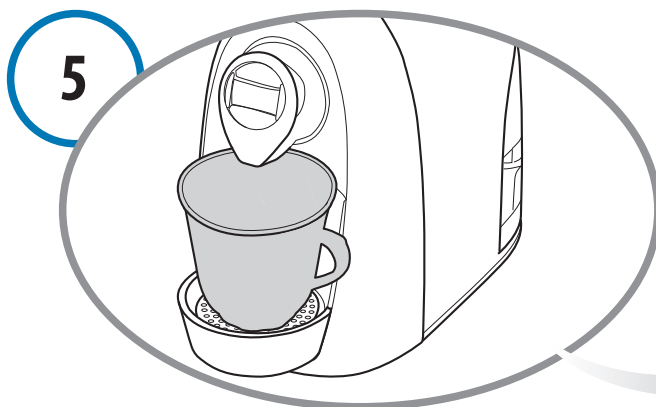

Placer un récipient (au moins 250 ml) sous la buse de distribution.

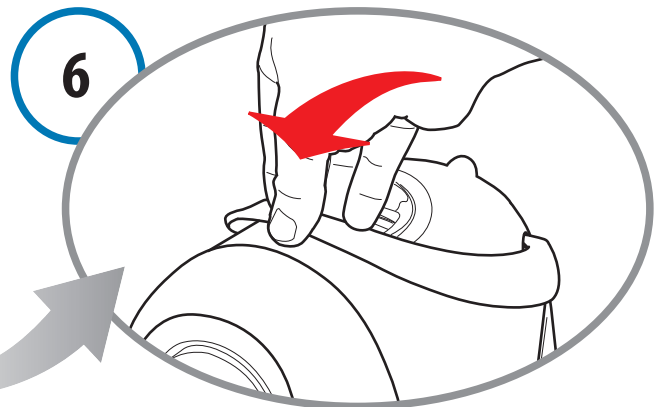

S'assurer que la poignée est baissée.

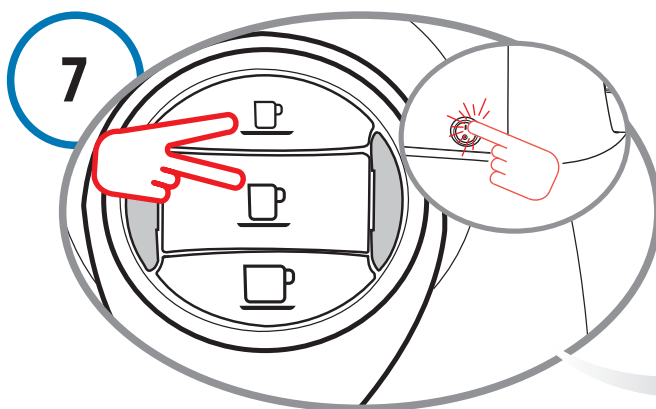

Maintenir les touches (**Espresso** et **café allongé**) enfoncées et allumer en même temps la machine en appuyant sur l'interrupteur général.

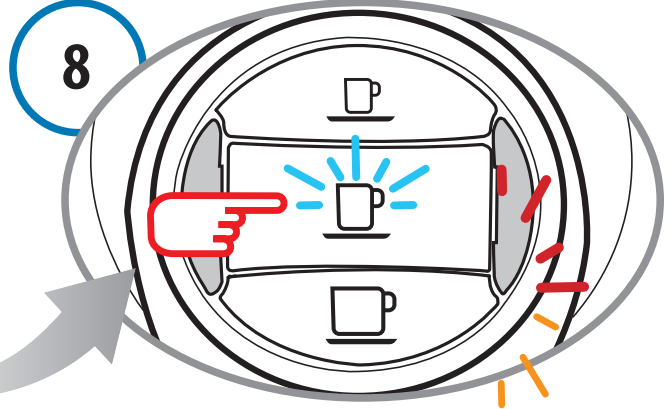

Parallèlement à la touche **café allongé**, le voyant **multifonction** clignote alternativement (ROUGE et ORANGE). Appuyer sur la touche **café allongé** pour commencer le cycle de détartrage.

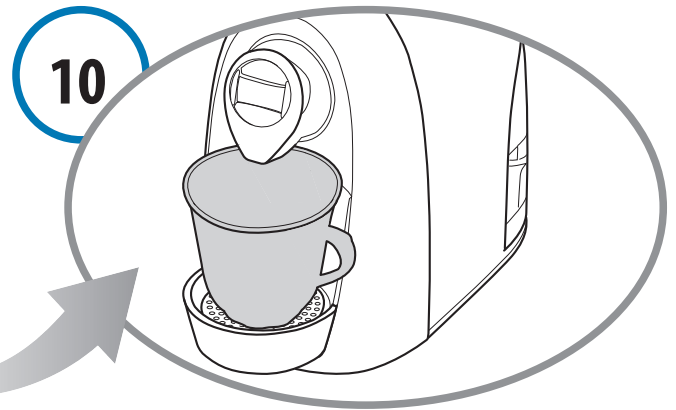
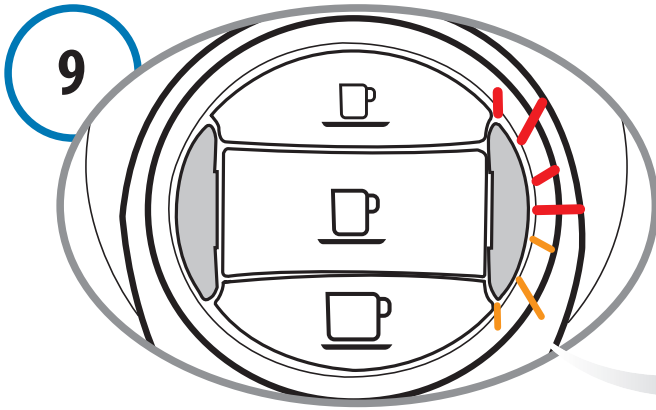

La machine distribue la solution de détartrage par intervalles (**5 distributions séparées par une pause de 10 minutes, pendant environ 45 minutes**). Pendant cette phase, **au cours de laquelle il ne faut appuyer sur aucun bouton**, le témoin **multifonction** clignote de façon alternée (ROUGE et ORANGE).

Si le récipient est plein, procéder à son vidage.

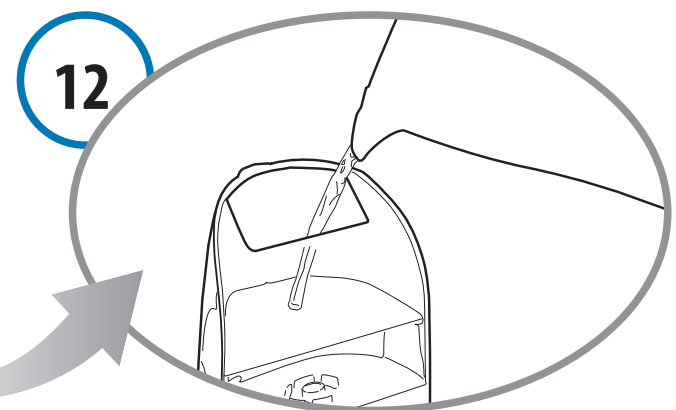
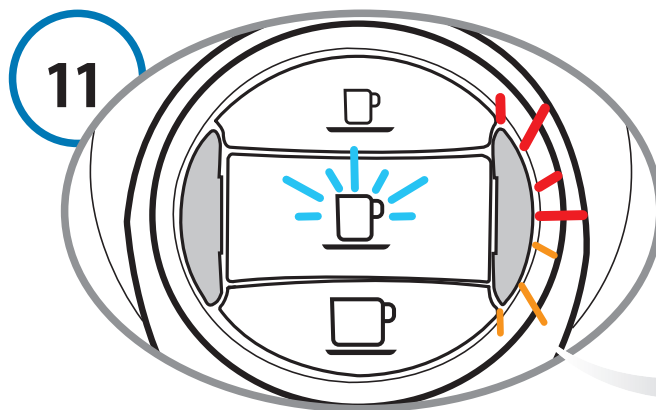

Lorsque le cycle est terminé, le voyant **multifonction** clignote alternativement (ROUGE et ORANGE), parallèlement à la touche **café allongé**.

Rincer soigneusement le réservoir à eau et le remplir avec de l'eau potable fraîche.

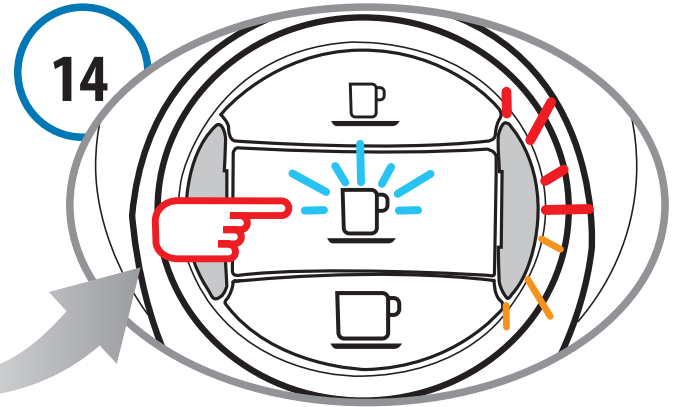
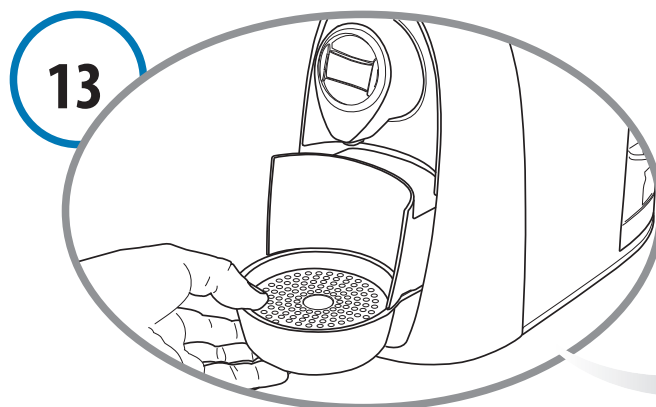

Vider et rincer le réservoir à capsules usagées et le bac d'égouttement.

Parallèlement à la touche **café allongé**, le voyant **multifonction** clignote alternativement (ROUGE et ORANGE). Appuyer sur la touche **café allongé** pour commencer le cycle de rinçage.

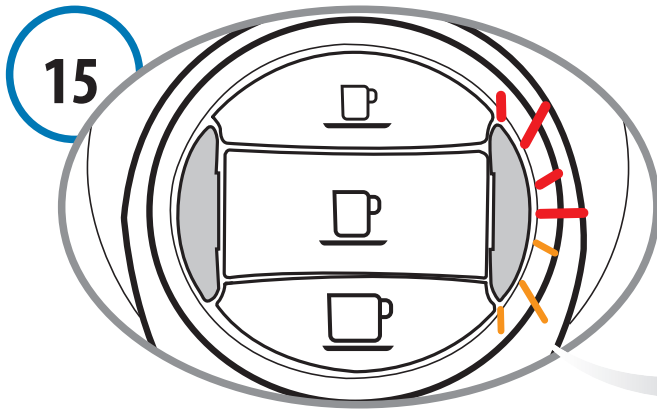

La machine distribue l'eau de rinçage. Pendant cette phase, le voyant **multifonction** clignote de façon alternée (2 fois ROUGE et 2 fois ORANGE).

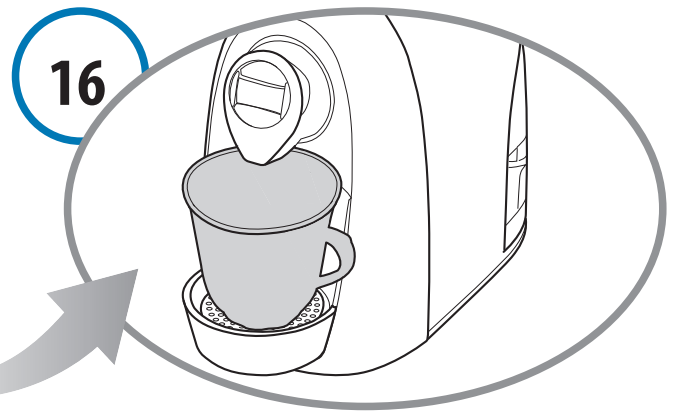

Si le récipient est plein, procéder à son vidage.

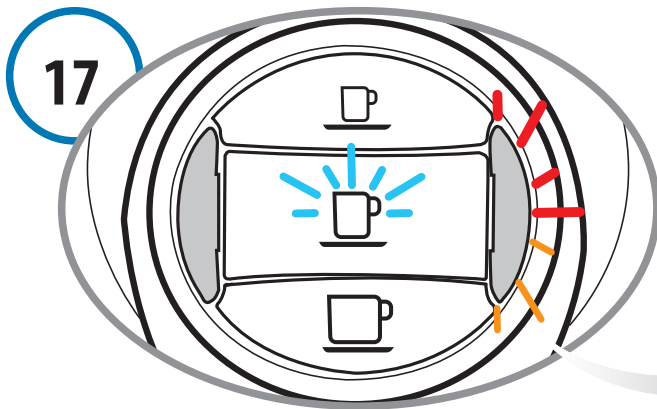

Lorsque le cycle de rinçage est terminé, le voyant **multifonction** clignote alternativement (ROUGE et ORANGE), parallèlement à la touche **café allongé**. La machine émet un signal sonore.

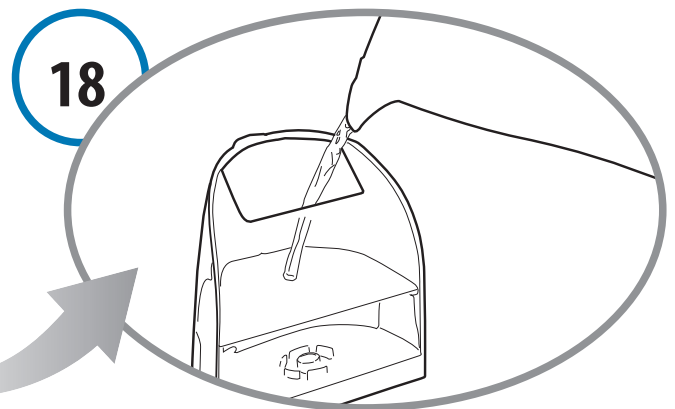

Rincer soigneusement le réservoir à eau et le remplir avec de l'eau potable fraîche.

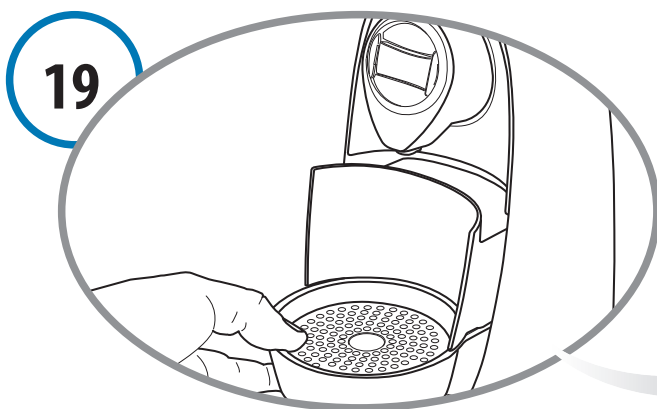

Vider et rincer le réservoir à capsules usagées et le bac d'égouttement.

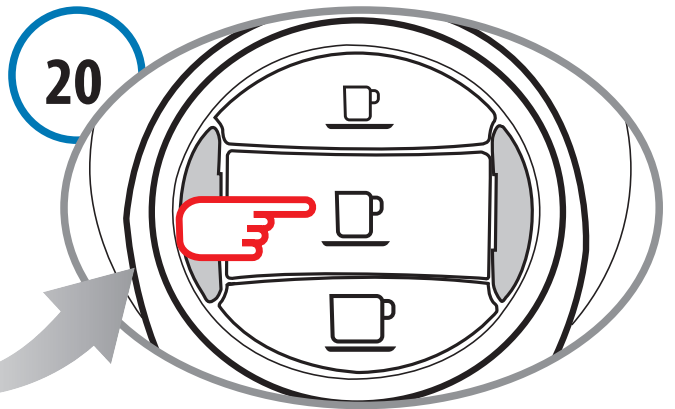









Appuyer sur la touche **café allongé** pour sortir du cycle.



Pour le nettoyage de la surface de l'appareil, utiliser un chiffon doux et un détergent neutre.

PROBLÈME	CAUSE	SOLUTION
- Le café ne coule pas.	- Le réservoir à eau est vide, le voyant multifonction est allumé en ROUGE.	- Remplir le réservoir avec de l'eau fraîche. Appuyer sur l'une des touches café pour effectuer le chargement du circuit.
- Le café n'est pas assez chaud.	- Grandes tasses/petites tasses froides. - Machine avec calcaire.	- Préchauffer la grande tasse/petite tasse. - Détartre.
- La poignée ne peut pas être baissée.	- Le réservoir à capsules usagées est plein. - Capsule bloquée à l'intérieur de la machine.	- Vider le réservoir à capsules usagées. - Enlever la capsule usagée.

11 Données techniques

	Consulter la plaquette reportant les données sur le fond de la machine		
P	Max. 15 bars		
	< 70dB A		
	Environ 4 kg		
	1,2 litres		
	température ambiante: 10°C ÷ 40°C		
	170 mm	 260 mm	 320 mm

Les matériaux et les objets destinés au contact des produits alimentaires sont conformes aux indications de la réglementation européenne 1935/2004.

Einleitung

- Bestimmungsgemäße Verwendung.....3
- Warn- und Hinweissymbole3
- Ihr Kontakt zu Caffitaly System.....3
- Sicherheitshinweise4
- Hinweise zu Betrieb und Entsorgung.....5
- Beschreibung der Maschinenkomponenten6

Installation

- 1 Bei der ersten Inbetriebnahme oder nach einer längeren Betriebspause7
- 2 Einschalten des Gerätes8
- 3 Allgemeine Betriebsanzeigen.....9
- 4 Höheneinstellung Kaffee-/Espressotasse..... 11

Ausgabe des Produktes

- 5 Ausgabe von Kaffee 12
- 6 Zubereitung von anderen Getränken 13
- 7 Programmierung der Kaffeemenge pro Tasse..... 14

Reinigung und Instandhaltung

- 8 Tägliche Reinigung 15
- 9 Entkalkung 16

Verschiedenes

- 10 Störungssuche 20
- 11 Technische Daten 20

*Sehr geehrte Kundin, sehr geehrter Kunde,
wir danken Ihnen für die Wahl unseres Erzeugnisses und das uns entgegen-
brachte Vertrauen. Mit unserer Maschine und der Auswahl der von Caffitaly angebotenen Kapseln
können Sie Ihr Lieblingsgetränk zu jeder Tageszeit genießen. Zum Beispiel: einen Espresso, ein Kakaoge-
tränk oder einen Tee, die in wenigen Sekunden zubereitet sind.*

Bestimmungsgemäße Verwendung

Dieses Gerät ist für den Hausgebrauch und ähnliche Zwecke bestimmt wie beispielsweise

- in Personalküchen in Geschäften, Büros und sonstigen Arbeitsumgebungen;
- in agritouristischen Betrieben;
- zur Nutzung durch Gäste in Hotels, Motels und sonstigen Unterkünften;
- In „Bed and Breakfast“-Unterkünften.

Ausschließlich die spezifischen Caffita-System-Kapseln verwenden. Jede andere Verwendung, die nicht in dieser Bedienungsanleitung vorgesehen ist, kann Personenschäden verursachen und bewirkt den Verfall der Garantie.

Der Hersteller haftet nicht für Schäden, die auf unsachgemäße Verwendung des Geräts zurückzuführen sind.

Warn- und Hinweissymbole

ACHTUNG



Dies ist das Sicherheits- und Warnsymbol. Es wird benutzt, um die Aufmerksamkeit auf mögliche Verletzungsgefahren zu lenken. Die angegebenen Sicherheitshinweise beachten, um mögliche Verletzungen, auch mit Todesfolge, zu vermeiden.



HINWEIS

Dieses Symbol weist auf Möglichkeiten zur besseren Benutzung der Maschine hin.



Nicht spülmaschinenfest



Reinigungstipps



Dieses Symbol wird benutzt, um auf eine **WEISSE** Leuchtanzeige hinzuweisen.



Dieses Symbol weist auf eine **ROTE** Leuchtanzeige hin.



Dieses Symbol weist auf eine **ORANGEFARBENE** Leuchtanzeige hin.

Sicherheitshinweise

Die nachfolgenden Anleitungen aufmerksam durchlesen! So können Unfälle und Schäden am Gerät vermieden werden.

- Das Gerät auspacken und auf eventuelle Schäden untersuchen. Falls Schäden festgestellt werden, bei ersten Anzeichen einer Störung (anomales Betriebsgeräusch oder Gerüche) oder bei geräteinternen Störungen das Gerät nicht benutzen und sich an ein autorisiertes Kundendienstzentrum wenden.
- Die Verpackungsmaterialien (Kunststofftüten usw.) sind potenziell gefährlich und dürfen nicht in die Hände von Kindern gelangen.
- Das Gerät darf nur mit intaktem Netzkabel betrieben werden. Den Austausch eines defekten Netzkabels ausschließlich durch eine autorisierte Kundendienststelle vornehmen lassen. Gefahr tödlicher Stromschläge.
- Das Gerät nur in Innenräumen benutzen und lagern. Sicherstellen, dass elektrische Teile, Stecker und Kabel trocken sind. Das Gerät nicht in Wasser eintauchen. Das Gerät vor Spritz- und Tropfwasser schützen. Die Kombination von Elektrizität und Wasser stellt eine tödliche Gefahr durch Stromschläge dar.
- Das Gerät nur an Steckdosen anschließen, die den gesetzlichen Bestimmungen entsprechen. Sicherstellen, dass die Netzspannung der Angabe auf dem Typenschild auf der Geräteunterseite entspricht.
- Die Oberfläche, auf der das Gerät aufgestellt wird, muss eben (max. Neigung: 2°), robust, standfest und hitzebeständig sein.
- Das Gerät darf nicht von Personen (einschließlich Kindern) mit eingeschränkten geistigen, körperlichen oder sensorischen Fähigkeiten oder ungenügender Erfahrung und Kenntnissen benutzt werden, soweit sie nicht durch eine für ihre Sicherheit verantwortliche Person aufmerksam überwacht und angeleitet werden. Kinder müssen beaufsichtigt werden, um sicherzustellen, dass sie nicht mit dem Gerät spielen.
- Das Netzkabel nicht in der Nähe von heißen Flächen, Kanten oder scharfen Gegenständen lassen. Nie die Hände in den Kapselraum einführen. Verletzungsgefahr!
- Den Hebel immer schließen. Den Hebel nie öffnen, wenn das Gerät in Betrieb ist.
- Keine Maschinenteile entfernen. Keine Gegenstände in die Öffnungen einführen; hierbei besteht
- Stromschlaggefahr! Alle Eingriffe, die nicht in dieser Anleitung aufgeführt sind, dürfen nur durch eine autorisierte Kundendienststelle durchgeführt werden!

- Das Netzkabel immer vorsichtig am Stecker und nicht am Kabel aus der Steckdose herausziehen.
- Die Maschine in regelmäßigen Abständen und unter Beachtung der Anleitungen entkalken. Im gegenteiligen Fall könnte das Gerät beschädigt werden und Gesundheitsschäden verursachen.
- Das Gerät gründlich und regelmäßig reinigen. Die Ablagerungen, die sich bei unzureichender Reinigung bilden, können gesundheitsschädlich sein. Vor der Reinigung das Gerät vom Stromnetz trennen und abkühlen lassen.
- Soll das Gerät für einen längeren Zeitraum nicht benutzt werden (Urlaub usw.), den Stecker aus der Steckdose ziehen.

Hinweise zu Betrieb und Entsorgung



Das Gerät wurde aus hochwertigen Materialien hergestellt, die wiederverwendet oder verwertet werden können. Das Gerät über eine entsprechende Sammelstelle entsorgen.



Um jeden unrechtmäßigen Gebrauch und hiermit verbundene Gefahren auszuschließen, muss das Gerät unbrauchbar gemacht werden, bevor es zur Sammelstelle für Elektroaltgeräte gebracht wird.

Zu diesem Zweck das Netzkabel ziehen, um das Gerät von der Stromversorgung zu trennen, und anschließend das Netzkabel so nah wie möglich am Gerät abschneiden.



Hinweise für die korrekte Entsorgung des Produkts gemäß der europäischen Richtlinie 2002/96/EC und der italienischen Gesetzesverordnung Nr. 151 vom 25. Juli 2005. Am Ende seines Lebenszyklus darf das Produkt nicht mit dem Hausmüll entsorgt werden. Es kann an entsprechenden Wertstoffsammelstellen der Gemeinden oder bei den Händlern, die diesen Service anbieten, abgegeben werden. Die getrennte Entsorgung von Haushalts-Elektrogeräten trägt zur Vermeidung von möglichen negativen Auswirkungen auf die Umwelt und auf die Gesundheit bei und ermöglicht die Wiederverwendung der Materialien, aus denen sie bestehen. Dadurch können Energie und Rohstoffe gespart werden. Auf die Pflicht zur separaten Entsorgung von Haushalts-Elektrogeräten weist auch das Symbol der durchgestrichenen Abfalltonne auf dem Produkt hin. Die ungesetzliche Entsorgung des Produkts durch den Besitzer zieht die Verhängung der von den geltenden Bestimmungen vorgesehenen Verwaltungsstrafen nach sich. Die Verpackung besteht aus wiederverwertbarem Material. Für Informationen zu den örtlich geltenden Vorschriften wenden Sie sich bitte an die zuständigen Behörden.

Beschreibung der Maschinenkomponenten

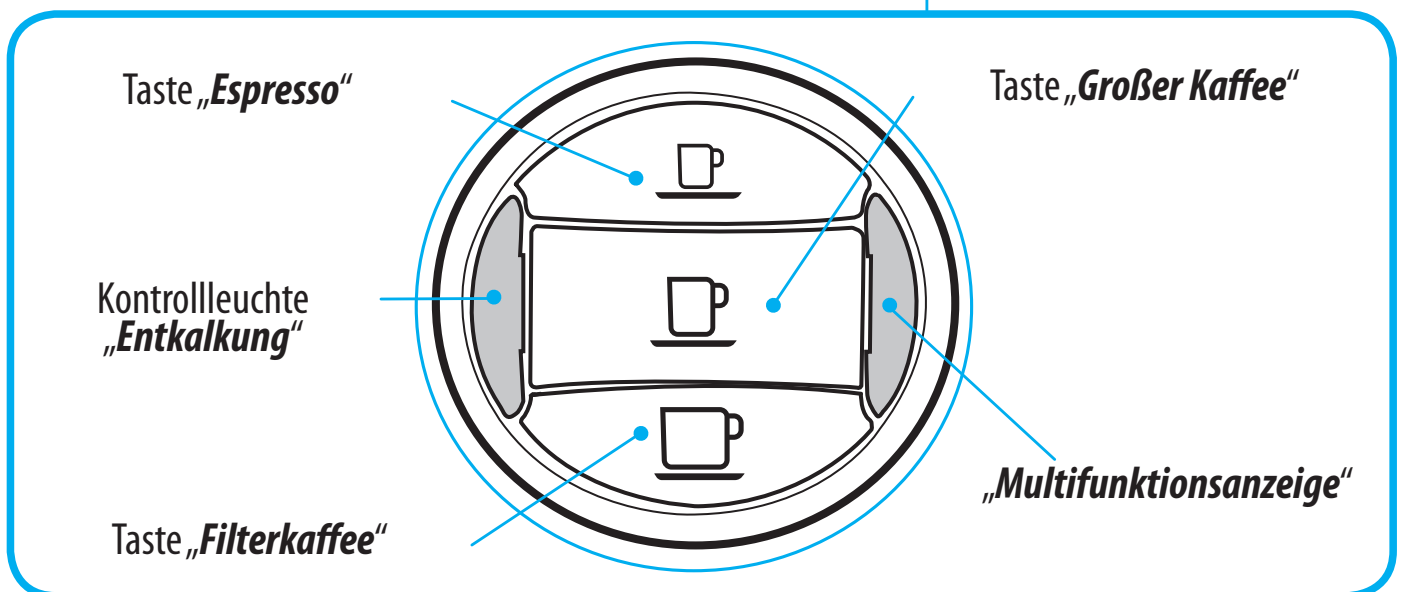
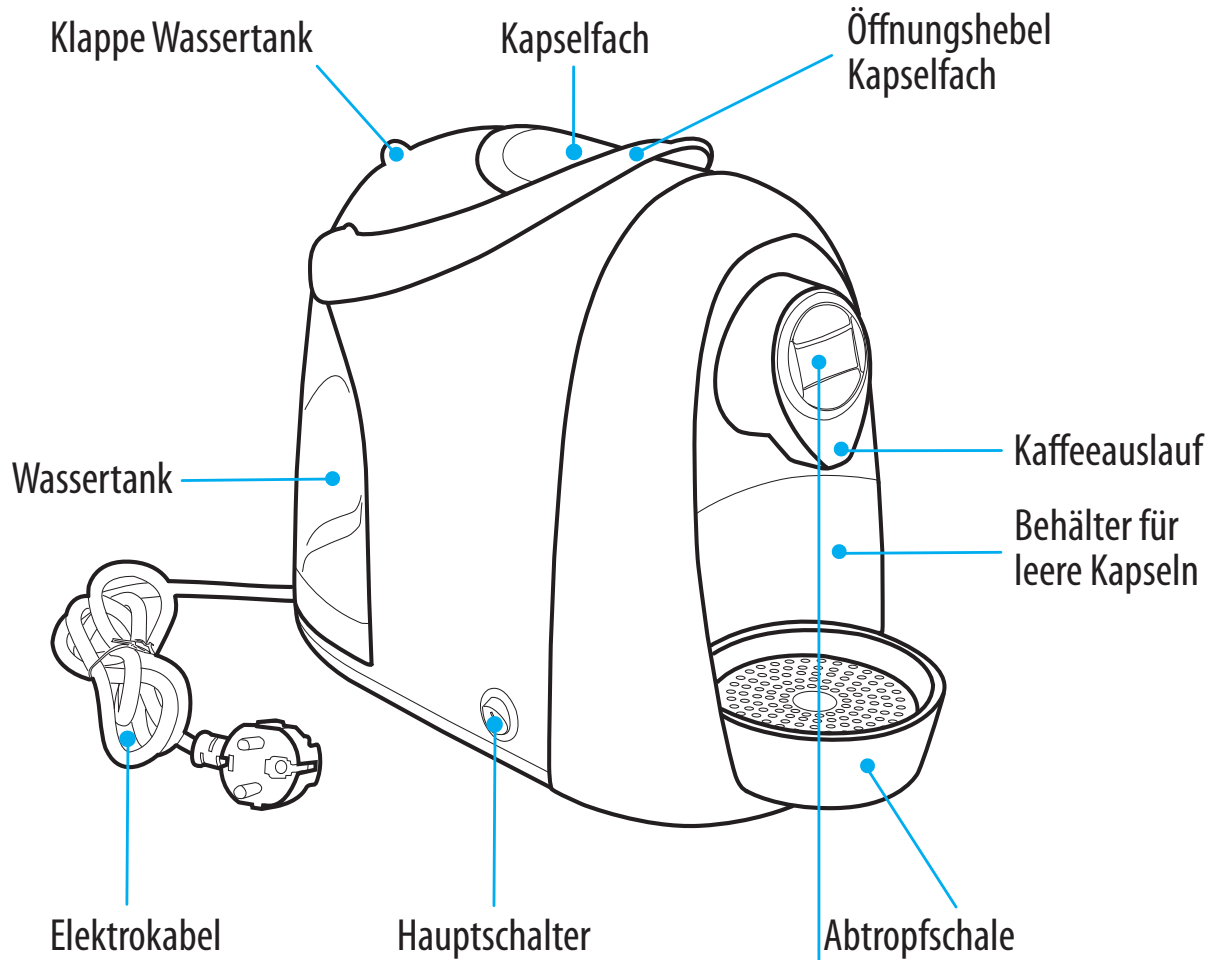

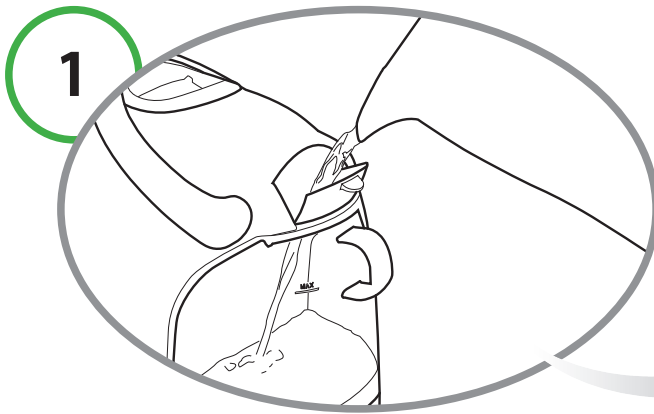

Den Wassertank mit frischem Wasser füllen (ohne Kohlensäure).

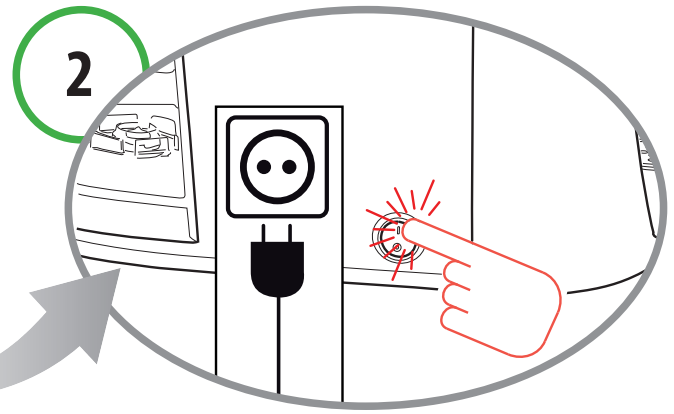

Den Stecker in die Steckdose einstecken und das Gerät einschalten.

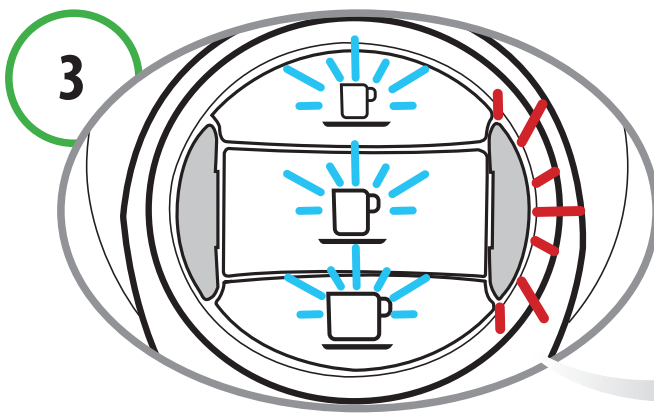

Die Tasten (**Espresso**, **Großer Kaffee** und **Filterkaffee**) und die Multifunktionsanzeige blinken gleichzeitig.

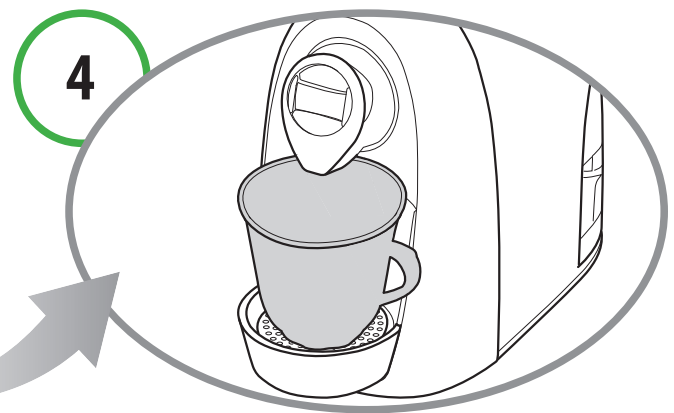

Einen ausreichend großen Behälter unter den Kaffeeauslauf stellen.

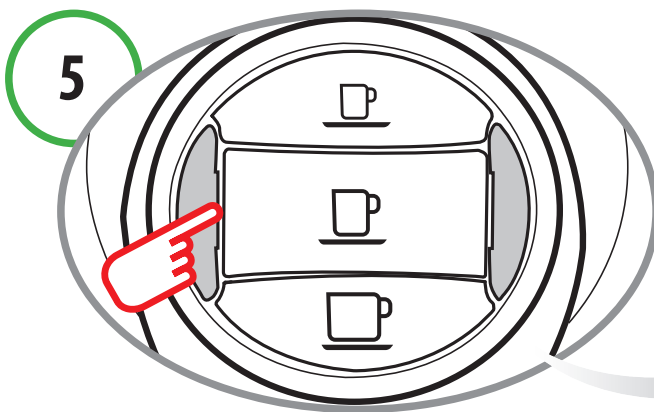

Eine der Kaffeetasten (**Espresso**, **Großer Kaffee** oder **Filterkaffee**) drücken. Warten, bis die Maschine den Befüllungszyklus der Wasserleitungen abgeschlossen hat. Die **Multifunktionsanzeige** erlischt.

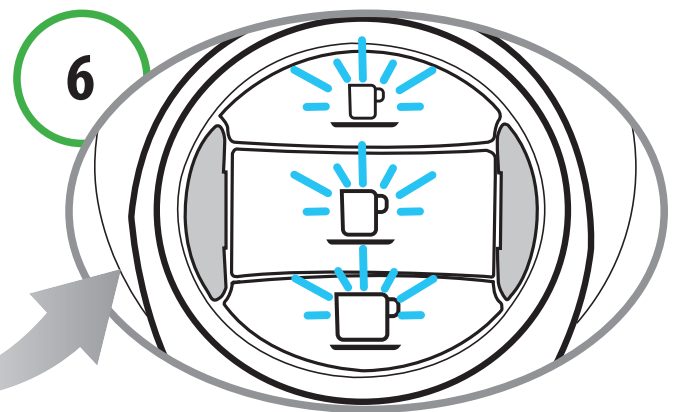

Die Tasten (**Espresso**, **Großer Kaffee** und **Filterkaffee**) blinken gleichzeitig; die Maschine ist in der Heizphase.



HINWEIS:

Wenn nach dem Füllen der Wasserleitungen die Kaffeetasten und die **Multifunktionsanzeige** weiter blinken, die bei Punkt 5 beschriebenen Schritte wiederholen.

2 Einschalten des Gerätes

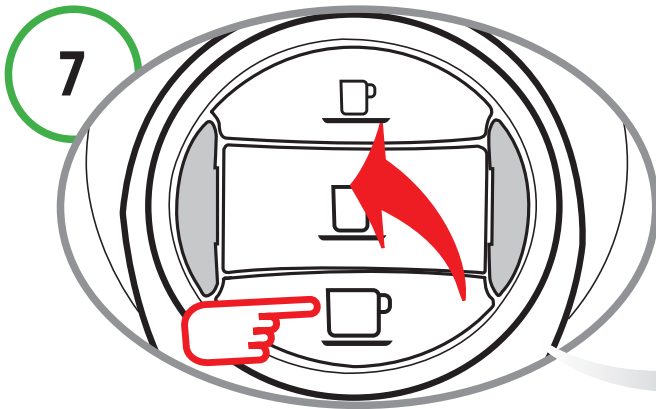

Sobald die Tasten (**Espresso**, **Großer Kaffee** und **Filterkaffee**) dauerhaft leuchten, die Taste **Filterkaffee** drücken und zwei Spülgänge ausführen.
Warten, bis die Maschine den Spülzyklus abgeschlossen hat.

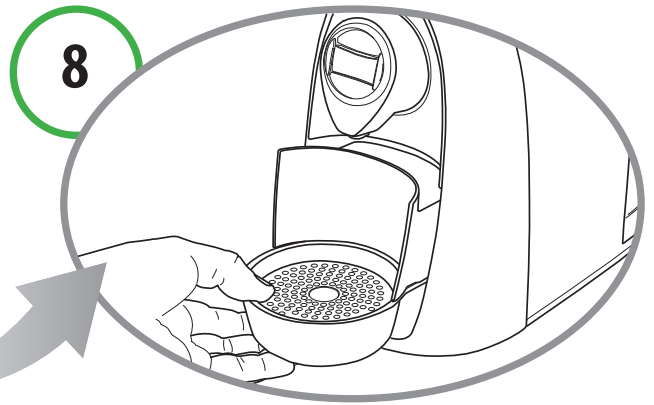

Am Ende des Vorgangs das Wasser im Behälter für leere Kapseln abgießen.

2 Einschalten des Gerätes

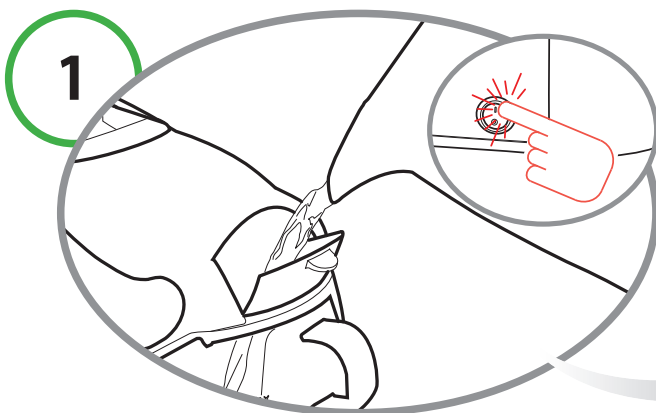

Den Wassertank mit frischem Wasser füllen (ohne Kohlensäure). Das Gerät einschalten.

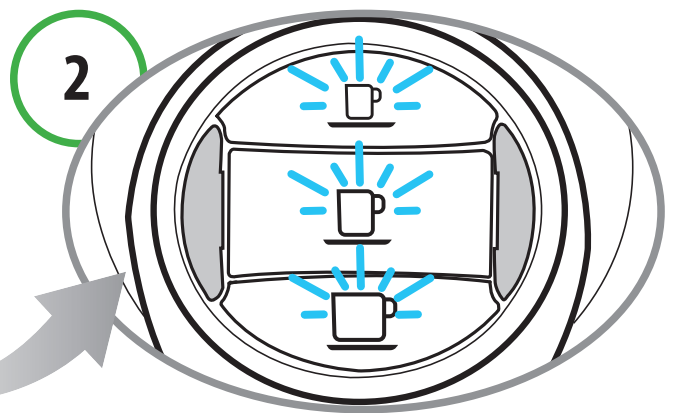

Die Tasten (**Espresso**, **Großer Kaffee** und **Filterkaffee**) blinken gleichzeitig; die Maschine ist in der Heizphase. Wenn die Tasten dauerhaft leuchten, ist die Maschine betriebsbereit.

Entkalkungssignal

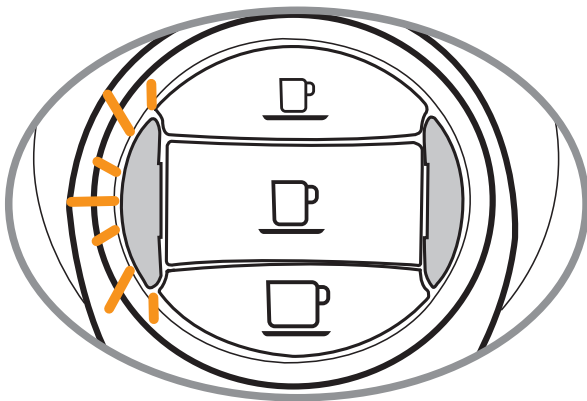

Wenn die **Entkalkungsanzeige** ORANGE blinkt und die Maschine 3 akustische Signale abgibt, sollte ein Entkalkungszyklus durchgeführt werden (siehe Kap. 9).

Aufheizen

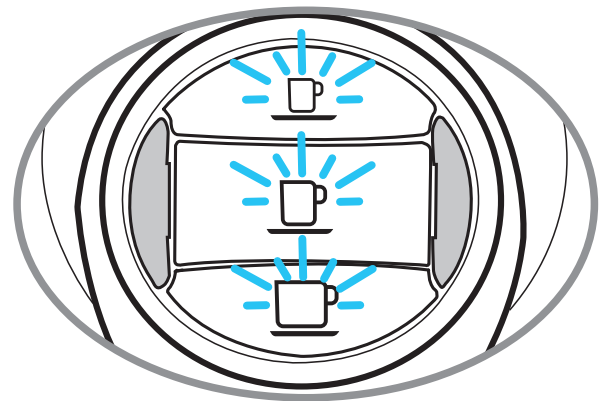

Die Tasten (**Espresso**, **Großer Kaffee** und **Filterkaffee**) blinken gleichzeitig.

Wenn während des Betriebs das Wasser zu Ende geht

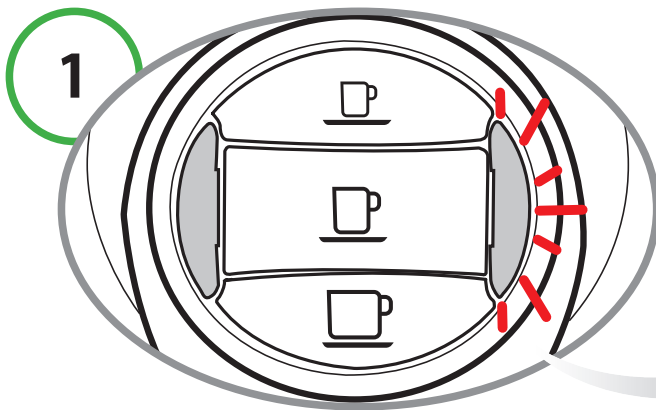

Blinkt die **Multifunktionsanzeige** ROT und gibt die Maschine erst 3 Signaltöne und dann einen intermittierenden Signalton ab, ist der Wassertank leer.

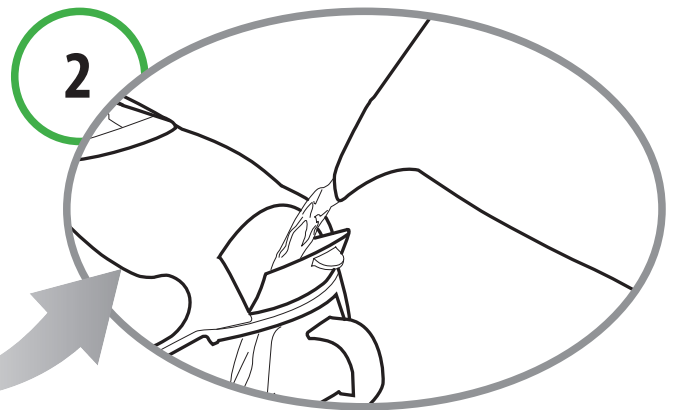

Den Wassertank mit frischem Wasser füllen (ohne Kohlensäure).

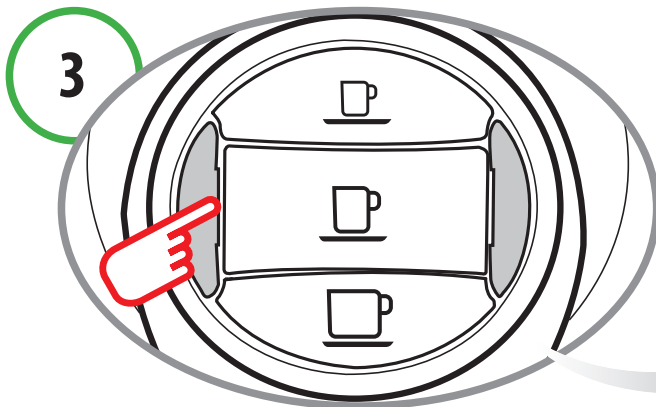

Eine der Kaffeetasten (**Espresso**, **Großer Kaffee** oder **Filterkaffee**) drücken. Warten, bis die Maschine den Befüllungszyklus der Wasserleitungen abgeschlossen hat.

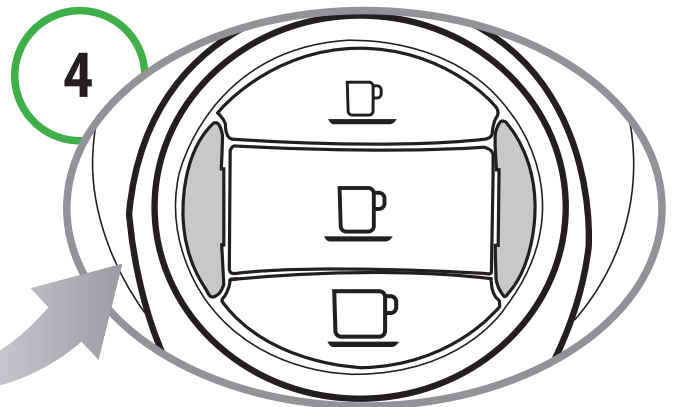

Wenn die Tasten dauerhaft leuchten, ist die Maschine betriebsbereit.

Wenn der Hebel angehoben wird



ACHTUNG!
Wird der Hebel unzeitig während des Abgabe eines Produktes gedrückt, können Heißwasserspritzer gesprüht werden.
Verbrennungsgefahr!

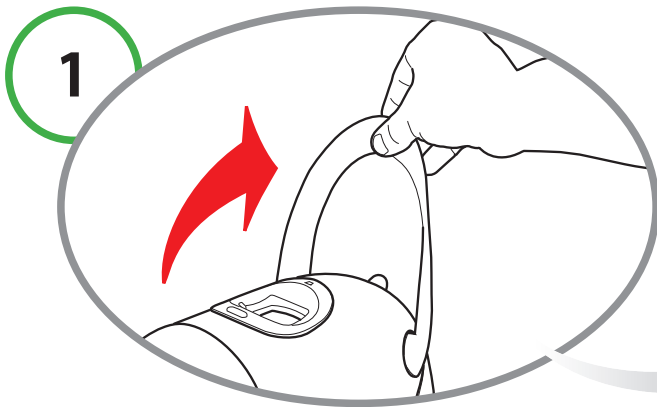

Wenn der Hebel während der Ausgabe eines Produkts nach oben gedrückt wird.

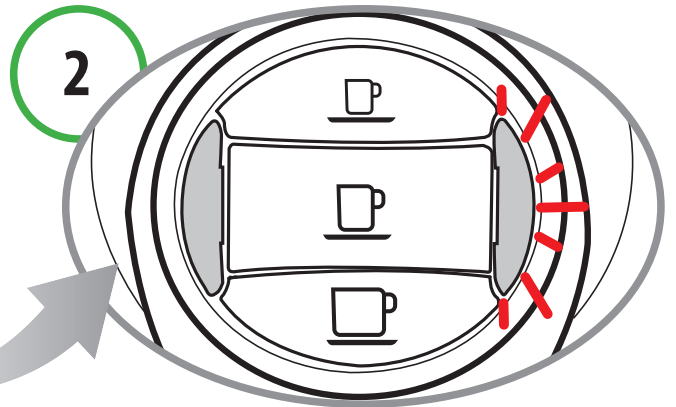

Die **Multifunktionsanzeige** blinkt ROT und ein intermittierendes akustisches Signal ertönt. Die Ausgabe wird sofort unterbrochen.



Den Hebel schließen.

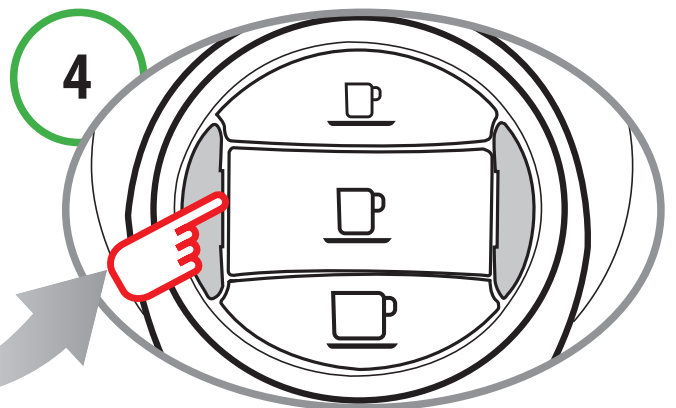

Eine Taste drücken, um den Alarm zurückzusetzen.
Die Maschine ist betriebsbereit.

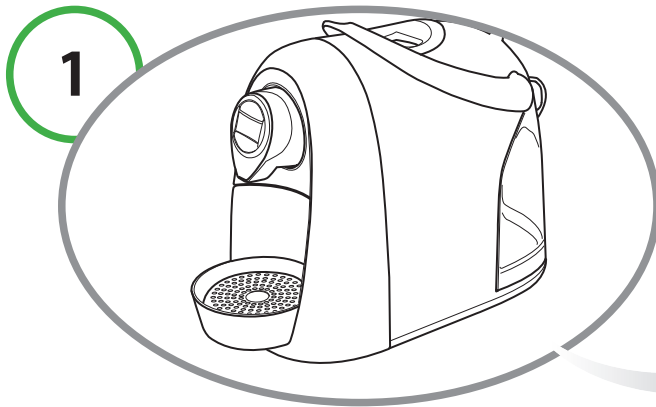

Die Maschine kann so eingestellt werden, dass die Kaffeetassen oder Espressotassen richtig benutzt werden.

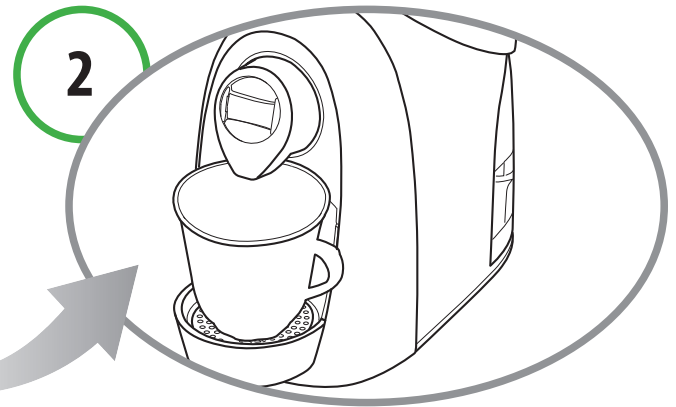

Am Anfang ist die Maschine auf die Benutzung von Kaffeetassen eingestellt.

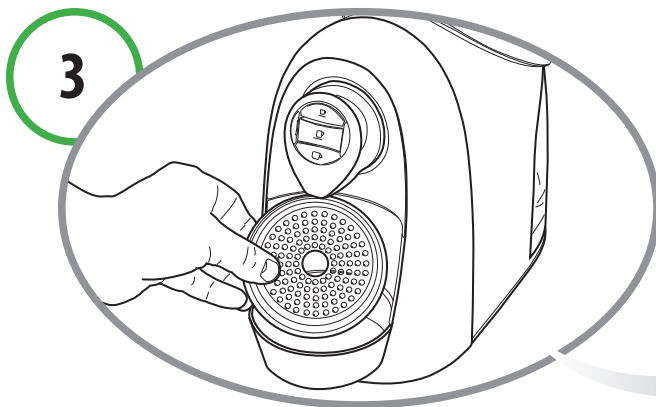

Wenn Espressotassen benutzt werden, muss das Gitter über der Abtropfschale angehoben und umgedreht werden.

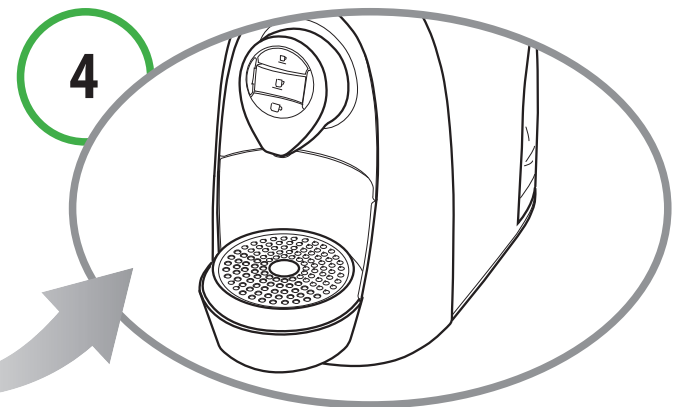

Das umgedrehte Gitter muss auf die Abtropfschale gesetzt werden.

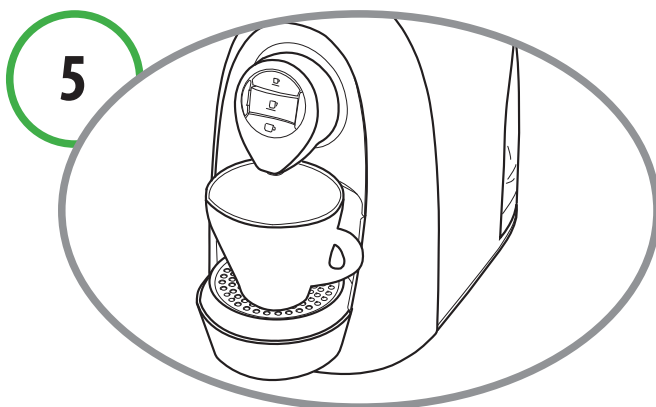

Auf diese Weise kann man die Tässchen verwenden und ein besseres Ergebnis bekommen.



Den Hebel hochstellen und das Kapselfach öffnen.

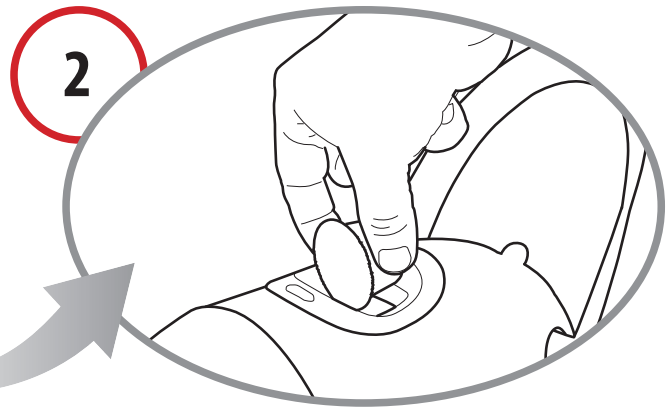

Die Kapsel mit leichtem Druck einlegen.

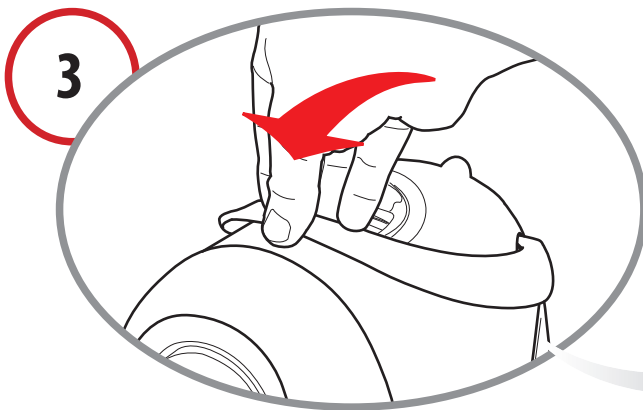

Den Hebel kräftig schließen.

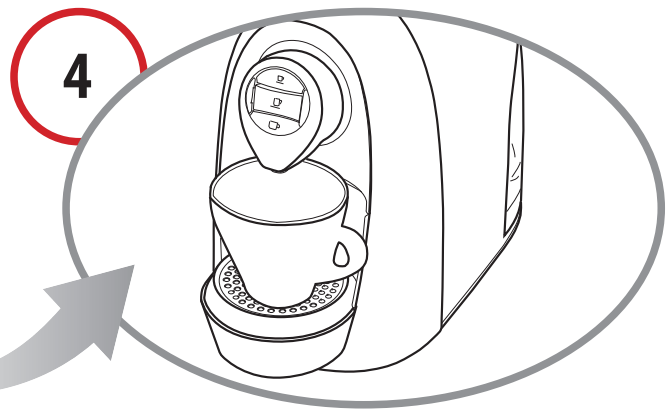

Eine Kaffee- oder Espressotasse unter den Kaffeeauslauf stellen.

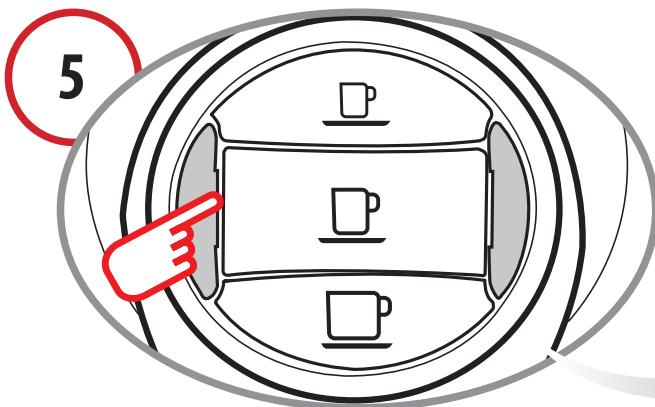

Nur einmal die Taste für den gewünschten Kaffee drücken.

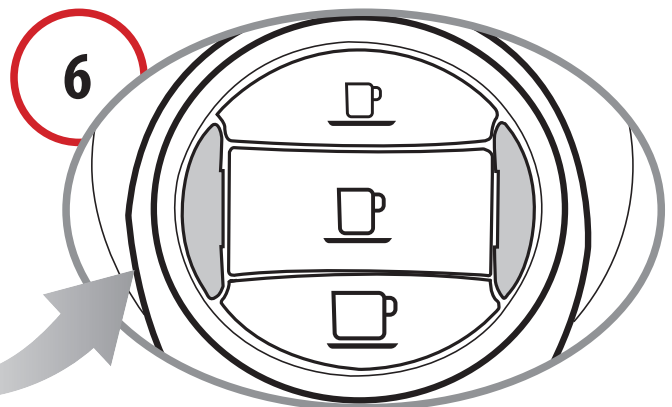

Die Taste des gewünschten Kaffees blinkt. Die Ausgabe stoppt, wenn die programmierte Menge erreicht ist, und die Maschine gibt einen Signalton ab.

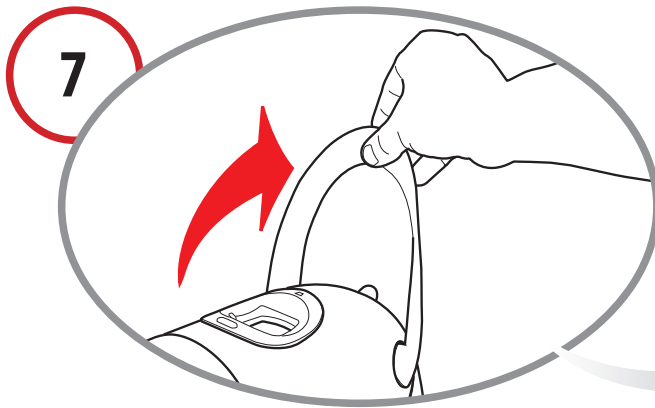

Den Hebel anheben, um die Kapsel in den vorgesehenen Behälter auszuwerfen.

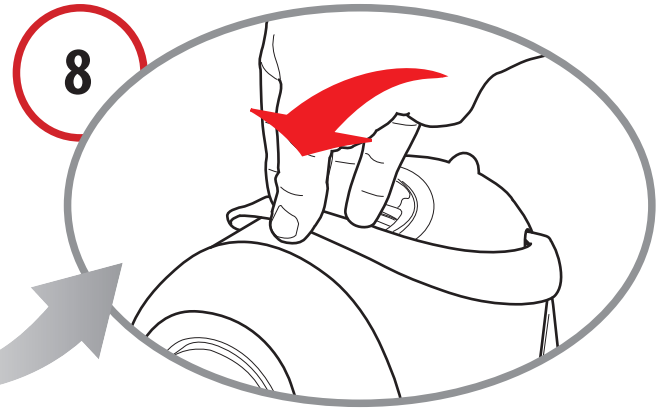

Den Hebel schließen.



HINWEIS:

Die auszugebende Kaffeemenge kann je nach persönlicher Vorliebe und der Größe der verwendeten Kaffee- oder Espressotassen neu programmiert werden. Zur Neuprogrammierung siehe Kapitel 7.

6 Zubereitung von anderen Getränken

Es sind auch Kapseln für die Zubereitung von **Tee, Kamillentee, Filterkaffee usw. lieferbar**. Für ihre Zubereitung laut Beschreibung im vorangehenden Kapitel vorgehen; bei Erreichen von Punkt 5 die Taste „**Filterkaffee**“ drücken.

Für die Zubereitung von Getränken mit **Malzkaffee kapseln, von Kakaogetränken usw.**

laut Beschreibung im vorangehenden Kapitel vorgehen; in Punkt 5 die Taste „**Espresso**“ oder „**Großer Kaffee**“ drücken, je nach gewünschter Menge.



HINWEIS:

In den Maschinenleitungen können Spuren des zuletzt ausgegebenen Produkts zurückbleiben. Um den Geschmack des Getränks nach Möglichkeit zu bewahren, sollte vor dem Wechsel zu einem anderen Produkt eine kurze Spülung vorgenommen werden; die Spülung erfolgt durch Ausgabe eines Kaffees ohne Einlegen einer Kapsel.

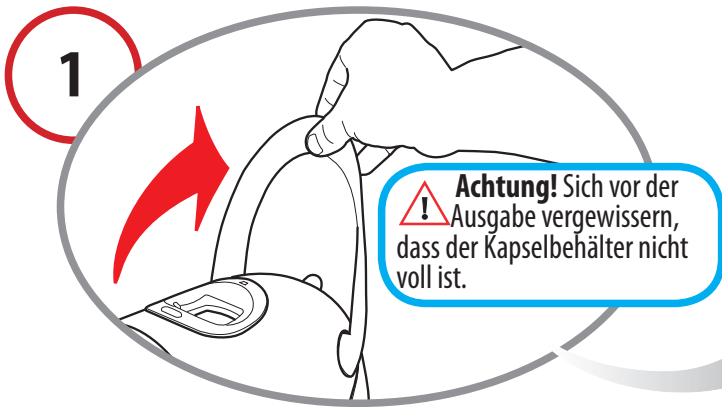

Den Hebel hochstellen und das Kapselfach öffnen.

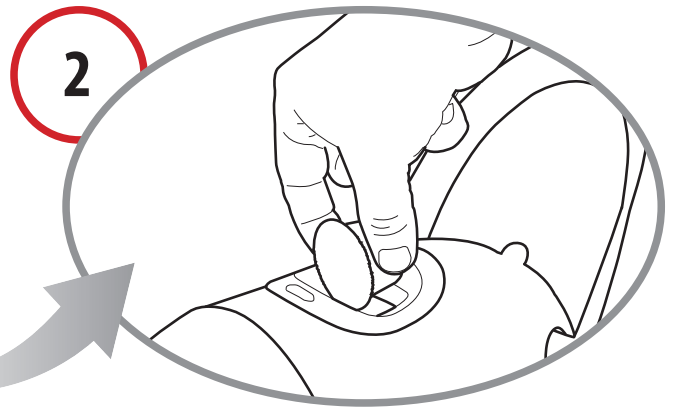

Die Kapsel mit leichtem Druck einlegen.

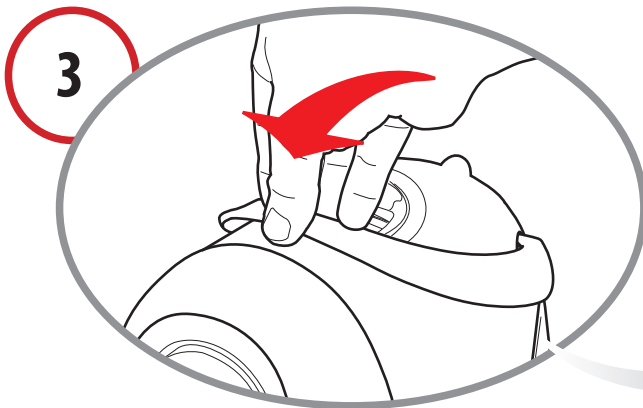

Den Hebel kräftig schließen.

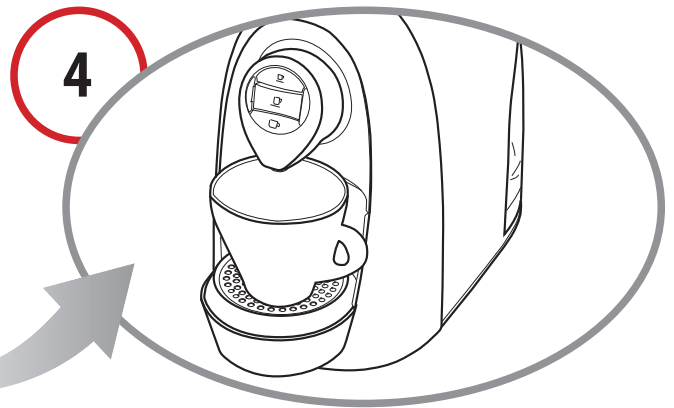

Eine Kaffee- oder Espressotasse unter den Kaffeeauslauf stellen.

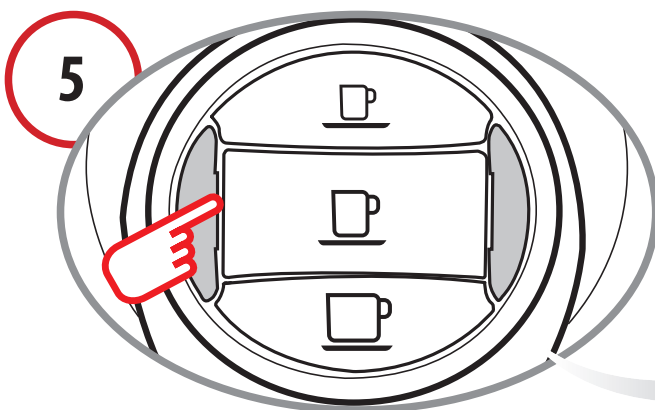

Die Taste für den gewünschten Kaffee **anhaltend drücken**.

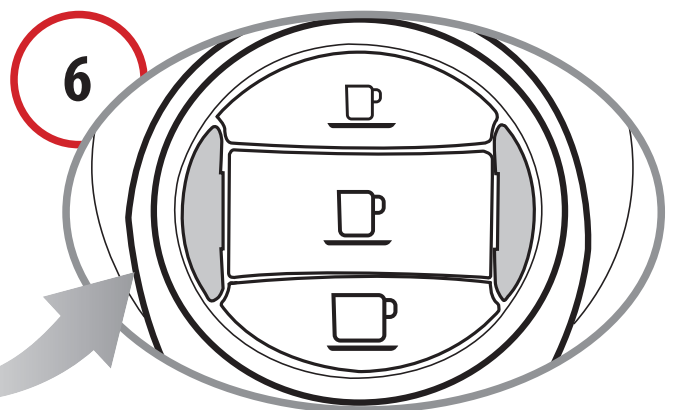

Wenn die gewünschte Kaffeemenge pro Tasse erreicht ist, die Taste loslassen. Damit ist die Taste programmiert. Zum Umprogrammieren einer gerade programmierten Taste oder zum Programmieren einer anderen Taste die Schritte wiederholen.

Die Kaffeeausgabe kann auf maximal 250 ml programmiert werden.

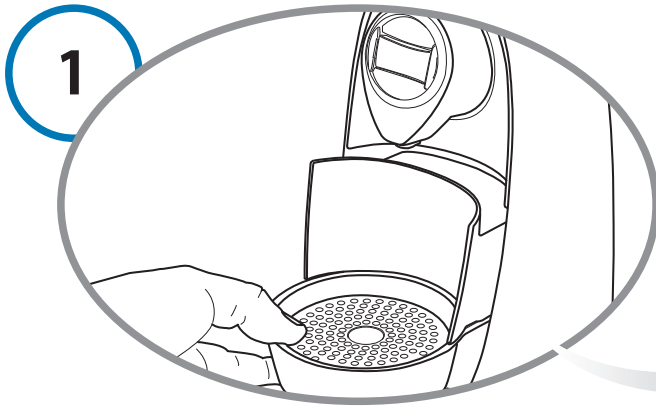

1 Die Abtropfschale und den Behälter für gebrauchte Kapseln entnehmen.

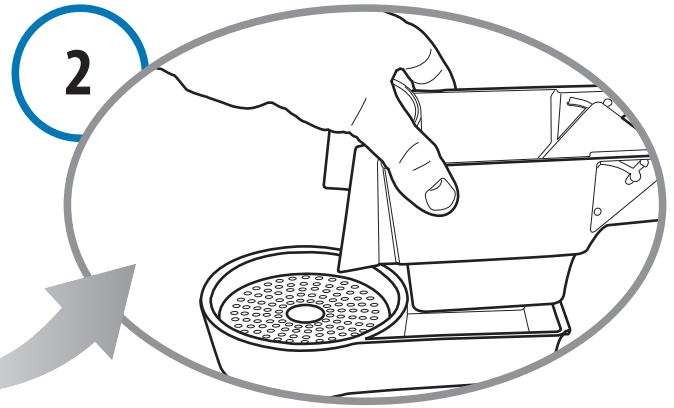

2 Den Behälter für gebrauchte Kapseln anheben, leeren und ausspülen.

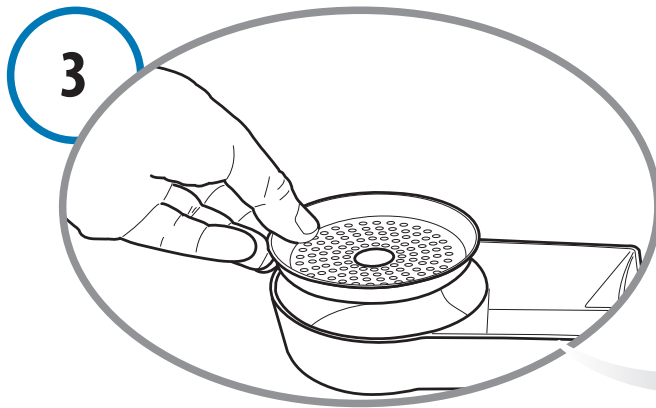

3 Das Gitter abnehmen. Die Tropfschale leeren und mit frischem Wasser ausspülen.

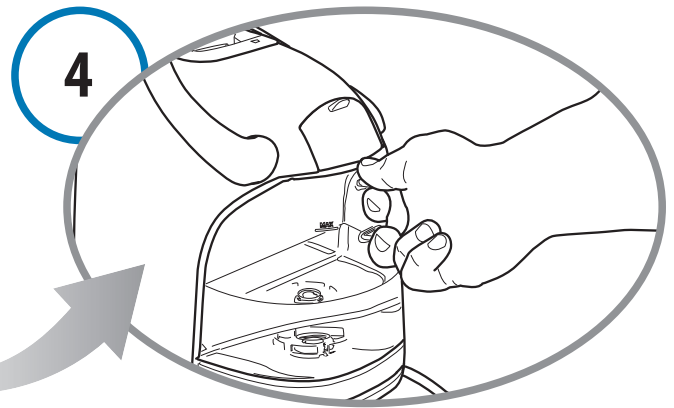

4 Den Wassertank herausnehmen. Den Tank entleeren und ausspülen. Der Wassertank darf NICHT in der Spülmaschine gewaschen werden.



Die Geräteoberfläche mit einem weichen Tuch und Neutralreiniger reinigen. Richten Sie zum Reinigen keinen Wasserstrahl direkt auf das Gerät.



Die Plastikteile der Maschine dürfen nicht in der Spülmaschine gewaschen werden.

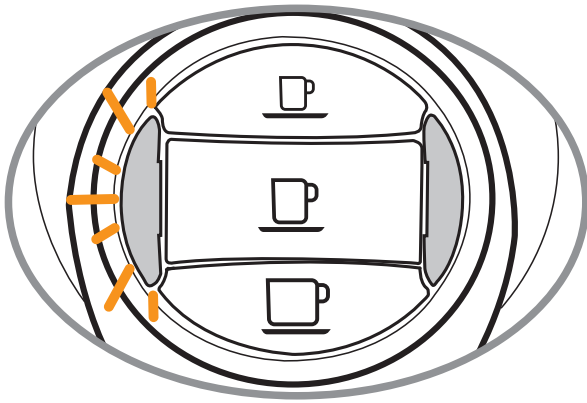

Die Maschine besitzt ein intelligentes Programm, das kontrolliert, wie viel Wasser für die Ausgabe der Produkte verbraucht wird. Auf Grund dieser Messung kann es dem Benutzer Hinweise darauf geben, wann die Maschine einen Entkalkungszyklus benötigt. Die einzelnen Hinweise werden in Kapitel 3 behandelt.

Wenn die **Entkalkungsanzeige** ORANGE blinkt und die Maschine 3 akustische Signale abgibt, sollte ein Entkalkungszyklus durchgeführt werden (siehe Kap. 9).



Lesen Sie **AUFMERKSAM** die Gebrauchsanweisung auf der Verpackung des Entkalkers durch. Den Kontakt mit den Augen, der Haut und den Oberflächen der Maschine vermeiden. Während der Entkalkung darf die Maschine nicht ausgeschaltet und der Wahlhebel nicht angehoben werden. Während dieses Vorgangs muss eine Person zugegen sein.

Keinen Essig verwenden: er kann Ihre Maschine beschädigen!

Wir empfehlen die Entkalkungsflüssigkeit Caffita System, die speziell auf die technischen Eigenschaften der Maschine abgestimmt ist und absolute Sicherheit für den Verbraucher gewährleistet. Die Entkalkerflüssigkeit muss gemäß Herstellerangaben bzw. den im Bestimmungsland geltenden Vorschriften entsorgt werden.

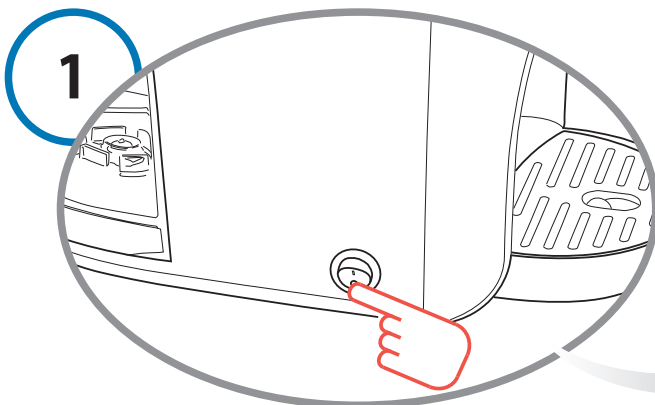

Die Maschine ausschalten.

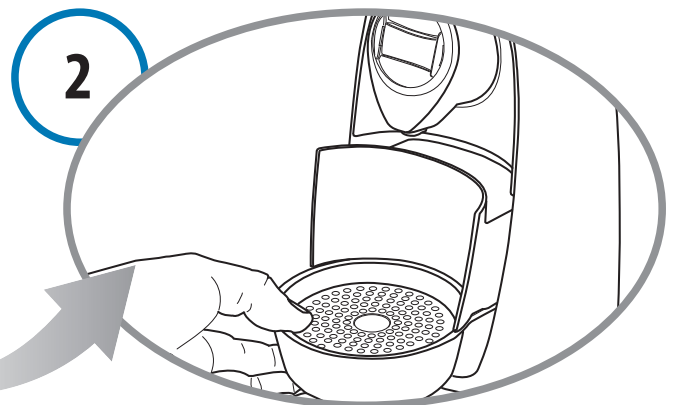

Den Behälter für gebrauchte Kapseln und die Abtropfschale leeren und ausspülen.

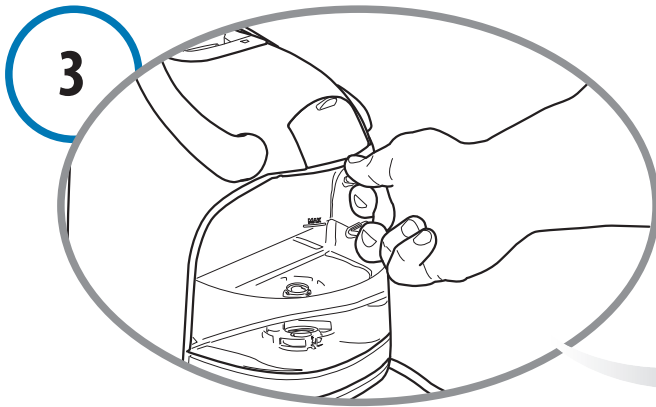

Den Wassertank herausnehmen und leeren.

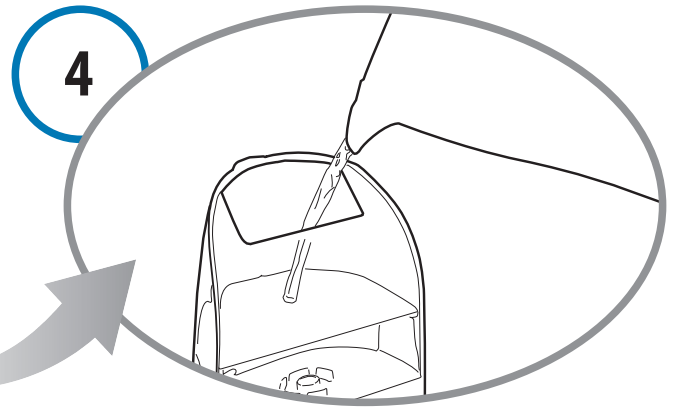

Die Entkalkerflüssigkeit gemäß Verpackungsangaben mit Wasser vermischen und die Lösung in den Tank gießen.

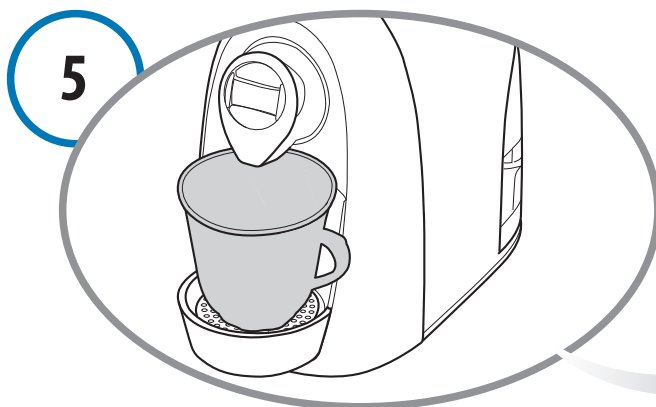

Einen mindestens 250 ml fassenden Behälter unter den Kaffeeauslauf stellen.

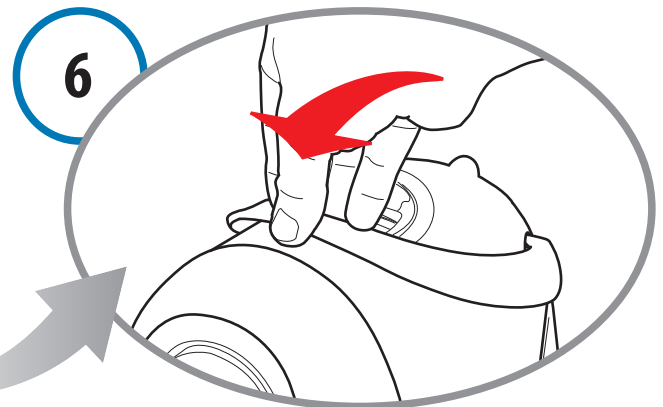

Prüfen, ob der Hebel nach unten gestellt ist.

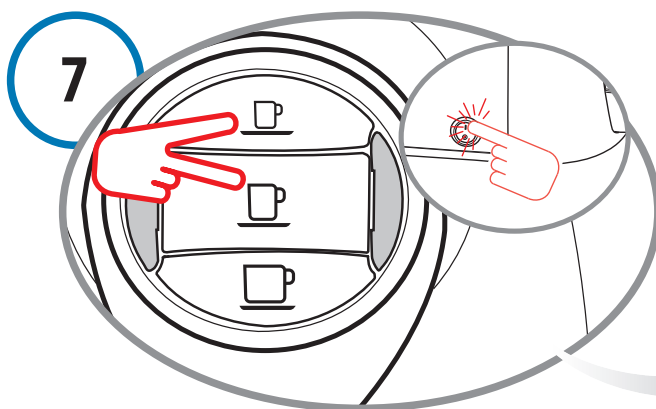

Die Tasten (**Espresso** und **Großer Kaffee**) drücken und gleichzeitig die Maschine mit dem Hauptschalter einschalten.

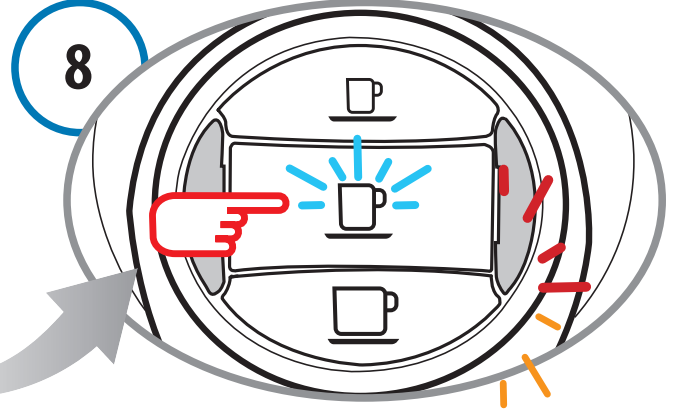

Gleichzeitig mit der Taste **Großer Kaffee** blinkt abwechselnd auch die **Multifunktionsanzeige** (ROT und ORANGE). Zum Starten des Entkalkungszyklus die Taste **Großer Kaffee** drücken.

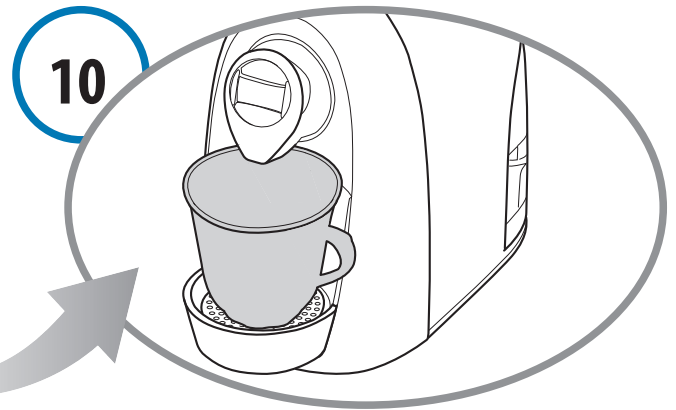
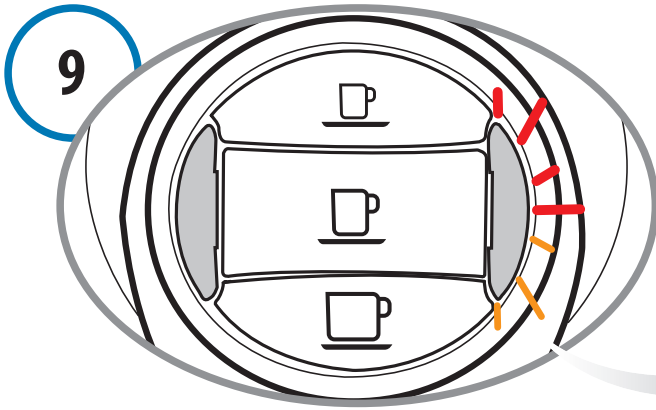

Die Maschine gibt in Abständen Entkalkerflüssigkeit ab (**5 Abgaben unterbrochen von einer 10-Minuten-Pause für eine Gesamtdauer von ca. 45 Minuten**). Während dieser Phase, **in der keine Tasten gedrückt werden dürfen**, blinkt die **Multifunktionsanzeige** abwechselnd (ROT und ORANGE).

Wenn der Behälter voll ist, leeren.

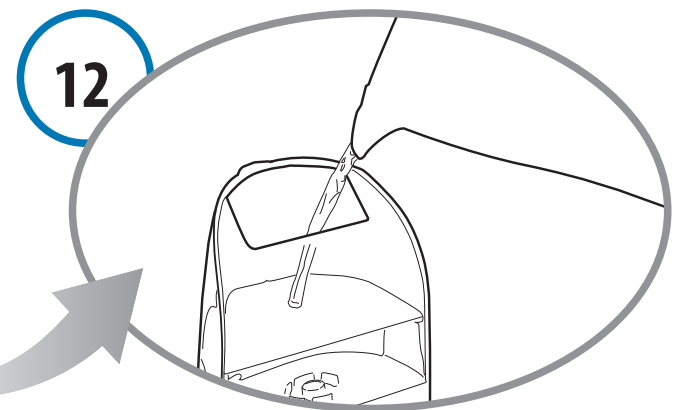
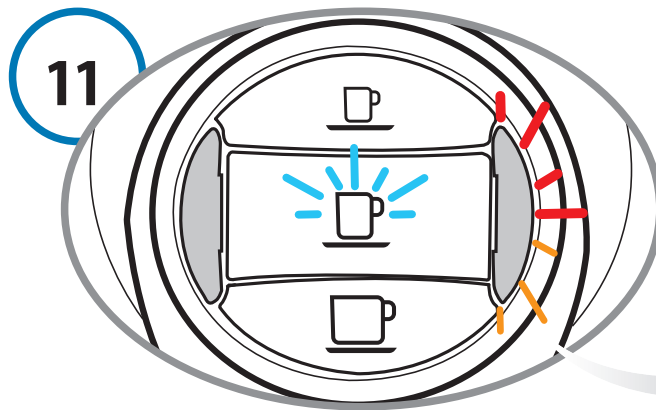

Nach Abschluss des Zyklus blinkt zusammen mit der Taste **Großer Kaffee** abwechselnd auch die **Multifunktionsanzeige** (ROT und ORANGE).

Den Wassertank gründlich ausspülen und mit frischem Leitungswasser füllen.

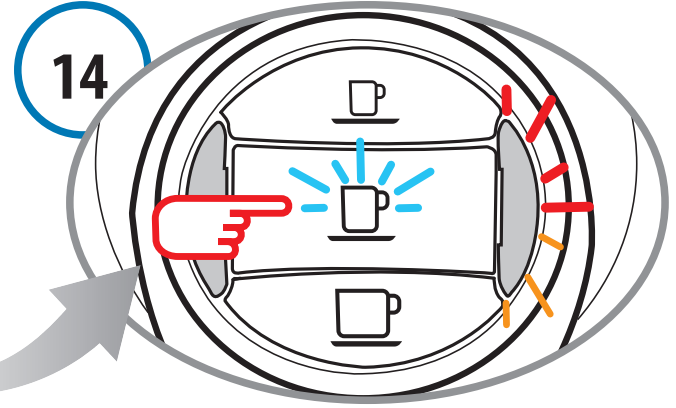
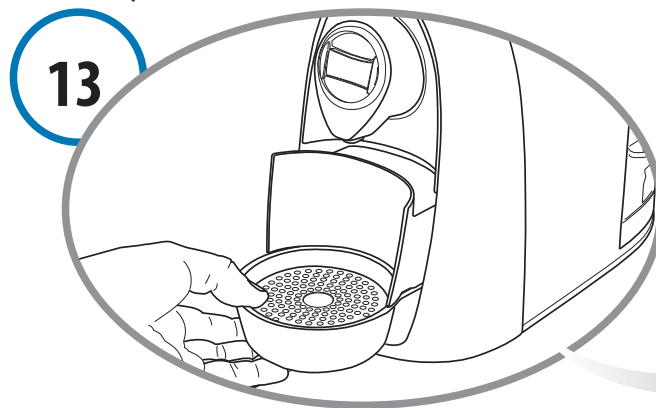

Den Behälter für gebrauchte Kapseln und die Abtropfschale leeren und ausspülen.

Gleichzeitig mit der Taste **Großer Kaffee** blinkt abwechselnd auch die **Multifunktionsanzeige** (ROT und ORANGE). Zum Starten des Entkalkungszyklus die Taste **Großer Kaffee** drücken.

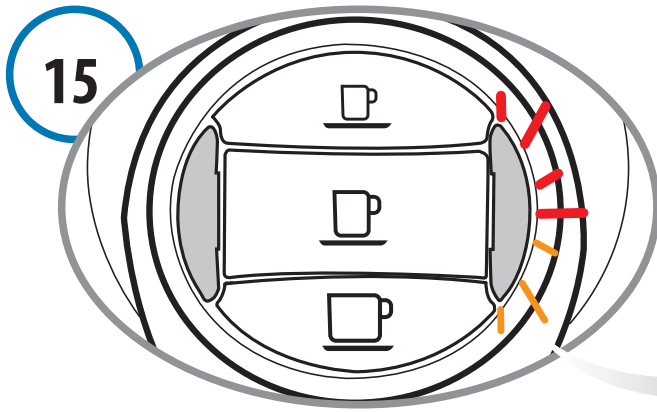

Die Maschine gibt Spülwasser ab. Während dieser Phase blinkt die **Multifunktionsanzeige** abwechselnd (2 Mal ROT und 2 Mal ORANGE).

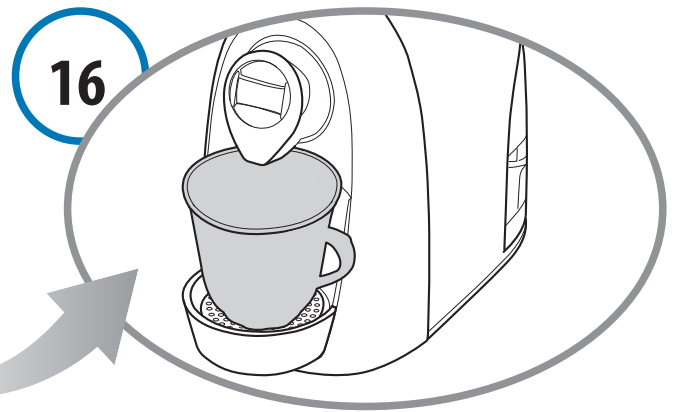

Wenn der Behälter voll ist, leeren.

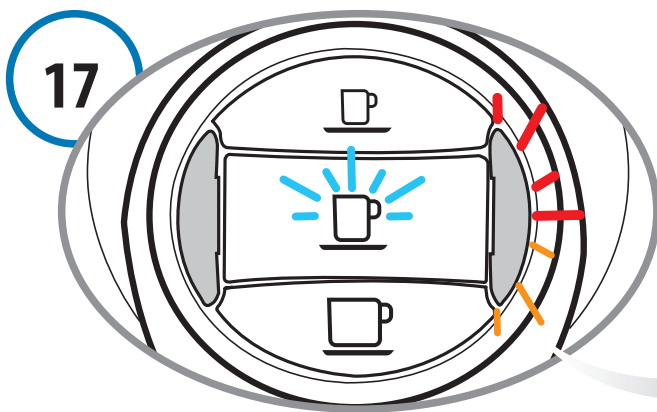

Nach Abschluss des Nachspülzyklus blinkt zusammen mit der Taste **Großer Kaffee** abwechselnd auch die **Multifunktionsanzeige** (ROT und ORANGE). Die Maschine gibt einen Signalton ab.

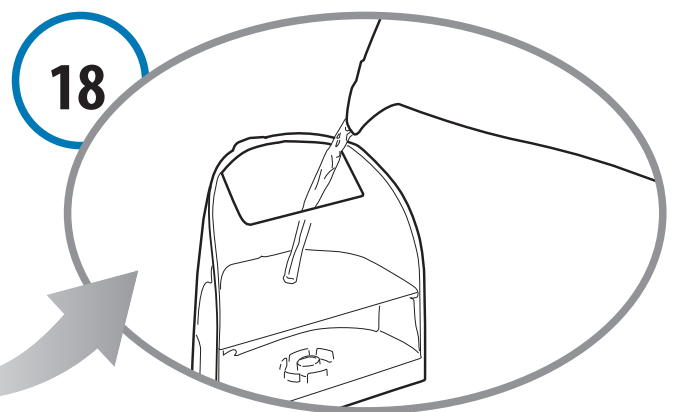

Den Wassertank gründlich ausspülen und mit frischem Leitungswasser füllen.

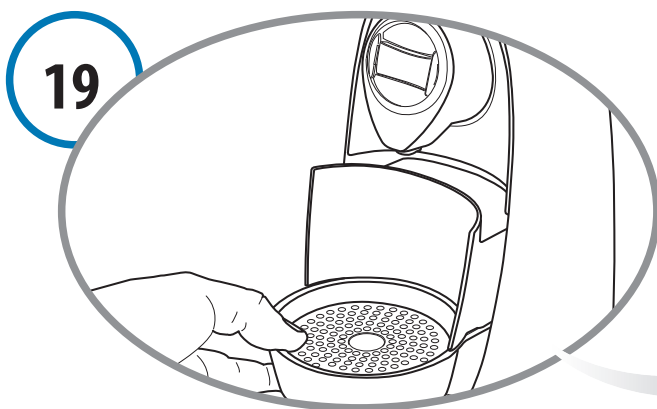

Den Behälter für gebrauchte Kapseln und die Abtropfschale leeren und ausspülen.

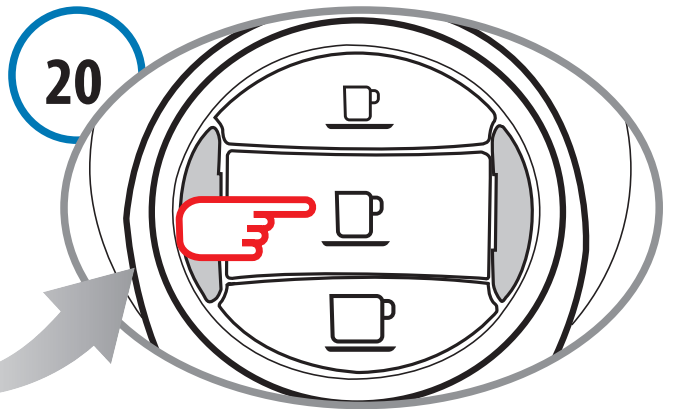





Die Taste **Großer Kaffee** drücken, um den Zyklus zu verlassen.



Die Geräteoberfläche mit einem weichen Tuch und Neutralreiniger reinigen.

PROBLEM	URSACHE	ABHILFE
- Es wird kein Kaffee ausgegeben.	- Der Wassertank ist leer, die Multifunktionsanzeige leuchtet ROT.	- Den Wassertank mit frischem Wasser füllen. Eine der Kaffeeausgabetaasten drücken, um auch die Wasserleitungen zu füllen.
- Der Kaffee ist nicht heiß genug.	- Kaffeetassen / Espressotassen nicht vorgewärmt. - Maschine verkalkt.	- Kaffeetasse / Espressotasse vorwärmen. - Entkalken.
- Der Hebel lässt sich nicht nach unten stellen.	- Der Behälter für gebrauchte Kapseln ist voll. - Kapsel in der Maschine verklemmt.	- Den Behälter für gebrauchte Kapseln leeren. - Die gebrauchte Kapsel herausnehmen.

11 Technische Daten

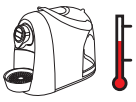
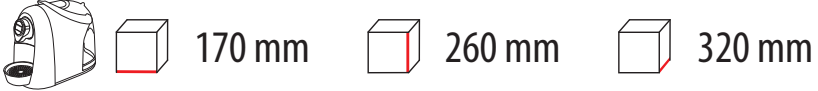
	Bitte auf das Typenschild unter dem Gerät Bezug nehmen.
P	Max. 15 bar
	< 70dB A
	ca. 4 kg
	1,2 liter
	Raumtemperatur: 10°C ÷ 40°C
	170 mm 260 mm 320 mm

Die Materialien und Teile, die mit Lebensmitteln in Berührung kommen, entsprechen den Bestimmungen der europäischen Verordnung 1935/2004.



www.caffitaly.com

IB0400100 - Rev.03 del 28-01-11