

elco

NEXTRON

MONOBLOCK BURNERS

250 - 11200 kW



MAIN CHARACTERISTICS OF THE RANGE

Combustion

Unique and efficient

Developed and improved by ELCO R&D department, the Free Flame technology is a unique combustion process. This ELCO technology is capable to reach the NO_x levels required by the most severe standards for all types of combustion chambers, whether they are 3-pass or reverse pass boilers.



Design

Smooth and integral

The original design of NEXTRON® range is the result of a successful integration between burner and ELCO technologies.

NEXTRON® burners are able to perfectly integrate themselves in any installation and professionals will appreciate the innovative construction that ease maintenance.



Switch cabinet

Built-in and modular

All the NEXTRON® burners feature integrated switch cabinet, the ISC System, with modular concept for control devices and accessories, including:

- adjusting and safety control box
- EMC protected power circuit of fan motor
- display with command keyboard in front of the panel

The ISC System houses options and accessories, such as the power regulator and the frequency inverter (Variatron), and customizes each burner according to the installation needs.



Communication

User-friendly and universal

The adjusting and reading of the available information about the NEXTRON® operation are possible through the MDE2 System, a display with a 5-buttons keyboard, by using pictograms and numerical data. This user-friendly language assures quick reading and total understanding, as ever before.



Acoustic

Comfort and compact

The NEXTRON® burner range offers a high acoustic comfort thanks to the Low Noise System. The unique air intake channel is carefully designed to achieve an acoustic level significantly lower than 80 dB(A) up to 10 MW. This integrated and patented system on all NEXTRON® burners is definitely a good replacement of the traditional bulky sound proofing box.

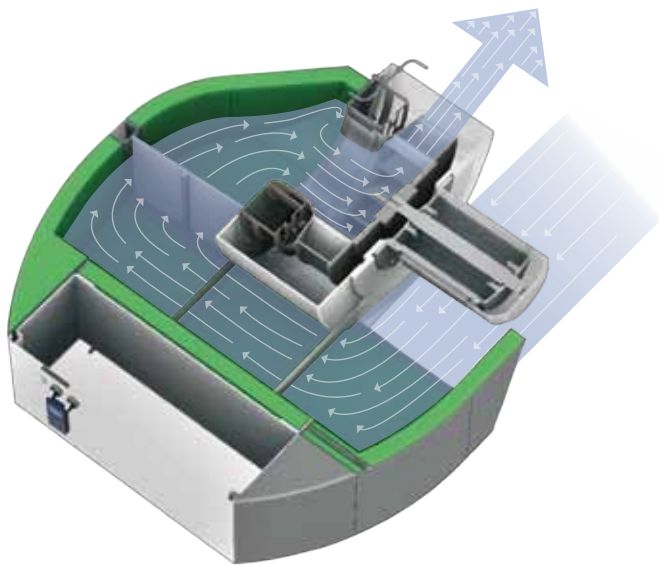

Maintenance

Simple and time saving

The maintenance of the NEXTRON® burner can be easily carried out thanks to a large opening of the above left side of its housing that offers an easy access to the whole combustion components.

Thanks to the RTC System, the combustion components find again exactly the original position after the maintenance operations. Year after year, the RTC System grants high quality and reliable combustion on the NEXTRON® range.



COMBUSTION CONTROL MAIN FEATURES

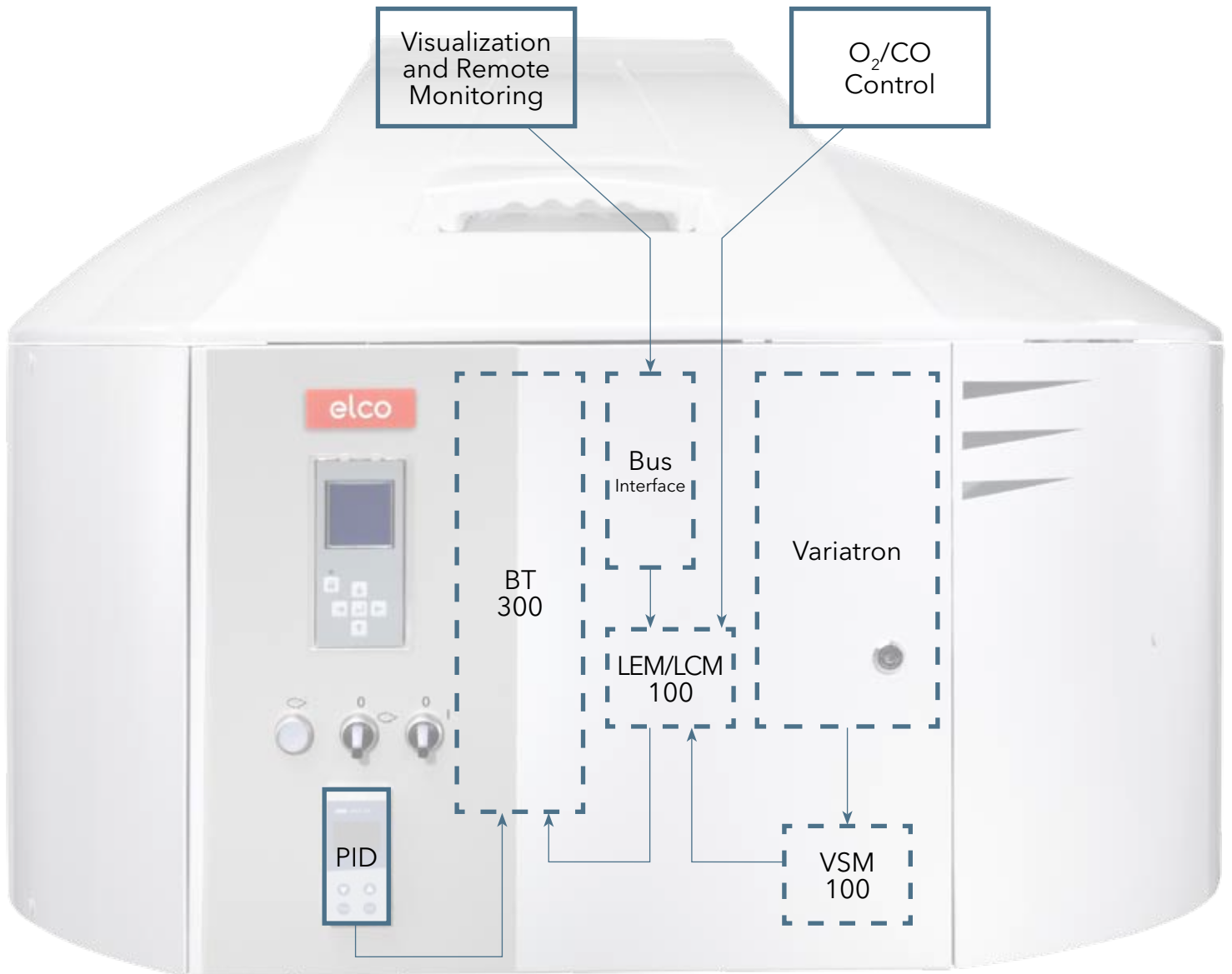

Electronic control

Integrated and versatile

The option "load controller" is in the form of a regulator mounted on the door of the switch cabinet and connected directly to the control box.

With the help of three integrated modules in their cabinet, the NEXTRON 6 to 9 are able to:

- adjust the fan speed to the required flame power;
- monitor the combustion quality by analyzing the concentration of O₂ and CO in the flue gas;
- communicate remotely via an Ethernet network, as Modbus, Profibus or Ethernet.

DESIGNATION OF NEXTRON COMPONENTS

Body

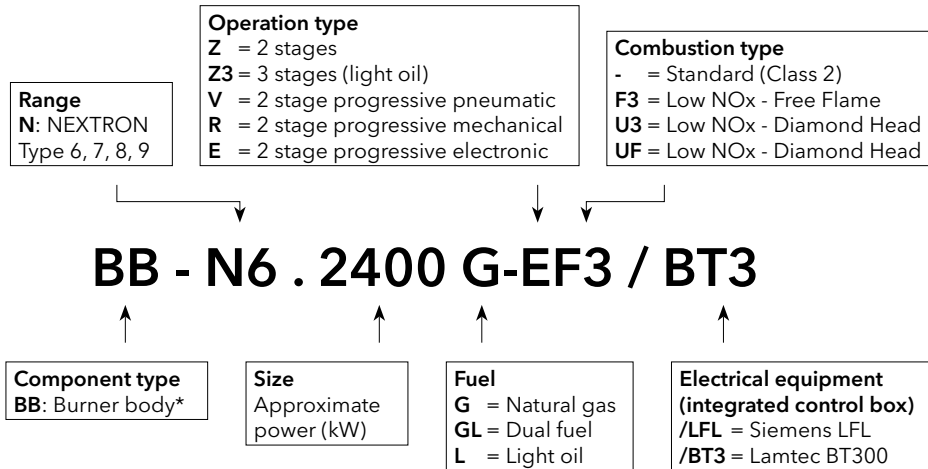

Combustion head

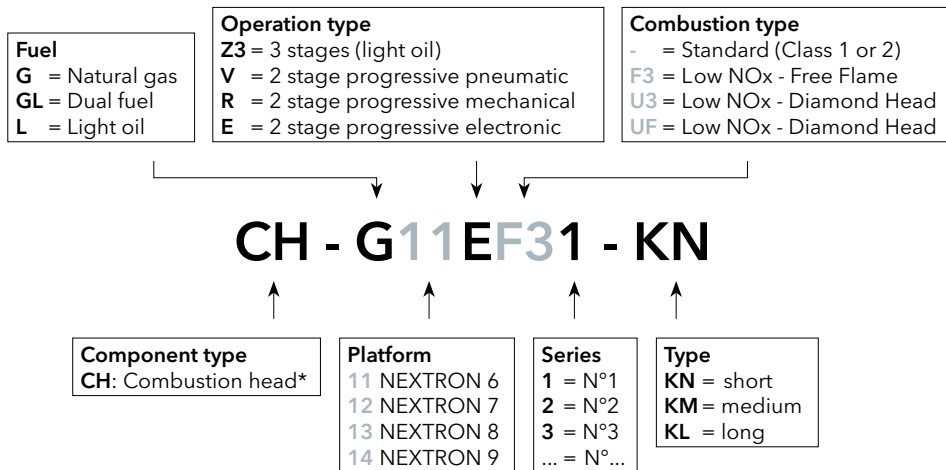

Gas train

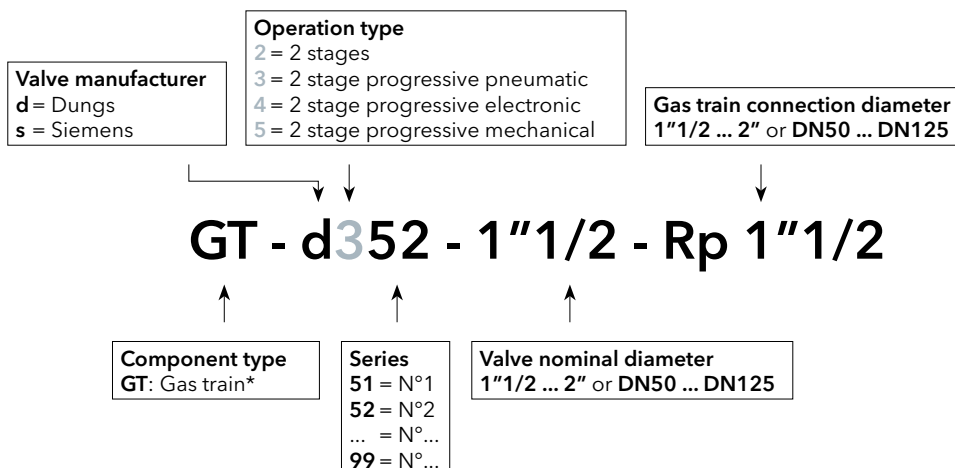

* for invoice purposes only

TECHNICAL DATA | GAS RANGE

NEXTRON 6 - 7 G-E/G-V/G-R

Low NOx Class 2 (< 120 mg/kWh)

	N6.2400 G-E / G-V / G-R	N6.2900 G-E / G-V / G-R	N7.3600 G-E / G-V / G-R	N7.4500 G-E / G-V / G-R
Burner output [kW]	390 - 2500	400 - 3000	580 - 4100	680 - 5000
Gas pressure [mbar]	50 ... 300	50 ... 300	50 ... 300	50 ... 300
Fan motor	400 V - 50/60 Hz - 3 kW	400 V - 50/60 Hz - 4 kW	400 V - 50/60 Hz - 5,5 kW	400 V - 50/60 Hz - 7,5 kW
Auxiliary voltage	1NPE AC 230 V - 50 Hz	1NPE AC 230 V - 50 Hz	1NPE AC 230 V - 50 Hz	1NPE AC 230 V - 50 Hz
Power supply	3NPE AC 400 V - 50 Hz	3NPE AC 400 V - 50 Hz	3NPE AC 400 V - 50 Hz	3NPE AC 400 V - 50 Hz
Acoustic level [dB(A)]	< 70	< 71	< 74	< 75,5

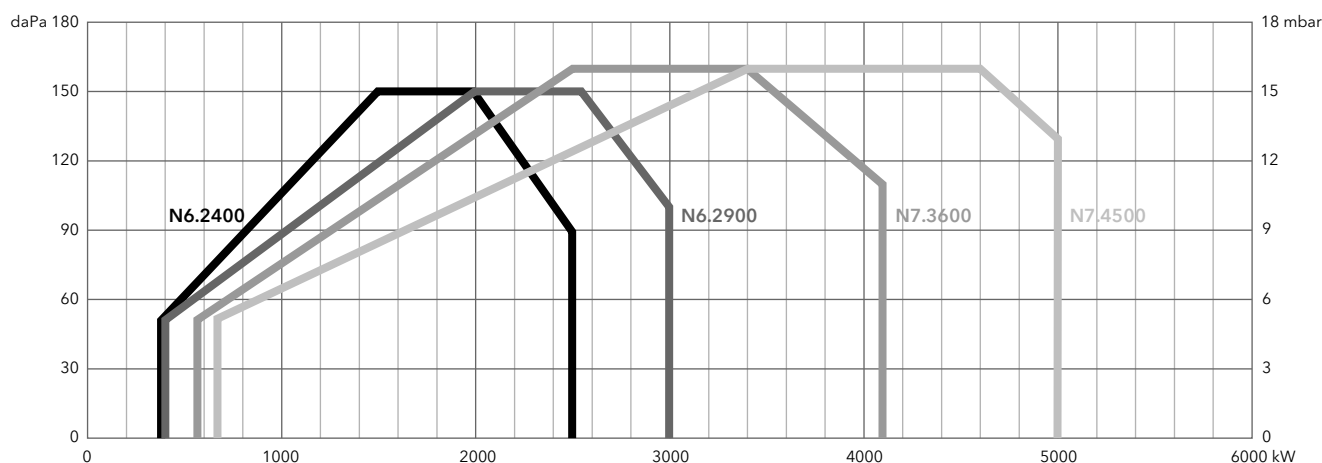

NEXTRON 8 - 9 G-E

Low NOx Class 2 (< 120 mg/kWh)

	N8.5800 G-E	N8.7100 G-E	N9.8700 G-E	N9.10400 G-E
Burner output [kW]	740 - 6570	800 - 7800	880 - 9200	960 - 11200
Gas pressure [mbar]	100 ... 500	100 ... 500	100 ... 500	100 ... 500
Fan motor	400 V - 50/60 Hz - 11 kW	400 V - 50/60 Hz - 15 kW	400 V - 50/60 Hz - 18,5 kW	400 V - 50/60 Hz - 22 kW
Auxiliary voltage	1NPE AC 230 V - 50 Hz	1NPE AC 230 V - 50 Hz	1NPE AC 230 V - 50 Hz	1NPE AC 230 V - 50 Hz
Power supply	3NPE AC 400 V - 50 Hz	3NPE AC 400 V - 50 Hz	3NPE AC 400 V - 50 Hz	3NPE AC 400 V - 50 Hz
Acoustic level [dB(A)]	< 77,5	< 78	< 80	< 82

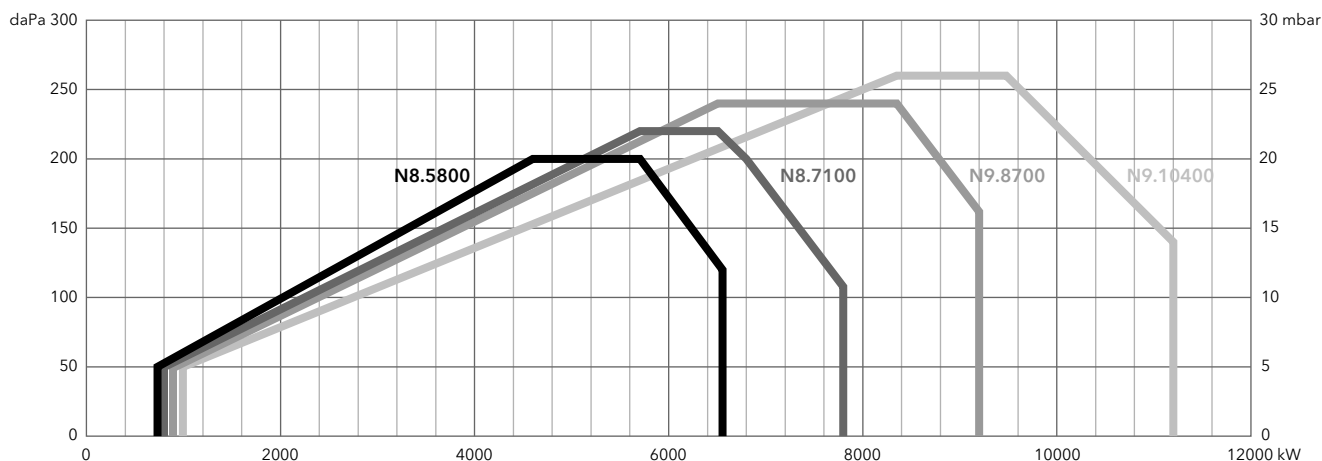

TECHNICAL DATA | GAS RANGE

NEXTRON 6 - 7 G-EF3/G-VF3

Low NOx Class 3 (< 80 mg/kWh)

	N6.2400 G-EF3 / G-VF3	N6.2900 G-EF3 / G-VF3	N7.3600 G-EF3 / G-VF3	N7.4500 G-EF3 / G-VF3
Burner output [kW]	340 - 2300	360 - 2850	500 - 3900	600 - 4200
Gas pressure [mbar]	50 ... 300	50 ... 300	50 ... 300	50 ... 300
Fan motor	400 V - 50/60 Hz - 3 kW	400 V - 50/60 Hz - 4 kW	400 V - 50/60 Hz - 7,5 kW	400 V - 50/60 Hz - 7,5 kW
Auxiliary voltage	1NPE AC 230 V - 50 Hz	1NPE AC 230 V - 50 Hz	1NPE AC 230 V - 50 Hz	1NPE AC 230 V - 50 Hz
Power supply	3NPE AC 400 V - 50 Hz	3NPE AC 400 V - 50 Hz	3NPE AC 400 V - 50 Hz	3NPE AC 400 V - 50 Hz
Acoustic level [dB(A)]	< 69	< 71	< 76	< 74

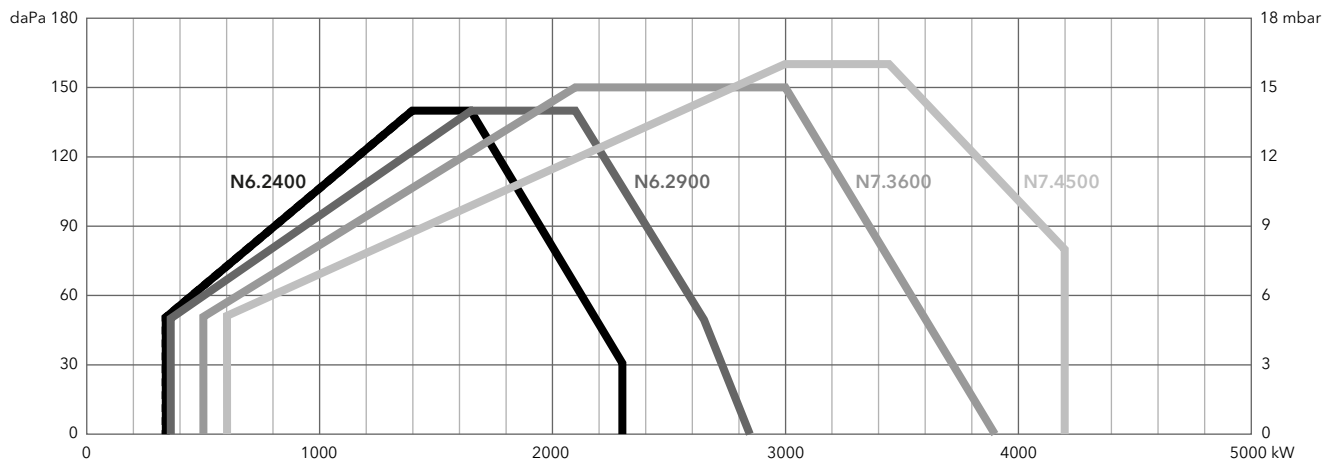

NEXTRON 8 - 9 G-EU3

Low NOx Class 3 (< 80 mg/kWh)

	N8.5800 G-EU3	N8.7100 G-EU3	N9.8700 G-EU3	N9.10400 G-EU3
Burner output [kW]	640 - 5800	700 - 7100	850 - 8530	900 - 10200
Gas pressure [mbar]	50 ... 500	50 ... 500	100 ... 500	100 ... 500
Fan motor	400 V - 50/60 Hz - 11 kW	400 V - 50/60 Hz - 15 kW	400 V - 50/60 Hz - 18,5 kW	400 V - 50/60 Hz - 22 kW
Auxiliary voltage	1NPE AC 230 V - 50 Hz	1NPE AC 230 V - 50 Hz	1NPE AC 230 V - 50 Hz	1NPE AC 230 V - 50 Hz
Power supply	3NPE AC 400 V - 50 Hz	3NPE AC 400 V - 50 Hz	3NPE AC 400 V - 50 Hz	3NPE AC 400 V - 50 Hz
Acoustic level [dB(A)]	< 77,5	< 79,5	< 80	< 82

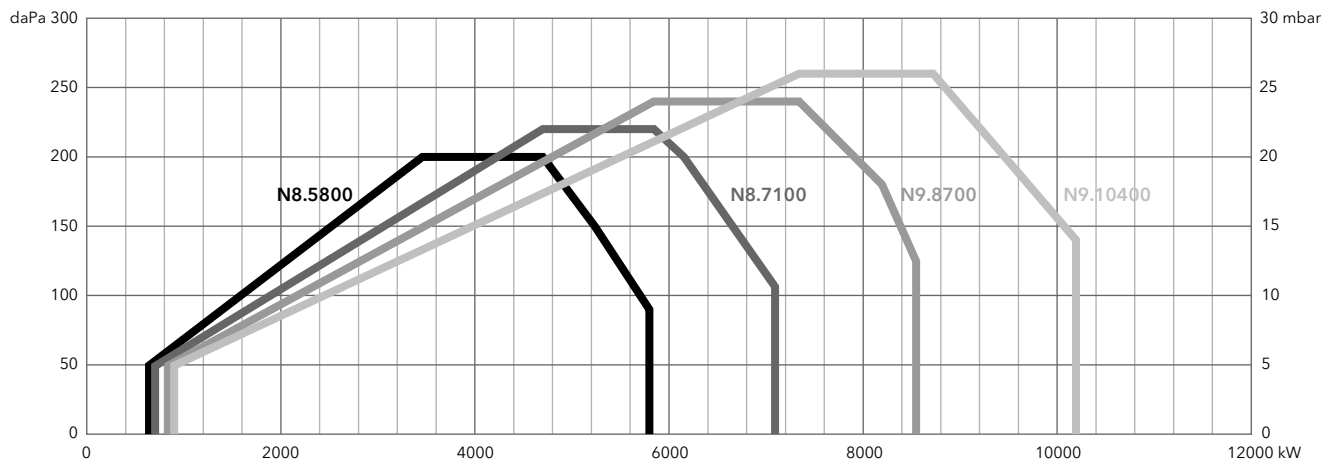

OVERALL DIMENSIONS | GAS RANGE

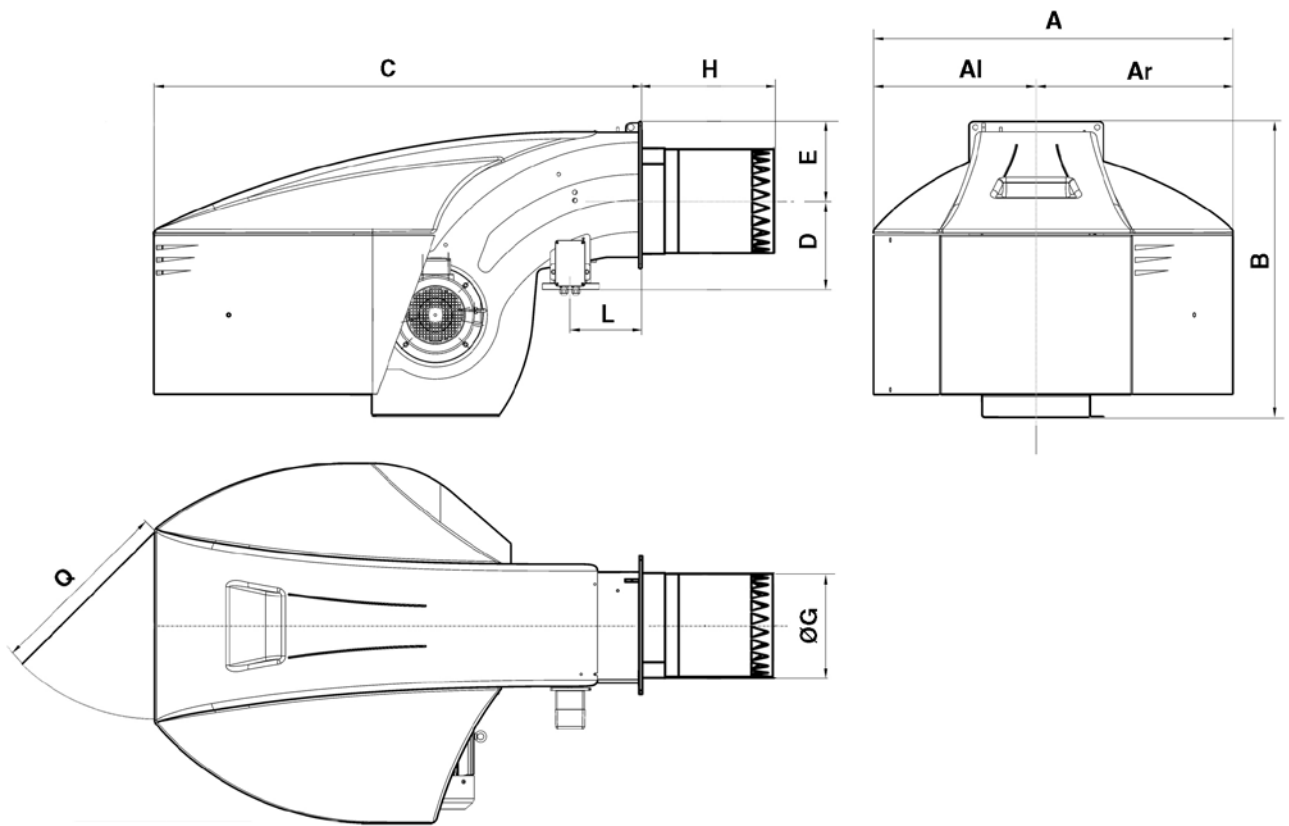

	A	Al	Ar	B	C	D	E	ØG	H			L	Q
									KN	KM	KL		
N6 G-E/-V/-R	990	479	510	837	1361	245	225	320	330	450	570	215	600
N6 G-EF3/-VF3									400	520	640		
N7 G-E/-V/-R	1128	511	618	961	1529	276	225	370	375	505	635	225	600
N7 G-EF3/-VF3									420	550	680		
N8 G-E	1414	669	745	1231	1930	344	293	369	500	640	780	230	800
N8 G-EU3									550	700	850		
N9 G-E	1414	669	745	1291	1928	369	293	431,5	550	700	850	230	800
N9 G-EU3									550	700	850		

Connecting flange

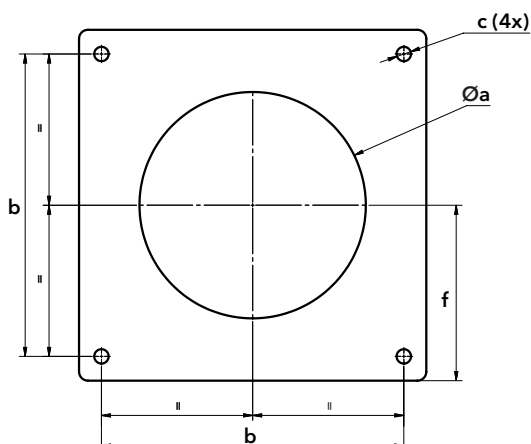

	Øa	b	c	f
N6 G-...	330-340	340	M16	200
N6 G-...F3	300-340			
N7 G-...	380-400	400	M16	235
N7 G-...F3	360-400			
N8 G-...	390-410	505	M20	293
N8 G-EU3				
N9 G-...	460-480	505	M20	293
N9 G-EU3				

GAS TRAINS AND FILTERS | GAS RANGE

Siemens

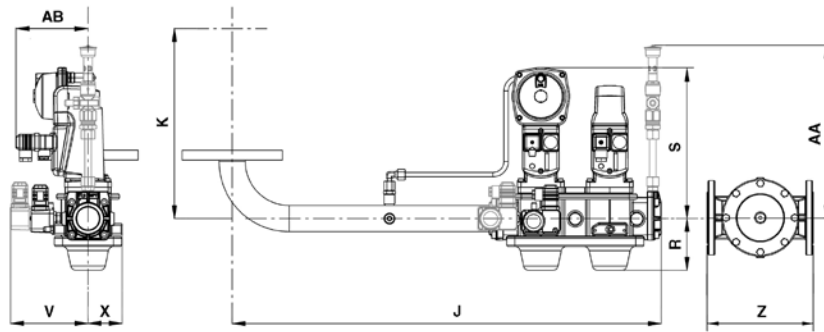

	±5 mm	J	K				R	S	V	V ₁ *	X	AA*	AB
			N6	N7	N8	N9							
s1"1/2		795	375	405	598	623	100	285	105	145	65	320	135
s2"		805	405	365	598	623	105	285	105	145	100	325	140
s65		795	355	385	598	623	120	305	125	125	110	365	135
s80		815	375	405	598	623	135	315	125	125	110	375	135
s100		855	375	405	598	623	145	335	145	145	125	385	135
s125		905	375	405	598	623	180	350	160	160	140	400	135

Dungs

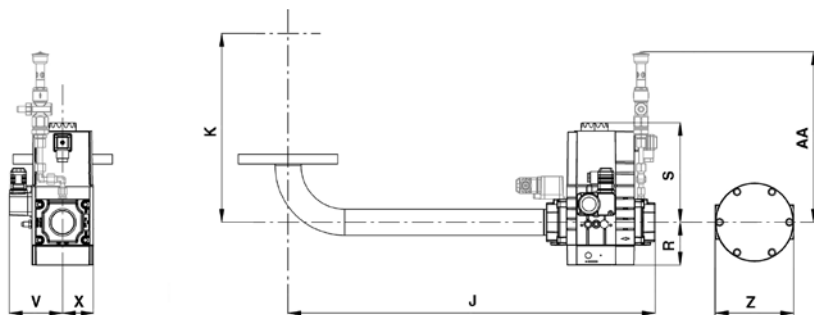

	±5 mm	J	K				R	S	V	X	AA*
			N6	N7	N8	N9					
d1"1/4		625	375	405	598	623	65	175	100	60	320
d1"1/2		685	375	405	598	623	80	190	100	60	320
d2"		760	405	435	598	623	100	330	125	115	385
d65		795	355	385	598	623	185	250	110	100	385
d80		815	375	405	598	623	210	295	155	110	275
d100		875	375	405	598	623	250	330	165	115	275

*: equipment for continuous operation (PED option)

Filters

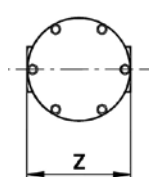

	Z
Rp1"1/2	157
Rp2"	155

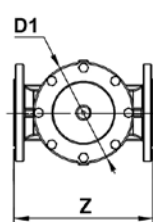

	ØD1	Z
DN40	155	223
DN50	155	210
DN65	190	245
DN80	208	285
DN100	263	340
DN125	315	400
DN150	356	450

TECHNICAL DATA | DUAL FUEL RANGE

NEXTRON 6 - 7 GL-RZ3

Low NOx Class 2

	N6.2400 GL-RZ3	N6.2900 GL-RZ3	N7.3600 GL-RZ3	N7.4500 GL-RZ3
Burner output in gas [kW]	290 - 2550	290 - 2950	300 - 3600	410 - 4350
Burner output in fuel [kW]	730 - 2470	730 - 2750	1090 - 3600	1230 - 4350
Gas pressure [mbar]	50 ... 300	50 ... 300	50 ... 300	50 ... 300
Fan motor	400 V - 50 Hz - 3 kW	400 V - 50 Hz - 4 kW	400 V - 50 Hz - 5,5 kW	400 V - 50 Hz - 7,5 kW
Oil pump motor	400 V - 50 Hz - 0,55 kW	400 V - 50 Hz - 0,55 kW	400 V - 50 Hz - 0,74 kW	400 V - 50 Hz - 0,74 kW
Auxiliary voltage	1NPE AC 230 V - 50 Hz	1NPE AC 230 V - 50 Hz	1NPE AC 230 V - 50 Hz	1NPE AC 230 V - 50 Hz
Power supply	3NPE AC 400 V - 50 Hz	3NPE AC 400 V - 50 Hz	3NPE AC 400 V - 50 Hz	3NPE AC 400 V - 50 Hz
Acoustic level [dB(A)]	< 70	< 71	< 74	< 75,5

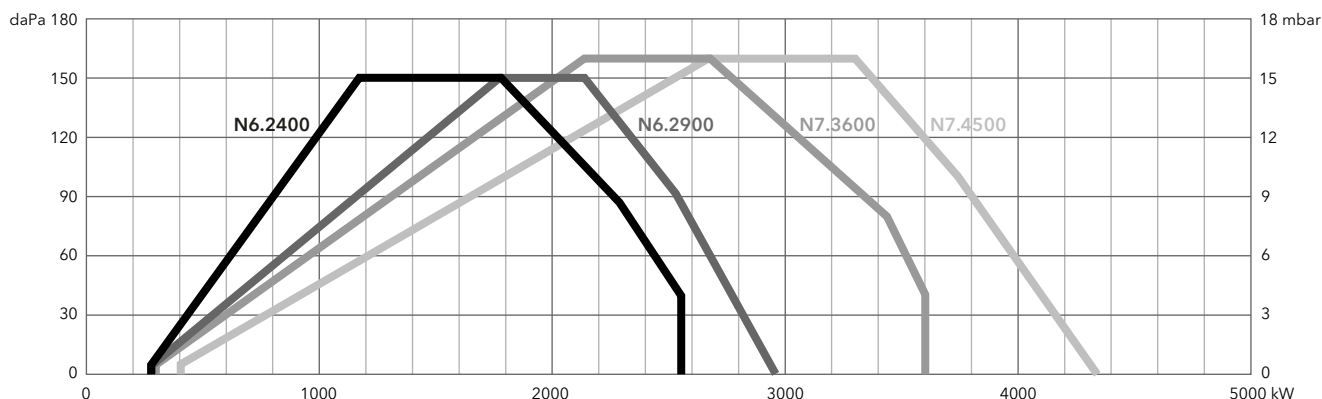

NEXTRON 6 - 7 - 8 - 9 GL-E

Low NOx Class 2

	N6.2400 GL-E	N6.2900 GL-E	N7.3600 GL-E	N7.4500 GL-E
Burner output in gas [kW]	250 - 2230	320 - 2970	490 - 3650	510 - 4750
Burner output in fuel [kW]	510 - 2030	650 - 2970	900 - 3650	1 300 - 4750
Gas pressure [mbar]	50 ... 300	50 ... 300	50 ... 300	50 ... 300
Fan motor	400 V - 50 Hz - 3 kW	400 V - 50 Hz - 4 kW	400 V - 50 Hz - 5,5 kW	400 V - 50 Hz - 7,5 kW
Oil pump motor	400 V - 50 Hz - 0,74 kW	400 V - 50 Hz - 0,74 kW	400 V - 50 Hz - 1,1 kW	400 V - 50 Hz - 1,5 kW
Auxiliary voltage	1NPE AC 230 V - 50 Hz	1NPE AC 230 V - 50 Hz	1NPE AC 230 V - 50 Hz	1NPE AC 230 V - 50 Hz
Power supply	3NPE AC 400 V - 50 Hz	3NPE AC 400 V - 50 Hz	3NPE AC 400 V - 50 Hz	3NPE AC 400 V - 50 Hz
Acoustic level [dB(A)]	< 70	< 71	< 74	< 75

	N8.5800 GL-E	N8.7100 GL-E	N9.8700 GL-E	N9.10400 GL-E
Burner output in gas [kW]	800 - 5350	820 - 7340	880 - 8530	910 - 10620
Burner output in fuel [kW]	1210 - 5350	1 470 - 7340	2 400 - 8530	2820 - 10620
Gas pressure [mbar]	100 ... 500	100 ... 500	100 ... 500	100 ... 500
Fan motor	400 V - 50 Hz - 11 kW	400 V - 50 Hz - 15 kW	400 V - 50 Hz - 18,5 kW	400 V - 50 Hz - 22 kW
Oil pump motor	400 V - 50 Hz - 3 kW	400 V - 50 Hz - 3 kW	400 V - 50 Hz - 3 kW	400 V - 50 Hz - 4 kW
Auxiliary voltage	1NPE AC 230 V - 50 Hz	1NPE AC 230 V - 50 Hz	1NPE AC 230 V - 50 Hz	1NPE AC 230 V - 50 Hz
Power supply	3NPE AC 400 V - 50 Hz	3NPE AC 400 V - 50 Hz	3NPE AC 400 V - 50 Hz	3NPE AC 400 V - 50 Hz
Acoustic level [dB(A)]	< 77,5	< 79,5	< 81	< 82

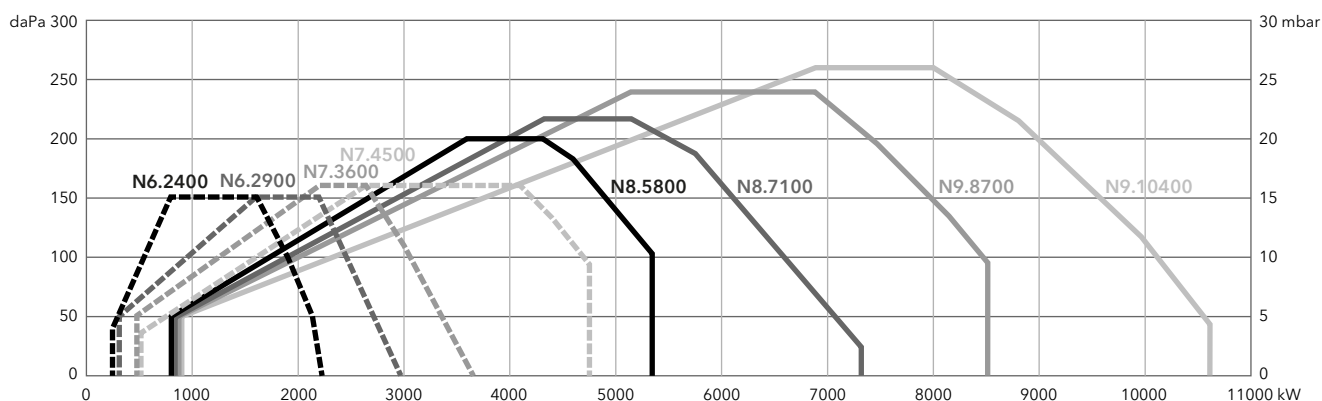

TECHNICAL DATA | DUAL FUEL RANGE

NEXTRON 6 - 7 GL-EF3

Low NOx Class 3

	N6.2400 GL-EF3	N6.2900 GL-EF3	N7.3600 GL-EF3	N7.4500 GL-EF3
Burner output in gas [kW]	280 - 1920	340 - 2890	470 - 3980	510 - 4500
Burner output in fuel [kW]	360 - 1920	480 - 2890	680 - 3980	740 - 4500
Gas pressure [mbar]	50 ... 300	50 ... 300	50 ... 300	50 ... 300
Fan motor	400 V - 50 Hz - 3 kW	400 V - 50 Hz - 4 kW	400 V - 50 Hz - 7,5 kW	400 V - 50 Hz - 7,5 kW
Oil pump motor	400 V - 50 Hz - 0,74 kW	400 V - 50 Hz - 0,74 kW	400 V - 50 Hz - 1,1 kW	400 V - 50 Hz - 1,5 kW
Auxiliary voltage	1NPE AC 230 V - 50 Hz	1NPE AC 230 V - 50 Hz	1NPE AC 230 V - 50 Hz	1NPE AC 230 V - 50 Hz
Power supply	3NPE AC 400 V - 50 Hz	3NPE AC 400 V - 50 Hz	3NPE AC 400 V - 50 Hz	3NPE AC 400 V - 50 Hz
Acoustic level [dB(A)]	< 69	< 71	< 76	< 74

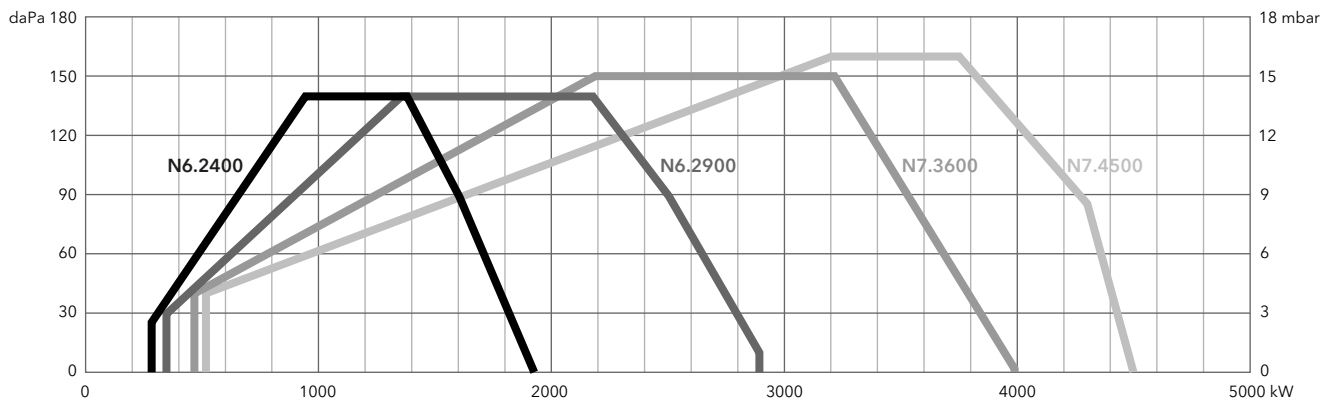

NEXTRON 8 - 9 GL-EF3/GL-EUF

Low NOx Class 3

	N8.5700 GL-EF3	N9.6500 GL-EF3	N9.8700 GL-EUF	N9.10400 GL-EUF
Burner output in gas [kW]	830 - 6450	830 - 6950	1040 - 8500	1160 - 9570
Burner output in fuel [kW]	1030 - 6450	1030 - 6600	1800 - 8500	2550 - 9570
Gas pressure [mbar]	100 ... 500	100 ... 500	100 ... 500	100 ... 500
Fan motor	400 V - 50 Hz - 15 kW	400 V - 50 Hz - 22 kW	400 V - 50 Hz - 18,5 kW	400 V - 50 Hz - 22 kW
Oil pump motor	400 V - 50 Hz - 3 kW	400 V - 50 Hz - 3 kW	400 V - 50 Hz - 3 kW	400 V - 50 Hz - 4 kW
Auxiliary voltage	1NPE AC 230 V - 50 Hz	1NPE AC 230 V - 50 Hz	1NPE AC 230 V - 50 Hz	1NPE AC 230 V - 50 Hz
Power supply	3NPE AC 400 V - 50 Hz	3NPE AC 400 V - 50 Hz	3NPE AC 400 V - 50 Hz	3NPE AC 400 V - 50 Hz
Acoustic level [dB(A)]	< 80	< 83	< 81	< 82

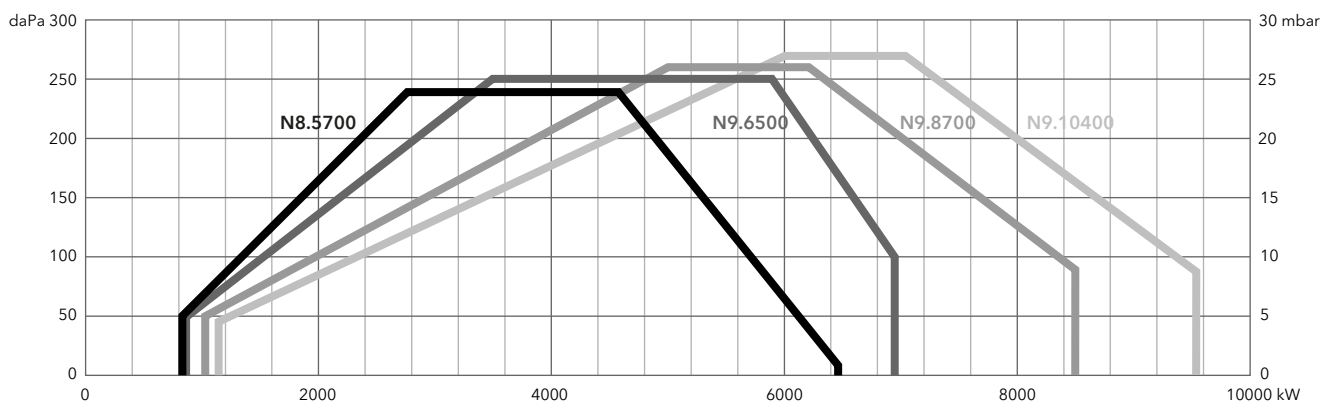

OVERALL DIMENSIONS | DUAL FUEL RANGE

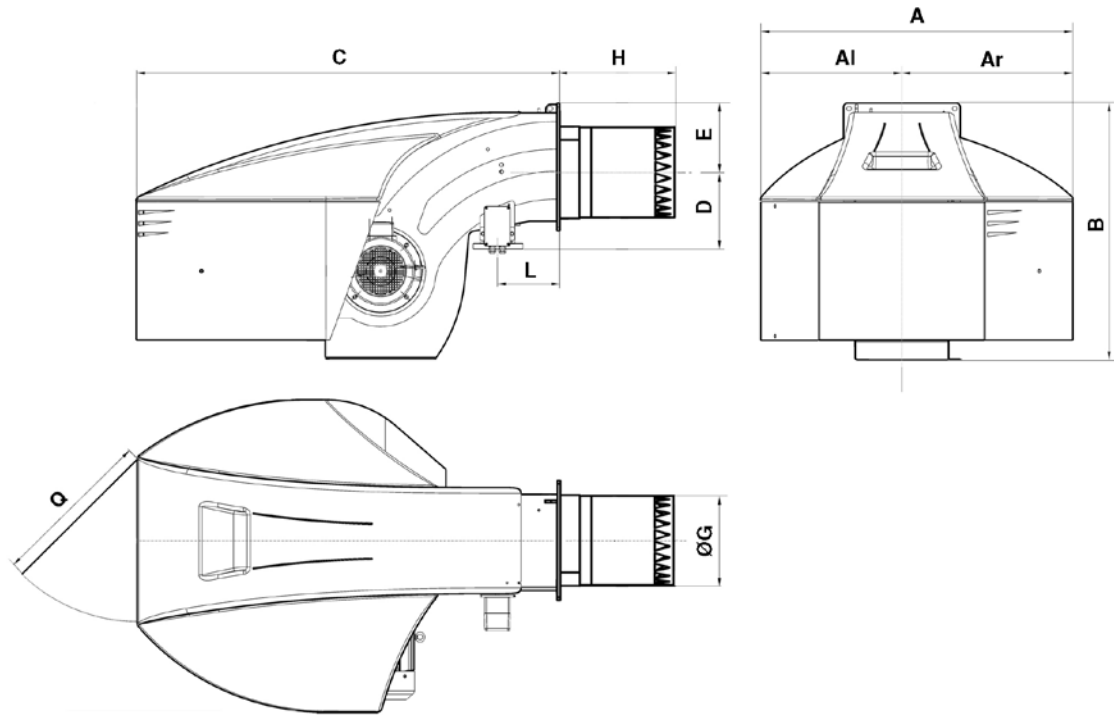

	A	Al	Ar	B	C	D	E	ØG	H			L	Q
									KN	KM	KL		
N6... GL-RZ3	990	479	510	837	1361	245	225	320	330	450	570	215	600
N6.2400 GL-E	990	479	510	837	1361	245	225	290	330	450	570	215	600
N6.2900 GL-E								310					
N6... GL-EF3	990	479	510	837	1361	245	225	264	400	520	640	215	600
N7.3600 GL-RZ3	1128	511	618	961	1529	276	255	320	375	505	635	225	600
N7.4500 GL-RZ3								340					
N7.3600 GL-E	1128	511	618	961	1529	276	255	340	375	505	635	225	600
N7.4500 GL-E								370					
N7... GL-EF3	1128	511	618	961	1529	276	255	325	420	550	680	225	600
N8.5800 GL-E	1414	669	745	1231	1930	391	293	400	562	702	842	230	800
N8.7100 GL-E								415					
N9... GL-E	1414	669	745	1291	1928	434	293	431,5	355	505	655	230	800
N8.5700 GL-EF3	1414	669	745	1231	1930	391	293	369	528	668	808	230	800
N9.6500 GL-EF3				1291	1928	434		431,5					
N9... GL-EUF	1414	669	745	1291	1928	434	293	431,5	575	725	875	230	800

Connecting flange

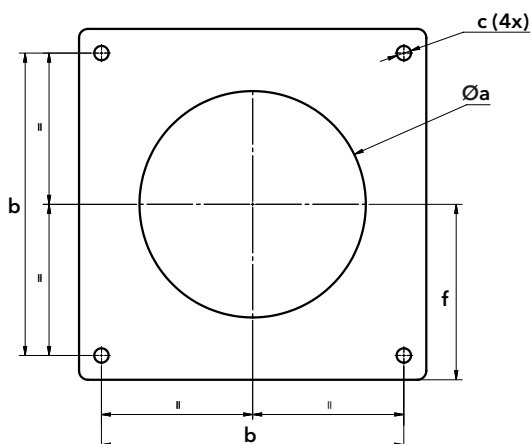

	Øa	b	c	f
N6... GL-RZ3	330-340	340	M16	200
N6.2400 GL-E	300-340	340	M16	200
N6.2900 GL-E	320-340			
N6... GL-EF3	300-340	340	M16	200
N7.3600 GL-RZ3	330-400	400	M16	235
N7.4500 GL-RZ3	350-400			
N7.3600 GL-E	350-400	400	M16	235
N7.4500 GL-E	380-400			
N7... GL-EF3	360-400	400	M16	235
N8.5800 GL-E	430-480	505	M20	293
N8.7100 GL-E	445-480			
N9... GL-E	445-480	505	M20	293
N8.5700 GL-EF3	380-410	505	M20	293
N9.6500 GL-EF3	445-480			
N9... GL-EUF	445-480	505	M20	293

GAS TRAINS AND FILTERS | DUAL FUEL RANGE

Siemens

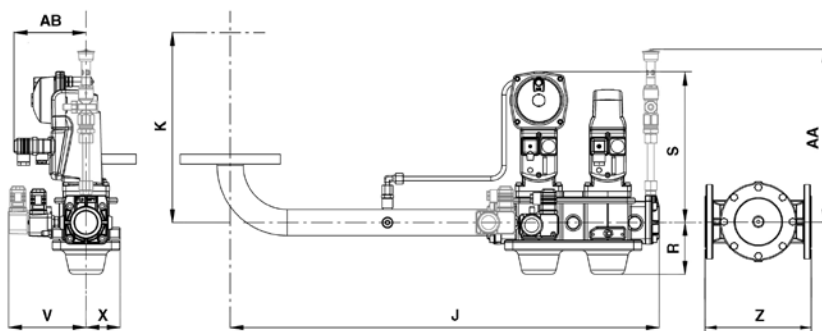

	±5 mm	J	K				R	S	V	V ₁ *	X	AA*	AB
			N6	N7	N8	N9							
s1"1/2		795	375	405	598	623	100	285	105	145	65	320	135
s2"		805	405	365	598	623	105	285	105	145	100	325	140
s65		795	355	385	598	623	120	305	125	125	110	365	135
s80		815	375	405	598	623	135	315	125	125	110	375	135
s100		855	375	405	598	623	145	335	145	145	125	385	135
s125		905	375	405	598	623	180	350	160	160	140	400	135

Dungs

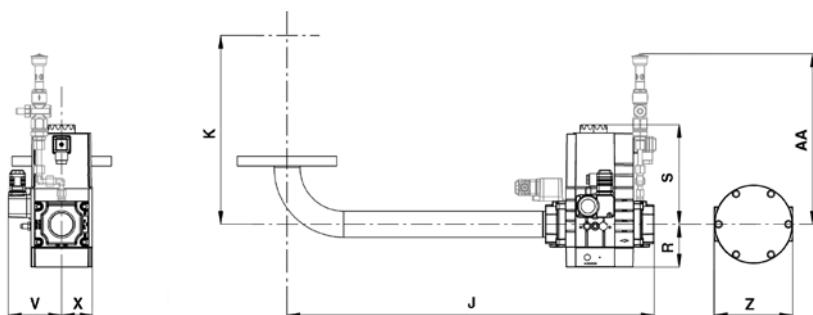

	±5 mm	J	K				R	S	V	X	AA*
			N6	N7	N8	N9					
d1"1/4		625	375	405	598	623	65	175	100	60	320
d1"1/2		685	375	405	598	623	80	190	100	60	320
d2"		760	405	435	598	623	100	330	125	115	385
d65		795	355	385	598	623	185	250	110	100	385
d80		815	375	405	598	623	210	295	155	110	275
d100		875	375	405	598	623	250	330	165	115	275

*: equipment for continuous operation (PED option)

Filters

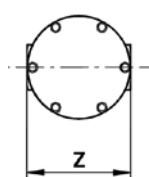

	Z
Rp1"1/2	157
Rp2"	155

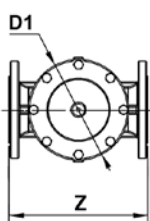

	ØD1	Z
DN40	155	223
DN50	155	210
DN65	190	245
DN80	208	285
DN100	263	340
DN125	315	400
DN150	356	450

TECHNICAL DATA | LIGHT OIL RANGE

NEXTRON 6 - 7 L-E

Low NOx Class 2 (< 185 mg/kWh)

	N6.2400 L-E	N6.2900 L-E	N7.3600 L-E	N7.4500 L-E
Burner output [kW]	510 - 2030	650 - 3100	900 - 3850	1300 - 4900
Fuel	Light oil EL 11,86 kWh/kg, maximum viscosity 6,0 mm ² /s at 20°C			
Fan motor	400 V - 50 Hz - 3 kW	400 V - 50 Hz - 4 kW	400 V - 50 Hz - 5,5 kW	400 V - 50 Hz - 7,5 kW
Oil pump motor	400 V - 50 Hz - 0,74 kW	400 V - 50 Hz - 0,74 kW	400 V - 50 Hz - 1,1 kW	400 V - 50 Hz - 1,5 kW
Auxiliary voltage	1NPE AC 230 V - 50 Hz	1NPE AC 230 V - 50 Hz	1NPE AC 230 V - 50 Hz	1NPE AC 230 V - 50 Hz
Power supply	3NPE AC 400 V - 50 Hz	3NPE AC 400 V - 50 Hz	3NPE AC 400 V - 50 Hz	3NPE AC 400 V - 50 Hz
Acoustic level [dB(A)]	< 70	< 71	< 74	< 75

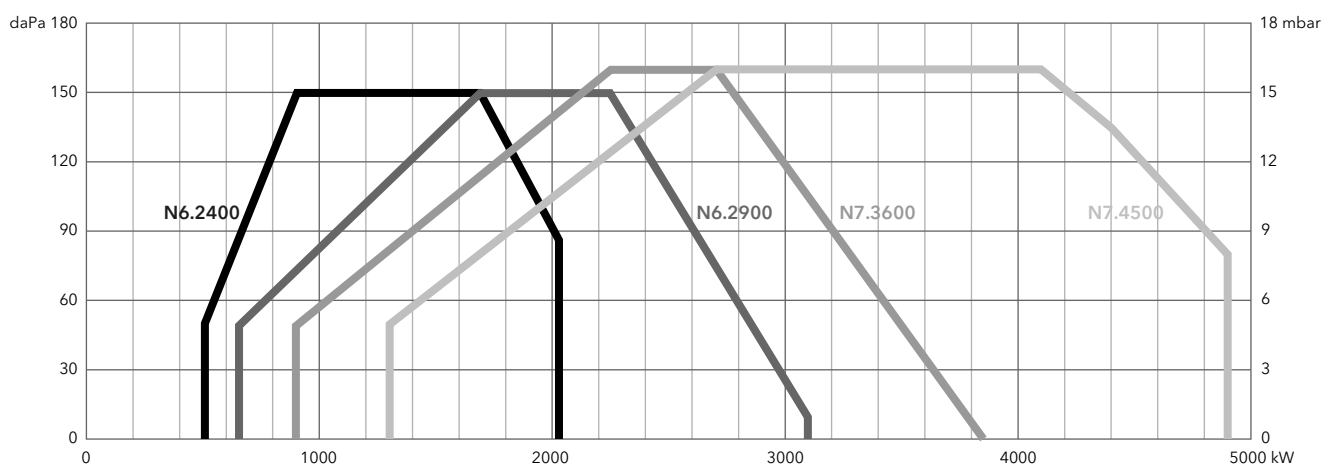

NEXTRON 8 - 9 L-E

Low NOx Class 2 (< 185 mg/kWh)

	N8.5800 L-E	N8.7100 L-E	N9.8700 L-E	N9.10400 L-E
Burner output [kW]	1350 - 5350	1470 - 7340	2400 - 8530	2820 - 10620
Fuel	Light oil EL 11,86 kWh/kg, maximum viscosity 6,0 mm ² /s at 20°C			
Fan motor	400 V - 50 Hz - 11 kW	400 V - 50 Hz - 15 kW	400 V - 50 Hz - 18,5 kW	400 V - 50 Hz - 22 kW
Oil pump motor	400 V - 50 Hz - 3 kW	400 V - 50 Hz - 3 kW	400 V - 50 Hz - 4 kW	400 V - 50 Hz - 4 kW
Auxiliary voltage	1NPE AC 230 V - 50 Hz	1NPE AC 230 V - 50 Hz	1NPE AC 230 V - 50 Hz	1NPE AC 230 V - 50 Hz
Power supply	3NPE AC 400 V - 50 Hz	3NPE AC 400 V - 50 Hz	3NPE AC 400 V - 50 Hz	3NPE AC 400 V - 50 Hz
Acoustic level [dB(A)]	< 77,5	< 79,5	< 81	< 82

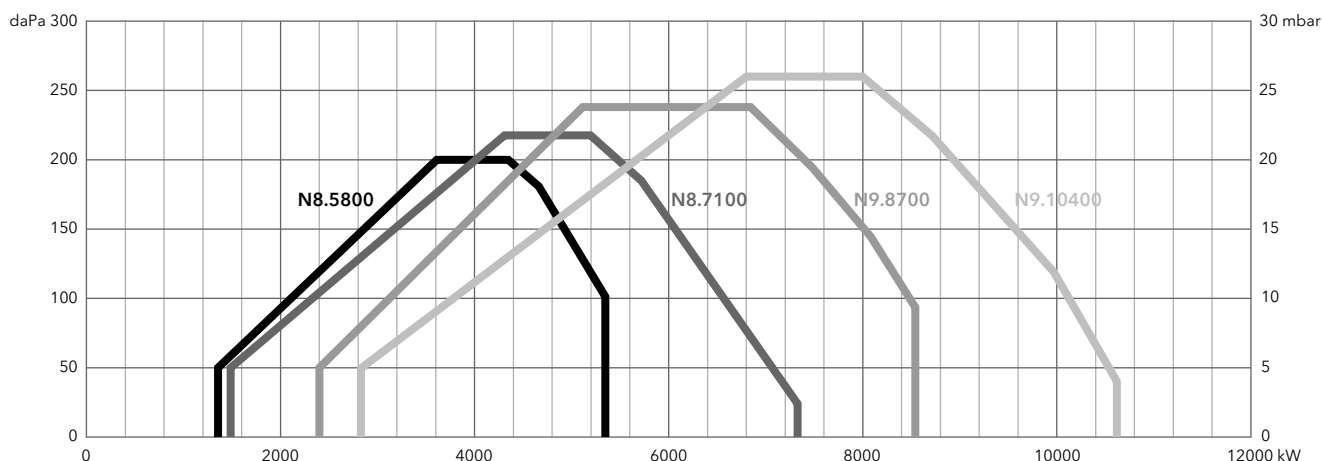

TECHNICAL DATA | LIGHT OIL RANGE

NEXTRON 6 - 7 L-EF3

Low NOx Class 3 (< 120 mg/kWh)

	N6.2400 L-EF3	N6.2900 L-EF3	N7.3600 L-EF3	N7.4500 L-EF3
Burner output [kW]	360 - 1850	480 - 2950	680 - 4070	740 - 4820
Fuel	Light oil EL 11,86 kWh/kg, maximum viscosity 6,0 mm ² /s at 20°C			
Fan motor	400 V - 50 Hz - 3 kW	400 V - 50 Hz - 4 kW	400 V - 50 Hz - 7,5 kW	400 V - 50 Hz - 7,5 kW
Oil pump motor	400 V - 50 Hz - 0,74 kW	400 V - 50 Hz - 0,74 kW	400 V - 50 Hz - 1,1 kW	400 V - 50 Hz - 1,5 kW
Auxiliary voltage	1NPE AC 230 V - 50 Hz	1NPE AC 230 V - 50 Hz	1NPE AC 230 V - 50 Hz	1NPE AC 230 V - 50 Hz
Power supply	3NPE AC 400 V - 50 Hz	3NPE AC 400 V - 50 Hz	3NPE AC 400 V - 50 Hz	3NPE AC 400 V - 50 Hz
Acoustic level [dB(A)]	< 69	< 71	< 76	< 74

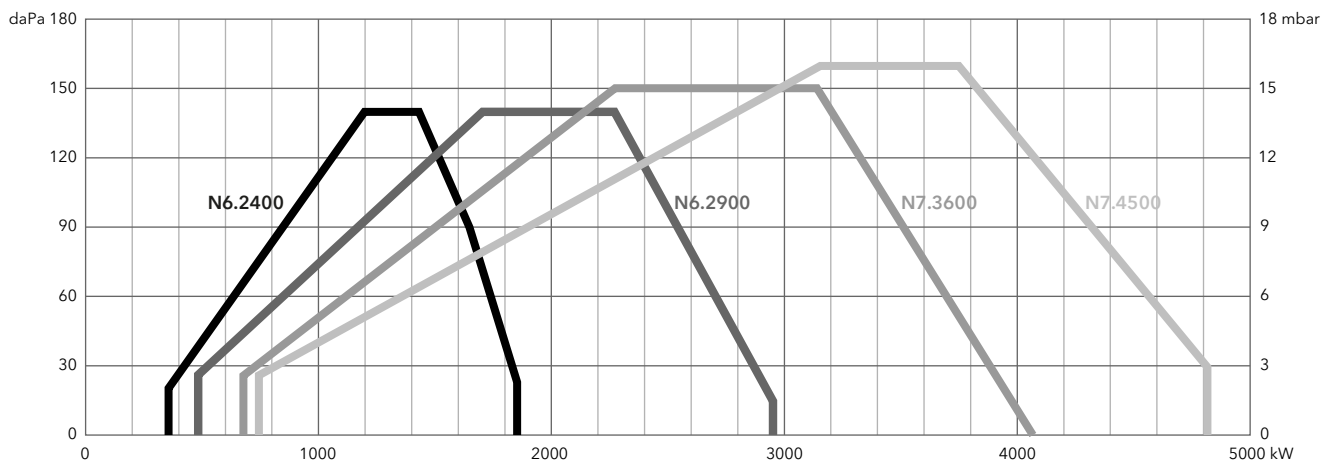

NEXTRON 8 - 9 L-EF3/L-EUF

Low NOx Class 3 (< 120 mg/kWh)

	N8.5700 L-EF3	N9.6500 L-EF3	N9.8700 L-EUF	N9.10400 L-EUF
Burner output [kW]	1100 - 6450	1200 - 6600	1800 - 8500	2550 - 9570
Fuel	Light oil EL 11,86 kWh/kg, maximum viscosity 6,0 mm ² /s at 20°C			
Fan motor	400 V - 50 Hz - 15 kW	400 V - 50 Hz - 22 kW	400 V - 50 Hz - 18,5 kW	400 V - 50 Hz - 22 kW
Oil pump motor	400 V - 50 Hz - 3 kW	400 V - 50 Hz - 3 kW	400 V - 50 Hz - 3 kW	400 V - 50 Hz - 4 kW
Auxiliary voltage	1NPE AC 230 V - 50 Hz	1NPE AC 230 V - 50 Hz	1NPE AC 230 V - 50 Hz	1NPE AC 230 V - 50 Hz
Power supply	3NPE AC 400 V - 50 Hz	3NPE AC 400 V - 50 Hz	3NPE AC 400 V - 50 Hz	3NPE AC 400 V - 50 Hz
Acoustic level [dB(A)]	< 80	< 83	< 81	< 82

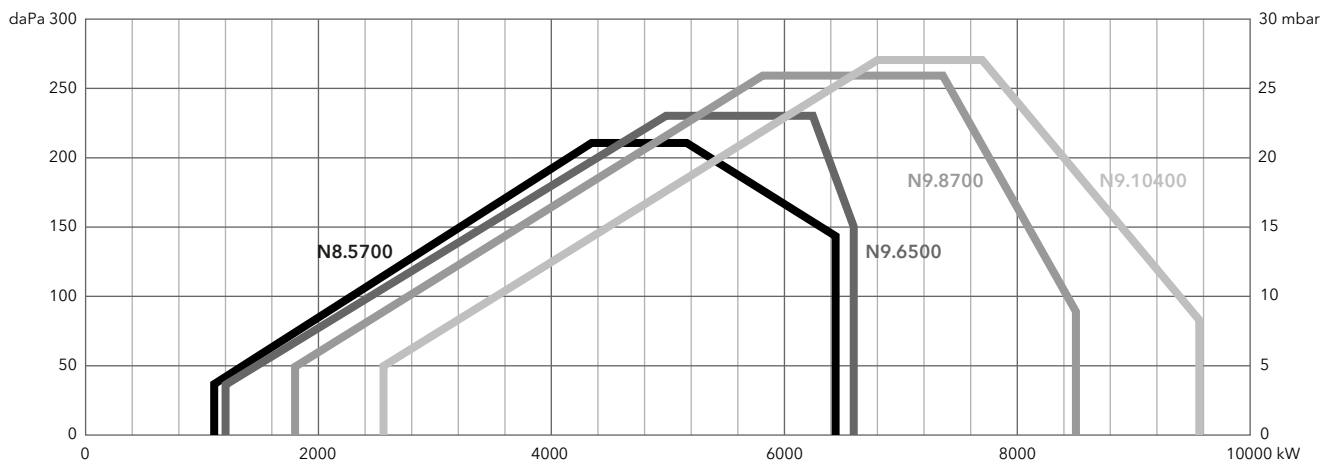

OVERALL DIMENSIONS | LIGHT OIL RANGE

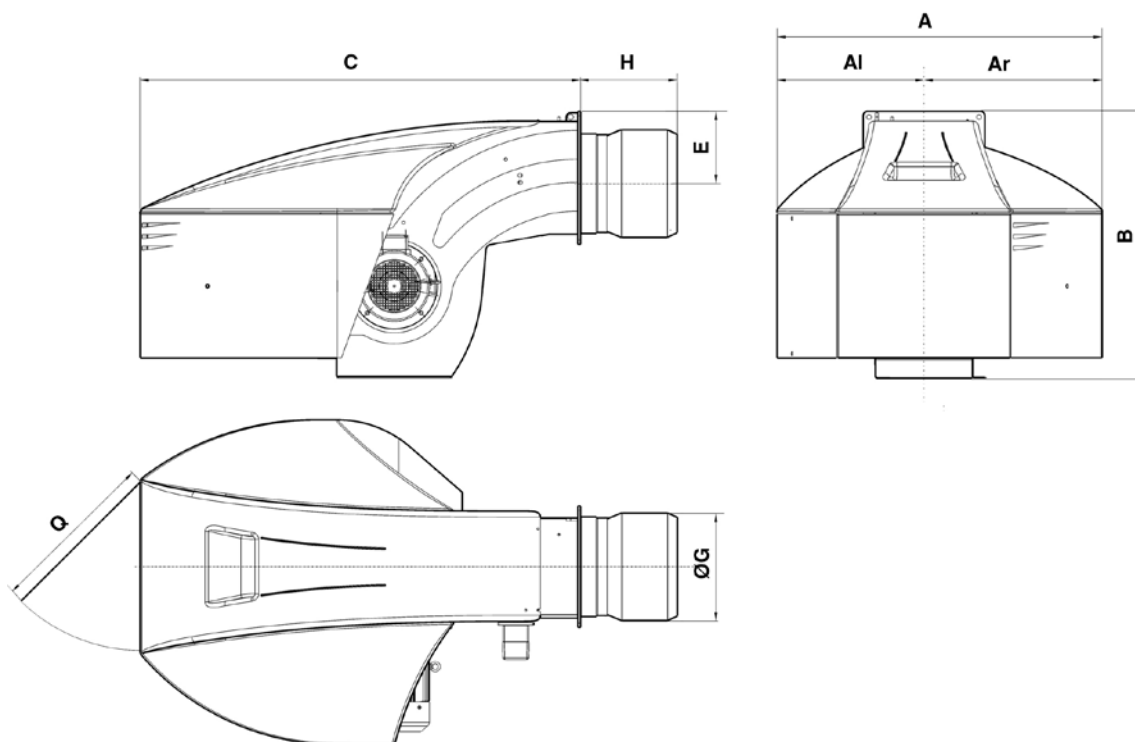

	A	AI	Ar	B	C	E	ØG	H			Q
								KN	KM	KL	
N6.2400 L-E	990	479	510	837	1361	225	290	330	450	570	600
N6.2900 L-E							310				
N7.3600 L-E	1128	511	618	961	1529	255	330	375	505	635	
N7.4500 L-E							370				
N6.2400 L-EF3	990	479	510	837	1361	225	264	330	450	570	600
N6.2900 L-EF3							264				
N7.3600 L-EF3	1128	511	618	961	1529	255	325	375	505	635	
N7.4500 L-EF3							325				

Connecting flange

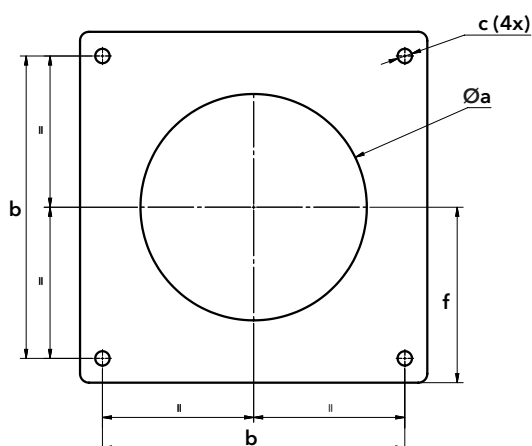

	Øa	b	c	f
N6.2400 L-E	300-340	340	M16	200
N6.2900 L-E	320-340			
N7.3600 L-E	340-400	400	M16	235
N7.4500 L-E	380-400			
N6.2400 L-EF3	300-340	340	M16	200
N6.2900 L-EF3				
N7.3600 L-EF3	360-400	400	M16	235
N7.4500 L-EF3				

OVERALL DIMENSIONS | LIGHT OIL RANGE

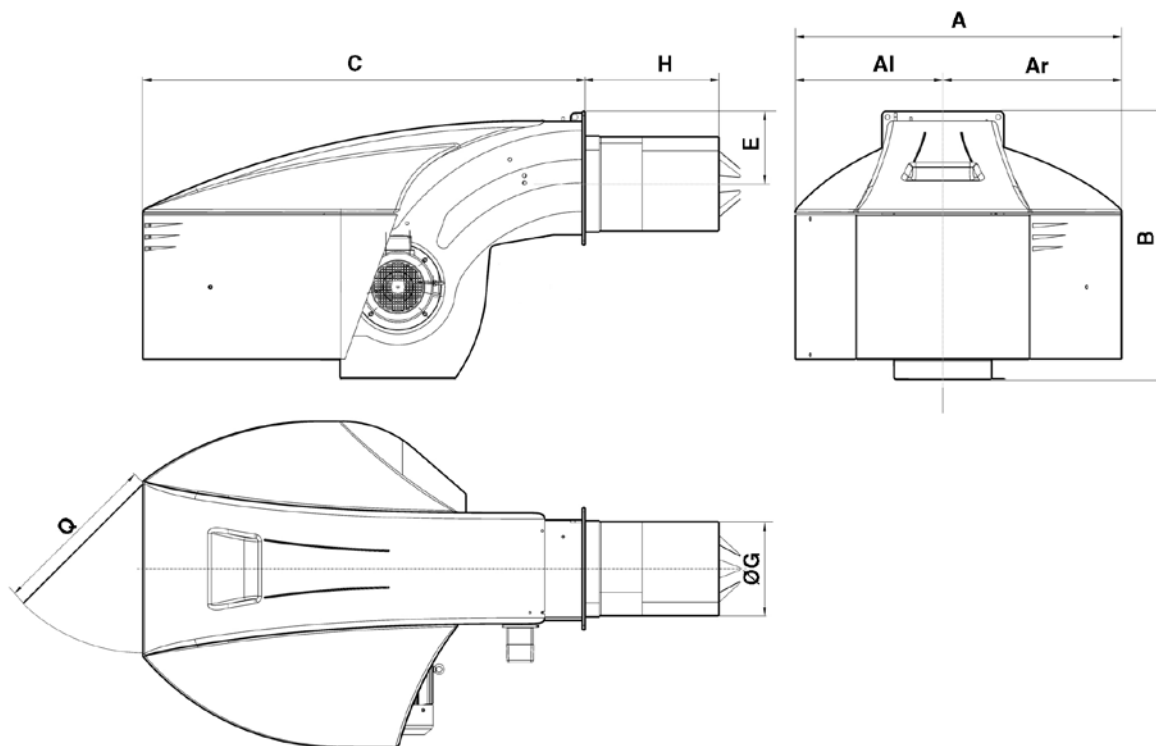

	A	Al	Ar	B	C	E	ØG	H			Q
								KN	KM	KL	
N8.5800 L-E	1414	669	745	1231	1930	293	400	562	702	842	800
N8.7100 L-E							415	583	723	863	
N9.8700 L-E	1414	669	745	1291	1928	293	431,5	355	505	655	800
N9.10400 L-E							369	528	668	808	
N8.5700 L-EF3	1414	669	745	1291	1928	293	431,5	543	693	843	800
N9.6500 L-EF3							369	528	668	808	
N9.8700 L-EUF	1414	669	745	1291	1928	293	431,5	575	725	875	800
N9.10400 L-EUF							431,5	575	725	875	

Connecting flange

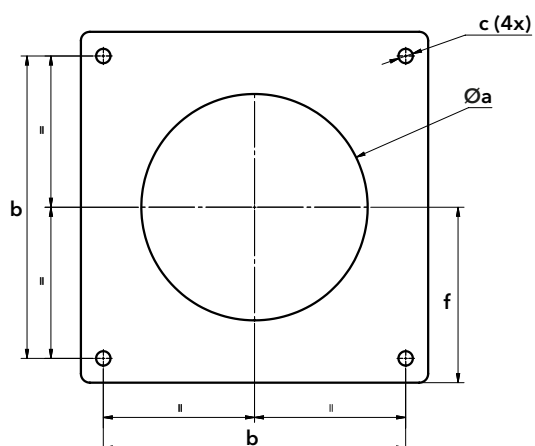

	Øa	b	c	f
N8.5800 L-E	430-480	505	M20	293
N8.7100 L-E	454-480			
N9.8700 L-E	445-480	505	M20	293
N9.10400 L-E	445-480	505	M20	293
N8.5700 L-EF3	380-410	505	M20	293
N9.6500 L-EF3	445-480			
N9.8700 L-EUF	445-480	505	M20	293
N9.10400 L-EUF	445-480	505	M20	293

SUBSIDIARIES:

GERMANY

Dreichstrasse, 10
64546 Mörfelden
Walldorf
Tel. +49 06 105 968 192
Fax +49 06 105 968 199

NETHERLANDS

Meerpaalweg, 1
1332 BB Almere
P.O. box 30048
1303 AA Almere
Tel. +31 088 69 573 11
Fax +31 088 69 573 90

ENGLAND

Suite 3, The Crown House
Blackpole East,
Blackpole Road,
Worcester WR3 8SG
Tel. +44 01905 788010
Fax +44 01905 788011

FRANCE

14, rue du Saule Trapu
Parc d'activité du Moulin
91882 Massy
Tel. +33 01 60 13 64 64
Fax +33 01 60 13 64 65

ITALY

Viale Roma, 41
28100 Novara
Tel. +39 0732 633 590
Fax +39 0732 633 599

RUSSIA

Eniseyskaya str. 1, bld 1,
Office Center "LIRA" #415
129344 Moscow
Tel. +7 495 213 0300 #5700
Fax +7 495 213 0302

CHINA

17A2, V-Capital Bldg
No. 333 Xian Xia Road
200336 Shanghai
Tel. +86 21 6039 8691
Fax +86 21 6039 8620

Contact us to know more
about our products and solutions

contact@elco-burners.com