

FERROLI

INSTALLATION AND MAINTENANCE INSTRUCTIONS

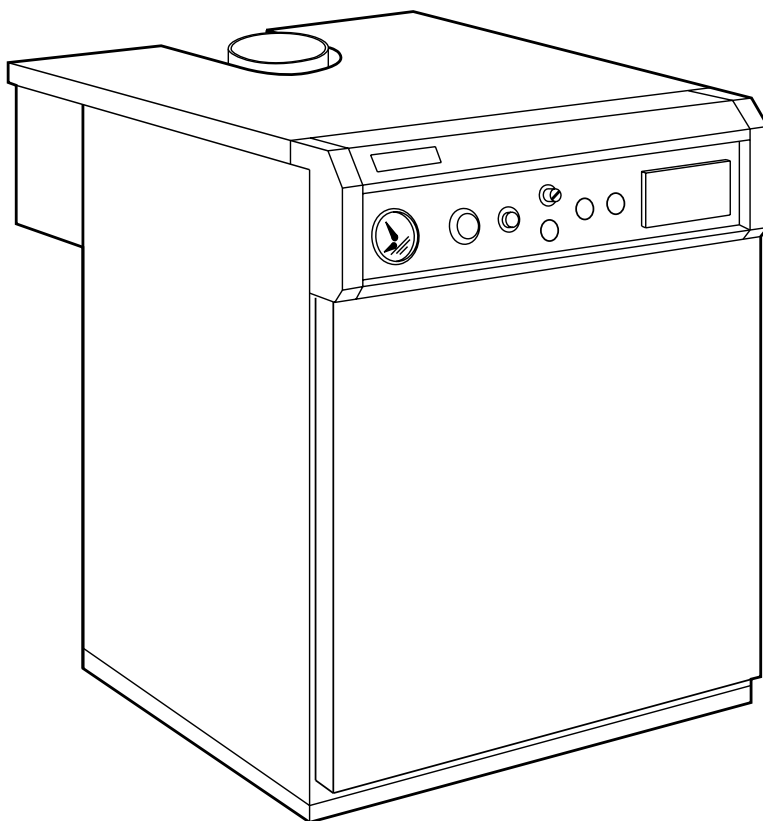

PEGASUS F2 T

**HIGH EFFICIENCY GAS-FIRED
CAST-IRON BOILERS**

Models 51 - 68 - 85 - 102



Contents

1. General technical data
2. Dimensional and technical characteristics
3. Installation
4. Wiring diagrams
5. Startup and shutdown
6. Gas regulation and conversion
7. Maintenance and cleaning
8. Fault finding

1. GENERAL TECHNICAL DATA

1.01 Introduction

The **Pegasus F2 T**, with CE approval, is a designed foruse with NATURAL GAS (G 20) or LPG (G 31) for indirect central heating and hot water.

1.02 Installation requirements

Only CORGI registered installers should fit the Pegasus boilers.

The boiler installation should comply with relevant British standards specifications, codes of practice, and current building Regulations, together with any special regional requirements of the local authorities, gas supplier and insurance companies.

2. DIMENSIONS AND TECHNICAL DATA

2.01 Dimensional data (see fig. 1 and table 2)

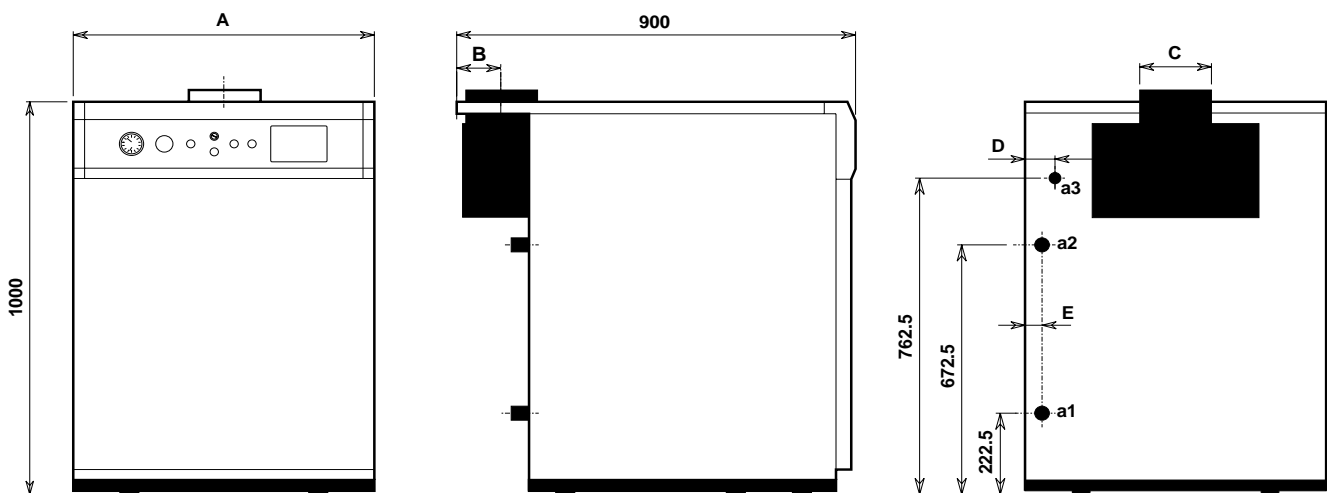

Fig. 1

a1 - Return	1 1/2"
a2 - Flow	1 1/2"
a3 - Gas inlet	3/4"

2.02 Technical data

The standard cast-iron **PEGASUS F2 T** boiler is set to operate on NATURAL GAS (G 20).

Tigned to operate with a flow temperature of 82°C and a maximum Δt of 20°C. The limit thermostat is adjustable up to a maximum of 110°C.

Table 1	MODEL	NUMBER OF SECTIONS	HEAT OUTPUT	HEAT INPUT (NET)	HEAT INPUT (GROSS)
			kw	kw	kw
	Pegasus F2 51 T	4	51	56	62,2
	Pegasus F2 68 T	5	68	74,8	83
	Pegasus F2 85 T	6	85	93,5	103,8
	Pegasus F2 102 T	7	102	112	124,3

Table 2	MODEL	DIMENSIONS					CONNECTIONS			WEIGHT INCLUDING PACKAGE Kg.	WATER CONTENT litres	MAX WORKING PRESS. bar
		A mm	B mm	C fl mm	D mm	E mm	RETURN a1 fl	FLOW a2 fl	GAS a3 fl			
	Pegasus F2 51 T	550	96,5	180	43	35	1 1/2"	1 1/2"	3/4"	260	22	4
	Pegasus F2 68 T	640	96,5	180	46	38	1 1/2"	1 1/2"	3/4"	300	26	4
	Pegasus F2 85 T	720	106,5	200	44	36	1 1/2"	1 1/2"	3/4"	350	30	4
	Pegasus F2 102 T	800	106,5	200	42	34	1 1/2"	1 1/2"	3/4"	400	34	4

Table 3	MODEL	No. of MAIN BURNER BARS	MAIN INJECTOR fl mm		PILOT INJECTOR fl mm		GAS SUPPLY PRESSURE mbar		GAS PRESSURE AT BURNER MANIFOLD mbar		GAS FLOW RATE	
			Nat. GAS G20	LPG G31	Nat. Gas G20	LPG G31	Nat. Gas G20	LPG G31	Nat. Gas G20	LPG G31	Nat. Gas G20 m ³ /h	LPG G31 kg/h
	Pegasus F2 51 T	3	3,5	2,15	0,4	0,24	15 to 23	37	13,3	36	5,9	4,34
	Pegasus F2 68 T	4	3,5	2,15	0,4	0,24	15 to 23	37	13,3	36	7,9	5,79
	Pegasus F2 85 T	5	3,5	2,15	0,4	0,24	15 to 23	37	13,3	36	9,9	7,24
	Pegasus F2 102 T	6	3,5	2,15	0,4	0,24	15 to 23	37	13,3	36	11,8	8,68

2.03 Main components

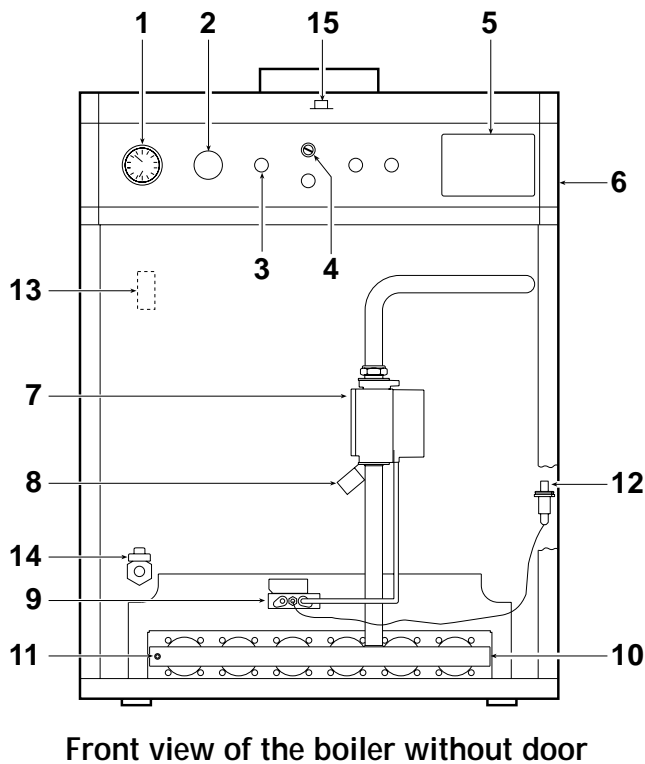

Front view of the boiler without door

Fig. 2a

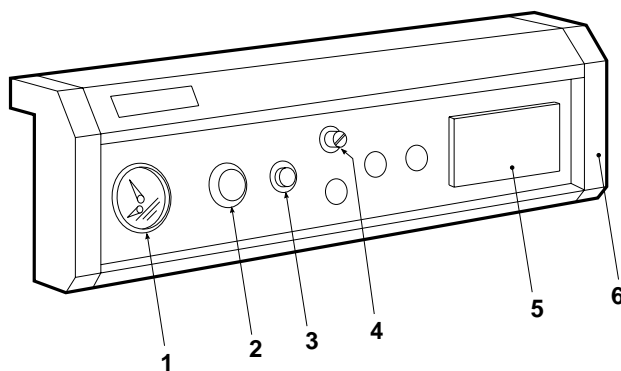

Control panel

Fig. 2b

Key

- | | |
|-------------------------------------|-----------------------------|
| 1. Temperature-pressure gauge | 9. Pilot burner |
| 2. Boiler control thermostat | 10. Burner manifold |
| 3. Boiler on/off switch | 11. Gas pressure test point |
| 4. Flue gas re-set thermostat | 12. Piezo igniter |
| 5. Electronic panel (nto available) | 13. Automatic air vent |
| 6. Control panel | 14. Drain cock |
| 7. Gas valve | 15. Flue gas sampling point |
| 8. Limit thermostat re-set | |

2.04 Characteristic pressure drop curve

Water pressure drop in all models is shown in fig. 3. The following diagram shows the pressure drop in the boiler as a function of the water flow rate.

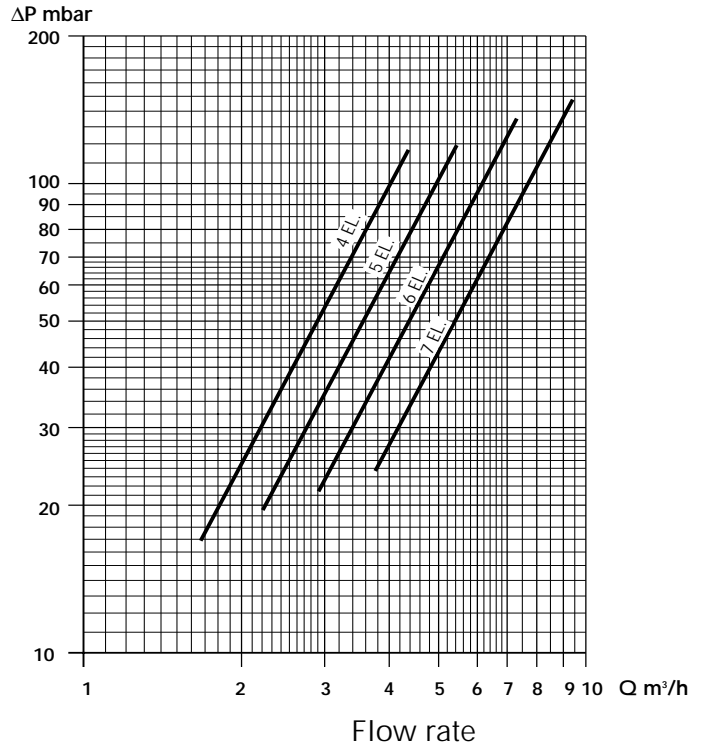

Fig. 3

2.05 Safe discharge of combustion products

- The boiler comes with a FLUE GAS DISCHARGE THERMOSTAT, which provides a high level of safety and control over the discharge of combustion products. This thermostat cuts off the supply of gas to the burner in the event of a faulty flue draft.
- If the FLUE GAS DISCHARGE THERMOSTAT has been activated, you should unscrew the control panel protection cover (part no. 4 in fig. 2a and 2b) and manually “reset” the thermostat. After that, the boiler will return to normal operation.
- If the FLUE GAS DISCHARGE THERMOSTAT needs to be replaced, use original manufacturer’s parts only and make sure the electric connections and positioning of the bulb (see fig. 4) are correct; NEVER UNDER ANY CIRCUMSTANCES LEAVE THE FLUE GAS DISCHARGE THERMOSTAT DISCONNECTED FROM THE ELECTRIC CIRCUIT.
- In case of frequent switching off of the thermostat, contact qualified personnel only.
- During cleaning of the draft diverter, be careful not to damage the thermostat phial.

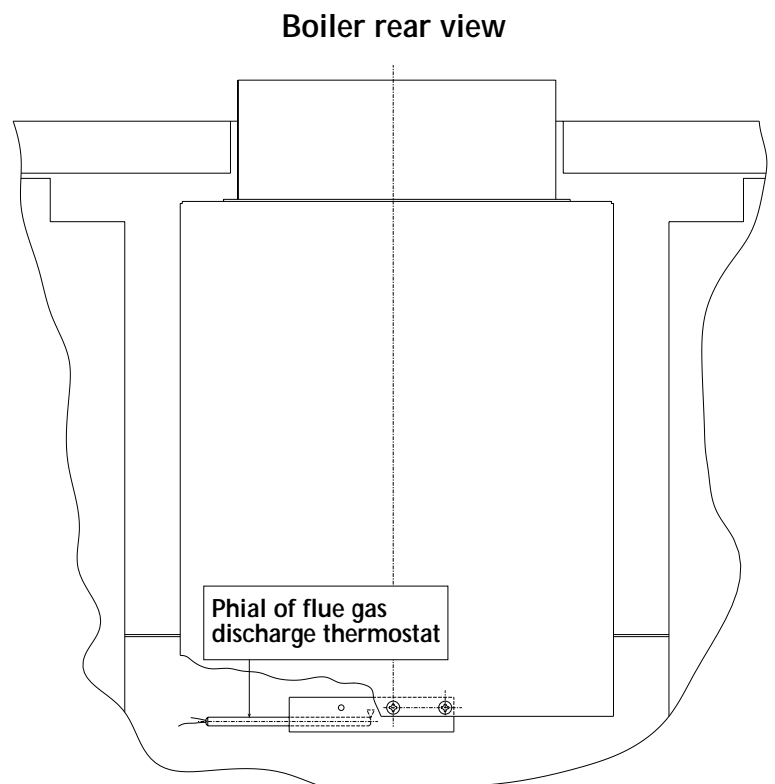

Fig. 4

3. BOILER INSTALLATION

(To be performed by qualified personnel only)

3.01 General warnings

The boiler should be installed according to current regulations. (see para 1.02)

We suggest fitting isolating valves between the boiler and the heating system to isolate the boiler from the system if necessary.

The rise in temperature of the heating water (the difference between the water flow and return temperatures) should not exceed 20°C. This is to prevent possible damage caused by condensation forming in the boiler.

Combustion products should be discharged through a flue with a cross section in accordance with current standards and in any not less than the boiler flue outlet connection.

Connect the gas supply to the boiler in accordance with current regulations. The diameter of the gas connection entering the boiler does not dictate the choice of diameter for the pipe between the boiler and the gas meter which should be selected based upon the pipework length and pressure drop.

Connect the boiler to a single-phase 230 V ~ 50 Hz power supply through a standard terminal block or outlet, with 2A max. fuses connected between the boiler and the power line.

3.02 Boiler water characteristics

When the water supply has a high hardness, it should be treated before entering the heating system to prevent both scaling (caused by hard water) and corrosion (caused by aggressive water) in the boiler. Please remember that because of their low thermal conductivity, even small scales just a few millimetres thick cause the boiler walls to overheat considerably with serious consequences.

You must treat the water used for the heating system in the following cases:

A) Very large systems (with large volumes of water).

B) Systems where partial or complete draining - and water refilling - are frequent.

4. WIRING AND CONNECTIONS DIAGRAMS

- Electrical connections should be performed according to the diagrams shown below.
- Connect the boiler to a single-phase, phase neutral, 230 V ~ 50 Hz power supply through a standard terminal block or outlet with 2A max. fuses connected between the boiler and the power supply. Remember that the boiler should always be provided with a good earth.

IMPORTANT: The manufacturer disclaims any liability for damage to property or persons caused by failure to earth the boiler correctly.

Electrical connections diagram

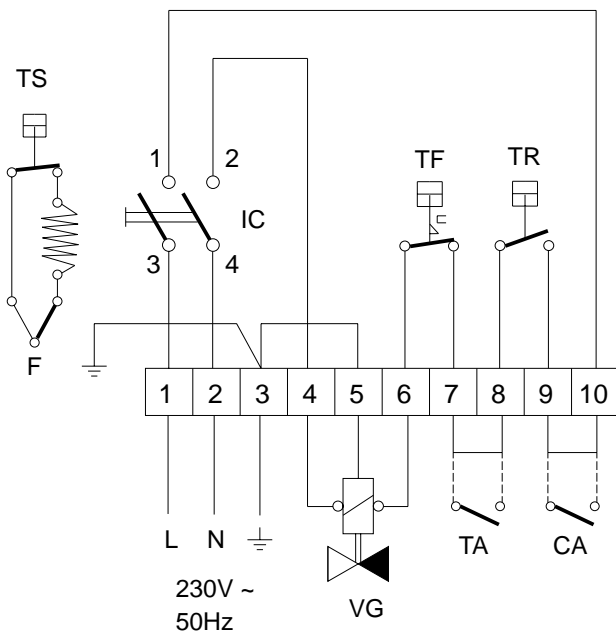

General wiring diagram

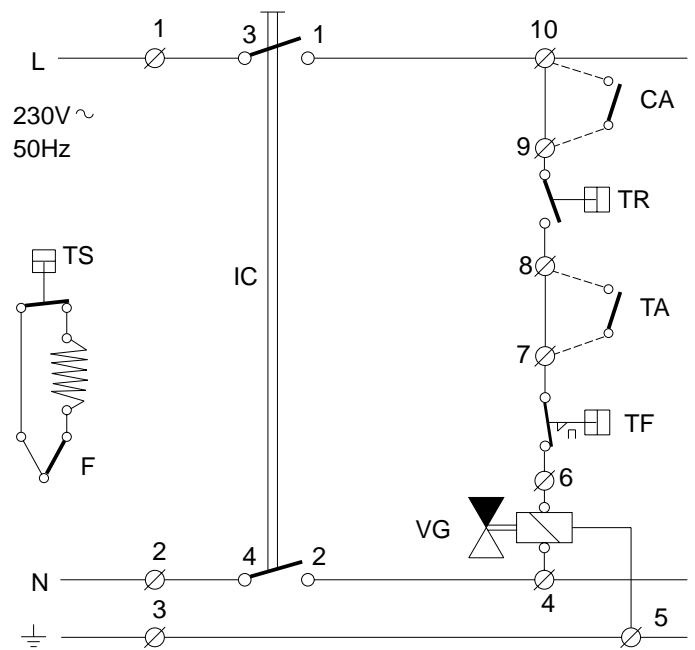

Fig. 5

Key

- IC - Boiler ON/OFF switch
- TA - Room thermostat
- TR - Control thermostat
- TF - Flue gas thermostat
- VG - Gas valve
- TS - Limit thermostat manual re-set
- F - Thermocouple interruptor
- CA - Auxiliary contact

Note: Dotted lines indicate connections to be performed during installation.

4.02 Access to the internal components of the control panel

For access to the terminal block and the internal components of the control panel, proceed as follows:

- a - Switch off the power supply to the boiler.
- b - Lift off the boiler cover (held in place by slot pins).
- c - Unscrew the four screws that hold the plastic panel against the side of the boiler.
- d - Rotate the panel to the front to its locked position.
- e - Carry out the work and reassemble in reverse order.

4.03 Exploded view of the control panel (fig. 6)

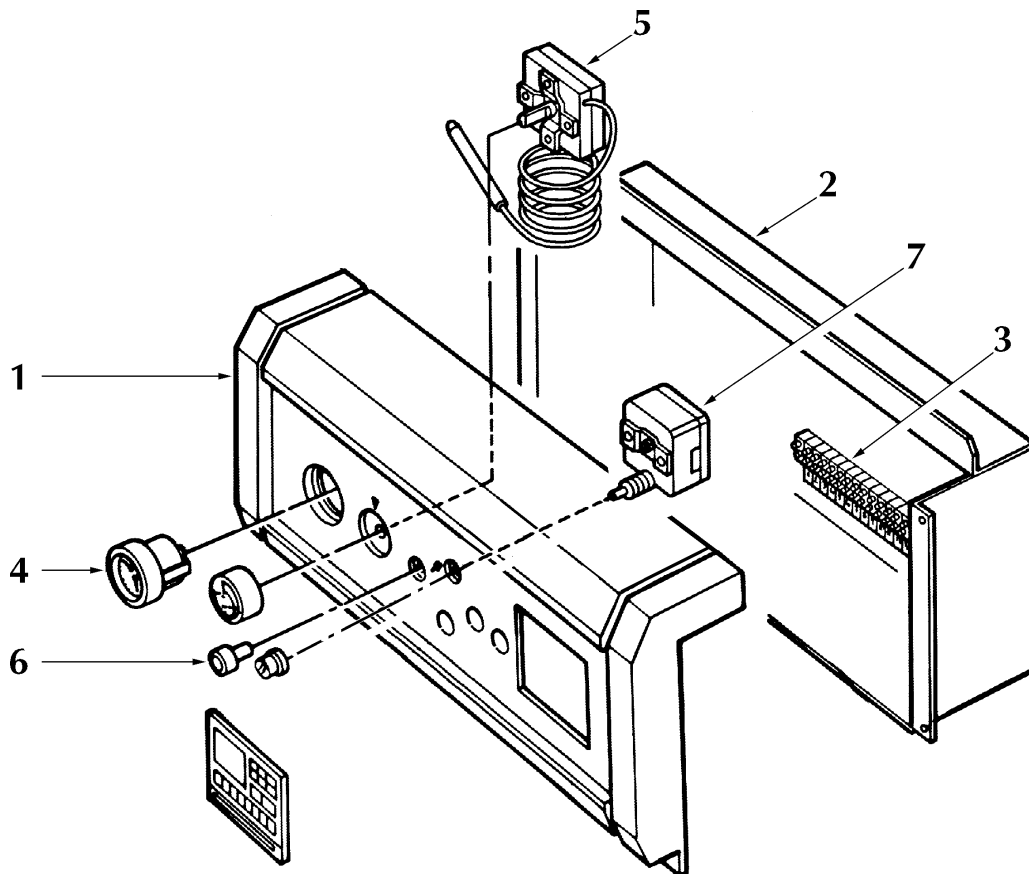

Fig. 6

Key

- | | |
|------------------------------------|-------------------------------|
| 1. Control panel | 5. Control thermostat |
| 2. Wiring harness protection plate | 6. Boiler on/off switch |
| 3. Terminal block | 7. Flue gas thermostat re-set |
| 4. Temperature-pressure gauge | |

5. STARTUP AND SHUTDOWN

5.01 Checks to be carried out on initial lighting

It is good practice to check the following on initial lighting: that the cutoff valves between the boiler and heating system are open; that all is well pressurized and vented; that there are no gas or water leaks from the water system or boiler; that the electrical connections are correct and the earthing cable connected to a good earthing system; that there are no inflammable liquids or materials in the immediate vicinity of the boiler and that the flue is not blocked.

5.02 Startup with the HONEYWELL V4600C valve in models 51-68 (fig. 7a)

Set the boiler control thermostat 2 (fig. 2) to minimum. Switch off the electrical power.

Open the gas cock upstream from the boiler.

Release the air held in the gas pipes by opening the incoming gas valve test point marked with the number 3 (fig. 7a).

Press and keep pressed the gas valve control knob 1.

Ignite the pilot burner by repeatedly pressing the piezoelectric ignition button 12 (fig. 2).

Once the pilot light has been ignited, keep the gas valve knob pressed for another 15 - 20 seconds and then release it slowly checking that the pilot light remains lit. If it does not, wait 30 seconds before igniting it again.

Power up the boiler electric circuit (control thermostat and electrical power).

Set the boiler control thermostat 2 (fig. 2) to the desired temperature (no less than 50°C).

At this point the main burner should ignite and the boiler operate automatically.

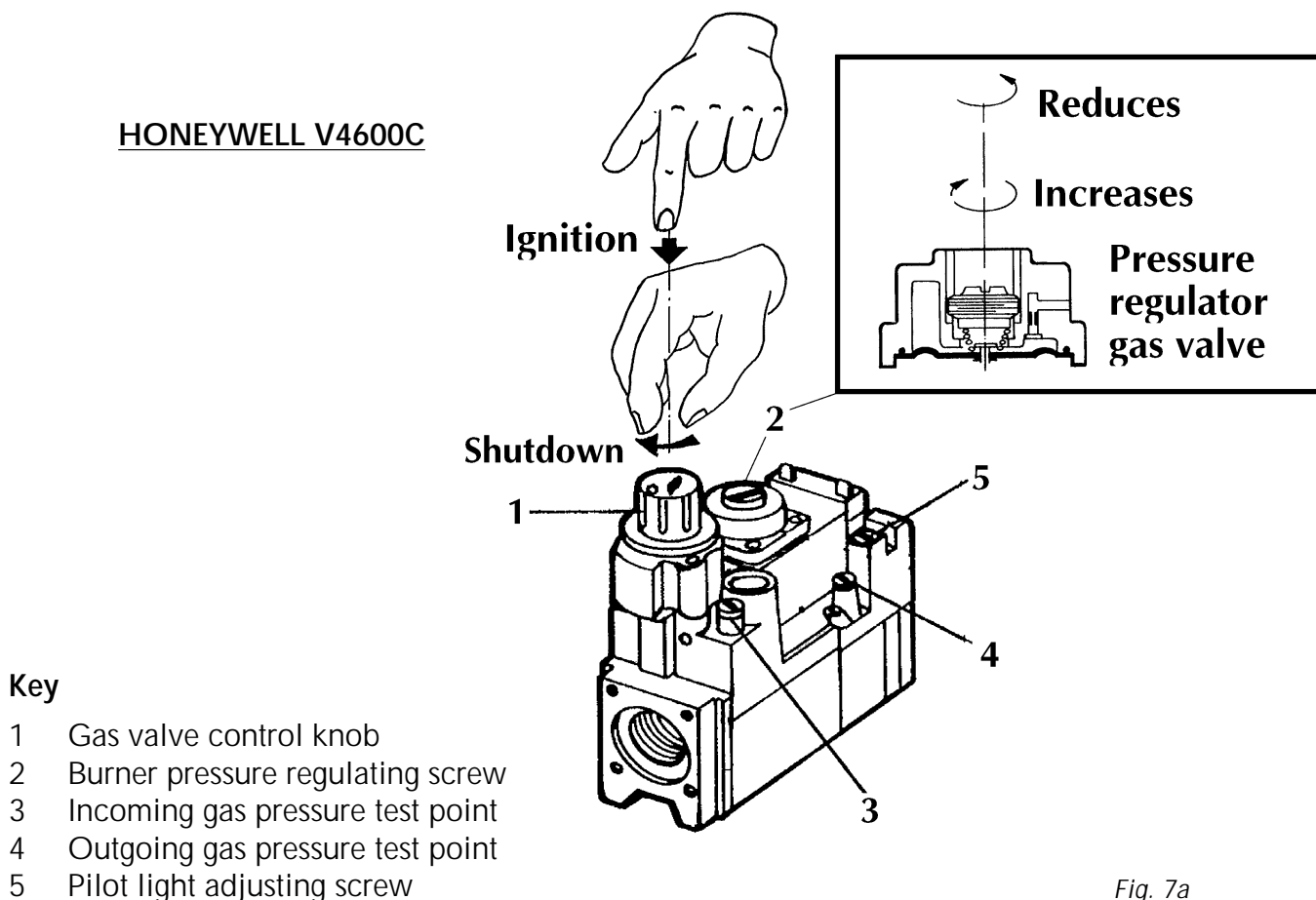

Fig. 7a

5.03 Startup with the HONEYWELL V4400C in models 85-102 (fig. 7b)

Set the boiler control thermostat 2 (fig. 2), to minimum. Switch off electrical power.

Open the gas cock upstream from the boiler.

Release the air held in the gas pipes by opening the incoming gas valve test point marked with the number 3 (fig. 7b).

Press and keep pressed the gas valve control knob "A".

Ignite the pilot burner by repeatedly pressing the piezoelectric ignition button 12 (fig. 2).

Once the pilot light has been ignited, keep the gas valve knob pressed for another 15 - 20 seconds and then release it slowly checking that the pilot light remains lit. If it does not, wait 30 seconds before igniting it again.

Switch on boiler.

Set the boiler regulating thermostat 2 (fig. 2) to the desired temperature (no less than 50°C).

At this point the main burner should ignite and the boiler operate automatically.

HONEYWELL V4400C VALVE

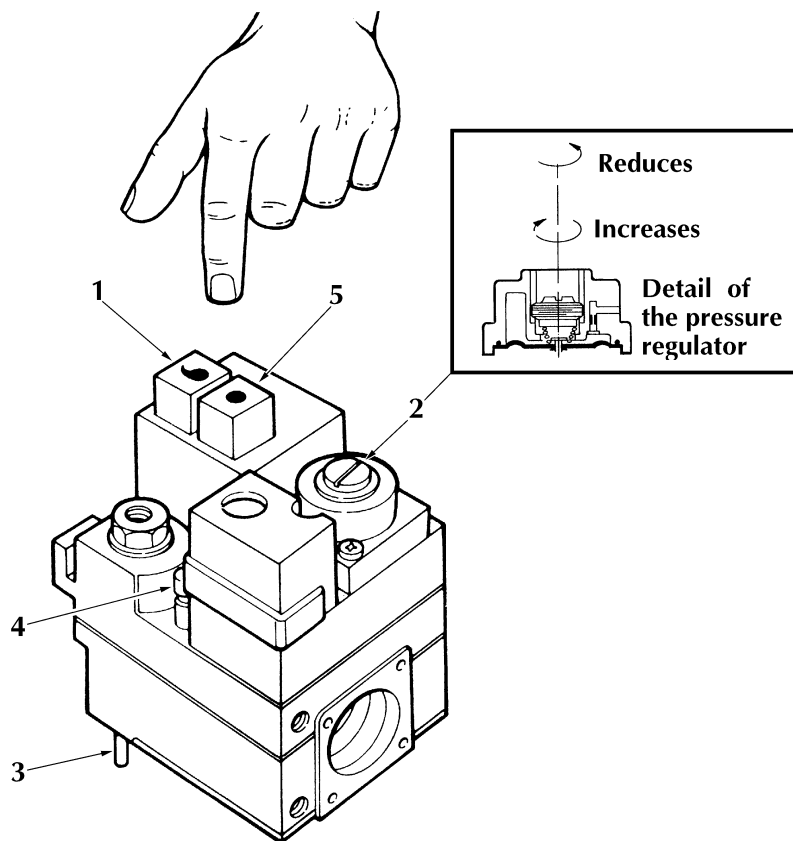

Key

- 1 Ignition button
- 2 Gas pressure regulating screw
- 3 Incoming gas pressure test point
- 4 Pilot light adjusting screw
- 5 Shutdown button

Fig. 7b

5.04 Temporary shutdown

To turn the boiler off for a short period of time, simply switch off the power supply (using the boiler switch). All electrical elements are thus turned off and only the pilot light remains lit.

5.05 Long-term boiler shutdown

Turn knob 1 as indicated in fig. 7a - 7b (in models 51-68), press button 5 as indicated in fig. 7c (in models 85-102). This turns off the flow of gas to both the main burner and the pilot light. Turn off the gas cock upstream from the boiler and switch off the power supply.

5.06 Inspections and controls after startup

At first startup:

- Make sure the gas circuit is perfectly leakproof.
- Make sure the pilot light is adequate and well adjusted; if it is not, adjust it using the gas valve adjusting screw (fig. 7a-7b-7c).
- Test boiler ignition by starting it and turning it off using the regulating thermostat.
- Check that no combustion gas escapes from the rear of the boiler at the height of the draft diverter, indicating that either the flue is blocked or the draft is insufficient.
- Check that the pipe connecting the boiler to the flue is perfectly leakproof at the point of connection between the flue and the boiler.
- Check that gas consumption, measured by the gas meter, matches that indicated in the technical data table.

6. REGULATING

6.01 Adjusting the pressure at the burner

As described above, the boiler is set up to operate on NATURAL GAS (G 20); gas pressure has been tested and calibrated by the manufacturer.

However, due to possible differences in pressure in the gas supply system, at first startup you should check and if necessary adjust the pressure at the injectors to match the pressure level shown in table 3 of the technical data (page 5). Test pressure at test point 11 fig. 2a/2b.

6.02 Gas pressure adjustment and gas conversion with the "HONEYWELL V4600C" valve

Adjust the burner pressure at the main burners by turning screw 2 (fig. 7a): turn it clockwise to increase the burner pressure and anticlockwise to decrease it. (burner pressure test point 11 fig. 2a/2b).

The pilot light may be adjusted by eye, without the use of instruments, by checking that the flame correctly envelopes the thermocouple without burning excessive gas. To adjust the flame, turn screw 5 (fig. 7a). To convert the boiler from NATURAL GAS to LPG, besides replacing the injectors you should carefully set the pressure regulating screw 2 all the way in.

6.04 Gas pressure adjustment and gas conversion with the "HONEYWELL V4400C" valve

Adjust the burner pressure at the main burners by turning screw 2 (fig. 7C): turn it clockwise to increase the pressure and anticlockwise to decrease it. (burner pressure: test point 11 fig. 2a/2b).

The pilot light may be adjusted by eye, without the use of instruments, by checking that the flame correctly envelopes the thermocouple without burning excessive gas. To adjust this flame, turn screw 5 (fig. 7C).

To convert the boiler from NATURAL GAS to LPG, besides replacing the injectors you should carefully set the pressure regulating screw 2 all the way in.

REMEMBER: The complete LPG conversion kit is supplied on request only.

6.05 Replacing the main and pilot burner injectors.

Caution: The following adjustment and conversion operations are to be performed by qualified personnel only.

To replace the main and pilot injectors proceed as follows:

Turn off the gas and switch off the power supply to the boiler.

Replace the main and pilot injector taking care not to damage the main injectors sealing gaskets. If they have been damaged, replace them.

Re-assemble with care.

Adjust the gas pressure at the main injectors, and the pilot flame.

Check that the boiler functions properly and that there are no gas leaks.

6.06 Pilot burner assembly

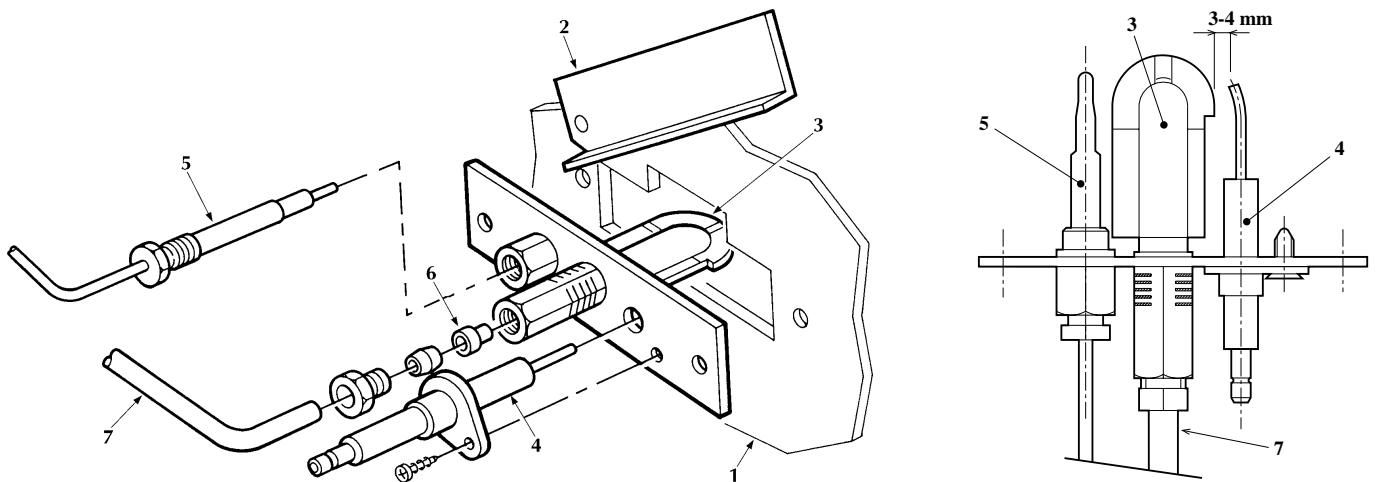

Fig. 8

Key

- | | | | |
|---|---------------------------|---|------------------|
| 1 | Burner plate | 5 | Thermocouple |
| 2 | Pilot light viewing cover | 6 | Pilot injector |
| 3 | Pilot burner | 7 | Pilot gas supply |
| 4 | Ignition electrode | | |

7. MAINTENANCE AND CLEANING

The following operations are to be performed by qualified personnel only. We recommend you contact our local Customer Technical Support Centers.

7.01 Seasonal inspection of the boiler and flue

Before the beginning of winter you should perform a general inspection of the boiler, heating system and flue. The inspection should verify:

- That the boiler sections, burner and flue are clean.
- That the water in the system is at the correct pressure.
- That all control and safety devices operate properly.
- That the thermocouple and ignition electrode are free of carbon deposits.
- That the pilot flame correctly envelopes the thermocouple.
- That circulation pumps are free running.
- That there gas leaks.
- That the gas flow rate and pressure are correct.

7.02 Cleaning the boiler and the flue

To clean the boiler and the flue, remove the burner unit from the boiler.

For access to the cast-iron heat exchanger, proceed as follows (fig. 9): Remove the cover of the casing secured by slot pins; pull out the insulation covering the draft diverter, remove the flue collector inspection cover 2 and its insulation, secured with self-tapping screws 1.

Now you may clean all the flue gas passages in the boiler using a brush 3. Remember you should check and if necessary clean the flue and its connection to the boiler. Be careful not to damage the flue gas thermostat phial or capillary.

Important - Do not clean the burners with chemicals or a steel brush, as these might change the air-gas mixture outlet holes. When cleaning is complete, re-assemble carefully and in the correct position. Then check the seal along the gas and flue gas circuits, functioning of the control and safety devices and gas pressure and gas flow rate.

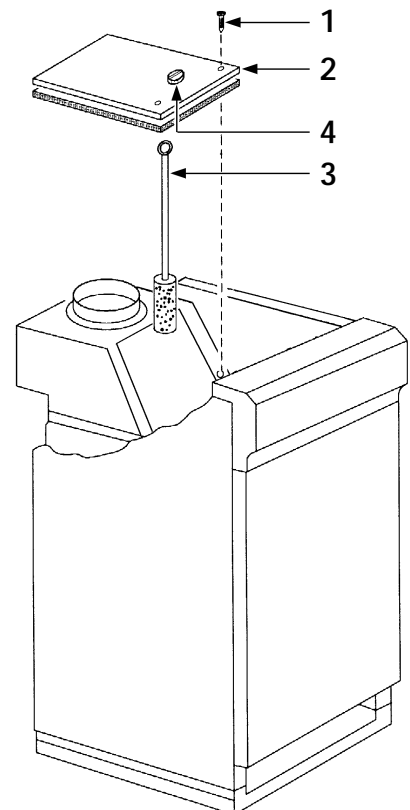

Key

- 1 Securing screws
- 2 Inspection cover with insulation
- 3 Cleaning brush
- 4 Flue gas sampling point

Fig. 9

9. FAULT FINDING

Fault

Cause and Corrective Action

No ignition spark

Piezoelectric igniter failure.

Replace the igniter.

Spark electrode is broken or badly positioned.

Replace the electrode or position it correctly (see fig. 8).

Faulty contact between terminal and cable.

Screw the terminal tightly onto the igniter cable.

No pilot ignition

No gas.

Open the gas cock.

Air is held in the pipes.

Vent it as described in the chapter on startup.

Pilot injector is clogged.

Clean the injector (with compressed air).

Gas flow rate is insufficient.

Adjust flow rate by turning the screw on the gas valve.

Poor pilot flame

The flame has been adjusted wrongly.

Check that the gas inlet pressure is correct.

Pilot burner is dirty.

Clean the pilot burner (with compressed air).

Pilot light goes out

Thermocouple is faulty.

Check and replace the thermocouple.

Insufficient flame.

Adjust the flame, turning the screw on the gas valve, until it envelopes the thermocouple.

Loose contact with the gas valve.

Tighten the connection to the gas valve.

No ignition of main burner

No power supply.

Switch the power on.

Nozzles are clogged.

Carefully clean the nozzles.

Gas valve is faulty.

Repair or replace gas valve.

Flue gas thermostat switched off.

Check the flue for any obstructions, then manually reset the flue gas thermostat.

Instable main burner

Lack of gas.

Check the gas pressure at the main burner.

Boiler is dirty.

Inspect and clean the boiler body.

	<p>Burner is dirty. <i>Inspect and clean the burner.</i></p>
Main burner burns poorly	<p>Flame is not adjusted properly. <i>Adjust the gas pressure at the main burner (see table 3 page 5).</i></p>
Smell of unburnt gas	<p>Boiler is dirty. <i>Inspect and clean the boiler body.</i> Flue draft is insufficient. <i>Check flue draft.</i> Air ventilation is insufficient. <i>Increase ventilation in the room.</i> Flame has been adjusted too high. <i>Check the gas flow rate and gas pressure at the main burner.</i></p>
No rise in temperature while the boiler is working	<p>Flame is not adjusted properly. <i>Check that gas consumption is correct.</i> Boiler is dirty. <i>Inspect and clean the boiler body.</i> Output is too low. <i>Check that the boiler model matches the heating system requirements.</i></p>
Control thermostat restarts high temperature differential	<p>Control thermostat has broken down. <i>Replace the thermostat.</i> Thermostat bulb is outside its sheath. Check that the bulb is inserted in place.</p>
Condensation in boiler	<p>Control thermostat is adjusted incorrectly. <i>Raise the thermostat temperature.</i> Gas flow is insufficient. <i>Check that gas flow conforms to data in table 3 (fig. 2).</i></p>
Boiler becomes dirty quickly	<p>Flame is adjusted incorrectly. <i>Check that the main burner flame is adjusted properly and that gas flow is in proportion to boiler output.</i></p>
Boiler shuts off for no apparent reason	<p>Flue gas thermostat switched off. <i>Inspect the flue draft for obstructions, then reset the flue gas thermostat manually.</i> Safety thermostat switched off. <i>The boiler water temperature has exceeded safe operating temperature.</i></p>

Remember - To avoid unnecessary expenses, before contacting Technical Support, make sure that any boiler failure is not due to the absence of electric power or gas.



ALL SPECIFICATIONS SUBJECT TO CHANGE

Lichfield Road, Branston Industrial Estate, Burton Upon Trent, Staffordshire DE14 3HD
Tel. 08707 282 885 - Fax 08707 282 886
