



THR 10-50



C H A U D I E R E S

la chaleur haute fidélité

CONTENTS

I	- GENERAL PRESENTATION	4
1	- DESCRIPTION	4
II	- TECHNICAL SPECIFICATIONS	5
1	- CHARACTERISTICS.....	5
2	- PIPE CONNECTION DIAMETERS.....	6
3	- DIMENSIONS	6
III	- OPERATION	7
1	- PRINCIPLE.....	7
1.1	- Components	7
1.2	- Control panel	8
1.3	- Operating diagram	9
1.4	- Principle of air/gas servo-control system	10
1.5	- Air pressure variation procedure	10
1.6	- Emission of pollutants	10
2	- THE DIFFERENT VERSIONS OF THE THR	10
2.1	- The basic THR model (no outside sensor or room sensor)	10
2.2	- THR with outside sensor only	10
2.3	- THR with outside temperature sensor and room sensor	11
3	- FUNCTIONS COMMON TO THE DIFFERENT VERSIONS	13
3.1	- Antifreeze function (with QAC31 or/and QAA70)	13
3.2	- Anti-legionella function	13
3.3	- Pump run-on after the end of heating	13
3.4	- Bypass valve and pump kick	13
3.5	- Boiler overheat protection	13
3.6	- Anti-short burner cycle protection function	13
3.7	- Functions activated using the control panel	13
4	- HEAT EXCHANGER/CONDENSER.....	14
5	- . GAS VALVE.....	14
6	- DIGITAL DISPLAY.....	15
6.1	- Normal operation	15
6.2	- List of display codes	15
6.3	- List of alarm codes	16

IV - INSTALLATION	17
1 - GENERAL.....	17
1.1 - Location of boiler	17
1.2 - Gas supply	17
1.3 - Flueing	17
1.4 - Air supply	18
1.5 - Water circulation system	18
1.6 - Electrical supply	18
2 - ANGLE MOUNTING	18
3 - SPACER BACK PLATE (SUPPLIED AS AN OPTION)	19
4 - PLUMBING CONNECTIONS.....	19
4.1 - Pressure/flow rate curves	19
4.2 - Water conditioning in closed multimetal circuits	20
4.3 - Floor heating installation	20
5 - COMBUSTION PRODUCT FLUEING	21
5.1 - Evacuation using standard flue (model B23)	21
5.2 - Evacuation using balanced flue	22
5.3 - Evacuation using horizontal balanced flue (model C13)	24
6 - GAS CONNECTIONS.....	27
7 - ELECTRICAL CONNECTIONS	27
7.1 - Connecting QAC31 outside sensor and QAA70 room sensor options	27
7.2 - Additional functions	27
7.3 - Wiring diagram	28
V - COMMISSIONING	29
1 - COMMISSIONING.....	29
2 - OPERATING PRESSURE CHECK	29
3 - GAS /CO ₂ /CO/NO _X FLOW CHECK.....	30
4 - CONVERSION SET.....	31
4.1 - Conversion from Natural gas H to LPG	31
4.2 - Conversion from LPG to Natural gas H	31
4.3 - Adjustment process	31
VI - MAINTENANCE	32
VII - DOMESTIC HOT WATER TANKS	33
1 - ELECTRICAL CONNECTIONS	33
2 - HYDRAULIC CONNECTIONS.....	33
3 - OPERATING PRINCIPLE.....	34
VIII - REGLEMENTATION	35
1 - DECLARATION OF CONFORMITY	35

1 - DESCRIPTION

This is a wall-mounted condensing boiler, with a heat output, with a closed circuit hot-water heating boiler, type B₂₃, C₁₃, C₃₃, with a linear power modulation, and a premixed burner with an air-gas servo-control system, meeting the PREN 483 (12.97) and EN 487 (02.94), and PREN 677 (03.96):

- EC type approval N° CE-0085AR0323.
- Gas certification DVGW - VP 112 (01.95) N° Q 022/003.
- Blue Angel Label.

The power output is controlled by an integrated electronic regulator according to the heating system's requirements. The gas/air ratio is controlled by a servo-valve system which maintains the correct mixture across the full operating range.

A cover with a calm, restrained styling contains the following components:

- A high performance condensing heat exchanger made from tubular fins.
- A variable-speed fan (230 V AC - 50 Hz - 39 V DC) controlled by the regulator.
- A premixed burner with a heat resistant stainless steel grate.
- A 24 Volt gas valve unit with dual air pressure valve control.
- A heating circuit safety valve (3 bar).
- A condensate siphon trap.
- "Overheat" safety cut-out with manual reset (100 °C).
- Water pressure sensor.
- "Flue gas overheat" safety cut-out with manual reset (85 °C).
- A circulating pump.
- A microprocessor-based control panel for providing boiler regulation and ensuring smooth running:
 - Flame ionization monitoring.
 - Radiator temperature adjustment.
 - Pressure display.
 - Operating sequence display.
 - Fault display.
 - On/off switch.

II - TECHNICAL SPECIFICATIONS

1 - CHARACTERISTICS

Type THR				THR 10-50	
EC approval				CE0085AR0323	
Category				II ₂ H3P	
	T° heating	Connection	Setting		
Heat output	30/50 °C	B ₂₃	min./max.	kW	10,6/50,5
	30/50 °C	C ₁₃ /C ₃₃	min./max.	kW	10,6/47,8
	60/80 °C	B ₂₃	min./max.	kW	9,5/47,0
	60/80 °C	C ₁₃ /C ₃₃	min./max.	kW	9,5/44,5
Max. Heat input				kW	10,0/50,0
Efficiency on NCV	30/50 °C		min./max.	%	106,0/101,0
	60/80 °C		min./max.	%	95,0/94,0
Efficiency on GCV	30/50 °C		min./max.	%	95,4/91,0
	60/80 °C		min./max.	%	85,5/84,6
Gas used					
Combustion products temperature				°C	80
Gas rate combustion products			min./max.	kg/h	18,0/90,0
Admissible back pressure (Combustion products)	B ₂₃		max.	Pa	0
	C ₁₃ /C ₃₃			Pa	100
NO _x				mg/kWh	< 60 (Angel Blue Label)
CO				mg/kWh	< 50 (Angel Blue Label)
Heating water pressure				bar	1/3
Max. Heating water temperature				°C	75
Boiler water capacity				litre	3,8
High				mm	760
Width				mm	765
Depth				mm	355
Weight		Without water		kg	70,0
		With water		kg	73,8
Electrical supply/Frequency					230 V (+ 10%, - 15%)/50 Hz
Electrical power consumption in Heating function		min./max.		W	245
Indice IP		models C ₁₃ /C ₃₃			IP 44
		model B ₂₃			IP 24
Wall losses at 70 °C				W	190

2 - PIPE CONNECTION DIAMETERS

Combustion products:	Ø 80	(item. 1, fig. 1)
Gas inlet:	1"	(item. 2, fig. 1)
Heating flow:	1"	(item. 3, fig. 1)
Heating return:	1"	(item. 4, fig. 1)
Condensate drain:	Ø 25 PVC	(item. 5, fig. 1)
Pressure relief valve:	Ø 27	(item. 6, fig. 1)
Possibility of connection for a second heating circuit:	1"	(item. 7, fig. 1)

3 - DIMENSIONS

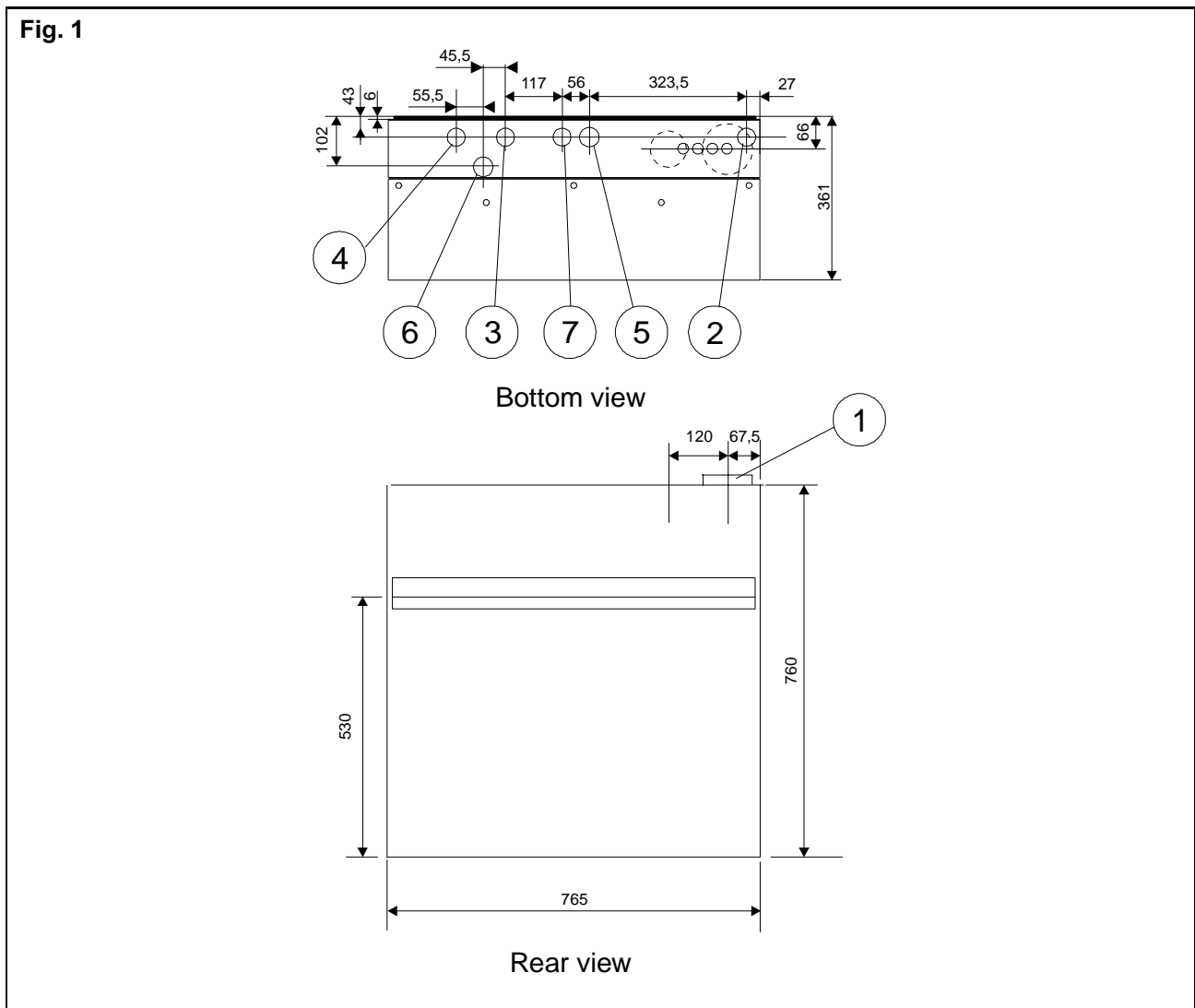

III - OPERATION

1 - PRINCIPLE

1.1 - Components

Fig. 2

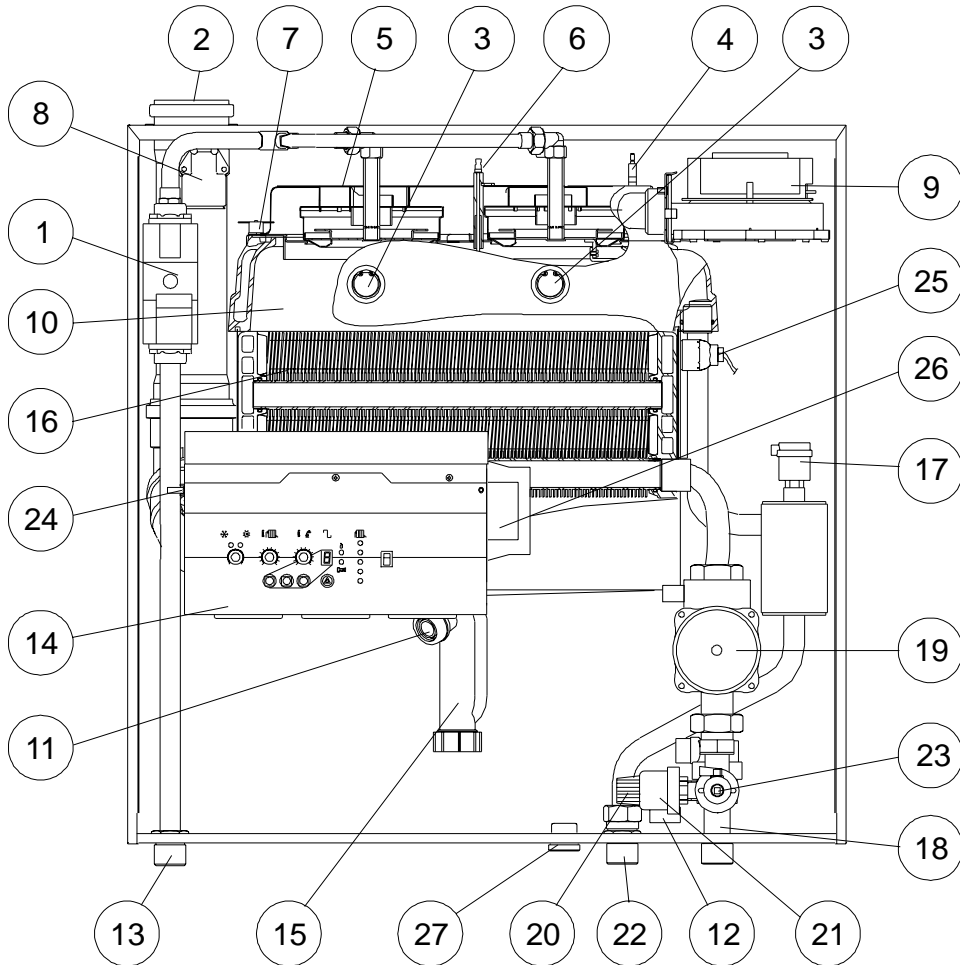

- | | |
|--|---|
| 1) 24 V gas valve (solenoid valve and regulator) | 15) Siphon trap |
| 2) Combustion product flueing | 16) Finned tube heat exchanger |
| 3) Sight glass | 17) Air vent |
| 4) Ignition electrode | 18) Heating return manifold |
| 5) Gas burner | 19) 230 V 3 speed circulating pump |
| 6) Ionization probe | 20) Pressure relief valve (3 bar) |
| 7) Overheat safety thermostat 100 °C | 21) Water pressure sensor |
| 8) 24 V ignition transformer | 22) Heating flow |
| 9) 39 V/230 V fan | 23) Drain cock and filter |
| 10) Combustion chamber unit | 24) Flue gas safety cut-out 85 °C |
| 11) Condensate drain | 25) Heating sensor |
| 12) Pressure relief valve drain tube | 26) Mains transformer 230 V |
| 13) Gas supply | 27) Connection of a 2nd heating circuit |
| 14) Microprocessor-based control panel | |

1.2 - Control panel

Fig. 3

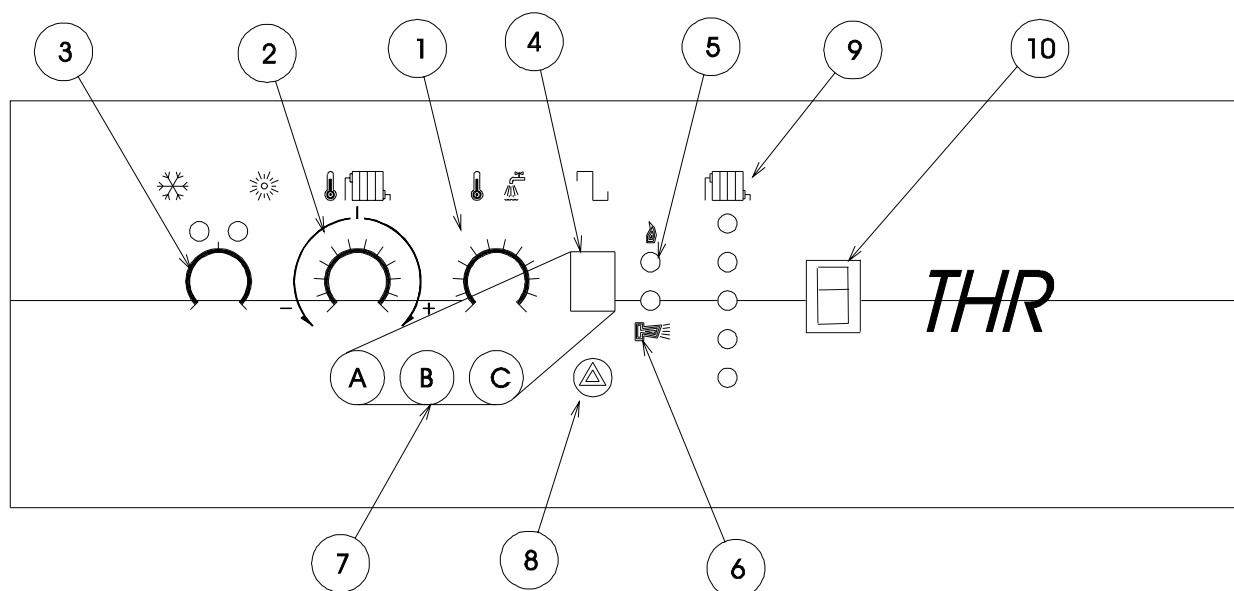

- | | |
|--|--|
| 1) A domestic hot water temperature control potentiometer (§ 2 - III - OPERATION) | 7) Three buttons (A, B and C) reserved for installer's use (or for modifying heating characteristics: § 2.2.2 - III - OPERATION) |
| 2) A heating temperature control potentiometer, also a warm/cool control potentiometer for model THR with outside sensor (§ 2 - III - OPERATION) | 8) A reset button for use if a fault occurs |
| 3) Winter/summer switch (winter: heating + hot water, summer: hot water only) (On the dual function model only) | 9) A system for displaying the water pressure in the heating network |
| 4) A sequence display | 10) An on/off switch |
| 5) A flame indicator lamp | |
| 6) A fault indicator lamp | |

1.3 - Operating diagram

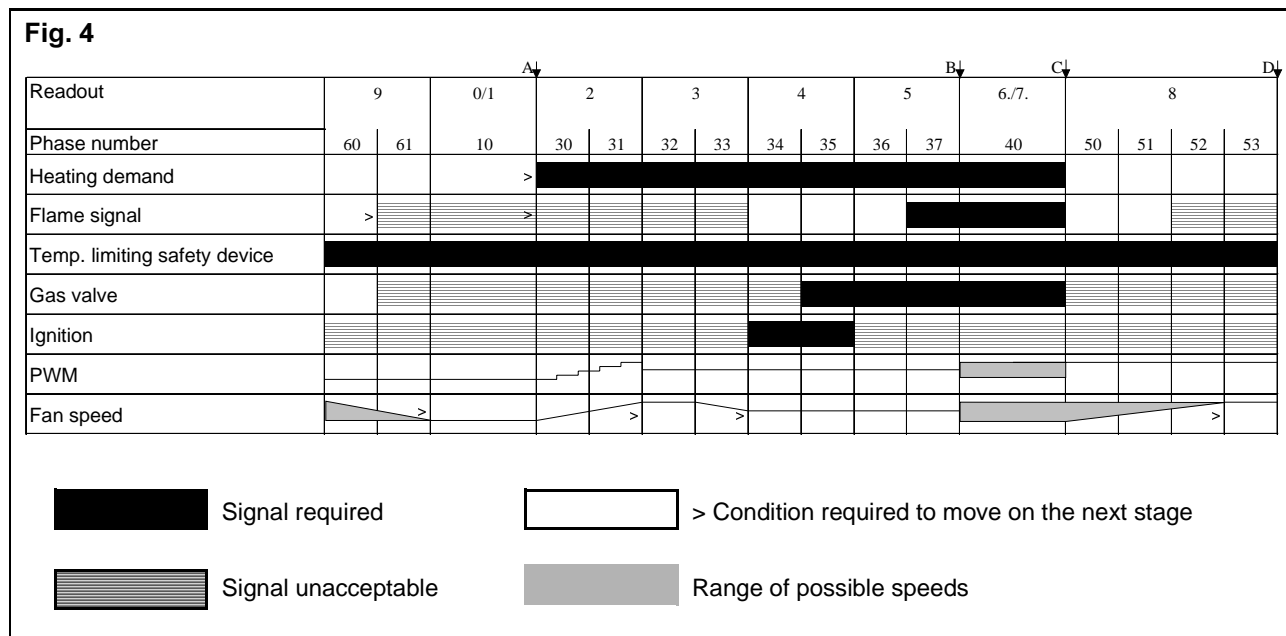

Programme sequence:

- Phase 10: STANDBY:

The boiler is on standby awaiting a demand for heat.

A: Start-up instruction.

I is given by the boiler regulator or by the domestic hot water regulator.

- Phase 30-31: Fan speed rise time:

This time ends as soon as the fan motor speed reaches the load programmed for prevention.

- Phase 32: Prevention time.

- Phase 33: Tapering time:

This time ends as soon as the programmed ignition load is reached.

- Phase 34: Pre-ignition time (3 s):

Appearance of the ignition arc prior to opening the gas valve, which occurs at the start of phase 35.

- Phase 35-36-37: Safety time (3 s):

A flame signal should be present (ionization current > 2.8 μ A) before the safety time has elapsed. If this does not occur, another ignition attempt is made.

- Phase 40 (B-C): Burner operation:

Burner operation following a demand for hot water (display 6) or heating (display 7).

- Phase C-D: Shut-down:

The change of operating position to standby is referred to as a "shut-down" and occurs when the demand for heat disappears. The gas valve closes and the combustion residues are evacuated by post-ventilation.

- Phase 50-51: Blocking time:

Blocking time, for test purposes (about 2 s).

- Phase 52: Closure time:

Time required to arrive at the programmed air flow rate.

- Phase 53: Post-ventilation time (3 s):

The fan remains on during the post-ventilation phase.

- Phase 60-61: Return to initial position:

Obligatory passage from the shut-down position to standby. This phase is also used to bring the gas control box to the standby position after exceptional events such as a reset.

1.4 - Principle of air/gas servo-control system

The THR boiler's gas valve is controlled by the air pressure supplied by the fan, thus guaranteeing a correct air/gas ratio over the whole range of operation (constant CO₂). The ratio remains constant despite any pressure drop in the combustion products outlet or the air intake. The air-gas link is pneumatic.

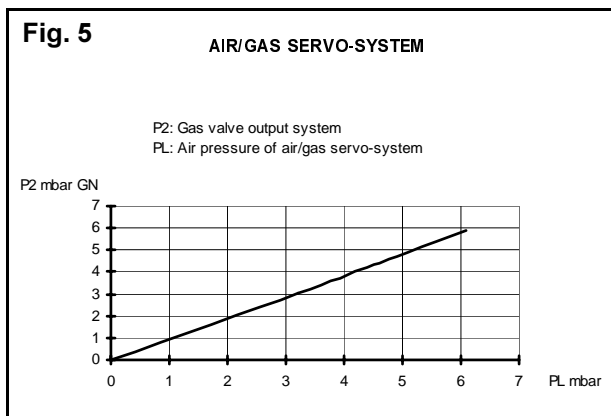

1.5 - Air pressure variation procedure

The THR boiler has a 230 volt variable-speed fan; It is controlled by the regulator, which calculates the speed needed at any given time to produce the required pressure.

1.6 - Emission of pollutants

The THR boiler is fitted with a high performance pre-mixed burner.

CO and NOx emissions are within the values laid down by the most demanding quality standards. (Blue Angel label).

2 - THE DIFFERENT VERSIONS OF THE THR

2.1 - The basic THR model (no outside sensor or room sensor)

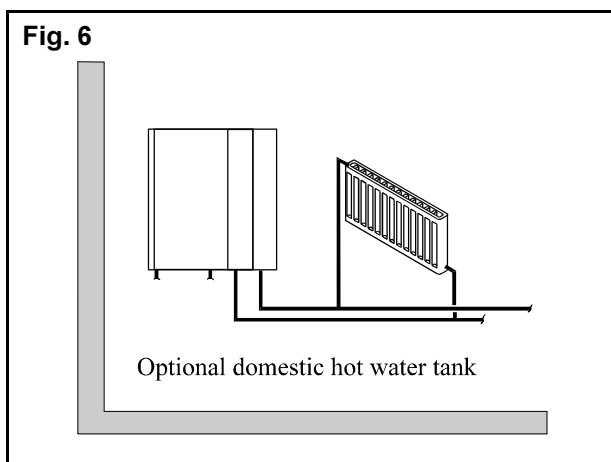

Manual adjustment of heating flow and domestic hot water temperatures (if optional hot water tank included) on the boiler control panel.

The heating regulator defines the heat output required to achieve the heating and hot water settings entered by the user. These are set using temperature knobs for the boiler flow and hot water settings. A winter/summer switch can be used to switch from hot water only (summer position) to heating and hot water (winter position).

Whether the switch is set to winter or summer, the boiler is protected against freezing when the temperature drops below 5 °C.

2.2 - THR with outside sensor only

Correction of flow temperature and adjustment of hot water temperature (if optional hot water tank included) on the boiler control panel.

2.2.1 - Principle

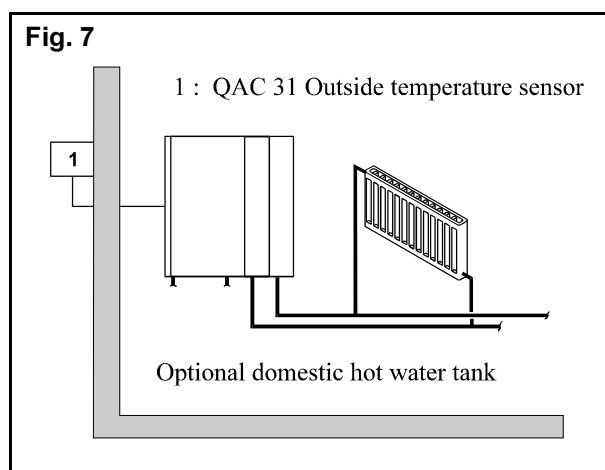

The hot water temperature setting is adjusted using the hot water temperature control knob on the control panel.

Winter/summer switch set to the winter position, the regulator automatically switches between winter and summer. The boiler provides only hot water when the average outdoor temperature exceeds 19 °C. Otherwise, the boiler provides heating and hot water.

When the winter/summer switch is set to the summer position, the regulator provides hot water only.

The temperature control knob becomes inactive; In effect the heating flow temperature is regulated as a function of the real outdoor temperature conditions. This is achieved using the heating curves integrated into the regulator itself.

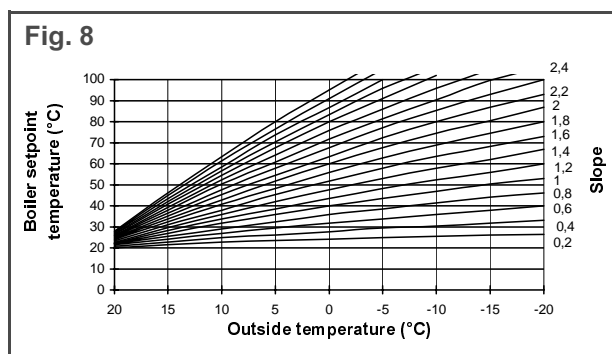

The slope of this curve is preset to an average value, but can be corrected using the heating knob and button C (both located on the control panel) to correct it to warmer or cooler (shifted parallel).

Once this parameter has been set, your heating system becomes completely independent¹ and will produce ambient temperatures that are finely calculated to give the optimum operating yield.

2.2.2 - Modifying heating parameters

2.2.2.1 - Floor heating

The heating curve slope is factory-preset to 1.5 to cater for heating by radiator.

This value needs to be changed to 0.8 when used with floor heating:

- Press the three buttons A, B and C simultaneously until a **flashing L** appears on the display, followed by a **flashing I I**.

The slope has now been corrected. It is however possible to refine the following parameters according to the precise needs of the installation (see § 2.2.2.3 - III - OPERATION) by increasing or reducing the temperature setting by a few degrees.

2.2.2.2 - Radiator heating

The factory settings correspond to heating by radiator. The characteristics of the building (e.g. insulation, heating surface) may mean that the setting need adjusting in order to obtain a higher or lower level of heating. This involves modifying the heating curve parameters (see § 2.2.2.3 - III - OPERATION).

1. The heating flow temperature varies automatically according to the outside temperature.

2.2.2.3 - Modifying parameters

Adjust the heating knob to the right to obtain a warmer temperature setting (room temperature warmer) (max. + 3 °C) and to the left for a cooler setting (max. - 3 °C). Press button **C** until an **F** appears on the display (about 3 s). The parameters have now been adopted by the system.

If the radiator temperature setting needs to be increased by more than 3 degrees, this operation can be repeated, but first wait for 10 minutes to allow the regulator time to register the new parameters properly. The inherent inertia in buildings and their heating systems means that it may take several hours to react to a change, so it is better not to change this parameter too often.

To return to the standard parameters, press the three buttons **A**, **B** and **C** simultaneously until an **L** appears on the display.

2.3 - THR with outside temperature sensor and room sensor

All the controls, settings, overrides and corrections for heating flow/hot water temperatures (if optional hot water tank included) can be carried out using the room sensor.

2.3.1 - Principle

This version is designed to provide optimum comfort. As well as the functions linked to the outside sensor described for the model above, the system also has a room sensor.

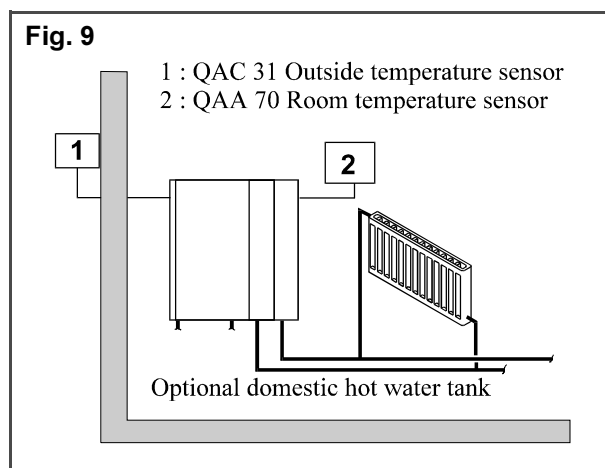

This QAA70 room sensor provides the following functions:



- Compensation for ambient conditions.
- The ability to programme three daily periods for heating or hot water.
- A easy programme override to switch the system off either momentarily or for longer periods (e.g. holidays).

- An ambient temperature setting for each programmed period.
- A setting for the hot water temperature.
- A display showing the time, the outside temperature, the ambient temperature, the boiler temperature, the hot water temperature and indicating the presence of any faults on the boiler system.
- The ability to anticipate and defer water heating: The hot water tank will start being fed with hot water one hour before the heating period and this will continue until 10 minutes after the end of this period. When a demand for domestic hot water is made during a period of reduced heating, the boiler systematically ensures that the water is at the hot water temperature setting.

2.3.2 - Adjustments

Fitting the QAA70 module on the boiler cancels the functions of the heating and hot water temperature knobs on the boiler control panel. The expected temperatures must be set on the QAA70 sensor (see separate technical instructions).

2.3.2.1 - Winter/summer switch

When the winter/summer is switch set to the winter position, the boiler can switch automatically from winter to summer operation. Summer operation is active when the outside temperature measured over the previous 24 hours exceeds the set point by 1 °C, i.e. it reaches 20 °C. When summer operation is active it can be overridden temporarily by pressing simultaneously the  and  buttons on the QAA70.

The system also automatically returns to summer operation, this time when the outside temperature measured over the previous 24 hours is at least 1 °C less than the set point, i.e. below 18 °C. The 19 °C set point can only be changed by using the AZW75 interface.

When the winter/summer switch is set to the summer position, the regulator provides hot water only (if the boiler has a hot water tank).

Buttons A, B and C operate on the integrated regulator and are used to access special functions common to all versions.

2.3.2.2 - Ambient conditions compensation function

This function can be used to correct the boiler flow temperature according to the real ambient temperature measured by the QAA70 sensor. The function should be activated or deactivated when the boiler is commissioned depending on the position of the sensor. The function should be inactive if any of the following apply: if the QAA70 is placed outside the

heated space or in a room with another heating system, or if it is exposed to sunshine, or if thermostatic valves are set on the radiators in the room where the QAA70 is fitted. When the ambient conditions compensation function is inactive, the QAA70 becomes a remote control acting on the heat curve to cater for the drop in temperature from daytime to night-time.

- *Activating the ambient conditions compensation function:*

Press buttons **A** and **C** simultaneously for 5 seconds until the symbol  appears on the display.

- *Deactivating the ambient conditions compensation function:*

Press buttons **A** and **C** simultaneously for 5 seconds until the symbol  appears on the display.

2.3.2.3 - Auto-adapt function

This function automatically corrects the heating curve based on a measurement of the real ambient temperature. The corrected loss can be read via the AZW75 "apprentice parameters" interface.

The function should not be active in the installation situations described above for the ambient conditions compensation.

- *Activating auto-adapt:*

Press buttons **B** and **C** simultaneously for 5 seconds until the symbol  appears on the display.

- *Deactivating auto-adapt:*

Press buttons **B** and **C** simultaneously for 5 seconds until the symbol  appears on the display.

3 - FUNCTIONS COMMON TO THE DIFFERENT VERSIONS



For these functions to work (anti-freeze, pump kick, automatic winter/summer switching, anti-legionella etc.), the on/off switch must not be operated (needs to be kept permanently in the “on” position).

3.1 - Antifreeze function (with QAC31 or/and QAA70)

Antifreeze protection for the boiler: When boiler temperature is below 5 °C the burner and the heating circuit pump are switched on. When the temperature increases and exceeds 15 °C the burner is disconnected and the pump continues to circulate for 10 mins.

Antifreeze protection for the installation: The heating pump starts operating automatically either intermittently or continuously depending on whether the external temperature is under 1.5 °C or under -10 °C.

Antifreeze protection for the house : When the boiler is equipped with a QAA70. Protection is provided by maintaining ambient temperature at a minimum of 5 °C.

Antifreeze protection for domestic hot water: When hot water production has shut down, a minimum temperature of 4 °C is guaranteed by the regulator.

3.2 - Anti-legionella function

To provide a degree of protection against the development of pathogenic bacteria in the hot water tank during prolonged shut-downs, the domestic hot water needs to be heated once a week to above 60 °C.

The anti-legionella function is used for this purpose. It heats the hot water storage tank once a week to an “anti-legionella” temperature of 65 °C.

3.3 - Pump run-on after the end of heating

When heating ends, the circulating pump remains on for a further 10 minutes.

In hot water storage systems, when water heating ends, the circulating pump remains on until the boiler temperature drops below 70 °C. During this pump run-on period, the by-pass valve remains in the “domestic hot water feed” position.

3.4 - Bypass valve and pump kick

If during shut-downs either the heating circuit has not operated or the bypass valve has not been switched for more than about 24 hours, these are activated for a period of about 5 seconds.

3.5 - Boiler overheat protection

The regulator incorporates a temperature control function; This can switch off the burner when the temperature of the water in the boiler reaches the maximum of 85 °C. The circulating pump remains on until the real temperature of the water in the boiler drops below 79 °C. The burner is then allowed to start up again.

A boiler overheat protection also exists.

When the safety thermostat activates, the heating circuit circulating pump and the fan motor are switched on for 10 minutes. The bypass valve switches to the “heating” position.

This second safety system requires a manual reset and generates an alarm on the boiler. The reset button has to be pressed to return to normal operation.

3.6 - Anti-short burner cycle protection function

The minimum time that the burner can operate is set to 60 seconds.

3.6.1 - Adapting to an external solenoid safety valve

When using liquefied gas, the system can be adapted at output ST9 to use an external solenoid safety valve.

Index 5 signalling output is programmed as follows:

Index 5 bit 7	Index 5 bit 6	Index 5 bit 1	Index 5 bit 0
1	0	0	0 or 1

Output ST9 is on from phase 30 (fan speed rise time) to phase 50 (regulator ends heat demand).

Supply: AC - 230 V + 10 % / - 15%
I < 1,0 A ; cosφ > 0,8

3.7 - Functions activated using the control panel

3.7.1 - Sweep function (display code: "5")

The sweep function is activated by pressing **B** for at least one second, i.e. when a demand for heating is made so that the system comes on. The regulator's internal “on-off” functions remain inactive in this situation. The heating then operates at maximum heat output until the temperature controller responds (to take the sweep function flue gas measurements).

3.7.2 - TÜV Function (display code: "4")

Pressing **A** and **B** for at least one second activates the TÜV function, i.e. the internal regulator/temperature controller function becomes inactive. The heating then operates at maximum heat output until the safety temperature limiter responds (STB). Releasing either of the two buttons interrupts the TÜV function.

3.7.3 - Regulator off function (display code: flashes "7")

Pressing **A** only for at least 3 seconds activates the "regulator stop" function. This allows the fan speed (and therefore the heat output) to be adjusted manually on the hot water setting potentiometer (e.g. for adjusting the gas orifice, etc.). The boiler then operates in its heating regime; the internal "on-off" regulator and the temperature controller function are active.

The regulator off function is ended by pressing the button again or by switching off the burner.

4 - HEAT EXCHANGER/CONDENSER

An oversized heat exchanger/condenser, with a water-cooled combustion chamber in its upper part, combines the functions of a heat exchanger and condenser.

Condensation occurs on the tube walls where the temperature is below the dew point for the combustion products.

Efficiency curve at high/low setting:

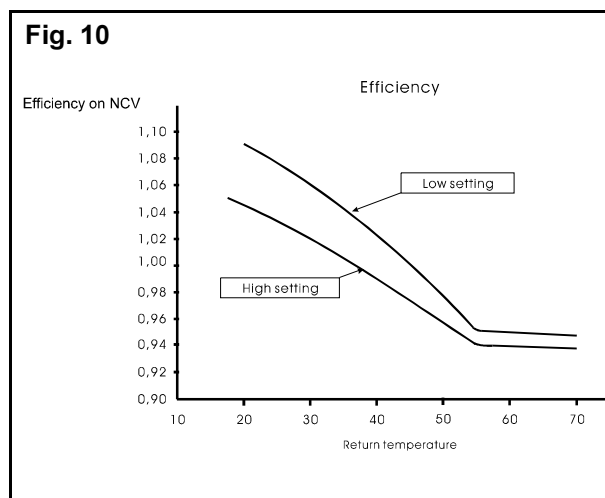

5 - . GAS VALVE

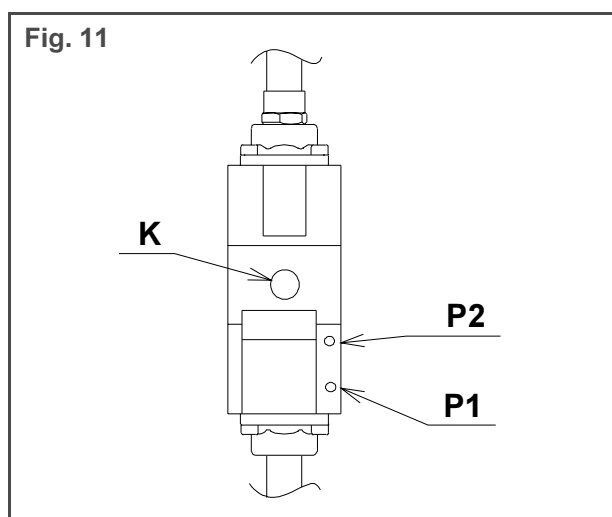

P_1 = Inlet gas pressure

P_2 = Regulator outlet gas pressure

K = Adjustment screw used to produce a parallel shift in the gas characteristic. This screw is factory preset. Its adjustment should not be changed, even for a change of gas. If however it should prove necessary to adjust it, this must only be done **on the low setting** using a small scale pressure gauge (0 to 10 mmWG) and a CO_2 & CO analyzer. Screwing clockwise increases the pressure measured at P_2 .

6 - DIGITAL DISPLAY

6.1 - Normal operation

Display	Meaning
0	Awaiting demand for heating or hot water
1	Shunt 6 not present switch open
2-3	Fan speed rise time/Preventilation
4	Pre-ignition - Ignition
5	Flame presence verification
6	Burner operating on hot water
7	Burner operating on heating
8	End of demand for heating or hot water, post-ventilation
9	Return to initial position, reinitialise gas control box parameters (fan off)

6.2 - List of display codes

The ALARM LED remains off, the segment display flashes. If several signals occur, the code with the highest priority is displayed.

Display	Meaning	Priority
1	Boiler potentiometer setting absent	1
2	Hot water potentiometer setting absent	1
4	TÜV function active	1
5	Sweep function active	1
7	Regulator off function active	1
8	Domestic hot water sensor 1: Circuit broken	1
0	Domestic hot water sensor 1: Short circuit	1
A	Anti-legionella function active	2
C	Sweep button closed after RESET/Unlock	1
d	TÜV button closed after RESET/Unlock	1
E	Forced intermission active	2
F	Warmer/cooler correction executed	1
L	Revert to standard values	1
P	Q1 heating circuit pump kick active	2
U	Q3 hot water pump or bypass valve kick active	2

6.3 - List of alarm codes

Display flashes (item. 4, fig. 3)/led on (item. 6, fig. 3).

Display	Fault	Possible cause/solution
0	Incorrect fan speed during preventilation phase	Check parameter DA3
2	Overheat thermostat or flue gas thermostat activated	Check water pressure and flow (Pmin. = 1 bar). Purge the installation correctly
4	Flame fault or premature flame signal	<ul style="list-style-type: none"> - The flame does not appear: no gas, gas valve will not open, significant gas valve adjustment error, defective HT transformer, HT lead, or HT electrode - The flame only appears for 3 seconds: Live/neutral reversed, defective ionization probe or ionization probe lead
5	Incorrect fan speed at maximum load	Check parameter DA4
6	Fan speed rise time too long	Check that the fan is able to rotate freely
9		
A	Maximum fan speed exceeded during preventilation phase	<ul style="list-style-type: none"> - Check mains voltage (too high) - Check that neither the flue nor the fan air inlet are blocked. - Check parameter DA.
H	Boiler sensor circuit broken	Replace boiler sensor
L	Boiler sensor circuit broken	Replace boiler sensor
C	Boiler water pressure too low	<ul style="list-style-type: none"> - Check the water pressure in the heating circuit - Check that the pressure sensor is working - accessed by removing the plastic cover.

All other codes result from internal faults.

IV - INSTALLATION

1 - GENERAL

Installing a wall-mounted gas boiler presents no particular difficulty.

The installation of the boiler must be carried out by a competent person in accordance with the relevant requirements of the Gas Safety (Installation and Use) Regulations, Building Regulations, Model Water Byelaws and the Building Standards (Scotland) Regulations. It must also comply with the current I.E.E. Wiring Regulations and the relevant recommendations of the following British Standard Codes.

Regulations and the relevant recommendations of the following British Standard Codes of Practice:

- CR331.3
Low pressure installation pipes.
- BS.5449.1
Forced circulation hot water systems.
- BS.5546
Installation of gas hot water supplies for domestic purposes.
- BS.5440.1
Flues (for gas appliances of rated input not exceeding 60 kW).
- BS.5440.2
Air supply (for gas appliances of rated input not exceeding 60 kW).
- BS.6798
Boilers of rated input not exceeding 60 kW.

Note:

- The boiler is only suitable for installation in a sealed system and must not be used with an open vented system.

1.1 - Location of boiler

The boiler can be installed on the inner face of an external wall - and some internal walls - providing they are flat, vertical and capable of adequately supporting the weight of the boiler and any ancillary equipment.

The boiler may be installed in any room or internal space, although particular attention is drawn to the requirements of the current I.E.E. Wiring Regulations and, in Scotland, the electrical provisions of the Building Regulations applicable in Scotland with respect to the installation of the boiler in a room or internal space containing a bath or shower. Where installation is in a room containing a bath or shower, any electrical switch or boiler control utilizing mains electricity should be situated so that it cannot be touched by a person using the bath or shower.

Where installation will be in an unusual location, special procedures may be necessary and BS.6798 gives detailed guidance on this subject.

A compartment used to enclose the boiler **MUST** be designed and constructed specially for this purpose. An existing cupboard or compartment may be used provided it is modified for the purpose. Details of essential features of cupboard/compartment design, including airing cupboard installations, are given in BS.6798.

In siting the boiler, the following limitations **MUST** be observed:

- The position selected for installation **MUST** allow adequate space for servicing in front of the boiler and for air circulation around the boiler.
- This position **MUST** also permit the provision of a satisfactory balanced flue termination.

Note:

- If the boiler is to be fitted in a timber framed building, it should be sited in accordance with the British Gas publication "Guide for Gas Installations in Timber Frame Housing". Reference DM2. If in doubt, advice must be sought from the Local Gas Region of British Gas.

When siting the boiler, provision must be made for the disposal of the condensate, see Section 4 - Condensate drain.

The pressure relief valve connection should be routed to an external, visible point where the discharge of steam or water cannot create a hazard to persons or property. BS.5449: 1 refers.

1.2 - Gas supply

Installation pipes should be fitted in accordance with CP.331.3.

The complete installation must be tested for soundness and purged in accordance with CR331.3.

1.3 - Flueing

Detailed recommendations for flueing are given in BS.5440.1. The following notes are intended for general guidance.

1.4 - Air supply

1.4.1 - For room-sealed systems

Detailed recommendations for air supply are given in BS.5440.2. The following notes are intended for general guidance.

Where the boiler is to be installed in a room or internal space, the boiler does not require the room or internal space containing it to have a permanent air vent.

Where the boiler is to be installed in a cupboard or compartment, permanent high and low level air vents are required for cooling purposes in the cupboard or compartment. Both vents must communicate with the same wall to outside air.

The minimum effective area of the permanent air vents required in the cupboard or compartment are given in next Table "air vent areas".

Position of air vents	Air from room or internal space	Air direct from outside
High level	186 cm ²	93 cm ²
	29 in ²	15 in ²
Low level	186 cm ²	93 cm ²
	29 in ²	15 in ²

1.4.2 - For natural draught system

Detailed requirements are given in BS 5440.2.

1.5 - Water circulation system

The expansion vessel is suitable for systems up to **80 litres** water content. For systems in excess of this capacity an additional pressurized expansion vessel will be required. BS7074 and "British Gas Specifications for Domestic Wet Central Heating Systems" Part 3 gives guidance in this subject.

The central heating system should be in accordance with the relevant recommendations given in BS.6798 and, in addition, for small bore and microbore systems - BS.5449.1. The domestic hot water system, if applicable, should be in accordance with the relevant recommendations of BS.5546.

Copper tubing, to BS. 287 1. 1, is recommended for water carrying pipework.

1.6 - Electrical supply

Wiring external to the boiler must be in accordance with the I.E.E. Wiring Regulations and any local regulations.

2 - ANGLE MOUNTING

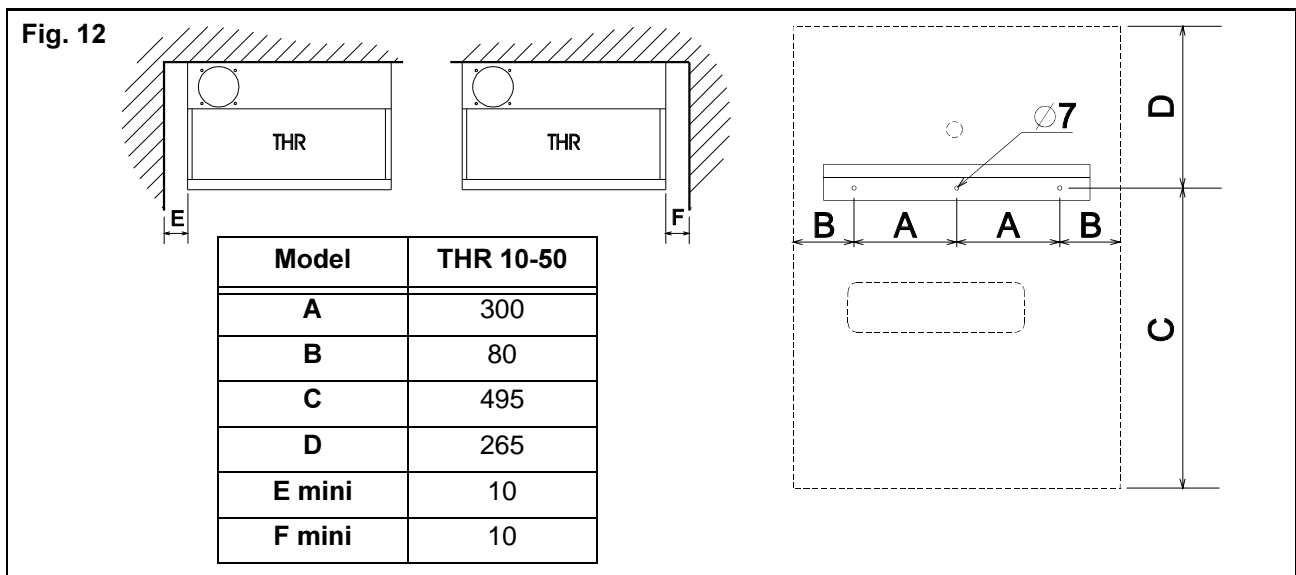

3 - SPACER BACK PLATE (SUPPLIED AS AN OPTION)

The spacer back plate allows the pipes to be fed through behind the boiler when they arrive from above.

Assembly:

- Fit the angle mounting to the wall (supplied with the boiler).
- Hang the spacer back plate on the angle mounting.
- Hang the boiler on to the spacer back plate.

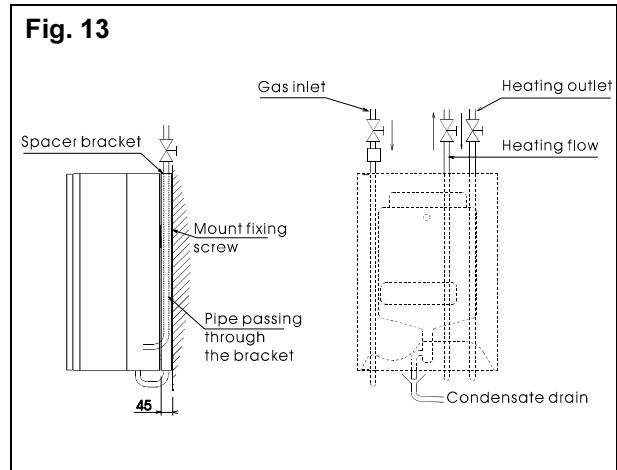

4 - PLUMBING CONNECTIONS

Accessories to be connected:

- **Expansion vessel** (an option) precharged to 0.5 bar suitable for an installation up to 100 litres. (For more than 100 litres provide for additional expansion).
- Heating system **safety pressure relief valve** for connecting to the waste water outlet via a funnel and siphon trap.
- **Condensate drainage siphon trap** for connecting via Ø 25 PVC pipe to the waste water outlet via a funnel and siphon trap. When installing the system, don't forget to fill the siphon traps with water before commissioning. These should be inspected twice a year.
- A **circulating pump** with an air vent. The silicon tube from the purger should be slid inside the funnel.

The heating flow and return pipes must be fitted with stop valves so that work can be carried out on the boiler if required without draining the installation.

Water flow rate through the heat exchanger:

The power delivered by the boiler depends on the water flow rate through the exchanger. This can be set to between 1200 and 2500 litres/hour according to the installation's rated power output.

To ensure that heat transfer operates correctly and to avoid any risk of boiling, never use a flow rate of less than 1200 litres/hour.

4.1 - Pressure/flow rate curves

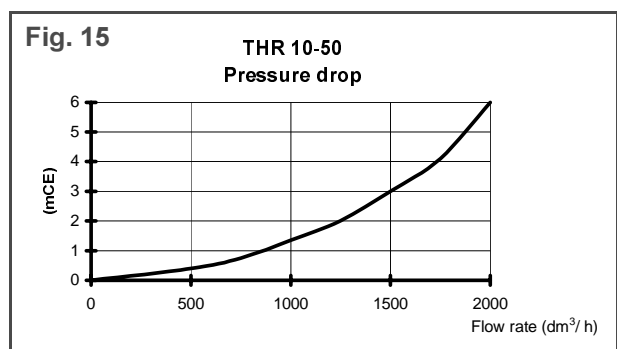
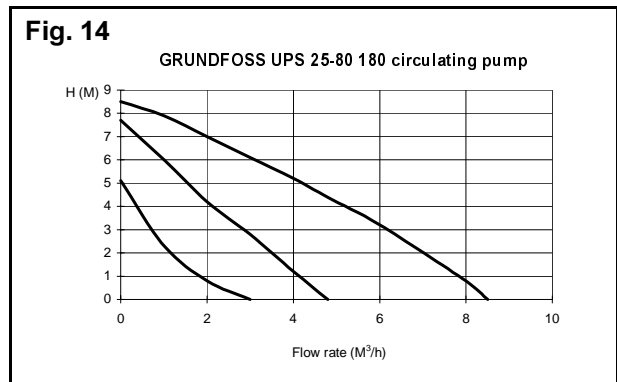

4.2 - Water conditioning in closed multimetal circuits

A water conditioning product is supplied with the boiler.

This must be added to the heating circuit when the installation is filled with water. INIBAL: dose = one litre to one hundred litres. If the installation is not new, ALWAYS flush out the system using clear water before finally filling it.



Antifreeze:

Only use INIBAL ANTIFREEZE, otherwise the boiler heating unit will not be covered under the warranty. INIBAL ANTIFREEZE provides protection against freezing, gassing and multimetal circuit corrosion. If the installation is treated using INIBAL ANTIFREEZE, the conditioning product supplied with the boiler does not need to be added.

Inibal antifreeze dosage:

Number of litres of INIBAL ANTIFREEZE to be added to the central heating circuit to achieve protection down to a given temperature (left hand column in table) against capacity in litres (top row of table).

Temperature protection limit	Installation capacity (litres)																
	10	20	30	40	50	60	70	80	90	100	120	140	160	180	200	250	300
- 8 °C	2	3,5	5,5	7,5	9	11	13	15	17	18	22	26	30	33	37	46	55
- 10 °C	2	4	6,5	9	11	13	15	17	20	22	26	30	35	40	44	55	66
- 12 °C	2,5	5	7,5	10	12	15	17	20	22	25	30	35	40	45	50	62	75
- 14 °C	3	5	8	11	14	16	19	22	25	28	33	39	44	50	55	70	80
- 16 °C	3	6	9	12	15	18	21	24	27	30	36	42	48	54	60	75	90
- 18 °C	3	6,5	9,5	13	16	19	22	26	29	32	38	45	51	58	64	80	96
- 20 °C	3,5	7	10	13	17	20	24	27	30	34	41	48	54	61	68	85	100
- 22 °C	3,5	7	11	14	18	22	25	29	32	36	43	50	58	65	72	90	108
- 24 °C	4	7,5	11	15	19	23	27	30	34	38	41	53	61	68	76	95	114
- 26 °C	4	8	12	16	20	24	28	32	36	40	48	56	64	72	80	100	120
- 28 °C	4	8,5	13	17	21	25	29	34	38	42	50	59	67	76	84	105	126
- 30 °C	4,5	9	13	18	22	26	31	35	40	44	53	62	70	79	88	100	132

4.3 - Floor heating installation

4.3.1 - Basic THR (without sensor)

This THR boiler model cannot be fitted for use in a floor heating system (unless it is installed with an independant electronic control)

4.3.2 - THR with outside sensor only

To operate the THR with outside sensor as part of a floor system, the internal regulator parameters have to be changed when commissioning the system. This modification is explained in § 2.2.2 - IV - INSTALLATION. Incorrect changes to these parameters may cause damage to the installation.

A safety device has to be fitted in order to comply with the regulations. This manual reset device, which is independent from the regulation system,

must cut off the heat supply and should function even in the absence of power or motor fluid. The connection of a switching device to connector No. 6 of the control box satisfies this requirement.

4.3.3 - THR with outside sensor and room sensor

Installing this type of boiler as part of a floor heating system imposes the same constraints as for the previous version, namely that the internal regulator parameters have to be changed (§ 2.2.2 - IV - INSTALLATION) and an independent safety device has to be fitted.

5 - COMBUSTION PRODUCT FLUEING



The flue systems presented in this technical document are those usually used on the European market. However, some of them may not be usable in all EEC countries. It is the responsibility of the installer or building owner to ensure that the selected flue system accords with local installation regulations.

5.1 - Evacuation using standard flue (model B₂₃)

General instructions:

The THR is a condensing boiler, so a sealed flue has to be used. The combustion products are saturated with water vapor which will continue to condense on the tubing walls. The condensate therefore has to be collected at the base of the conduit and fed towards the drain. As the condensate is acidic (pH = 4), the use of a stainless steel conduit is recommended.

Note:

- Avoid horizontal sections where condensation is liable to collect. Always ensure a minimum slope of 2 % is used (low point on boiler side).

Fig. 16

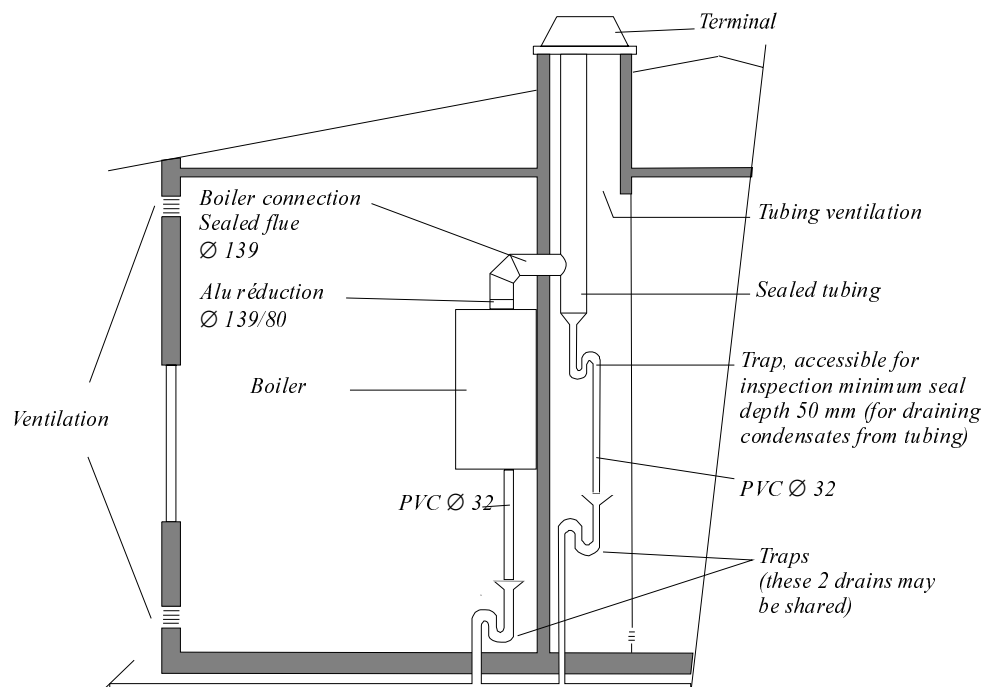

5.2 - Evacuation using balanced flue

Power:

Power is automatically reduced by means of the air/gas servo-control system. No systematic adjustment is required when commissioning the installation. Only the usual CO and CO₂ checks should be carried out (see table in § 3 - V - COMMISSIONING). The maximum ΔP of 100 Pa is obtained with a vertical balanced flue DN 80/125 length 4 metres with two 45° elbows.

General instructions:

The sealed combustion circuit THR boiler connected to a vertical balanced flue is independent of the ventilation conditions in the room where it is installed.

Two concentric tubes supply air to the burner and evacuate the combustion products. The conduits can be bent, allowing the system to be adapted to most installation situations.

The flue terminal cover is specially designed to withstand wind from all directions as well as rain and snow.

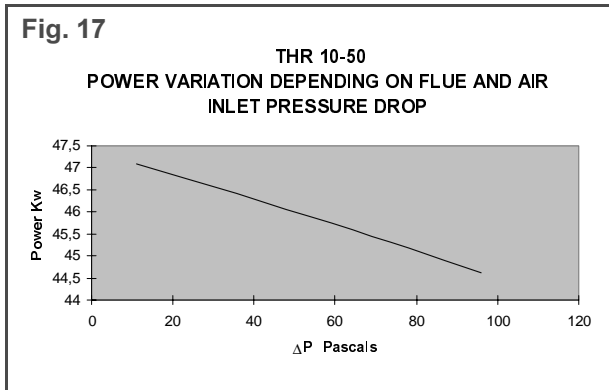

Example assembly:

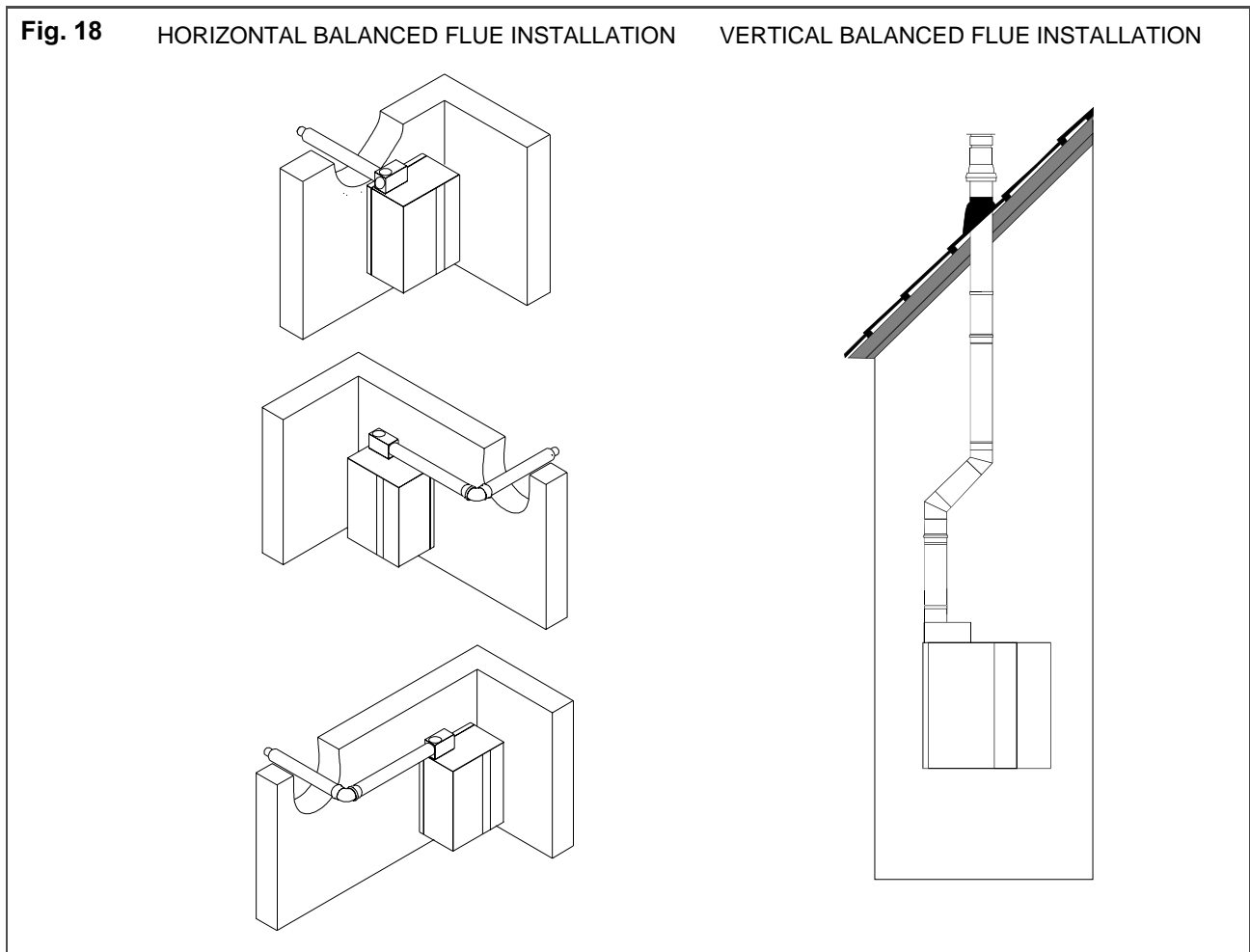

5.2.1 - Evacuation using vertical balanced flue (model C₃₃)

Fig. 19

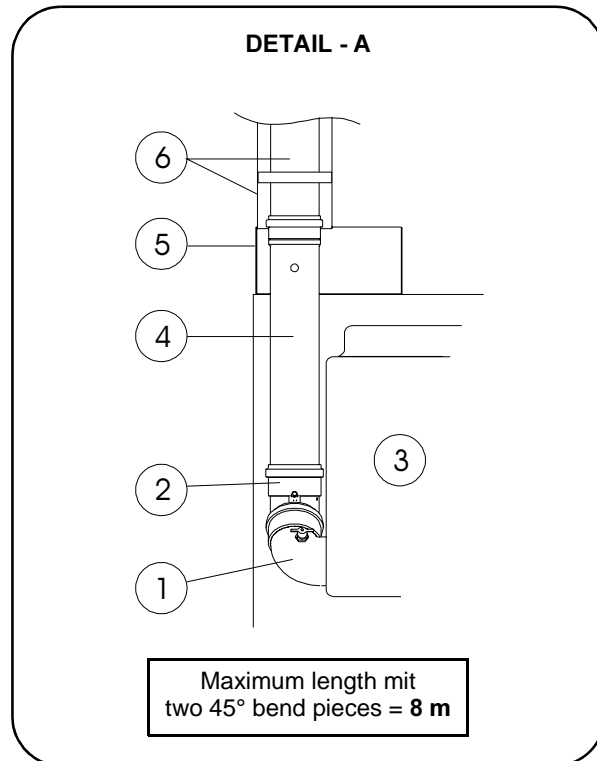
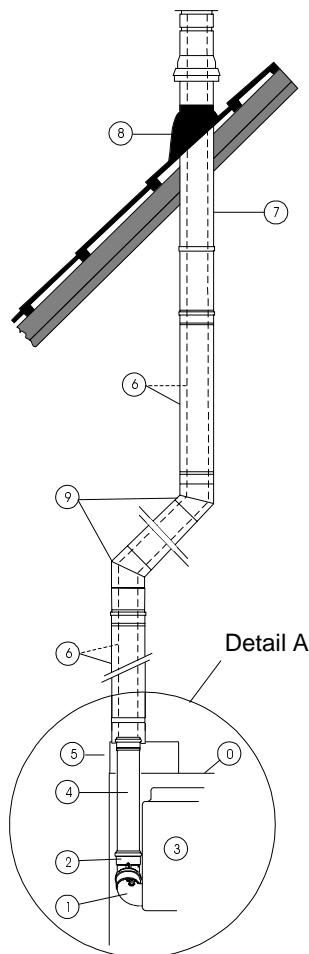

- | | |
|---|---|
| <p>0) Boiler cover</p> <p>1) 90° elbow, PP Ø 80</p> <p>2) 45° elbow, PP Ø 80</p> <p>3) Heating unit</p> <p>4) Tube, PPS Ø 80, L = 505 mm</p> <p>5) Flue casing (Vertical Balanced Flue Kit) (cf. detail A)</p> <p>6) Concentric extension
 Ø int ALU: 80 mm - Ø ext PVC: 125 mm
 Length L = 500 mm or L = 1000 mm</p> | <p>7) Concentric vertical flue terminal
 Ø int ALU: 80 mm - Ø ext PVC: 125 mm
 Length L = 1150 mm (sloping roof)</p> <p>8) Sleeve tile with adaptable coupling according to roof covering type and slope</p> <p>9) Concentric elbow, 45°
 Ø int ALU : 80 mm - Ø ext PVC: 125 mm</p> |
|---|---|

Equivalent configurations:

Each 45° elbow added reduces the maximum length by 0.5 metre.

The maximum temperature of the combustion products is 80 °C.

Product items:

- 1 to 2: supplied with the boiler.
- 4 to 9: need to be ordered specifically.

5.3 - Evacuation using horizontal balanced flue (model C₁₃)

A horizontal balanced flue must be installed when the wall adjoining the water heater is on outside wall in a well ventilated location. The water heater installed in this way possesses a sealed combustion circuit, completely independent of the ventilation circuit for the rooms.

The flue may be mounted to the right, to the left, or directly behind the water heater.

Standard flue length: **1 m**
Maximum length: **4 m**

The balanced flue outlet must be located at least 0.4 m from any opening window and 0.6 m from any air ventilation opening (see regulations). Two balanced flue outlets (from two distinct adjacent THR units) must be at least 0.6 m apart.

The flue gas exhaust tube must slope towards the outside at 1 cm per meter to avoid accumulation of rain water in the vent-air intake system.

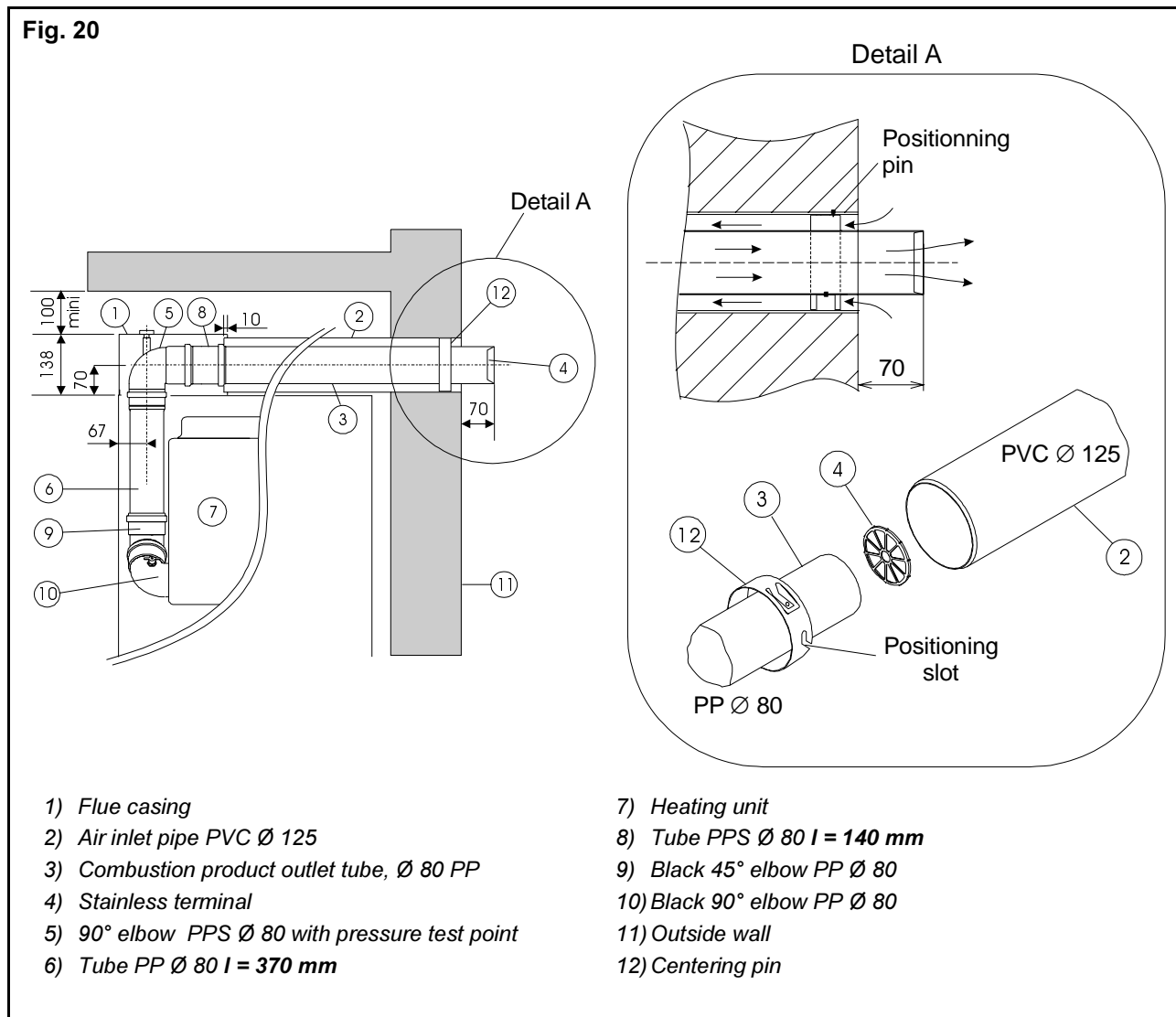

The THR is supplied with a standard length flue which can be used to run through a wall up to 1 meter thick located directly behind the water heater. For greater lengths use the extension tube and elbows in option (see § below).

The THR water heater has a sealed combustion cir-

cuit. Take care to keep the various seals in good condition (cover, flue box, etc.).

Replace if necessary. the various elbows and connection pieces located on the flue gas exhaust route and on the air intake must be fitted in a leaktight manner in order to avoid flue gases recycling.

Fitting a deviated balanced flue:

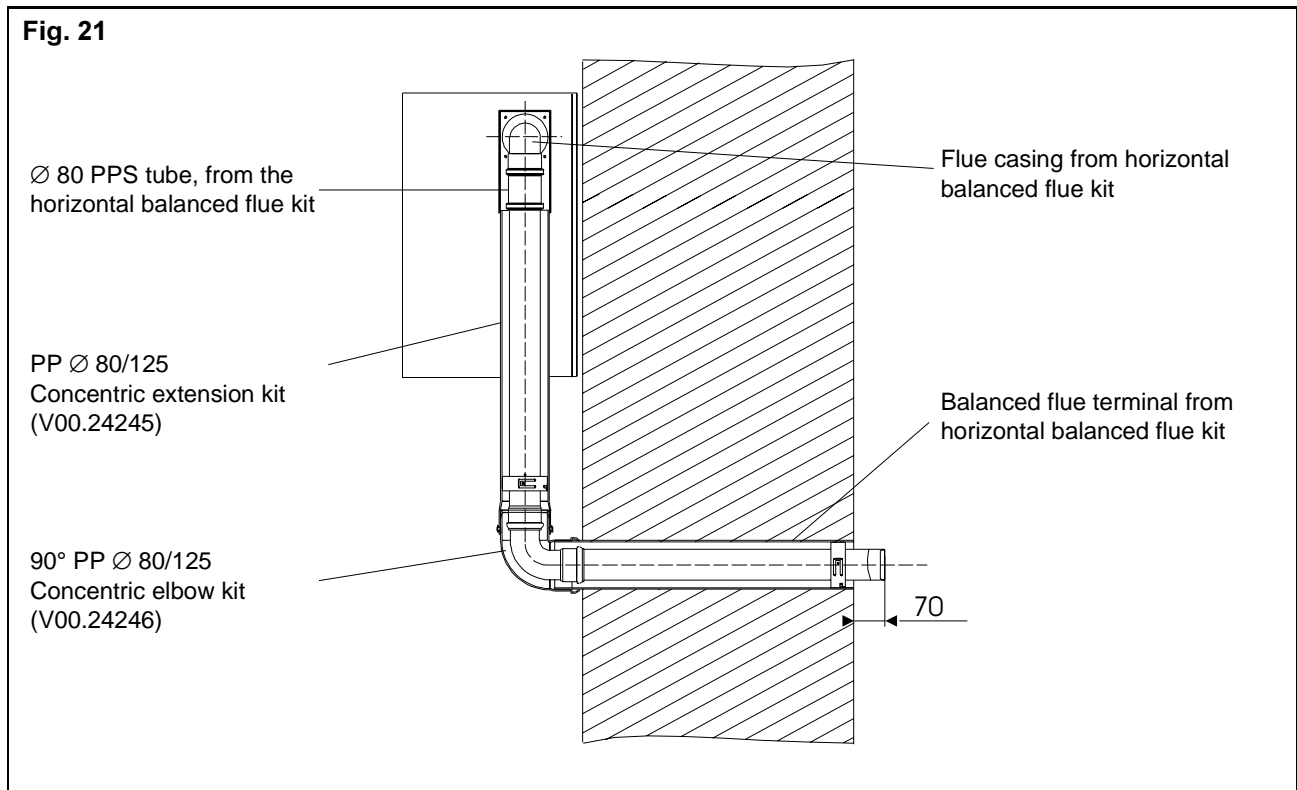

Maximum length of horizontal balanced flue:
4 metres.

One 90° elbow is equivalent to a straight length of one metre.

Thus a balanced flue with a elbow cannot exceed, for example:

2 metres + 2 elbows odder 1 metre + 1 elbow + 2 metres
 (the elbow located at the back of the boiler should not be taken into account).

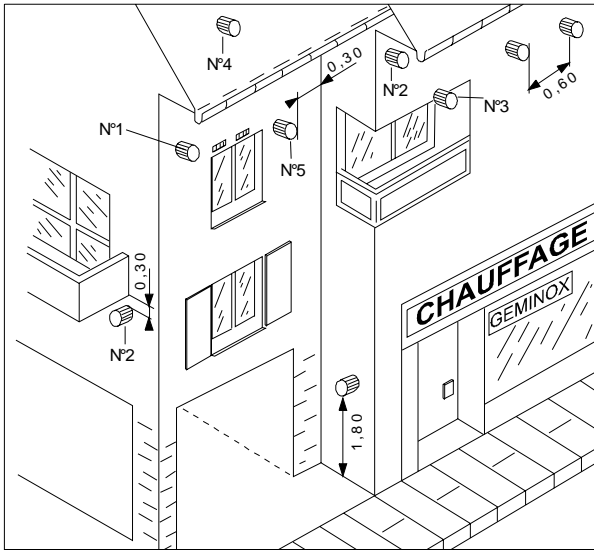

- 1) The three recommended distances (code of practice)
- 2) Outlet under balcony or roof
- 3) Outlet on a balcony
- 4) Roof outlet (refer to factory)
- 5) Outlet near to a corner

All dimensions are the minimum permissible

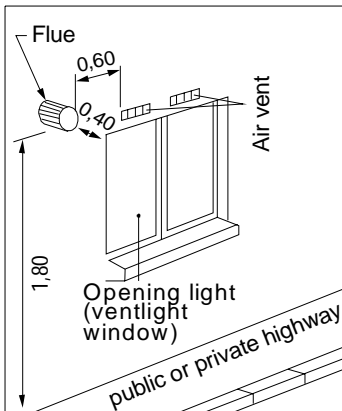

A public or private highway where a flue outlet is located includes :

- public or private pavement
- pedestrianised street
- traffic route
- alleyway
- stairway (including landings and steps)

(No.1)

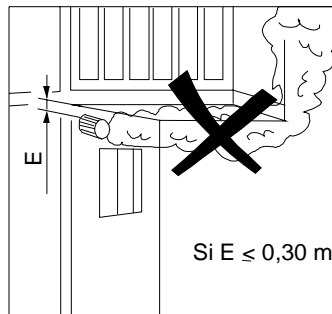

(No.2) Approved extension : 13.12 feet (4m)

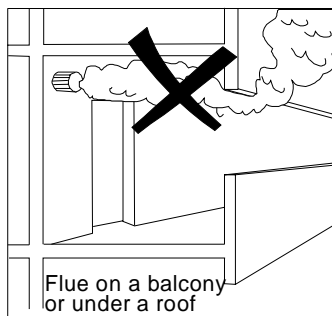
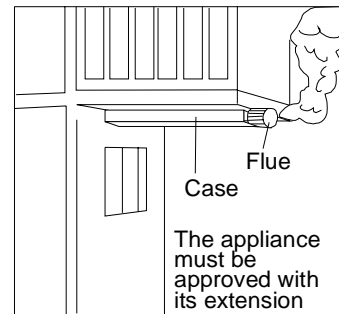

(No.3) Approved extension : 13.12 feet (4m)

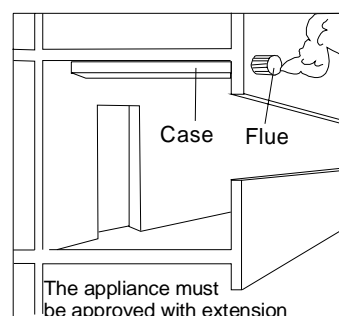

6 - GAS CONNECTIONS

- The gas supply diameter is 1".
- With natural gas, a gas stop valve in conformity with Gas Regulation has to be installed on the boiler gas supply pipe in an easily accessible location. With propane, the 37 mbar release mechanism that acts as a gas cock must also be accessible. Use only sealings approved for gas.
- On high pressure mechanical testing of the gas piping, the boiler should not be connected (Pmax: 100 mbar).
- Always blow through gas piping before commissioning the boiler (to evacuate particles created by soldering or from threaded joints).
- After commissioning the installation, check that the pressure test points are properly closed and check the general leaktightness of the gas circuit (e.g. using a foaming agent or a U-tube manometer).
- The gas supply pipe to the boiler should never cause a pressure drop of more than 1 mbar (10 mmWG).
Example: natural gas type H G20 20 mbar for 10 metres of pipe with 4 elbows (1 elbow roughly equivalent to 0.5 metre) minimum diameter 26/28.

7 - ELECTRICAL CONNECTIONS

Protection index IP 44 (sealed model - C₃₃) - IP 24 (model B₂₃).

Power supply cable 3 x 1.5 mm² with earth.



Ensure correct polarity (230 V - 50 Hz).

7.1 - Connecting QAC31 outside sensor and QAA70 room sensor options

- Use the connectors supplied with the sensors.
- Wire up these connectors to the length required; the polarity of the wires is not significant.
- Connect the sensors to the terminal block (fig. 22).

7.2 - Additional functions

A modem function is only possible if a QAA70 is connected.

The remote control is connected to the antifreeze input (ST23) on the LGM 11.34 side and behaves as a switch either shunting the antifreeze input or leaving an open circuit across it.



Comply with protection class III.

Effects of the switch position:

- Switch closed (short-circuit): The QAA70 is set to standby in the LGM (the QAA70 regime indicated is cancelled).
- Switch open (open-circuit): No effect on the QAA70 regime.

7.3 - Wiring diagram

Fig. 22

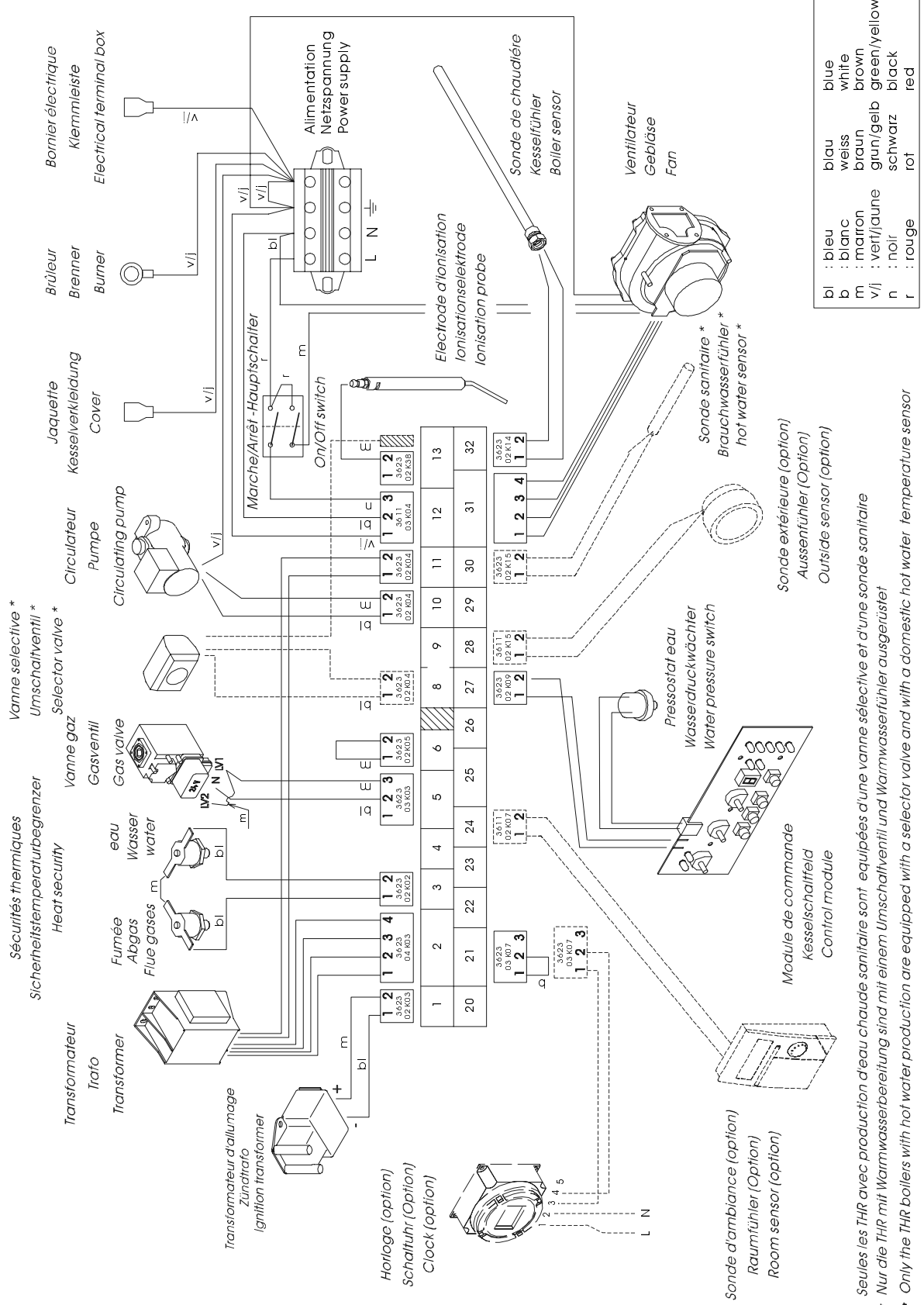

blu	: bleu	blau	: blau
bl	: blanc	weiss	: weiss
m	: marron	braun	: braun
v/j	: vert/jaune	grün/gelb	: grün/gelb
n	: noir	schwarz	: schwarz
r	: rouge	rot	: rot
		blau	: blau
		white	: weiss
		brown	: braun
		green/yellow	: grün/gelb
		black	: schwarz
		red	: rot

* Seules les THR avec production d'eau chaude sanitaire sont équipées d'une vanne sélective et d'une sonde sanitaire
 * Nur die THR mit Warmwasserbereitung sind mit einem Umschaltventil und Warmwasserfühler ausgerüstet
 * Only the THR with hot water production are equipped with a selector valve and with a domestic hot water temperature sensor

V - COMMISSIONING

Before commissioning, the installer must :

- Check that the boiler is suitable for the gas used.
- Perform a leak check on the gas system.
- Carefully bleed the air from the gas line. If the system is new, bleeding chases the air out of the lines so that the boiler has a suitable fuel. Air in the gas prevents ignition of the burner and with trip of the safety device by the flame monitor unit. This remark applies to a new system using natural gas and LPG. In the second case, the storage tank should also be efficiently bled before commissioning.



Apply all due safety precautions for venting the gas bleed.

The gas bleed also removes oxide particles resulting from brazing from the piping.

- Check the flue gas outlet for leaks and free passage of the combustion products.
- Check that the system is filled with water, $P = 1.5$ bar, radiators bled, valves open.



Do not allow the pressure to fall below 1 bar).

- Check that the electrical connection is correct: 230 V (+10 %, - 15 %), 50 Hz, polarities correct.
- Check that the condensate drain is connected.
- Check that the trap is filled with water.

When commissioning, the installer must check:

- Correct operation of the controller.
- Correct operation of the flame monitor.
- Setting of the burner for CO, CO₂ emissions.

1 - COMMISSIONING

- Open the hand-operated valve on the gas supply.
- Switch on the main heating switch.

The regulator undergoes a self-test sequence, displaying codes L, P, C, 6, and 5 in turn. The display then shows 9, and finally 0.

After a wait lasting a few seconds and if there is a demand for heating, the boiler then starts an ignition cycle. This demand depends on the boiler settings (refer to operating details for the different versions (§ 2 - III - OPERATION)).

If the boiler is currently in an alarm state, press the manual reset button. (If this alarm persists, refer to the list of fault codes).

- Burner adjustment: this is factory preset for Natural Gas type H (G20) or Propane (G31) depending on model. However, the following checks should be carried out when commissioning (the burner should be on; see burner port description and comments, fig. 11 § 5 - III - OPERATION).

2 - OPERATING PRESSURE CHECK

P_1 = Natural Gas H (G20) - 20 mbar, mains pressure; Propane (G31) 37 mbar,

P_2 = Gas pressure controlled by air pressure

PL = Servo-air pressure (Pa) (burner - gas valve)

3 - GAS /CO₂/CO/NO_x FLOW CHECK

Select the regulator off position ("7" flashing - § 3.7.3 - III - OPERATION), then check the following combustion parameters at maximum and minimum power.

Hot water potentiometer at left hand stop point = P min., at right hand stop point = P max.

Adjust the gas flow using an analyser to obtain the CO/CO₂ rates shown in the table:

Type THR					THR 10-50
Heat output	30/50 °C	B ₂₃	min./max.	kW	10,6/50,5
	30/50 °C	C ₁₃ /C ₃₃	min./max.	kW	10,6/47,8
	60/80 °C	B ₂₃	min./max.	kW	9,5/47,0
	60/80 °C	C ₁₃ /C ₃₃	min./max.	kW	9,5/44,5
Max. Heat input				kW	10,0/50,0
Ø Gas reducer	Natural gas H		mm	7,30	
	Propane		mm	5,60	
Ø Air ring	Natural gas H		mm	-	
	Propane		mm	31	
Gas flow (15 °C 1013 mbar)	Natural gas G20		m ³ /h	1,06/5,29	
	Propane G31		kg/h	0,776/3,881	
Gas Pressure P2	Natural gas H		mbar	0,40/6,00	
	Propane		mbar	0,40/6,20	
Servo-air pressure (PL)	Natural gas H		Pa	40/610	
	Propane		Pa	40/630	
CO ₂	Natural gas H		%	7,5-8,0/9,0-9,5	
	Propane		%	10,0-10,5/10,5-11,0	
CO	Natural gas H		ppm	0/20	
No _x	Natural gas H		ppm	20/25	

Combustion product evacuation conduit back-pressure: 0 mmWG.

The values of P1 and P2 may be higher or lower depending on whether the back pressure is higher or lower.

4 - CONVERSION SET

This operation should be carried out by a qualified professional equipped with a calibrated combustion analyser.

Before each intervention, switch off electrical and gas supplies.

The boiler is pre-set in work for Natural gas H (G20) or for LPG (G31).

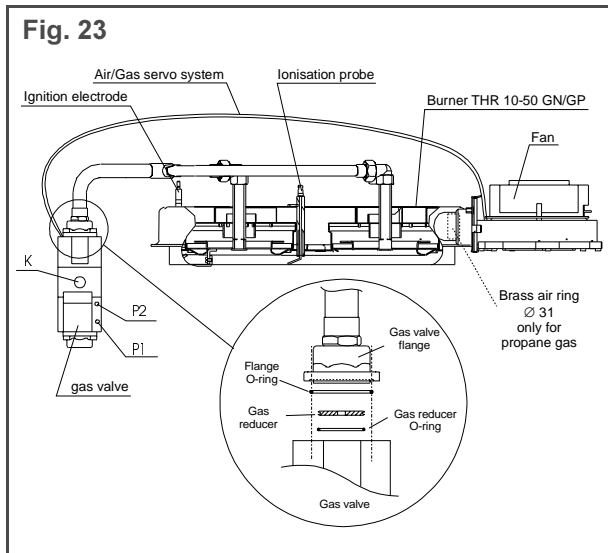

4.1 - Conversion from Natural gas H to LPG

- Replace gas reducer \varnothing 7.30 (Natural gas H) by gas reducer \varnothing 5.60 at the gas valve outlet (fig. 23).
- Insert air ring \varnothing 31 into the burner sleeve (fig. 23).
- Check combustion parameters (see table § 3 - V - COMMISSIONING).
- If necessary, proceed to the adjustment of gas valve according the process described hereafter (a CO_2/CO analyser calibrated beforehand is necessary).

4.2 - Conversion from LPG to Natural gas H

- Replace gas reducer \varnothing 5.60 by gas reducer \varnothing 7.30 (Natural gas H) at the gas valve outlet (fig. 23).
- Remove air ring \varnothing 31 from the burner sleeve (fig. 23).
- Check combustion parameters (see table § 3 - V - COMMISSIONING).
- If necessary, proceed to the adjustment of gas valve according the process described hereafter (a CO_2/CO analyser calibrated beforehand is necessary).

4.3 - Adjustment process

- Commission the burner by pushing for about 5 seconds on button A of the control board - Switch to flashing "7" on the display. Check the gas tightness with a foaming product (inlet connections of the boiler, inlet/outlet of the gas valve, outlet of the gas tube).
- Gradually set the sanitary potentiometer to the right hand stop point (burner at maximum rate).
- Check the CO_2/CO rate according to the table § 3 - V - COMMISSIONING. The flow rate at the maximum setting is not adjustable, it's given by the gas reducer.
- Set the sanitary potentiometer to the left hand stop point (burner at minimum rate).
- Check the CO_2/CO rate according to the table § 3 - V - COMMISSIONING and adjust the V screw if necessary (screwing increases the gas flow, unscrewing reduces it).

Reminder:

- Before adjusting the minimum rate (screw K), wait for a stable CO_2/CO reading on the analyser. Switch from minimum to maximum rate several times to ensure that the adjustment has been made correctly. Use an accurately calibrated analyser.

VI - MAINTENANCE

An annual maintenance inspection must be carried out.

The main items to be checked are as follows:

Fig. 24

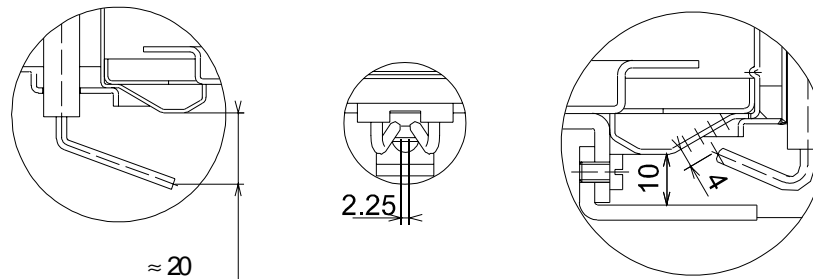

- 1) Check that the combustion gas circuit, the fan and the burner are clean and that the ignition electrodes, ionization probes and seals are in good condition.

The burner can be cleaned using a household vacuum cleaner, placing the suction tube first on the air inlet, then on the gas inlet (with the burner dismantled).

The heat exchanger can be cleaned by spraying water at it, with the burner dismantled (the water drains away via the condensate drainage siphon trap).

- 2) Combustion gas checking CO₂, CO. (see table § 3 - VI - MAINTENANCE).



The combustion products circuit is slightly pressurized.

Do not pierce the circuit without subsequently sealing off the hole made.

- 3) Check the flame monitor by disconnecting the ionization probe (safety shut-off after two attempts at ignition).
- 4) Check that the regulation is operating correctly.
- 5) Inspect the condensate drainage siphon trap.

VII - DOMESTIC HOT WATER TANKS

THR 10-50 boilers can be associated to a domestic hot water tank from the BS-range. The control panel allows the control of a 3-way selector valve and the

connection of a DHW-sensor. We can deliver, as an option, THR/BS connecting kits composed of a wiring harness, a selector valve and the connections.

Maximum quantity of hot water available in litres at 40°C (cold water at 10°C)

Tank model	BS 100		BS 150		BS 200		BS 300	
	in 10 mins	in 1 h	in 10 mins	in 1 h	in 10 mins	in 1 h	in 10 mins	in 1 h
THR 10-50	229	1067	261	1098	346	1471	476	1600

1 - ELECTRICAL CONNECTIONS

Fig. 25

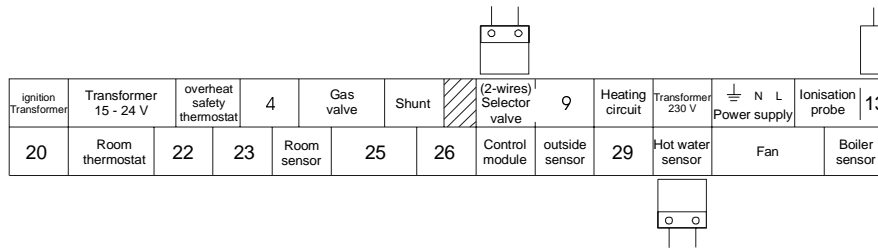

Respect the selector valve cabling:

- Lug on contact point 3 and terminal 13.
- 2-wire connection in 8.

2 - HYDRAULIC CONNECTIONS

Fig. 26

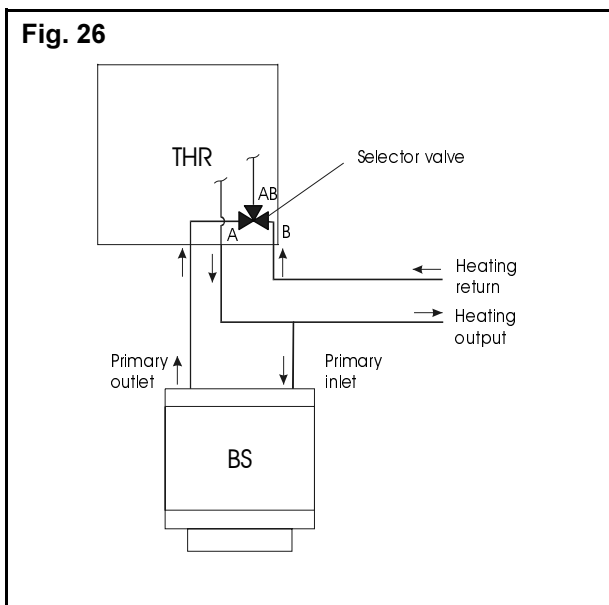

3 - OPERATING PRINCIPLE

Once the selector valve and the hot water sensor are installed, the regulator takes hot water production into account and satisfies heating and plumbing requirements.

Desired plumbing temperature adjustments are made on the boiler or the room sensor, depending on the model (See general operation § 2 - III - OPERATION).

VIII - REGLEMENTATION

1 - DECLARATION OF CONFORMITY

**Annexe II article 3.1 de la directive 90/396/CEE
Annexe IV module D de la directive 92/42/CEE**

SERIES: THR RANGE

MANUFACTURER: GEMINOX SA
16 rue des Ecoles
29410 SAINT THEGONNEC

PRODUCT CATEGORY: GAS CONDENSING WALL-HUNG BOILER RANGE ONLY HEATING OR DHW PRODUCTION

NOTIFIED BODY: 0085/DVGW
Josef-Wirmerstr. 1-3
D-53123 BONN

TYPE EXAMINATION/N°: THR 10-30/THR 10-40/THR 10-50
THR 10-50:CE0085AR0323

TEST LABORATORY: GWI
Hafenstrasse 101
45356 ESSEN

CE DIRECTIVES: 90/396CEE, 92/42CEE, 73/23CEE, 89/336CEE

BASIS OF EXAMINATION: EN 437, PREN 483, PREN 677, EN 60335.1, EN 55014, EN 55104

SURVEILLANCE PROCEDURE: Assurance for the quality of the manufacturing

DECLARATION : The a.m. products are manufactured true to the a.m. directives as well as to the approved models.
The manufacturing is examined true to the a.m. surveillance procedure.
The THR boilers comply with the requirements relating to the condensing heating boilers.

Saint-Thégonnec le : 26 Octobre 1998





NOVEMBRE 1999