

AQA C

Caldia a basamento a pellet a modulazione di combustione automatica per il riscaldamento domestico ad acqua. Collegabile ad ogni impianto di distribuzione esistente, unico cassetto per la raccolta dei residui da camera di combustione e ispezione ventola fumi (Easy Clean).

Pellet floor-standing boiler with automatic combustion modulation for domestic water heating. Connectable to any existing plumbing system, single drawer to collect ashes from combustion chamber and exhaust fan inspection (Easy Clean).

Wasserführender Pellekessel mit automatischer Verbrennungsmodulation für die Hausheizung. An jedes bereits bestehende Heizungssystem anschließbar, gemeinsame Lade für die Sammlung der Verbrennungsrückstände und der Inspektion des Abgasventilators (Easy Clean).

Chaudière au sol pellet à modulation de combustion automatique pour le réchauffement domestique hydro. Connectable à toute installation déjà existante, revêtement en acier. Un seul tiroir pour la recolte des residus de la chambre de combustion et de l'inspection de l'extracteur des fumées (Easy Clean).



Bianco
White

Modello	Potenza Plus	
AQA C	15 kW	<ul style="list-style-type: none"> Scambiatore di calore in acciaio AISI 304 Pulitore del fascio tubiero brevettato Cassetto cenere Easy Clean Accensione e spegnimento programmabili
	18 kW	<ul style="list-style-type: none"> Patentierter Wärmetauscher aus Stahl AISI 304 Patentiertes vereinfachtes Reinigungssystem Aschenlade Easy Clean Programmierbare Ein- und Ausschaltungen
	24 kW	<ul style="list-style-type: none"> Heat exchanger in stainless steel AISI 304 Patented exchanger cleaning system Ash drawer Easy Clean Programmable on and off
	30 kW	<ul style="list-style-type: none"> Échangeur de chaleur en inox AISI 304 Système de nettoyage d'échangeur breveté Tiroir à cendre Easy Clean Démarrage et arrêt programmable

**AQA C**

		15	18	24	30
Potenza termochimica Heat input	Max kW	14,9	18,0	22,9	
	Min kW	4,5	4,7	5,2	
Potenza nominale Nominal heat	Max kW	13,7	16,4	20,6	
	Min kW	4,3	4,4	4,9	
Rendimento all'acqua Water efficiency	Max %	87,8	86,7	85,1	
	Min %	84,7	84,4	84,1	
Rendimento di combustione Efficiency	Max %	91,9	91,1	90,0	
	Min %	94,8	94,5	94,1	
Potenza all'acqua Water heat output	Max kW	13,1	15,5	19,5	
	Min kW	3,8	4,0	4,4	
Consumo orario pellet Hourly pellet consumption	Max kg	3,2	3,9	4,9	
	Min kg	1,0	1,0	1,1	
Capacità serbatoio Hopper capacity	kg	75	75	75	
Superficie riscaldabile Heating area	m ²	90,0	120,0	160,0	
Uscita scarico fumi pellet Flue pipe	Ø mm	80,0	80,0	80,0	
Tiraggio Draft	Max Pa	12,0	12,0	12,0	
	Min Pa	11,0	11,0	11,0	
Entrata aria comburente pellet Pellet primary air inlet	Ø mm	50,0	50,0	60,0	
Prevalenza circolatore Water circulator prevalence	m	5,0	6,0	6,0	
Pressione di utilizzo a freddo Pressure on cold working mode	bar	0,8/1,2	0,8/1,2	0,8/1,2	
Dimensione vaso di espansione Expansion vessel	l	6,0	6,0	6,0	
Tensione di alimentazione Power supply		220 V 50 Hz	220 V 50 Hz	220 V 50 Hz	
Assorbimento elettrico in fase di lavoro Electric absorbment in working mode	W	150,0	150,0	150,0	

PROSSIMAMENTE DISPONIBILE

AQA C

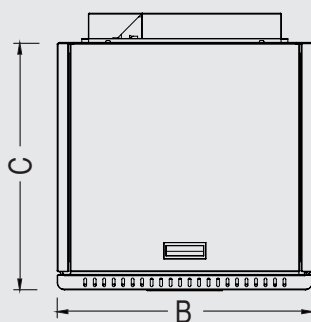

	A	B	C
15 kW	1500	560	610
18 kW	1500	560	610
24 kW	1500	560	610

