



Caldaiastufa idro a pellet a modulazione di combustione automatica per il riscaldamento domestico combinato aria-acqua.

Pellet water stove with automatic modulation of combustion for the domestic heating combined air-water.

Collegabile ad ogni impianto di distribuzione esistente - Rivestimento in alluminio disponibile in 5 colori - Porta rivestita in cristallo - Ventilazione ambiente inclusa - Scambiatore di calore in rame brevettato "L'utilizzo di fasci tubieri in rame costituisce, il principale elemento di pregio rispetto ai prodotti similari offerti dalle aziende competitor (.....) le vantaggiose proprietà di cui gode, quali la resistenza alla corrosione e le ottime caratteristiche di conducibilità termica." **Dalla Ricerca condotta presso il Dipartimento di Meccanica dell'Università della Calabria.** - Sistema di pulizia facilitato brevettato - Doppio cassetto cenere - Accensione e spegnimento programmabili - Pulitore meccanico del bracieri (PM) (optional) - Produzione acqua calda sanitaria in continuo (optional).

Connectable to any existing water heating system - External facing of aluminium available in 5 colours - Door external facing of crystal - Ambience ventilation included - Patented water heat exchanger of copper - Patented simplify exchanger cleaning system - Double ash drawer - Programmable turning on and off - Automatic mechanical cleaning of the fire pot (PM) (optional) - Production of continuous hot drinking water (optional).

An jede bereits bestehende Verteileranlage anzuschließen - Aluminiumverkleidung in 5 verschiedenen Farben - Tür mit Kristallglas verkleidet - Raumbelüftung inbegriffen - Patentierter Wärmetauscher aus Kupfer - Patentiertes Reinigungssystem - Doppellade für die Asche - Programmierbares Ein und Ausschalten - Mechanische Reinigungsvorrichtung für die Aschenlade (PM) (optional) - Kontinuierliche Warmwasserproduktion (optional).

Il se connecte à n'importe quel système de distribution existant - Revêtement en aluminium disponible en 4 couleurs - Porte avec façade en verre - Ventilateur ambience inclus - Echangeur de chaleur en cuivre breveté - Système nettoyage facilité breveté - Double tiroir à cendre - Démarrages et arrêts programmables - Nettoyage automatique mécanique du bracier (PM) (optionnel) - Production d'eau chaude en continu (optionnel).

Posible conexión a cualquier instalación de distribución existente - Revestimiento de aluminio disponible en 5 colores - Puerta revestida de cristal - Sistema de ventilación incluido - Intercambiador de calor de cobre patentado - Sistema de fácil limpieza patentado - Doble cajón recoge cenizas - Programación del encendido y apagado disponible - Sistema mecánico para la limpieza del brasero (PM) (opcional) - Producción continua de agua caliente sanitaria (opcional).



Avorio
Ivory

Nero
Black

Bordeaux
Bordeaux

Ciliegio
Cherry

Noce
Walnut



Maia Style

34 kW

Potenza termica Heat Input	Max	kW	34,7
	Min	kW	9,2
Potenza nominale Nominal heat	Max	kW	32,8
	Min	kW	9,2
Rendimento Efficiency	Max	%	94,5
	Min	%	96,9
Potenza all'acqua Water heat output	Max	kW	25,6
	Min	kW	7,4
Potenza all'aria Space heat output	Max	kW	7,3
	Min	kW	1,5
Capacità serbatoio Tank capacity		kg	35
Consumo orario pellet Hourly pellet consumption	Max	kg	6,9
	Min	kg	1,8
Autonomia di lavoro Working autonomy	Max	h	19
	Min	h	5
Superficie riscaldabile Heatable surface		m ²	270
Uscita scarico fumi pellet Pellet smoke outlet		Ø mm	80,0
Tiraggio Max Draft	Max	Pa	12,0
	Min	Pa	11,0
Entrata aria comburente pellet Pellet primary air inlet		Ø mm	60,0
Prevalenza circolatore Water circulator prevalence		m	6,0
Pressione di utilizzo a freddo Pressure on cold working mode		bar	0,8/1,2
Dimensione vaso di espansione Expansion vase size		l	8,0
Produzione acqua calda sanitaria (optional) Hot drinking water production (option)		lt/min	12,0
Tensione di alimentazione Working voltage supply			220 V - 50 Hz
Absorbimento elettrico in fase di lavoro Electric absorbment in working mode		Watt	175,0
Peso Weight		kg	220,0

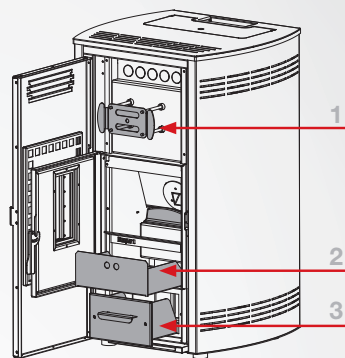

- 1 Sistema pulizia facilitato BREVETTATO
Patented simplify exchanger cleaning system
- 2 Cassetto cenere principale
Main ash drawer
- 3 Cassetto cenere secondario
Lower ash drawer

