



Service Manual

DELTA 18-21-24

Indoor Units	Outdoor Units
<i>DELTA 18</i>	<i>GC 18</i>
<i>DELTA 21</i>	<i>GC 22</i>
<i>DELTA 24</i>	<i>OU7-24</i>
	<i>OU7-24Z</i>



REFRIGERANT

COOLING ONLY

R410A

HEAT PUMP

SM DELTA 1-E.0 GB

JUNE – 2010

LIST OF EFFECTIVE PAGES

Note: Changes in the pages are indicated by a “Revision#” in the footer of each effected page (when none indicates no changes in the relevant page). All pages in the following list represent effected/ non effected pages divided by chapters.

Dates of issue for original and changed pages are:

Original 0 JUNE 2010

Total number of pages in this publication is 93 consisting of the following:

Page No.	Revision No. #		Page No.	Revision No. #		Page No.	Revision No. #
----------	----------------	--	----------	----------------	--	----------	----------------

Title 0
 A 0
 i 0
 1-1 - 1-3 0
 2-1 - 2-5 0
 3-1 0
 4-1 - 4-2 0
 5-1 - 5-12 0
 6-1 - 6-5 0
 7-1 0
 8-1 - 8-6 0
 9-1 0
 10-1-10-4 0
 11-1 0
 12-1-12-34 0
 13-1-13-2 0
 14-1-14-24 0
 15-1-15-7 0
 Appendix -A 0

• Zero in this column indicates an original page.

*Due to constant improvements please note that the data on this service manual can be modified with out notice.

**Photos are not contractual

Table of Contents

1. INTRODUCTION	1-1
2. PRODUCT DATA SHEET	2-1
3. RATING CONDITIONS	3-1
4. OUTLINE DIMENSIONS	4-1
5. PERFORMANCE DATA & PRESSURE CURVES	5-1
6. SOUND LEVEL CHARACTERISTICS	6-1
7. ELECTRICAL DATA.....	7-1
8. WIRING DIAGRAMS.....	8-1
9. ELECTRICAL CONNECTIONS.....	9-1
10. REFRIGERATION DIAGRAMS.....	10-1
11. TUBING CONNECTIONS.....	11-1
12. CONTROL SYSTEM	12-1
13. TROUBLESHOOTING	13-1
14. EXPLODED VIEWS AND SPARE PARTS LISTS.....	14-1
15. OPTIONAL ACCESSORIES	15-1
16. APPENDIX A	16-1

1. INTRODUCTION

1.1 General

The new **DELTA** split wall mounted is based on the compact range. It comprise the ST (cooling only) and RC (heat pump) models, as follows:

- **Cooling Only:** *DELTA 18ST, DELTA 21ST, DELTA 24ST*
- **Heat Pump:** *DELTA 18RC, DELTA 21RC, DELTA 24RC*

The indoor **DELTA** units are available as LED display types, featuring esthetic design, compact dimensions, and low noise operation.

1.2 Main Features

The **DELTA** series benefits from the most advanced technological innovations, namely:

- R410A refrigerant
- Micro processor control.
- Infrared remote control with LED display.
- Indoor large diameter cross flow fan, allowing low operation sound level.
- Bended Indoor coil with treated aluminum fins and coating for improved efficiency.
- High COP.
- Easy access to the interconnecting tubing and wiring connections.
- Refrigerant pipes can be connected to the indoor unit from 5 different optional directions.
- The units are equipped.
- Water condensate tray is equipped with two optional drain connections.
- Automatic treated air sweep.
- Low indoor noise levels.
- Easy installation and service.

1.3 Indoor Unit

The indoor unit is wall mounted, and can be easily fitted to many types of residential and commercials applications.

It includes:

- Casing with air inlet and outlet grills.
- A large-diameter tangential fan.
- Bended coil with treated aluminum fins.
- Motorized flaps.
- 3-speed motor with internal protection.
- Advanced electronic control box assembly.
- Interconnecting wiring terminal block.
- Mounting plate.

1.4 Filtration

The **DELTA** series presents several types of air filters:

- Easily accessible, and re-usable pre-filters (mesh).
- Pre-charged electrostatic filter (diposable).
- Active carbon filter (optional).
- Active Electro Static re-usable filter (optional).

1.5 Control

The microprocessor indoor controller, and an infrared remote control, supplied as standard, provide complete operating function and programming. For further details please refer to the Operation Manual, Appendix A.

1.6 Outdoor Unit

The **DELTA** outdoor units can be installed as floor or wall mounted units by using a wall supporting bracket. The metal sheets are protected by anti-corrosion paint work allowing long life resistance. All outdoor units are pre-charged. For further information please refer to the Product Data Sheet, Chapter 2.

It includes :

- Axial fan.
- Outdoor coil with hydrophilic louver fins for RC units.
- Compressor mounted in a soundproofed compartment.
- Outlet air fan grill.
- Service valves" flare" type connection.
- Interconnecting wiring terminal block.

1.7 Tubing Connections

Flare type interconnecting tubing can be produced on site.
For further details please refer to the Installation Manual, Chapter 11.

1.8 Accessories

ASK (All Season Kit):

For low ambient working conditions in cooling, an ASK can be installed inside the outdoor unit. This kit allows cooling operation down to outdoor temp of -10 oC by gradually controlling the outdoor fan speed motor.

RCW Wall Mounted Remote Control

The RCW remote control is mounted on the wall, and controls the unit either as an infrared remote control or as a wired controller. The wired controller can control up to 10 Indoor units with the same program settings and adjustments.
For further details please refer to Optional Accessories, Chapter 15.

1.9 Inbox Documentation

Each unit is supplied with its own installation and operation manuals.

1.10 Matching Table

1.10.1 R410A

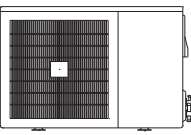
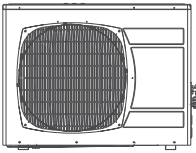
OUTDOOR UNITS		INDOOR UNITS			
					
MODEL	REFRIGER.	DELTA 18	DELTA 21	DELTA 24	
	GC 18 ST/RC	R410A	✓		
	GC 22 ST/RC	R410A		✓	
	GC 24 ST/RC	R410A			✓
	OU7-24	R410A		✓	
	OU7-24Z	R410A		✓	

The above table lists outdoor units and DELTA indoor units which can be matched together. In addition the listed outdoor units can be matched with other types of indoor units such as cassettes, floor/ceiling. For further information please refer to the relevant Service Manual.

2. PRODUCT DATA SHEET

2.1 DELTA 18 / GC 18 R410A

Model Indoor Unit		DELTA- 18		
Model Outdoor Unit		GC-18		
Installation Method of Pipe		Flared		
Characteristics	Units	Cooling Only	Cooling	Heating
Capacity ⁽⁴⁾	Btu/hr	18250	18250	18420
	kW	5.35	5.35	5.40
Power input ⁽⁴⁾	kW	1.66	1.66	1.56
EER (Cooling) or COP(Heating) ⁽⁴⁾	W/W	3.22	3.22	3.46
Energy efficiency class		A	A	B
Power supply	V/Hz/Ph	220-240V/50Hz/Single		
Rated current	A	7.5	7	7.1
Starting current	A	43		
Circuit breaker rating	A	15		
INDOOR	Fan type & quantity		Cross flow*1	
	Fan speeds	H/M/L	RPM	1200/1100/1000
	Air flow ⁽¹⁾	H/M/L	m ³ /hr	930/840/750
	External static pressure	Min-Max	Pa	N/A
	Sound power level ⁽²⁾	H/M/L	dB(A)	56/53/50
	Sound pressure level ⁽³⁾	H/M/L	dB(A)	43/40/37
	Moisture removal		l/hr	1.8
	Condensate drain tube I.D		mm	16
	Dimensions	WxHxD	mm	1060/295/210
	Weight		kg	14
	Package dimensions	WxHxD	mm	1115/350/260
	Packaged weight		kg	17
	Units per pallet		units	16
	Stacking height		units	8
OUTDOOR	Refrigerant control		Capillary tube	
	Compressor type,model		Rotary,TOSHIBA PA200X2CS-4KU1	
	Fan type & quantity		Propeller(direct) x 1	
	Fan speeds	H/L	RPM	815
	Air flow	H/L	m ³ /hr	2480
	Sound power level	H/L	dB(A)	68
	Sound pressure level ⁽³⁾	H/L	dB(A)	57
	Dimensions	WxHxD	mm	846/302/690
	Weight		kg	56
	Package dimensions	WxHxD	mm	990/430/770
	Packaged weight		kg	61
	Units per pallet		Units	9
	Stacking height		units	3
	Refrigerant type		R410A	
	Refrigerant chargless distance		kg/m	1.54kg/7.5m
	Additional charge		g/m	4m≤Length≤10m 1540g 10m≤Length≤18m 1690g 18m≤Length≤25m 1900g
	Connections between units	Liquid line	In.(mm)	1/4"(6.35)
Suction line		In.(mm)	1/2"(12.7)	
Max.tubing length		m.	25	
Max.height difference		m.	15	
Operation control type		Remote control		
Heating elements		kW		
Others		All season kit Factory option		

(1) Rating conditions in accordance with ISO 5151 and ISO 13253 (for ducted units). and EN 14511

(2) Airflow in ducted units; at nominal external static pressure.

(3) Sound power in ducted units is measured at air discharge.

(4) Sound pressure level measured at 1 meter distance from unit.

2.2 DELTA 21 / GC 22 R410A

Model Indoor Unit			DELTA- 21		
Model Outdoor Unit			GC-22		
Installation Method of Pipe			Flared		
Characteristics		Units	Cooling Only	Cooling	Heating
Capacity ⁽⁴⁾		Btu/hr	21150	21150	22180
		kW	6.2	6.2	6.50
Power input ⁽⁴⁾		kW	2.05	2.05	2.00
EER (Cooling) or COP(Heating) ⁽⁴⁾		W/W	3.02	3.02	3.25
Energy efficiency class			B	B	C
Power supply		V/Hz/Ph	220-240V/50Hz/Single		
Rated current		A	9.3	9.3	9.7
Starting current		A	50		
Circuit breaker rating		A	20		
INDOOR	Fan type & quantity			Cross flow*1	
	Fan speeds	H/M/L	RPM	1300/1200/1100	
	Air flow ⁽¹⁾	H/M/L	m ³ /hr	910/820/740	
	External static pressure	Min-Max	Pa	0	
	Sound power level ⁽²⁾	H/M/L	dB(A)	60/57/55	
	Sound pressure level ⁽³⁾	H/M/L	dB(A)	47/44/42	
	Moisture removal		l/hr	2.3	
	Condensate drain tube I.D		mm	16	
	Dimensions	WxHxD	mm	1060x295x210	
	Weight		kg	15	
	Package dimensions	WxHxD	mm	1125x360x280	
	Packaged weight		kg	18	
	Units per pallet		units	16	
	Stacking height		units	8	
OUTDOOR	Refrigerant control			Capillary tube	
	Compressor type,model			Rotary,TOSHIBA PA240X2CS-4KU1	
	Fan type & quantity			Propeller(direct) x 1	
	Fan speeds	H/L	RPM	815	
	Air flow	H/L	m ³ /hr	2860	
	Sound power level	H/L	dB(A)	69	
	Sound pressure level ⁽³⁾	H/L	dB(A)	59	
	Dimensions	WxHxD	mm	846/302/690	
	Weight		kg	56	
	Package dimensions	WxHxD	mm	990/720/430	
	Packaged weight		kg	61	
	Units per pallet		Units	9	
	Stacking height		units	3 levels	
	Refrigerant type			R410A	
	Refrigerant chargless distance		kg/m	2.0kg/7.5m	
	Additional charge		g/m	4m≤Length≤10m:+0g; 10m≤Length≤15m:+330g; 15m≤Length≤20m:+460g	
Connections between units	Liquid line	In.(mm)	3/8"(9.53)		
	Suction line	In.(mm)	5/8"(15.88)		
	Max.tubing length	m.	Max 20		
	Max.height difference	m.	Max 15		
Operation control type			Remote control		
Heating elements		kW	1.65/0.9		
Others					

⁽¹⁾Rating conditions in accordance with ISO 5151 and ISO 13253 (for ducted units), and EN 14511

⁽²⁾Airflow in ducted units; at nominal external static pressure.

⁽³⁾Sound power in ducted units is measured at air discharge.

⁽⁴⁾Sound pressure level measured at 1 meter distance from unit.

2.3 DELTA 24 / OU7-24 R410A

Model Indoor Unit			DELTA- 24		
Model Outdoor Unit			OU7-24		
Installation Method of Pipe			Flared		
Characteristics	Units		Cooling Only	Cooling	Heating
Capacity ⁽⁴⁾	Btu/hr		23100	23100	24150
	kW		6.77	6.77	7.08
Power input ⁽⁴⁾	kW		2.24	2.24	2.35
EER (Cooling) or COP(Heating) ⁽⁴⁾	W/W		3.02	3.02	2.95
Energy efficiency class			B	B	D
Power supply	V/Hz/Ph		220-240V/50Hz/Single		
Rated current	A		10.5	10.5	11.0
Starting current	A		63		
Circuit breaker rating	A		20		
INDOOR	Fan type & quantity			Cross flow*1	
	Fan speeds	H/M/L	RPM	1300/1200/1100	
	Air flow ⁽¹⁾	H/M/L	m3/hr	910/820/740	
	External static pressure	Min-Max	Pa	N/A	
	Sound power level ⁽²⁾	H/M/L	dB(A)	60/57/55	
	Sound pressure level ⁽³⁾	H/M/L	dB(A)	47/44/42	
	Moisture removal		l/hr	2.3	
	Condensate drain tube I.D		mm	16	
	Dimensions	WxHxD	mm	1060x295x210	
	Weight		kg	15	
	Package dimensions	WxHxD	mm	1125x360x280	
	Packaged weight		kg	18	
	Units per pallet		units	16	
	Stacking height		units	8	
	OUTDOOR	Refrigerant control			Capillary tube
Compressor type,model			Rotary		
Fan type & quantity			AXIAL*1		
Fan speeds		H/L	RPM	850	720
Air flow		H/L	m3/hr	3100	2600
Sound power level		H/L	dB(A)	67	62
Sound pressure level ⁽³⁾		H/L	dB(A)	58	54
Dimensions		WxHxD	mm	900/680/340	
Weight			kg	74	
Package dimensions		WxHxD	mm	985/730/406	
Packaged weight			kg	77	
Units per pallet			Units	6	
Stacking height			units	2 levels	
Refrigerant type			R410A		
Refrigerant chargless distance		kg/m	2.035kg/12.5m		
Additional charge		g/m	12.5m<Add 350g<15m; 15m<Add 1040g<20m;		
Connections between units		Liquid line	In.(mm)	3/8"(9.53)	
	Suction line	In.(mm)	5/8"(15.88)		
	Max.tubing length	m.	Max 20		
	Max.height difference	m.	Max 15		
Operation control type			Remote control		
Heating elements		kW			
Others			All season kit Factory option		

⁽¹⁾Rating conditions in accordance with ISO 5151 and ISO 13253 (for ducted units), and EN 14511

⁽²⁾Airflow in ducted units; at nominal external static pressure.

⁽³⁾Sound power in ducted units is measured at air discharge.

⁽⁴⁾Sound pressure level measured at 1 meter distance from unit.

2.4 DELTA 24 / OU7-24Z R410A

Model Indoor Unit			DELTA- 24		
Model Outdoor Unit			OU7-24Z		
Installation Method of Pipe			Flared		
Characteristics		Units	Cooling Only	Cooling	Heating
Capacity ⁽⁴⁾		Btu/hr	23100	23100	24150
		kW	6.77	6.77	7.08
Power input ⁽⁴⁾		kW	2.24	2.24	2.35
EER (Cooling) or COP(Heating) ⁽⁴⁾		W/W	3.02	3.02	2.95
Energy efficiency class			B	B	D
Power supply		V/Hz/Ph	220-240V/50Hz/Single		
Rated current		A	10.5	10.5	11.0
Starting current		A	63		
Circuit breaker rating		A	20		
INDOOR	Fan type & quantity			Cross flow*1	
	Fan speeds	H/M/L	RPM	1300/1200/1100	
	Air flow ⁽¹⁾	H/M/L	m3/hr	910/820/740	
	External static pressure	Min-Max	Pa	N/A	
	Sound power level ⁽²⁾	H/M/L	dB(A)	60/57/55	
	Sound pressure level ⁽³⁾	H/M/L	dB(A)	47/44/42	
	Moisture removal		l/hr	2.3	
	Condensate drain tube I.D		mm	16	
	Dimensions	WxHxD	mm	1060x295x210	
	Weight		kg	15	
	Package dimensions	WxHxD	mm	1125x360x280	
	Packaged weight		kg	18	
	Units per pallet		units	16	
	Stacking height		units	8	
	OUTDOOR	Refrigerant control			Capillary tube
Compressor type,model			Rotary		
Fan type & quantity			AXIAL*1		
Fan speeds		H/L	RPM	850	720
Air flow		H/L	m3/hr	3100	2600
Sound power level		H/L	dB(A)	67	62
Sound pressure level ⁽³⁾		H/L	dB(A)	58	54
Dimensions		WxHxD	mm	900/680/340	
Weight			kg	64	
Package dimensions		WxHxD	mm	985/730/406	
Packaged weight			kg	67	
Units per pallet			Units	6	
Stacking height			units	2 levels	
Refrigerant type				R410A	
Refrigerant chargeless distance			kg/m	1.7kg / 7.5m	
Additional charge			g/m	7.5m<Add 30g / <15m;	
Connections between units		Liquid line	In.(mm)	3/8"(9.53)	
	Suction line	In.(mm)	5/8"(15.88)		
	Max.tubing length	m.	Max 15		
	Max.height difference	m.	Max 7		
Operation control type			LCD Remote control		
Heating elements		kW			
Others					

⁽¹⁾Rating conditions in accordance with ISO 5151 and ISO 13253 (for ducted units), and EN 14511

⁽²⁾Airflow in ducted units; at nominal external static pressure.

⁽³⁾Sound power in ducted units is measured at air discharge.

⁽⁴⁾Sound pressure level measured at 1 meter distance from unit.

2.4 DELTA 24 / OU7-24T R410A

Model Indoor Unit		DELTA- 24			
Model Outdoor Unit		OU7-24T			
Installation Method of Pipe		Flared			
Characteristics		Units	Cooling Only	Cooling	Heating
Capacity ⁽⁴⁾		Btu/hr	23220	23220	25130
		kW	6.81	6.81	7.37
Power input ⁽⁴⁾		kW	2.26	2.26	2.4
EER (Cooling) or COP(Heating) ⁽⁴⁾		W/W	3.02	3.02	3.07
Energy efficiency class			B	B	D
Power supply		V/Hz/Ph	400V/50Hz/3N		
Rated current		A	4.1×3	4.1×3	4.4×3
Starting current		A	55		
Circuit breaker rating		A	10×3		
INDOOR	Fan type & quantity			Cross flow*1	
	Fan speeds	H/M/L	RPM	1300/1200/1100	
	Air flow ⁽¹⁾	H/M/L	m3/hr	990/930/840	
	External static pressure	Min-Max	Pa	N/A	
	Sound power level ⁽²⁾	H/M/L	dB(A)	58/55/53	
	Sound pressure level ⁽³⁾	H/M/L	dB(A)	45/42/40	
	Moisture removal		l/hr	2.3	
	Condensate drain tube I.D		mm	16	
	Dimensions	WxHxD	mm	1060/295/210	
	Weight		kg	15	
	Package dimensions	WxHxD	mm	1115/350/260	
	Packaged weight		kg	18	
	Units per pallet		units	16	
	Stacking height		units	8	
	OUTDOOR	Refrigerant control			Capillary tube
Compressor type,model			Rotary		
Fan type & quantity			AXIAL*1		
Fan speeds		H/L	RPM	850	720
Air flow		H/L	m3/hr	3100	2600
Sound power level		H/L	dB(A)	67	62
Sound pressure level ⁽³⁾		H/L	dB(A)	58	54
Dimensions		WxHxD	mm	900/680/340	
Weight			kg	74	
Package dimensions		WxHxD	mm	985/730/406	
Packaged weight			kg	74	
Units per pallet			Units	6	
Stacking height			units	2 levels	
Refrigerant type				R410A	
Refrigerant chargeless distance			kg/m	2.035kg / 12.5m	
Additional charge		g/m	12.5m<Add 350g <15m; 12.5m<Add 1040g<20m		
Connections between units	Liquid line	In.(mm)	3/8"(9.53)		
	Suction line	In.(mm)	5/8"(15.88)		
	Max.tubing length	m.	Max 20		
	Max.height difference	m.	Max 15		
Operation control type			LCD Remote control		
Heating elements		kW			
Others			All season kit Factory option		

⁽¹⁾Rating conditions in accordance with ISO 5151 and ISO 13253 (for ducted units), and EN 14511

⁽²⁾Airflow in ducted units; at nominal external static pressure.

⁽³⁾Sound power in ducted units is measured at air discharge.

⁽⁴⁾Sound pressure level measured at 1 meter distance from unit.

3. RATING CONDITIONS

Standard conditions in accordance with ISO 5151, ISO 13253 (for ducted units) and EN 14511.

Cooling:

Indoor: 27°C DB 19°C WB

Outdoor: 35°C DB

Heating:

Indoor: 20°C DB

Outdoor: 7°C DB 6°C WB

3.1 Operating Limits

3.1.1 R410A

		Indoor	Outdoor
Cooling	Upper limit	32°C DB 23°C WB	46°C DB
	Lower limit	21°C DB 15°C WB	21°C DB
Heating	Upper limit	27°C DB	24°C DB 18°C WB
	Lower limit	20°C DB	-9°C DB -10°C WB
Voltage	1PH	198 – 264 V	
	3PH	360 – 440 V	

4. OUTLINE DIMENSIONS

4.1 Indoor Unit: DELTA 18, 21, 24

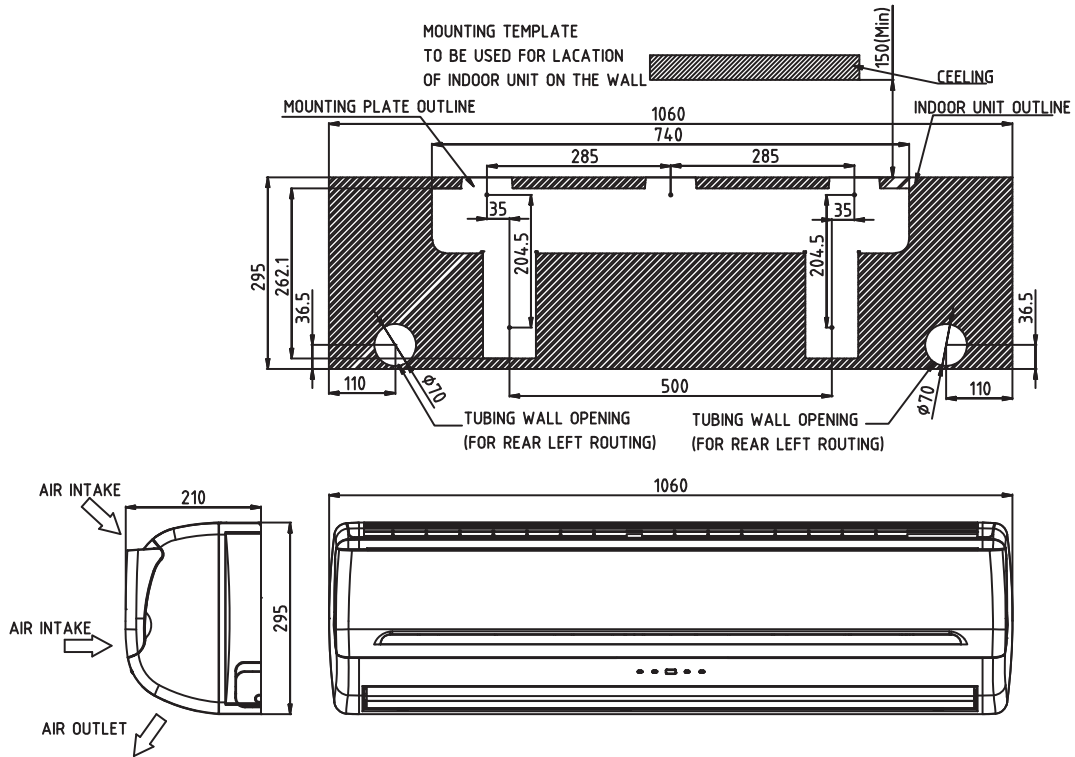

4.2 Outdoor Unit: GC 18, 22

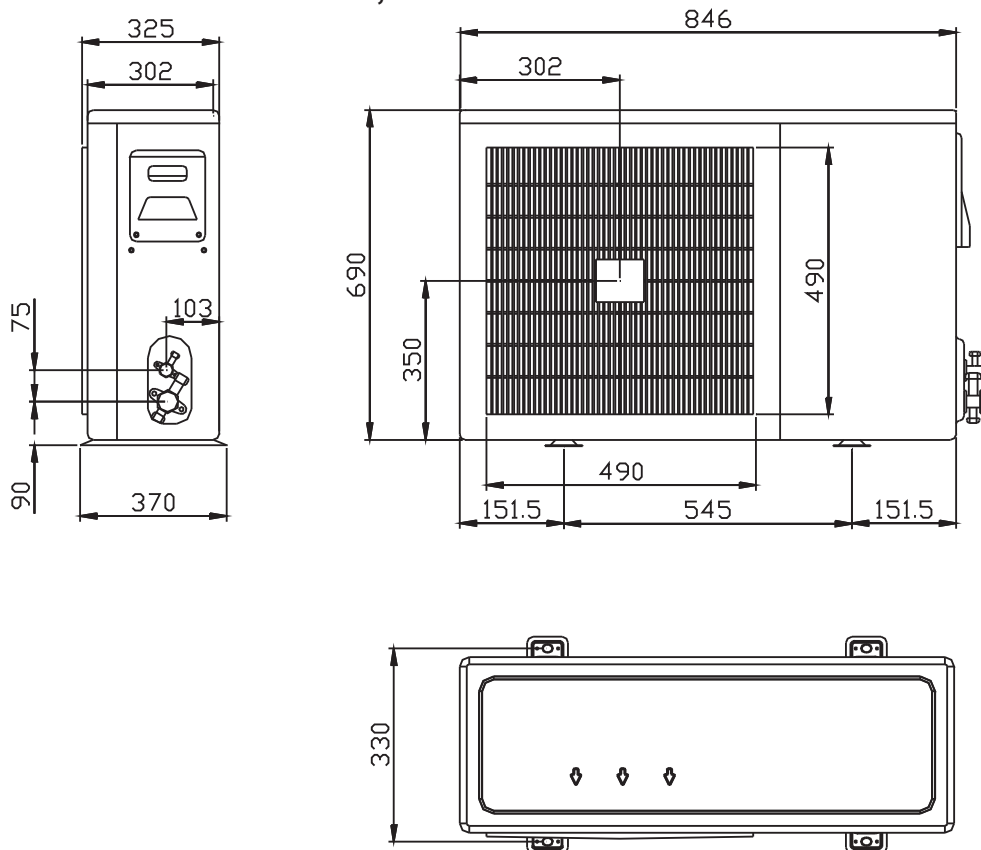

4.3 Outdoor Unit: OU7-24, OU7-24Z

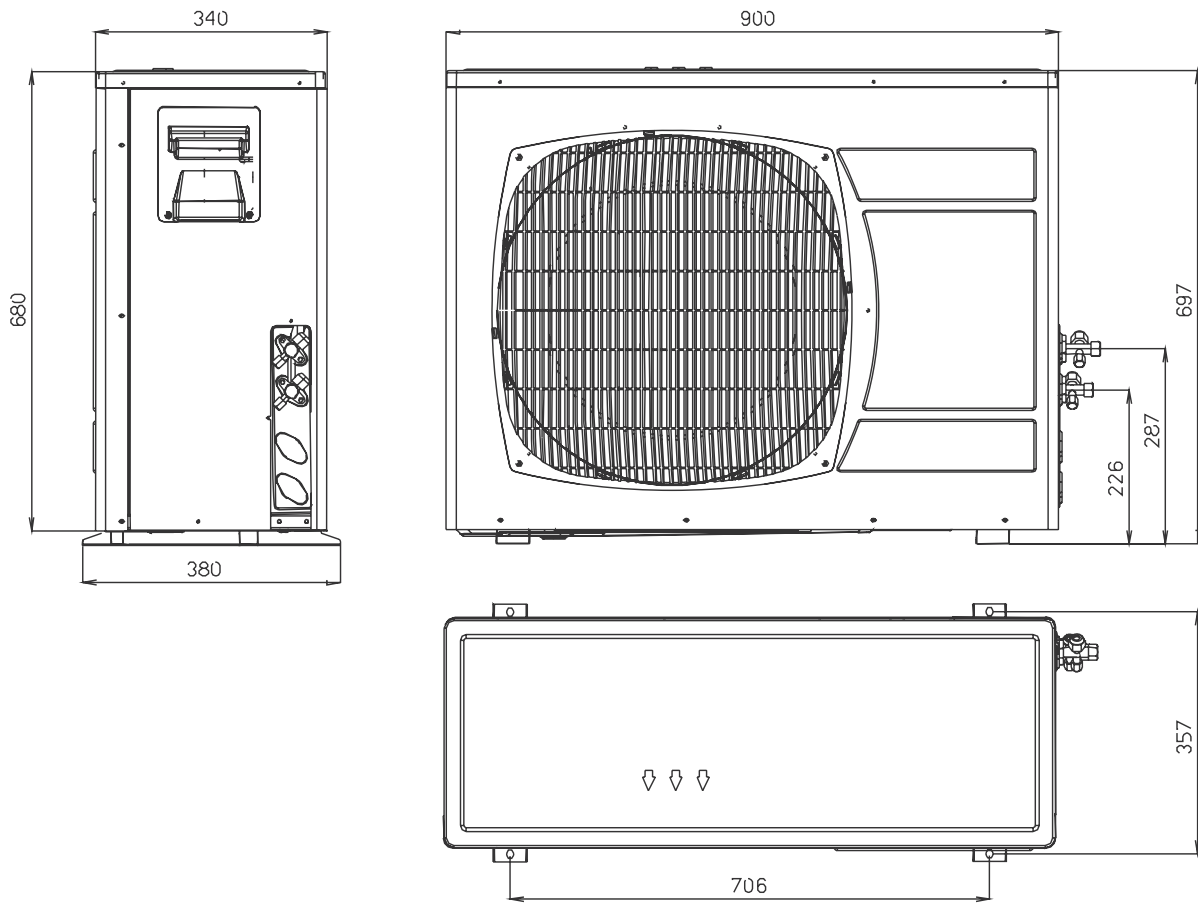

5. PERFORMANCE DATA & PRESSURE CURVES

5.1 DELTA18 GC18 R410A

5.1.1 Cooling Mode at 7.5m Tubing Connection.

230V : Indoor Fan at High Speed.

ENTERING AIR DB OU COIL (°C)	DATA	ENTERING AIR WB/DB ID COIL (°C)				
		15/21	17/24	19/27	21/29	23/32
15 ⁽¹⁾	TC	5.64	5.84	5.98	6.12	6.21
	SC	3.87	4.03	4.19	4.30	4.38
	PI	1.18	1.18	1.18	1.18	1.19
20 ⁽¹⁾	TC	5.46	5.75	5.93	6.07	6.20
	SC	3.79	4.00	4.17	4.28	4.36
	PI	1.28	1.28	1.29	1.29	1.30
25	TC	5.16	5.57	5.86	6.04	6.18
	SC	3.69	3.92	4.13	4.25	4.33
	PI	1.38	1.39	1.40	1.41	1.42
30	TC	4.83	5.26	5.68	5.88	6.05
	SC	3.58	3.80	4.04	4.16	4.24
	PI	1.49	1.51	1.52	1.54	1.55
35	TC	4.47	4.85	5.35	5.62	5.88
	SC	3.40	3.65	3.95	4.06	4.14
	PI	1.61	1.63	1.66	1.67	1.68
40	TC	4.06	4.42	4.83	5.28	5.55
	SC	3.21	3.45	3.74	3.86	3.93
	PI	1.73	1.76	1.79	1.81	1.83
46	TC	3.53	3.86	4.24	4.68	5.05
	SC	2.95	3.16	3.41	3.53	3.60
	PI	1.89	1.92	1.97	1.99	2.02

LEGEND

- TC – Total Cooling Capacity, kW
- SC – Sensible Capacity, kW
- PI – Power Input, kW
- WB – Wet Bulb Temp., (°C)
- DB – Dry Bulb Temp., (°C)
- ID – Indoor
- OU – Outdoor

(1) Marked area is below standard operating limits. For operating in low ambient conditions, refer to Optional Accessories (Chapter 15).

5.1.2 Heating Mode at 7.5m Tubing Connection.

230V : Indoor Fan at High Speed.

ENTERING AIR WB OU COIL (°C)	ENTERING AIR DB ID COIL (°C)					
	15		20		25	
	TH	PI	TH	PI	TH	PI
-10	2.84	1.25	2.73	1.33	2.62	1.40
-7	3.05	1.28	2.94	1.35	2.84	1.42
-2	3.24	1.29	3.13	1.37	3.02	1.45
2	3.94	1.36	3.78	1.44	3.62	1.53
6	5.56	1.46	5.40	1.56	5.21	1.66
10	6.05	1.54	5.89	1.65	5.72	1.76
15	6.53	1.61	6.37	1.73	6.21	1.84
20	6.89	1.65	6.72	1.79	6.53	1.93

* the above chart includes the weighted deicing influence.

LEGEND

- TH – Total Heating Capacity, kW
- PI – Power Input, kW
- WB – Wet Bulb Temp., (°C)
- DB – Dry Bulb Temp., (°C)
- ID – Indoor
- OU – Outdoor

5.2 Capacity Correction Factor Due to Tubing Length

5.2.1 Cooling

TOTAL TUBING LENGTH								
3m	7.5m	10m	15m	20m	25m	30m	40m	50m
1.02	1	0.99	0.975	0.965	0.950	---	---	---

* Minimum recommended tubing length between indoor and outdoor units is 3m.

5.2.2 Heating

TOTAL TUBING LENGTH								
3m	7.5m	10m	15m	20m	25m	30m	40m	50m
1.05	1	1	0.993	0.988	0.978	---	---	---

* Minimum recommended tubing length between indoor and outdoor units is 3m.

5.3 Pressure Curves.

5.3.1 Cooling.

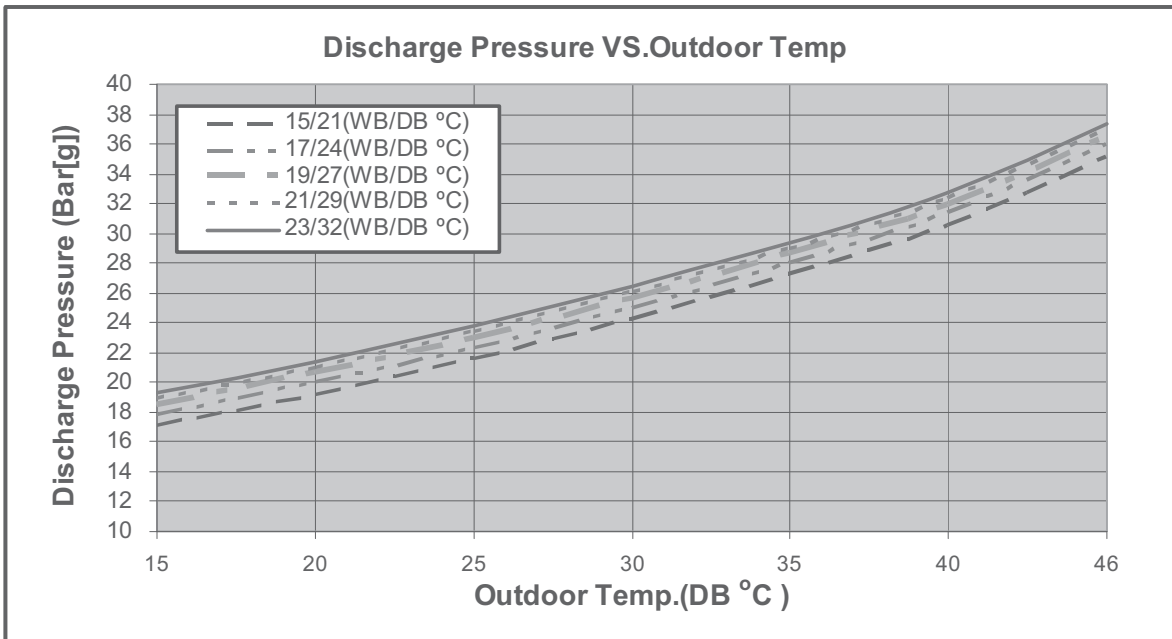
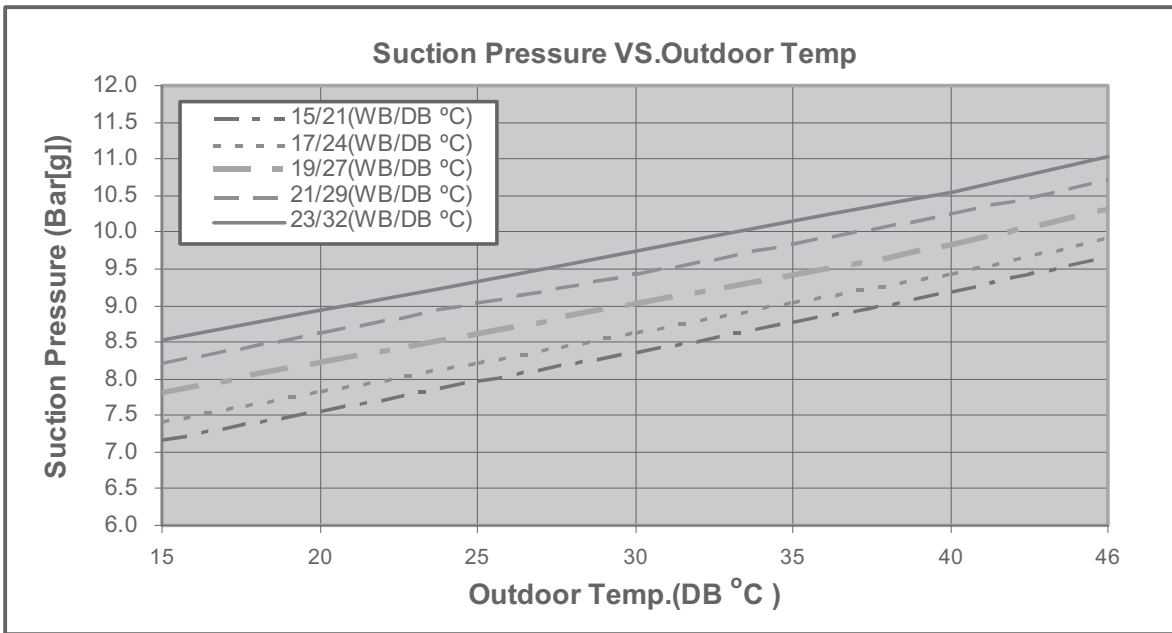

5.3.2 Heating.

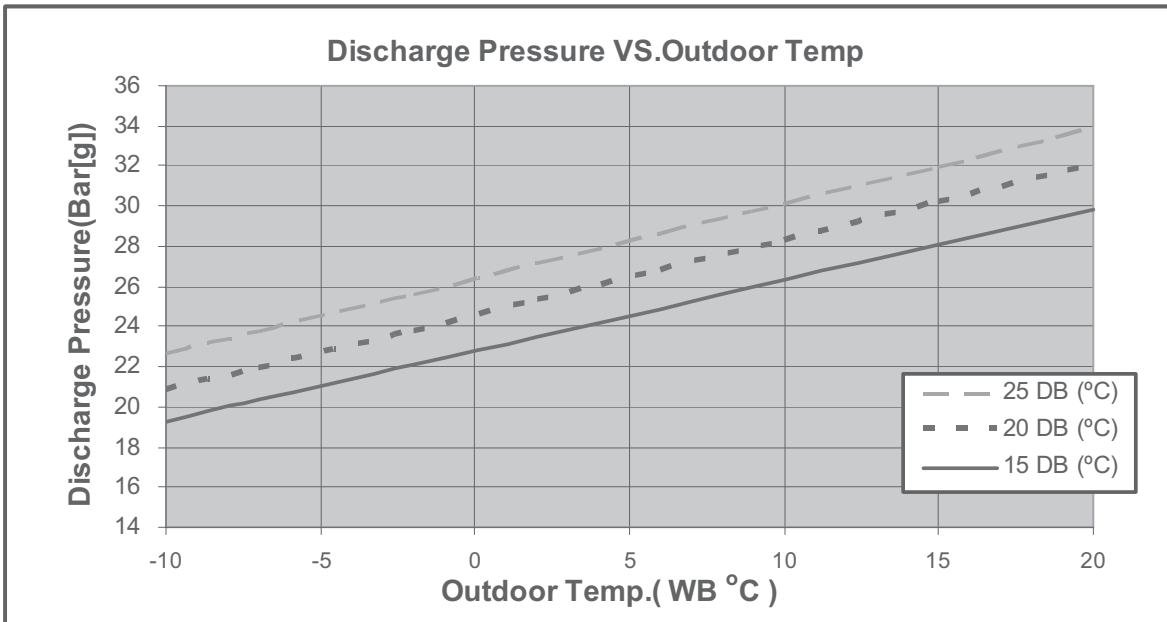
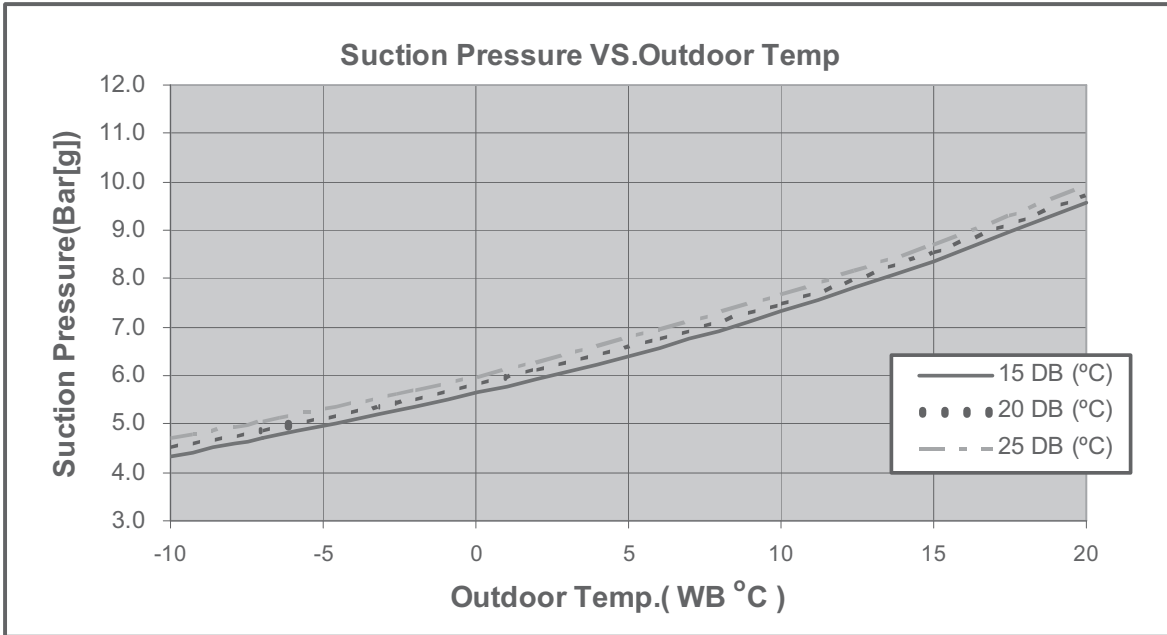

5.4 DELTA21 GC21 R410A

5.4.1 Cooling Mode at 7.5m Tubing Connection.

230V : Indoor Fan at High Speed.

ENTERING AIR DB OU COIL (°C)	DATA	ENTERING AIR WB/DB ID COIL (°C)				
		15/21	17/24	19/27	21/29	23/32
15 ⁽¹⁾	TC	6.53	6.77	6.93	7.09	7.20
	SC	4.45	4.64	4.82	4.94	5.03
	PI	1.45	1.46	1.46	1.46	1.47
20 ⁽¹⁾	TC	6.32	6.66	6.87	7.04	7.19
	SC	4.36	4.59	4.79	4.92	5.01
	PI	1.58	1.58	1.59	1.60	1.60
25	TC	5.98	6.46	6.79	7.00	7.17
	SC	4.25	4.51	4.75	4.89	4.98
	PI	1.71	1.72	1.73	1.74	1.75
30	TC	5.59	6.09	6.58	6.81	7.02
	SC	4.11	4.37	4.65	4.78	4.87
	PI	1.84	1.87	1.88	1.90	1.91
35	TC	5.18	5.62	6.20	6.51	6.82
	SC	3.91	4.19	4.54	4.67	4.76
	PI	1.98	2.02	2.05	2.07	2.08
40	TC	4.71	5.13	5.59	6.12	6.43
	SC	3.69	3.97	4.29	4.43	4.52
	PI	2.14	2.17	2.21	2.24	2.26
46	TC	4.09	4.47	4.91	5.43	5.85
	SC	3.40	3.64	3.92	4.05	4.14
	PI	2.34	2.37	2.43	2.46	2.49

LEGEND

- TC – Total Cooling Capacity, kW
- SC – Sensible Capacity, kW
- PI – Power Input, kW
- WB – Wet Bulb Temp., (°C)
- DB – Dry Bulb Temp., (°C)
- ID – Indoor
- OU – Outdoor

(1) Marked area is below standard operating limits. For operating in low ambient conditions, refer to Optional Accessories (Chapter 15).

5.4.2 Heating Mode at 7.5m Tubing Connection.

230V : Indoor Fan at High Speed.

ENTERING AIR WB OU COIL (°C)	ENTERING AIR DB ID COIL (°C)					
	15		20		25	
	TH	PI	TH	PI	TH	PI
-10	3.41	1.60	3.28	1.70	3.15	1.79
-7	3.67	1.64	3.54	1.73	3.41	1.82
-2	3.90	1.66	3.77	1.76	3.64	1.86
2	4.75	1.74	4.55	1.85	4.36	1.96
6	6.70	1.87	6.50	2.00	6.27	2.12
10	7.28	1.97	7.09	2.11	6.89	2.26
15	7.87	2.06	7.67	2.22	7.48	2.36
20	8.29	2.12	8.09	2.30	7.87	2.48

* the above chart includes the weighted deicing influence.

LEGEND

- TH – Total Heating Capacity, kW
- PI – Power Input, kW
- WB – Wet Bulb Temp., (°C)
- DB – Dry Bulb Temp., (°C)
- ID – Indoor
- OU – Outdoor

5.5 Capacity Correction Factor Due to Tubing Length

5.5.1 Cooling

TOTAL TUBING LENGTH								
3m	7.5m	10m	15m	20m	25m	30m	40m	50m
1.02	1	0.961	0.950	---	---	---	---	---

* Minimum recommended tubing length between indoor and outdoor units is 3m.

5.5.2 Heating

TOTAL TUBING LENGTH								
3m	7.5m	10m	15m	20m	25m	30m	40m	50m
1.04	1	0.975	0.961	---	---	---	---	---

* Minimum recommended tubing length between indoor and outdoor units is 3m.

5.6 Pressure Curves.

5.6.1 Cooling.

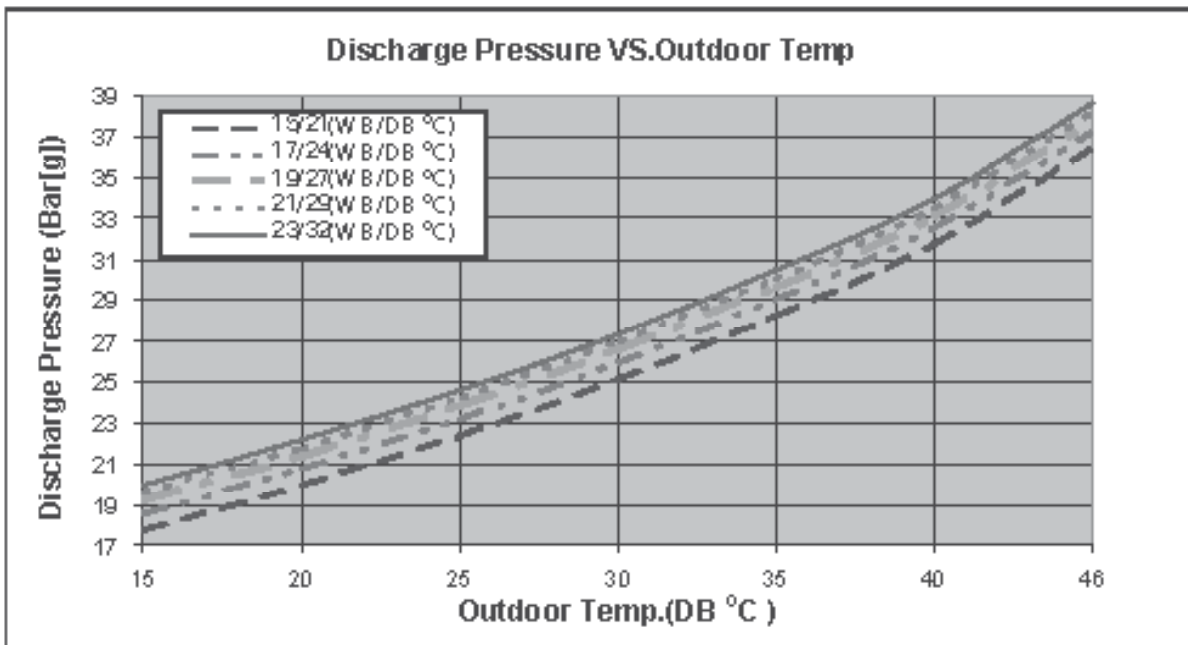
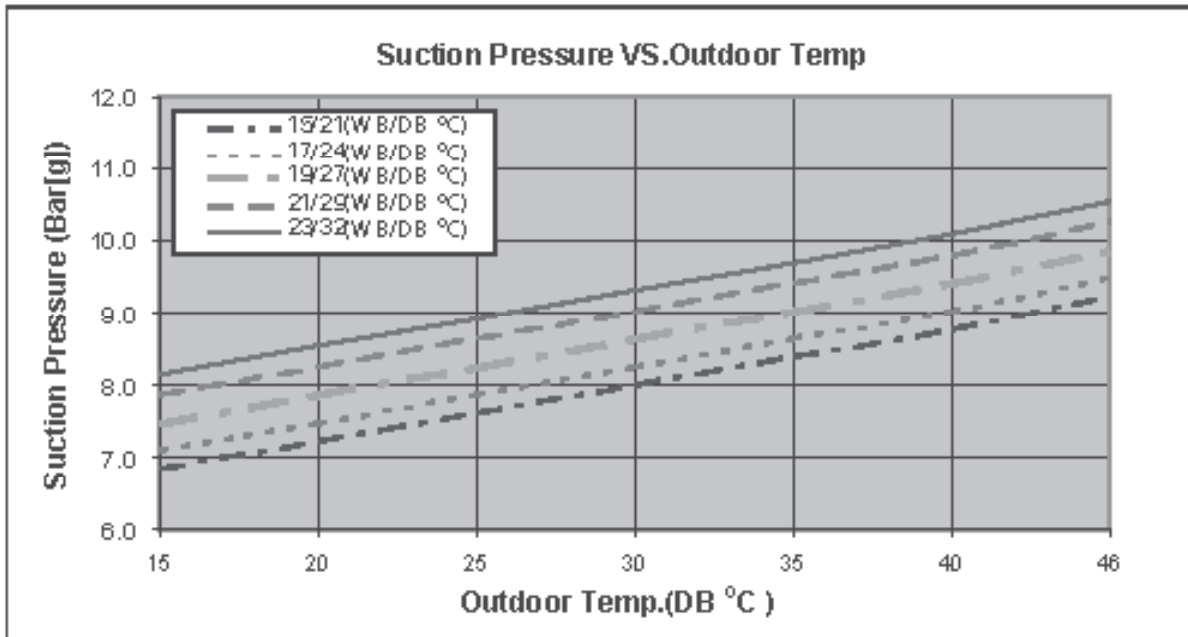

5.6.2 Heating.

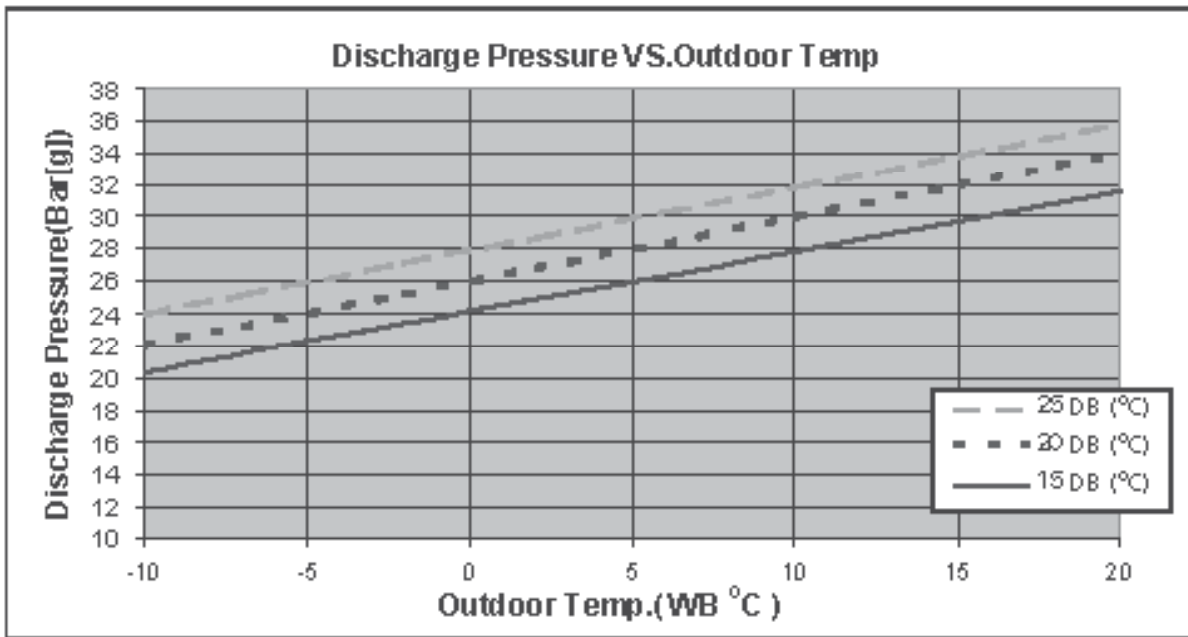
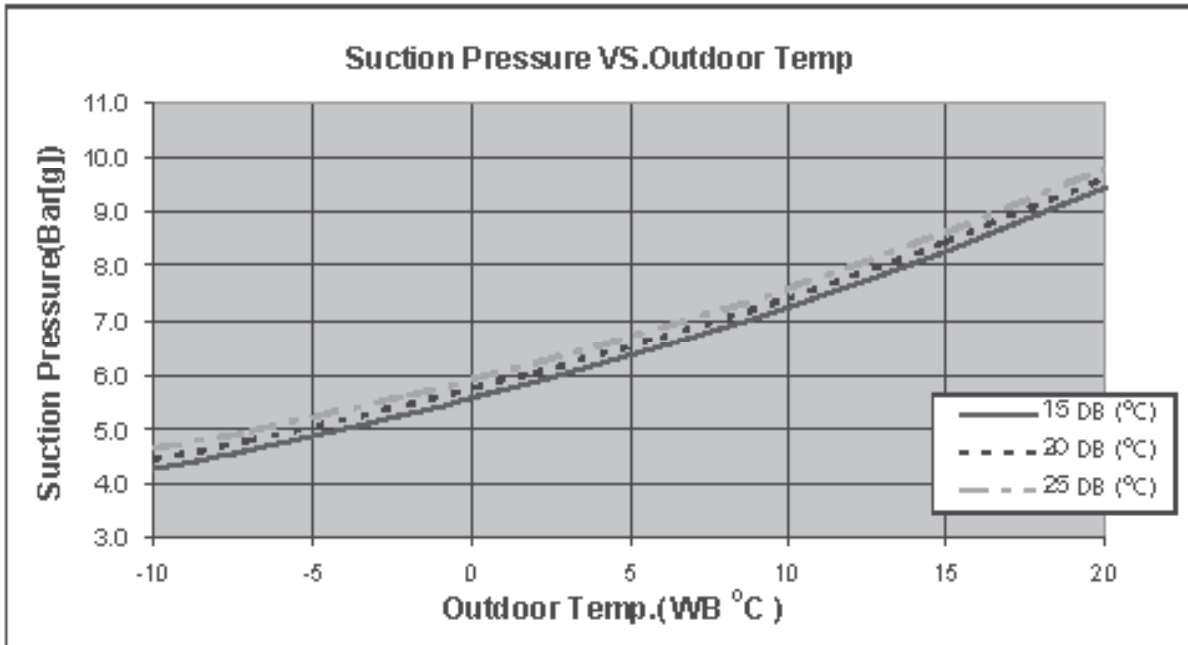

5.7 DELTA24 / OU7- 24, DELTA24 / OU7-24Z 1PH/3PH R410A

5.7.1 Cooling Mode at 7.5m Tubing Connection.

230V : Indoor Fan at High Speed.

ENTERING AIR DB OU COIL (°C)	DATA	ENTERING AIR WB/DB ID COIL (°C)				
		15/21	17/24	19/27	21/29	23/32
15 ⁽¹⁾	TC	7.14	7.39	7.57	7.74	7.86
	SC	4.80	5.00	5.20	5.33	5.43
	PI	1.59	1.59	1.59	1.60	1.61
20 ⁽¹⁾	TC	6.90	7.28	7.51	7.68	7.85
	SC	4.70	4.96	5.17	5.31	5.41
	PI	1.72	1.73	1.74	1.75	1.75
25	TC	6.53	7.05	7.42	7.64	7.83
	SC	4.58	4.86	5.13	5.28	5.37
	PI	1.86	1.88	1.89	1.90	1.91
30	TC	6.11	6.65	7.19	7.44	7.66
	SC	4.44	4.72	5.02	5.16	5.26
	PI	2.01	2.04	2.06	2.07	2.09
35	TC	5.66	6.14	6.77	7.11	7.45
	SC	4.22	4.52	4.90	5.04	5.14
	PI	2.17	2.20	2.24	2.26	2.27
40	TC	5.14	5.60	6.11	6.68	7.02
	SC	3.98	4.28	4.64	4.78	4.88
	PI	2.34	2.37	2.41	2.44	2.47
46	TC	4.46	4.88	5.37	5.93	6.39
	SC	3.66	3.93	4.23	4.37	4.47
	PI	2.55	2.59	2.65	2.69	2.72

LEGEND

- TC – Total Cooling Capacity, kW
- SC – Sensible Capacity, kW
- PI – Power Input, kW
- WB – Wet Bulb Temp., (°C)
- DB – Dry Bulb Temp., (°C)
- ID – Indoor
- OU – Outdoor

(1) Marked area is below standard operating limits. For operating in low ambient conditions, refer to Optional Accessories (Chapter 15).

5.7.2 Heating Mode at 7.5m Tubing Connection.

230V : Indoor Fan at High Speed.

ENTERING AIR WB OU COIL (°C)	ENTERING AIR DB ID COIL (°C)					
	15		20		25	
	TH	PI	TH	PI	TH	PI
-10	3.72	1.88	3.58	2.00	3.43	2.10
-7	4.00	1.93	3.86	2.03	3.72	2.14
-2	4.25	1.95	4.11	2.07	3.96	2.19
2	5.17	2.04	4.96	2.17	4.74	2.30
6	7.29	2.20	7.08	2.35	6.83	2.50
10	7.93	2.32	7.72	2.48	7.50	2.65
15	8.57	2.42	8.35	2.61	8.14	2.77
20	9.03	2.49	8.81	2.70	8.57	2.91

* the above chart includes the weighted deicing influence.

LEGEND

- TH – Total Heating Capacity, kW
- PI – Power Input, kW
- WB – Wet Bulb Temp., (°C)
- DB – Dry Bulb Temp., (°C)
- ID – Indoor
- OU – Outdoor

5.8 Capacity Correction Factor Due to Tubing Length

5.8.1 Cooling

TOTAL TUBING LENGTH								
3m	7.5m	10m	15m	20m	25m	30m	40m	50m
1.01	1	0.980	0.970	0.960	---	---	---	---

* Minimum recommended tubing length between indoor and outdoor units is 3m.

5.8.2 Heating

TOTAL TUBING LENGTH								
3m	7.5m	10m	15m	20m	25m	30m	40m	50m
1.02	1	0.990	0.990	0.980	---	---	---	---

* Minimum recommended tubing length between indoor and outdoor units is 3m.

5.9 Pressure Curves.

5.9.1 Cooling.

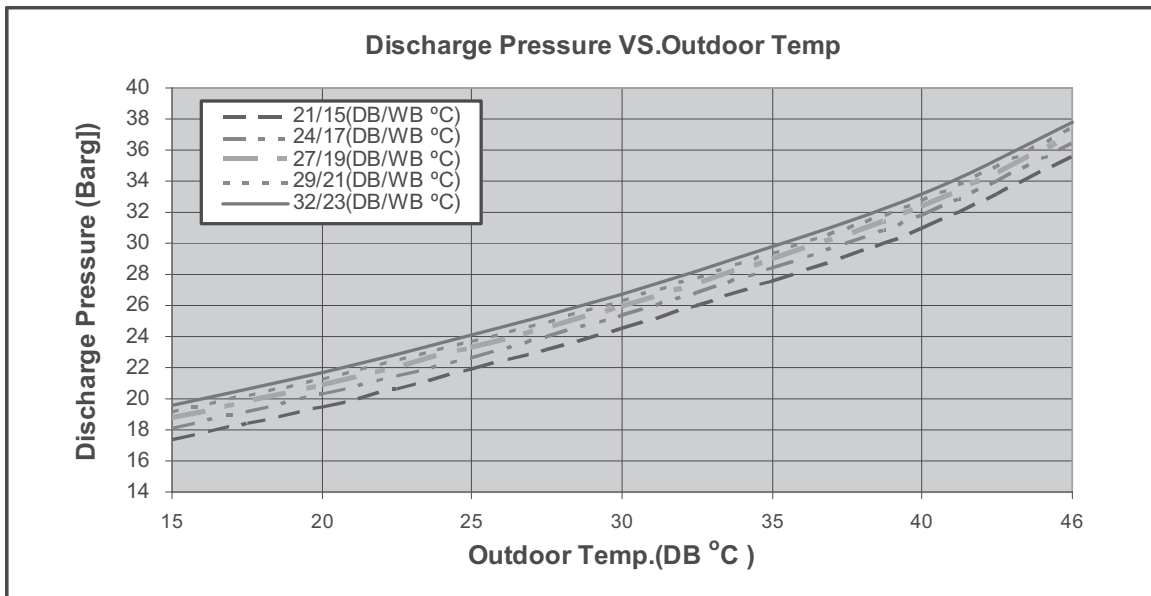
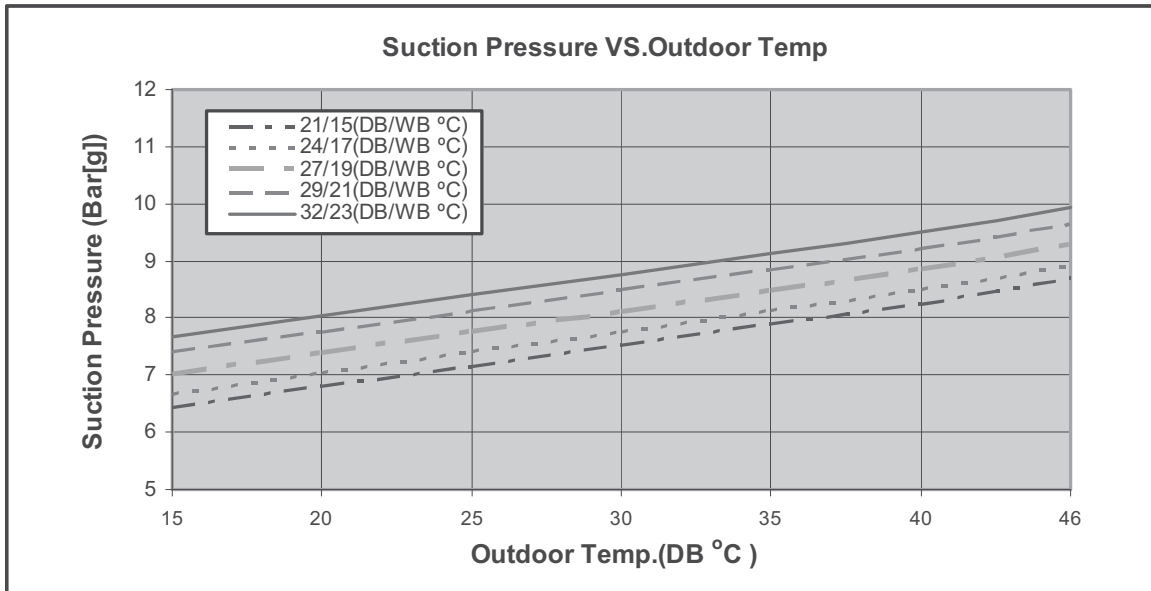

5.9.2 Heating.

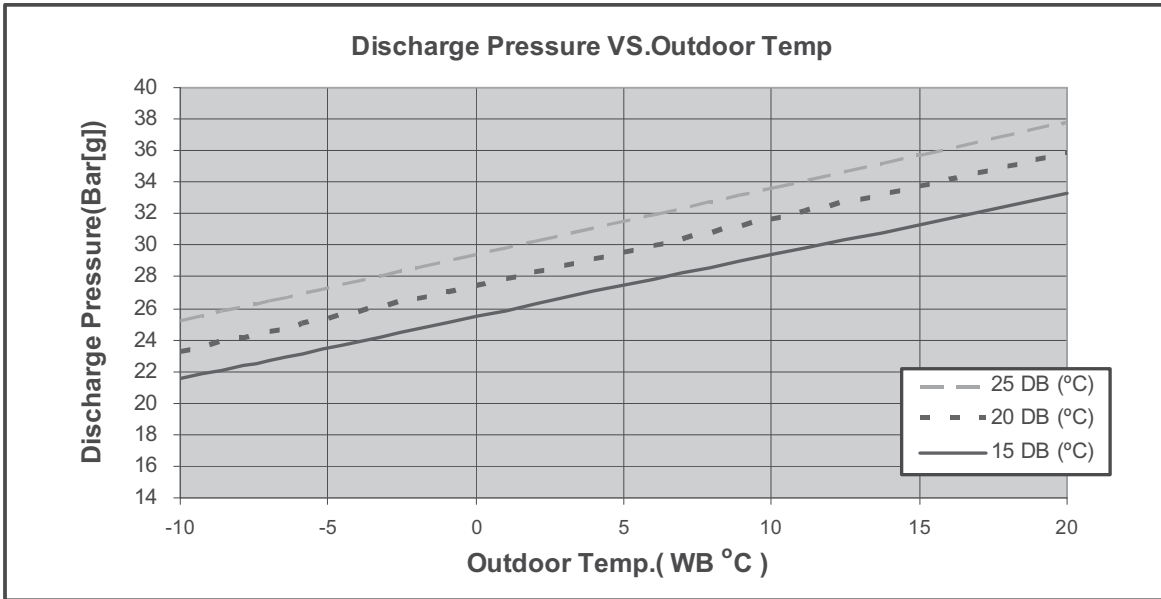
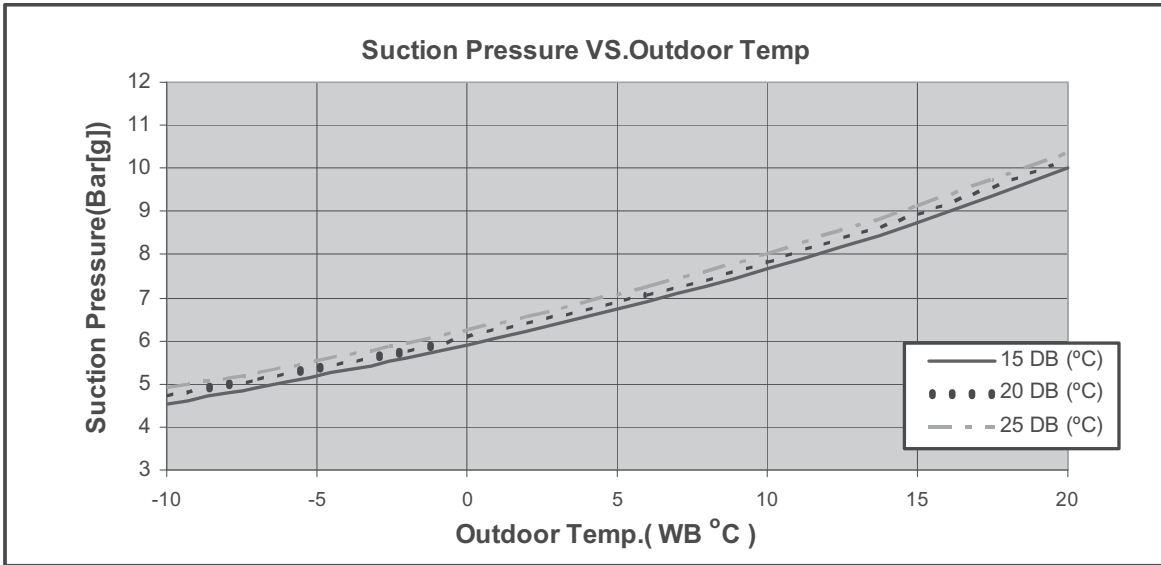

6. SOUND LEVEL CHARACTERISTICS

6.1 Sound Pressure Level

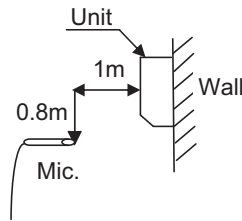

FAN SPEED	LINE
HI	▲
ME	○
LO	□

Figure 1

6.2 Sound Pressure Level Spectrum (Measured as Figure 1)

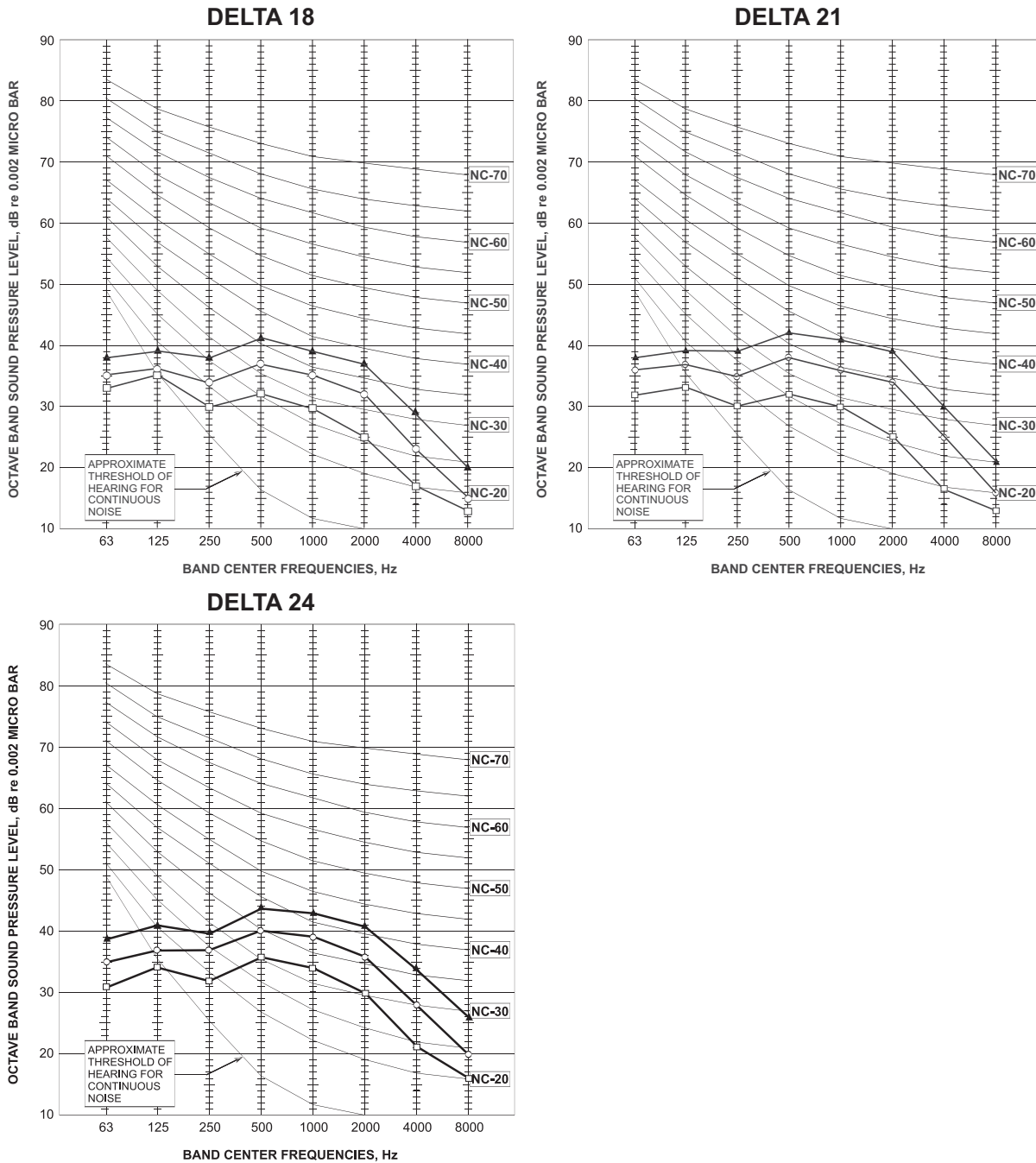

6.3 Outdoor units

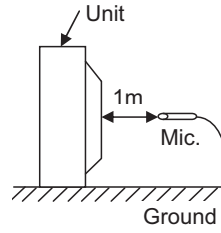
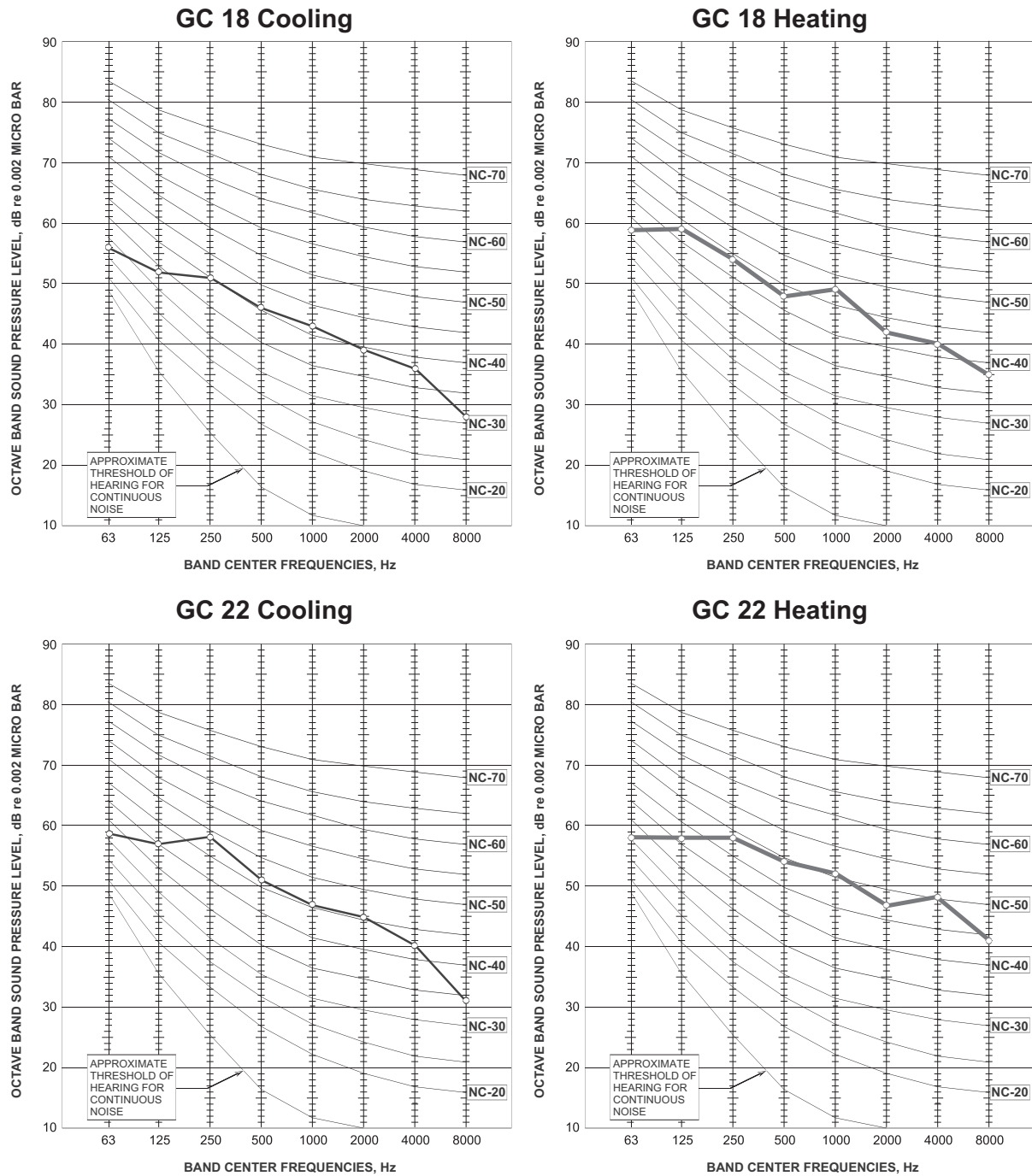
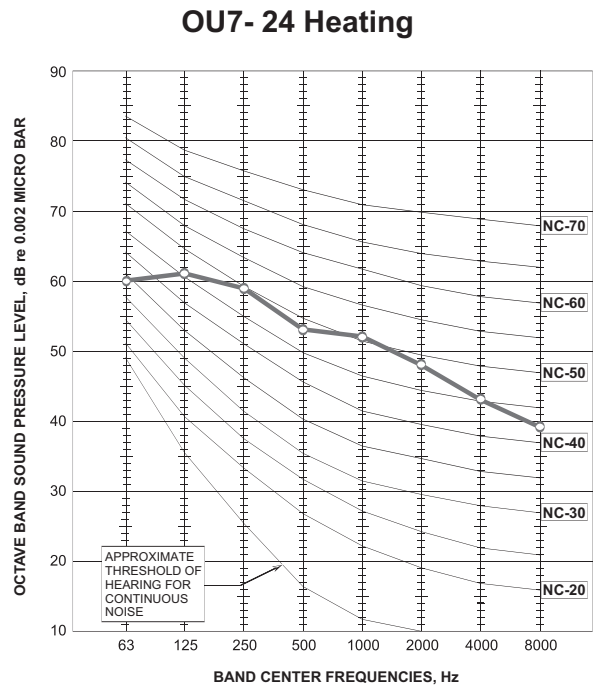
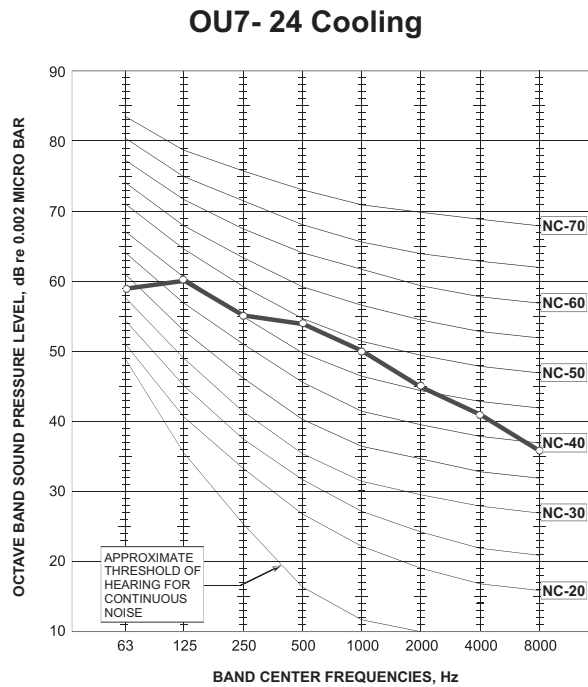
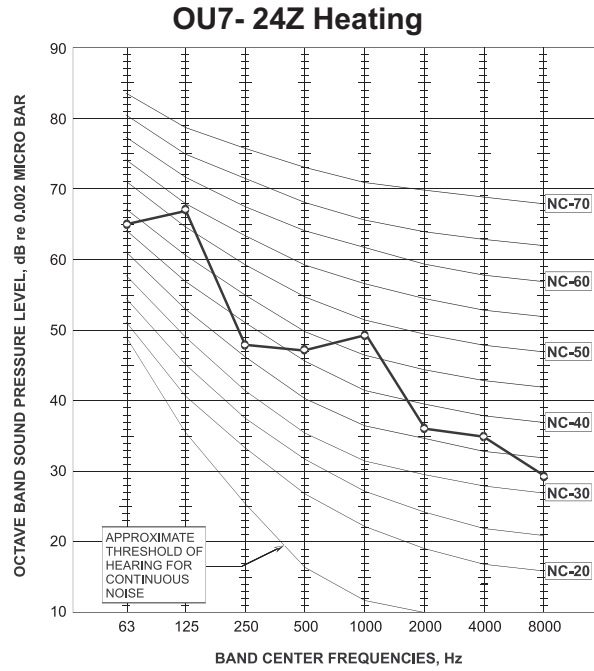
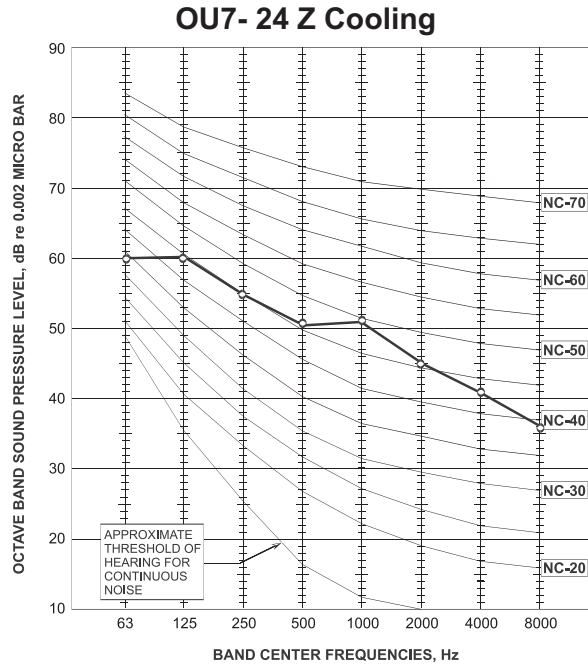

Figure 2

6.4 Sound Pressure Level Spectrum (Measured as Figure 2)



Sound Pressure Level Spectrum (Measured as Figure 2)



7. ELECTRICAL DATA

7.1 Single Phase Units

MODEL	DELTA 18	DELTA 21/24	DELTA 21/24
Power Supply	To indoor	To Outdoor	To Outdoor
	1PH-230V-50Hz	1PH-230V-50Hz	3PH-400V-50Hz
Max Current, A	11.1	14	3×6
Circuit Breaker,A	15	20	3×10
Power Supply Wiring No. X Cross Section mm ²	3×1.5 mm ²	3×2.5 mm ²	5×1.5 mm ²
Interconnecting Cable RC Model No. X Cross Section mm ²	5×1.5 mm ² + 2×0.5 mm ² (OCT sensor)	6×1.5 mm ² + 2×0.5 mm ² (OCT sensor)	6×1.5 mm ² + 2×0.5 mm ² (OCT sensor)
Interconnecting Cable ST Model No. X Cross Section mm ²	4×1.5 mm ²	5×1.5 mm ² + 2×0.5 mm ²	5×1.5 mm ² + 2×0.5 mm ² (OCT sensor)

NOTE

Power wiring cord should comply with local laws and electrical regulations requirements.

8. WIRING DIAGRAMS

8.1 Indoor Unit: DELTA 18, 21, 24

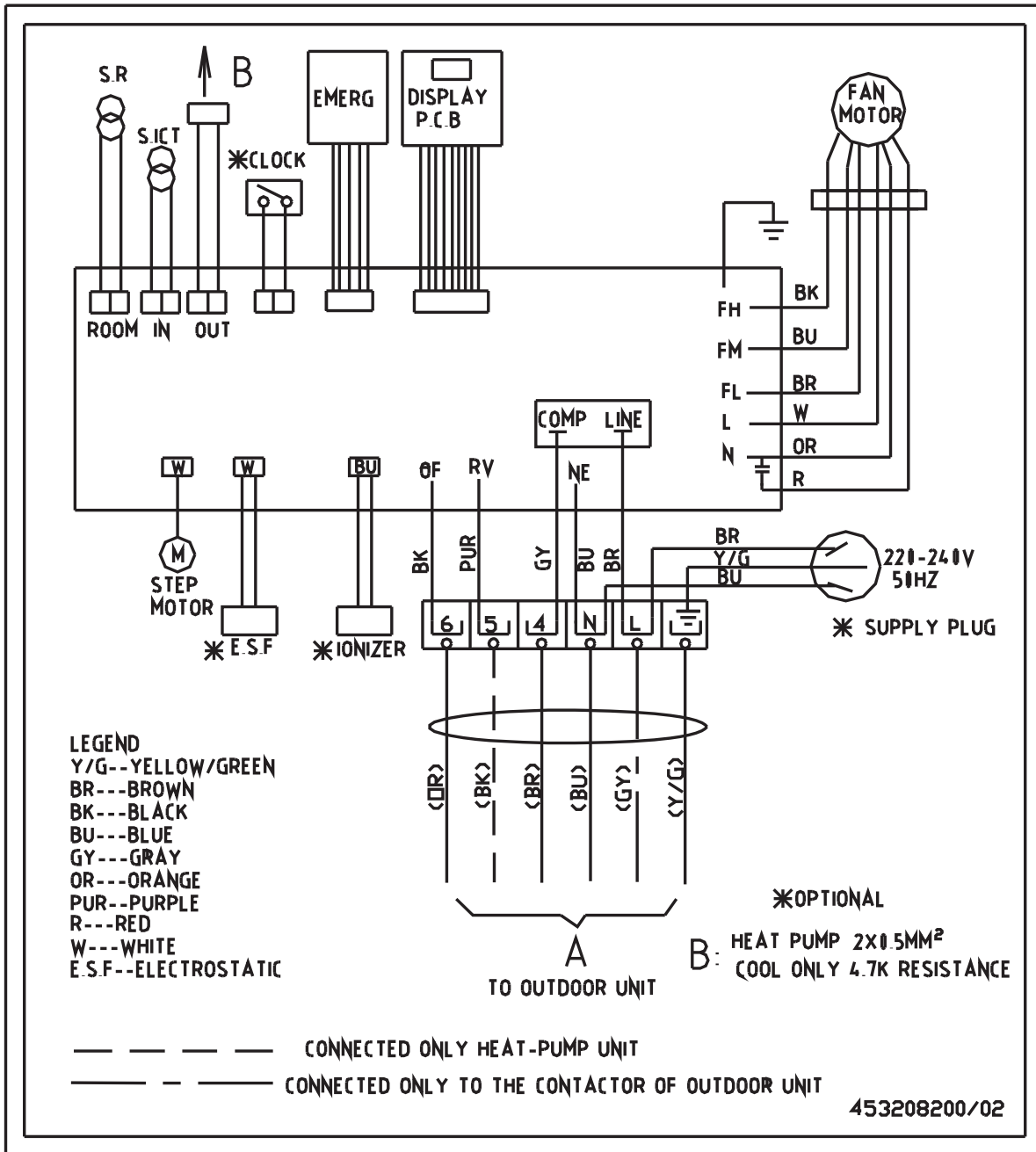

8.2 Outdoor Unit: GC 18 1PH R410A

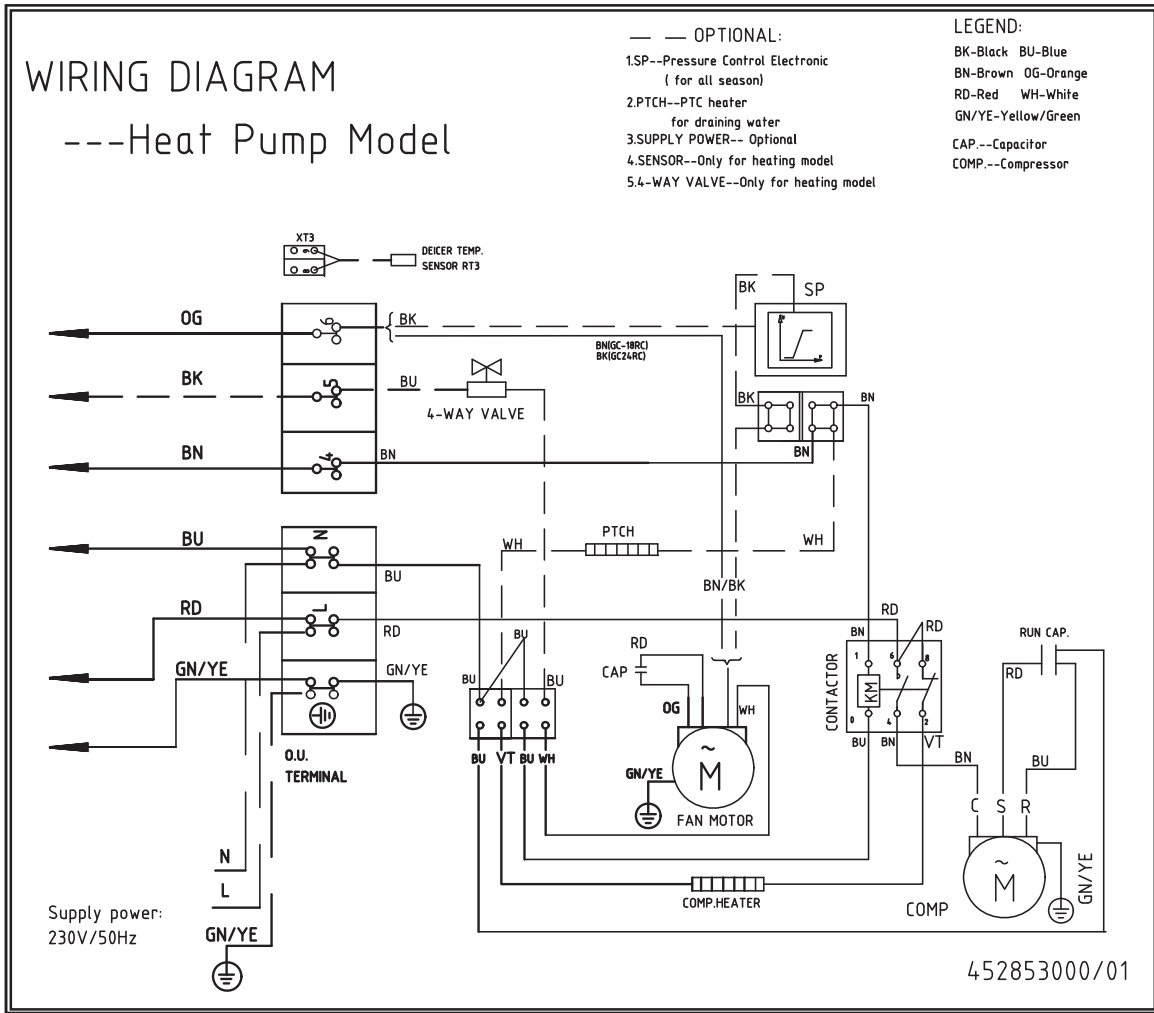

8.3 Outdoor Unit: GC 24 1PH R410A

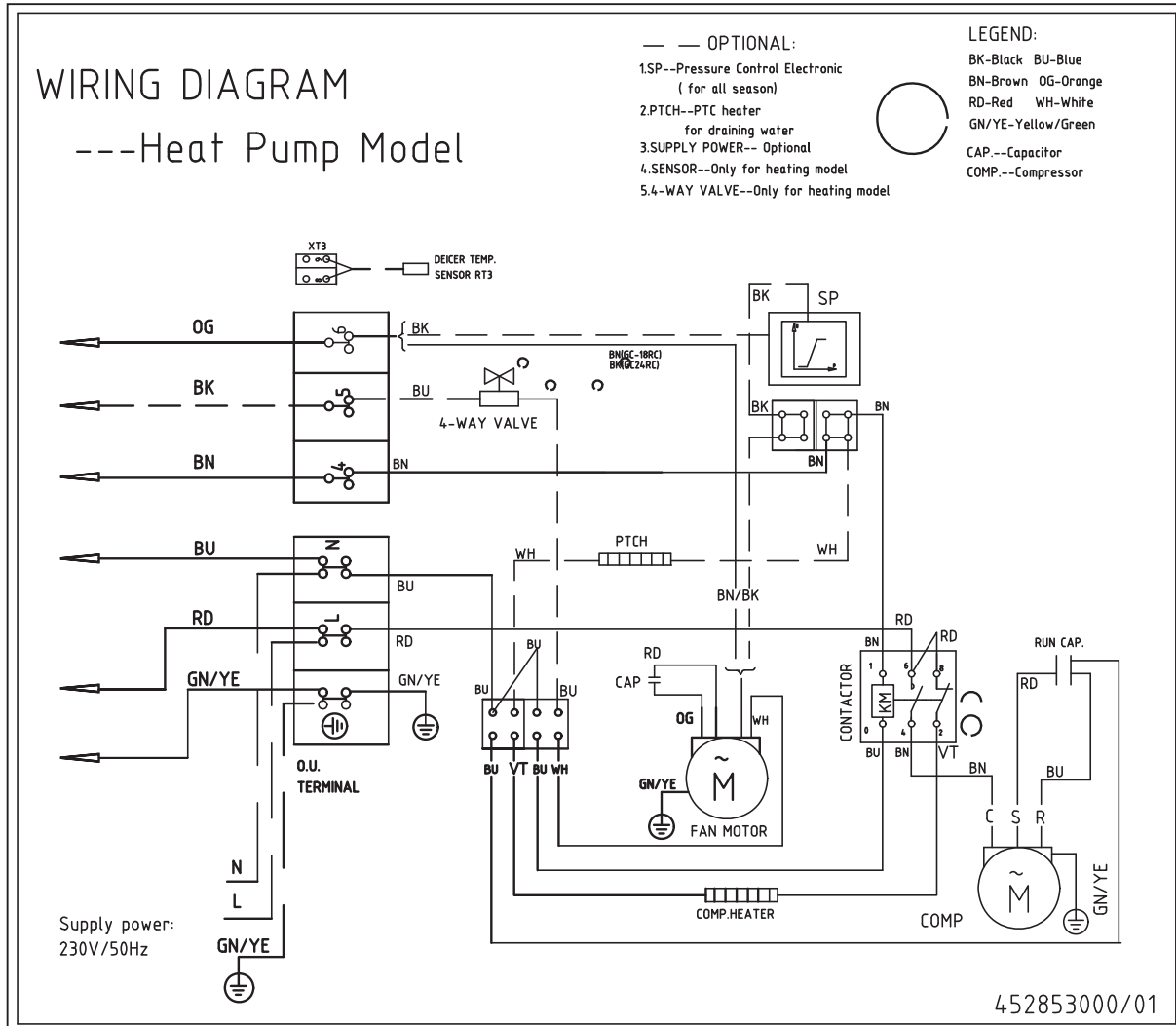

8.4 Outdoor Unit: OU7-24 1PH R410A

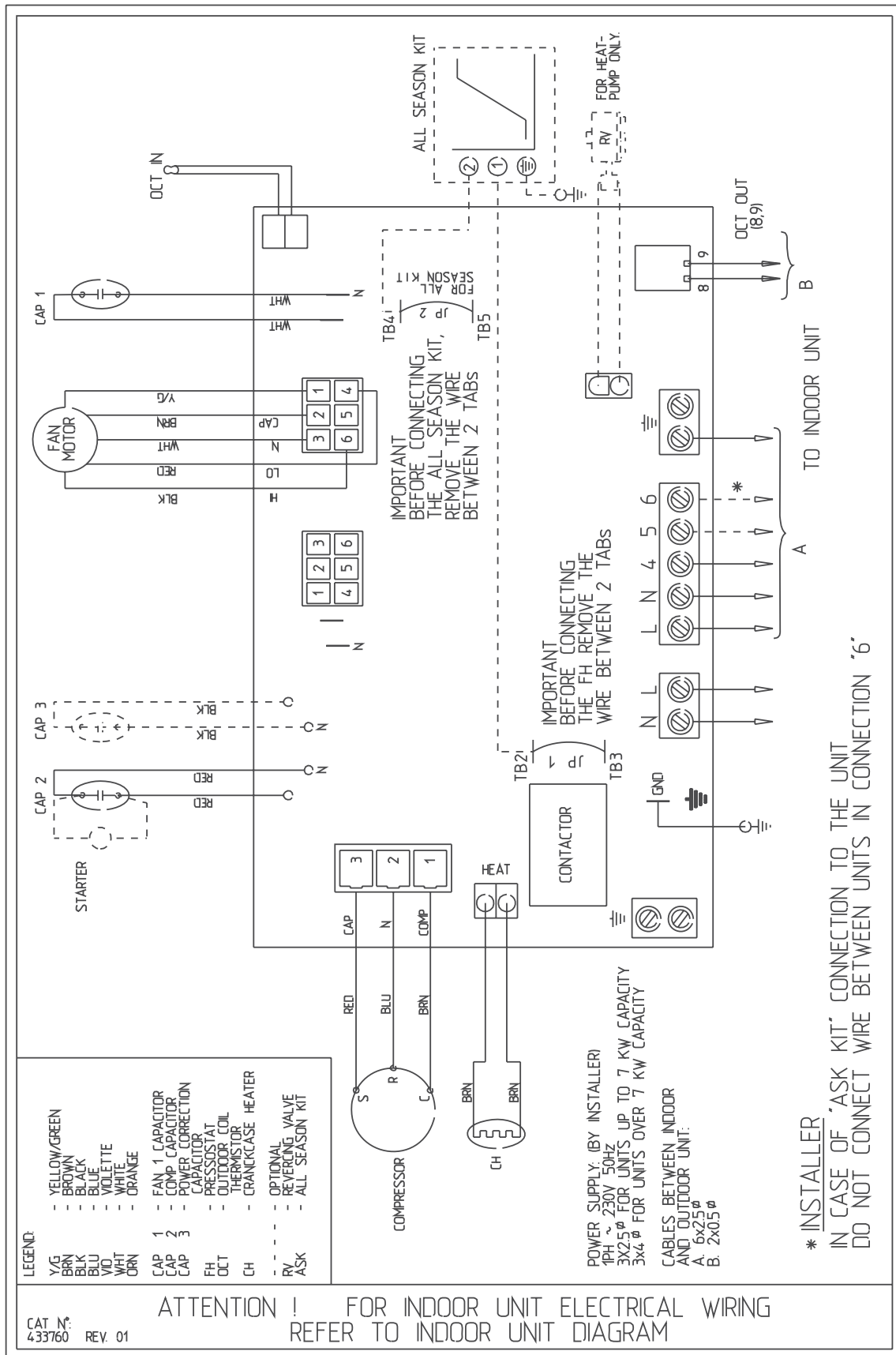

8.5 Outdoor Unit: OU7-24 3PH R410A

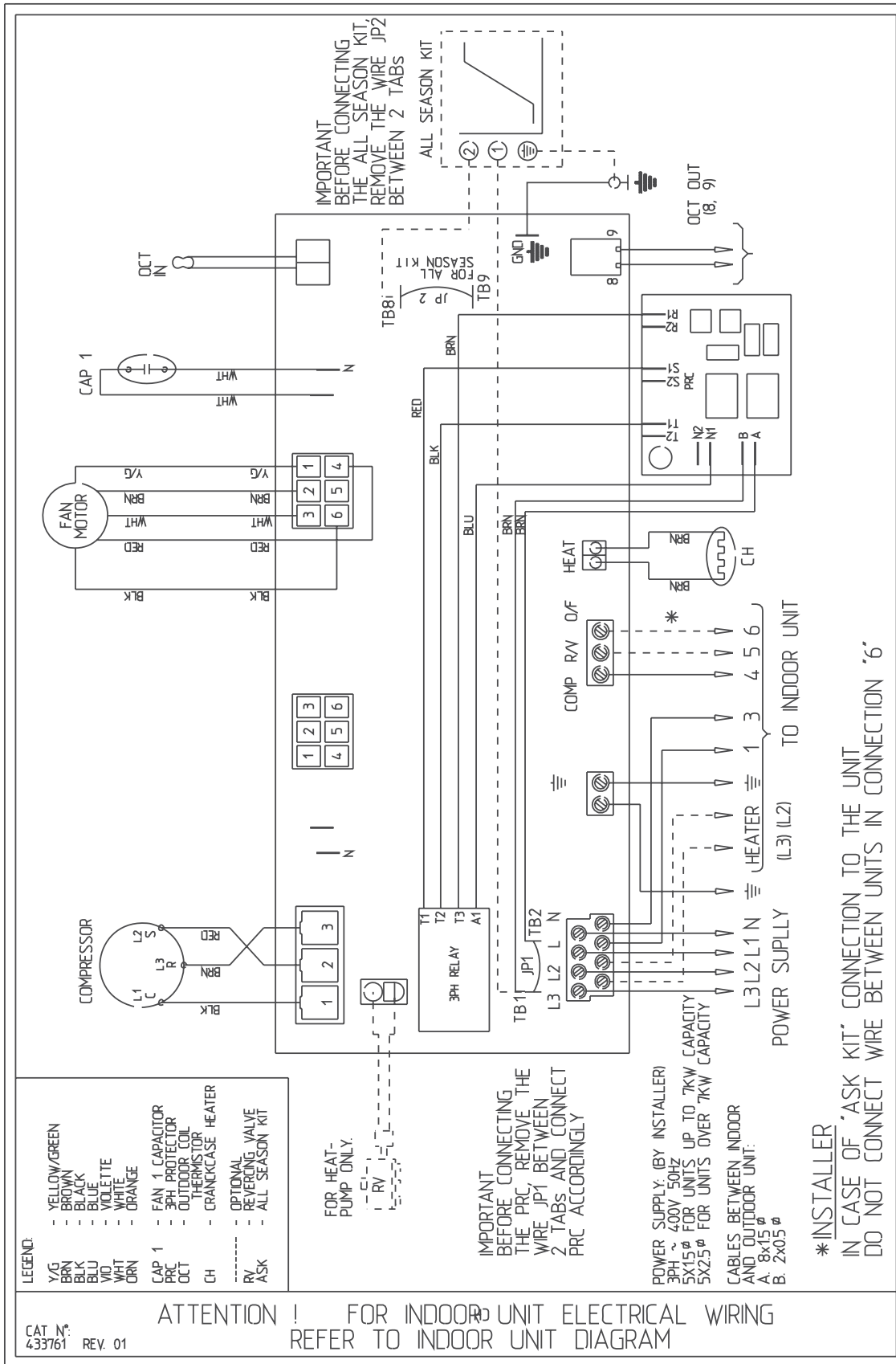

8.6 Outdoor Unit: OU7-24Z R410A

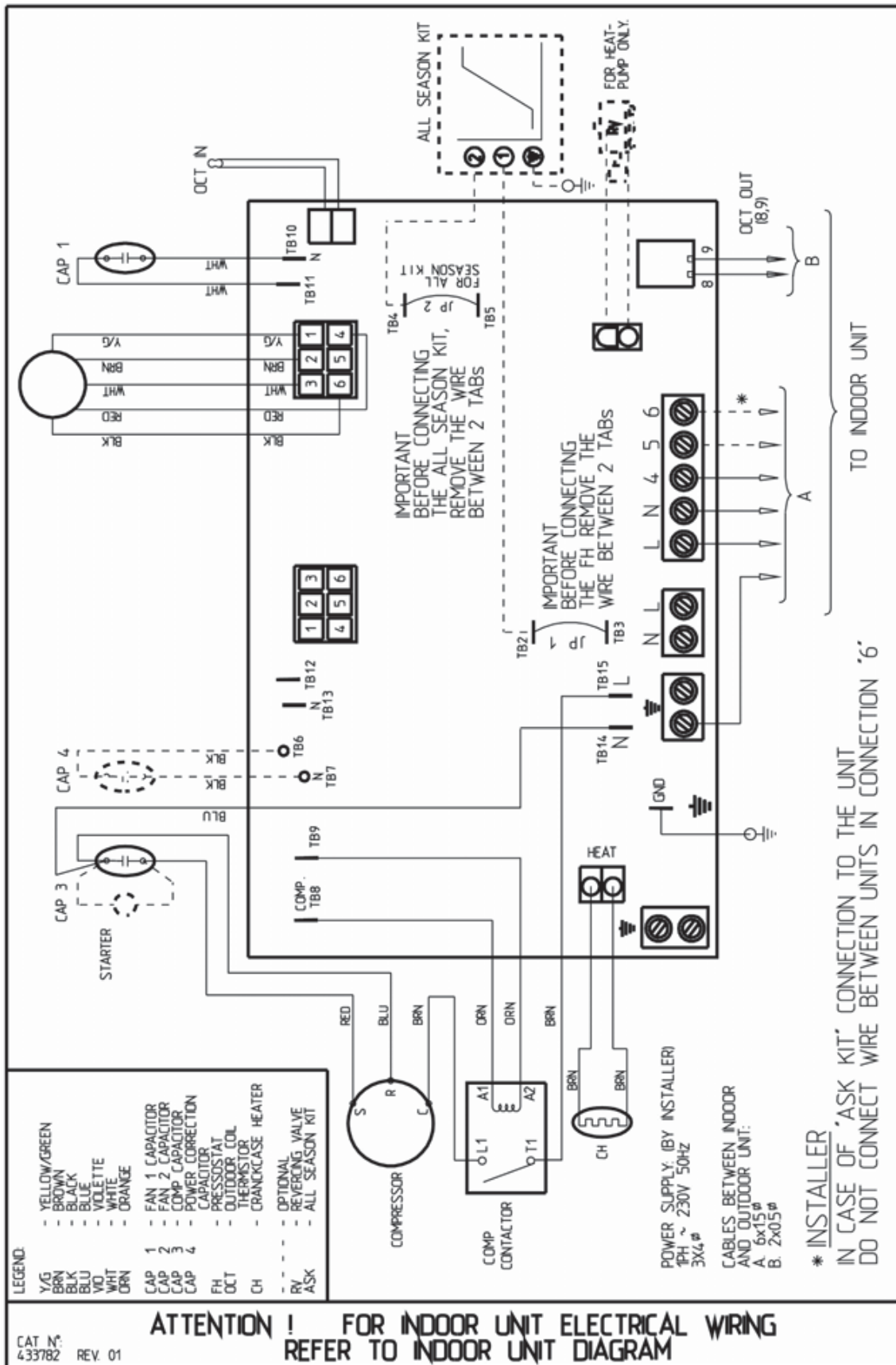

9. ELECTRICAL CONNECTIONS

9.1 DELTA 18 / 21 1PH

INDOOR UNIT

POWER SUPPLY
1PH 220-240V 50Hz

OUTDOOR UNIT

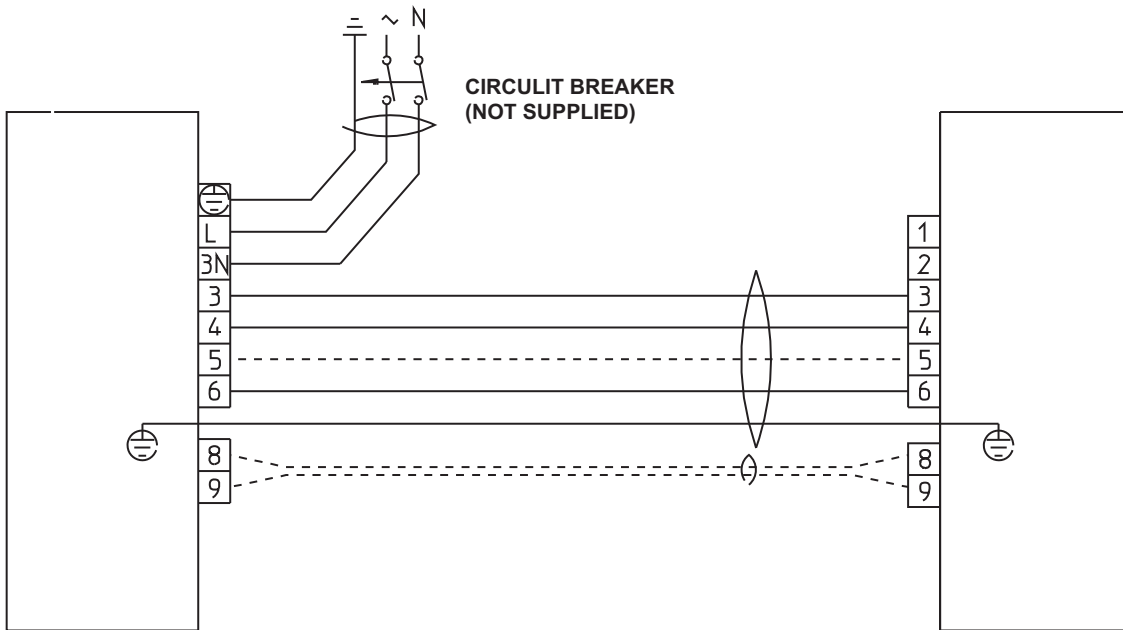

CONNECTED ONLY
HEAT - PUMP UNIT

9.2 DELTA 24 1PH (power supply to Outdoor unit)

INDOOR UNIT

POWER SUPPLY
1PH 220-240V 50Hz

OUTDOOR UNIT

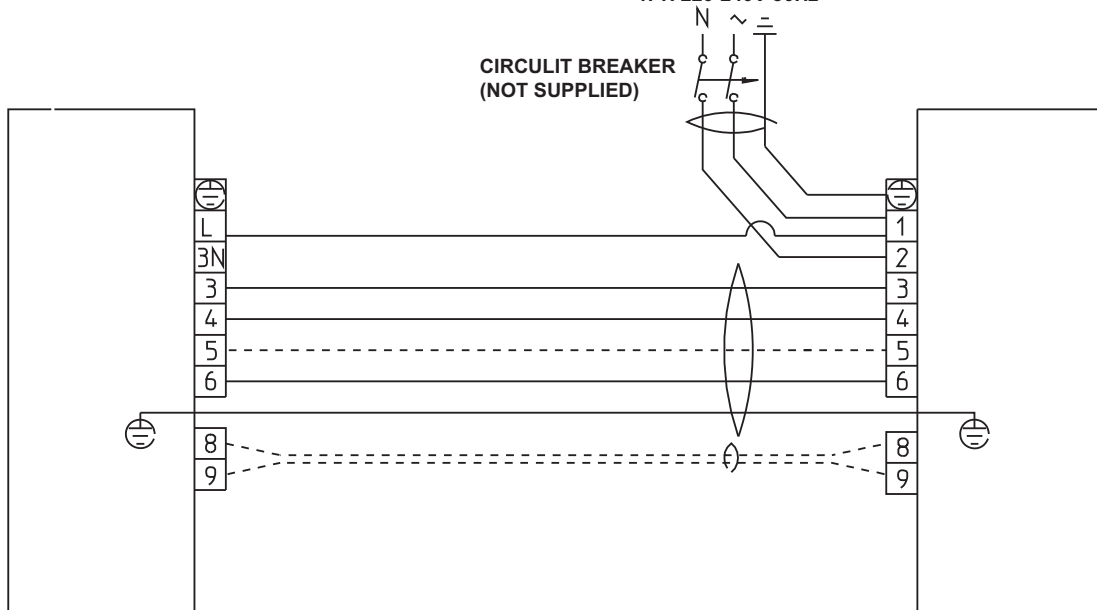

CONNECTED ONLY
HEAT - PUMP UNIT

10. REFRIGERATION DIAGRAMS

10.1 Heat Pump Models

10.1.1 DELTA 18 R410A

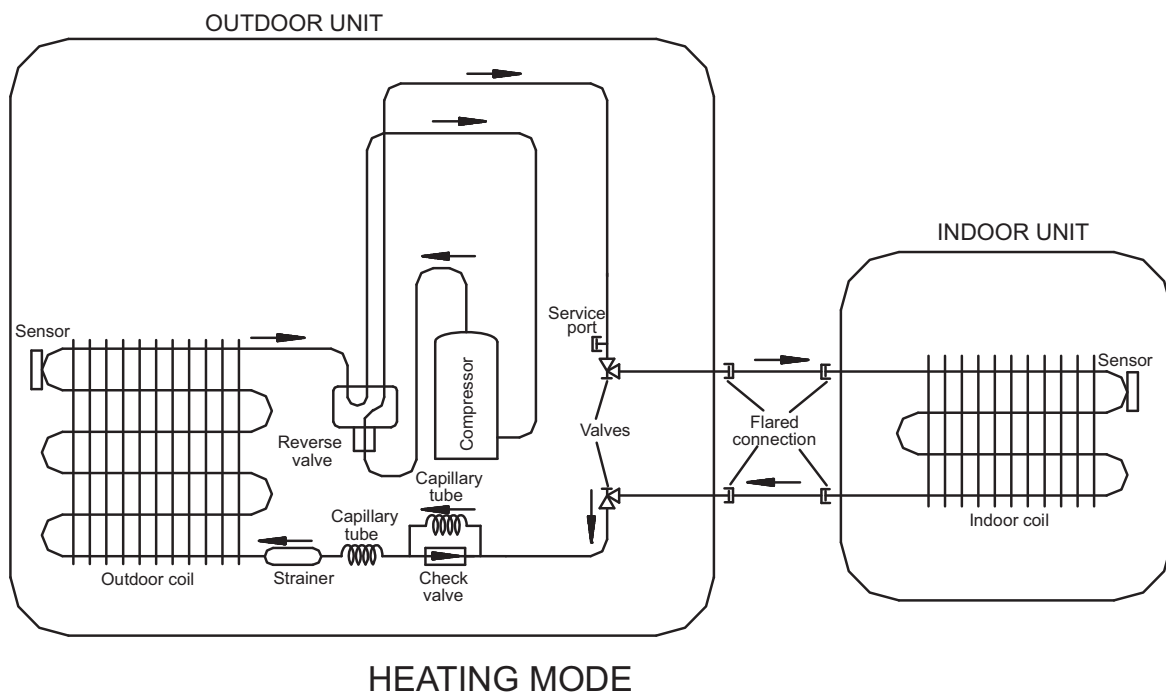
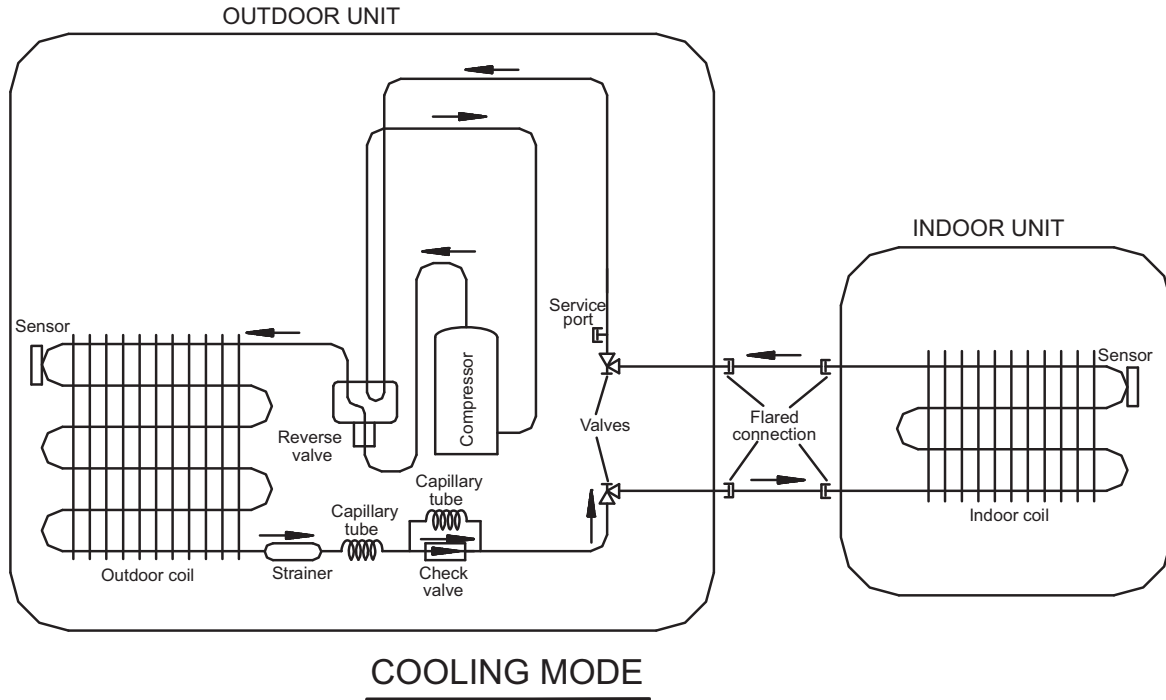

10.1.2 DELTA 24 / OU7-24 R410A

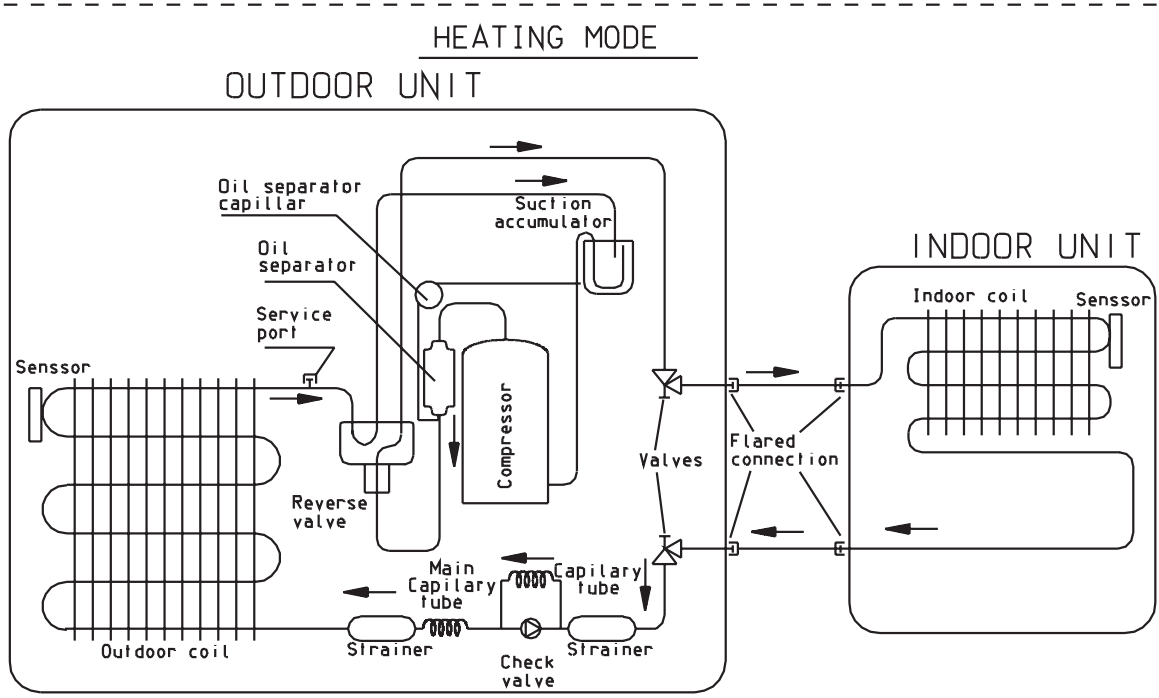
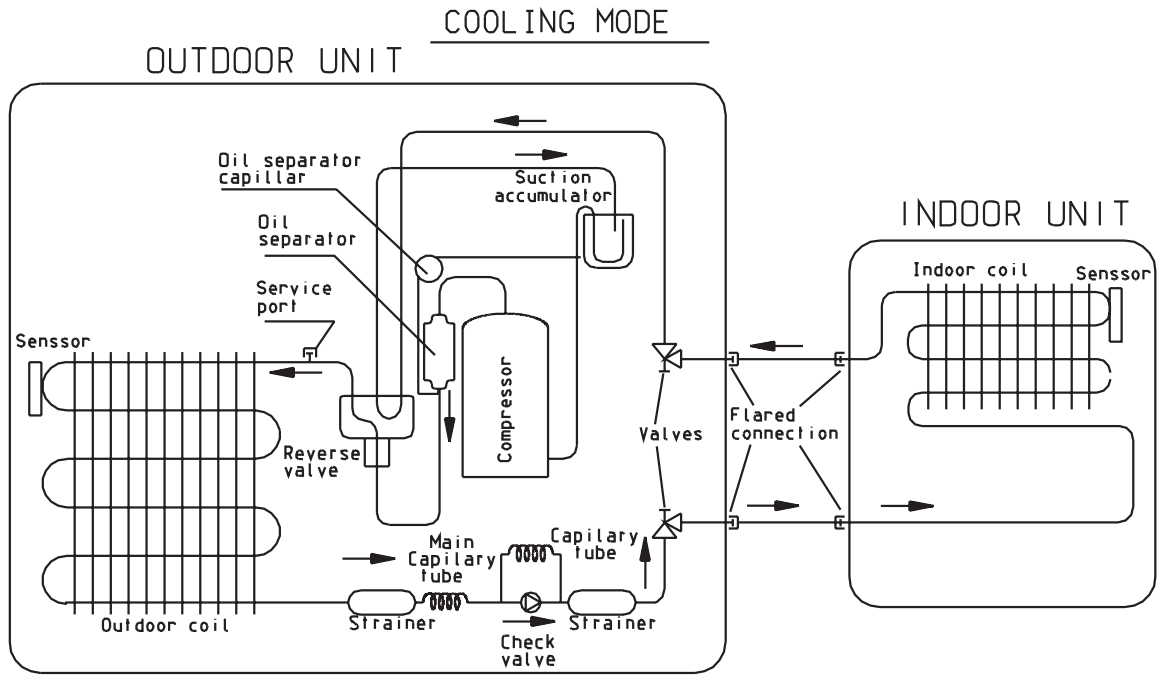

10.1.3 DELTA 24 / OU7-24Z R410A

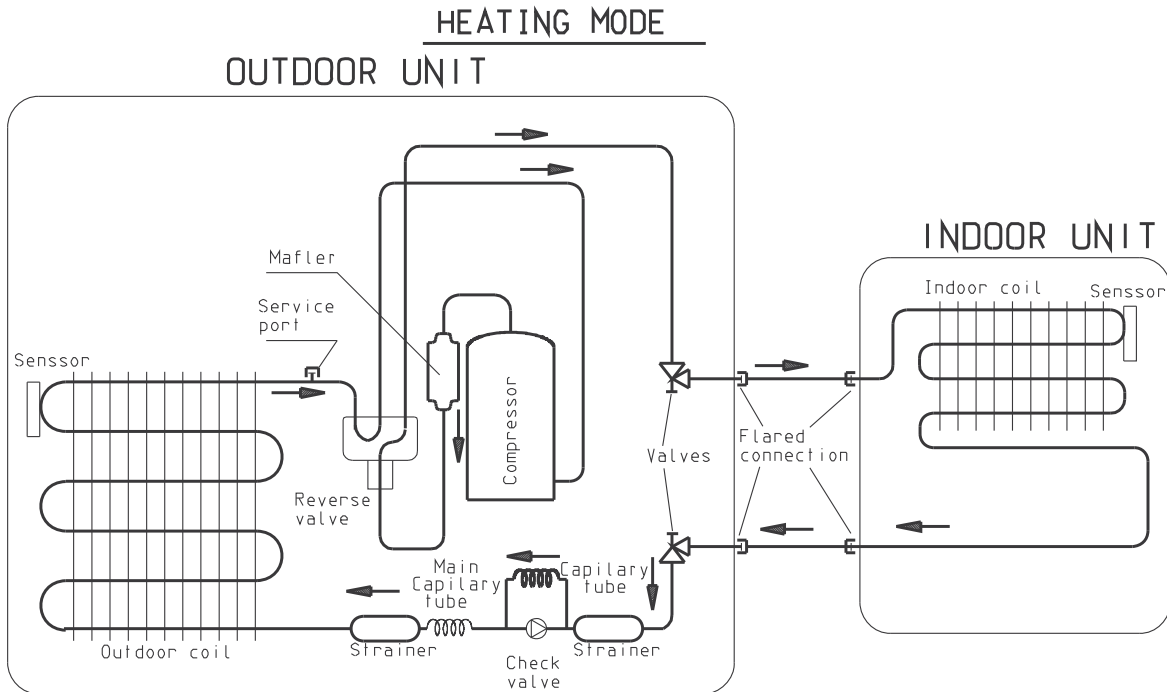
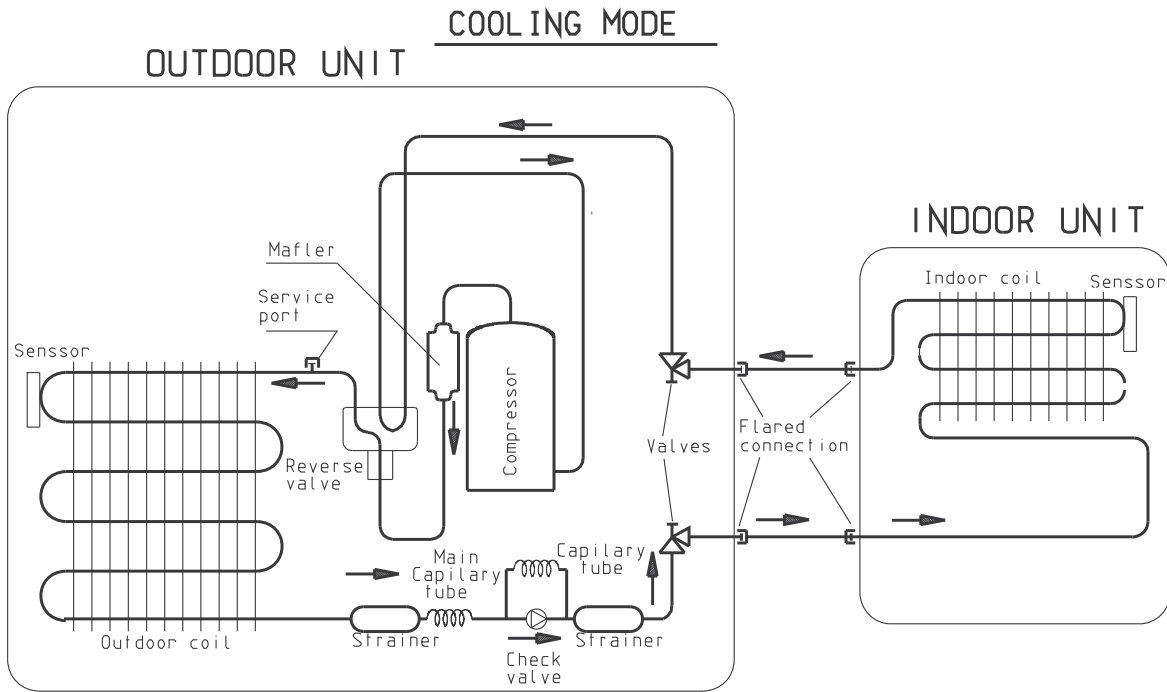

10.2 Cooling Only Models

10.2.1 DELTA 18, 21, 24 R410A

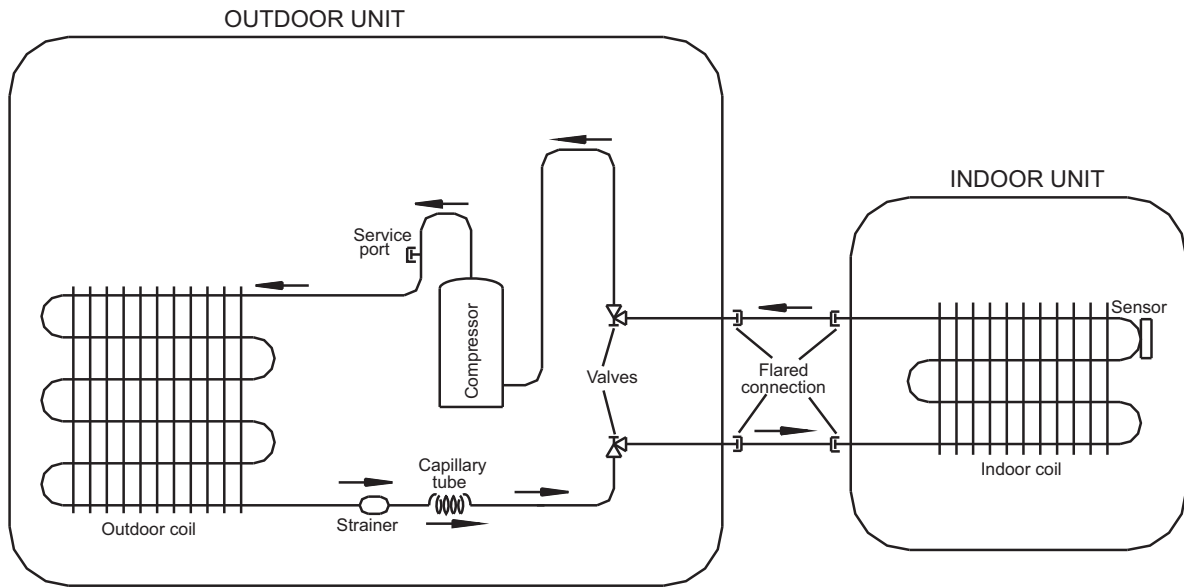

11. TUBING CONNECTIONS

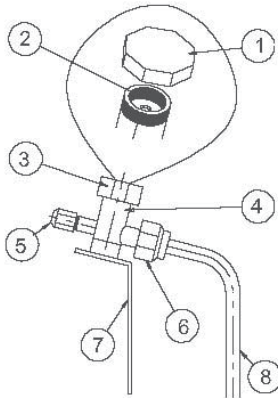
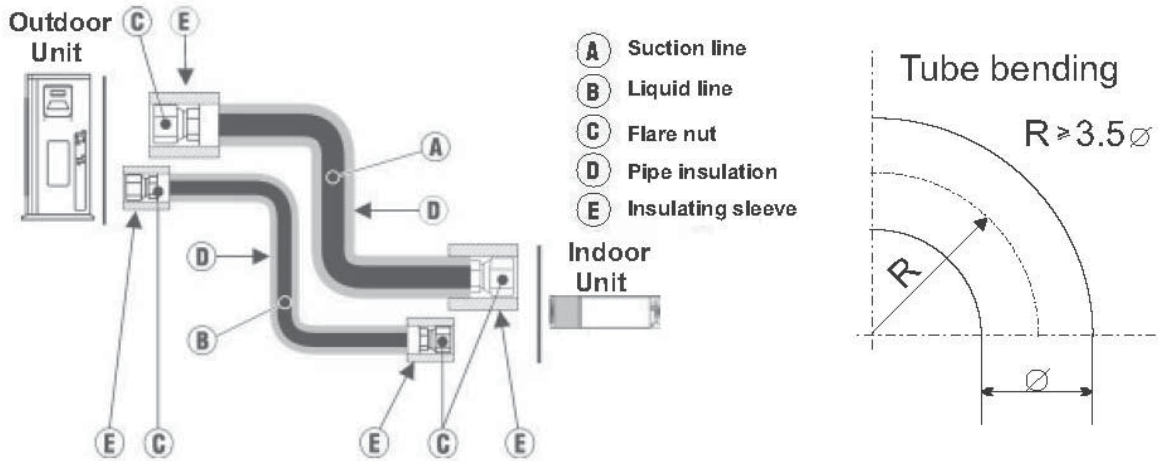

TUBE (Inch)	1/4"	3/8"	1/2"	5/8"	3/4"
TORQUE (Nm)					
Flare Nuts	11-13	40-45	60-65	70-75	80-85
Valve Cap	13-20	13-20	18-25	18-25	40-50
Service Port Cap	11-13	11-13	11-13	11-13	11-13

1. Valve Protection Cap-end
2. Refrigerant Valve Port (use Allen wrench to open/close)
3. Valve Protection Cap
4. Refrigerant Valve
5. Service Port Cap
6. Flare Nut
7. Unit Back Side
8. Copper Tube

When the outdoor unit is installed above the indoor unit an oil trap is required every 5m along the suction line at the lowest point of the riser. In case the indoor unit is installed above the outdoor, no trap is required.

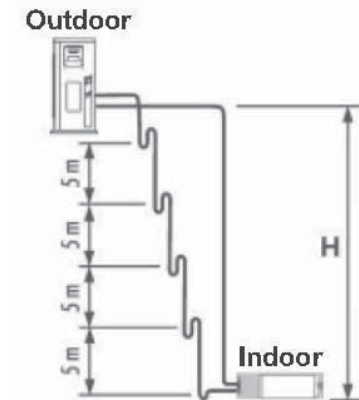

12. CONTROL SYSTEM DELTA18-21-24 TYPE UNITS

12.1 Electronic Control

12.1.1 Introduction

The electronic control information is designed for service applications, and is common to the following groups of air-conditioners:

- **ST/ RC group** -Cooling only / cooling and heating by heat pump.
- **SH group** -Cooling and heating by heat pump and supplementary heater.
- **RH group** -Cooling, heating by heaters only.

12.1.2 Jumpers Settings

GROUP	J6 Setting	J2 Setting
ST / RC	Open	Open
SH	Closed	Open
RH	Closed	Closed

12.2 Legend

AC	- Alternate Current
A/C	- Air-Conditioner
ANY	- ON or OFF status
CLOCK	- ON/OFF Operation Input, (dry contact)
COMP	- Compressor
CPU	- Central Processing Unit
ELUM	- Extended Louver Upward Movement (Software Jumper)
E ² PROM, EEPROM	- Erase Enable Programmable Read Only Memory
HE	- Heating Element
HPC	- High Pressure Control
H/W	- Hardware
ICP	- Indoor Condensation Pump
ICT	- Indoor Coil Temperature (RT2) sensor
IF, IFAN	- Indoor Fan
IR	- Infra Red
LEVEL1	- Normal Water Level
LEVEL2/3	- Medium/High Water Level
LEVEL4	- Overflow Level
Max	- Maximum
Min	- Minimum
min	- Minute (time)
NA	- Not Applicable
OCP	- Outdoor Condensation Pump
OCT	- Outdoor Coil Temperature (RT3) sensor
OF, OFAN	- Outdoor Fan
OPER	- Operate
Para.	- Paragraph
RAT	- Return Air Temperature (RT1) sensor
RC	- Reverse Cycle (Heat Pump)
R/C	- Remote Control
RCT	- Remote Control Temperature
RH	- Resistance Heater
RT	- Room Temperature (i.e. RCT in IFEEL mode, RAT otherwise)
RV	- Reversing Valve
SB, STBY	- Stand-By
sec	- Second (time)
Sect	- Section
SH	- Supplementary Heater
SPT	- Set Point Temperature
ST	- Standard (a Model with Cooling Only)
S/W	- Software
TEMP	- Temperature
W/O	- Without
WVL	- Water Valve
ΔT	- The difference between SPT and RT. in Heat Mode: $\Delta T = SPT - RT$ in Cool/Dry/Fan Mode: $\Delta T = RT - SPT$

12.3 Main PCB Controller

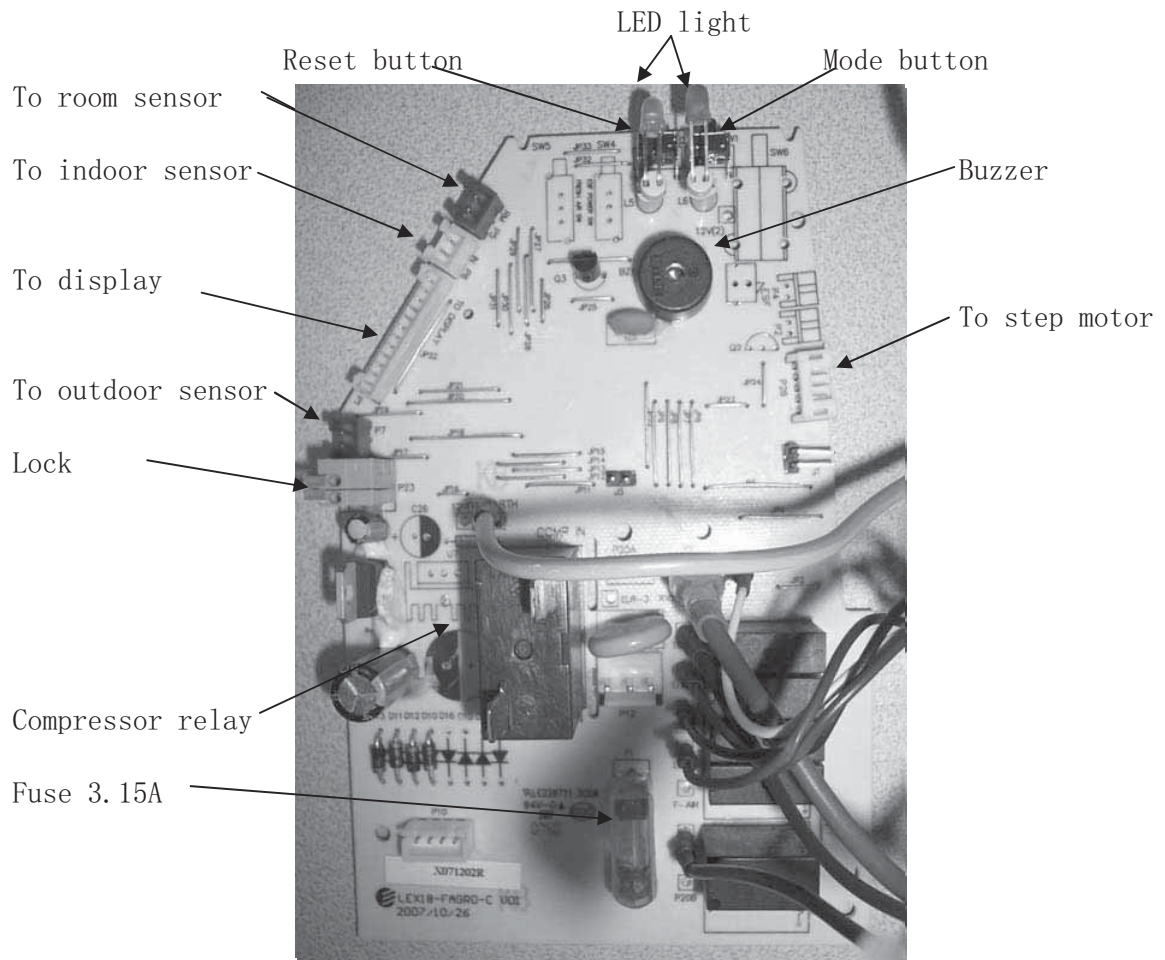

12.3.1 LED Display DELTA

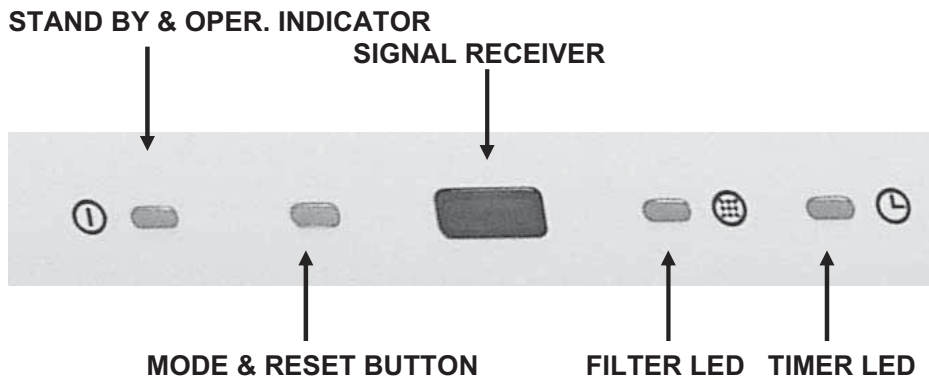

12.4 General functions

12.4.1 COMP operation

For each Mode including POWER OFF & SB, a Min time delay of 3 min before COMP restarting, excluding DEICING Mode

The Min operation time of COMP under different operating conditions is

Operation Mode	Min operation time of COMP
Heat, Cool or Auto Modes	3 min.
Fan, Dry, Overflow, Protection modes, or mode change	ignored

12.4.2 IFAN operation

- Min time interval between IFAN speed change in AUTOFAN Mode, is 30 sec.
- Min time interval between IFAN speed change in H/M/L Mode is 1 sec.
- IFAN speed in Heat/Cool Autofan Mode is determined according to the following table:

ΔT	IFAN Speed
$\Delta T \geq 2$	HIGH
$2 \geq \Delta T \geq 1$	MED
$1 \geq \Delta T$	LOW

where in Heat Mode: $\Delta T = SPT - RT$
 in Cool Mode: $\Delta T = RT - SPT$

Note:

- In Heat Mode, the rules in section 4.0.3 have the higher priority.
- The table above can be represent by a hysteresis curve which will minimize the switching of the IFAN relay and will minimize the change in IFAN speed:

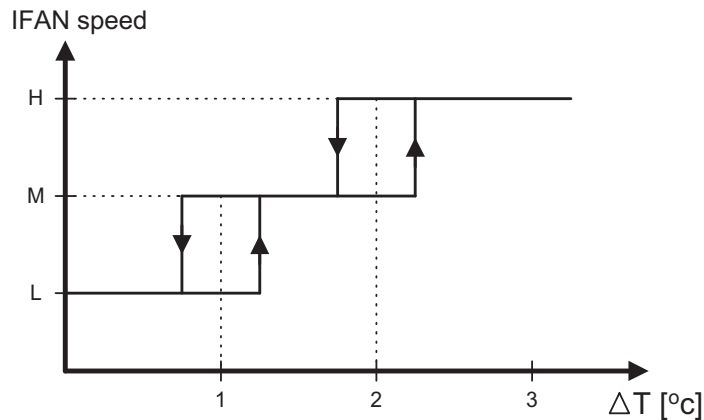

12.4.3 OFAN operation

- Min time interval between OFAN ON/OFF state change is 30 sec.
- In general, OFAN starts together with COMP.

12.4.4 HE operation

- Minimum Heaters ON or OFF time is 30 sec.
- Heaters can be activated only if IFAN is on.

12.4.5 Protections

- High pressure protection is applicable to all operating modes.
- Deicing control is valid in Heat and Auto Heat Mode only.
- Defrosting control is valid in Dry, Cool, Heat and Auto Modes.
- No reset after protection modes.

12.4.6 Thermistors operation

- Return air Temp. is detected by RAT (RT1) in normal Mode, or by RCT (R/C sensor) in I-FEEL Mode.
- Indoor Coil Temp. is detected by ICT (RT2).

12.4.6.1 Definition of thermistor faults:

- a. Thermistor is disconnected -
The thermistor reading is below -30°C .
- b. Thermistor is shorted -
The thermistor reading is over 75°C .
- c. Thermistor Temp reading doesn't change (irrelevant for RT1) -
 - (i) This test is performed only once after a unit is switched from OFF/STBY to operation. At the first occurrence of 10 min continuous COMP operation, the current ICT & OCT are compared with those when the COMP was switched from OFF to ON 10 min before. If the ΔT is less than 3°C , the thermistor is regarded as defective.
 - (ii) The ICT and OCT no-change error can be disabled together by connecting a 4.7 kohm resistor (5%) to the OCT connector. These resistors are equivalent to a thermistor at $43\pm 1^{\circ}\text{C}$ and $48\pm 1^{\circ}\text{C}$ respectively.
 - (iii) Connecting a 4.7k resistor to the ICT connector will disable the ICT no-change error only.

12.4.6.2 Cases for disabling thermistor short/disconnected detection

- i. The detection of thermistor faults (a) and (b) above, are disabled when Deicer Protection is started. The detection will be enabled again only after (1) the deicing is completed, and (2) COMP has been restarted and operated for 30 sec.
- ii. When all the following conditions are fulfilled:
 - a. 4.7K Ohm resistor is connected on the OCT
 - b. IFAN is OFF
 - c. Compressor is ON
 - d. ICT < -30 (disconnected)This condition come to detect and prevent IFAN operation in Deicer in multi spilt units.

12.4.6.3 Handling the thermistor faults in a COMP unit

- i. ICT/OCT thermistor is disconnected or shorted -
The invalid thermistor temperature is replaced by 43°C, so that the unit can continue the normal operation. All protections related to that faulty thermistor will be disabled. For example, in case of any ICT fault, the ICT high pressure protection in Heat Mode and ICT defrost protection in Cool Mode will not operate anymore. The same is also applied to the OCT fault.
- ii. RAT thermistor is disconnected or shorted –
The RAT will be derived from the ICT by using the equations :
Heat Mode: $RAT = ICT / 2.3$
Cool Mode $RAT = ICT * 4$

Notes:

- In case of any thermistor failure, the STBY LED will be blinking until the fault condition is corrected.
- User can use the system diagnostics function to find out the nature of the thermistor faults.

- i. RAT thermistor is disconnected or shorted –
System will operate continuously in the last IFAN & WVW status when turned ON.

Notes:

- As in the COMP unit, the STBY LED will be blinking to indicate a thermistor fault. And, the user can use the system diagnostics function to find out the nature of the fault.

12.5 Cooling Mode - General

- 1) Room Temperature, RT, is detected by
 - RAT in normal operation, or
 - RCT (R/C sensor) in I-FEEL mode.
- 2) The resolution of RT is 1°C.
 - RT is activating COMP/WVL if (RT > SPT), and
 - RT is stopping COMP/WVL if (RT ≤ SPT).
- 3) Indoor Coil Temp is detected by ICT (RT2).
- 4) Outdoor Coil Temp is detected by OCT (RT3).
- 5) A WVL-RC/SH will work in Cooling Mode when
 - ICT < 16°C in general (see Sect 2.2.2 for details), and
 - Unit is not operating in Fan Mode.
- 6) OFAN OPERATIONS
 - OFAN starts together with COMP in general.

12.5.1 Cooling

Mode: Cool, Auto (at Cooling)
 Temp: Selected desired temperature.
 Fan: HIGH, MED, LOW
 Timer: Any
 I Feel: On or Off

Control function

Maintains room temp at desired level by comparing RT and SPT.

(RT - SPT) [°c]

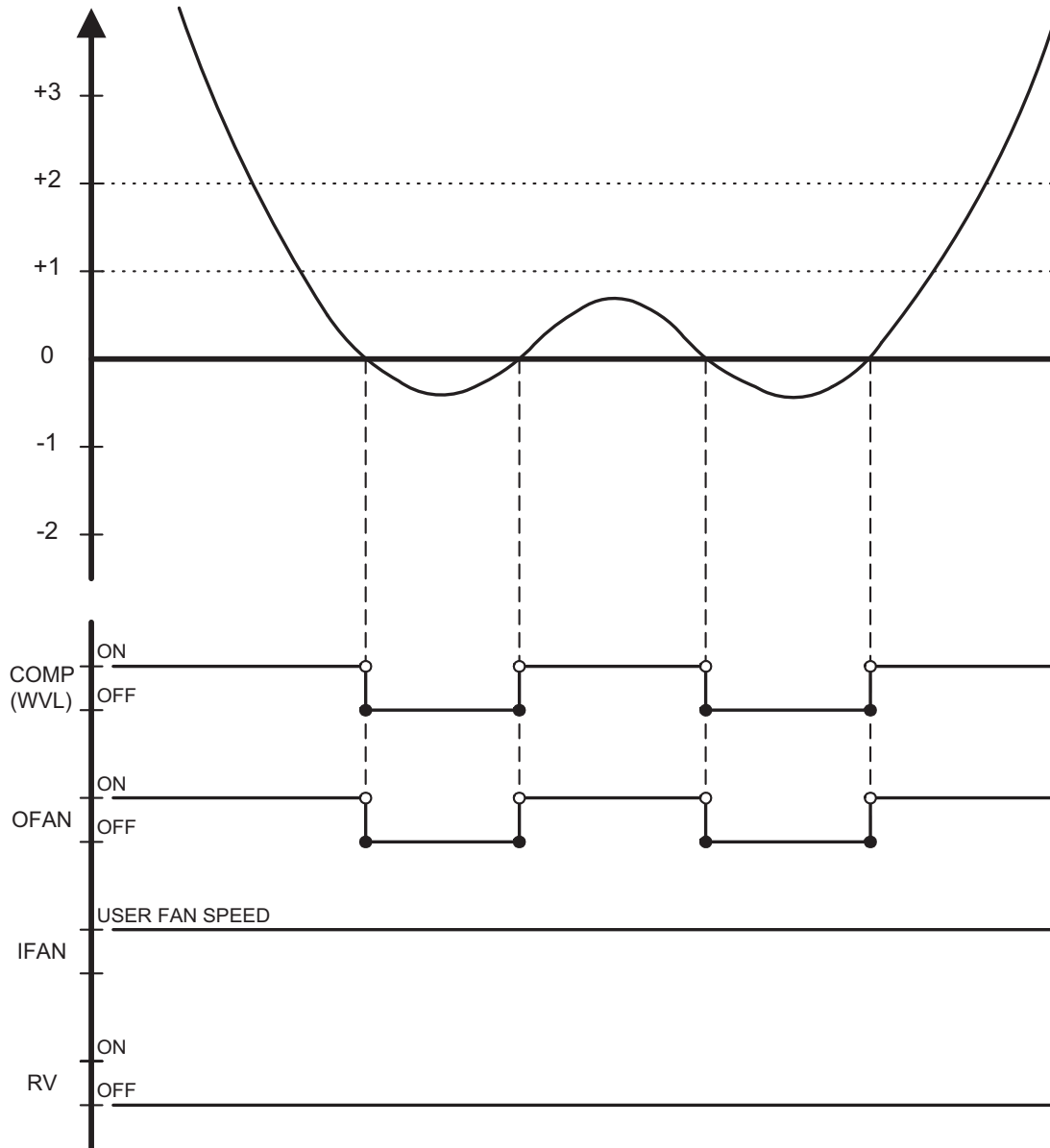

Note:

- 1) IFAN is always running at High, Medium or Low speed selected by user.
- 2) In IFEEL mode, the Room Temperature (RT) is the RCT from a R/C. Otherwise, the RT is the RAT from the Room Thermistor.

12.5.2 Cooling with Autofan

- Mode: Cool, Auto (at cooling)
- Temp: Selected desired temperature
- Fan: Auto
- Timer: Any
- I Feel: On or Off

Control function

Maintains room temp at desired level and controls the IFAN speed for optimal comfort.

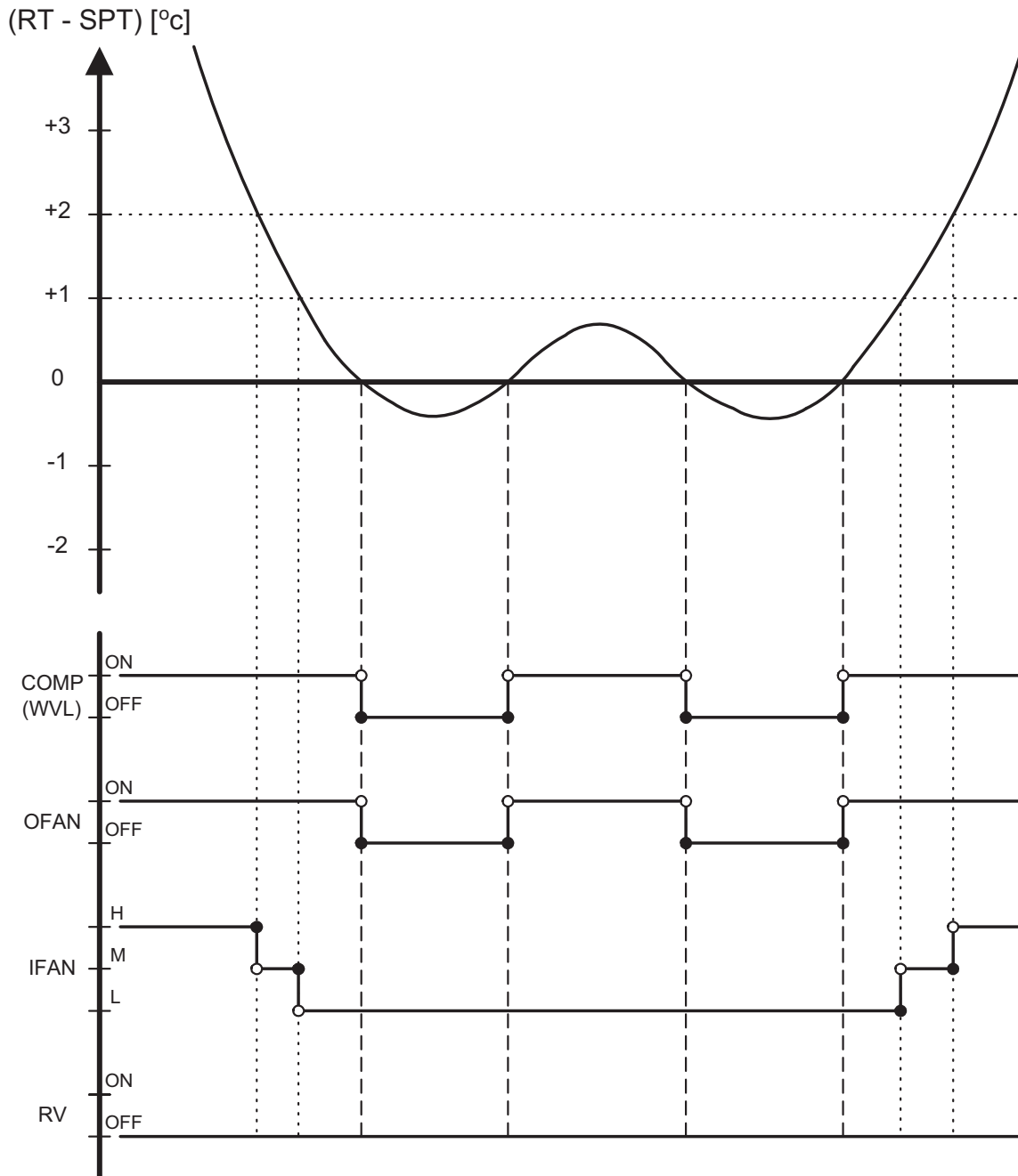

12.6 Heating Mode

12.6.1 Heating Mode - General

- In heating Mode, temp. compensation schedule will be activated for wall mounted units.

SPT [°c]	Add to SPT	
	I-FEEL ON	I-FEEL OFF
$18 \leq SPT \leq 27$	0 °c	+2 °c
$27 < SPT \leq 30$	0 °c	+3 °c

Notes :

- No compensation will be activated in Forced operation modes

12.6.2 IF operating rules

- As a general rule for **RC and SH groups**, when **COMP is ON**, excluding protection modes, IFAN will be switched ON if
- ICT > 35°C or
at the IFTC 30 sec after the COMP is switched ON. In this case, the IFAN will be started at low speed.

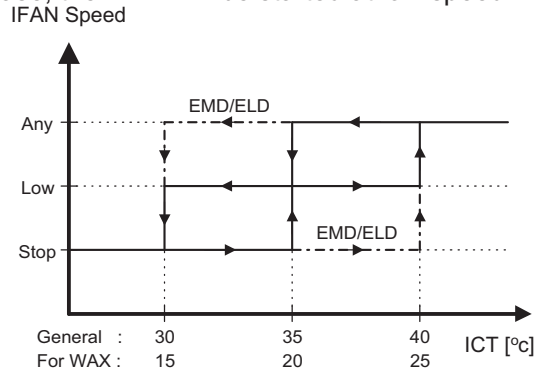

Notes :

- In **SH or RC group**, if HE is set to OFF due to low ICT, IFAN will be switched to LOW and will be turned OFF after 30 sec.
 - An exception to this rule (4.0.3.a) is the Back-up mode for SH.
- In **RC and SH groups**, whenever **COMP & HE are both OFF**, excluding protection modes, IFAN operation will be according to the following:

In **other models** IFAN will operate in low speed for 30 sec and then stop. If COMP is OFF for more than 3 minutes and IFEEL Mode is inactive, IFAN will operate in low speed according to the following graph:

IFAN (Low Speed)

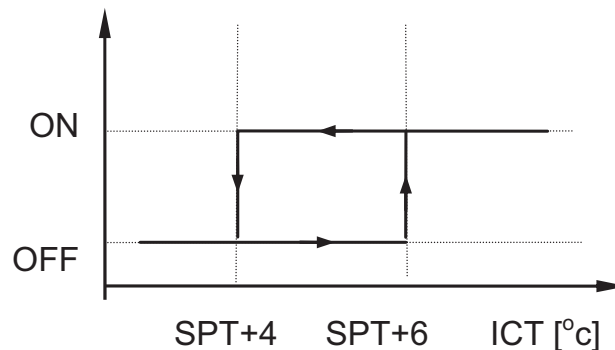

12.6.3 HE operation

- For **all Groups**, HE can be ON only when IFAN is ON.
- For **all Groups**, HE switches to OFF when $ICT > 50\text{ }^{\circ}\text{C}$, and is activated again when $ICT \leq 45\text{ }^{\circ}\text{C}$.
- In **SH or RC group**, HE operation is limited by the following graph:

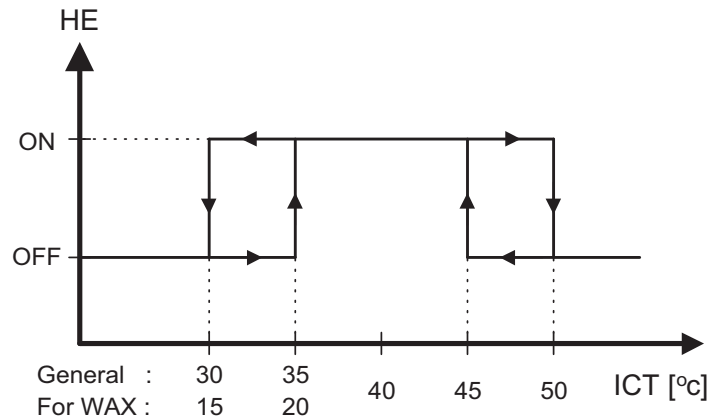

- Back-up mode for **SH group**

After COMP has been working for 5 minutes, HE & IFAN are activated even if the ICT is still below $35\text{ }^{\circ}\text{C}$. This situation is called Back-up Mode. Both HE & IFAN will work in Back-up Mode until the ICT reaches $35\text{ }^{\circ}\text{C}$. Then, the operation goes on in the usual mode .

12.6.4 Heating, RC or SH Group

Mode: Heat, Auto (at heating)
 Temp: Selected desired temperature
 Fan: HIGH, MED, LOW
 Timer: Any
 I Feel: On or Off

Control function

Maintains room temp. at desired level by comparing RAT or RCT to SPT.

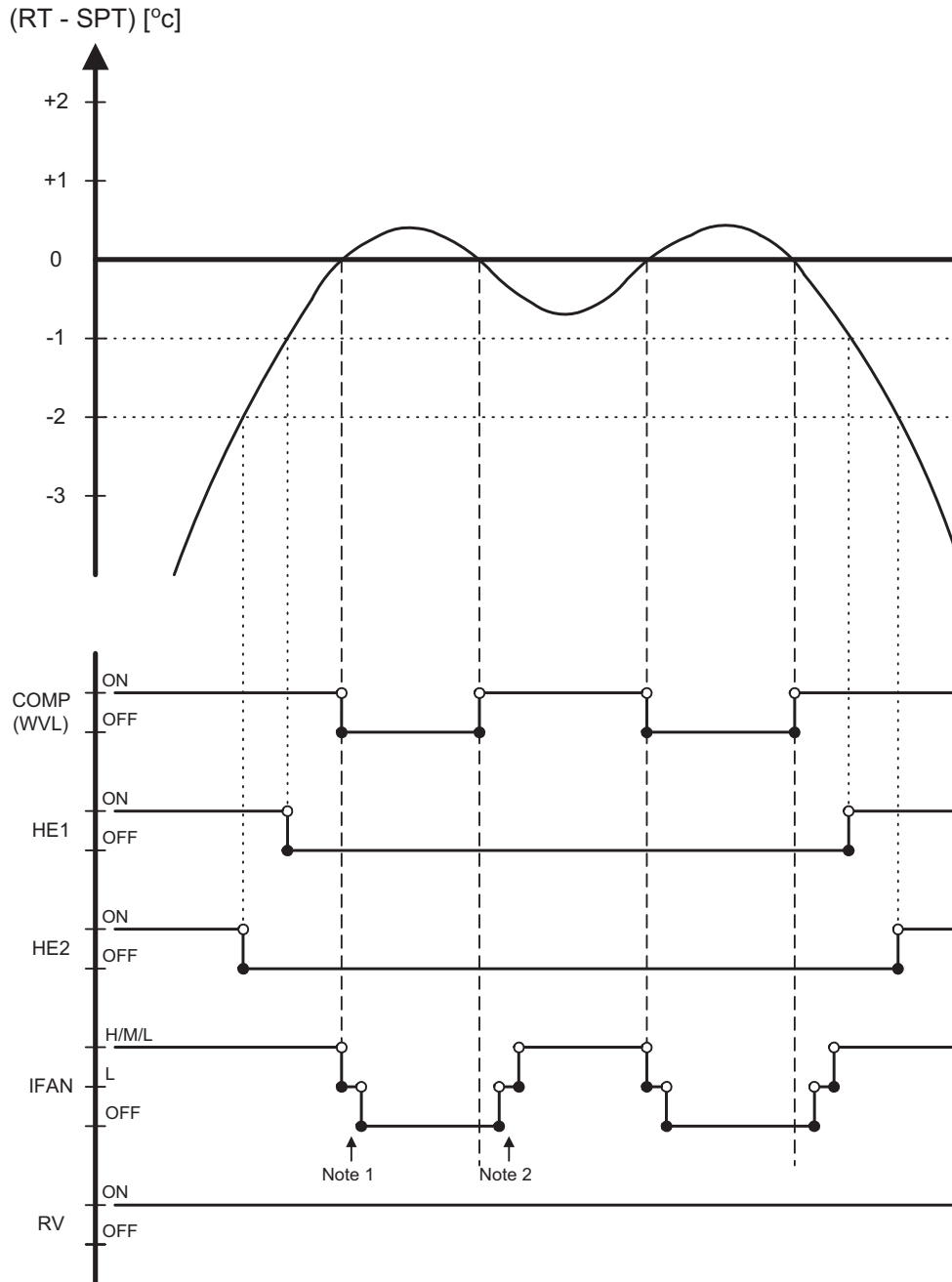

12.6.5 Heating, RC or SH Group with Autofan

Mode: Heat, Auto (at heating)
 Temp: Selected desired temperature
 Fan: Auto
 Timer: Any
 I Feel: On or Off

Control function

Maintains room temp at desired level by controlling COMP, IFAN and OFAN.

(RT - SPT) [°C]

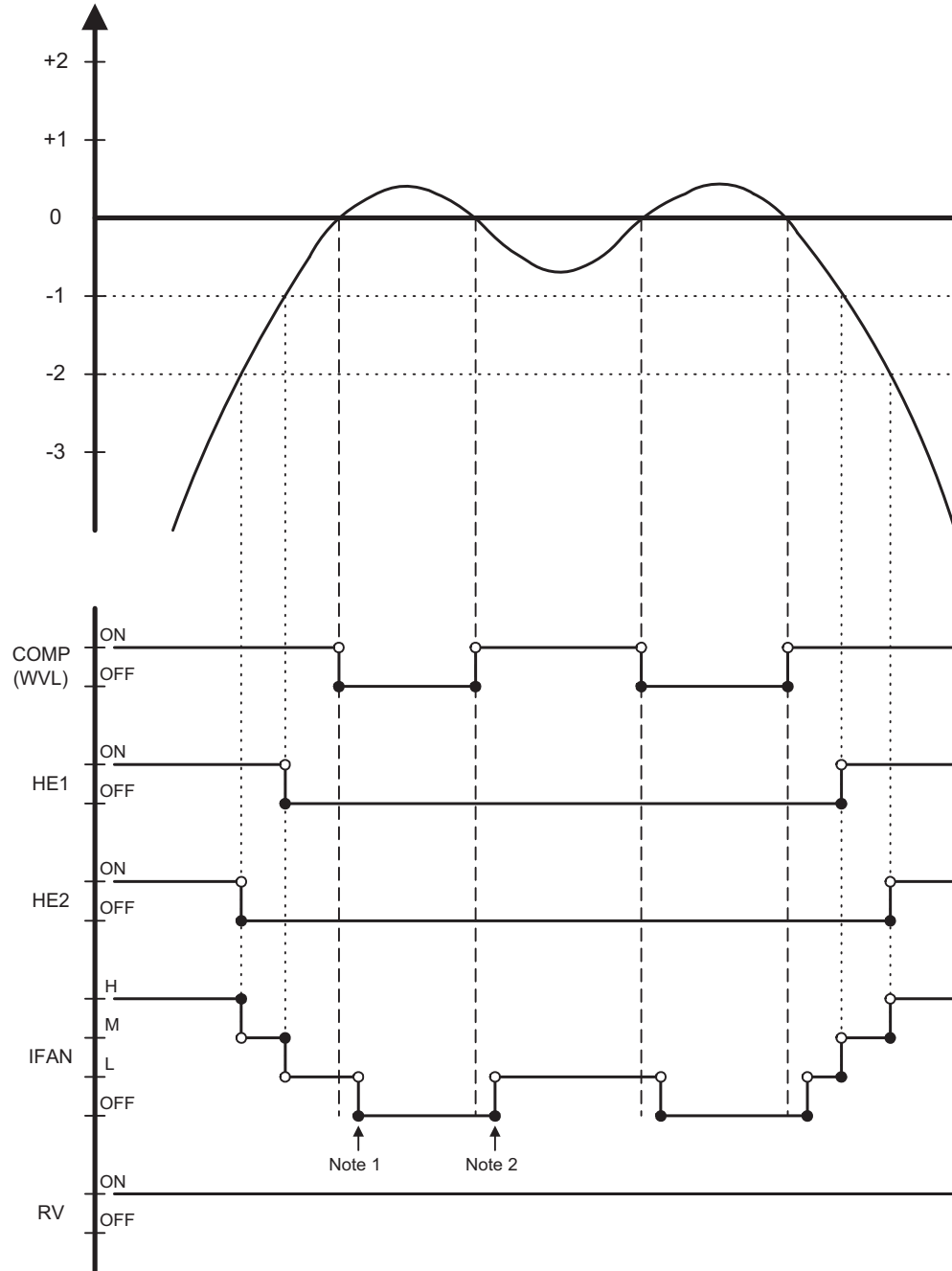

12.6.6 OFAN operation is controlled by the graph below when

1. ($RAT \geq SPT - 2^{\circ}C$), AND
2. ($ICT \geq 45^{\circ}C$), AND
3. (COMP is ON)

Otherwise, OFAN runs together with COMP.

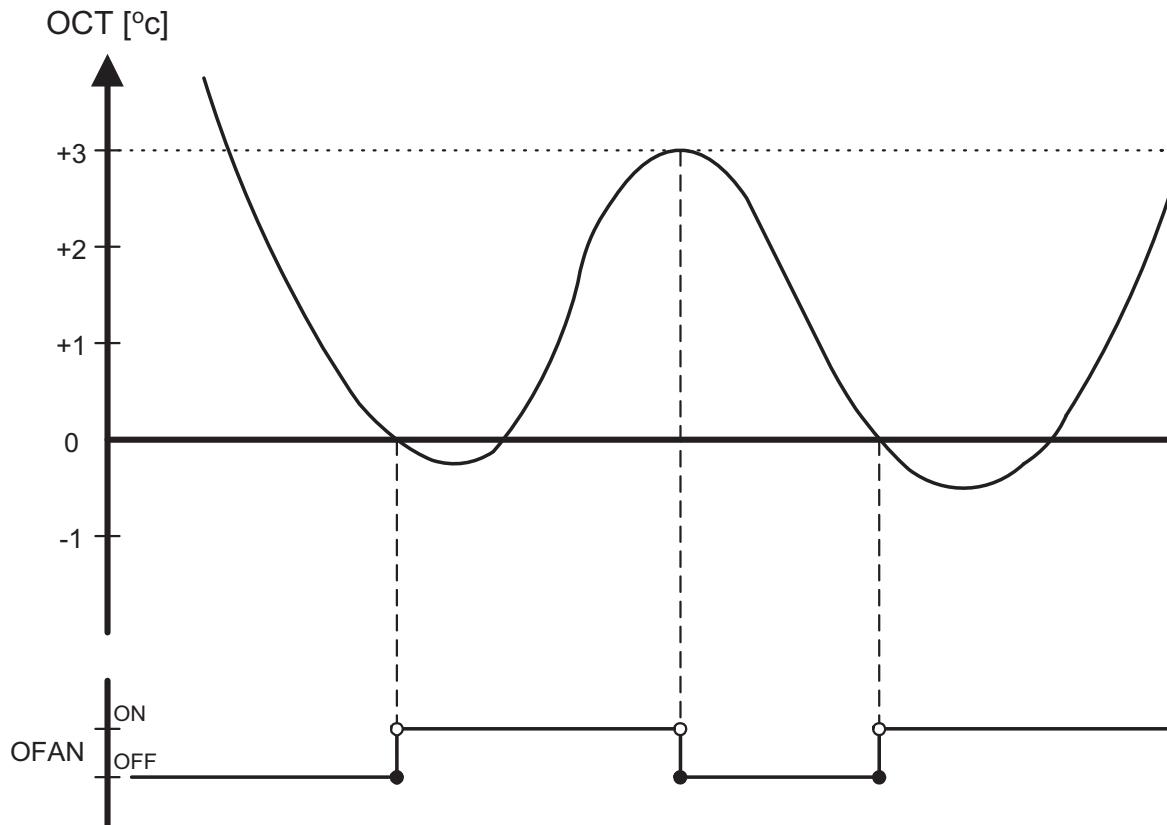

12.7 Automatic Cooling or Heating

12.7.1 Automatic Cooling or Heating - General

- Switching-temperature between Cooling and Heating is $SPT \pm 3^{\circ}\text{C}$.
- Autofan in Automatic Cooling and Heating Mode will activate “Cooling with Autofan Mode” and “Heating with Autofan Mode” respectively.
- When the Auto Mode is started with $SPT \pm 0^{\circ}\text{C}$, the unit will not select Auto Heat or Auto Cool mode immediately. Instead, the unit will be in a temporary Fan Mode with IFAN operating at low speed. The proper Auto Heat mode or Auto Cool will be started whenever the RT reaches $SPT-1^{\circ}\text{C}$ or $SPT+1^{\circ}\text{C}$ respectively.
- For RC & SH units, Mode change between Auto Heat & Auto Cool Modes is possible only after the COMP has been OFF during the last T minutes.

Mode Change	time, T
Auto Cool to Auto Heat	3 min
Auto Heat to Auto Cool	4 min

- When unit is changed from Cool/Dry mode to Auto Mode, the unit will continue to operate at (Auto) Cool Mode until the conditions for switching from Auto Cool to Auto Heat are satisfied. Similarly, when unit is changed from Heat Mode to Auto Mode, the unit will continue to operate at (Auto) Heat Mode until the conditions for switching from Auto Heat to Auto Cool are satisfied.

12.7.2 Auto Cooling or Heating, RC or SH Groups

Mode: Auto
 Temp: Selected desired temperature
 Fan: Any
 Timer: Any
 I Feel: On or Off

Control function

Maintains room temp at desired level by selecting between cooling and heating modes.

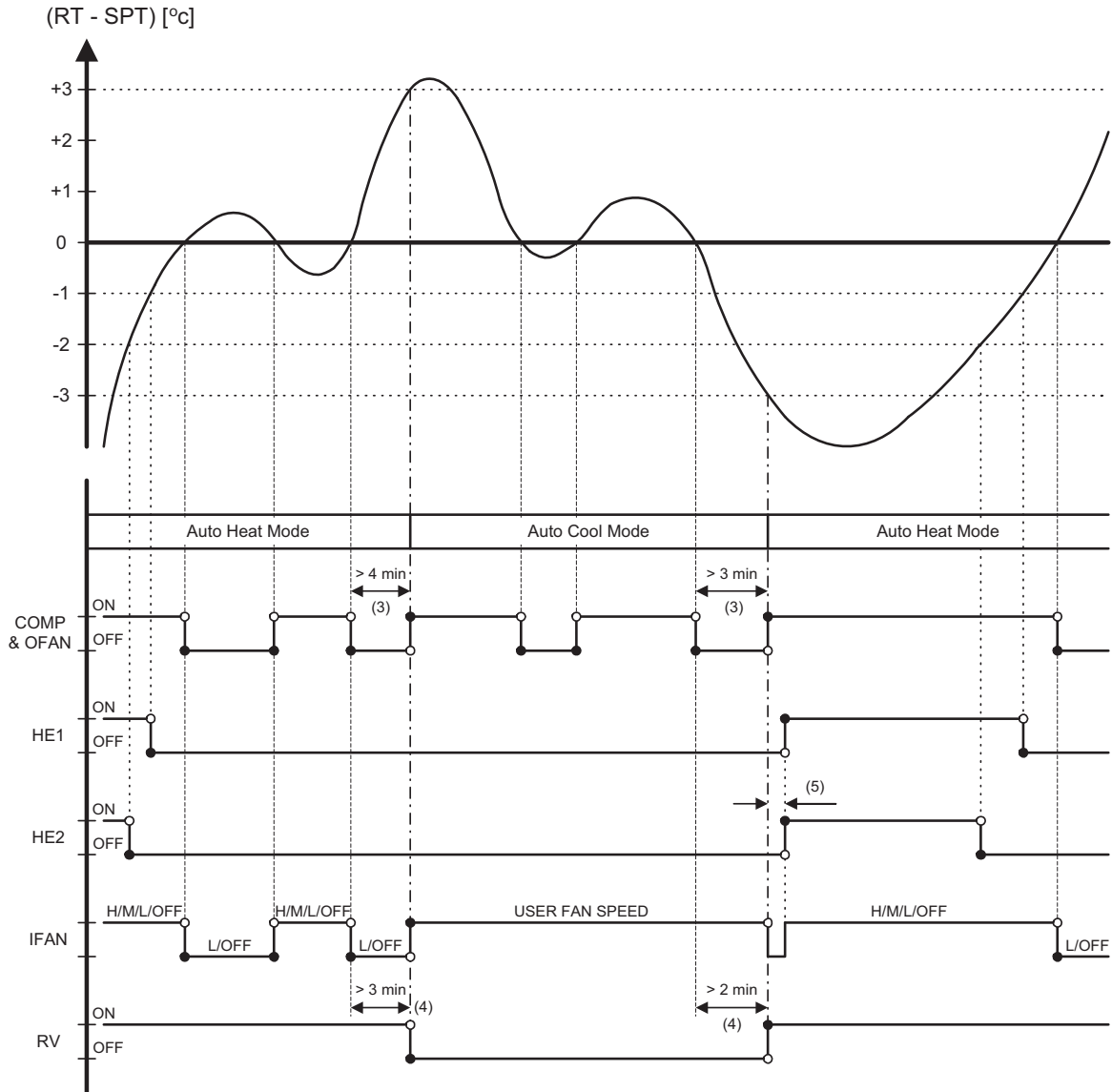

12.8 Dry Mode

12.8.1 Dry, ST or RC group

Mode: Dry
 Temp: Selected desired temp
 Fan: Low (automatically selected by software)
 Timer: Any
 I FEEL: Any

Control function

Reduce room humidity with minimum temp. fluctuations by operating in Cool Mode with low speed IFAN.

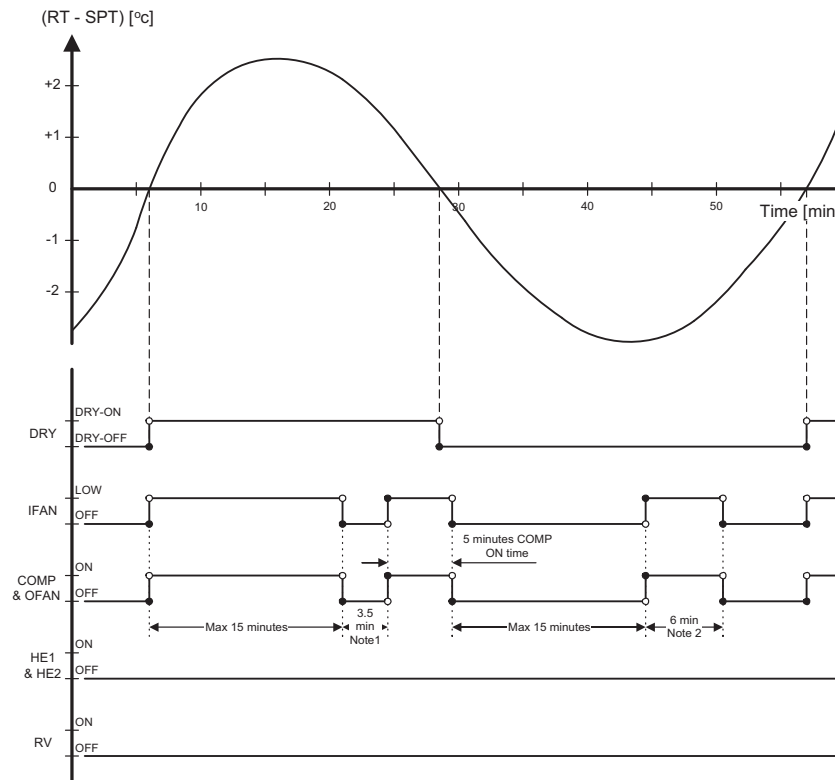

Notes :

- When Dry is ON, the COMP is forced OFF for 3.5 min (longer than the 3 min Min COMP-Off time) after every 15 min of continuous COMP operation.
- When Dry is OFF, the COMP is forced ON for 6 min (longer than the 3 min Min COMP-On time) after every 15 min of continuous COMP OFF time.
- When Dry is changed from ON to OFF or vice versa, the limits mentioned in (1) & (2) are ignored. The COMP operation is only controlled by the 3 min Min OFF time and 1 min Min ON time.
- In Dry Mode, IFAN is LOW when COMP is ON, and is OFF when COMP is OFF.

12.9 Protection

12.9.1 Cooling Mode Protections

Indoor Coil Defrost

Mode: Cooling, Dry, Auto

Temp: Selected desired temp.

Fan: Any

Timer: Any

I Feel: On or Off

Control Function

Protect the indoor coil from ice formation at low ambient temperature.

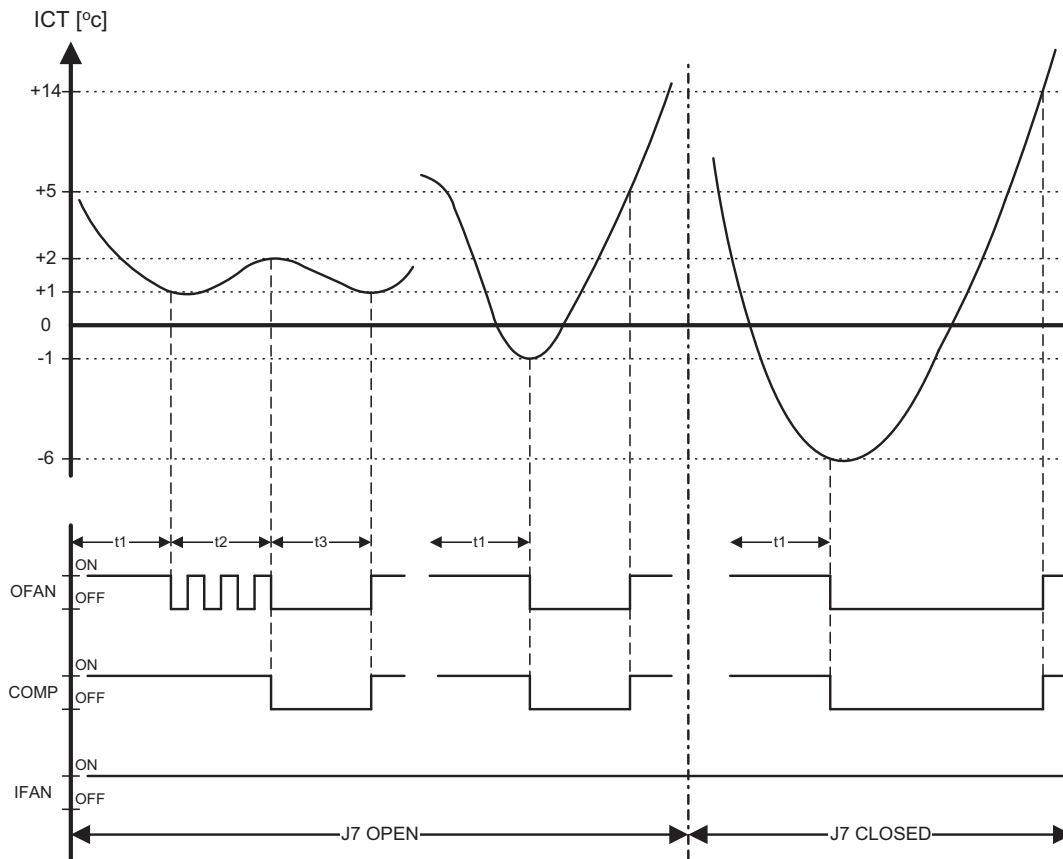

t1 = 5 min minimum for each COMP starting

t2 = OFAN cycling (alternate between ON and OFF every 30 sec) for 20 min maximum

t3 = COMP and OFAN stop for 10 min minimum

Notes:

- When J7 is closed (connected), OFAN cycling is cancelled and the set temperature for COMP & OFAN cut-out and cut-in are changed. COMP & OFAN are forced OFF when $ICT \leq -6^{\circ}\text{C}$, and are kept OFF until $ICT > 14^{\circ}\text{C}$.
- For WAX model, the defrost processes is simpler. When J7 is open, COMP & OFAN are forced OFF when $ICT \leq -1^{\circ}\text{C}$, and are kept OFF until $ICT > 5^{\circ}\text{C}$. When J7 is closed, the WAX defrosting process is the same as that of the other models (R.H.S. of the graph above). In both cases, the ICT checking in t2 and t3 are not applied.

12.3.2 High Pressure Protection

Mode: (Auto) Cooling or Dry
 Temp: Selected desired temp.
 Fan: Any
 Timer: Any
 I Feel: On or Off

Control Function

To protect the COMP from the high pressure built-up in the outdoor coil during normal cooling operation, by switching OFF the IFAN and COMP.

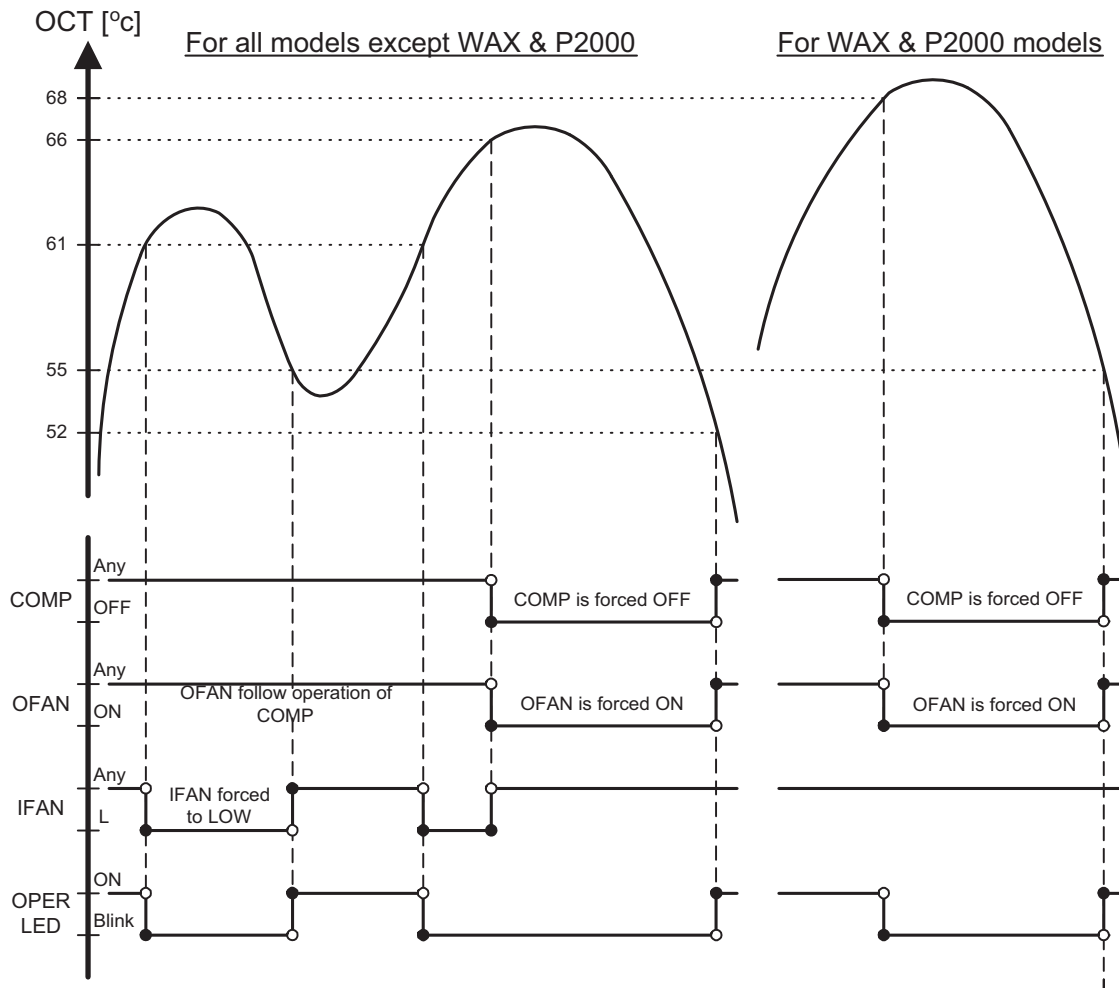

Note:

- The ICT is also monitored during Cool and Dry mode, in case the RV control circuit is faulty. Whenever ICT reaches 70°C, which indicates a high pressure in the indoor coil, the COMP will be forced off automatically. The COMP can be turned on again only after the ICT is under 70°C again and after the 3 min COMP ON delay time. The OPER LED will not blink in this case.

12.9.3 Heating Mode Protections

Outdoor coil Deicing (excluding RH Group)

Mode: Heating, Auto (at heating)

Temp: Selected desired Temp

Fan: Any

Timer: Any

I FEEL: Any

Control function

Protects the Outdoor coil from ice formation by controlling COMP & RV operation.

Scope

This new deicer is designed to operate at extreme temp conditions. The deicing cycle could be triggered from:

1. OCT temp and time between two consecutive deicing cycles.
2. Detection of ice forming by change of the OCT temp.

Both algorithms adjust the time between deicing cycles to optimize the A/C performance. The algorithm will automatically increase the time between deicing cycles and reduce the deicing cycle as needed.

The algorithm uses EEPROM data to operate.

Deicing procedure

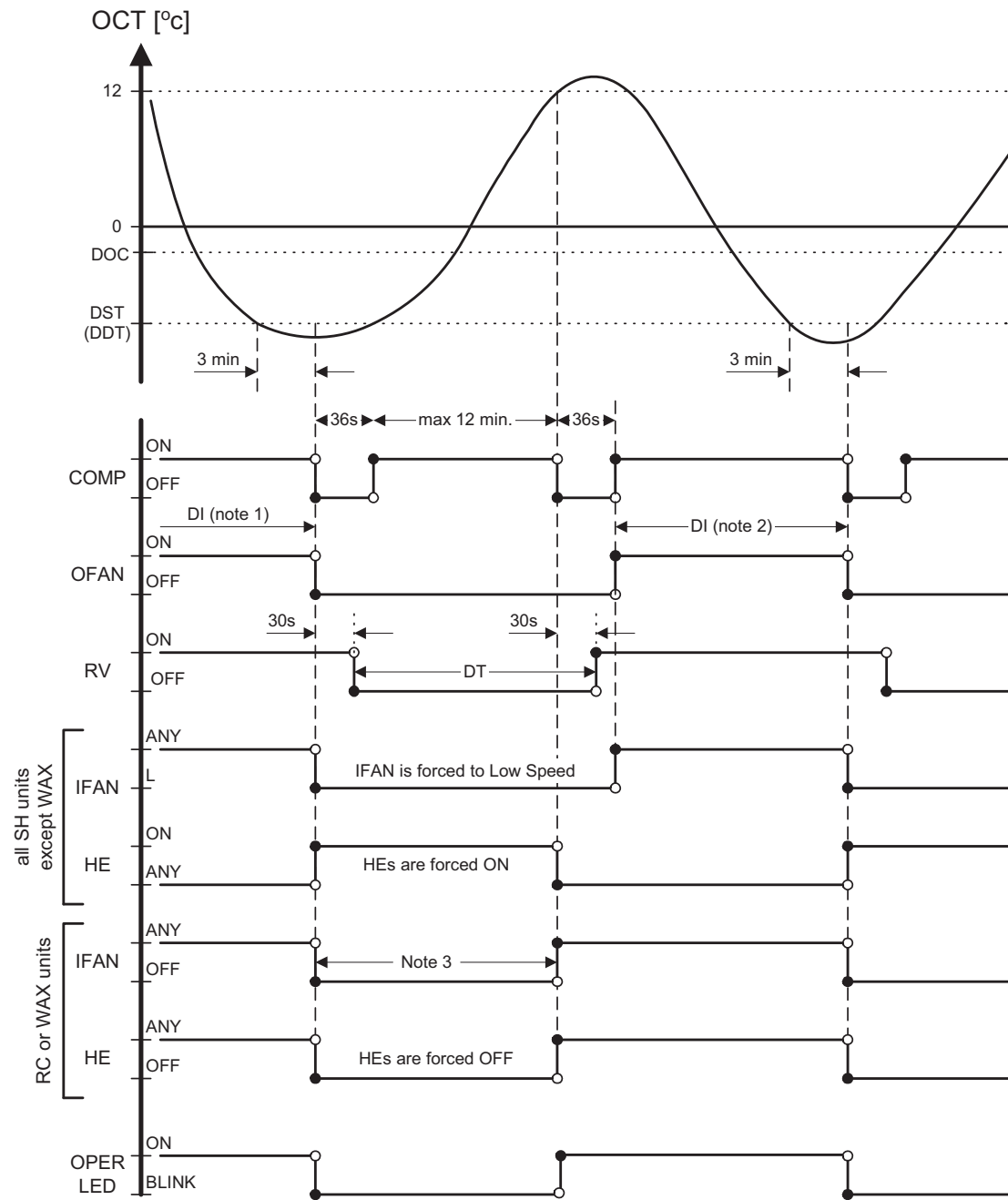

Notes :

- At the first COMP activation after SB or OFF, if (OCT < 0°C), then DI = 10 min, else DI = 40 min.
- In the following Deicing cycles, the time interval between two Deicing cycles activation is between 30 to 80 min (refer to the flow chart).
- For RC group, HEs are forced OFF. IFAN operation is as in Heat Mode, Sect 4.0.3.a, i.e. IFAN will be set to OFF when ICT < 30°C. For WAX, the IFAN is simply forced OFF.
- For SH group, HEs are forced ON and IFAN is forced to operate in Low speed, regardless of the ICT and difference between RAT & SPT.

12.9.4 High pressure protection (excluding RH Group)

Mode: (Auto) Heating
 Fan: Any
 Timer: Any
 I Feel: On or Off

Control Function

Protect the Compressor from high pressure by switching OFF the OFAN and COMP.

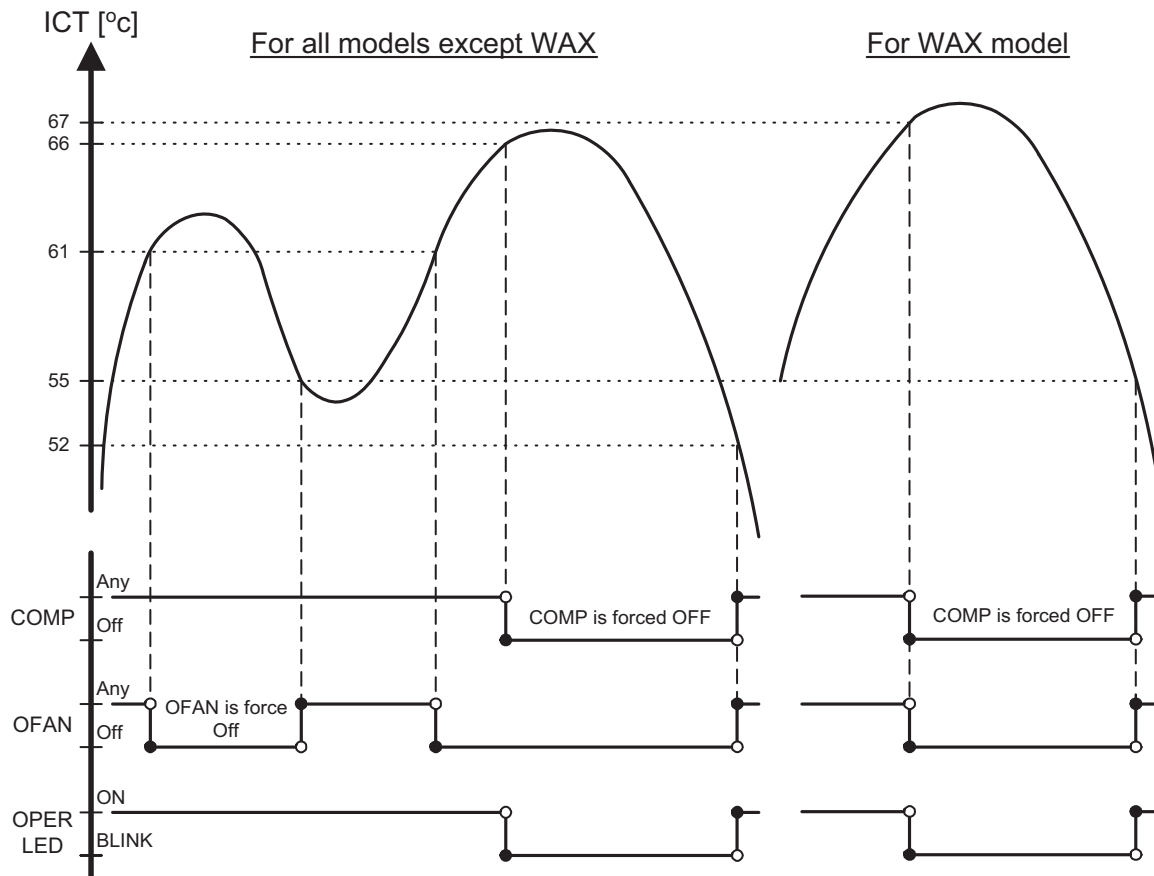

Notes:

- IFAN, HE1 and HE2 will be activated according to the relevant Heating Mode Sect.
- In case of any malfunction in the relay control circuit, the OCT is also monitored during heating mode. Whenever OCT reaches 70°C, which indicates a high pressure in the outdoor coil, the COMP will be forced off automatically. The COMP can be turned on again only after the 3 min COMP ON delay and the OCT is under 70°C. The OPER LED will not blink in this case.

12.10 Timer

Mode: Any
Temp. Selected desired temp
Fan: Any
Timer: Timer On, Timer Off
I Feel: On or Off

Control function

- Starts or stops the unit operation after pre-set time. If RC-1 is used, the timer setting will be (0.5 - 24 Hr) from the moment the timer is set. The minimum resolution is 30 minutes.
If RC-2 or later version of remote controls is used, the timer setting will be (0:00 - 23:50) real time with 10 minutes resolution.
- After power failure, all pre-set timers are cleared. The system is forced to STBY mode and the Timer LED indicator is blinked to indicate the situation. The LED keeps blinking until the timer settings can be reloaded from a R/C message.
Note: If all timers are inactive, the system will not be forced OFF after the power failure. The last OPER/STBY status will be loaded from the EEP instead.
- When the A/C receives any valid message from a R/C, the current ON/OFF timer settings will be replaced by the new timer settings in the R/C message.
Note: The following timer related operations will not affect the A/C operating mode (Heat/Cool/Auto/Dry/Fan) setting.
 - Set ON/OFF timer
 - Clear ON/OFF timer
 - R/C ON Timer is time-up
 - R/C OFF Timer is time-up

E.g. When a STBY A/C unit (with Cool Mode setting in its EEP) is turned on by the ON-TIMER of a R/C with heat mode setting, the A/C will start in Cool Mode.

12.11 Forced Operation

Forced operation allows units to start, stop and operate in Cooling or Heating in pre-set temperature according to the following table:

Forced operation mode	Pre-set Temp for : WMF, WMN, WNG models
Cooling	22°C
Heating	28°C

Note:

- While under the forced operation, the temperature compensation schedule.
- The forced operation is activated when the mode button on the Display Board is used to switch the unit to Cool or Heat mode.
- The IFAN is always set to Autofan Speed in forced operation.

12.12 Sleep Mode

- Mode: Any
- Temp: Set – desired temperature selected
- Fan: Any
- Timer: Interact with Sleep Timer as described in sect 12.2
- I Feel: On or Off

The Sleep mode is activated by using the sleep button on the R/C. In Sleep Mode, the unit will automatically adjust the SPT to turn up/down the room temperature (RT) gradually to provide maximum comfort to the user in sleep.

Sleep is treated as TIMER function. Therefore, the TIMER LED is activated similar to TIMER function.

12.12.1 Adjustment in Sleep Mode

1. in cool, auto cool or dry modes, the SPT adjustment is positive (from 0 to +3°C).
2. In heat or auto heat modes, the SPT adjustment is negative (from 0 to -3°C).
3. In other modes, there is no SPT adjustment.
4. The SPT adjustment is cancelled when the Sleep mode is cancelled.

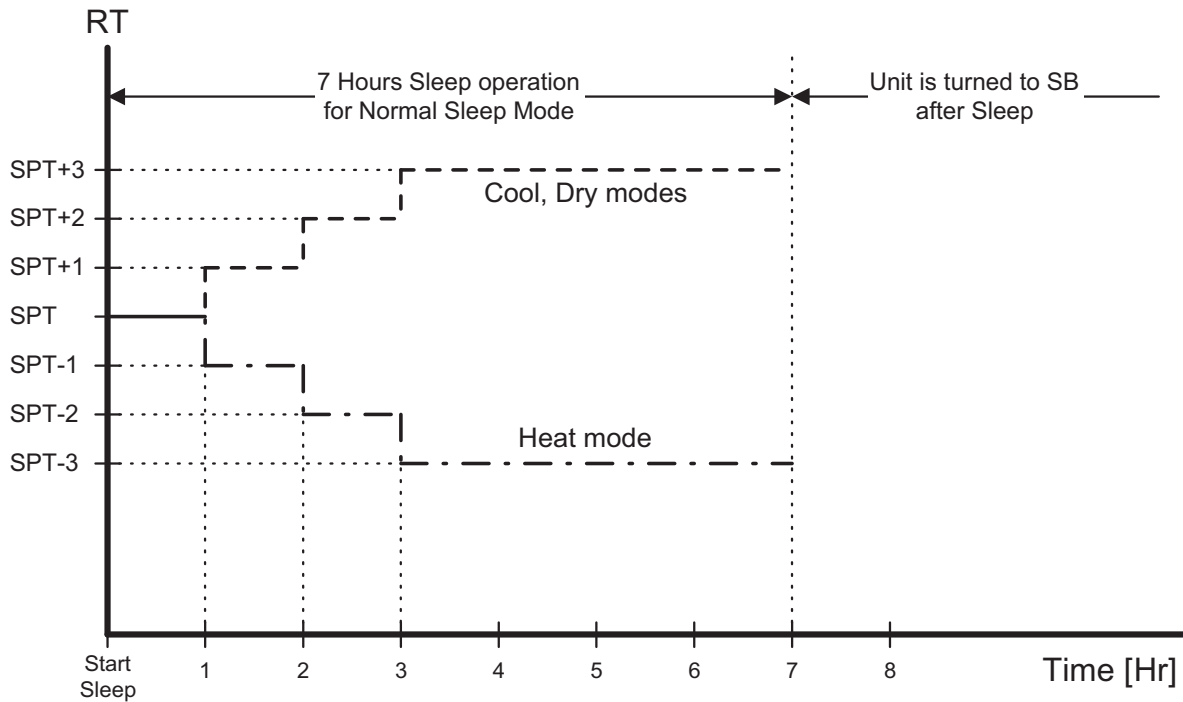

Note: If Off-timer is active, the unit may go to SB before or after 7 hours of sleep operation.

12.12.2 Time adjustment in Sleep Mode

The user can make use of the Off-Timer to extend the Sleep Time from 7 hours to 12 hour (max). The operation of the new “Extended Sleep Mode” is illustrated by the graphs below.

Case 1 is the Standard Sleep Mode, which is the only sleep mode in previous version of MCU. The A/C unit simply works for 7 hours, then goes to SB.

Case 2 is the new Extended Sleep Mode. If an active Off-Timer is set to turn off the A/C between 7-12 hour, relative to the starting of Sleep, the Sleep time is extended.

And, instead of going to SB at the 7th hour, the A/C will work until reaching the Off-time.

Case 3 is an exception to case 2. The Sleep Mode will not be extended to the Off-Time when the Off-Timer is preceded by an On-Timer, which is also between 7-12 hour.

Case 1 : Standard Sleep Mode

Condition : Off-timer is not set or is beyond 12 hour.

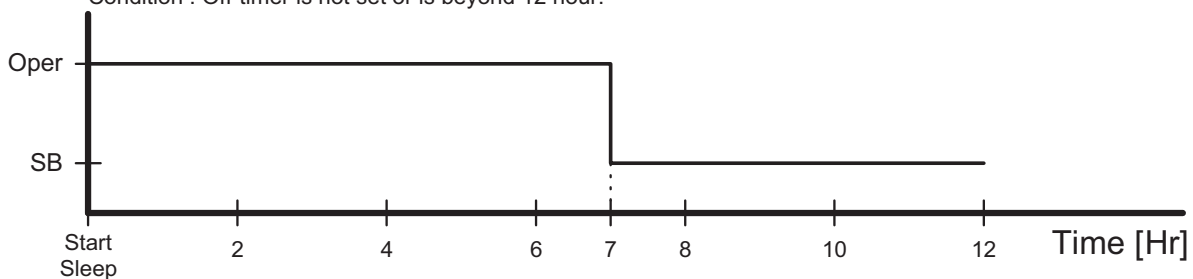

Case 2 : Extended Sleep Mode

Condition : Off-timer is set at 7-12 hour.

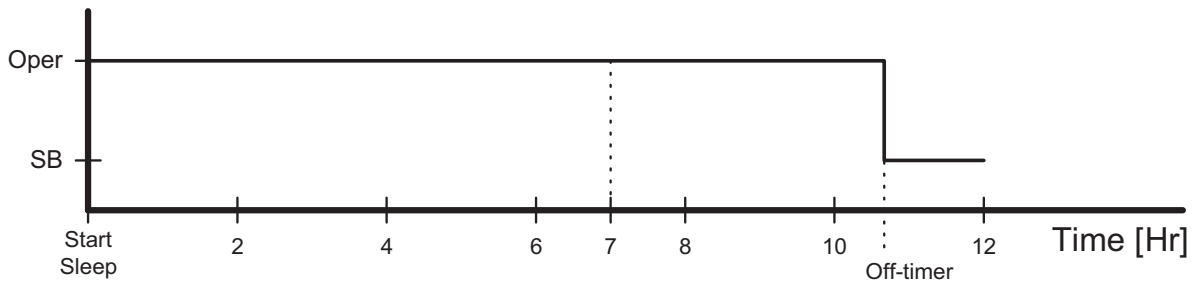

Case 3 : Exception to Case 2

Condition : Off-timer is set at 7-12 hour

On-timer is set at 7-12 hour and before Off-timer

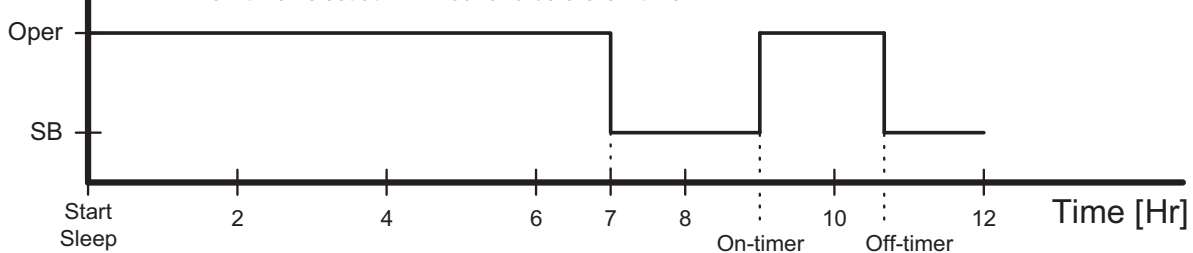

12.13 Clogged Air Filter

Filter LED ON after 512 HR.

Filter LED is turned OFF, and the Filter Timer is restarted by pressing the reset button.

12.14 Controller Self-Test Procedure

12.14.1 By Shorting Test Jumper J1

SELF-TEST FLOW CHART
FOR CONTROLLER (VERSION 4V5 OR HIGHER)

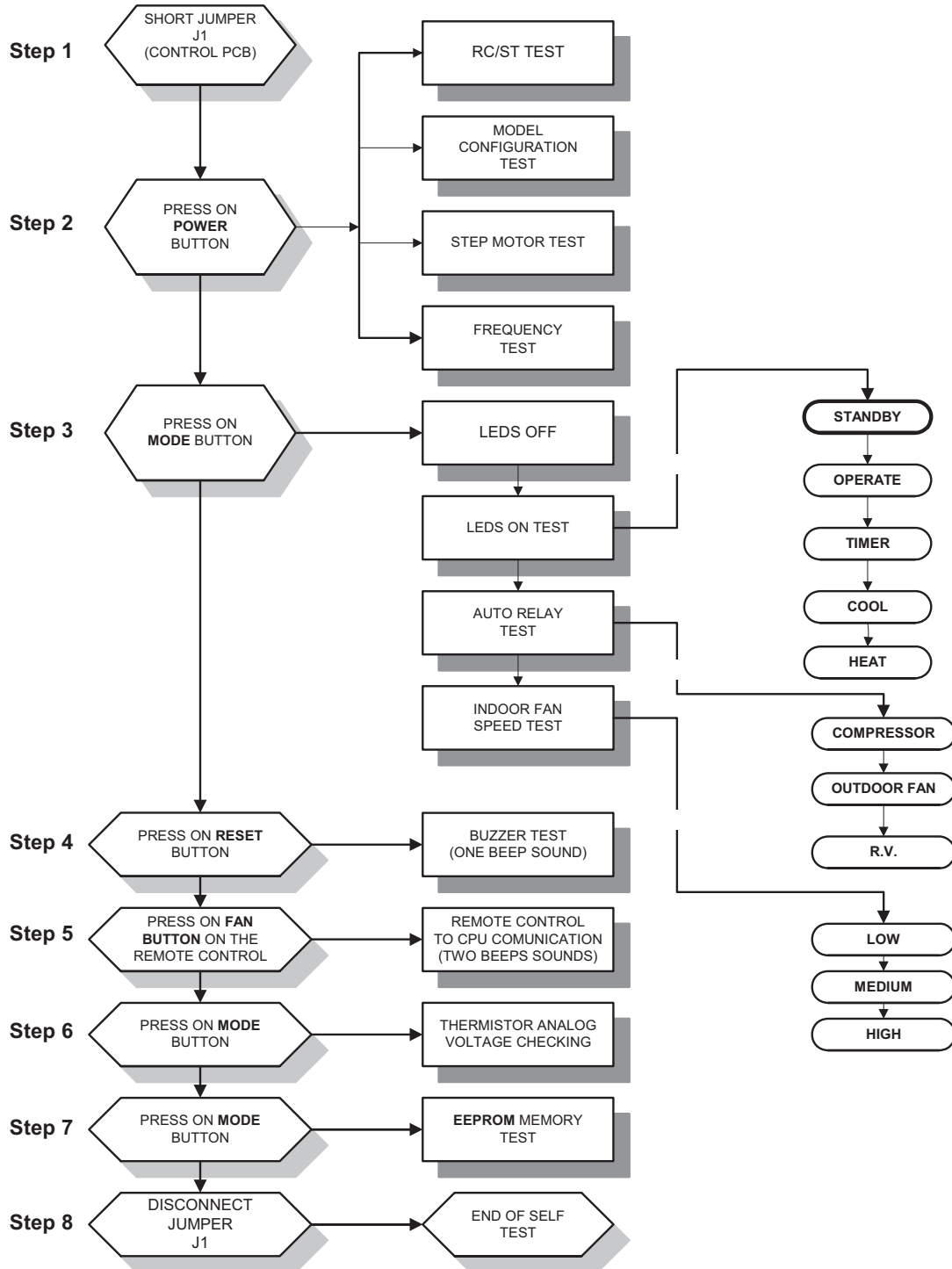

12.14.2 By Remote Control Settings:

- a. 1: TURNING ON THE POWER.
Turn ON the power, make sure that the unit is in operation.
- b. STEP 2 : ENABLE SELF-TEST MODE
 - Use the remote control to send the first settings to display / indoor unit HEAT mode, HIGH IFAN, set temperature to 16 °C, no I-FEEL Sleep or any other timer settings are needed.
 - Cover the IR transmitter components in the remote control so that it will not transmit the signals to the indoor unit display.
 - Use the remote control to send the second settings to display / indoor unit COOL mode, LOW IFAN, no I-FEEL Sleep or any other timer settings.
 - Uncover the remote control IR transmitter and change the temperature settings. If the display/indoor unit receive the settings properly the following steps will start:
- c. STEP 3: MODEL SETTING CONFIRMATION
 - The STAND-BY and COOL LEDS will indicate the operation mode as follows:

OPERATION MODE	STAND-BY LED	COOL LED
ST	ON	OFF
RC	OFF	OFF
SH	OFF	ON
RH	ON	ON

- Testing the Model configuration. Selected by the COMP, STAND-BY, TIMER LEDS and FILTER will indicate the model configuration as follows (the relevant line for this manual is highlighted):

MODEL	COMP	OPERATE LED	TIMER LED	FILTER LED
WNG	ON	OFF	OFF	OFF
WMN1	ON	ON	OFF	ON
WMN4	OFF	OFF	ON	OFF
WMN2/WHX	OFF	ON	OFF	ON
WMN3	OFF	ON	ON	ON

In this term the step motor will turn to HOME POSITION.

d. STEP 4 : AUTO LED WALK TEST.

- All the LEDS will turn OFF.
- All the LEDS will turn ON for 1 second one by one in the following sequence:
STAND-BY ⇨ OPERATE ⇨ TIMER ⇨ FILTER ⇨ COOL ⇨ HEAT.
- In PRX all the LEDS will turn ON for 1 second one by one in the following sequence : 18 °c ⇨ 20 °c ⇨ 22 °c ⇨ 24 °c ⇨ 26 °c ⇨ 28 °c ⇨ 30 °c ⇨ High IFAN ⇨ Auto IFAN ⇨ Med IFAN ⇨ Low IFAN ⇨ STAND-BY⇨ TIMER ⇨ FILTER ⇨COOL⇨ HEAT.

e. STEP 5: AUTO REALY WALK TEST:

- All relays will energize one by one in the following sequence:
COMPRESSOR ⇨ OUTDOOR FAN⇨R. V. ⇨ HEATER 1 ⇨ HEATER 2
⇨ INDOOR WATER PUMP ⇨ SWING or OUTDOOR WATER PUMP ⇨
INDOOR FAN: LOW ⇨ MID ⇨ HIGH.
- When the relay walk test is completed, the next test will start automatically.

f. STEP 6: FREQUENCY TESTING:

- If the frequency measuring process fails the COOL LED will turn ON. In order to move to the next step, press ON/OFF button on the remote control.

g. STEP 7: INPUT TEST.

- The test purpose is to check the analog real time indicators (thermistors, LEVEL and clock) according to the table below.

LED Indicator	Condition for LED to be ON
STBY LED	Room thermistor ≠ 25°C
OPER LED	Indoor coil thermistor ≠ 25°C
TIMER LED	Outdoor coil thermistor ≠ 25°C
FILTER LED	Clock
COOL LED	LEVEL 2&3
HEAT LED	LEVEL 4

h. STEP 8: TIMING RESET TEST (WATCH DOG).

- The test purpose is to verify that the CPU rise time after power failure is between 1 to 3 sec, test results are indicated on the LEDS : STAND-BY,OPER, TIMER and FILTER turning ON one by one.
- The results of the test are coded as follows:
Pass condition:
1 sec - STAND-BY and OPER are turned ON
2 sec - STAND-BY, OPER and TIMER are turned ON

Fail condition:

0 sec - STAND-BY is turned ON

3 sec - STAND-BY, OPER, TIMER and FILTER are turned ON

- When the timing reset test is completed, the next test will start automatically.

i. STEP 9: MEMORY TEST (EEPROM)

- The test purpose is to check if the memory is functioning correctly. The test result is reported by using the STAND-BY and FILTER LEDs:

LED Indicator	Condition for LED to be ON
STAND-BY LED	Test passed
FILTER LED	Test failed

AT THIS POINT THE SELF-TEST IS COMPLETED.

In order to terminate Self-Test mode the User can change the unit setting from COOL Mode, LOW FAN to COOL Mode, MED FAN or to wait without using the remote control for 60 sec.

Values of Sensors Temperature VS. Voltage (DC)

Temp. (*C)	Voltage (V)	Temp. (*C)	Voltage (V)	Temp. (*C)	Voltage (V)	Temp. (*C)	Voltage (V)
-20	4.554	2	3.744	24	2.555	46	1.487
-19	4.529	3	3.695	25	2.5	47	1.447
-18	4.502	4	3.646	26	2.445	48	1.409
-17	4.475	5	3.595	27	2.391	49	1.371
-16	4.446	6	3.544	28	2.338	50	1.334
-15	4.417	7	3.492	29	2.284	51	1.298
-14	4.386	8	3.439	30	2.232	52	1.263
-13	4.354	9	3.386	31	2.18	53	1.228
-12	4.322	10	3.332	32	2.128	54	1.195
-11	4.287	11	3.278	33	2.077	55	1.162
-10	4.252	12	3.223	34	2.027	56	1.13
9	4.216	13	3.168	35	1.978	57	1.099
-8	4.178	14	3.113	36	1.929	58	1.069
-7	4.14	15	3.058	37	1.881	59	1.04
-6	4.1	16	3.002	38	1.834	60	1.011
-5	4.059	17	2.946	39	1.798	61	0.983
-4	4.017	18	2.89	40	1.742	62	0.956
-3	3.974	19	2.833	41	1.698	63	0.929
-2	3.93	20	2.777	42	1.654	64	0.904
-1	3.885	21	2.722	43	1.611	65	0.879
0	3.839	22	2.666	44	1.569	66	0.854
1	3.792	23	2.61	45	1.527	67	0.831

12.15 On Unit Indicators and Controls

STAND BY INDICATOR	Lights up when the Air Conditioner is connected to power and ready to receive the R/C commands Blinks continuously in case of any thermistor failure.
OPERATION INDICATOR	Lights up during operation. Blinks for 300 ms, to announce that a R/C infrared signal has been received and stored. Blinks continuously during <ul style="list-style-type: none"> • OCT High Pressure Protection Mode • ICT High Pressure Protection Mode • Deicing in Heating Mode • Water Over Flow in ECC Model
TIMER INDICATOR	Lights up during Timer and Sleep operation.
FILTER INDICATOR	Lights up when Air Filter needs to be cleaned. Blinks during Water Over Flow in MBX/P2000 models.
COOLING INDICATOR	Lights up when system is switched to Cool Mode by using the Mode Switch <u>on the unit</u> . Show the thermistor status in Diagnostic Mode
HEATING INDICATOR	Lights up when system is switched Heat Mode by using the Mode Switch <u>on the unit</u> . Show the thermistor status in Diagnostic Mode.
MODE BUTTON (Cool, Heat, SB)	Use to cycle the operation mode of the A/C unit among COOL, HEAT and SB modes, without using the R/C. Every time this switch is pressed, the next operation mode is selected, in this order : SB → Cool Mode → Heat Mode → SB → ... Press this button continuously for 5 sec or more to start the Diagnostic Mode.
RESET / FILTER BUTTON	When the Filter LED is ON, press to turn off the Filter LED after a clean filter has been reinstalled. When the Filter LED is OFF, use this button to enable/disable the buzzer announcer.

12.16 Clock Random Delay From 0 to 2.5 seconds

- 0 = Clock Switch Open
 1 = Clock Switch close

The Clock is activate according to the following table:

A/C STATE (before clock is changed)	CLOCK STATE (before clock is changed)	CLOCK ACTION (clock is changed)	A/C NEW STATE (after clock is changed)
ON	1	0	OFF
OFF	0	1	ON
OFF by interrupt ⁽¹⁾	1	0	OFF
ON by interrupt ⁽¹⁾	0	1	ON

Notes :

1. Clock can be interrupted by :
 - R/C - POWER ON/OFF Push-button.
 - R/C - TIMER.
 - R/C - SLEEP.
 - A/C - MODE SWITCH.
2. Any change in the CLOCK level during the first 6 sec after the system Reset is ignored.

12.2 System Diagnostics

Pressing Mode button for 5-10 seconds in SB or any other operation mode will activate diagnostic mode by the acknowledgment of 3 short beeps and lighting of COOL and HEAT LEDs.

In diagnostic mode, system problems will be indicated by blinking of Heat & Cool LEDs.

The coding method will be as follow:

Heat led will blink 5 times in 5 seconds, and then will be shut off for the next 5 seconds. Cool led will blink during the same 5 seconds according to the following table:

No	Problem	○	○	○	○	○
1	RT1 is disconnected	○	●	●	●	●
2	RT1 is shorted	○	●	●	●	○
3	(Reserved)	○	●	●	○	●
4	RT2 is disconnected	●	○	●	●	●
5	RT2 is shorted	●	○	●	●	○
6	(Reserved)	●	○	●	○	●
7	RT2 temp reading doesn't change	●	○	●	○	○
8	RT3 is disconnected	●	●	○	●	●
9	RT3 is shorted	●	●	○	●	○
10	(Reserved)	●	●	○	○	●
11	RT3 temp reading doesn't change	●	●	○	○	○
12	RT2 & RT3 temp reading doesn't change	●	○	○	○	○

○ - ON, ● - OFF

Notes:

1. If faults occur in more than one thermistor (except case number 12 on table above), only one fault will be indicated according to the following order: RT3, RT2, RT1.

2. A/C will jump out to normal mode if sending a command by the R/C in system diagnostics mode. If this command from the R/C contain a Group ID, this ID will become the new Group ID of the ELCON unit.

13. TROUBLESHOOTING

No	SYMPTON	PROBABLE CAUSE	CORRECTIVE ACTION
1.	The stand-by indicator (red led) on the central control display panel doesn't light up.	There is no correct voltage between the line and neutral terminals on main P.C.B	-If the voltage is low repair power supply. -If there is no voltage repair general wiring. -If there is correct voltage replace main or display P.C.B'S
2.	The operation indicator (green led) on the central control display panel does not light up.	The remote control batteries are discharged	-Replace batteries of the remote control.
3.	The operation indicator (green led) does not light up when starting from unit.	Check main P.C.B and display P.C.B	-Replace P.C.B if necessary.
4.	The indoor fan does not function correctly.	Check the voltage between indoor fan terminals on the main P.C.B	-If there is voltage replace capacitor or motor.
5.	The outdoor fan does not function correctly.	Check the voltage between out door fan terminals on the main P.C.B There is voltage between outdoor fan terminals on the outdoor unit. There is no voltage between outdoor fan terminals on the outdoor unit.	-If there is no voltage replace main P.C.B -Replace capacitor or motor. -Check and repair electrical wiring between indoor and outdoor units
6.	The compressor does not start up.	Check voltage on compressor terminals on the outdoor unit. (with ammeter) Check if there is correct voltage between compressor terminals on the outdoor unit.	-If no voltage replace main P.C.B -If low voltage repair power supply. -If the voltage correct replace capacitor or compressor. -If there is no voltage repair electrical wiring between indoor and outdoor units.
7.	The refrigeration system does not function correctly.	Check for leaks or restrictions. With ammeter. Pressure gauge or surface thermometer.	-Repair refrigeration system and charge refrigerant if necessary.
8	No cooling or heating only indoor fan works.	Outdoor fan motor faulty or other fault caused, compressor overload protection cut out.	-Replace P.C.B. -Outdoor fan blocked remove obstructions.

№	SYMPTON	PROBABLE CAUSE	CORRECTIVE ACTION
9.	Only indoor fan and compressor working.	Outdoor fan blocked.	-Remove obstructions.
10.	Only indoor fan working.	-Run capacitor of outdoor fan motor faulty. -Windings of outdoor fan are shorted.	-Replace capacitor. -Replace motor.
11.	No cooling or heating takes place, indoor fans working.	-Overload safety device on compressor is cut out (low voltage or high temperature). -Compressor runs capacitor faulty. -Compressor windings are shorted.	-Check for proper voltage, switch off power and try again after one hour. -Replace compressor capacitor. -Replace compressor.
12.	No air supply at indoor unit, compressor operates.	-Indoor fan motor is blocked or turns slowly. -Indoor fan run capacitor faulty. -Motor windings are shorted.	-Check voltage, repair wiring if necessary. -Check fan wheel if it is tight enough on motor shaft, tighten if necessary.
13.	Partial, limited air supply at indoor unit.	Lack of refrigerant (will accompanied by whistling noise) cause ice formation on indoor unit coil in cooling mode.	-charge the unit after localizing leak.
14.	Water accumulates and over flow from indoor unit section.	Drain tube or spout of drain pan clogged.	-Disassemble plastic drain tube from spout of indoor unit drain pan.
15.	Water dripping from outdoor unit base, (in heating mode).	Water drain outlet is clogged.	-Open outdoor unit cover clean out water outlet clean the base inside thoroughly.
16.	Freeze-up of outdoor coil in heating mode, poor heating effect in room, indoor fan operates.	-Faulty outdoor thermistor. -Faulty control cable. -Outdoor temperature is below design conditions. -Outdoor unit air outlet is blocked.	-Replace thermistor. -Repair control cable. -Shut unit off, it cannot work properly. -Remove obstructions.
17.	Unit is in heat mode but operating in cooling.	-Faulty RV coil. -RV coil is ok valve is stuck position.	-Replace RV coil. -Replace the reversing valve.

14. EXPLODED VIEWS AND SPARE PARTS LISTS

14.1 Indoor Unit: DELTA 18, 21, 24

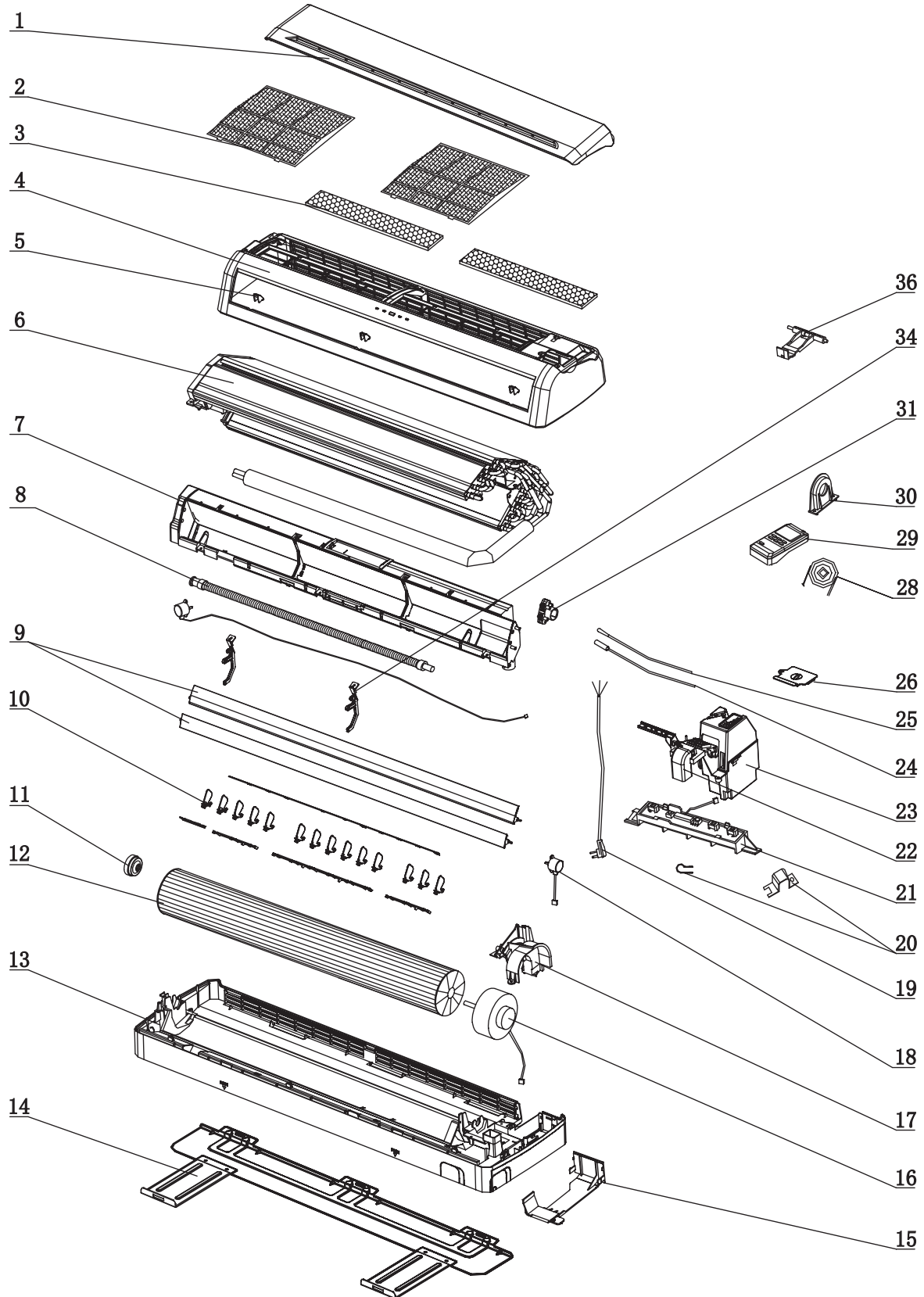

14.2 Indoor Unit: DELTA 18, 21, 24

No.	Item	Description	Quan.
1	465020098	Front Plate/Delta 18&24 Fagor	1
2	452919800	Filter	2
3	4518113	Fiber Filter Assy.	1
4	465720204	Silk-Screen Front Frame Assy./Delta 18-24 Fagor Electra	1
5	452919600	Screw cover	3
6	462350084	Evaporator Assy./WNG21/24 R410A	1
	453046600	Evaporator Assy./WNG18 R410A	1
7	452917300	Air outlet	1
8	465210009	Drain Pipe for Israel /WNG18/24/30	1
9	452917500	Horizontal flap A	1
9	452917600	Horizontal flap B	1
10	452930700	Vertical flap A	12
10	452918200	Vertical flap B	2
11	4518662	Bearing assy fan	1
12	453024900	Impeller fan	1
13	453053800	Base assy./WNG18	1
14	452920100	Mount bracket/WNG-18	1
15	452919400	Joint/Unit housing	1
16	453134300R	Resin Motor 26W/WNG24 LED (DELTA21,24)	1
	453116500R	Resin Motor 18W/WNG18 LED (DELTA18)	1
17	452918800	Cover/motor	1
18	453050300	STEP MOTOR B	1
20	4519147	Power Cord Clip	1
20	452919200	Tie/connection Wire	1
21	467300197R	Display Board/Delta 18 F	1
22	452919100	Support/sensor	1
22	4516263	SENSOR BASE	1
23	467300201R	Controller/Delta F 18 S/W:10V14	1
24	438082	Thermistor Indoor coil BLACK.	1
25	467400025	Indoor Air Inlet Temperature Sensor	1
26	452919500	Cover/terminal	1
28	4520416	Defrost cable EXPORT UNITS.	1
29	438600R	Remote controller RC3-RC 973-600-00	1
30	4518651	Cover Side Motor	1
31	453057900	Gear BOX ASSY	1
34	452918700	Support/horizontal louver	2
36	4518657	TUBE LOCK	1

14.3 Outdoor Unit: GC 18 ST

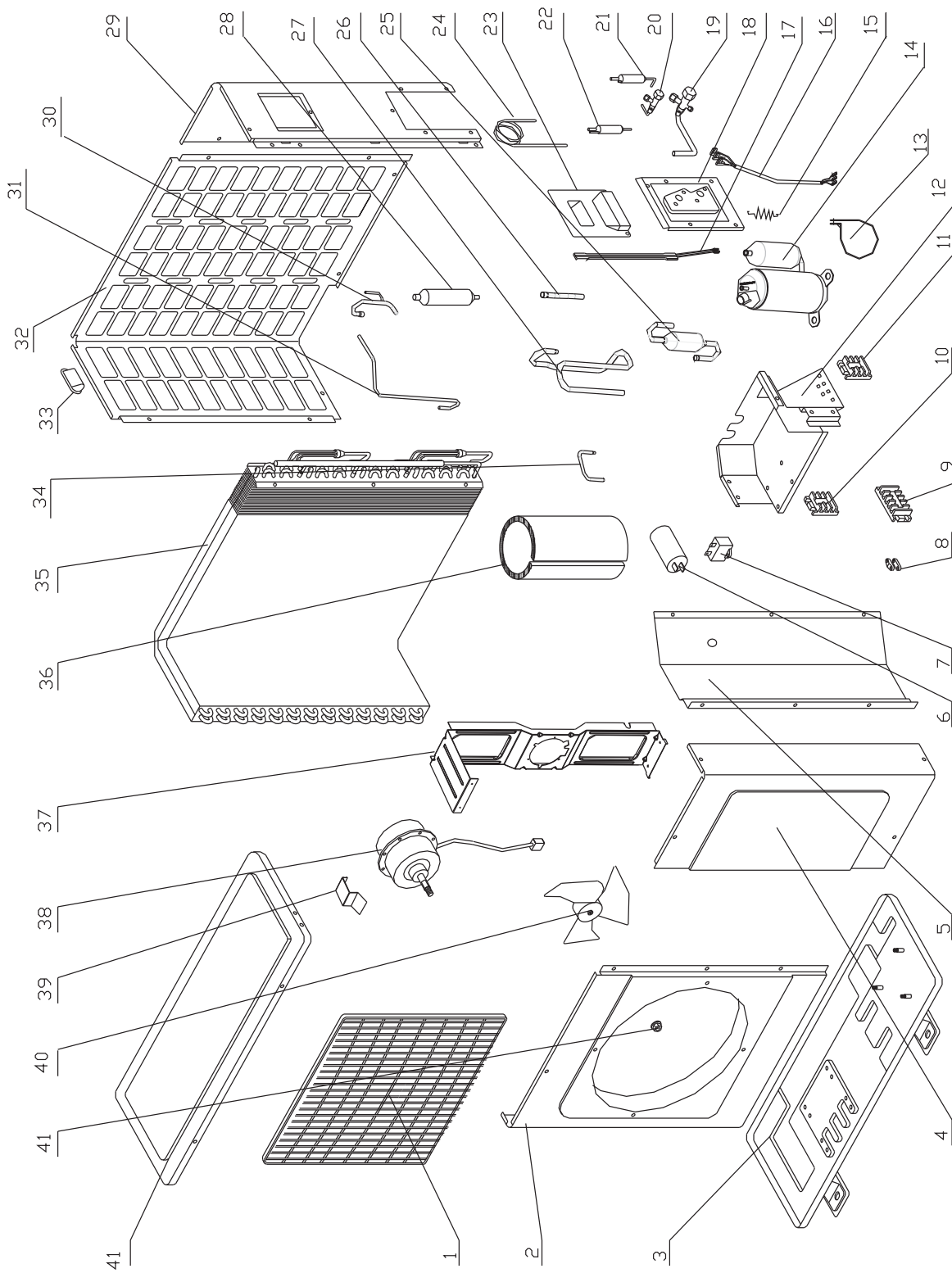

14.4 Outdoor Unit: GC 18 ST

No.	Part No.	Description	Quantity
1	4517144	FAN COVER PP+UV	1
2	452795700	PAINTED LEFT CABINET ASSY	1
3	452989200	Base welding plate assy.	1
4	4516786	PAINTED RIGHT CABINET ASSY	1
5	4516985	Partition Plate	1
6	455000506	Compressor Capacitor With Screw 45uF (CBB65)	1
7	455000104	Double patch Capacitor for fan motor 4uF (CBB61S)	1
8	204107	Cable clip Nylon	2
9	4521744	3 Poles Terminal Block (4mm2)	1
10	4522469	4 LEVEL TERMINAL BLOCK	1
11	4521733	3 Poles Terminal Block (6mm2)	1
12	4521340	Controller Box	1
13	4525427	Clip for capacitance(d=50)	1
14	453089900	Compressor Assy.PA200X2CS-4KU1	1
15	4519000	Spring of compressor heater	1
16	4517345	COMPRESSOR WIRE ASSY. 2.5mm2	1
17	4526922	heater for compressor	1
18	4516766	PAINTED VALVE PLATE ASSY	1
19	4526530	LOW PRESS VALVE (R410A)	1
20	4526531	High press valve(R410A)	1
21	4526931	filter welding assy. 2	1
22	4526839	filter welding assy.	1
23	4523145	R.lifter	1
24	452821900	Capillary assy. for cooling	1
25	4523338	Accumulator assy.	1
26	452977200	Low pressure pipe	1
27	452976200	Suction pipe 1	1
28	4526291	Muffler	1
29	4525938	PAINTED RIGHT-BACK CABINET ASSY	1
30	452977000	Condenser pipe assy.	1
31	452976800	Discharge pipe 2	1
32	4517028	PAINTED LEFT-BACK GRILL	1
33	4516758	SMALL HANDLE	1
34	452976000	Discharge pipe 1	1
35	452821300	Condenser-Distributing Soldering Assy.GC-18ST R410A	1
36	452988800	Insulation for compressor PA215/240	1
37	4526509	MOTOR BRAKECT (new)	1
38	4526864	motor YYK85E-6	1
39	4526585	connect for motor basket	1
40	4526510	FAN D=460mm (3 blade)	1
41	4523141	Hexagon locked nut M10	1
42	4516788	PAINTED TOP COVER ASSY	1

14.5 Outdoor Unit GC 18 RC

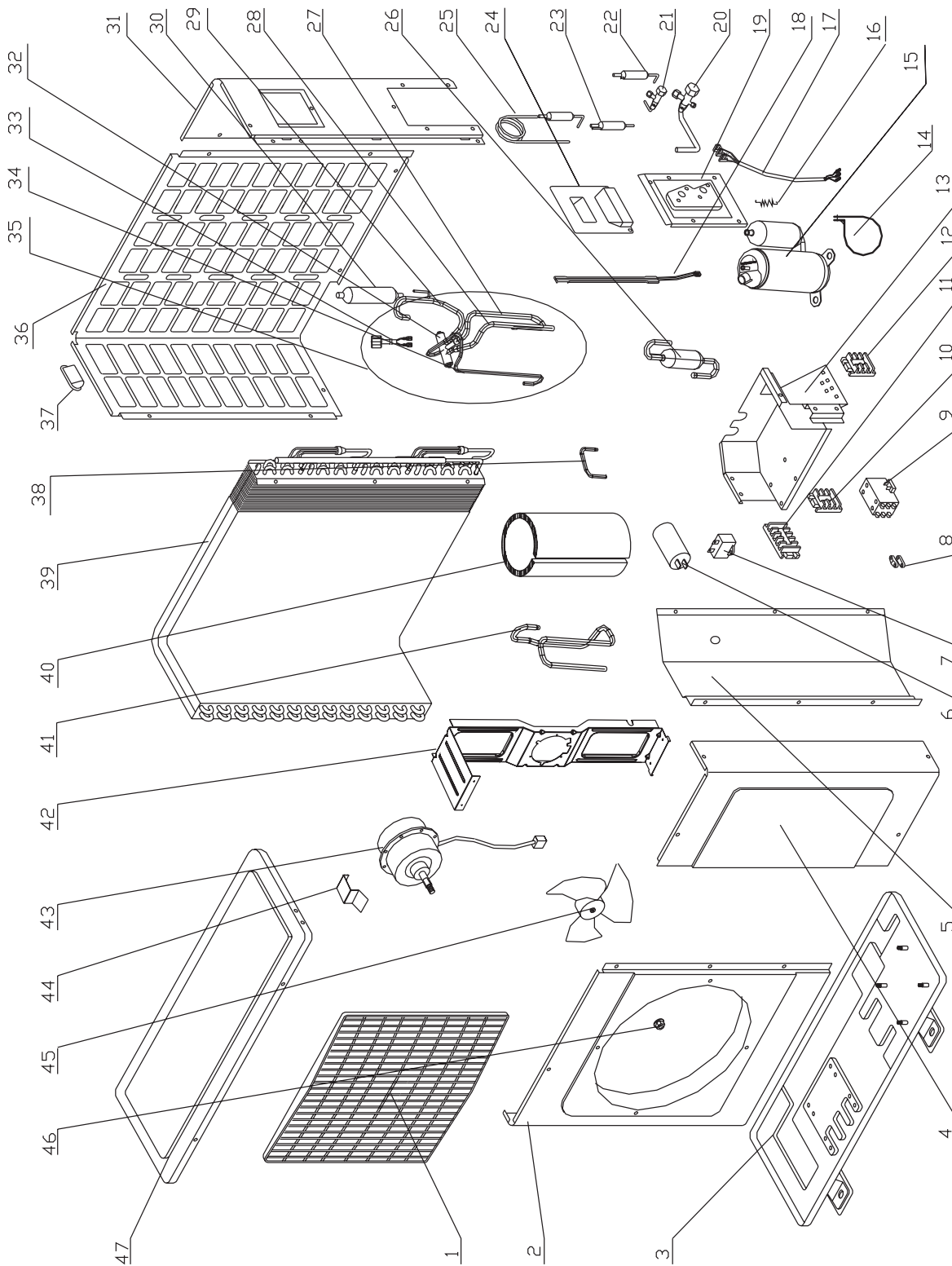

14.6 Outdoor Unit: GC 18 RC

No.	Part No.	Description	Quantity
1	4517144	COVER PP+UV	1
2	452795700	PAINTED LEFT CABINET ASSY	1
3	452989200	Base welding plate assy.	1
4	4516786	PAINTED RIGHT CABINET ASSY	1
5	4516985	Partition Plate	1
6	455000506	Compressor Capacitor With Screw 45uF (CBB65)	1
7	455000104	Double patch Capacitor for fan motor 4uF (CBB61S)	1
8	204107	Cable clip Nylon	2
9	4524907	contactor (CJX9B-25S/01)	1
10	4521744	3 Poles Terminal Block (4mm ²)	1
11	4522469	4 LEVEL TERMINAL BLOCK	1
12	4521733	3 Poles Terminal Block (6mm ²)	1
13	4521340	Controller Box	1
14	4525427	Clip for capacitance(d=50)	1
15	453089900	Compressor Assy.PA200X2CS-4KU1	1
16	4519000	Spring of compressor heater	1
17	4517345	COMPRESSOR WIRE ASSY. 2.5mm ²	1
18	4526922	Heater for compressor	1
19	4516766	PAINTED VALVE PLATE ASSY	1
20	4526530	LOW PRESS VALVE (R410A)	1
21	4526531	High press valve(R410A)	1
22	4526931	filter welding assy. 2	1
23	4526839	filter welding assy.	1
24	4523145	R.lifter	1
25	4526840	Single-way welding assy.	1
26	4523338	Accumulator assy.	1
27	452976500	Suction pipe 2	1
28	452976600	Low pressure pipe	1
29	452976400	Condenser pipe assy.	1
30	4526291	Muffler	1
31	4525938	PAINTED RIGHT-BACK CABINET ASSY	1
32	4526522	FOUR-WAY VALVE R410A	1
33	4526589	4-Way Valve Coil FOR R410A	1
34	452976100	Discharge pipe 2	1
35	452987800	4-way welding assy. for GC18RC R410A PA200	1
36	4517028	PAINTED LEFT-BACK GRILL	1
37	4516758	SMALL HANDLE	1
38	452976000	Discharge pipe 1	1
39	452796500	Condenser-Distributing Soldering Assy.GC-18RC R410A	1
40	452988800	Insulation for compressor PA215/240	1
41	452976200	Suction pipe 1	1
42	4526509	MOTOR BRAKECT (new)	1
43	4526862	motor YYK85E-6B for GC18RC	1
44	4526585	connect for motor basket	1
45	4526510	FAN D=460mm (3 blade)	1
46	4523141	M10 Hexagon locked nut M10	1
47	4516788	PAINTED TOP COVER ASSY	1

14.7 Outdoor Unit: GC 21 RC

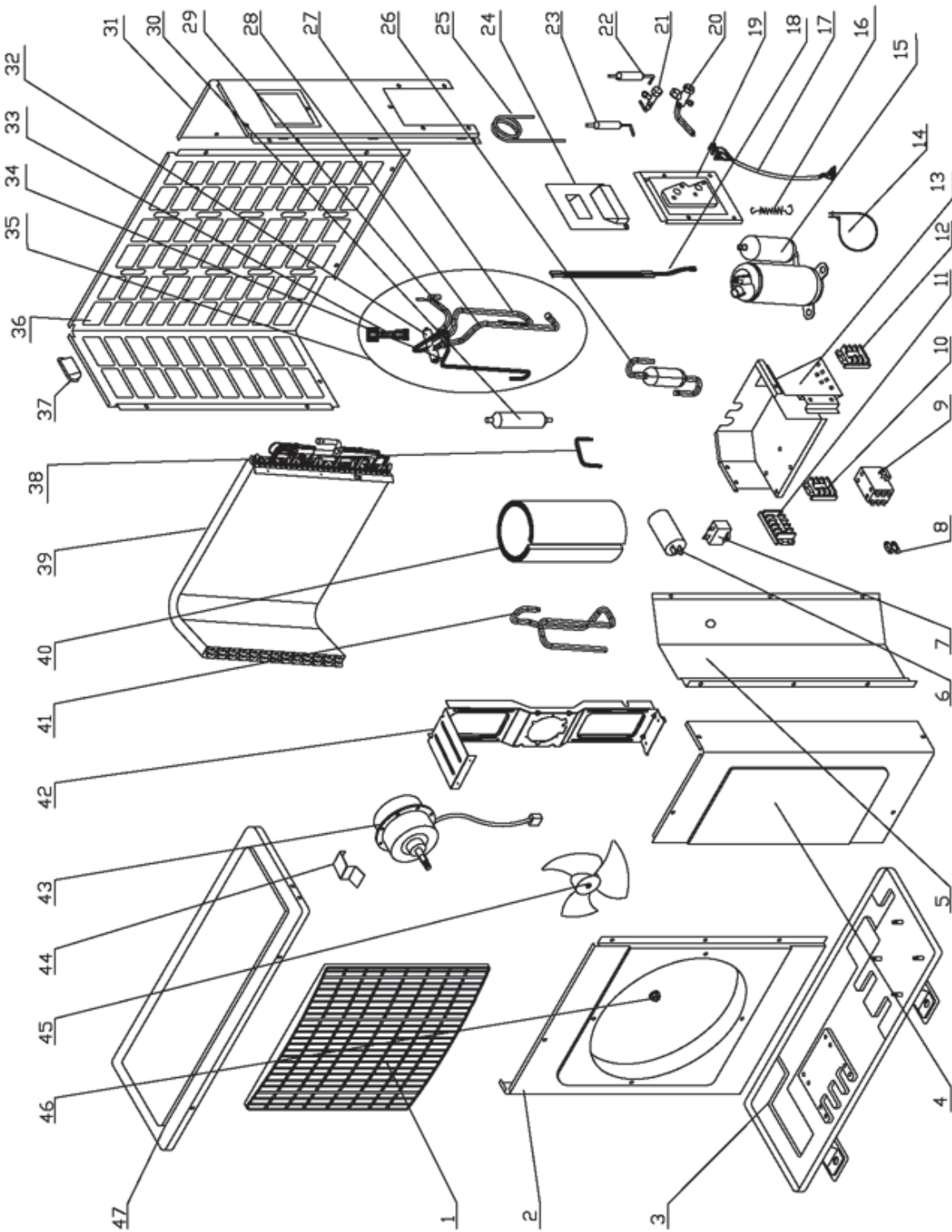

14.8 Outdoor Unit: GC 21 RC

No.	Part No	Description	Qty
1	4517144	FAN COVER PP+UV	1
2	452795700	PAINTED LEFT CABINET ASSY	1
3	452989200	Base welding plate assy.	1
4	4516786	PAINTED RIGHT CABINET ASSY	1
5	4516985	Partition Plate	1
6	455000507	Compressor Capacitor With Screw 50uF (CBB65)	1
7	455000104	Double patch Capacitor for fan motor 4uF (CBB61S)	1
8	204107	Cable clip Nylon	2
9	4524907	Contacto (CJX9B-25S/01)	1
10	4521744	3 Poles Terminal Block (4mm2)	1
11	4522469	4 LEVEL TERMINAL BLOCK	1
12	4521733	3 Poles Terminal Block (6mm2)	1
13	4521340	Controller Box	1
14	4525427	Clip for capacitance(d=50)	1
15	452975900	Compressor assy.PA240X2CS-4KU1	1
16	4519000	Spring fo compressor heater	1
17	4517345	COMPRESSOR WIRE ASSY. 2.5mm2	1
18	452988900	Heater for compressor	1
19	4516766	PAINTED VALVE PLATE ASSY	1
20	4526513	LOW PRESS VALVE (R410A)	1
21	4526514	Hight press valve(R410A)	1
22	452891100	Filter assy 1	1
23	452891200	Filter assy 2	1
24	4523145	R.lifter	1
25	463750005	Single-way welding assy	1
26	4523338	Accumulator assy	1
27	452976500	Suction pipe 2	1
28	452976700	Low pressure pipe	1
29	452976300	Condenser pipe assy	1
30	4526291	Muffler	1
31	4525938	PAINTED RIGHT-BACK CABINET ASSY	1
32	4526522	FOUR-WAY VALVE R410A	1
33	4526589	4-Way Valve Coil FOR R410A	1
34	452976100	Discharge pipe 2	1
35	452987700	4-way welding assy.	1
36	4517028	PAINTED LEFT-BACK GRILL	1
37	4516758	SMALL HANDLE	1
38	452976000	Discharge pipe 1	1
39	452882900	Condenser and distributor welding assy.	1
40	452988800	Insulation for compressor	1
41	452976200	Suction pipe 1 for PA240	1
42	4526509	MOTOR BRAKECT (new)	1
43	4526864	Motor YYK85E-6	1
44	452907400	Hook for condenser	1
45	4526510	FAN D=460mm (3 blade)	1
46	4523141	Hexagon locked nut M10	1
47	4516788	PAINTED TOP COVER ASSY	1

14.9 Outdoor Unit: GC 21 ST

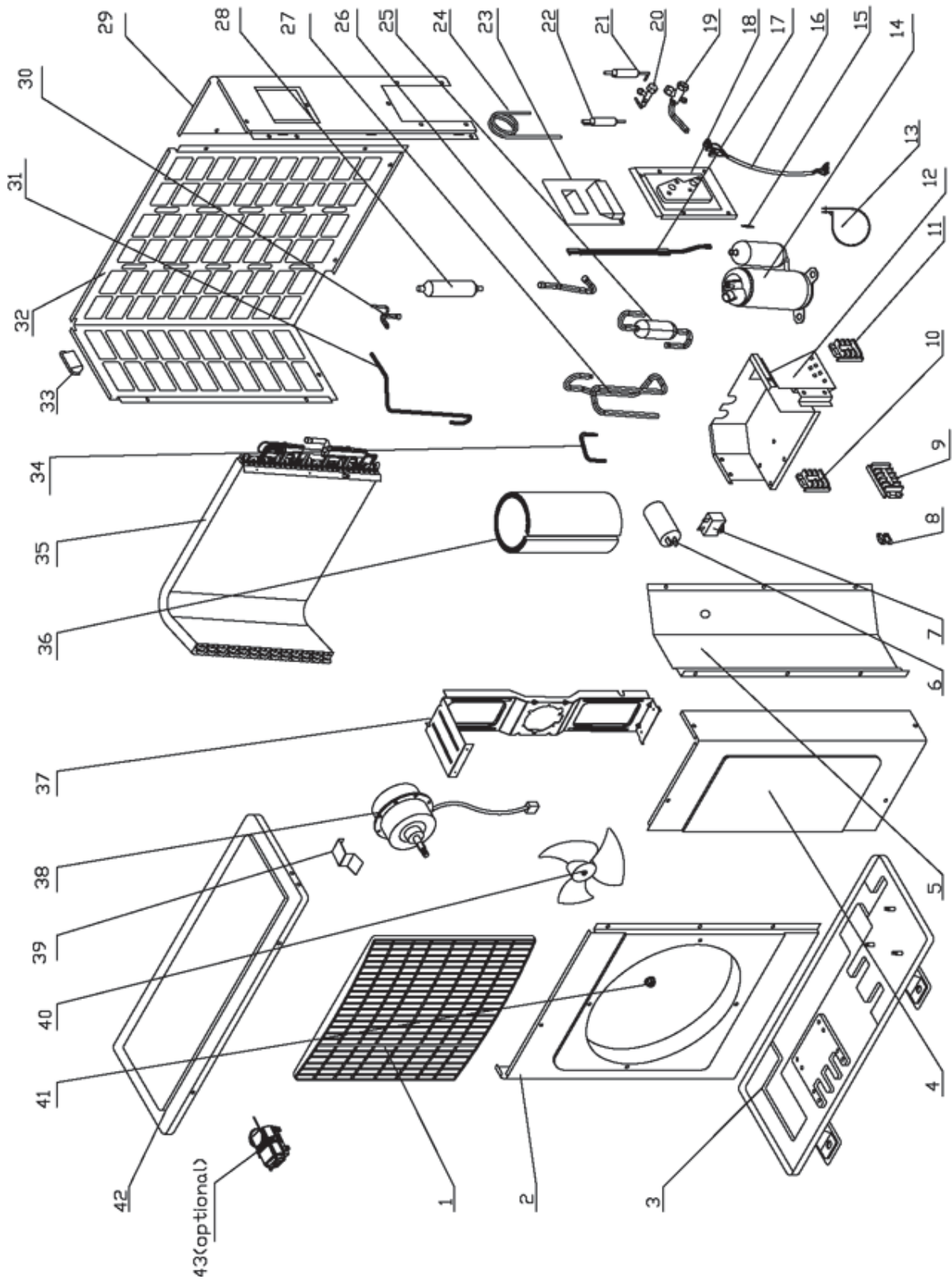

14.10 Outdoor Unit: GC 21 ST

No	Part No	Description	Qty
1	4517144	COVER PP+UV	1
2	452795700	PAINTED LEFT CABINET ASSY	1
3	452989200	Base welding plate assy.	1
4	4516786	PAINTED RIGHT CABINET ASSY	1
5	4516985	Partition Plate	1
6	455000507	Compressor Capacitor With Screw 50uF (CBB65)	1
7	455000104	Double patch Capacitor for fan motor 4uF (CBB61S)	1
8	204107	Cable clip Nylon	2
9	4522469	4 LEVEL TERMINAL BLOCK	1
10	4521744	3 Poles Terminal Block (4mm ²)	1
11	4521733	3 Poles Terminal Block (6mm ²)	1
12	4521340	Controller Box	1
13	4525427	Clip for capacitance(d=50)	1
14	452975900	Compressor assy.PA240X2CS-4KU1	1
15	4519000	Spring fo compressor heater	1
16	4517345	COMPRESSOR WIRE ASSY. 2.5mm ²	1
17	452988900	Heater for compressor	1
18	4516766	PAINTED VALVE PLATE ASSY	1
19	4526513	LOW PRESS VALVE (R410A)	1
20	4526514	Hight press valve(R410A)	1
21	452891100	Filter assy 1	1
22	452891200	Filter assy 2	1
23	4523145	R.lifter	1
24	463600001	Capillary welding assy.	1
25	4523338	Accumulator assy	1
26	452977300	Low pressure pipe	1
27	452976200	Suction pipe 1 for PA240	1
28	4526291	Muffler	1
29	4525938	PAINTED RIGHT-BACK CABINET ASSY	1
30	452977100	Condenser pipe assy.	1
31	453018400	Discharge pipe 2	1
32	4517028	PAINTED LEFT-BACK GRILL	1
33	4516758	SMALL HANDLE	1
34	452976000	Discharge pipe 1	1
35	452897800	Condenser and distributor welding assy.	1
36	452988800	Insulation for compressor	1
37	4526509	MOTOR BRAKECT (new)	1
38	4526864	motor YYK85E-6	1
39	452907400	Hook for condenser	1
40	4526510	FAN D=460mm (3 blade)	1
41	4523141	Hexagon locked nut M10	1
42	4516788	PAINTED TOP COVER ASSY	1

14.11 Outdoor Unit GCN 12 RC

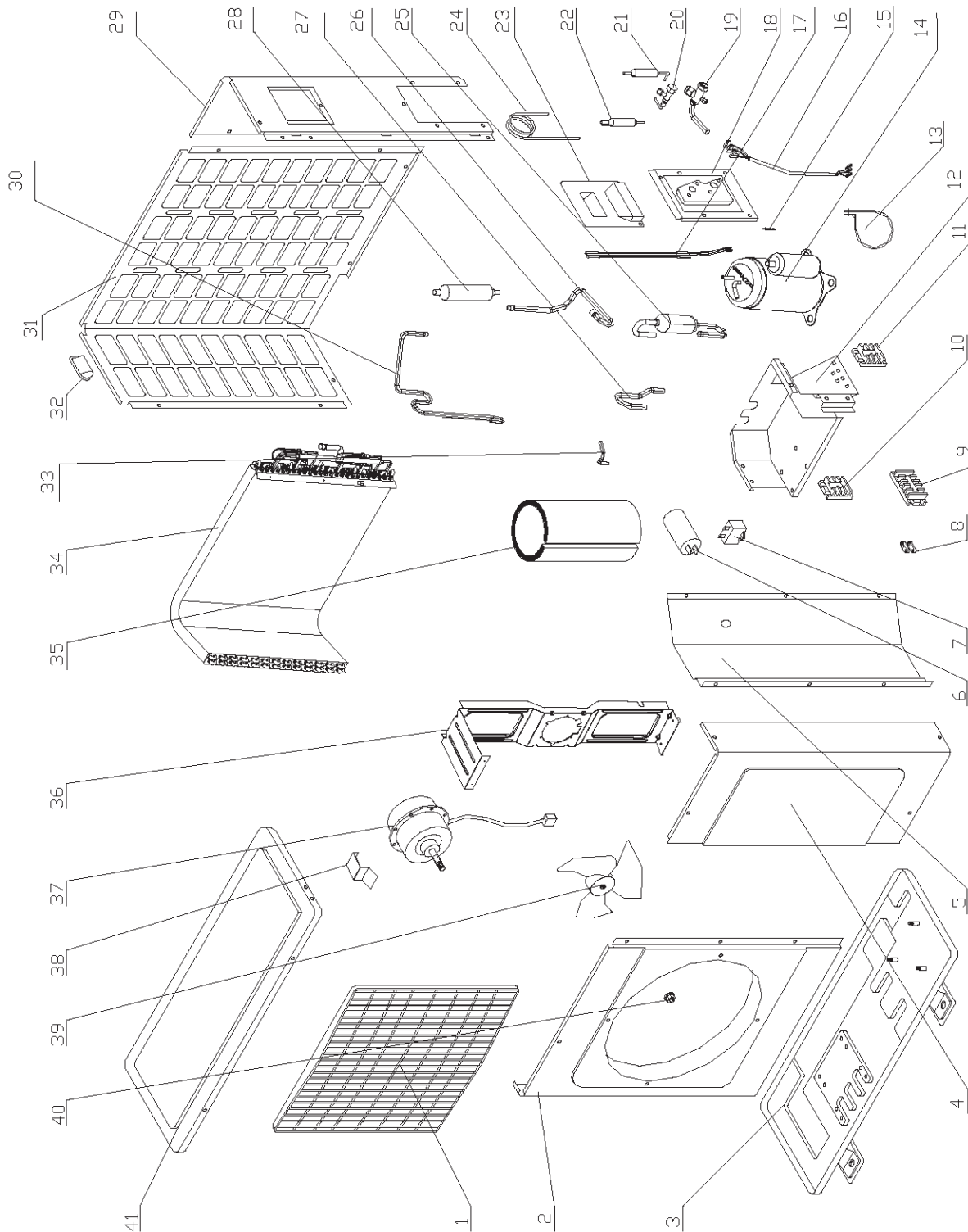

14.12 Outdoor Unit: GC 24 ST

No	Part No	Description	Qty
1	4517144	FAN COVER PP+UV	1
2	452795700	PAINTED LEFT CABINET ASSY	1
3	452881901	Base plate paint assy.	1
4	4516786	PAINTED RIGHT CABINET ASSY	1
5	4516985	Partition Plate	1
6	455000301	Compressor Capacitor 55uF (CBB65)	1
7	455000104	Double patch Capacitor for fan	1
8	204107	Cable clip Nylon	2
9	4522469	4 LEVEL TERMINAL BLOCK	1
10	4521744	3 Poles Terminal Block (4mm ²)	1
11	4521733	3 Poles Terminal Block (6mm ²)	1
12	4521340	Controller Box	1
13	4525427	(d=50) clip for capacitance	1
14	452864700	Compressor NN27VBAMT assy. for	1
15	4519000	Spring fo compressor heater	1
16	4517345	COMPRESSOR WIRE ASSY. 2.5mm ²	1
17	452892100	Heater for compressor	1
18	4516766	PAINTED VALVE PLATE ASSY	1
19	4526513	LOW PRESS VALVE (R410A)	1
20	4526514	Hight press valve(R410A)	1
21	452891100	Filter assy 1	1
22	452891200	Filter assy 2	1
23	4523145	R.lifter	1
24	452901200	Capillary welding assy.	1
25	452891400	Accumulation assy	1
26	452893600	Suction pipe	1
27	452883600	Suction pipe assy. 2	1
28	4526291	Muffler	1
29	4525938	PAINTED RIGHT-BACK CABINET ASSY	1
30	452893700	Discharge tube 1	1
31	4517028	PAINTED LEFT-BACK GRILL	1
32	4516758	SMALL HANDLE	1
33	452893800	Discharge pipe 2	1
34	452882900	Condenser and distributor	1
35	452891300	Insulation for compressor NN27	1
36	4526509	MOTOR BRAKECT (new)	1
37	4526864	motor YYK85E-6	1
38	452907400	Hook for condenser	1
39	4526510	FAN D=460mm (3 blade)	1
40	4523141	M10 Hexagon locked nut M10	1
41	4516788	PAINTED TOP COVER ASSY	1

14.13 Outdoor Unit GC 24 RC

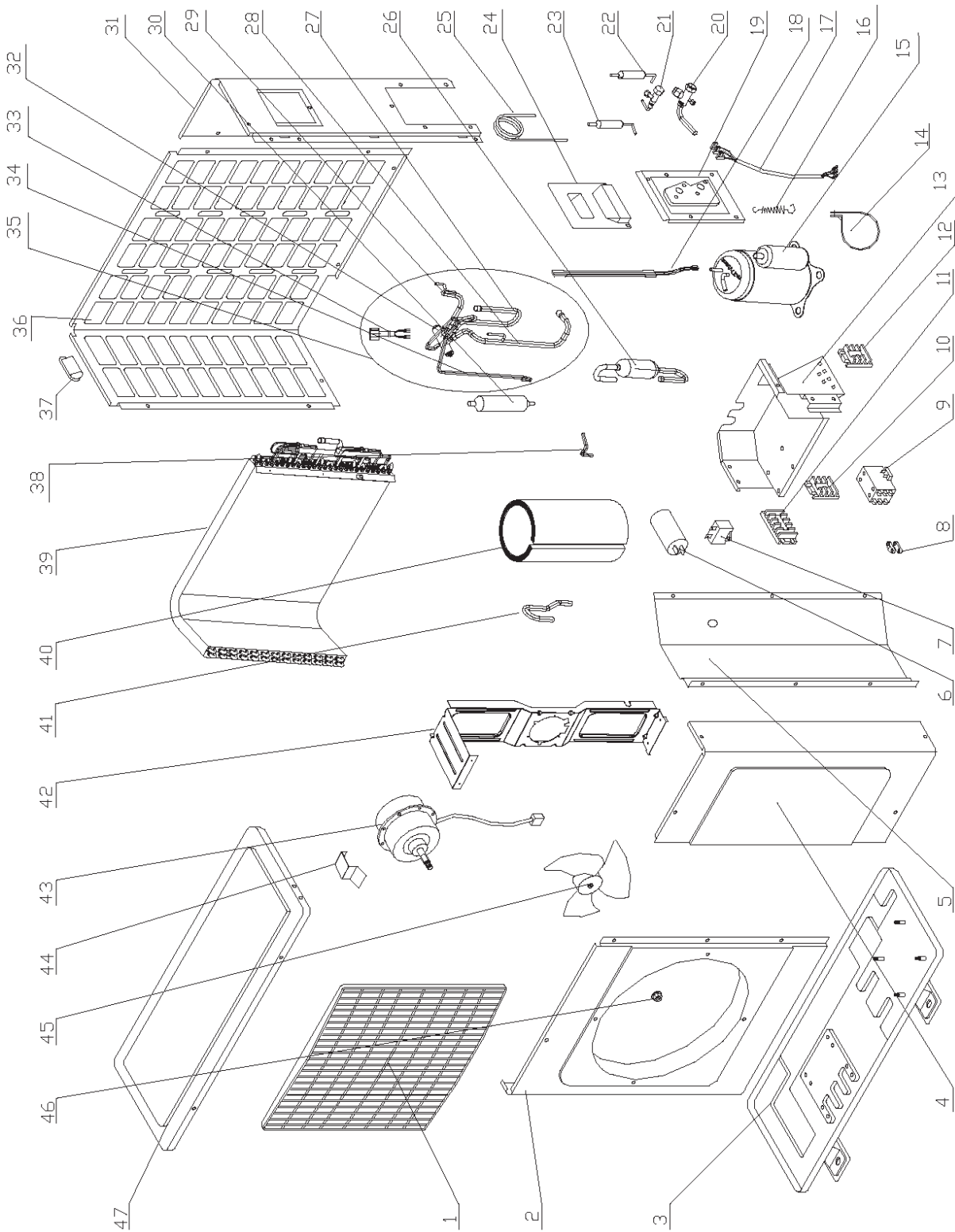

14.14 Outdoor Unit: GC 24 RC

No	Part No	Description	Qty
1	4517144	FAN COVER PP+UV	1
2	452795700	PAINTED LEFT CABINET ASSY	1
3	452881901	Base plate paint assy.	1
4	4516786	PAINTED RIGHT CABINET ASSY	1
5	4516985	Partition Plate	1
6	455000301	Compressor Capacitor 55uF (CBB65)	1
7	455000104	Double patch Capacitor for fan	1
8	204107	Cable clip Nylon	2
9	4524907	contactor (CJX9B-25S/01)	1
10	4521744	3 Poles Terminal Block (4mm ²)	1
11	4522469	4 LEVEL TERMINAL BLOCK	1
12	4521733	3 Poles Terminal Block (6mm ²)	1
13	4521340	Controller Box	1
14	4525427	(d=50) clip for capacitance	1
15	452864700	Compressor NN27VBAMT assy. for	1
16	4519000	Spring fo compressor heater	1
17	4517345	COMPRESSOR WIRE ASSY. 2.5mm ²	1
18	452862100	Base Bom for KCR-50M(SHX33SC4-U	1
18	452892100	Heater for compressor	1
19	4516766	PAINTED VALVE PLATE ASSY	1
20	4526513	LOW PRESS VALVE (R410A)	1
21	4526514	Hight press valve(R410A)	1
22	452891100	Filter assy 1	1
23	452891200	Filter assy 2	1
24	4523145	R.lifter	1
25	452891600	Single-way welding assy	1
26	452891400	Accumulation assy	1
27	452883700	Suction pipe	1
28	452883800	Low pressure pipe assy.	1
29	452883500	Condenser pipeassy.	1
30	4526291	Muffler	1
31	4525938	PAINTED RIGHT-BACK CABINET ASSY	1
32	4526522	FOUR-WAY VALVE R410A	1
33	4526589	4-Way Valve Coil FOR R410A	1
34	452890700	Dischage pipe 1	1
35	452882800	4-way welding assy.	1
36	4517028	PAINTED LEFT-BACK GRILL	1
37	4516758	SMALL HANDLE	1
38	452890800	Discharge tube 2	1
39	452882900	Condenser and distributor	1
40	452891300	Insulation for compressor NN27	1
41	452883600	Suction pipe assy. 2	1
42	4526509	MOTOR BRAKECT (new)	1
43	4526864	motor YYK85E-6	1
44	452907400	Hook for condenser	1
45	4526510	FAN D=460mm (3 blade)	1
46	4523141	M10 Hexagon locked nut M10	1
47	4516788	PAINTED TOP COVER ASSY	1
48	452925700	Pressure switch 4.2MPa/3.7MPa	1
49	192106	Relay JQX-13F/220-2Z5 OR VE-R02 2Ca2	1

14.15 Outdoor Unit: OU7-24 RC 1PH

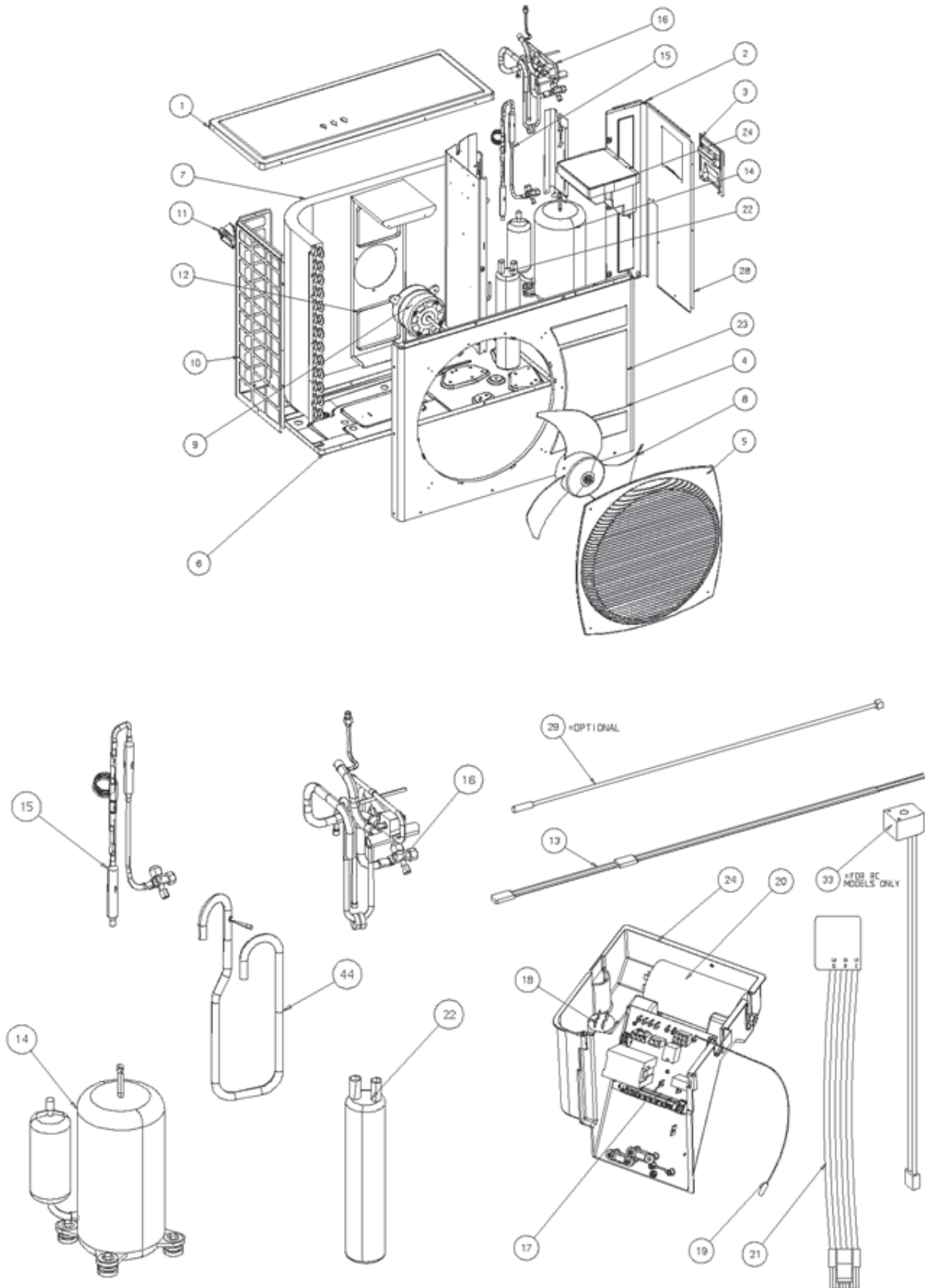

14.16 Outdoor Unit: OU7-24 RC 1PH

No	Part No	Description	Qty
1	437045	UPPER COVER EL13 OU LARGE	1
2	433280	SIDE PANEL OU7-24 R410A	1
3	436357	SMALL ELECTRICAL COVER OU	1
4	439329	FRONT COVER/CO' OU7-35/90 E	1
5	437091	OU SQUARE FAN GUARD	1
6	433705	NEW BASE ASSY OU 2005 LOCAL	1
7	433285	COIL OU7-24 HDR	1
8	4529604	AXIAL FAN D493*143	1
9	434062	MOTOR 86W,2S,OU7-24	1
10	433281	SIDE GUARD OU7-24 R410	1
11	436358	OU LEADING HANDLE	1
12	439342	MOTOR SUPPORT OU7-24	1
13	190443	HEATER CRANKCASE MITSUBISHI	1
14	433293	COMPRESSOR NN27VBAMT	1
15	433934	CAPILLARY HEATING ASSY OU7-24	1
16	433291	TUBING ASSY OU7 R410A	1
17	402495	BOARD TPHN 5B	1
18	442007	CAPACITOR 6mF 400V P1/P2	1
19	434716	THERMISTOR+CAP WTH CONNECTO	1
20	442011	CAPACITOR 25mF 400V P1/P2	1
20	442016	CAPACITOR 55mF 400V P1/P2	1
21	437274	COMPRESOR WIRING OU7/8-1PH	1
22	402283	SUCTION ACCUMULATOR 3x5/8"	1
24	437229	ELECTRICAL BOX TPHN	1
33	442466	VALVE COIL L700 MOLEX-SANHU	1
44	433816	SUCTION ASSY OU7 R410A	1

14.18 Outdoor Unit: OU7-24 ST 1PH

No	Part No	Description	Qty
1	437045	UPPER COVER EL13 OU LARGE	1
2	433280	SIDE PANEL OU7-24 R410A	1
3	436357	SMALL ELECTRICAL COVER OU	1
4	439329	FRONT COVER/CO' OU7-35/90 EL13	1
5	437091	OU SQUARE FAN GUARD	1
6	433705	NEW BASE ASSY OU 2005 LOCAL R4	1
7	433846	COIL OU7-24 ST	1
8	4529604	AXIAL FAN D493*143	1
9	434062	MOTOR 86W,2S,OU7-24	1
10	433281	SIDE GUARD OU7-24 R410	1
11	436358	OU LEADING HANDLE	1
12	439342	MOTOR SUPPORT OU7	1
13	190443	HEATER CRANKCASE MITSUBISHI CO	1
14	433293	COMPRESSOR NN27VBAMT	1
15	433845	CAPILLARY ASSY OU7-24 ST R410A	1
16	433817	TUBING ASSY OU7 ST R410A	1
17	402495	BOARD TPHN 5B	1
18	442007	CAPACITOR 6mF 400V P1/P2	1
19	434716	THERMISTOR+CAP WTH CONNECTOR L	1
20	442016	CAPACITOR 55mF 400V P1/P2	1
21	437274	COMPRESOR WIRING OU7/8-1PH MIT	1
22	402283	SUCTION ACCUMULATOR 3x5/8" 3. "	1
24	437229	ELECTRICAL BOX TPHN	1
44	433816	SUCTION ASSY OU7 R410A	1
45	433847	GAS VAVE ASSY OU7 ST R410A	1

14.19 Outdoor Unit: OU7-24Z RC/ST 1PH

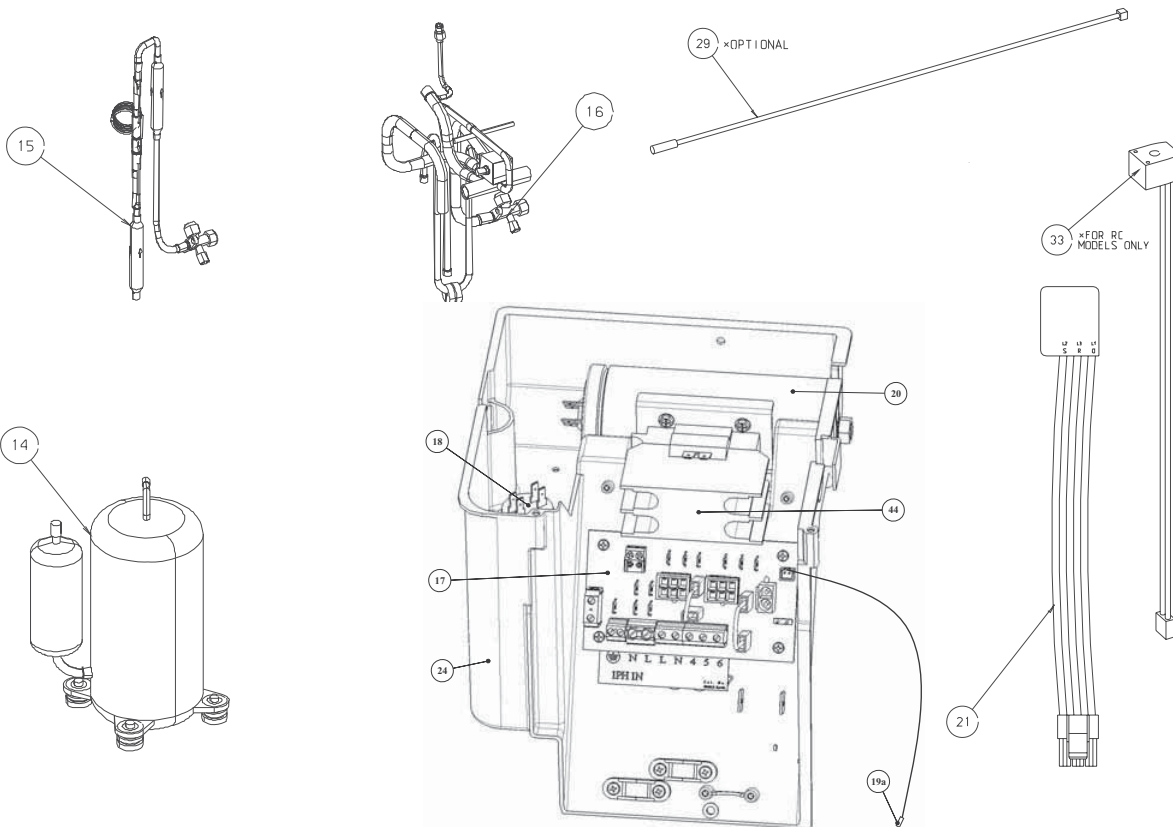
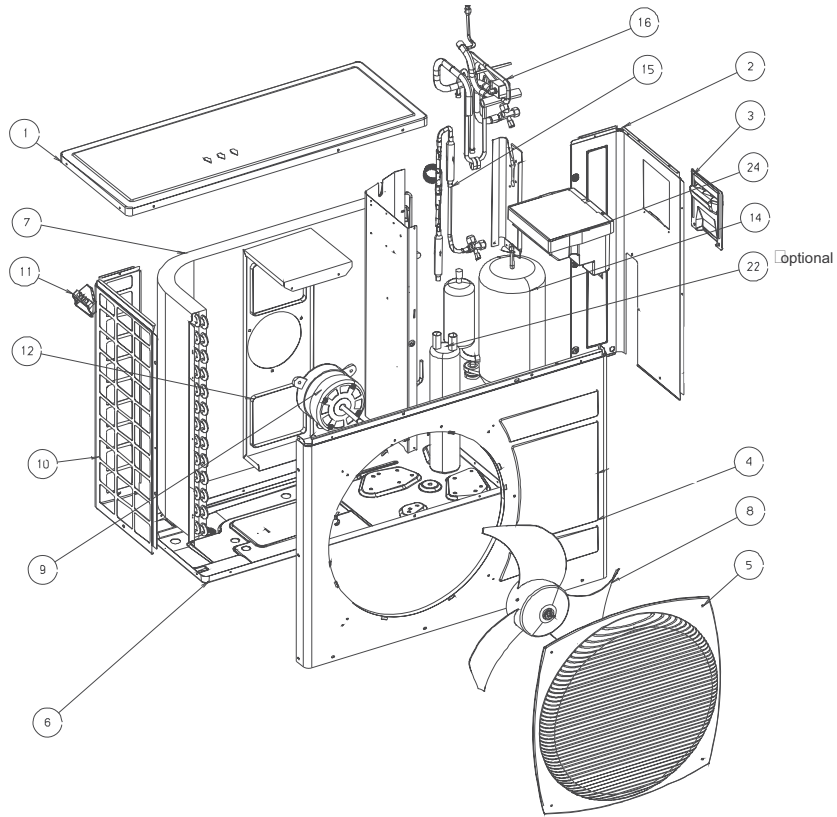

14.20 Outdoor Unit: OU7-24Z RC/ST 1PH

No	PartNo	Description	Qty
1	437045	LARGE UPPER COVER CUE	1
2	433280	SIDE PANEL OU7-24 R410A	1
3	436357	SMALL ELECTRICAL COVER CUE	1
4	439329	COVERAIR COLLECTOR	1
5	437091	OU SQUARE FAN GUARD	1
6	433722	BASE ASSY OU7-24C EXPORT R410A	1
7	433285	COIL OU7-24 HDR	1
8	4529604	AXIAL FAN D493x143	1
9	434211	Replace by SP000000266 MOTOR+BRACKET	1
10	433281	SIDE GUARD OU7-24 R410	1
11	436358	TRANSPORT HANDLE CUE	1
12	439342	MOTOR BASE OU7	1
14	438795	COMPRESSOR GP270PAA	1
15	433934	CAPILLARY HEATING ASSY OU7-24 R410A	1
16	433660	TUBING ASSY OU7-24C R410A	1
17	413496	BOARD TPHN 5F (RoHS)	1
18	442007	CAPACITOR 6uF 400V	1
19a	434716	THERMISTOR L1050 (for coil)	1
20	442038	CAPACITOR 50mF 400V P1/P2	1
21	438627	COMPRESSOR WIRING TPHN-5F	1
24	437229	ELECTRICAL BOX TPHN	1
33	442520	VALVE COIL L700 MOLEX-DUNAN	1
44	192207	CONTACTOR 230V, 40A	1

14.21 Outdoor Unit: OU7-24 RC 3PH

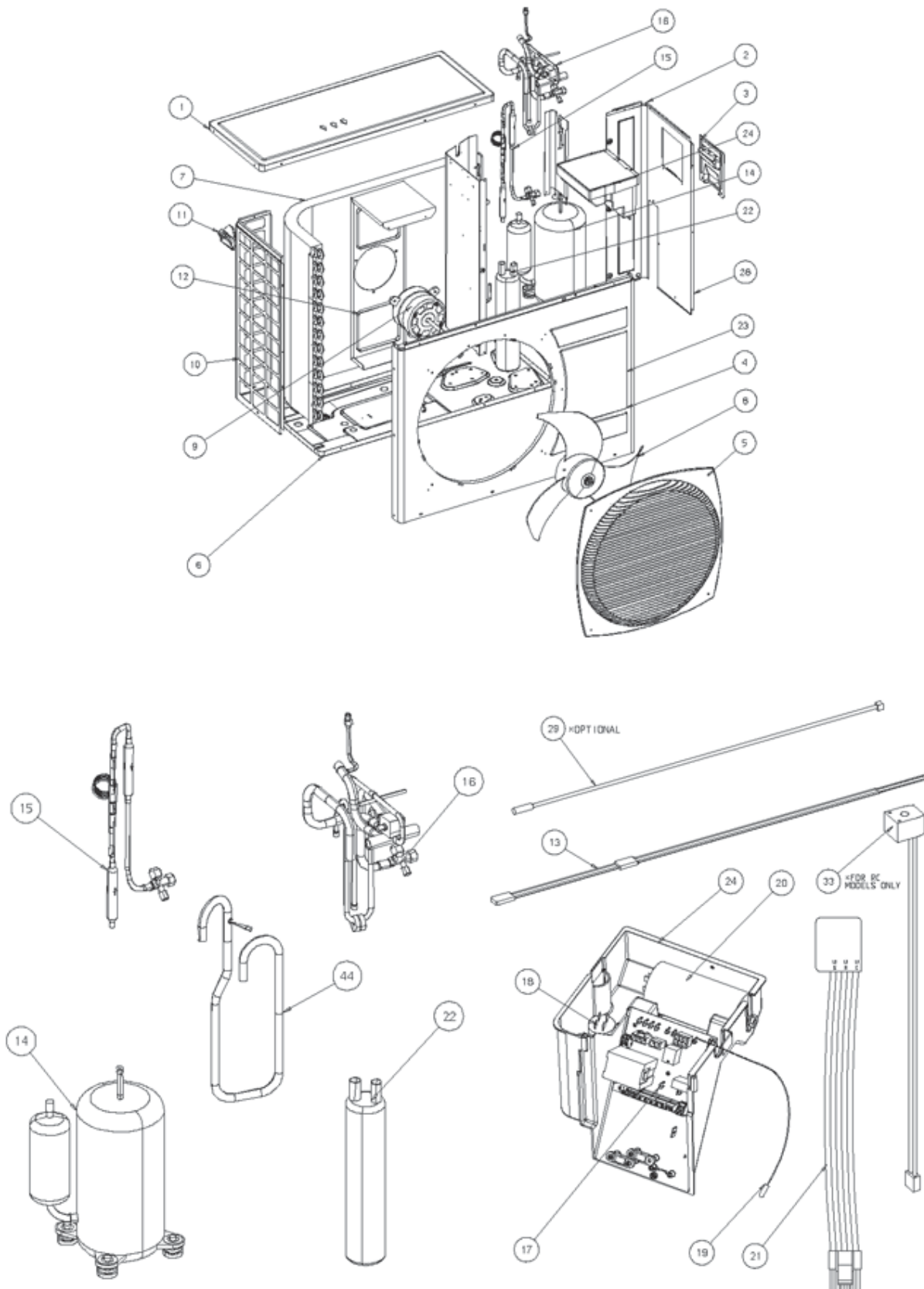

14.22 Outdoor Unit: OU7-24 RC 3PH

No	Part No	Description	Qty
1	437045	UPPER COVER EL13 OU LARGE	1
2	433280	SIDE PANEL OU7-24 R410A	1
3	436357	SMALL ELECTRICAL COVER OU	1
4	439329	FRONT COVER/CO' OU7-35/90 EL13	1
5	437091	OU SQUARE FAN GUARD	1
6	433294	NEW BASE ASSY OU 2005 EXPORT R	1
7	433285	COIL OU7-24 HDR	1
8	4529604	AXIAL FAN D493*143	1
9	434062	MOTOR 86W,2S,OU7-24	1
10	433281	SIDE GUARD OU7-24 R410	1
11	436358	OU LEADING HANDLE	1
12	439342	MOTOR SUPPORT OU7	1
13	190443	HEATER CRANKCASE MITSUBISHI CO	1
14	433753	COMPRESSOR NN27YDAMT	1
15	433934	CAPILLARY HEATING ASSY OU7-24	1
16	433291	TUBING ASSY OU7 R410A	1
17	402494	BOARD TPHN 3C	1
18	442007	CAPACITOR 6mF 400V P1/P2	1
19	434716	THERMISTOR+CAP WTH CONNECTOR L	1
21	437278	COMPRESSOR WIRING OU7/8-3PH MI	1
22	402283	SUCTION ACCUMULATOR 3x5/8" 3. "	1
24	437229	ELECTRICAL BOX TPHN	1
25	439795	3PH MOTOR PROTECTOR	1
33	442466	VALVE COIL L700 MOLEX-SANHUA	1
44	433816	SUCTION ASSY OU7 R410A	1

14.23 Outdoor Unit: OU7-24 ST 3PH

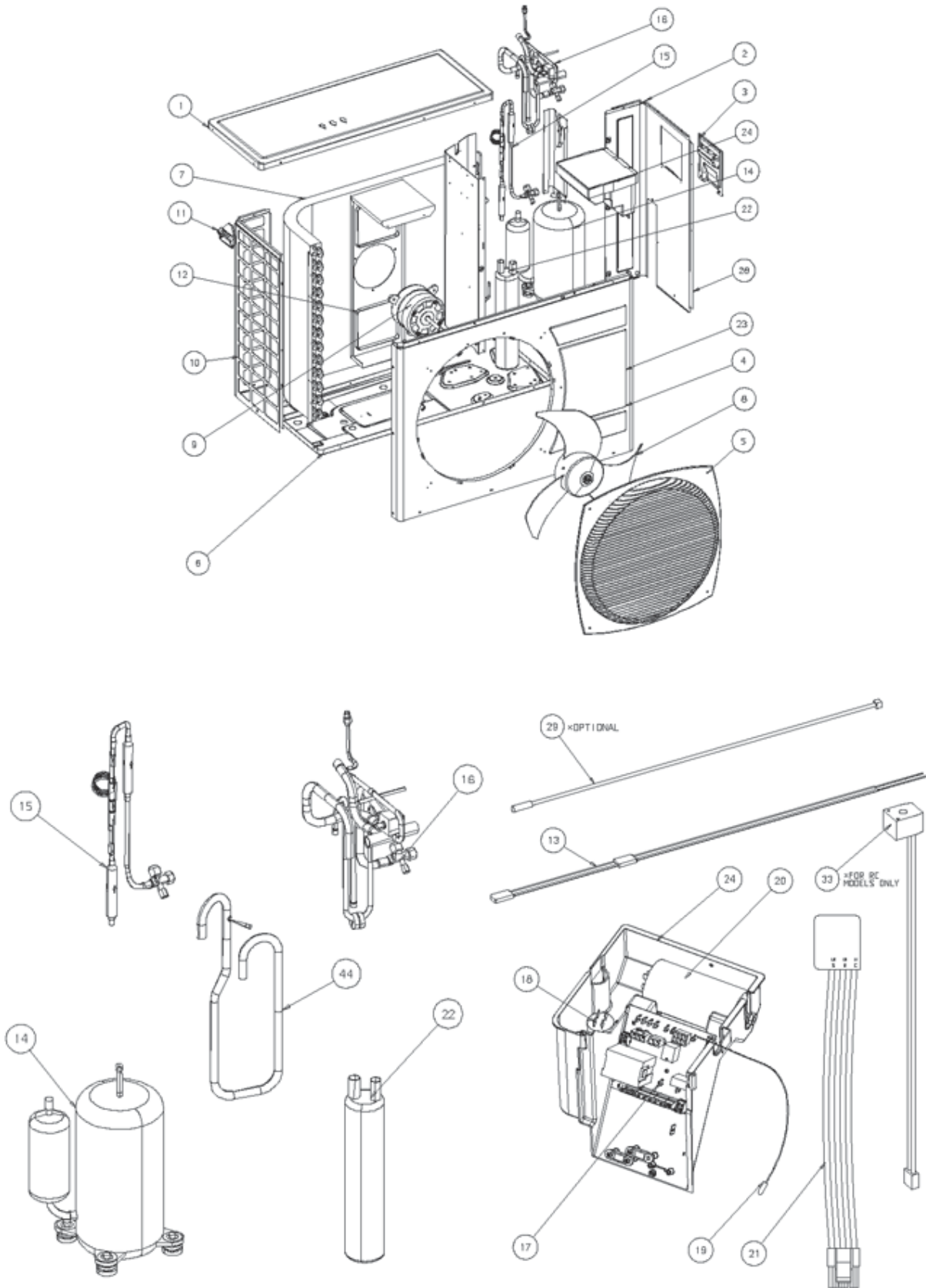

14.24 Outdoor Unit: OU7-24 ST 3PH

No	Part No	Description	Qty
1	437045	UPPER COVER EL13 OU LARGE	1
2	433280	SIDE PANEL OU7-24 R410A	1
3	436357	SMALL ELECTRICAL COVER OU	1
4	439329	FRONT COVER/CO' OU7-35/90 EL13	1
5	437091	OU SQUARE FAN GUARD	1
6	433705	NEW BASE ASSY OU 2005 LOCAL R4	1
7	433846	COIL OU7-24 ST	1
8	4529604	AXIAL FAN D493*143	1
9	434062	MOTOR 86W,2S,OU7-24	1
10	433281	SIDE GUARD OU7-24 R410	1
11	436358	OU LEADING HANDLE	1
12	439342	MOTOR SUPPORT OU7	1
13	190443	HEATER CRANKCASE MITSUBISHI CO	1
14	433753	COMPRESSOR NN27YDAMT	1
15	433845	CAPILLARY ASSY OU7-24 ST R410A	1
16	433817	TUBING ASSY OU7 ST R410A	1
17	402494	BOARD TPHN 3C	1
18	442007	CAPACITOR 6mF 400V P1/P2	1
19	434716	THERMISTOR+CAP WTH CONNECTOR L	1
21	437278	COMPRESSOR WIRING OU7/8-3PH MI	1
22	402283	SUCTION ACCUMULATOR 3x5/8" 3. "	1
24	437229	ELECTRICAL BOX TPHN	1
25	439795	3PH MOTOR PROTECTOR	1
44	433816	SUCTION ASSY OU7 R410A	1
45	433847	GAS VAVE ASSY OU7 ST R410A	1

15. OPTIONAL ACCESSORIES

15.1 RCW Wall Mounted Remote Control

15.1.1 The RCW wall mounted remote control can be fitted to a large range and models, It can be used as IR (wireless mode) or wired controller. the RCW can control up to 15 indoor units using the same settings (on its wired application),

The max wiring length between the controller to the last indoor unit is 300m. for application on WNG LED indoor units an additional interface PCB is needed.

Ordering code no':

RCW – 436195
WNG add' PCB - SP000000290.

REMOTE CONTROL

1. START / STOP button
2. Operation mode selection button COOLING, HEATING, AUTO COOL / HEAT, DRY, FAN.
3. LOCAL temperature sensing button
4. FAN SPEED and AUTO FAN button
5. Room temperature UP button
6. Room temperature DOWN Button
7. NIGHT button
8. Airflow direction MANUAL positioning control button
9. Airflow direction AUTO-CONTROL button
10. TIMER button
11. TIMER UP button
12. TIMER DOWN button
13. LCD operation display
14. LOCAL sensor
15. Infrared signal transmitter
16. ROOM temperature button
17. TIMER SET button
18. TIMER CLEAR button
19. Transmission sign

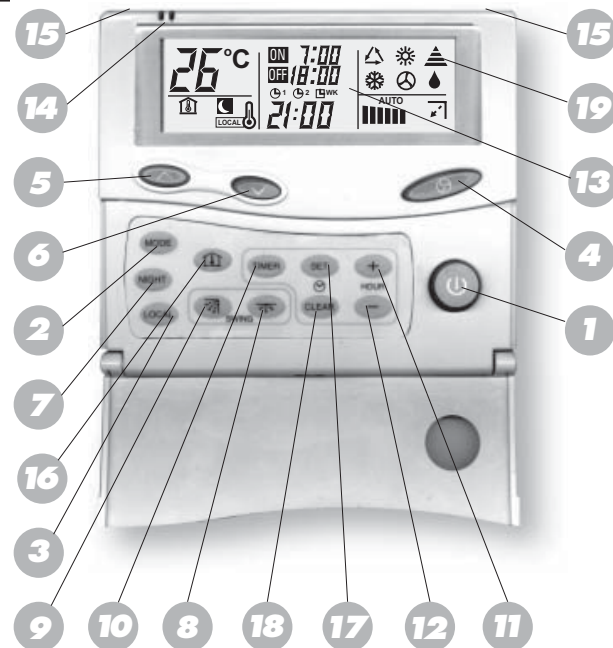

15.2 RCW2 Wall Mounted Remote Control

15.2.1 The RCW2 wall mounted remote controller is a wired controller that can provide effective controlling management up to 15 different settings and temp' zones.

The RCW2 can be connected up to a max' of 32 units, allowing a max wiring length of 1000m. for application on WNG LED indoor units an additional interface PCB is needed.

Ordering code no':

RCW2 – SP000000081
WNG add' PCB - SP000000290

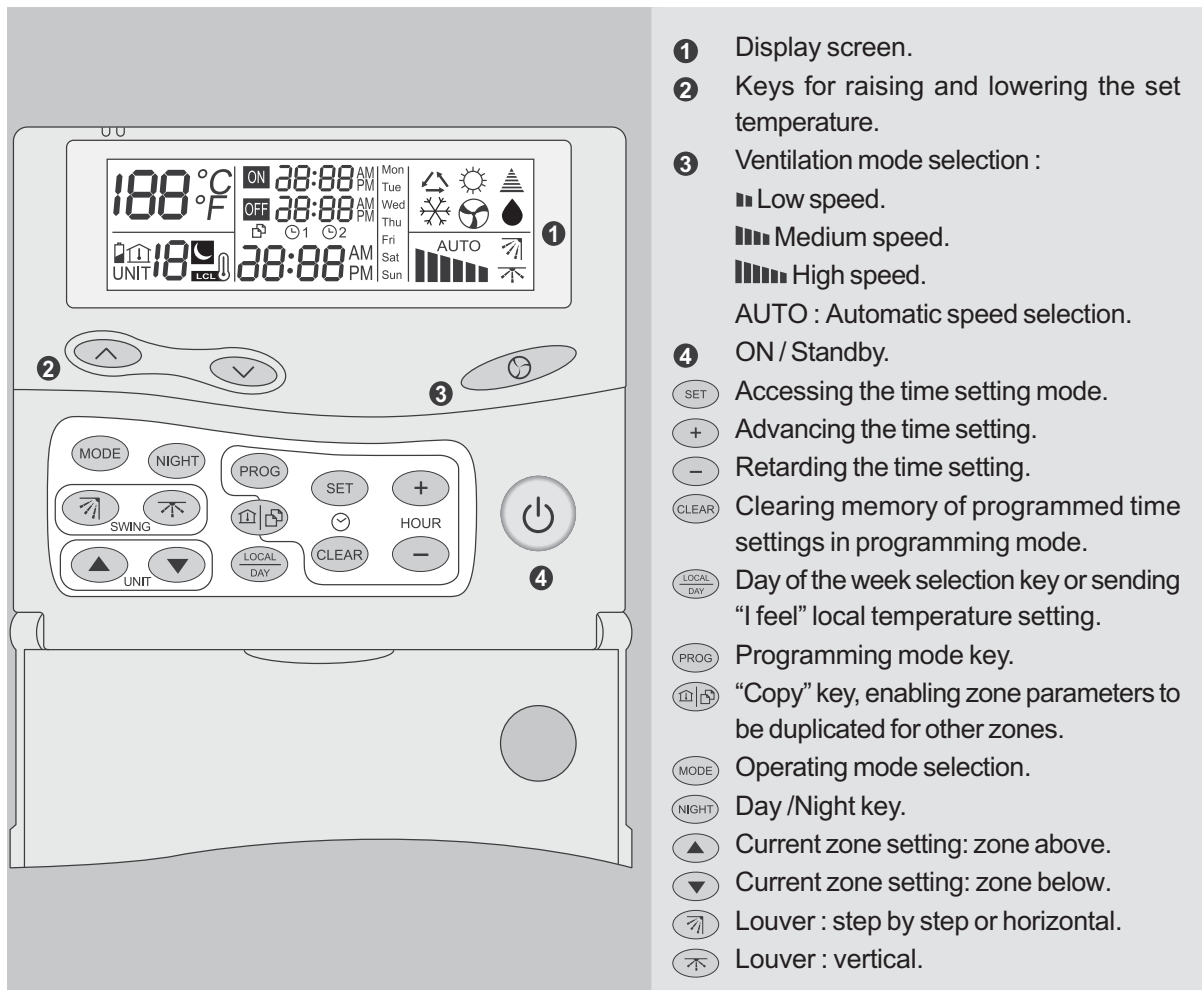

- 1** Display screen.
- 2** Keys for raising and lowering the set temperature.
- 3** Ventilation mode selection :
 - ▄ Low speed.
 - ▄▄ Medium speed.
 - ▄▄▄ High speed.
 - AUTO : Automatic speed selection.
- 4** ON / Standby.
- (SET) Accessing the time setting mode.
- (+) Advancing the time setting.
- (-) Retarding the time setting.
- (CLEAR) Clearing memory of programmed time settings in programming mode.
- (LOCAL DAY) Day of the week selection key or sending "I feel" local temperature setting.
- (PROG) Programming mode key.
- (COPY) "Copy" key, enabling zone parameters to be duplicated for other zones.
- (MODE) Operating mode selection.
- (NIGHT) Day /Night key.
- (▲) Current zone setting: zone above.
- (▼) Current zone setting: zone below.
- (SWING) Louver : step by step or horizontal.
- (VERTICAL) Louver : vertical.

15.3 A.S.K (All Season Kit)

The A.S.K is a pressure regulator to be installed on site in case the working conditions are below the standard operating range of the unit in cooling mode.

The ASK allows working in cooling at low temp' up to -10 °C for rooms with high internal gains.

For units up to 7.2 KW kit code no' – 7ACFH0077

For units up to 12 KW kit code no' – 7ACFH0078

Documentation as shown on kits :

TH 2210 H - 398887

Climatiseurs individuels "Split System" Standard (GC 9-11-12-15-18-24-28F)
Standard split-system individual air-conditioning units (GC 9-11-12-15-18-24-28F)
Split-raumklimageräte in standardausführung (GC 9-11-12-15-18-24-28F)

Montage du kit toutes saisons électronique code 680480
kit installation : Electronic Around the Year code 680480

Elektronischer Bausatz für alle Jahreszeiten 680480

Mise hors tension de l'appareil

! Switch off power supply to the unit

- Fig.1 Déposer :
- Le couvercle A
- Fig.2 Fixer le pressostat C sur le support fourni avec les 2 vis fournies
- Fixer l'ensemble sur la cloison du compartiment compresseur avec la vis autopercutée fournie.
- Dévisser le bouchon de la valve D en attente, et raccorder l'extrémité E du capillaire du pressostat C.
- Fig.3 - Fixer le pressostat C sur la cloison du compartiment compresseur dans les 2 trous prévus, avec les 2 vis fournies.
- Dévisser le bouchon de la valve D en attente, et raccorder l'extrémité E du capillaire du pressostat C.

Mise hors tension de l'appareil

! Switch off power supply to the unit

- Fig.1 Remove :
- Cover A
- Fig.2 Mount pressure switch C on the provided support, using the two screws supplied.
- Mount the unit on the partition of the compressor compartment, using the self-drilling screw supplied.
- Unscrew the cap of valve D provided and connect the end E of pressure switch C capillary line to it.
- Fig.3 - Mount pressure switch C on the partition of the compressor compartment in the holes provided, using the two screws supplied.
- Unscrew the cap of valve D provided and connect the end E of pressure switch C capillary line to it.

Das Gerät außer Spannung setzen

! Switch off power supply to the unit

- Abb.1 Abnehmen :
- Haube A
- Abb.2 Pressostat C mit Hilfe der 2 mitgelieferten Schrauben auf dem gelieferten Träger befestigen.
- Die Maßeinheit mit Hilfe die Schraube in der Wand des Kompressorraums befestigen.
- Das anschlussfertige Ventil D nach Abnehmen des Stopfens an das Ende E des Kapillarrohrs von Pressostat C anschließen.
- Abb.3 - Pressostat C mit Hilfe der 2 mitgelieferten Schrauben in den zwei in der Wand des Kompressorraums befindlichen Löchern befestigen. Das anschlussfertige Ventil D nach Abnehmen des Stopfens an das Ende E des Kapillarrohrs von Pressostat C anschließen.

Remarque :
Le té fourni dans le kit peut être installé entre la valve D et le capillaire E. Il permet de disposer d'une prise de pression supplémentaire.

Hinweis:
Das in dem Bausatz mitgelieferte T-Profil kann zwischen dem Ventil D und dem Kapillarrohr E installiert werden. Dadurch sieht eine zusätzliche Druckanschlusstelle zur Verfügung.

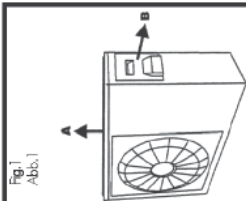

Fig.1
Abb.1

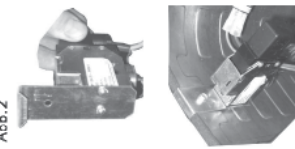

Fig.2
Abb.2

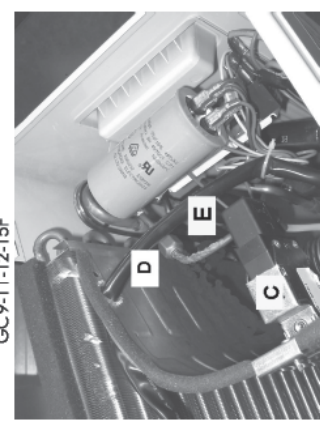
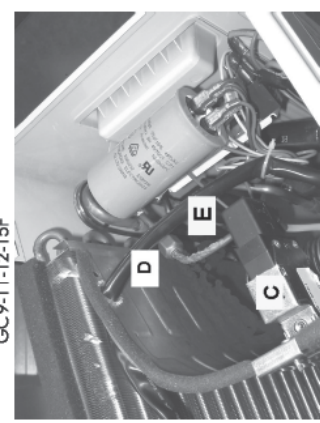
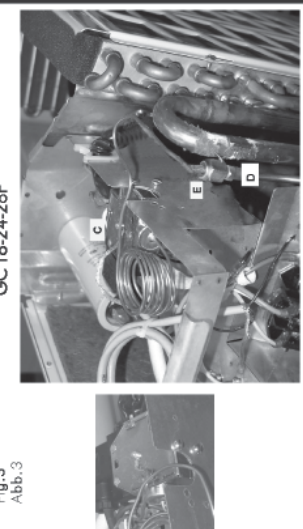

Fig.3
Abb.3



GC 9-11-12-15F



GC 18-24-28F

Climatiseurs individuels *Split System* Standard (GC 9-11-12-15-18-24-28F)
 Standard split-system individual air-conditioning units (GC 9-11-12-15-18-24-28F)
 Split-raumklimageräte in standardausführung (GC 9-11-12-15-18-24-28F)

- Fig. 4
Raccordement électrique
- Déconnecter le fil du moteur de ventilation de la borne 6.
- Raccorder le fil noir du pressostat sur la borne 6 libéré précédemment.
- Raccorder l'autre fil noir du pressostat sur le fil du moteur ventilation déconnecté précédemment à l'aide du connecteur m-à-m-à fourni.
- Raccorder la tresse de masse.
- Remonter les éléments démontés précédemment.

- Fig. 4
Electrical connections
- Disconnect the wire of fan motor on terminal 6.
- Connect a black wire of the pressure controller with terminal 6 previously made available.
- Connect the other black wire of the pressure controller with the wire of the fan motor previously disconnected by means of the provided male-male connector.
- Connect the grounding braid.
- Re-assemble the previously removed element.

- Abb. 4
Elektrische Anschlüsse
- Den Draht des Belüftungsmotors der Klemme 6 freilegen.
- Eine schwarzen Draht des Druckreglers mit der vorher freigelegten Klemme 6 verbinden.
- Den anderen Draht des Druckreglers mit Hilfe des mitgelieferten Steckverbinders mit dem vorher abgeklemmten schwarzen Draht des Belüftungsmotors verbinden. Die Massenslitze anschließen.
- Die vorher demontierten Elemente wieder montieren.

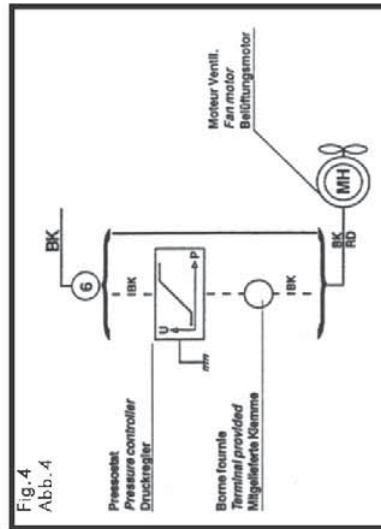

Fig. 4
Abb. 4

GC18-24-28F

MS 1040F (N° de produit fini : 7SP091012A) - MS 1400F (N° de produit fini : 7SP091014A / 7SP091015A)
 MS 1040F (End product part numbers : 7SP091012A) - MS 1400F (End product part numbers : 7SP091014A / 7SP091015A)
 MS 1040F (Teilenummern der enderzeugnisse : 7SP091012A) - MS 1400F (Teilenummern der enderzeugnisse : 7SP091014A / 7SP091015A)



**Montage du kit toutes saisons
 électronique code 680480**

**kit installation : Electronic
 Around the Year code 680480**

**Elektronischer Bausatz für
 alle Jahreszeiten 680480**



Mise hors tension de l'appareil



Switch off power supply to the unit



Das Gerät außer Spannung setzen

• Fig. 4

Déposer :

- Le panneau de dessus rep. 1
- Le panneau avant rep. 2
- La grille avant rep. 3

• Fig. 4

Remove :

- Top panel / labeled 1
- Front panel / labeled 2
- Front grille / labeled 3

• Abb. 4

Abnehmen :

- Das obere Panel Kennz. 1
- Das Frontpanel Kennz. 2
- Das vordere Gitter Kennz. 3

• Fig. 5

Fixer le thermostat C sur la platine électrique

- en position Haute pour le groupe 2
- en position Basse pour le groupe 1

• Fig. 5

Fix thermostat C on the electric panel

- in position High for group 2
- in position Low for group 1

• Abb. 5

Das Thermostat C auf der Stromplatine befestigen

- in oberer Position für die Gruppe 2
- in unterer Position für die Gruppe 1

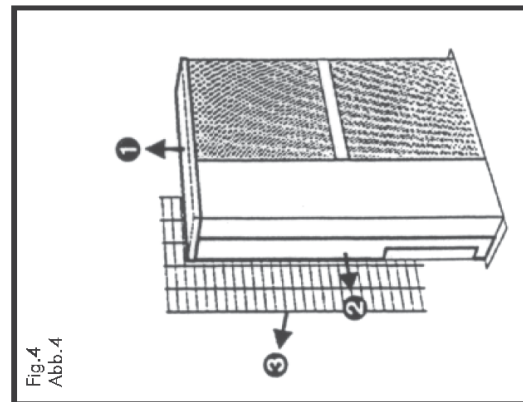

Fig. 4
Abb. 4

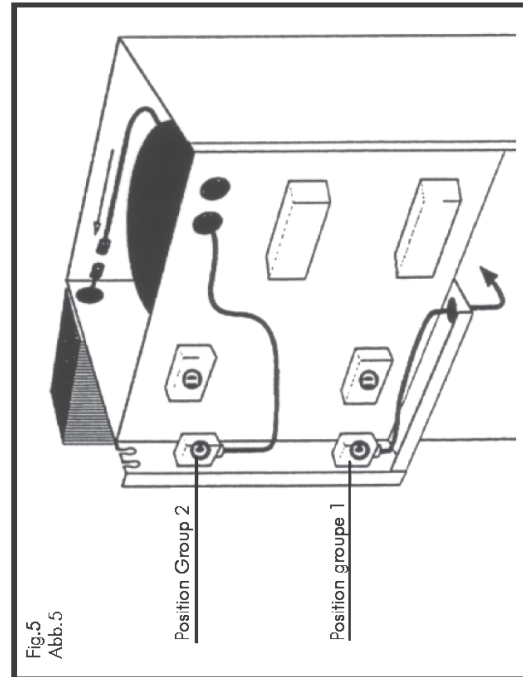

Fig. 5
Abb. 5

Fig. 6
Abb.6

- Raccorder l'extrémité des capillaires des pressostat C sur les VUS correspondantes.

Remarque :
Le té fourni dans le kit peut être installé entre la valve et le capillaire. Il permet de disposer d'une prise de pression supplémentaire.

Fig. 7

- Raccordement électriques
- Déconnecter le fil Noir du moteur de ventilation de la borne 11 (Bornter rep.D fig.5) du groupe 1 ou 2, concerné par le montage du kit.
- Raccorder un fil Noir du pressostat sur la borne 11 libéré précédemment.
- Raccorder l'autre fil Noir du pressostat sur le fil Noir du moteur déconnecté précédemment à l'aide du connecteur mâle-mâle fourni.
- Raccorder la tresse de masse.

Fig. 6
Abb.6

- Connect the end of the capillaries of pressure controller C with the corresponding VUS.

Comment:
The « T » supplied in the kit can be installed between the valve and the capillary. It offers the possibility of having an additional pressure outlet.

Fig. 7

- Electric connections
- Disconnect the Black wire of fanmotor on terminal 11 (terminal block labeled D fig.5) of group 1 or 2 according to the group concerned.
- Connect a Black wire of the pressure controller with terminal 11 previously made available.
- Connect the other Black wire of the pressure controller with the Black wire of the fanmotor previously disconnected by means of the provided male-male connector.
- Connect the grounding braid.

Fig. 6
Abb.6

Fig. 7
Abi

- Remonter les éléments démontés précédemment.

- Re-assemble the previously removed elements.

4/4

**GROUPE DE CONDENSATION (GC 30 F)
CONDENSER UNIT (GC 30F)
VERFLÜSSIGEREINHEIT (GC 30F)**

KIT TOUTES SAISONS ELECTRONIQUES (680488).

Montage du kit.

Groupe de condensation GC 30 F (Fig. 1).

Déposer :

- Le couvercle A.
- La trappe de raccordement électrique B.
- Le panneau de côté F.

Fixer le pressostat C sur la cloison du compartiment compresseur dans les 2 trous prévus, avec les 2 vis fournies. (Fig.2).

Dévisser le bouchon de la valve D en attente, et raccorder l'extrémité E du capillaire du pressostat C. (Fig.3).

Remarque :

Le té fourni dans le kit peut être installé entre la valve D et le capillaire E. Il permet de disposer d'une prise de pression supplémentaire.

Raccordements électriques. Sur le bornier de raccordement.

Déconnecter le fil noir (moteur) de la borne 6 du bornier de raccordement et le raccorder au connecteur avec le fil 2 du câble du pressostat.

Raccorder le 2^{ème} fil noir (marqué 1) du pressostat à la borne 6 du bornier de raccordement précédemment libérée.

Vérifier l'absence de fuite au niveau de la valve.

Remonter le panneau F, le couvercle A et la trappe B.

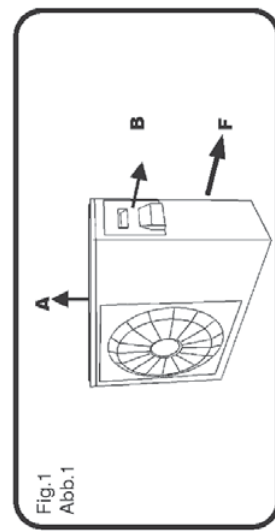

Fig.1
Abb.1

YEAR-ROUND SYSTEM ELECTRONIC KIT (680488).

Installation of the kit.

GC 30 F Condenser unit (Fig.1).

Remove :

- Cover A.
- Electrical connection hatch B
- Side panel F

Mount pressure switch C on the partition of the compressor compartment in the two holes provided, using the two screws supplied (Fig.2).

Unscrew the cap of valve D provided and connect the end E of pressure switch C capillary line to it (Fig.3).

Comment:

The «1» supplied in the kit can be installed between the valve D and the capillary E. It offers the possibility of having an additional pressure outlet.

Electrical connections. On the terminal board.

Disconnect the black wire (motor) from terminal 6 on the terminal board and connect it to the connector with the wire N°2 coming from the pressure switch.

Connect the second black wire (mark 1) of the pressure switch to terminal 6 on the terminal board that is now free.

Check that there is no leak in the valve.

Replace panel F, cover A and hatch B.

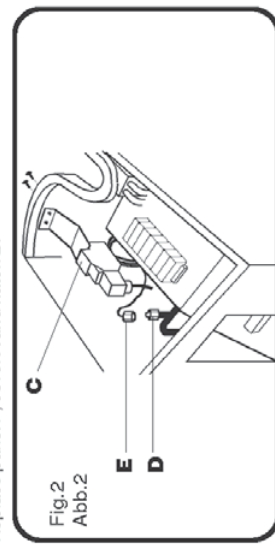

Fig.2
Abb.2

EINBAUSATZ ELEKTRONISCHE VERFLÜSSIGER-DRUCKREGELUNG (680488).

Einbau.

Am Verflüssigerteil GC 30 F (Fig.1) folgende Teile abnehmen :

- Haube A.
- Elektroanschlußklappe B
- Seitenpanel F

Pressostat C mit Hilfe der 2 mitgelieferten Schrauben in den zwei in der Wand des Kompressorraums befindlichen Löchern befestigen. (Fig.2).

Das anschlussfertige Ventil D nach Abnehmen des Stopfens an das Ende E des Kapillarrohrs von Pressostat C anschließen. (Fig.3).

Hinweis:

Das in dem Bausatz mitgelieferte T-Profil kann zwischen dem Ventil D und dem Kapillarrohr E installiert werden. Dadurch steht eine zusätzliche Druckanschlußsstelle zur Verfügung.

Elektrische Anschlüsse. An der Anschlußklemmleiste.

Das schwarze Kabel (Motor) von Klemme 6 der Anschlußklemmleiste abklemmen und an die Steckverbindung des von dem Pressostat kommenden Nr.2 Kabels anschließen.

Das 2. schwarze Kabel (1) des Pressostat an die zuvor freigewordene Klemme 6 der Anschlußklemmleiste anschließen.

Prüfen, daß an dem Ventil keine Leckage auftritt.

Seitenpanel F, Haube A und Klappe B wieder montieren.



TH 2531 D 399142

APPENDIX A

INSTALLATION AND OPERATION MANUAL

- ▶ **INSTALLATION AND OPERATION MANUAL DELTA 18, 21, 24**