

**SPLIT TYPE  
ROOM AIR CONDITIONER  
WALL MOUNTED<sup>type</sup>  
INVERTER**

# **SERVICE INSTRUCTION**

<b>Models</b>	<b>Indoor unit</b>	<b>Outdoor unit</b>
	ASYA07LCC	AOYR07LCC
	ASYA09LCC	AOYR09LCC
	ASYA12LCC	AOYR12LCC
	ASYA14LCC	AOYR14LCC
	ASYA18LCC	AOYR18LCC
	ASYB09LDC	AOYS09LDC
	ASYB12LDC	AOYS12LDC

*Refrigerant*  
**R410A**

# CONTENTS

## 1. SPECIFICATION

ASYA07/09LCC, AOYR07/09LCC.....	01-01
ASYA12/14/18LCC, AOYR12/14/18LCC.....	01-02
ASYB09/12LDC, AOYS09/12LDC.....	01-03

## 2. DIMENSIONS

ASYA07/09LCC, AOYR07/09LCC.....	02-01
ASYA12LCC, AOYR12LCC.....	02-02
ASYB09/12LDC, AOYS09/12LDC.....	02-03
ASYA14/18LCC, AOYR14/18LCC.....	02-04

## 3. REFRIGERANT SYSTEM DIAGRAM

ASYA07/09LCC, AOYR07/09LCC.....	03-01
ASYA12LCC, AOYR12LCC, ASYB09/12LDC, AOYS09/12LDC.....	03-02
ASYA14/18LCC, AOYR14/18LCC.....	03-03

## 4. CIRCUIT DIAGRAM

ASYA07/09LCC, AOYR07/09LCC.....	04-01
ASYA12LCC, AOYR12LCC.....	04-02
ASYB09/12LDC, AOYS09/12LDC.....	04-03
ASYA14/18LCC, AOYR14/18LCC.....	04-04

## 5. DESCRIPTION OF EACH CONTROL OPERATION

1. COOLING OPERATION.....	05-01
2. HEATING OPERATION.....	05-02
3. DRY OPERATION.....	05-03
4. AUTO CHANGEOVER OPERATION.....	05-04
5. INDOOR FAN CONTROL.....	05-05
6. OUTDOOR FAN CONTROL.....	05-07
7. LOUVER CONTROL.....	05-08
8. COMPRESSOR CONTROL.....	05-09
9. TIMER OPERATION CONTROL.....	05-10
10. ELECTRONIC EXPANSION VALVE CONTROL.....	05-12
11. TEST OPERATION CONTROL.....	05-12
12. PREVENT TO RESTART FOR 3 MINUTES ( 3 MINUTES ST ).....	05-12
13. FOUR-WAY VALVE EXTENSION SELECT.....	05-12
14. AUTO RESTART.....	05-12
15. MANUAL AUTO OPERATION ( Indoor unit body operation ).....	05-13
16. FORCED COOLING OPERATION.....	05-13
17. COMPRESSOR PREHEATING.....	05-13
18. COIL DRY OPEARTION CONTROL.....	05-13
19. DEFROST OPERATION CONTROL.....	05-14
20. OFF DEFROST OPERATION CONTROL.....	05-16
21. VARIOUS PROTECTIONS.....	05-17

## **6. REFRIGERANT CAUTION -R410A-**

- 1. R410A TOOLS..... 06-01
- 2. PRECAUTION FOR INSTALLATION..... 06-02
- 3. PRECAUTION FOR SERVICING..... 06-04
- 4. NEW REFRIGERANT R410A..... 06-05
- 5. DEFFERENCE FROM CONVENTIONAL MODEL(R22) AND PRECAUTIONS..... 06-08

## **7. TROUBLE SHOOTING**

- 1. WHEN THE UNIT DOES NOT OPERATE AT ALL..... 07-01
- 2. SELF DIAGNOSIS FUNCTION..... 07-02
- 3. TROUBLE SHOOTING METHOD
- 4. SELF-DIAGNOSIS FUNCTION AND CHECKING POINTS..... 07-03
- 5. SERIAL SIGNAL DIAGNOSIS..... 07-07
- 6. IPM PROTECTION..... 07-08
- 7. TROUBLE SHOOTING OF REFRIGERANT CYCLE..... 07-09

## **8. APPENDING DATA**

- 1. JUMPER SETTING OF INDOOR UNIT AND OUTDOOR UNIT..... 08-01
- 2. OUTDOOR UNIT PRESSURE VALUE AND TOTAL ELECTRIC  
CURRENT CURVE..... 08-02
- 3. THERMISTOR RESISTANCE VALUES..... 08-08
- 4. CAPACITY/INPUT DATA..... 08-09

## **9. REPLACEMENT PARTS**

- 1. EXPLODED VIEW..... 09-01
- 2. INVERTER ASSEMBLY SPECIFICATION..... 09-16

## **10. INSTALLATION MANUAL**

# ***WALL MOUNTED type INVERTER***

## **1 . SPECIFICATIONS**

# SPECIFICATIONS

TYPE	(COOL&HEAT INVERTER)	(COOL&HEAT INVERTER)
INDOOR UNIT	ASYA07LCC	ASYA09LCC
OUTDOOR UNIT	AOYR07LCC	AOYR09LCC
COOLING CAPACITY( ) : Range (kW)	2.1 (0.5~3.0)	2.6 (0.5~3.6)
HEATING CAPACITY( ) : Range (kW)	3.0 (0.5~4.6)	3.6 (0.5~5.3)

## ELECTRICAL DATA

POWER SOURCE (V)	230		
FREQUENCY (Hz)	50		
RUNNING CURRENT (A)	COOLING	2.5	3.2
	HEATING	3.2	4.0
INPUT WATTS (kW)	COOLING	0.47 (0.25~1.08)	0.655 (0.25~1.18)
	HEATING	0.845 (0.25~1.76)	0.845 (0.25~1.96)
EER (kW/kW)	COOLING	4.47	3.97
	HEATING	4.55	4.26
MOISTURE REMOVAL (ℓ/hr)	1.0		1.3
AIR CIRCULATION-Hi (m <sup>3</sup> /hr)	C 595 H645		C 595 H645

## COMPRESSOR

TYPE	Hermetic type,4 pole, 3 phase , DC inverter motor, Rotary	
DISCRIMINATION	DA 89 X 1F-20F	DA 89 X 1F-20F
REFRIGERANT R410A (g)	900	900

Note : Always use a vacuum pump to purge the air.

Refrigerant for purging the air is not charged in the outdoor unit at the factory.

## FAN MOTOR

POWER SOURCE (V)	230		
INDOOR UNIT (r.p.m.)	HI-SPEED	C 1,300 H 1,390	C 1,300 H 1,390
	MED-SPEED	C 1,120 H 1,200	C 1,120 H 1,200
	LO-SPEED	C 950 H 1,000	C 950 H 1,000
	QUIET	C 700 H 760	C 700 H 760
OUTDOOR UNIT (r.p.m.)	800		

## DIMENSIONS

INDOOR UNIT H x W x D (mm)	275 x 790 x 215	
OUTDOOR UNIT H x W x D (mm)	540 x 660 x 290	

## WEIGHTS

INDOOR UNIT GROSS / NET (kg)	12 / 9	
OUTDOOR UNIT GROSS / NET (kg)	35 / 34	35 / 34

## NOISE LEVEL

INDOOR UNIT (dB)	HI-SPEED	C 41 H 41	C 41 H 41
	MED-SPEED	C 36 H 36	C 36 H 36
	LO-SPEED	C 30 H 30	C 30 H 30
	QUIET	C 21 H 21	C 21 H 21
OUTDOOR UNIT (dB)	C 47 H 48		

Note : Noise was measured in accordance with JIS standards, Japan.

MAX PIPE LENGTH	20 m	
ADDITIONAL REFRIGERANT	15m chargeless, 20g/m (>15m)	

## THICKNESSES OF ANNEALED COPPER PIPES

		Thickness (mm)	
Nominal diameter	Outer diameter (mm)	R410A	[ref,] R22
1/4	6.35	0.80	0.80
3/8	9.52	0.80	0.80

# SPECIFICATIONS

TYPE		COOL & HEAT INVERTER		
INDOOR UNIT		ASYA12LCC	ASYA14LCC	ASYA18LCC
OUTDOOR UNIT		AOYR12LCC	AOYR14LCC	AOYR18LCC
COOLING CAPACITY	(kW)	3.50(0.9~4.3)	4.20(0.9~5.3)	5.20(0.9~5.7)
HEATING CAPACITY	(kW)	4.80(0.9~6.7)	5.60(0.9~8.4)	6.25(0.9~9.1)

## ELECTRICAL DATA

POWER SOURCE	(V)	230		
FREQUENCY	(Hz)	50		
RUNNING CURRENT (A)	COOLING	4.3	5.0	7.6
	HEATING	5.6	6.4	7.7
INPUT WATTS (kW)	COOLING	0.92(0.25~1.61)	1.11(0.09~1.75)	1.72(0.09~2.00)
	HEATING	1.24(0.25~2.30)	1.45(0.09~2.48)	1.73(0.09~2.66)
E.E.R. (kW/kW)	COOLING	3.80	3.78	3.02
COP (kW/kW)	HEATING	3.87	3.86	3.61
MOISTURE REMOVAL	(ℓ/hr)	1.8	2.1	2.8
AIR CIRCULATION-Hi	(m <sup>3</sup> /hr)	C 635 H 670	C 700 H 700	C 700 H 700

## COMPRESSOR

TYPE	Hermetic type, 4 pole, 3 phase, DC inverter motor, Rotary		
DISCRIMINATION	DA 89 X 1F - 20F		
REFRIGERANT R410A (g)	1,050	1,150	1,150

## FAN MOTOR

POWER SOURCE	(V)	230		
INDOOR UNIT	HI-SPEED (r.p.m.)	C 1,370 H 1,440	C 1,480 H 1,480	C 1,480 H 1,480
	MED-SPEED (r.p.m.)	C 1,150 H 1,200	C 1,260 H 1,300	C 1,260 H 1,300
	LO-SPEED (r.p.m.)	C 950 H 1,000	C 1,040 H 1,110	C 1,040 H 1,110
	QUIET (r.p.m.)	C 700 H 760	C 850 H 950	C 850 H 950
OUTDOOR UNIT	(r.p.m.)	C 830 H 830	C 860 H 820	C 860 H 820

## DIMENSIONS

INDOOR UNIT	H x W x D (mm)	275 x 790 x 215	
OUTDOOR UNIT	H x W x D (mm)	540 x 790 x 290	578 x 790 x 300

## WEIGHT

INDOOR UNIT	GROSS / NET (kg)	12 / 9	
OUTDOOR UNIT	GROSS / NET (kg)	41 / 37	44 / 40

## NOISE LEVEL

INDOOR UNIT	HI-SPEED	C 42 H 42	C 44 H 42	C 44 H 44
	MED-SPEED	C 36 H 35	C 38 H 37	C 38 H 37
	LO-SPEED	C 30 H 29	C 32 H 32	C 32 H 32
	(dB) QUIET	C 21 H 21	C 25 H 27	C 25 H 27
OUTDOOR UNIT	(dB)	C 47 H 49	C 48 H 49	C 50 H 50

Note : Noise was measured in accordance with JIS standards, Japan.

MAX PIPE LENGTH	20 m
ADDITIONAL REFRIGERANT	15m chargeless, 20g/m (>15m)

## THICKNESSES OF ANNEALED COPPER PIPES

		Thickness (mm)	
Nominal diameter	Outer diameter (mm)	R410A	[ref.] R22
1/4	6.35	0.80	0.80
3/8	9.52	0.80	0.80
5/8	12.7	0.80	0.80

# SPECIFICATIONS

TYPE	(COOL&HEAT INVERTER)	(COOL&HEAT INVERTER)
INDOOR UNIT	ASYB09LDC	ASYB12LDC
OUTDOOR UNIT	AOYS09LDC	AOYS12LDC
COOLING CAPACITY( ) : Range (kW)	2.6 (0.5~3.7)	3.5 (0.9~4.3)
HEATING CAPACITY( ) : Range (kW)	3.6 (0.5~6.1)	4.8 (0.9~6.7)

## ELECTRICAL DATA

POWER SOURCE (V)	230		
FREQUENCY (Hz)	50		
RUNNING CURRENT (A)	COOLING	2.9	4.3
	HEATING	3.9	5.5
INPUT WATTS (kW)	COOLING	0.61 (0.25~1.38)	0.91 (0.25~1.61)
	HEATING	0.81 (0.25~1.96)	1.22 (0.25~2.30)
EER (kW/kW)	COOLING	4.26	3.85
	HEATING	4.44	3.93
MOISTURE REMOVAL (ℓ/hr)	1.3	1.8	
AIR CIRCULATION-Hi (m³/hr)	C 595 H645	C 595 H645	

## COMPRESSOR

TYPE	Hermetic type, 4 pole, 3 phase, DC inverter motor, Rotary	
DISCRIMINATION	DA 89 X 1F-20F	DA 89 X 1F-20F
REFRIGERANT R410A (g)	950	1,050

Note : Always use a vacuum pump to purge the air.

Refrigerant for purging the air is not charged in the outdoor unit at the factory.

## FAN MOTOR

POWER SOURCE (V)	230		
INDOOR UNIT (r.p.m.)	HI-SPEED	C 1,300 H 1,390	C 1,370 H 1,440
	MED-SPEED	C 1,120 H 1,200	C 1,150 H 1,200
	LO-SPEED	C 950 H 1,000	C 950 H 1,000
	QUIET	C 700 H 760	C 700 H 760
OUTDOOR UNIT (r.p.m.)	C 800 H 760		

## DIMENSIONS

INDOOR UNIT H x W x D (mm)	283 x 790 x 230
OUTDOOR UNIT H x W x D (mm)	540 x 790 x 290

## WEIGHTS

INDOOR UNIT GROSS / NET (kg)	12 / 9.5	
OUTDOOR UNIT GROSS / NET (kg)	38 / 34	40 / 36

## NOISE LEVEL

INDOOR UNIT (dB)	HI-SPEED	C 39 H 40	C 41 H 41
	MED-SPEED	C 34 H 35	C 35 H 35
	LO-SPEED	C 29 H 28	C 29 H 28
	QUIET	C 20 H 21	C 20 H 21
OUTDOOR UNIT (dB)	C 47 H 48	C 47 H 49	

Note : Noise was measured in accordance with JIS standards, Japan.

MAX PIPE LENGTH	20 m
ADDITIONAL REFRIGERANT	15m chargeless, 20g/m (>15m)

## THICKNESSES OF ANNEALED COPPER PIPES

		Thickness (mm)	
Nominal diameter	Outer diameter (mm)	R410A	[ref.] R22
1/4	6.35	0.80	0.80
3/8	9.52	0.80	0.80

# ***WALL MOUNTED type INVERTER***

## **2 . DIMENSIONS**



# DIMENSIONS

Models : ASYA07LCC / AOYR07LCC  
ASYA09LCC / AOYR09LCC

(unit : mm)

## INDOOR UNIT

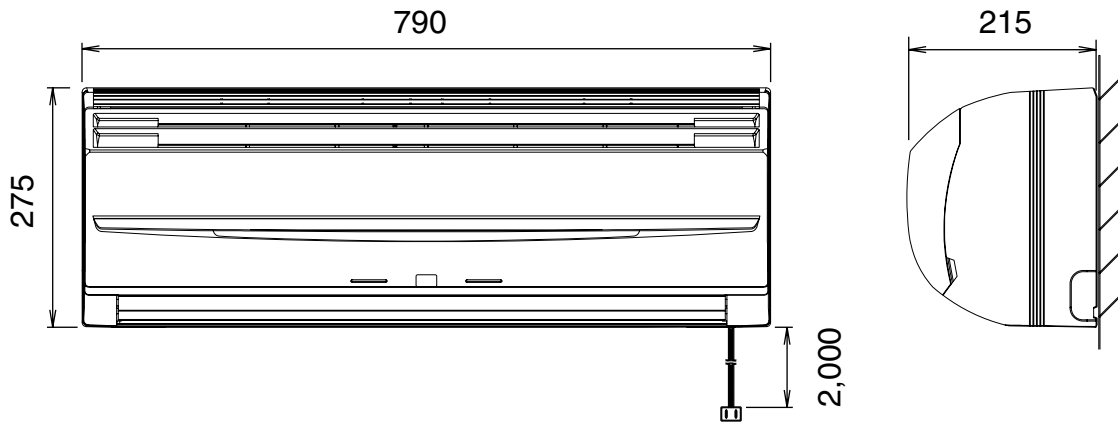

## OUTDOOR UNIT

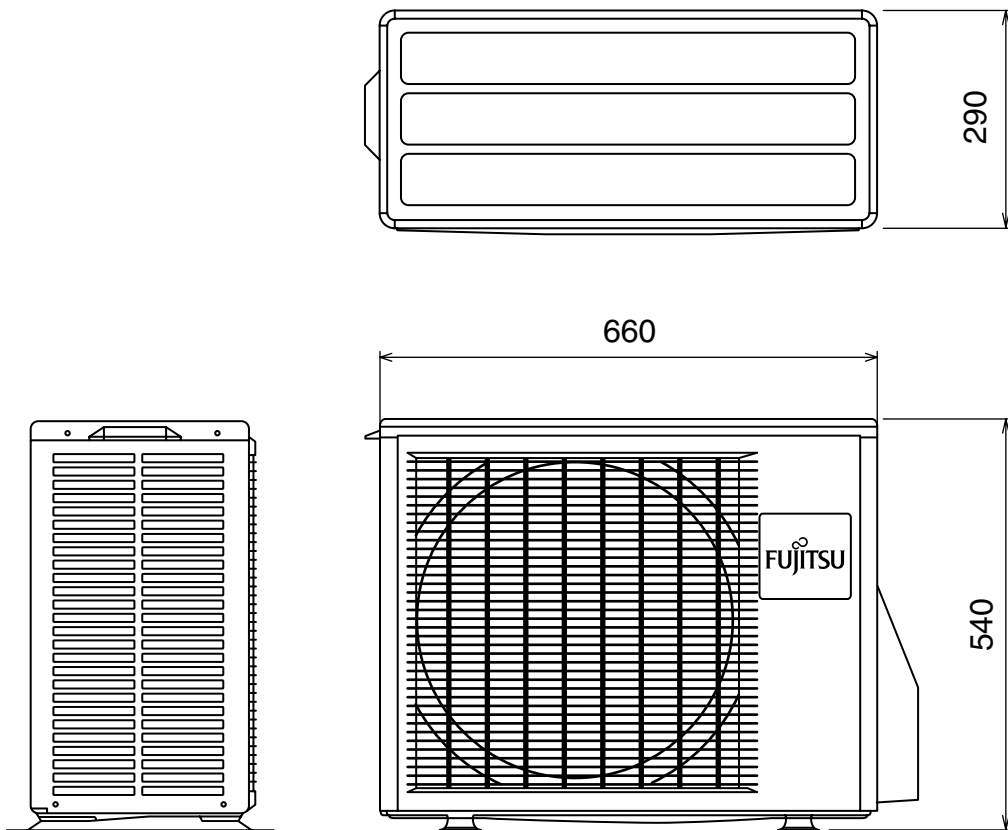

# DIMENSIONS

Models : ASYA12LCC / AOYR12LCC

(unit : mm)

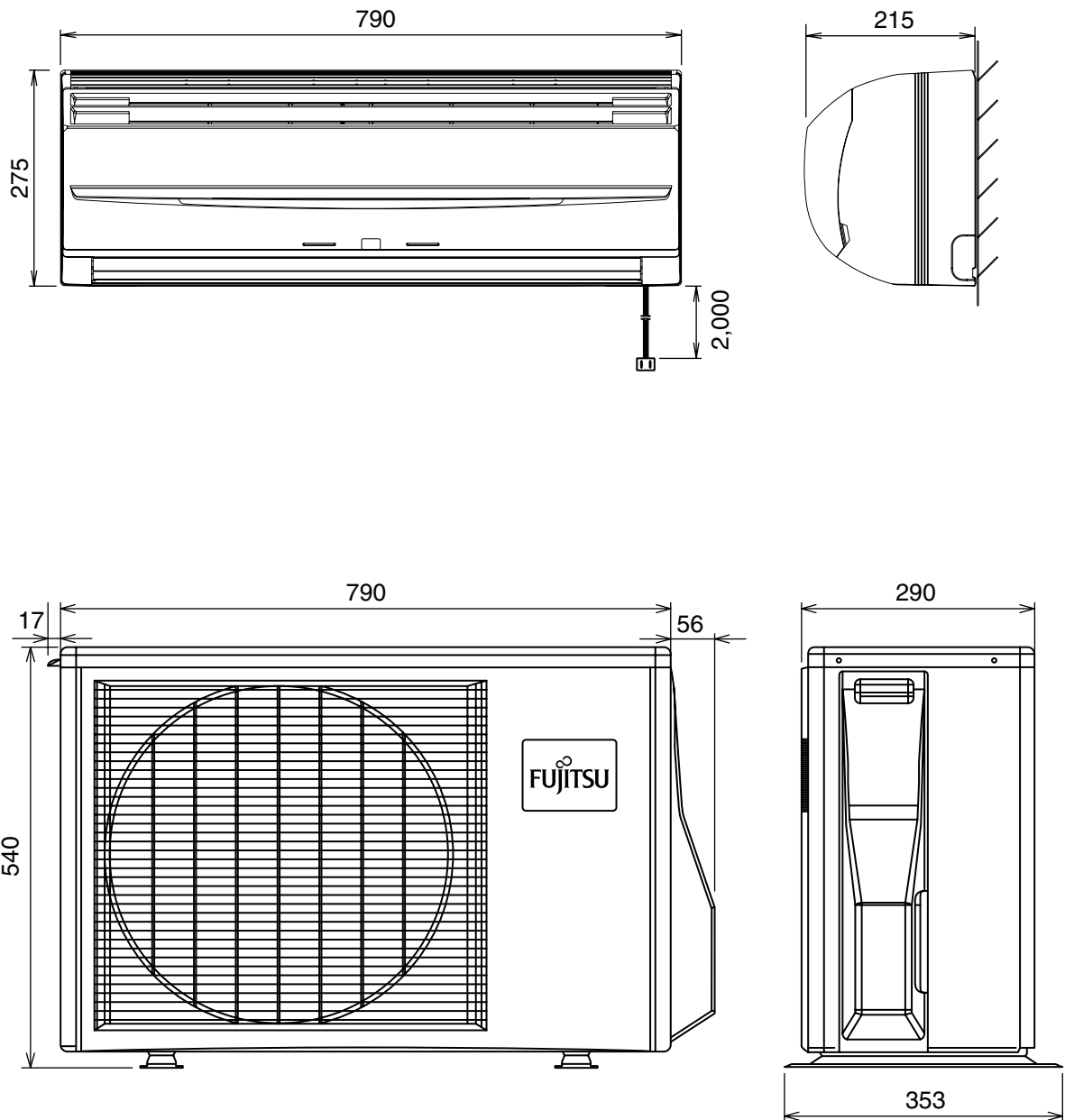

# DIMENSIONS

Models : ASYB09LDC / AOYS09LDC  
ASYB12LDC / AOYS12LDC

(unit : mm)

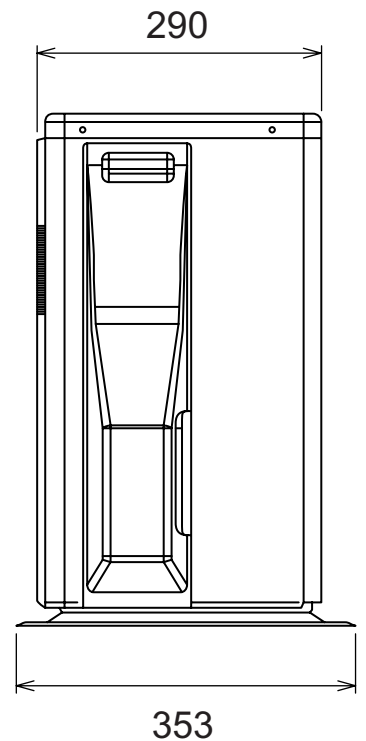
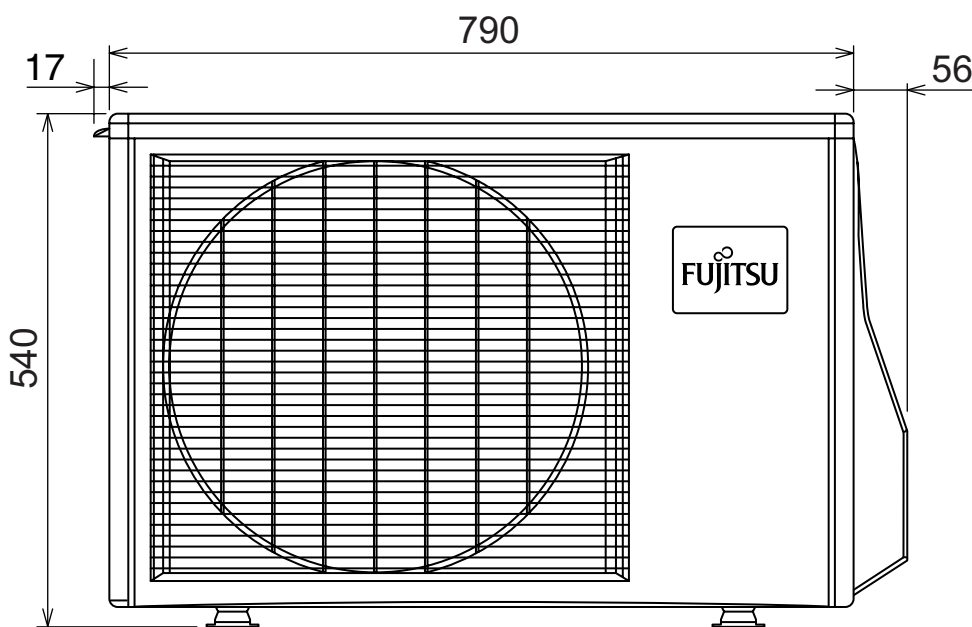
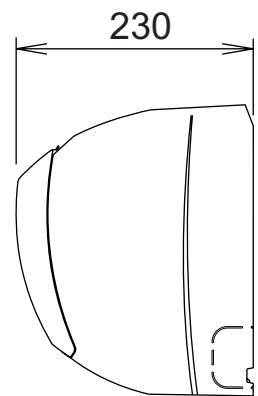
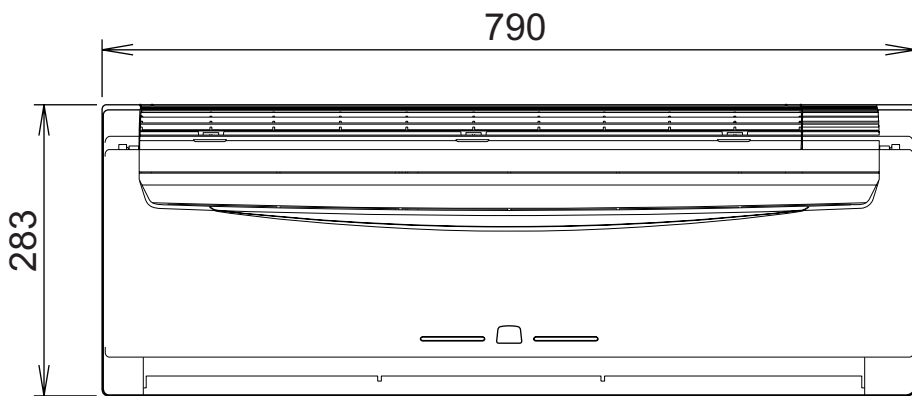

# DIMENSIONS

Models : ASYA14LCC / AOYR14LCC  
ASYA18LCC / AOYR18LCC

(unit : mm)

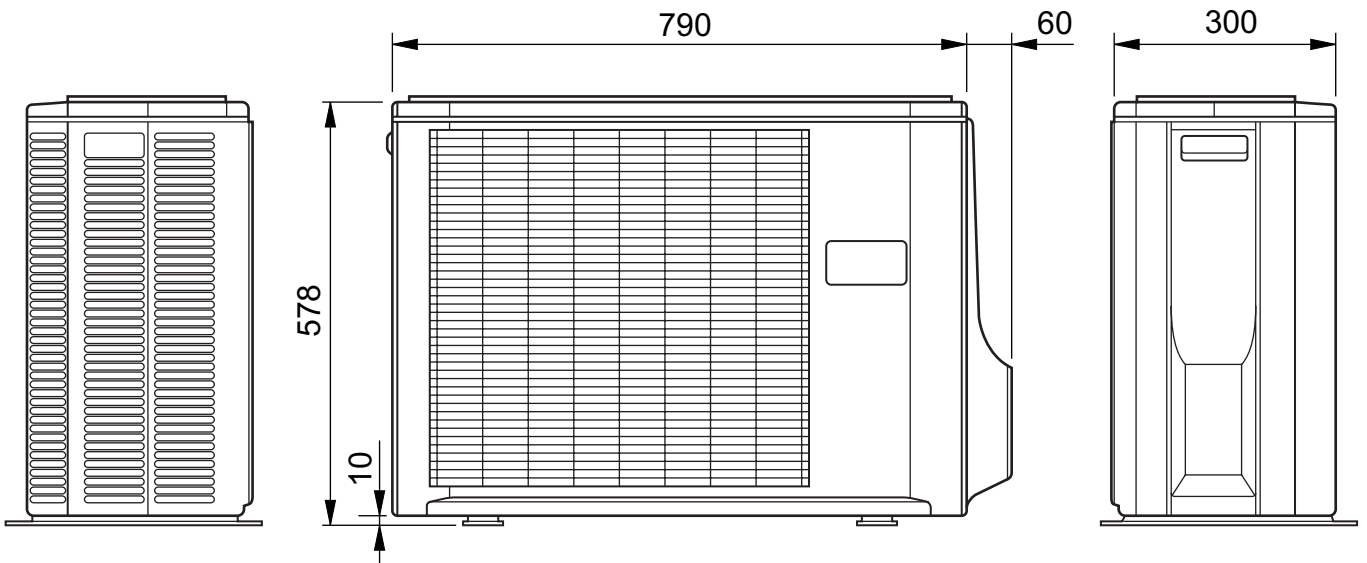
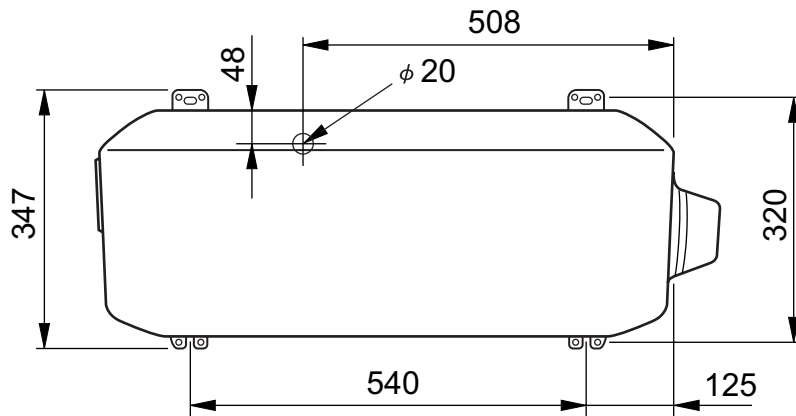
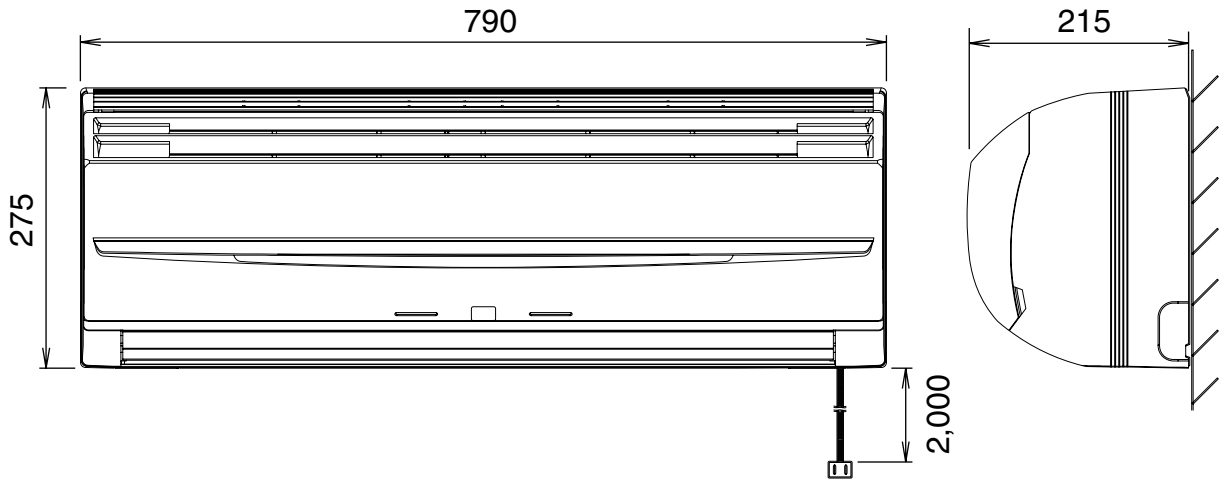

# ***WALL MOUNTED type INVERTER***

## **3 . REFRIGERANT SYSTEM DIAGRAM**

# REFRIGERANT SYSTEM DIAGRAM

Models : ASYA07LCC / AOYR07LCC  
 ASYA09LCC / AOYR09LCC

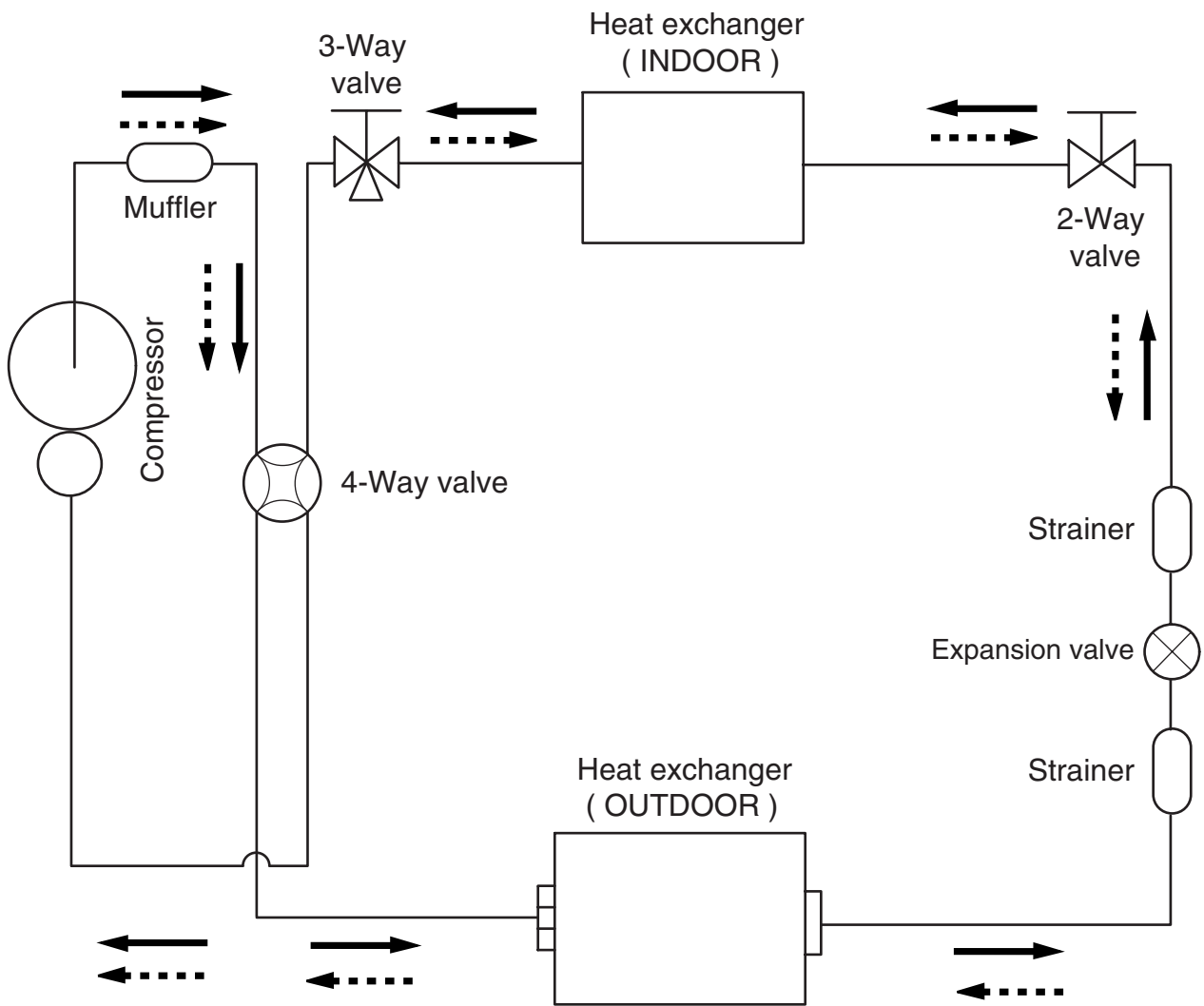

 Cooling  
 Heating

Refrigerant pipe diameter  
 Liquid : 1/4" (6.35 mm)  
 Gas : 3/8" (9.52 mm)

# REFRIGERANT SYSTEM DIAGRAM

Models : ASYA12LCC / AOYR12LCC  
 ASYB09LDC / AOYS09LDC  
 ASYB12LDC / AOYS12LDC

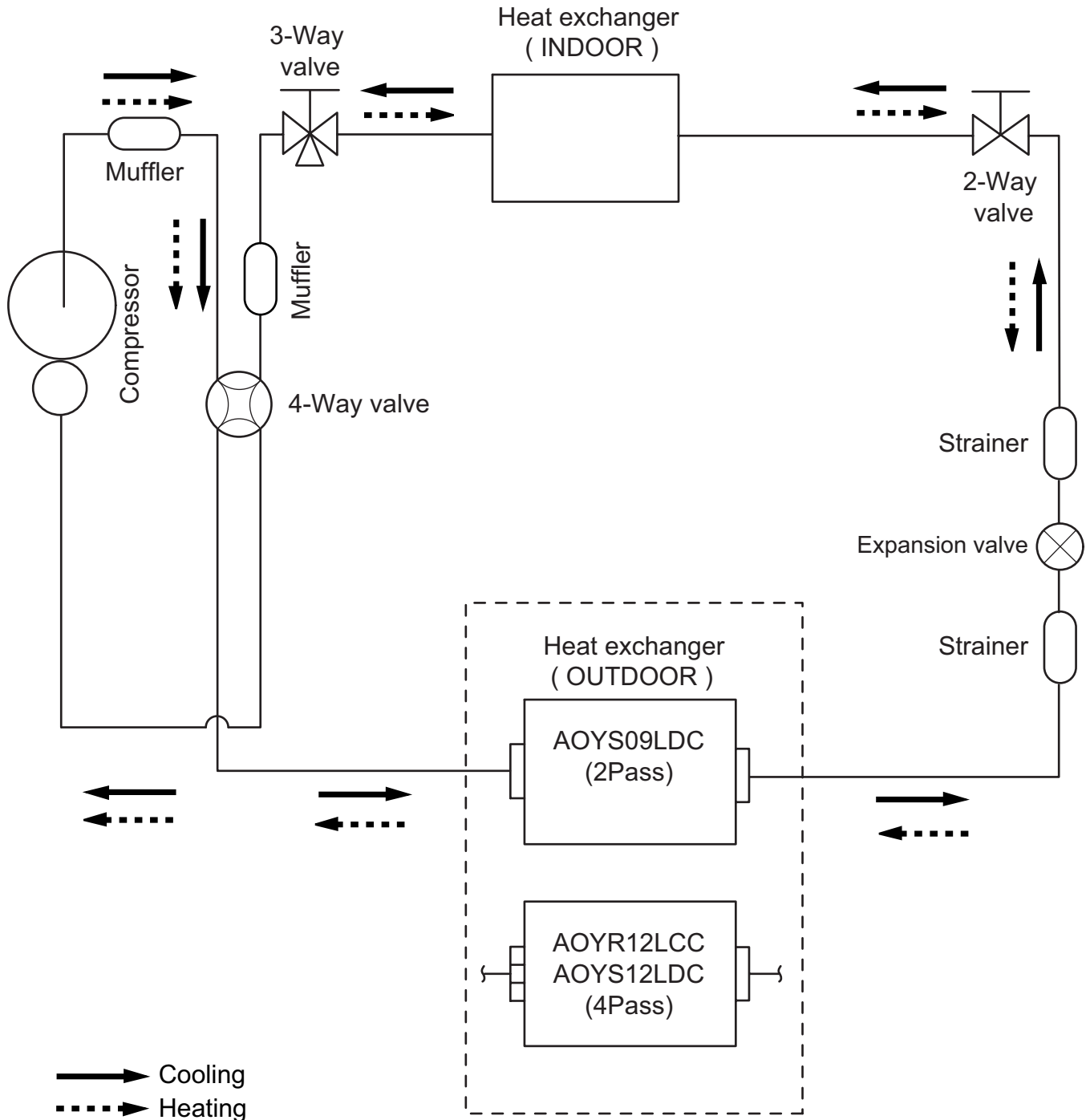

# REFRIGERANT SYSTEM DIAGRAM

Models : ASYA14LCC / AOYR14LCC  
ASYA18LCC / AOYR18LCC

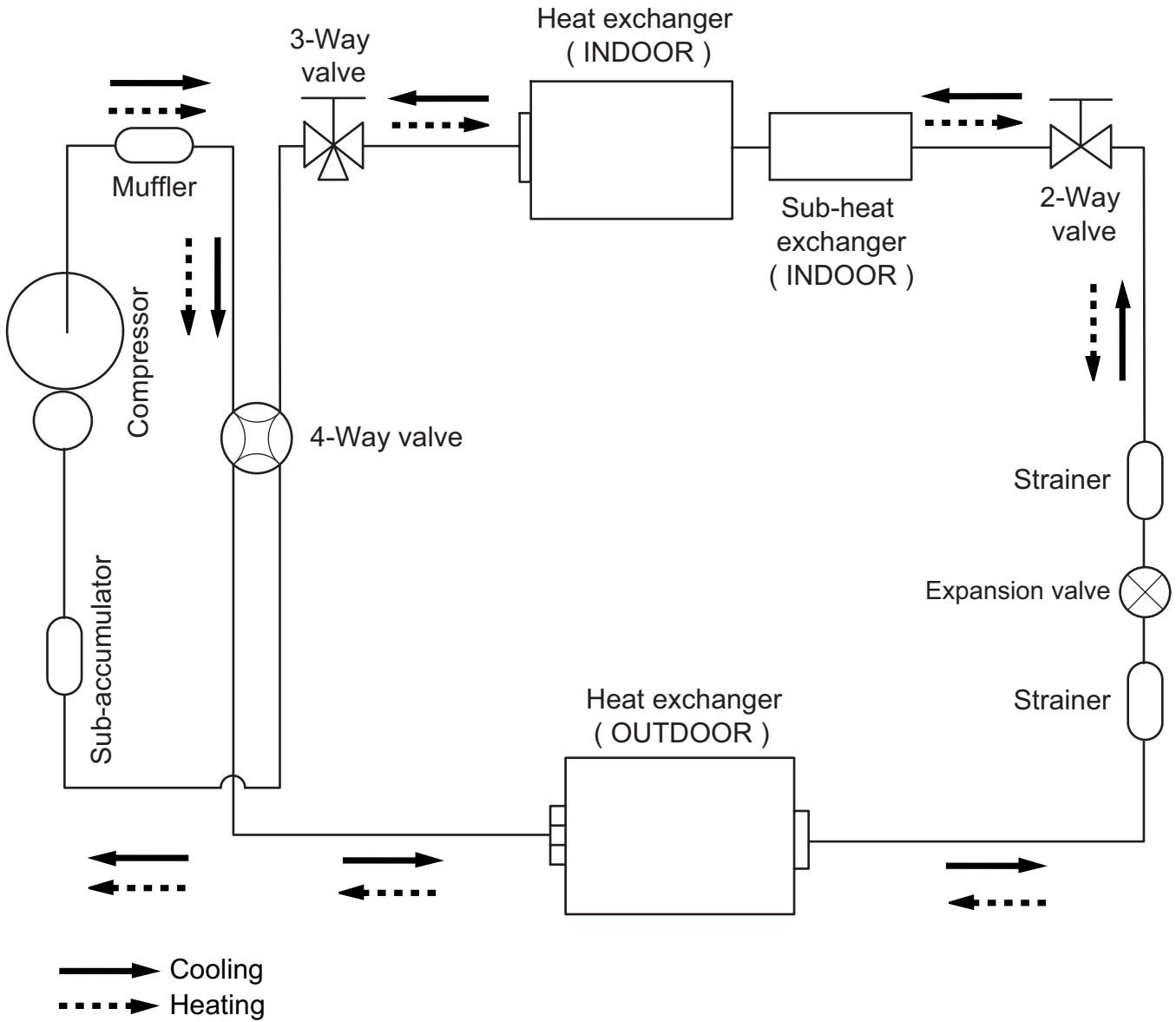



# ***WALL MOUNTED type INVERTER***

## **4 . CIRCUIT DIAGRAM**

# CIRCUIT DIAGRAM

Models : ASYA07LCC / AOYR07LCC  
 ASYA09LCC / AOYR09LCC

## INDOOR UNIT

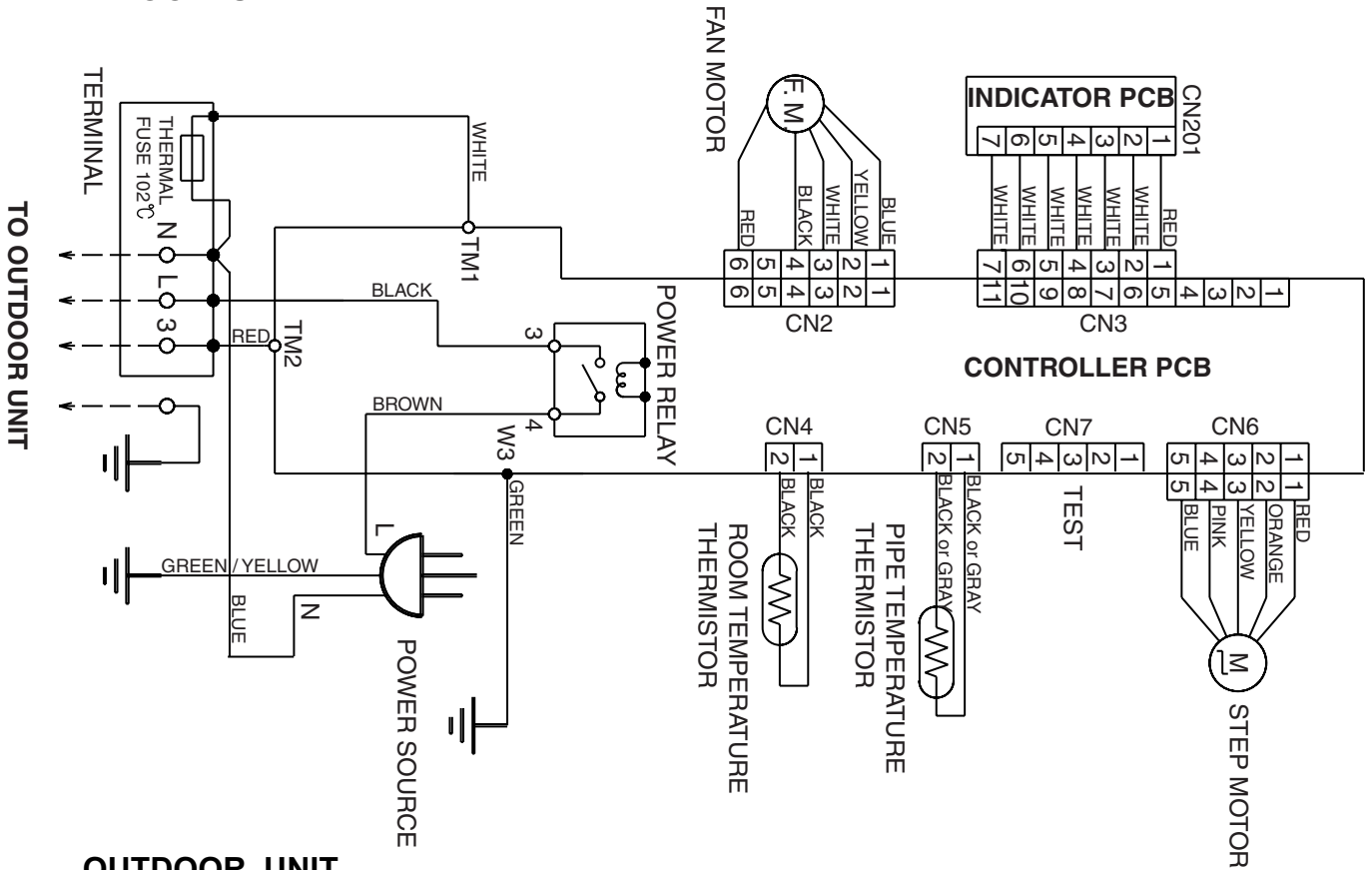

## OUTDOOR UNIT

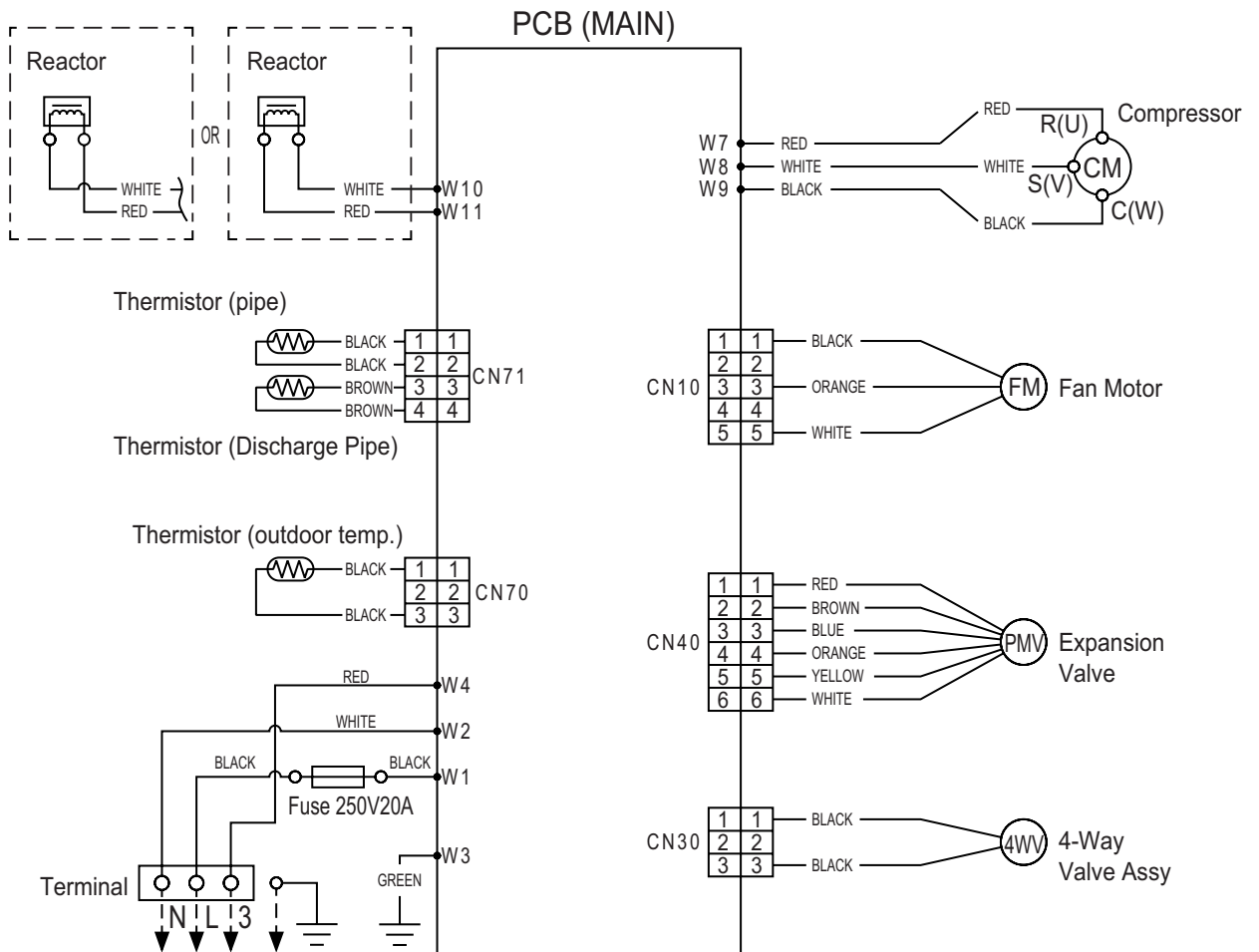

# CIRCUIT DIAGRAM

Models : ASYA12LCC / AOYR12LCC

## INDOOR UNIT

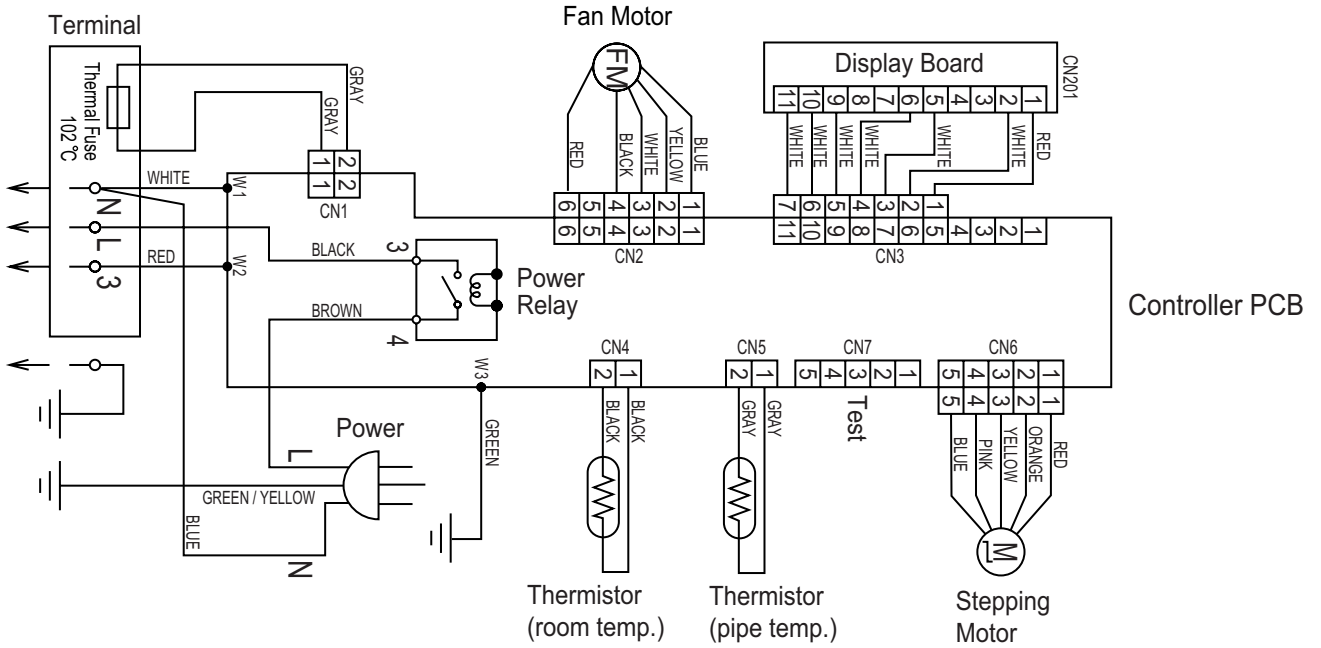

## OUTDOOR UNIT

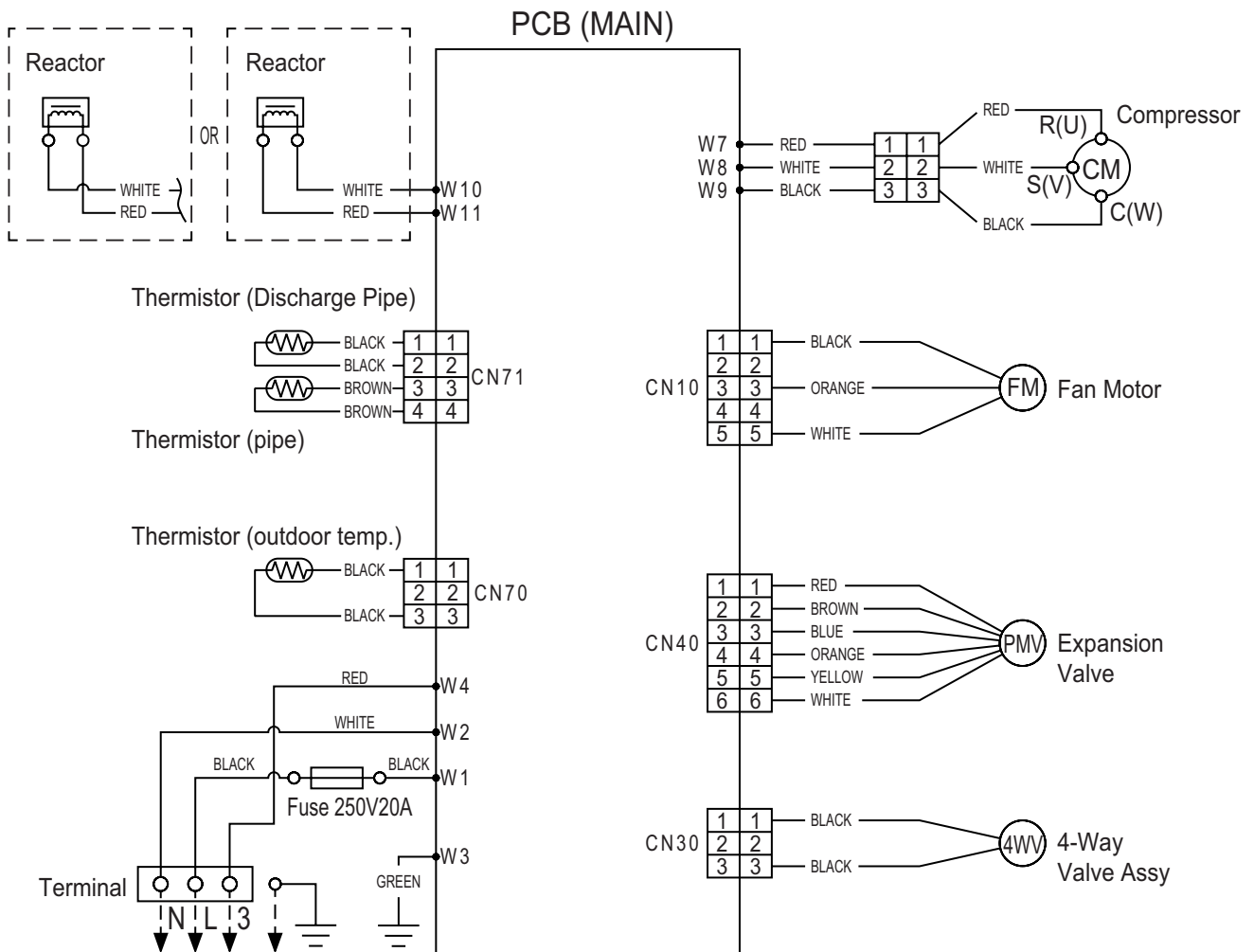

# CIRCUIT DIAGRAM

Models : ASYB09LDC / AOYS09LDC  
ASYB12LDC / AOYS12LDC

## INDOOR UNIT

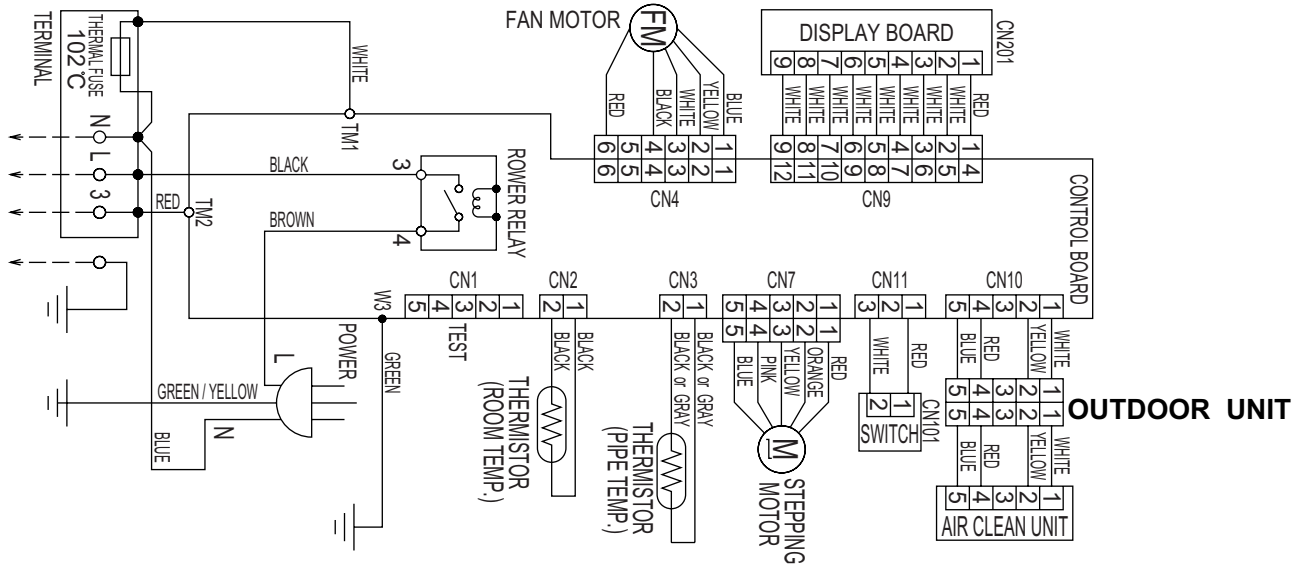

## OUTDOOR UNIT

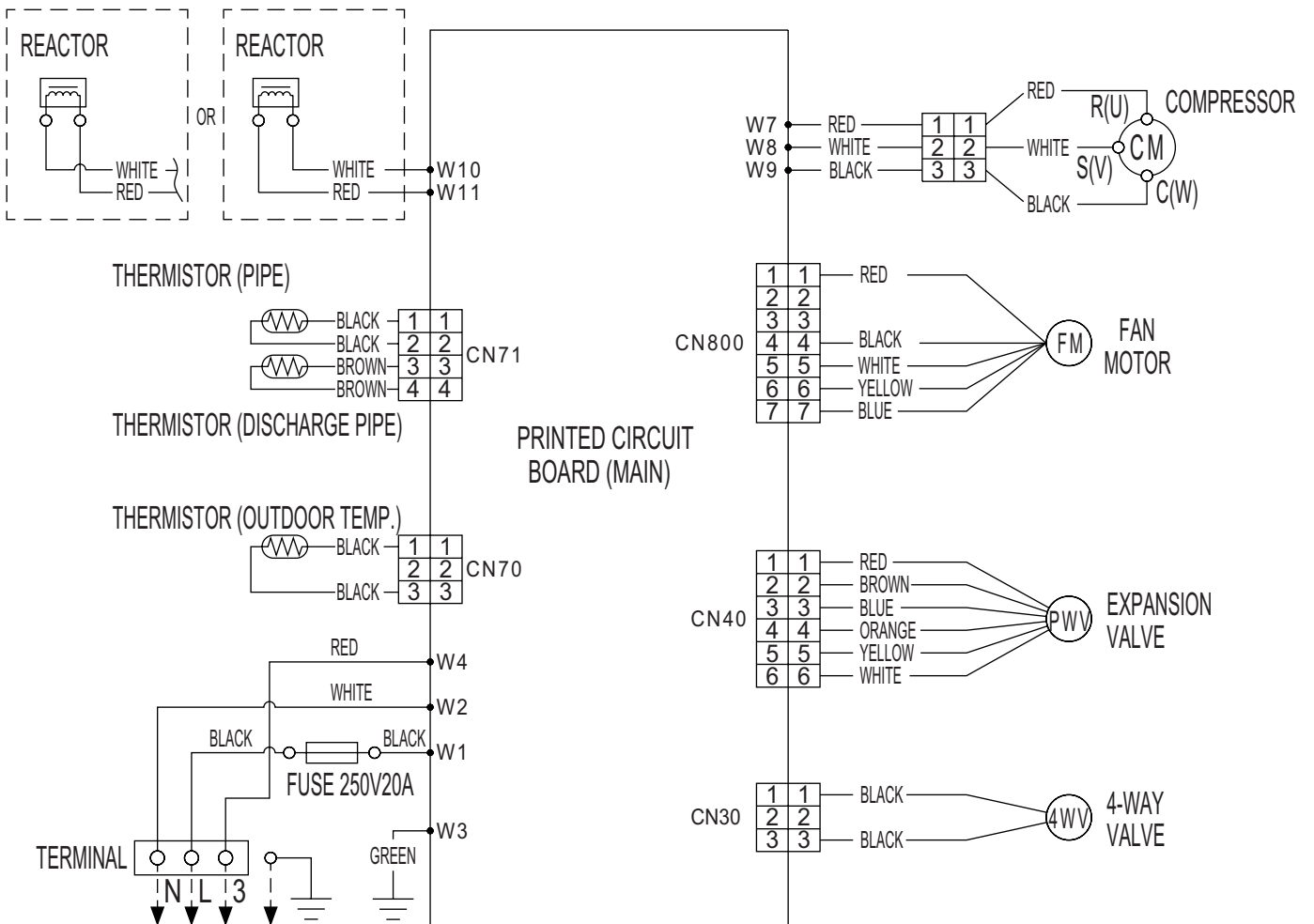

# CIRCUIT DIAGRAM

Models : ASYA14LCC / AOYR14LCC  
 ASYA18LCC / AOYR18LCC

INDOOR UNIT

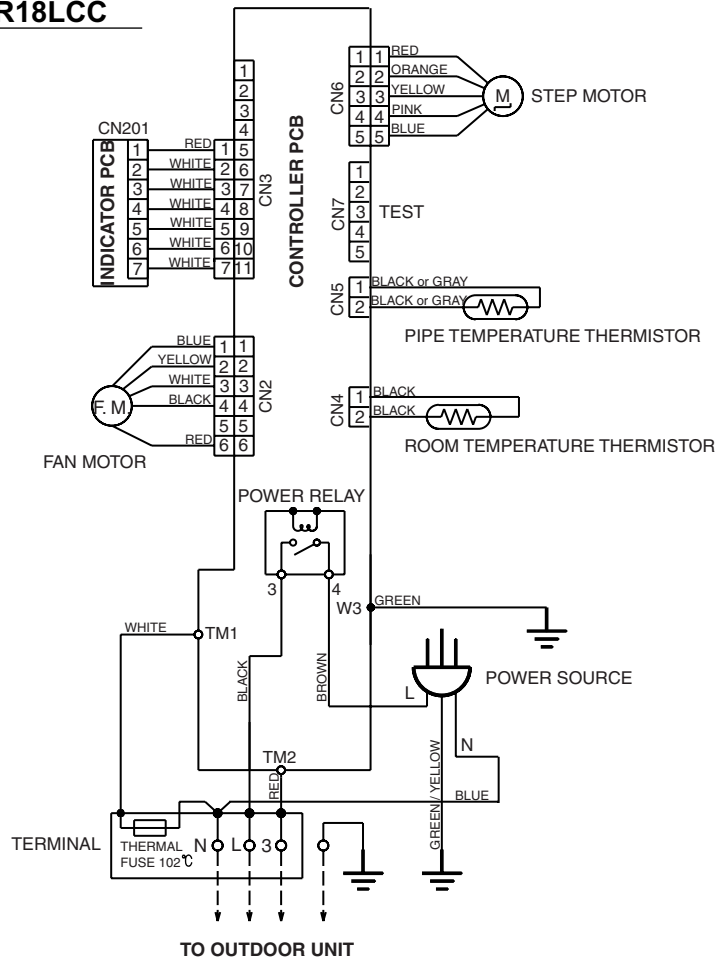

OUTDOOR UNIT

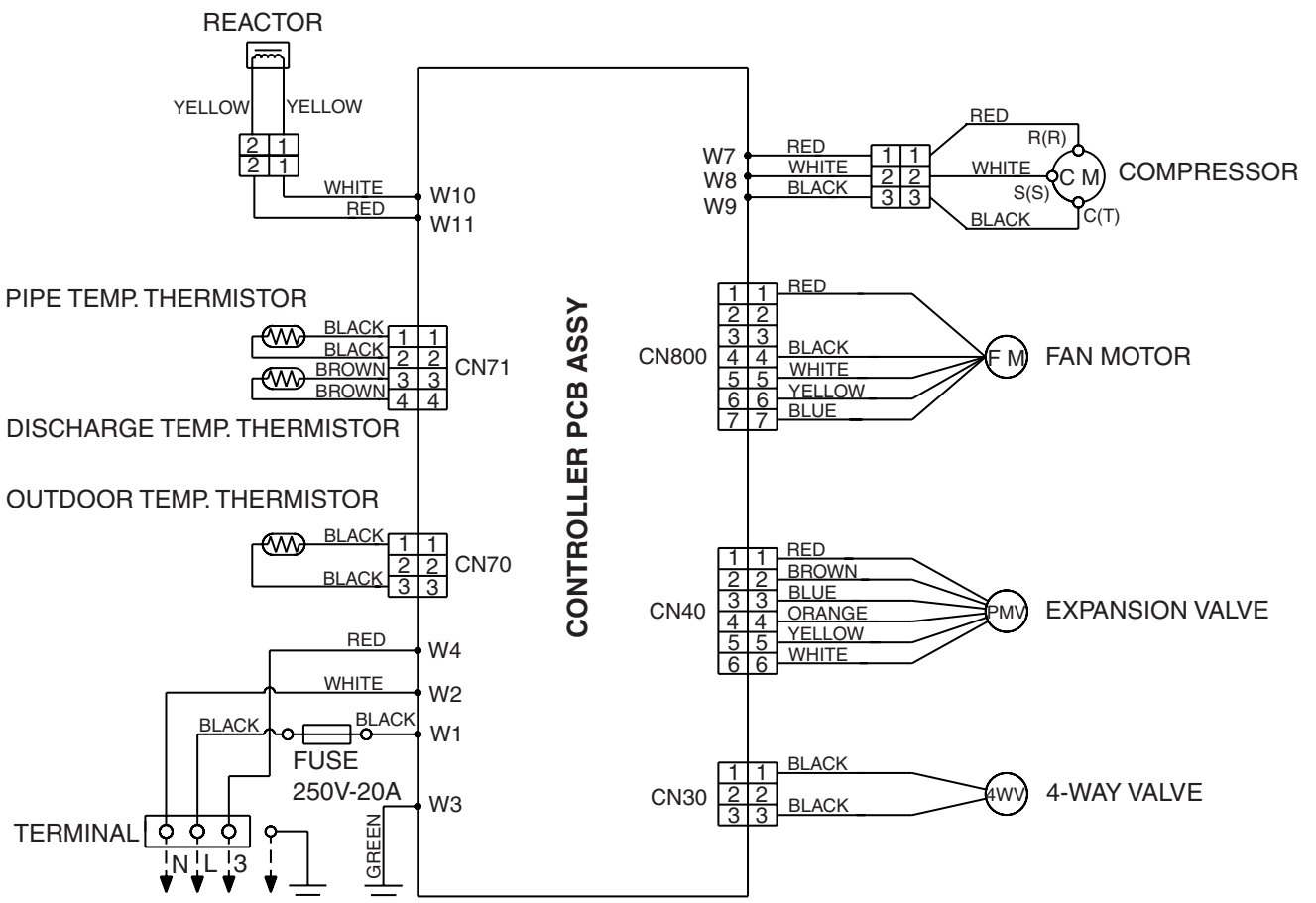

# *WALL MOUNTED type INVERTER*

## **5 . DESCRIPTION OF EACH CONTROL OPERATION**

# 1. COOLING OPERATION

## 1-1 COOLING CAPACITY CONTROL

A sensor (room temperature thermistor) built in the indoor unit body will usually perceive difference or variation between a set temperature and present room temperature, and controls the operation frequency of the compressor.

\* If the room temperature is 2°C higher than a set temperature, the compressor operation frequency will attain to maximum performance.

\* If the room temperature is 2.5°C lower than a set temperature, the compressor will be stopped.

\* When the room temperature is between +2°C to -2.5°C of the setting temperature, the compressor frequency is controlled within the range shown in Table 1.

However, the maximum frequency is limited in the range shown in Figure 1 based on the fan speed mode and the outdoor temperature.

( Table 1 : Compressor Frequency Range )

	minimum frequency	maximum frequency II	maximum frequency I
ASYA07LCC	18Hz	61Hz	80Hz
ASYA09LCC	18Hz	61Hz	80Hz
ASYA12LCC	18Hz	80Hz	96Hz
ASYB09LDC	18Hz	61Hz	80Hz
ASYB12LDC	18Hz	80Hz	96Hz
ASYA14LCC	18Hz	70Hz	90Hz
ASYA18LCC	18Hz	70Hz	90Hz

( Fig. 1 : Limit of Maximum Frequency based on Outdoor Temperature )

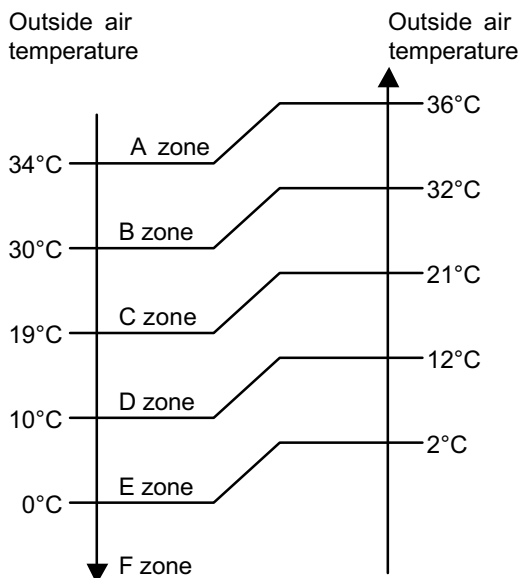

		Hi	Me	Lo	Quiet
07LCC 09LCC	A zone	80Hz	61Hz	51Hz	33Hz
	B zone	80Hz	61Hz	51Hz	33Hz
	C zone	80Hz	61Hz	51Hz	33Hz
	D zone	51Hz	42Hz	36Hz	21Hz
	E zone	51Hz	42Hz	36Hz	21Hz
	F zone	51Hz	42Hz	36Hz	21Hz
12LCC	A zone	96Hz	61Hz	51Hz	33Hz
	B zone	96Hz	61Hz	51Hz	33Hz
	C zone	96Hz	61Hz	51Hz	33Hz
	D zone	51Hz	42Hz	36Hz	22Hz
	E zone	51Hz	42Hz	36Hz	22Hz
	F zone	51Hz	42Hz	36Hz	22Hz
09LDC	A zone	80Hz	61Hz	51Hz	33Hz
	B zone	80Hz	61Hz	51Hz	33Hz
	C zone	80Hz	61Hz	51Hz	33Hz
	D zone	51Hz	42Hz	36Hz	27Hz
	E zone	51Hz	42Hz	36Hz	27Hz
	F zone	51Hz	42Hz	36Hz	27Hz
12LDC	A zone	96Hz	61Hz	51Hz	33Hz
	B zone	96Hz	61Hz	51Hz	33Hz
	C zone	96Hz	61Hz	51Hz	33Hz
	D zone	57Hz	42Hz	36Hz	27Hz
	E zone	57Hz	42Hz	36Hz	27Hz
	F zone	57Hz	42Hz	36Hz	27Hz
14LCC 18LCC	A zone	90Hz	45Hz	42Hz	30Hz
	B zone	90Hz	45Hz	42Hz	30Hz
	C zone	90Hz	45Hz	42Hz	30Hz
	D zone	58Hz	38Hz	34Hz	24Hz
	E zone	58Hz	38Hz	34Hz	24Hz
	F zone	58Hz	38Hz	34Hz	24Hz

When the compressor operates for 30 minutes continuously at over the maximum frequency II, the maximum frequency is changed from Maximum Frequency I to Maximum Frequency II. The room temperature is controlled 1°C lower than the setting temperature for 40 minutes after starting the operation.

After 40 minutes, it is controlled based on the normal setting temperature.

## 2. HEATING OPERATION

### 2-1 HEATING CAPACITY CONTROL

A sensor (room temperature thermistor) built in the indoor unit body will usually perceive difference or variation between a set temperature and present room temperature, and controls the operation frequency of the compressor.

- \* If the room temperature is lower by 3°C than a set temperature, the compressor operation frequency will attain to maximum performance.
- \* If the room temperature is higher 2.5°C than a set temperature, the compressor will be stopped.
- \* When the room temperature is between +2°C to -3°C of the setting temperature, the compressor frequency is controlled within the range shown in Table2. However, the maximum frequency is limited in the range shown in Figure 2 based on the fan speed mode and the outdoor temperature.

( Table 2 : Compressor Frequency Range )

	minimum frequency	maximum frequency
ASYA07LCC	18Hz	130Hz
ASYA09LCC	18Hz	130Hz
ASYA12LCC	18Hz	130Hz
ASYB09LDC	18Hz	130Hz
ASYB12LDC	18Hz	130Hz
ASYA14LCC	18Hz	119Hz
ASYA18LCC	18Hz	119Hz

( Fig.2 : Limit of Maximum Frequency based on Outdoor Temperature )

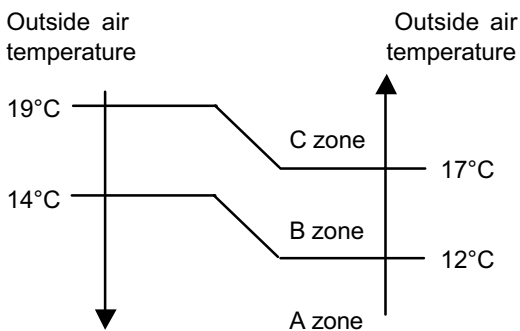

		Hi	Me	Lo	Quiet
07/09/12LCC 09/12LDC	A zone	130Hz	96Hz	80Hz	68Hz
	B zone	130Hz	96Hz	80Hz	54Hz
	C zone	130Hz	96Hz	80Hz	45Hz
14/18LCC	A zone	119Hz	90Hz	70Hz	58Hz
	B zone	119Hz	90Hz	70Hz	58Hz
	C zone	119Hz	90Hz	70Hz	58Hz

- \* The room temperature is controlled 2°C higher than the setting temperature for 60 minutes after starting the operation. After 60 minutes, it is controlled based on the normal setting temperature.



## 3. DRY OPERATION

### 3-1 INDOOR UNIT CONTROL

The compressor rotation frequency shall change according to the temperature, set temperature, and room temperature variation which the room temperature sensor of the indoor unit body has detected as shown in the Table 3. However, after the compressor is driven, the indoor unit shall run at operation frequency of 58Hz, for a minute.

( Table 3 : Compressor frequency )

	Operating frequency
ASYA07LCC	33Hz
ASYA09LCC	33Hz
ASYA12LCC	33Hz
ASYB09LDC	33Hz
ASYB12LDC	33Hz
ASYA14LCC	24Hz
ASYA18LCC	24Hz

( Fig.3 : Compressor Control based on Room Temperature )

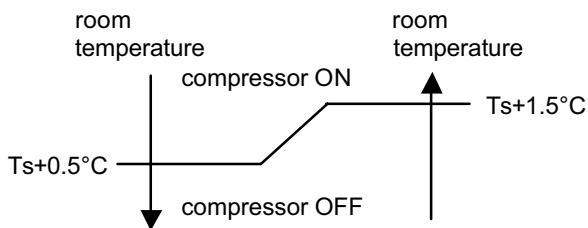

( Fig.4 : Indoor Fan Control )

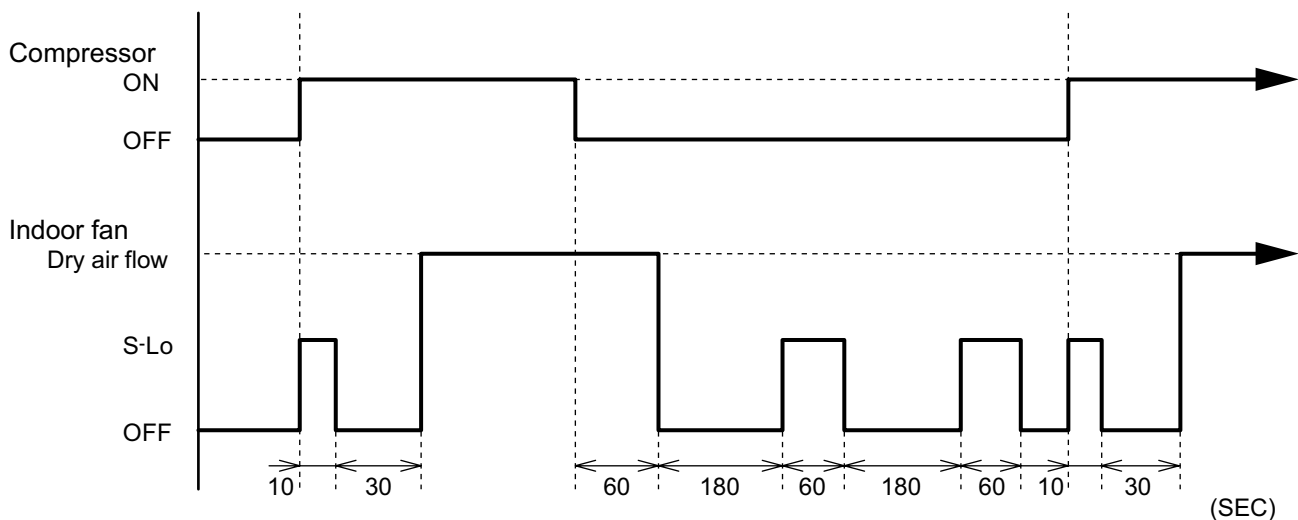

## 4. AUTO CHANGEOVER OPERATION

When the air conditioner is set to the AUTO mode by remote control, operation starts in the optimum mode from among the HEATING, COOLING, DRY and MONITORING modes. During operation, the optimum mode is automatically switched in accordance with temperature changes. The temperature can be set between 18°C and 30°C in 1°C steps.

- ①. When operation starts, only the indoor and outdoor fans are operated for 1 minute. After 1 minute, the room temperature and outside air temperature are sensed and the operation mode is selected in accordance with the table below.

( Fig.5 : Outside air temperature zone selection )

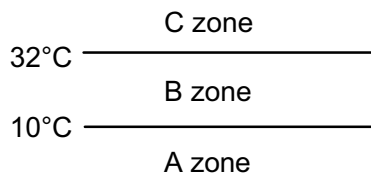

( Table.4 Operation mode selection table )

Room temperature(TB) \ Outside air temperature (TO)	A zone	B zone	C zone
$TB > TS + 2^{\circ}\text{C}$	Monitoring	Cooling (automatic dry)	Cooling (automatic dry)
$TS + 2^{\circ}\text{C} \geq TB \geq TS - 2^{\circ}\text{C}$	Monitoring	Monitoring	Monitoring
$TB < TS - 2^{\circ}\text{C}$	Heating	Heating	Monitoring

- ②. When COOLING was selected at ①, the air conditioner operates as follows:
- The same operation as COOLING OPERATION of item 1 above is performed.
  - When the room temperature has remained at (set temperature-1°C) for 8 minutes, operation is automatically switched to DRY and the same operation as DRY OPERATION of item 3 above is performed.
  - If the room temperature reaches (set temperature+2°C during DRY operation, operation returns to COOLING operation.
- ③. When HEATING was selected at ①, the same operation as HEATING OPERATION of item 2 above is performed.
- ④. When the compressor was stopped for 6 consecutive minutes by the temperature control function after the COOLING or HEATING operation mode was selected at ① above, operation is switched to MONITORING and the operation mode is selected again.

## 5. INDOOR FAN CONTROL

### (1).Fan speed

( Table 5 : Indoor Fan Speed )

07/09LCC, 09LDC			12LCC, 12LDC		
Operation mode	Air flow mode	Speed (rpm)	Operation mode	Air flow mode	Speed (rpm)
Heating	Hi	1390	Heating	Hi	1440
	Me+	1350		Me+	1350
	Me	1200		Me	1200
	Lo	1000		Lo	1000
	Quiet	760		Quiet	760
	Cool air prevention	760		Cool air prevention	760
	S-Lo	480		S-Lo	480
Cooling Fan	Hi	1300	Cooling Fan	Hi	1370
	Me	1120		Me	1150
	Lo	950		Lo	950
	Quiet	700		Quiet	700
Dry		700	Dry		700

14/18LCC		
Operation mode	Air flow mode	Speed (rpm)
Heating	Hi	1480
	Me+	1420
	Me	1300
	Lo	1110
	Quiet	950
	Cool air prevention	850
	S-Lo	480
Cooling Fan	Hi	1480
	Me	1260
	Lo	1040
	Quiet	850
Dry		850

### (2).FAN OPERATION

The airflow can be switched in 5 steps such as AUTO, QUIET, LOW, MED, HIGH, while the indoor fan only runs.

When Fan mode is set at (Auto), it operates on (MED) Fan Speed.

**(3).COOLING OPERATION**

Switch the airflow [AUTO], and the indoor fan motor will run according to a room temperature, as shown in Figure 6.

On the other hand, if switched in [HIGH] ~ [QUIET], the indoor motor will run at a constant airflow of [COOL] operation modes QUIET, LOW, MED, HIGH, as shown in Table 5.

**(Fig.6)**

airflow change - over ( Cooling:AUTO )

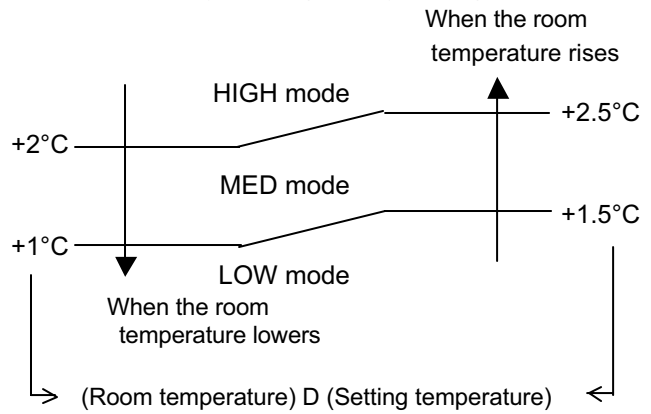

**(4).DRY OPERATION**

Refer to the table 4.

Durring the dry mode operation, the fan speed setting can not be changed.

**(5).HEATING OPERATION**

Switch the airflow [AUTO], and the indoor fan motor will run according to a room temperature, as shown in Figure 7.

On the other hand, if switched [HIGH] ~ [QUIET], the indoor motor will run at a constant airflow of [HEAT] operation modes QUIET, LOW, MED, HIGH, as shown in Table 5.

**(Fig.7)**

airflow change - over ( Heating:AUTO )

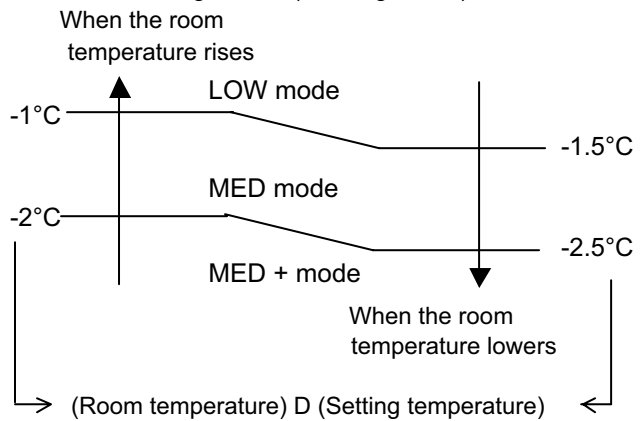

**(6).COOL AIR PREVENTION CONTROL (Heating mode)**

The maximum value of the indoor fan speed is set as shown in Figure 8, based on the detected temperature by the indoor heat exchanger sensor on heating mode.

**(Fig.8 : Cool Air Prevention Control)**

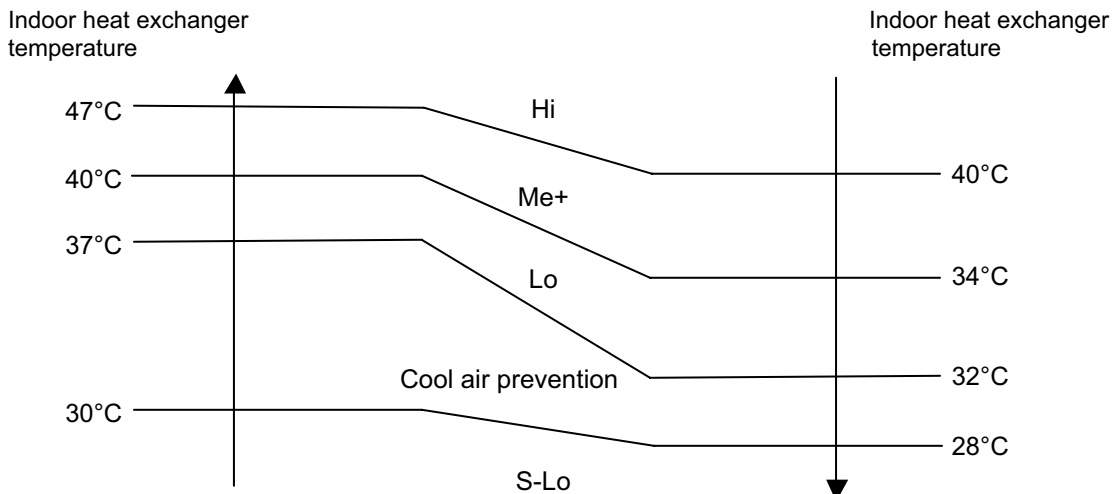

## 6. OUTDOOR FAN CONTROL

### (1). Outdoor Fan Motor

Following table shows the type of the outdoor fan motor. The control method is different between AC motor and DC motor.

( Table 6 : Type of Motor )

	AC Motor	DC Motor
ASYA07/09/12LCC	○	
ASYB09/12LDC		○
ASYA14/18LCC		○

### (2). Fan Speed

( Table 7 : AC Motor )

	Cooling	Dry	Heating
ASYA07/09LCC	830rpm	830rpm	830rpm
ASYA12LCC	820rpm	820rpm	820rpm

\* In conjunction with the compressor ON/OFF, the fan speed operates at around the speed shown above.

( Table 8 : Outdoor fan speed )

(rpm)

	ZONE※	Cooling	Dry	Heating
ASYA14/18LCC	A-D	860/820/670/500	500	820/750/670/550/450
	E	400/340/280	400/280	
	F	280/250/230	200	
ASYB09/12LDC	A-D	800/760/470	500	760/680/470
	E	400/280	400/280	
	F	09LDC: 200 12LDC: 250/200	09LDC: 200 12LDC: 250/200	

※ Refer to Fig1.

\* It runs at 500(A-D ZONE)/200(E,F ZONE) rpm for 20 seconds after starting up the outdoor fan.

\* The outdoor fan speed mentioned above depends on the compressor frequency.  
(When the compressor frequency increases, the outdoor fan speed also changes to the higher speed. When the compressor frequency decreases, the outdoor fan speed also changes to the lower speed.)

\* Outdoor temperature falls, and if it becomes E and F zone(Refer to Fig1), rotations of fan speed will fall.

\* After the defrost control is operated on the heating mode, the fan speed keeps at the higher speed as table 9 without relating to the compressor frequency.

( Table 9 : Outdoor fan speed after the defrost )

	Min
ASYB09LDC	800rpm
ASYB12LDC	900rpm
ASYA14/18LCC	950rpm

# 7. LOUVER CONTROL

## (1). VERTICAL LOUVER CONTROL

(Function Range)

Each time the button is pressed, the air direction range will change as follow:

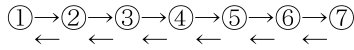

(Fig 9: Air Direction Range)

(Operation Range)

- Cooling / Dry mode : ①—②—③
- Heating mode : ④—⑤—⑥—⑦
- Fan mode : ①—②—③—④—⑤—⑥—⑦

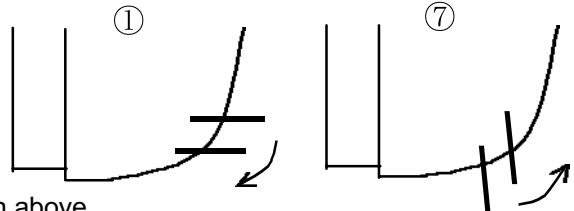

Use the air direction adjustments within the ranges shown above.

- The vertical airflow direction is set automatically as shown, in accordance with the type of operation selected.
  - Cooling / Dry mode : Horizontal flow ①
  - Heating mode : Downward flow ⑦
- When the temperature of the air being blown out is low at the start of heating operation or during defrosting, the airflow direction temporarily becomes ⑦ to prevent cold air being blown onto the body.
- During use of the Cooling and Dry modes, do not set the Air Flow Direction Louver in the Heating range (④~⑦) for long period of time, since water vapor may condense near the outlet louvers and drop of water may drip from the air conditioner. During the Cooling and Dry modes, if the Air Flow Direction Louvers are left in the heating range for more than 30minutes, they will automatically return to position ③.
- During Monitor operation in AUTO CHANGEOVER mode, the airflow direction automatically becomes ①, and it cannot be adjusted.

## (2). SWING OPERATION

When the swing signal is received from the remote controller, the vertical louver starts to swing.

(Swinging Range)

- Cooling mode / Dry mode / Fan mode(①~③) : ① ⇔ ③
- Heating mode / Fan mode(④~⑦) : ③ ⇔ ⑦

- When the indoor fan is either at S-lo or Stop mode, the swinging operation is interrupted and the louver stops at the memorized position.

## 8. COMPRESSOR CONTROL

### (1). OPEARTION FREQUENCY RANGE

The operation frequency of the compressor is different based on the operation mode as shown in the table 10.

(Table 10 : Compressor Operation Frequency Range)

	Cooling		Heating		Dry
	Min	Max	Min	Max	
07/09LCC, 09LDC	18Hz	80Hz	18Hz	130Hz	33Hz
12LCC, 12LDC	18Hz	96Hz	18Hz	130Hz	33Hz
14LCC, 18LCC	18Hz	90Hz	18Hz	119Hz	24Hz

### (2). OPEARTION FREQUENCY CONTROL AT START UP

The compressor frequency soon after the start-up is controlled as shown in the figure 10.

(Fig.10 : Compressor Control at Start-up)

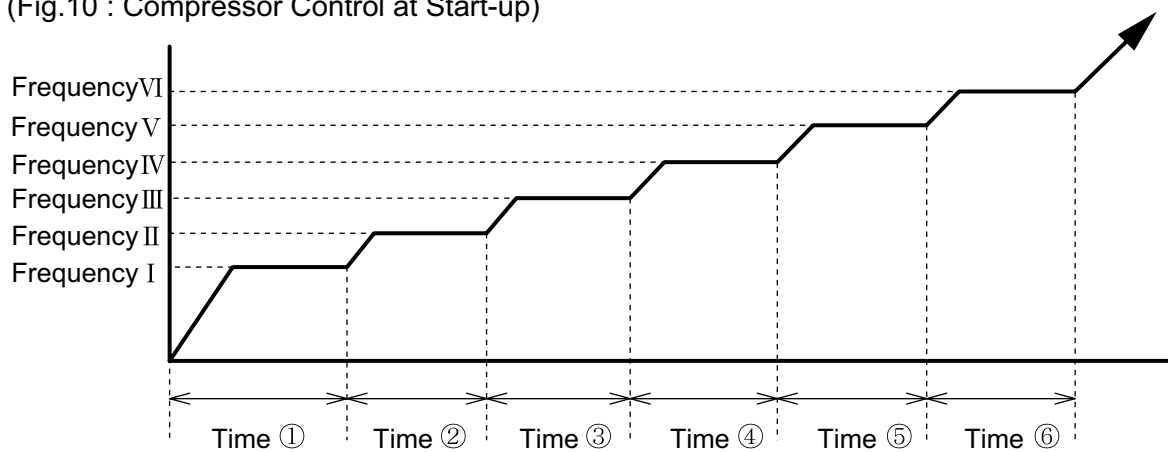

#### (Frequency)

	Frequency I	Frequency II	Frequency III	Frequency IV	Frequency V	Frequency VI
ASYA07/09LCC	56Hz	74Hz	87Hz	97Hz	108Hz	119Hz
ASYA12LCC	56Hz	64Hz	74Hz	87Hz	108Hz	120Hz
ASYB09/12LDC	56Hz	74Hz	87Hz	97Hz	108Hz	119Hz
ASYA14/18LCC	40Hz	59Hz	72Hz	80Hz	101Hz	110Hz

#### (Time)

	Time ①	Time ②	Time ③	Time ④	Time ⑤	Time ⑥
ASYA07/09LCC	80sec	60sec	60sec	180sec	60sec	60sec
ASYA12LCC	80sec	30sec	30sec	30sec	50sec	60sec
ASYB09/12LDC	80sec	60sec	60sec	180sec	60sec	60sec
ASYA14/18LCC	60sec	40sec	40sec	60sec	150sec	60sec

## 9. TIMER OPEARTION CONTROL

The table 11 shows the available timer setting based on the product model.

(Table 11 : Timer Setting)

	ON TIMER / OFF TIMER	PROGRAM TIMER	SLEEP TIMER
ASYA07/09/12/14/18LCC	○	○	○
ASYB09/12LDC	○	○	○

### (1). OPEARTION FREQUENCY RANGE

- OFF timer : When the clock reaches the set time, the air conditioner will be turned off.

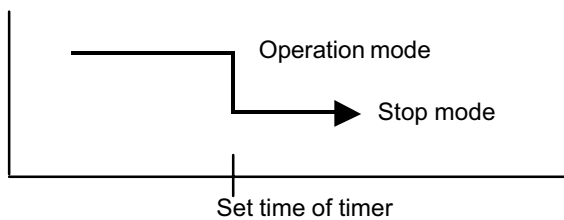

- ON timer : When the clock reaches the set time, the air conditioner will be turned on.

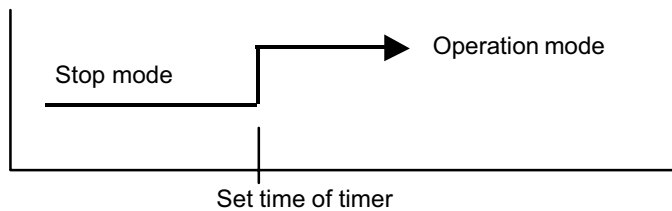

### (2). PROGRAM TIMER

- The program timer allows the OFF timer and ON timer to be used in combination one time.

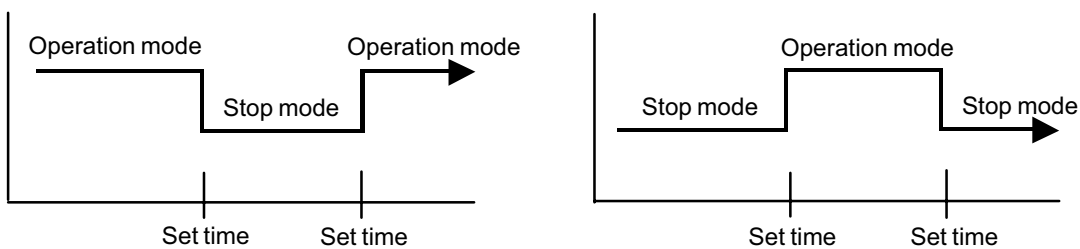

- Operation will start from the timer setting (either OFF timer or ON timer) whichever is closest to the clock's current timer setting. The order of operations is indicated by the arrow in the remote control unit's display.
- SLEEP timer operation cannot be combined with ON timer operation.



### (3). SLEEP TIMER

If the sleep is set, the room temperature is monitored and the operation is stopped automatically. If the operation mode or the set temperature is change after the sleep timer is set, the operation is continued according to the changed setting of the sleep timer from that time ON.

#### In the cooling operation mode

When the sleep timer is set, the setting temperature is increased 1°C.

It increases the setting temperature another 1°C after 1 hour.

After that, the setting temperature is not changed and the operation is stopped at the time of timer setting.

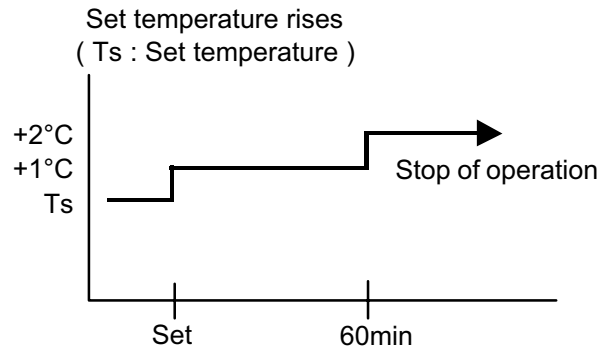

#### In the heating operation mode

When the sleep timer is set, the setting temperature is decreased 1°C.

It decreases the setting temperature another 1°C every 30 minutes.

Upon lowering 4°C, the setting temperature is not changed and the operation stops at the time of timer setting.

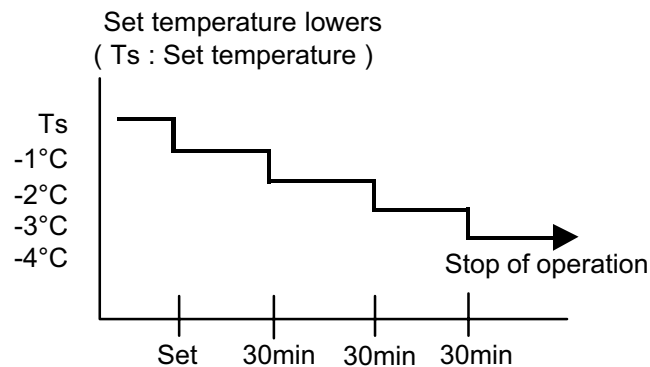

## 10. ELECTRONIC EXPANSION VALVE CONTROL

The most proper opening of the electronic expansion valve is calculated and controlled under the present operating condition based on the following values.

The compressor frequency, the temperatures detected by the discharge temperature sensor, the indoor heat exchanger sensor, the outdoor heat exchanger sensor, and the outdoor temperature sensor.

- \* The pulse range of the electronic expansion valve control is between 60 to 480 pulses.
- \* The expansion valve is set at 480 pulses after 110 seconds of stopping compressor.
- \* At the time of supplying the power to the outdoor unit, the initialization of the electronic expansion valve is operated (528 pulses are input to the closing direction).

## 11. TEST OPERATION CONTROL

Under the condition where the air conditioner runs, press the test operation button of the remote control, and the test operation control mode will appear. During test running, the operation lamp and timer lamp of the air conditioner body twinkle simultaneously. Set the test operation mode, and the compressor will continue to run regardless of whether the room temperature sensor detects. The test operation mode is released if 60 minutes have passed after setting up the test operation.

## 12. PREVENT TO RESTART FOR 3 MINUTES ( 3 MINUTES ST )

The compressor won't enter operation status for 2 minutes and 20 seconds after the compressor is stopped, even if any operation is given.

## 13. FOUR-WAY VALVE EXTENSION SELECT

At the time when the air conditioner is switched from the cooling mode to heating mode, the compressor is stopped, and the four-way valve is switched in 2 minutes and 20 seconds later after the compressor stopped.

## 14. AUTO RESTART

When the power was interrupted by a power failure, etc. during operation, the operation contents at that time are memorized and when power is recovered, operation is automatically started with the memorized operation contents.

When the power is interrupted and recovered during timer operation, since the timer operation time is shifted by the time the power was interrupted, an alarm is given by blinking (7 sec ON/2 sec OFF) the indoor unit body timer lamp.

[Operation contents memorized when the power is interrupted]

- Operation mode
- Set temperature
- Set air flow
- Timer mode and timer time
- Set air flow Direction
- Swing
- Air clean(Only 9/12LDC model)

## 15. MANUAL AUTO OPERATION (Indoor unit body operation)

If MANUAL AUTO Button is set, the operation is controlled as shown in Table 12.  
If the remote control is lost or battery power dissipated, this function will work without the remote control.

(Table 12)

	Manual auto operation	Forced cooling operation
OPERATION MODE	Auto changeover	Cooling
FAN CONT. MODE	Auto	Hi
TIMER MODE	Continuous (No timer setting available)	-
SETTING TEMP.	24°C	Room Temp is not controlled
SETTING LOUVER	Standard	Horizontal
SWING	OFF	OFF

## 16. FORCED COOLING OPERATION

Forced cooling operation is started when pressing MANUAL AUTO button for 10 seconds or more. During the forced cooling operation, it operates regardless of room temperature sensor. Operation LED and timer LED blink during the forced cooling operation. They blink for 1 second ON and 1 second OFF on both operation LED and timer LED (same as test operation). Forced cooling operation is released after 60 minutes of starting operation. The FORCED COOLING OPERATION will start as shown in Table 11.

## 17. COMPRESSOR PREHEATING

When the outdoor heat exchanger temperature is lower than temperature and the heating operation has been stopped for 30 minutes, power is applied to the compressor and the compressor is heated. (By heating the compressor, warm air is quickly discharged when operation is started.) When operation was started, and when the outdoor temperature rises to temperature or greater, preheating is ended.

(Table 13 : Preheating Operation / Release Temperature)

	Temperature I	Temperature II
ASYA07/09/12/14/18LCC	5°C	7°C
ASYA09/12LDC	5°C	7°C

## 18. COIL DRY OR AIR CLEAN OPERATION CONTROL

### (1). COIL DRY OPERATION CONTROL

The coil-dry operation functions by pressing COIL DRY button on the remote controller. The coil-dry operation is consisted of 3 cycles of [Fan operation 3 minutes / Heating operation 2 minutes], and Fan operates for 3 minutes at last before ending the air conditioner operation. (It takes 18 minutes to complete the coil-dry operation.)

### (2). AIR CLEAN OPERATION CONTROL (ASYB09/12LDC model only)

The coil-dry operation functions by pressing AIR CLEAN button on the remote controller. It continues from COIL DRY operation, it turns on electricity to AIR CLEAN UNIT, sterilization is performed for 15 minutes.

Indoor unit fan motor operation under AIR CLEAN operation : The cycle of 480rpm Fixation 5 sec ON / 1 min OFF is repeated.

(It takes 33 minutes to complete the AIR CLEANING operation.)

(Table 14 : COIL-DRY or AIR-CLEAN Operating Functions)

	Indoor Fan Speed		Compressor Frequency	Louver Position	Main Unit Indication
ASYA07/09/12LCC	900rpm	-	36Hz	①	COIL-DRY or
ASYB09/12LDC	900rpm	480rpm	36Hz	①	AIR-CLEAN indication : ON
ASYA14/18LCC	900rpm	-	24Hz	①	Other indication : OFF

## 19. DEFROST OPERATION CONTROL

### (1). CONDITION OF STARTING THE DEFROST OPERATION

The defrost operation starts when the outdoor heat exchanger temperature sensor detects the temperature lower than the values shown in Table 15.

(Table 15 : Condition of starting Defrost Operation)

1 <sup>ST</sup> time defrosting after starting operation		Compressor operating time			
		Less than 20 minutes	20 to 60 minutes	60 minutes to 4 hours	After 4 hours
	ASYA07/09LCC	Does not operate	-9°C	-5°C	-3°C
	ASYA12LCC		-9°C	-5°C	-3°C
	ASYB09/12LDC		-9°C	-5°C	-3°C
	ASYA14/18LCC		-9°C	-5°C	-3°C
Defrosting after 2 <sup>ST</sup> time upon starting operation		Compressor operating time			
		Less than 35 minutes	35 minutes to 4 hours	X	After 4 hours
ASYA07/09LCC	Does not operate	-6°C	-3°C		
ASYA12LCC		-6°C	-3°C		
ASYB09/12LDC		-6°C	-3°C		
ASYA14/18LCC		-6°C	-3°C		

### (2). CONDITION OF THE DEFROST OPERATION COMPLETION

Defrost operation is released when the conditions become as shown in Table 16.

(Table 16 : Defrost Release Condition)

	Release Condition
ASYA07/09/12LCC	Outdoor heat exchanger temperature sensor value is higher than 16°C or Compressor operation time has passed 15 minutes.
ASYB09/12LDC	Outdoor heat exchanger temperature sensor value is higher than 16°C or Compressor operation time has passed 15 minutes.
ASYA14/18LCC	Outdoor heat exchanger temperature sensor value is higher than 10°C or Compressor operation time has passed 15 minutes.

## Defrost Flow Chart

The defrosting shall proceed by the integrating operation time and outdoor heat exchanger temperature as follows.

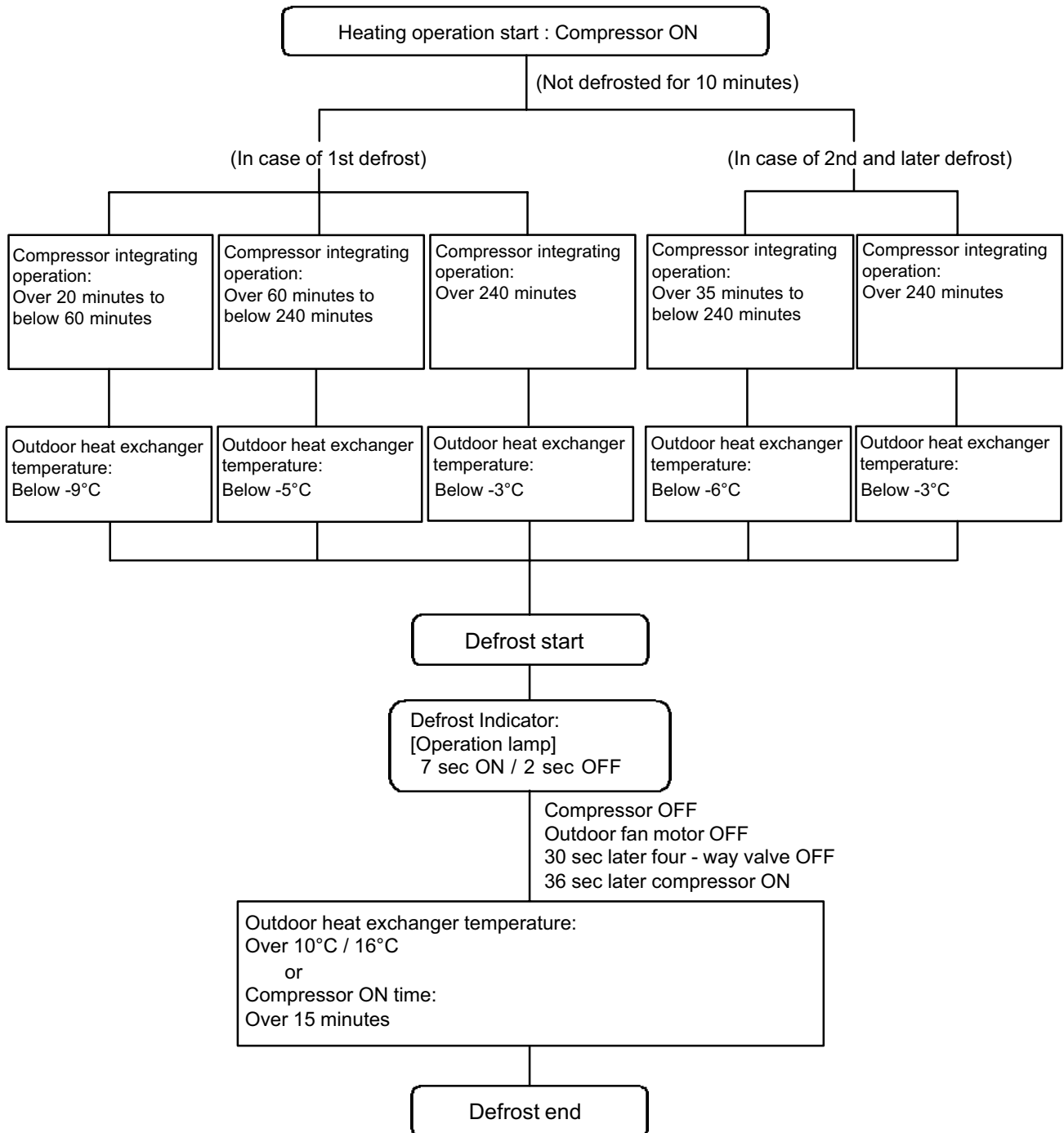

## 20. OFF DEFROST OPERATION CONTROL

When operation stops in the [Heating operation] mode, if frost is adhered to the outdoor unit heat exchanger, the defrost operation will proceed automatically. In this time, if indoor unit operation lamp flashes slowly (7 sec ON / 2 sec OFF), the outdoor unit will allow the heat exchanger to defrost, and then stop.

### (1). OFF DEFROST OPERATION CONDITION

In heating operation, the outdoor heat exchanger temperature is less than  $-4^{\circ}\text{C}$ , and compressor operation integrating time lasts for more than 30 minutes.

### (2). OFF DEFROST END CONDITION

	Release Condition
ASYA07/09/12LCC	Outdoor heat exchanger temperature sensor value is higher than $16^{\circ}\text{C}$ or Compressor operation time has passed 15 minutes.
ASYB09/12LDC	Outdoor heat exchanger temperature sensor value is higher than $16^{\circ}\text{C}$ or Compressor operation time has passed 15 minutes.
ASYA14/18LCC	Outdoor heat exchanger temperature sensor value is higher than $10^{\circ}\text{C}$ or Compressor operation time has passed 15 minutes.

### OFF Defrost Flow Chart

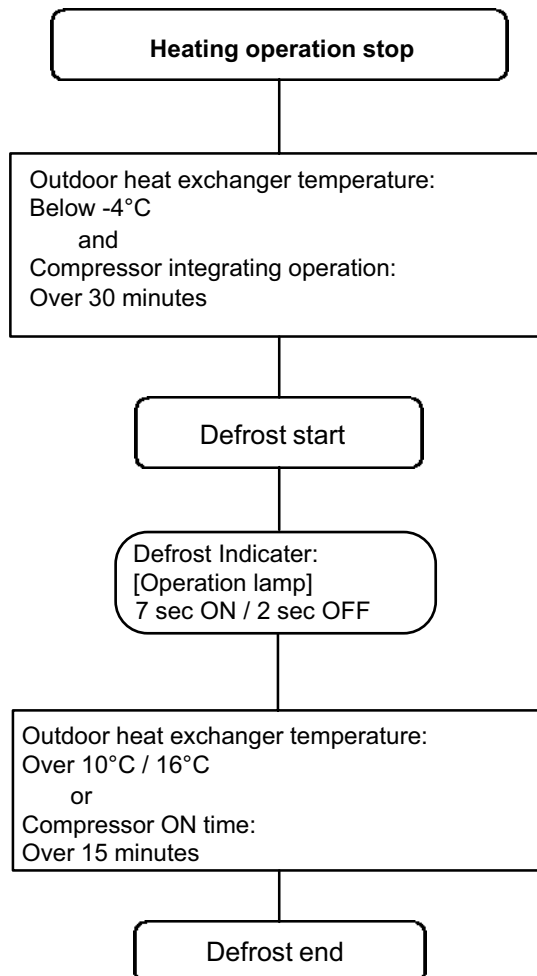

## 21. VARIOUS PROTECTIONS

### (1). DISCHARGE GAS TEMPERATURE OVERRISE PREVENION CONTROL

The discharge gas thermosensor (discharge thermistor : Outdoor side) will detect discharge gas temperature.

When the discharge temperature becomes higher than Temperature I, the compressor frequency is decreased 20 Hz, and it continues to decrease the frequency for 20 Hz every 120 seconds until the temperature becomes lower than Temperature I.

When the discharge temperature becomes lower than Temperature II, the control of the control of the compressor frequency is released.

When the discharge temperature becomes higher than Temperature III, the compressor is stopped and the indoor unit LED starts blinking.

(Table 17 : Discharge Temperature Over Rise Prevention Control / Release Temperature)

	Temperature I	Temperature II	Temperature III
ASYA07/09/12/14/18LCC	104°C	101°C	110°C
ASYB09/12LDC	104°C	101°C	110°C

### (2). CURRENT RELEASE CONTROL

The compressor frequency is controlled so that the outdoor unit input current does not exceeds the current limit value that was set up with the outdoor temperature.

The compressor frequency returns to the designated frequency of the indoor unit at the time when the frequency becomes lower than the release value.

(Table 18 : Current Release Operation Value / Release Value)

**[ Heating ]** OT : Outdoor Temperature

07/09LCC, 09LDC	12LCC, 12LDC	14/18LCC
OT (Control / Release)	OT (Control / Release)	OT (Control / Release)
17°C $\frac{6.5A}{8.0A} / \frac{6.0A}{7.5A}$	17°C $\frac{6.5A}{8.0A} / \frac{6.0A}{7.5A}$	17°C $\frac{7.0A}{9.0A} / \frac{6.5A}{8.5A}$
12°C $\frac{8.0A}{8.0A} / \frac{7.5A}{7.5A}$	12°C $\frac{8.0A}{8.5A} / \frac{7.5A}{8.0A}$	12°C $\frac{9.0A}{10.5A} / \frac{8.5A}{10.0A}$
5°C $\frac{8.0A}{8.0A} / \frac{7.5A}{7.5A}$	5°C $\frac{8.5A}{9.5A} / \frac{8.0A}{9.0A}$	5°C $\frac{10.5A}{13.0A} / \frac{10.0A}{12.5A}$

**[ Cooling / Dry ]** OT : Outdoor Temperature

07/09LCC, 09LDC	12LCC, 12LDC	14/18LCC
OT (Control / Release)	OT (Control / Release)	OT (Control / Release)
46°C $\frac{3.5A}{4.0A} / \frac{3.0A}{3.5A}$	46°C $\frac{4.0A}{5.0A} / \frac{3.5A}{4.5A}$	46°C $\frac{4.5A}{6.0A} / \frac{4.0A}{5.5A}$
40°C $\frac{4.0A}{5.5A} / \frac{3.5A}{5.0A}$	40°C $\frac{5.0A}{6.5A} / \frac{4.5A}{6.0A}$	40°C $\frac{6.0A}{8.5A} / \frac{5.5A}{8.0A}$

### (3). ANTIFREEZING CONTROL (Cooling and Dry mode)

The compressor frequency is decrease on cooling & dry mode when the indoor heat exchanger temperature sensor detects the temperature lower than Temperature I. Then, the anti-freezing control is released when it becomes higher than Temperature II.

(Table 19 : Anti-freezing Protection Operation / Release Temperature)

	Temperature I	Temperature II
A-D	4°C	7°C
E,F	4°C	13°C

### (4). COOLING PRESSURE OVERRISE PROTECTION

When the outdoor unit heat exchange sensor temperature rises to temperature I or greater, the compressor is stopped and trouble display is performed.

(Table 20 : Cooling Pressure Over Rise Protection Function Temperature)

	Temperature I
ASYA07/09/12/14/18LCC	67°C
ASYB09/12LDC	67°C

### (5). HIGH TEMPERATURE RELEASE CONTROL ( HEATING MODE )

On heating mode, the compressor frequency is controlled as following based on the detection value of the indoor heat exchanger temperature sensor.

[ Control System ]  
Indoor heat exchange temperature

	Temp I	Temp II	Temp III	Temp IV
ASYA07/09/12/14/18LCC	55°C	53°C	52°C	50°C
ASYB09/12LDC	55°C	53°C	52°C	50°C

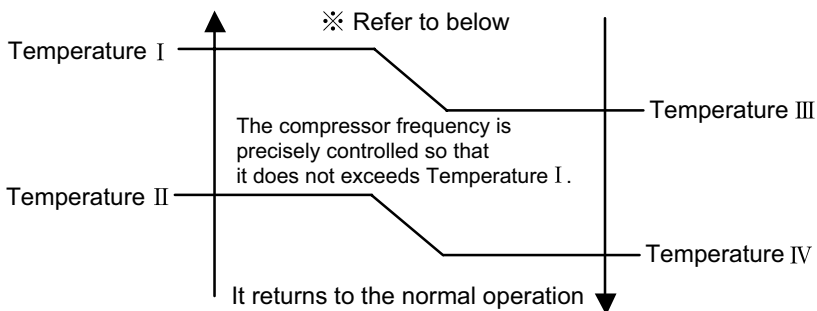

#### ※ Compressor Operation

[ ASYA07/12LCC, ASYB09/12LDC ]

46Hz or greater → 45Hz  
39~45Hz → Frequency down every 120 sec  
26~38Hz → 25Hz  
18~25Hz → OFF

[ ASYA14/18LCC ]

39Hz or greater → 38Hz  
30~38Hz → Frequency down every 120 sec  
19~29Hz → 18Hz  
18Hz → OFF



# ***WALL MOUNTED type INVERTER***

## **6 . REFRIGERANT CAUTION -R410A-**

# 1. R410A TOOLS

This air conditioner used R410A.

For installation and servicing, it is necessary to prepare the tools and machines that are different from the previous refrigerant.

- ⊙ **Mark shows the exclusive use for R410A.**
- ⊙ **Gauge manifold** ..... (Fig.4-1)  
The specification of the gauge is different due to higher pressure.  
The size of connection pipe is also different to prevent mis-use.
- ⊙ **Charge hose** ..... (Fig.4-2)  
Since the normal pressure is high, the connection pipe size is also different.
- ⊙ **Refrigerant cylinder** ..... (Fig.4-3)  
Confirm the refrigerant type before charging. Always charge liquid-phase refrigerant.
- Electronic balance for refrigerant charging** ..... (Fig.4-4)  
Electronic balance is recommended as in the case of R410A.
- ⊙ **Vacuum pump with adapter to prevent reverse flow** ..... (Fig.4-5)  
Conventional pump can be used.
- Vacuum holder** ..... (Fig.4-6)  
Conventional pump can be used if adapter for preventing vacuum pump oil from flowing back is used.
- ⊙ **Gas leakage tester** ..... (Fig.4-7)  
Exclusive for HFC
- Refrigerant cleaner** ..... (Fig.4-8)  
Brown paint as designated by the ARI, USA
- ⊙ **Flare tool** ..... (Fig.4-9)  
The shape of flare is different for high pressure condition.
- ⊙ **Torque wrench** ..... (Fig.4-10)
- ⊙ **Refrigerant recovering equipment (Collector)** ..... (Fig.4-11)  
The type which can be used for any refrigerant is available
- Nitrogen cylinder** ..... (Fig.4-12)  
This prevents an oxide film from forming in the pipe silver-alloy brazing work by turning the air out of the pipe and preventing the inside combustion.
- ⊙ **Safety charger** ..... (Fig.4-13)  
It is always compulsory to change the liquid, because R410A is a mixed refrigerant and there is some fear that a mixing ratio changes. In order to avoid the refrigerant from returning to the compressor in a liquid state, the refrigerant can be charged instead of giving a load to the compressor with a safety charger.
- Control valve** ..... (Fig.4-14)  
The control valve prevents the refrigerant from spouting when it is removed, as the charging hose side and the service port side are possible to open and close at the same time.
- Thermistor vacuum gauge** ..... (Fig.4-15)  
To remove moisture from the refrigerating cycle completely, it is necessary to perform appropriate vacuum drying. For that reason, vacuum conditions can be confirmed certainly.
- Vacuum valve** ..... (Fig.4-16)  
This valve builds in a check valve, and it is easily possible to vacuum a refrigerating cycle or check for degree of vacuum with it.

## TOOLS AND EQUIPMENT (R410A)

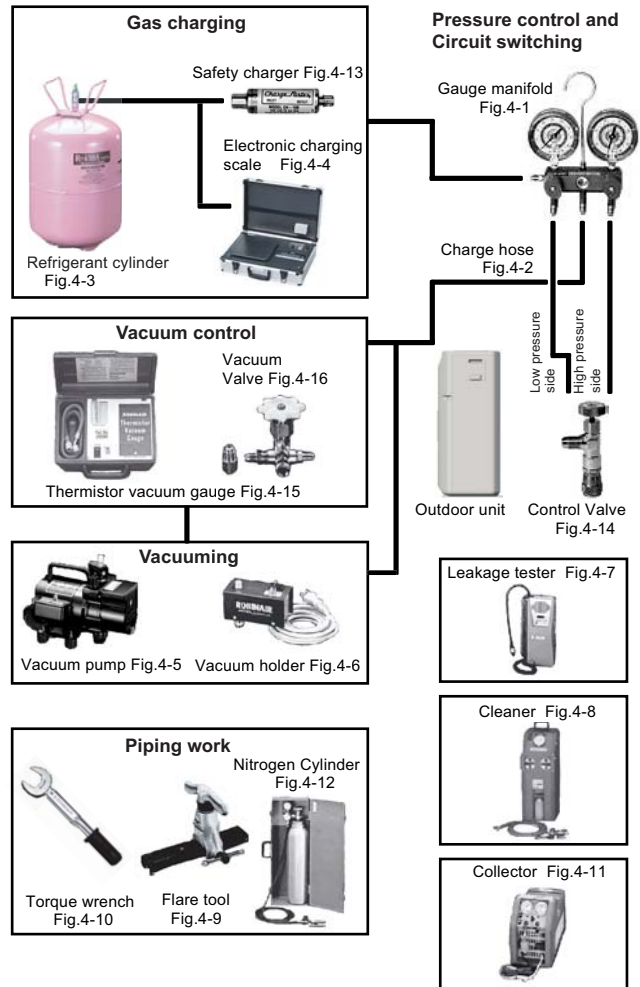

\* 1 Gauge Manifold

	R410A	R22, R407C
High pressure gauge	-0.1~5.3 Mpa	-0.1~3.5 Mpa
Compound gauge	-0.1~3.8 Mpa	-0.1~1.7 Mpa
Port size	1/2UNF 5/16"	7/16UNF 1/4"

\* 2 Charge hose

	R410A	R22, R407C
Normal pressure	5.1 Mpa	3.4 Mpa
Breaking pressure	27.4 Mpa	17.2 Mpa
Port size	1/2UNF	7/16UNF

## 2. PRECAUTION FOR INSTALLATION

Precaution for installation

### Pipe diameter, recommended material and wall thickness

Nominal diameter (in)	1/4"	3/8"	1/2"	5/8"	3/4"	7/8"	1"	1 1/8"	1 1/4"	1 3/8"	1 1/2"
Outside diameter (mm)	6.35	9.52	12.70	15.88	19.05	22.22	25.40	28.58	31.75	34.92	38.10
Material	COPPER JIS H3300-C1220T-O or equivalent <sup>1)</sup>					COPPER JIS H3300-C1220T-H or equivalent <sup>2)</sup>					
Wall thickness <sup>3)</sup> (mm)	0.8	0.8	0.8	1.0	1.2	1.0	1.0	1.0	1.1	1.2	1.3

1) Allowable tensile stress  $\geq 33$  (N/mm<sup>2</sup>); 2) Allowable tensile stress  $\geq 61$  (N/mm<sup>2</sup>); 3) Design pressure 4.2MPa.

The pipe must be properly pressure rated for R410A  
The pipe must be an air-conditioning refrigerant pipe.

### Flare and flare nuts

Diameter	1/4" (6.35mm)		3/8" (9.52mm)		1/2" (12.7mm)		3/8" (15.88mm)		3/4" (19.05mm)	
Refrigerant	R410A	R22 /R407C	R410A	R22 /R407C	R410A	R22 /R407C	R410A	R22 /R407C	R410A	R22 /R407C
A	9.1	9.0	13.2	13.0	16.6	16.2	19.7	19.4	24	23.7
B	13	12	20	15	13	20	25	23	29	29
C	12	11	16	12.5	19	16	22	20	24	24
Nut width	17		22		26	24	29	27	36	

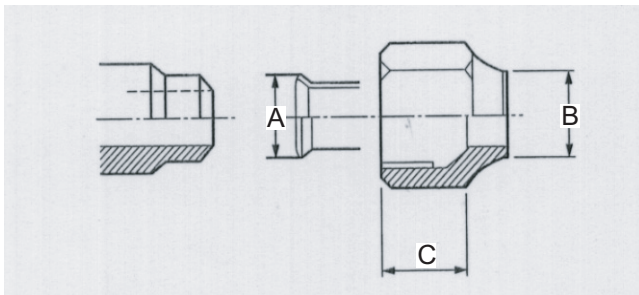

**Always use the flare nut that is packed with the product.**

Do not use existing (for R22) pipes

- Be sure to use new pipes when replacing conventional (R22) model with HFC (R407C, R410A) model.
- If you use existing pipes, it may cause resolution of compressor oil by remaining mineral oil.

## Be careful not to mix moisture and contamination into the pipe

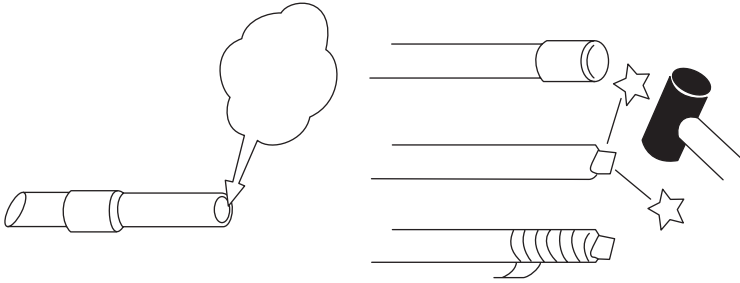

Moisture and contamination in the pipe is a cause of trouble.

## Air purge

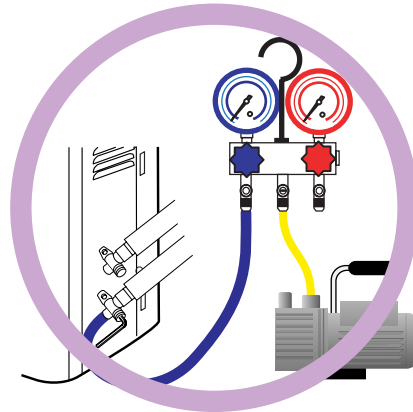
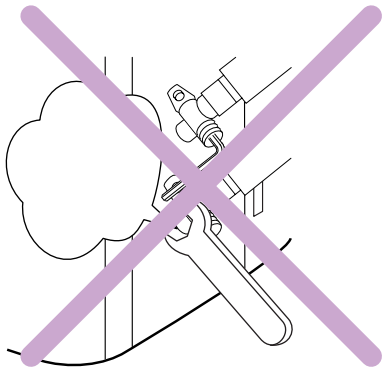

Always use a vacuum pump to purge air.

## Refrigerant charge

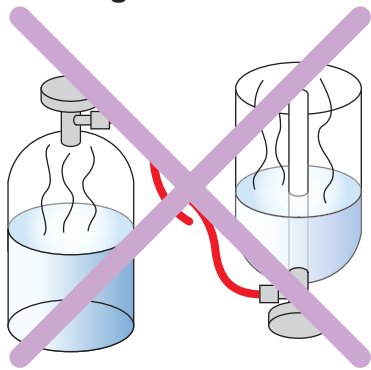

Don't charge from the gas phase side.

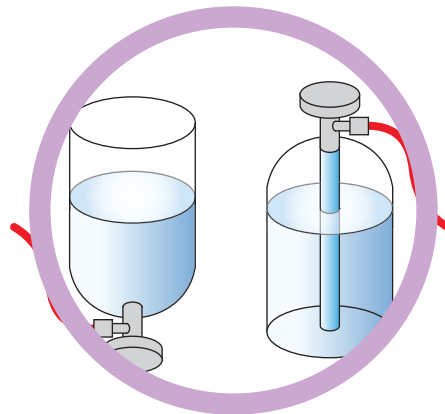

Do it always from the liquid phase side.

## Compressor oil is changed

- We developed new synthetic oil, since HFC refrigerant doesn't dissolve in mineral (for R22)oil.
- Be careful to handle synthetic oil, since it resolves easily by moisture and contamination.
- Don't mix new synthetic oil and mineral oil. It may cause trouble.

### 3. PRECAUTION FOR SERVICING

#### Feature 1 Refrigerant oil is different from before.

<p>Refrigerant oil for New Refrigerant</p> <p><b>Synthetic oil</b> <b>Ether</b> <b>Esther</b></p> <p>※ Previously it was mineral oil.</p>	<p>Different point from previous one</p> <ul style="list-style-type: none"><li>• Absorbent character is high.</li><li>• Contamination occurs when mixed with other kind of oil.</li></ul>	<p>Precaution on Tools</p> <ul style="list-style-type: none"><li>• Use the gauge manifold and charge hose for New Refrigerant(HFC), which shall be segregated from those of R22.</li><li>• Attach the stop valve on the vacuum pump and avoid the oil from reverse flow.</li><li>• It is necessary to use the vacuum pump which can obtain the high vacuum condition.</li></ul>
---	---	---

#### Feature 2 New Refrigerant has Approx 1.6 times higher pressure than previous refrigerant.

<p>R410A</p> <p><b>High Pressure</b></p> <p>※ 1.6 times of R22.</p>	<p>Different point from previous one</p> <ul style="list-style-type: none"><li>• Diameter of Service port has been changed from 1/4 Flare to 5/16 Flare.</li><li>• JIS standard of flare process It became larger</li><li>• To keep the thickness of copper tube. (1/4, 3/8=more than 0.8mm)</li></ul>	<p>Precaution on Tools</p> <ul style="list-style-type: none"><li>• It requires the gauge manifold and charge hose exclusively for R410A.</li><li>• It requires the flare tool and torque wrench that satisfies New JIS standard.</li></ul> <p>※ Previous flare tool + flare adapter can be used as well.</p>
---	--	--

## 4. NEW REFRIGERANT R410A

### \* What is HFC ?

#### Phase-out schedule of HCFC according to Montreal protocol

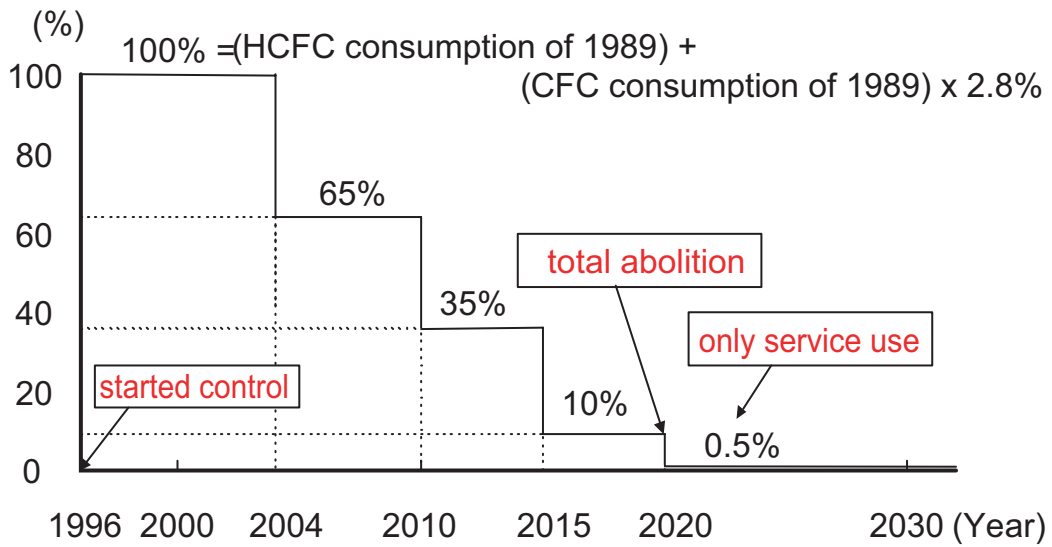

## Ozone Layer depleting mechanism

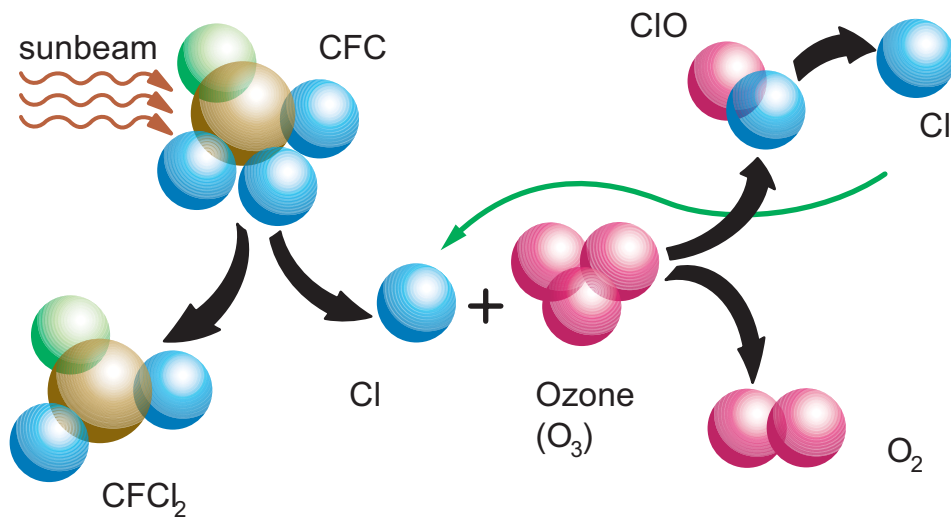

## What is CFC and HCFC?

### CFC : Chloro-Fluoro-Carbon

High ODP( ozone depletion potential ) chemical compound, including chlorine. (ODP:0.6-1.0)  
For example : R12 (for refrigerator and car air-conditioner)

### HCFC : Hydro-Chloro-Fluoro-Carbon

Low ODP chemical compound, including chlorine and hydrogen. (ODP:0.02-01)  
For example : R22 (for air-conditioner)

### HFC<sub>3</sub> : Hydro-Fluoro-Carbon

R134a (for Car air conditioner)  
R407C (for air conditioner)

## Refrigerant characteristics

	R410A	R407C	R22
Composition (wt%)	R32/R125 (50/50)	R32/R125/R134a (23/25/52)	R22 (100)
Boiling Point	- 51.4	- 43.6	- 40.8
Behavior	near azeotrope	zeotrope	---
Pressure at 54.5 °C (kPa)	3,406	2,262	2,151
Temperature Glide (deg)	0.11	5.4	0
ODP	0	0	0.055

## Summary of R407C and R410A characteristics

	R410A	R407C
Advantage	<ul style="list-style-type: none"> <li>• higher system performance</li> <li>• Near-Azeotropic refrigerant</li> </ul>	<ul style="list-style-type: none"> <li>• similar pressure as R22 (possible to design large equipment)</li> </ul>
Disadvantage	<ul style="list-style-type: none"> <li>• 1.6 times higher pressure than R22 (difficult to design against pressure resistance)</li> </ul>	<ul style="list-style-type: none"> <li>• Zeotropic refrigerant (handle with care)</li> </ul>
Suitable for	<ul style="list-style-type: none"> <li>• Small Air-Conditioners</li> </ul>	<ul style="list-style-type: none"> <li>• Large Air-Conditioners</li> </ul>

## \* Designed pressure of R410A refrigerant

Relation between R410A condensing temperature and saturated pressure.

< Pressure → Temp >

Pressure (Mpa)	Temp (°C)
2.20	37.9
2.25	38.7
2.30	39.6
2.35	40.5
2.40	41.3
2.45	42.1
2.55	43.8
2.60	44.6
2.65	45.3
2.70	46.1
2.75	46.8
2.80	47.6
2.85	48.3
2.90	49.0
2.95	49.8
3.00	50.5
3.05	51.2
3.10	51.9
3.15	52.6
3.20	53.2
3.25	53.9
3.30	54.6
3.35	55.3
3.40	55.9
3.45	56.5
3.50	57.1
2.55	57.8
3.60	58.4
3.65	59.0
3.70	59.6
3.75	60.2
3.80	60.8
3.85	61.4
3.90	52.0
3.95	62.5
4.00	63.1
4.05	63.6
4.10	64.2
4.15	64.8

< Temp → Pressure >

Temp (°C)	Pressure (Mpa)
39	2.27
40	2.32
41	2.38
42	2.44
44	2.57
45	2.63
46	2.69
47	2.76
48	2.83
49	2.90
51	3.04
52	3.11
53	3.18
54	3.26
56	3.41
57	3.49
58	3.57
59	3.65
61	3.82
62	3.90
63	3.99
64	4.08



## 5. DIFFERENCE FROM CONVENTIONAL MODEL (R22) AND PRECAUTIONS

### OIL

- Use new synthetic oils such as ester because HFC series refrigerant has less solubility with mineral oils conventionally used for R22.
- As these new synthetic oils are easily influenced by moisture and dusts, they must be treated more carefully than the conventional lubricating oils.

#### CAUTION

For installation/servicing, take more precautions than the case of conventional refrigerants to avoid moisture and dusts entering the refrigerant circuit. Also, for storing parts, more precautions must be taken.

### COMPRESSOR

- Use better grade of material for sliding parts for securing good lubrication of sliding part as HFC refrigerant does not contain chloride.
- Review insulating materials
- Increase pressure resistance strength

#### CAUTION

Check if the compressor is suitable for the refrigerant (model) when replacing. Complete welding within 15 minutes after opening the cap when replacing.

### HEAT EXCHANGER

- Review the water, contaminants controlling level
- Use thinner tube to increase pressure resistance strength (only outdoor unit) improving performance

#### CAUTION

During storage, due care must be taken so that foreign matters such as dust and water do not enter.

### 4-WAY VALVE

- Review materials

#### CAUTION

Check if the valve is suitable for the refrigerant (model) when replacing.

### 2, 3-WAY VALVE

- Review material O-ring, valve core seal for securing suitability with oil.

#### CAUTION

Check if the valve is suitable for the refrigerant (model) when replacing.

# ***WALL MOUNTED type INVERTER***

## **7 . TROUBLE SHOOTING**

1. When the unit does not operate at all (Operation lamp and Timer lamp do not light up)
2. Self Diagnosis Function (Either Operation lamp or Timer lamp is blinking)
  - \* How to operate the self-diagnosis function
  - \* Self- diagnosis table and Check points
3. Trouble shooting method
  - \* Serial signal check
  - \* IPM protection check
  - \* Refrigeration cycle diagnosis

**Does not operate at all (Operation Lamp and Timer Lamp do not light up)**

**[Check Point]**

- (1) Is the input power voltage from the exclusive circuit AC outlet normal?
- (2) Is the AC plug inserted to the AC outlet securely and not loose?
- (3) Does not connected cable do wrong wiring?
- (4) Check if each connector is inserted securely.

[Checking Flow Chart]

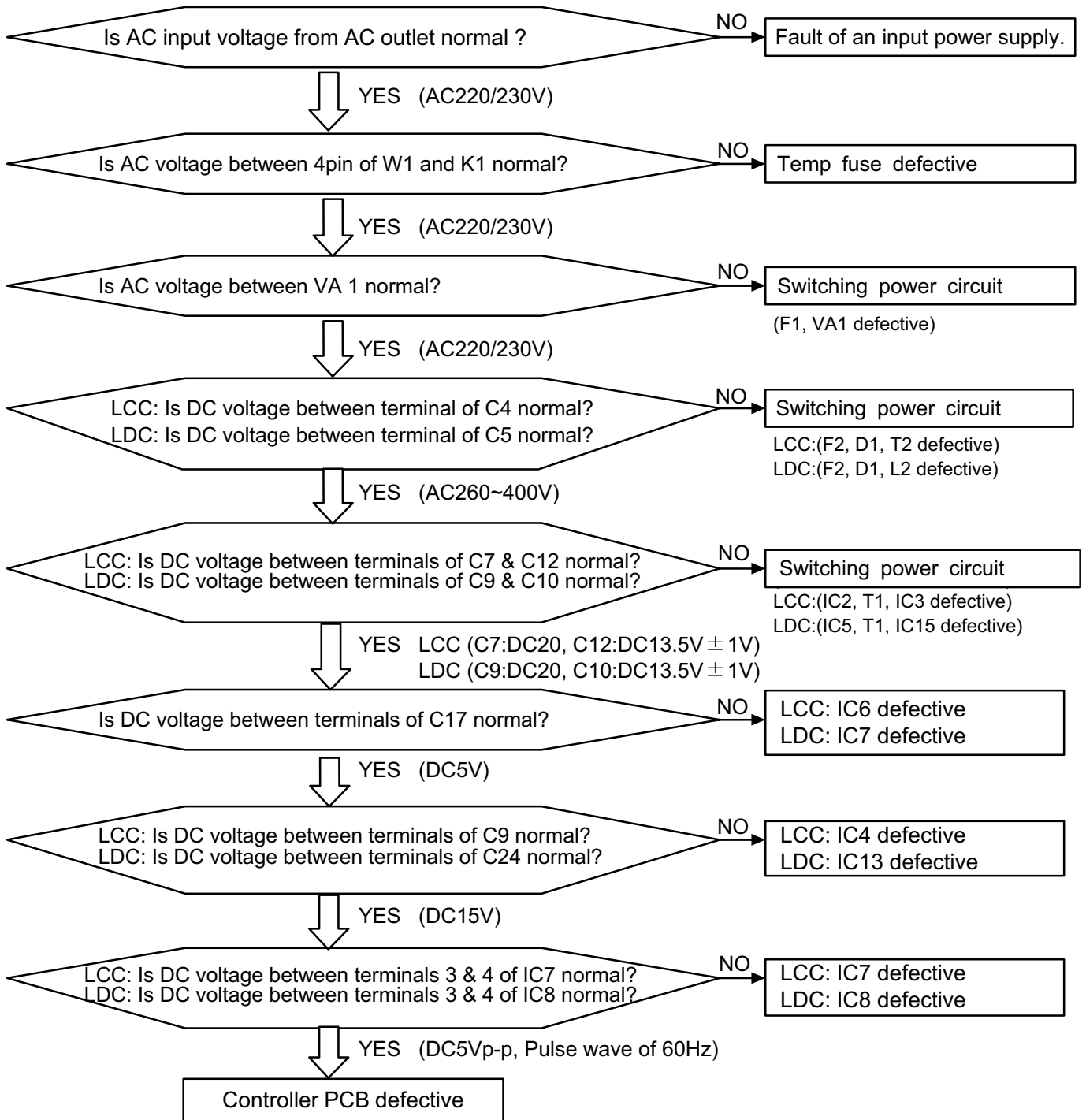

## SELF-DIAGNOSIS FUNCTION

This function memorizes the self-diagnosis function (lamp display) in the indoor control P.C.Board when trouble occurs.

(The memory contents are not destroyed even when the power cord is unplugged from the AC outlet.)

The self-diagnosis function (lamp display) can also be switched between major classification display and minor classification display and precise diagnosis can be made.

### **Self-diagnosis function [lamp display] (memory reading)**

(1) When error occurs, it is indicated by blinking [Operation lamp (Red)] and [Timer lamp (Green)].

(2) Upon pulling out and inserting the AC plug, the starts to operates from remote control.

(At this state, a normal operation indication is performed.)

(3) By pressing [TEST] button of remote control, [Error Indication] is indicated only during

[3 minutes ST].

(3 minutes ST : 2 minutes 20 seconds from the timing AC plug is ON)

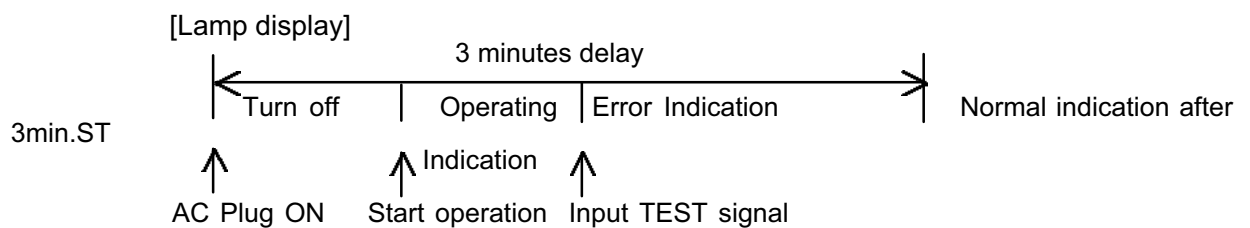

### **How to erase Memory**

(1) While [Error indication] is ON by the self-diagnosis function, the memorized contents can be erased by pressing [Forced Auto Button] on the main unit.

(Indoor unit buzzer beeps 3 seconds.)

## Self - diagnosis function and Checking points

Error Indication		Error (Protection)	Diagnosis Method
Operation (RED)	Timer (GREEN)		
OFF	0.5 sec 2 times	Serial reverse transfer error at starting up operation	At the start up, the indoor unit does not receive the signal for 10 consecutive seconds from the time when the power relay was ON. >Permanent stop after 30 seconds.  [Diagnosis Point] <ul style="list-style-type: none"> <li>• Check the indoor /outdoor cable connection (in order). If the cable wiring is not abnormal, measure the voltage of the outdoor unit terminals and diagnose the defective location. (Refer to the after mentioned [Serial Signal Diagnosis] for the voltage measuring method and diagnosis method.)</li> </ul>
	0.5 sec 3 times	Serial reverse transfer error during the operation	When the indoor unit does not receive the signal for 10 consecutive seconds during the operation >Permanent stop after 30 seconds.  [Diagnosis Point] <ul style="list-style-type: none"> <li>• Check the indoor /outdoor cable connection (in order). If the cable wiring is not abnormal, measure the voltage of the outdoor unit terminals and diagnose the defective location. (Refer to the after mentioned [Serial Signal Diagnosis] for the voltage measuring method and diagnosis method.)</li> </ul>
	0.5 sec 4 times	Serial forward transfer error at starting up operation	The outdoor unit does not receive the signal for 10 consecutive seconds from the time when the power relay was ON. >Outdoor unit stops.  [Diagnosis Point] <ul style="list-style-type: none"> <li>• Check the indoor /outdoor cable connection (in order). If the cable wiring is not abnormal, measure the voltage of the outdoor unit terminals and diagnose the defective location. (Refer to the after mentioned [Serial Signal Diagnosis] for the voltage measuring method and diagnosis method.)</li> </ul>
	0.5 sec 5 times	Serial forward transfer error during the operation	When the outdoor unit does not receive the signal for 10 consecutive seconds during the operation > Outdoor unit stops.  [Diagnosis Point] <ul style="list-style-type: none"> <li>• Check the indoor /outdoor cable connection (in order). If the cable wiring is not abnormal, measure the voltage of the outdoor unit terminals and diagnose the defective location. (Refer to the after mentioned [Serial Signal Diagnosis] for the voltage measuring method and diagnosis method.)</li> </ul>
0.5 sec 2 times	0.5 sec 2 times	Room temperature thermistor defective	The room temperature thermistor detect a abnormal temperature when the power was turned on. > Remote control does not operate.  [Diagnosis Point] <ul style="list-style-type: none"> <li>• Check thermistor resistance value (Refer to "Themistor characteristics table").</li> <li>• Controller PCB defective.</li> </ul>
	0.5 sec 3 times	Indoor heat exchanger thermistor error	The detection value of the indoor heat exchanger thermistor is either open or shorted when the power is ON. > Remote control dose not operate.  [Diagnosis Point] <ul style="list-style-type: none"> <li>• Check thermistor resistance value (Refer to "Themistor characteristics table").</li> <li>• Controller PCB defective.</li> </ul>

## Self - diagnosis function and Checking points

Error Indication		Error (Protection)	Diagnosis Method
Operation (RED)	Timer (GREEN)		
0.5 sec 3 times	0.5 sec 2 times	Discharge thermistor error	<p>The detection value of the discharge thermistor is either open or shorted.                      &gt; Compressor, outdoor fan : OFF (It automatically releases when the normal value is detected.)</p> <p>[Diagnosis Point]</p> <ul style="list-style-type: none"> <li>• Check thermistor resistance value (Refer to "Themistor characteristics table").</li> <li>• Controller PCB defective.</li> </ul>
	0.5 sec 3 times	Outdoor heat exchanger thermistor error	<p>The detection value of the outdoor heat exchanger thermistor is either open or shorted.                      &gt; Compressor, outdoor fan : OFF (It automatically releases when the normal value is detected.)</p> <p>[Diagnosis Point]</p> <ul style="list-style-type: none"> <li>• Check thermistor resistance value (Refer to "Themistor characteristics table").</li> <li>• Controller PCB defective.</li> </ul>
	0.5 sec 4 times	Outdoor temperature thermistor error	<p>The detection value of the outdoor temperature thermistor is either open or shorted.                      &gt; Compressor, outdoor fan : OFF (It automatically releases when the normal value is detected.)</p> <p>[Diagnosis Point]</p> <ul style="list-style-type: none"> <li>• Check thermistor resistance value (Refer to "Themistor characteristics table").</li> <li>• Controller PCB defective.</li> </ul>
0.5 sec 4 times	0.5 sec 2 times	Forced auto switch error	<p>Forced auto switch becomes ON for 30 consecutive seconds.                      &gt; It indicates the error but the operation continues.</p> <p>[Diagnosis Point]</p> <ul style="list-style-type: none"> <li>• Check if forced auto switch is kept pressed.</li> <li>• Forced auto switch defective.</li> <li>• Controller PCB defective.</li> </ul>
	0.5 sec 3 times	Main relay error	<p>After 2 minutes 20 seconds of stopping operation, the signal from outdoor unit is received even though the main relay is OFF.                      &gt; Main relay OFF continues (outdoor unit OFF command)</p> <p>[Diagnosis Point]</p> <ul style="list-style-type: none"> <li>• Main relay defective</li> <li>• Controller PCB defective.</li> </ul>
	0.5 sec 4 times	Power supply frequency detection error	<p>The power supply frequency can not be recognized after 4 seconds of power ON.                      &gt; Permanent stop.</p> <p>[Diagnosis Point]</p> <ul style="list-style-type: none"> <li>• Controller PCB defective.</li> </ul>

### Self - diagnosis function and Checking points

Error Indication		Error (Protection)	Diagnosis Method
Operation (RED)	Timer (GREEN)		
0.5 sec 4 times	0.5 sec 7 times	VDD permanence stop protection (Electric air clean)	When the air cleanness monitor trial protection operates 4 times. > Only clean air permanent stop.  [Diagnosis Point] <ul style="list-style-type: none"> <li>• The front panel is closed.</li> <li>• The foreign body such as dust doesn't adhere.</li> </ul>
	0.5 sec 8 times	Reverde-VDD permanence stop protection (Electric air clean power supply circuit abnormal)	The air clean operation signal was detected for 1 minute at the time of air clean mode OFF. > All stop. Not operate remote controller.  [Diagnosis Point] <ul style="list-style-type: none"> <li>• Electric air clean defective.</li> <li>• Controller PCB defective.</li> </ul>
0.5 sec 5 times	0.5 sec 2 times	IPM protection	Abnormal current value of IPM is detected. > Permanent stop.  [Diagnosis Point] <ul style="list-style-type: none"> <li>• Heat radiation is blocked (inlet/outlet).</li> <li>• Check if outdoor fan is defective (does not rotate).</li> <li>• Controller PCB defective (Refer to after mentioned "IPM diagnosis").</li> <li>• Refrigeration cycle defective (Refer to after mentioned "refrigeration cycle diagnosis").</li> </ul>
	0.5 sec 3 times	CT error	The current value during the operation after 1 minute from starting up the compressor is 0A. > permanent stop.  [Diagnosis Point] <ul style="list-style-type: none"> <li>• Controller PCB defective.</li> </ul>
	0.5 sec 5 times	Compressor location error	The compressor speed does not synchronize with the control signal. (Including start up failure of the compressor). > permanent stop.  [Diagnosis Point] <ul style="list-style-type: none"> <li>• Check if 2-way valve or 3-way valve is left open.</li> <li>• Check the compressor (Winding resistance value, loose lead wire).</li> <li>• Refrigeration cycle defective (Refer to after mentioned "refrigerant cycle diagnosis")</li> </ul>
	0.5 sec 6 times	Outdoor fan error (DC motor)	Either the outdoor fan motor abnormal current or location error was detected. > Permanent stop.  [Diagnosis Point] <ul style="list-style-type: none"> <li>• Fan motor connector loose/ defective contact.</li> <li>• Fan motor defective.</li> <li>• Controller PCB defective.</li> </ul>

## Self - diagnosis function and Checking points

Error Indication		Error (Protection)	Diagnosis Method
Operation (RED)	Timer (GREEN)		
0.5 sec 6 times	0.5 sec 2 times	Indoor fan lock error	The indoor fan speed is 0 rpm after 56 seconds from starting operation or from the time the fan mode was changed. > Operation stop. (It releases by sending the operation stop signal from the remote controller).  [Diagnosis Point] <ul style="list-style-type: none"> <li>• Fan motor connector loose /defective contact.</li> <li>• Fan motor defective</li> <li>• Controller PCB defective.</li> </ul>
	0.5 sec 3 times	Indoor fan speed error	The indoor fan speed is 1/3 of the target frequency after 56 seconds from starting operation or from the time the fan mode was changed. > Operation stop. (It releases by sending the operation stop signal from the remote controller).  [Diagnosis Point] <ul style="list-style-type: none"> <li>• Fan motor connector loose /defective contact.</li> <li>• Fan motor defective</li> <li>• Controller PCB defective.</li> </ul>
0.5 sec 7 times	0.5 sec 2 times	Discharge temperature error	The discharge temperature error is activated. > Permanent stop.  [Diagnosis Point] <ul style="list-style-type: none"> <li>• Check if 2-way valve or 3-way valve is left open.</li> <li>• Heat radiation is blocked (Inlet /outlet).</li> <li>• Check if outdoor fan is defective (does not rotate).</li> <li>• Refrigeration cycle defective (Refer to after mentioned "refrigerant cycle diagnosis").</li> </ul>
	0.5 sec 3 times	Excessive high pressure protection on cooling	Excessive high pressure protection on cooling mode has been activated. > Compressor, outdoor fan : Off (It releases after 3 minute ST).  [Diagnosis Point] <ul style="list-style-type: none"> <li>• Heat radiation is blocked (Inlet /outlet).</li> <li>• Check if outdoor fan is defective (does not rotate).</li> <li>• Refrigeration cycle defective (Refer to after mentioned "refrigerant cycle diagnosis").</li> </ul>
0.5 sec 8 times	0.5 sec 4 times	PFC circuit error	Excessive voltage of DC voltage on PFC circuit in inverter PCB is detected, or the excessive current in the circuit is detected. > Permanent stop.  [Diagnosis Point] <ul style="list-style-type: none"> <li>• Controller PCB defective (Refer to after mentioned "PFC circuit diagnosis")</li> <li>•</li> <li>•</li> </ul>



## Serial Signal Receiving Error

**[Check Point]** Check which has a cause of error, either Indoor unit or Outdoor unit.

- \* Remove indoor unit front panel and cable xlampers and keep the terminal block clear so that it can be measured with a meter.
- \* Remove AC power and reset the power, and press Test Operation switch on remote control.

### [Check Procedure]

**CAUTION: Keep out hands from terminal base and electrical components. Voltage is applied on them and you may get electric shock.**

### [Indoor Unit Check]

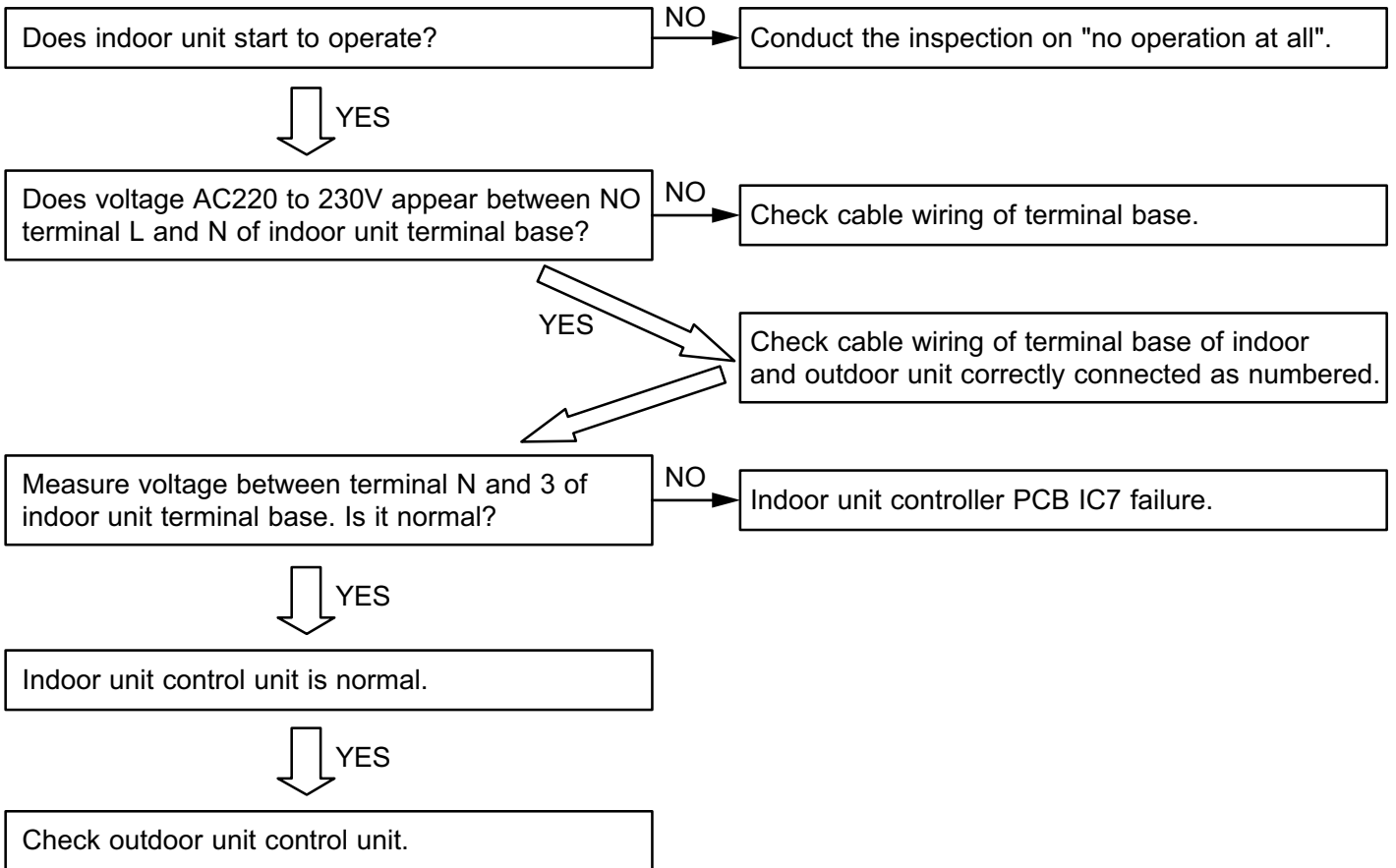

### [Outdoor Unit Check]

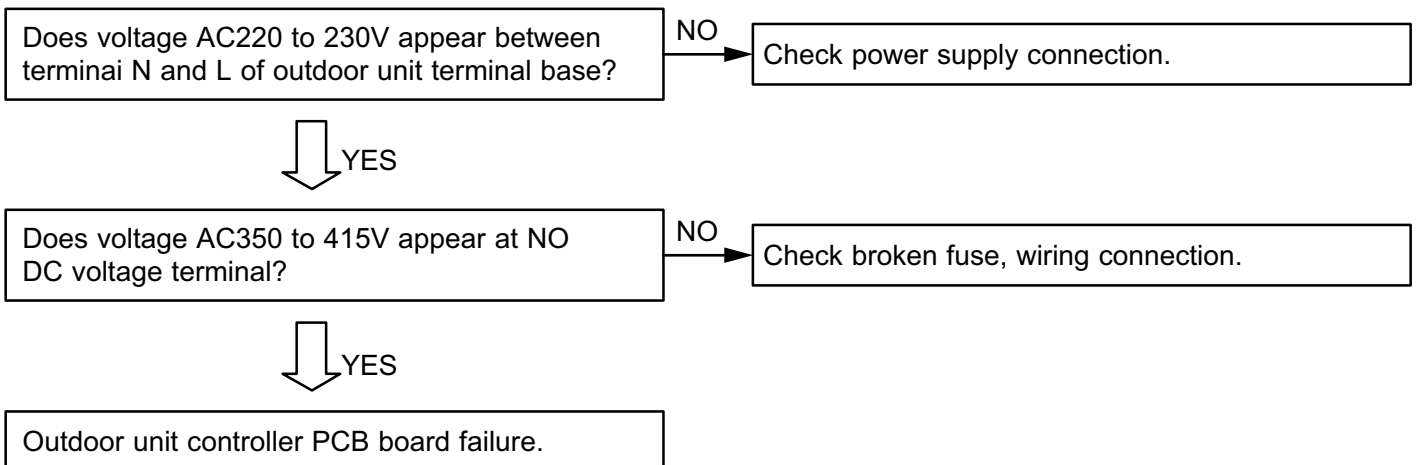

## IPM Protection

### [Checking Points]

Check the following points and locate the cause in the outdoor unit.

### [Cause]

- (1) Compressor failure
- (2) Refrigeration cycle failure
- (3) PC Board defective
- (4) IPM defective
- (5) Incorrect wiring

### [First step]

Measure the DC voltage at terminals (between Electrolytic Capacitor and discharge resistance) in the Inverter Controller Assy, and make sure it is lower than DC5V.

If it is higher than 5V, wait until the discharging is over.

#### Check point (1)

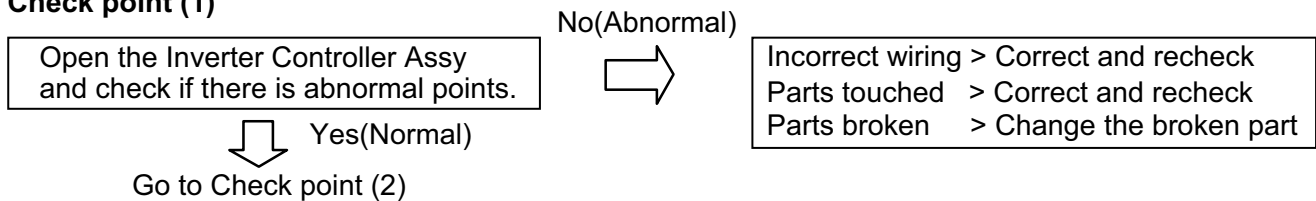

#### Check point (2)

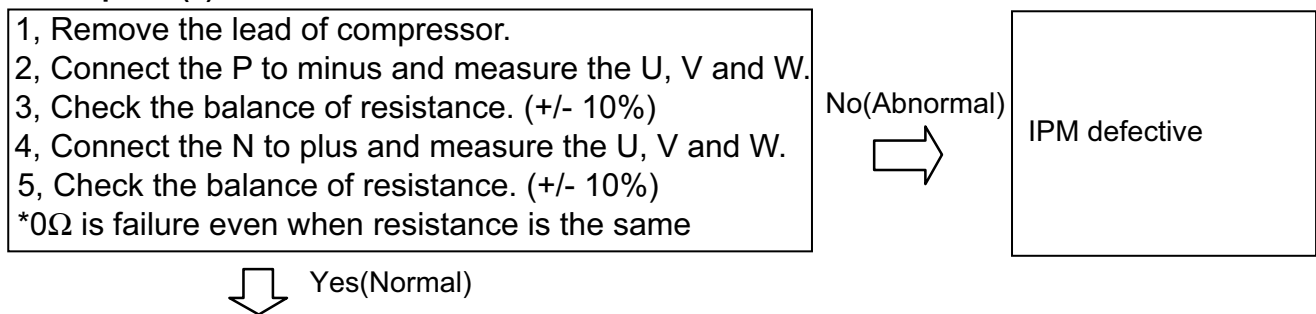

#### Check point (3)

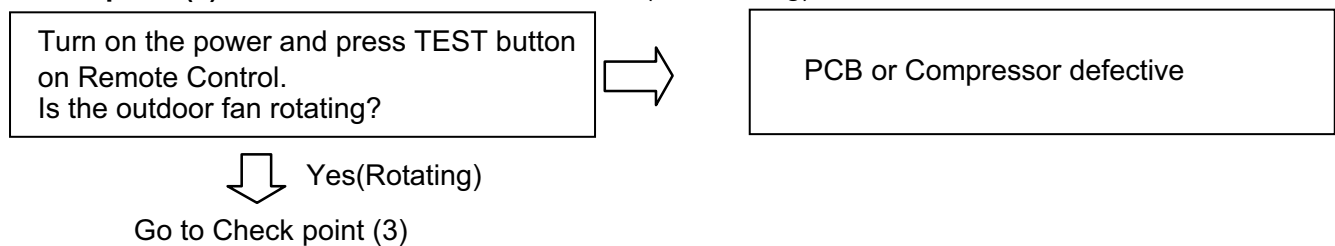

#### Check point (4)

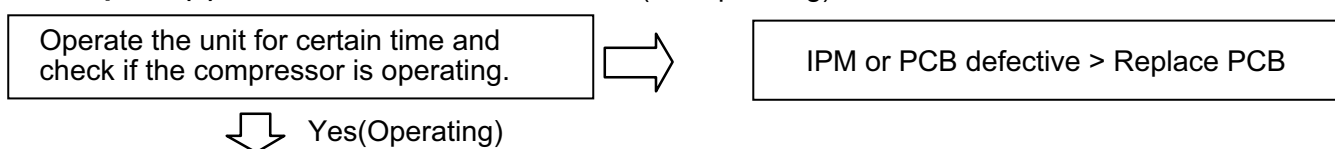

#### Check point (4)

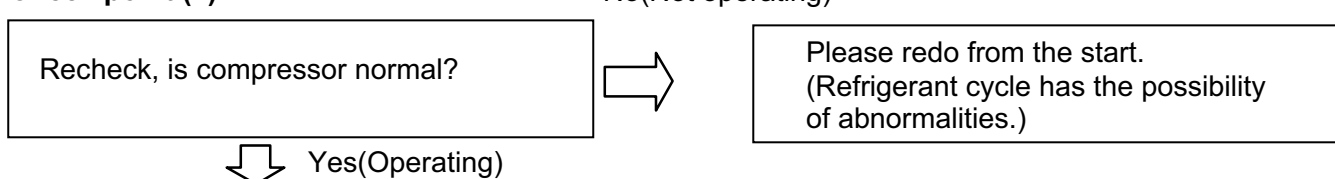

The unit is normal.

## Trouble Shooting of Refrigerant Cycle

[Diagnosis Table for Defective Component]

○: Item of most possible cause

	IPM Protection	Compressor Location error	Discharge Temperature Error	Cooling High Pressure Protection
Refrigerant leak			○	
Compressor failure(*)	○	○		
EEV failure (*)	○	○	○	○
Thermistor failure (*)	○	○	○	○

### (\*) Trouble Shooting Method

#### (1) Checking method of the compressor failure

Insert the AC plug and start up the cooling operation. Input Test operation signal and check if the compressor operates.

If it does not operate, measure the resistance value of compressor windings between U-V, V-W, W-U.

If any of the resistance value between U-V, V-W, W-U is not same as others, the compressor is defective.

#### Compressor Failure

	NORMAL
ASYA07/09/12 LCC	Compressor Case Temperature at 20°C: 0.710 ohm
ASYB09/12LDC	Compressor Case Temperature at 20°C: 0.710 ohm
ASYA14/18LCC	Compressor Case Temperature at 20°C: 0.730 ohm

(The above resistance value is a typical value. There is some distribution. As it also changes by the compressor temperature, the measured value may be much different from the above table when measured right after stopping operation.)

#### (2) Checking method of EEV failure

- Insert the AC plug and start up the operation. Check if the EEV operates just before compressor is turned on. (Touch EEV by hand and check it.)

If it does not operate, check if the coil or connector of EEV is removed or loose.

If it operates, check the discharge thermistor / outdoor heat exchanger thermistor / indoor heat exchanger thermistor. (Refer to (3) for checking method.)

#### (3) Checking method of Thermistor

- Check each thermistor if it is removed or the connector is loose.

If there is no problem, remove the connector of the thermistor from the PCB and check the resistance value (refer to the thermistor characteristics table).

# ***WALL MOUNTED type INVERTER***

## **8 . APPENDING DATA**

1. Jumper setting of Indoor unit and Outdoor unit
2. Outdoor unit Pressure Value and Total Electric Current Curve
3. Thermistor Resistance Values
4. Capacity/Input Data

## JP (Jumper) Setting

### [Indoor Unit]

ASYA07/09/12LCC

ASYB09/12LDC

ASYA14/18LCC

#### - Remote control custom code

When multiple number of indoor units are installed in the same room, erroneous receipt of the signal can be avoided by setting up the remote control custom code separately.

To set up the remote control custom code, always set up the same code on both indoor unit PCB and remote control PCB.

(When the indoor unit PCB is changed to Code B, it can not receive the signal unless remote control PCB is also changed to Code B.)

	Indoor Unit	Remote Control
	JM1 (JP)	J4 (JP)
Code A (Default)	○	○
Code B	×	×

#### - Auto Restart

It is possible to disengage Auto Restart function if it is not needed.

	Indoor Unit
	JM2 (JP)
With Auto Restart function (Default)	○
Without Auto Restart function	×

### [Outdoor Unit]

AOYR07/09/12LCC

		JP			
		JM500	JM103	JM102	JM101
07/09LCC	Normal Preheat	○	○	×	×
	Higher Preheat	×	○	×	×
12LCC	Normal Preheat	○	×	×	×
	Higher Preheat	×	×	×	×

AOYS09/12LDC

		JP			
		JM500	JM103	JM102	JM101
09LDC	Normal Preheat	○	×	×	×
	Higher Preheat	×	×	×	×
12LDC	Normal Preheat	○	×	×	○
	Higher Preheat	×	×	×	○

AOYR14/18LCC

		JP			
		JM500	JM103	JM102	JM101
14LCC	Normal Preheat	○	×	○	×
	Higher Preheat	×	×	○	×
18LCC	Normal Preheat	○	×	○	○
	Higher Preheat	×	×	○	○

- it is possible to select the higher or standard level of preheating function.

- When it is set up at the higher level of preheat, the magnetic noise of the compressor becomes higher.

## Outdoor Unit Low Pressure Value and Outdoor Total Electric Current Curve (Cooling)

**Model Name : ASYA07/09/12LCC**

[Condition]

Ambient Indoor / Outdoor - Same temperature temperature

Refrigerant Standard amount amount

Piping 7.5m (Height difference 1m) length

Power 50Hz - 230V voltage

Operation TEST mode (Cooling), Hi Fan, Horizontal direction, Front air flow condition

Measuring Measure the low pressure with the pressure meter at the service valve. Measure the outdoor unit overall current with the current clamp meter at Power Cable. method

**Caution Start operation with the condition of the Indoor Unit air filter clean.**

[Constant Frequency Operation Method (Test mode)]

1. Operate on Colling mode, and press TEST button of remote control.
2. Operate continuously for 30 minutes. (After 60 minutes of operation, Test mode is released automatically.)

### (1) Indoor/Outdoor Temperature - Outdoor Low Pressure Curve

AS\*9LSACW series

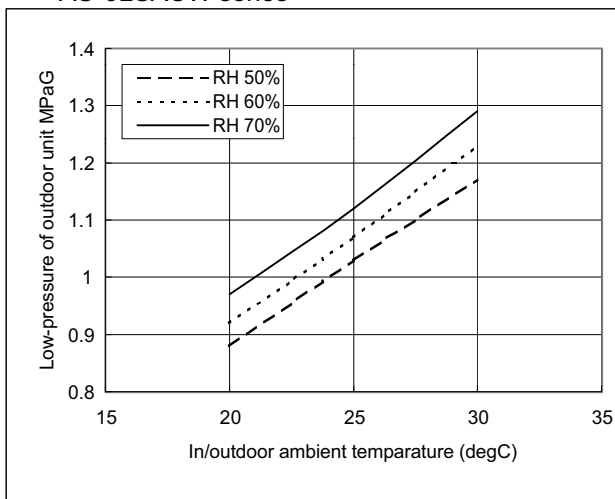

ASYA12LCC

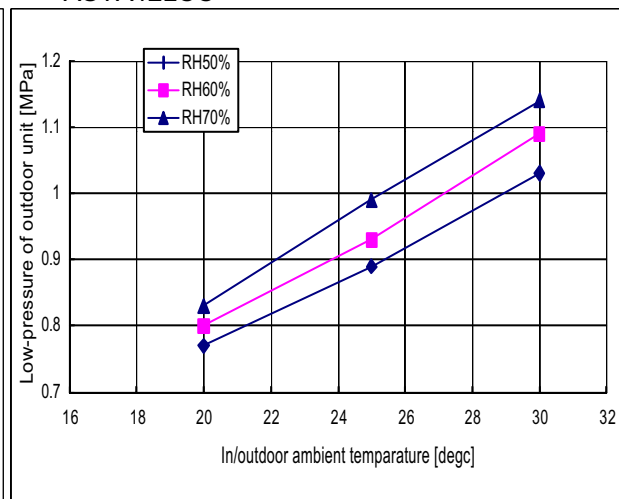

### (2) Indoor/Outdoor Temperature - Outdoor Total Electric Current Curve

AS\*9LSACW series

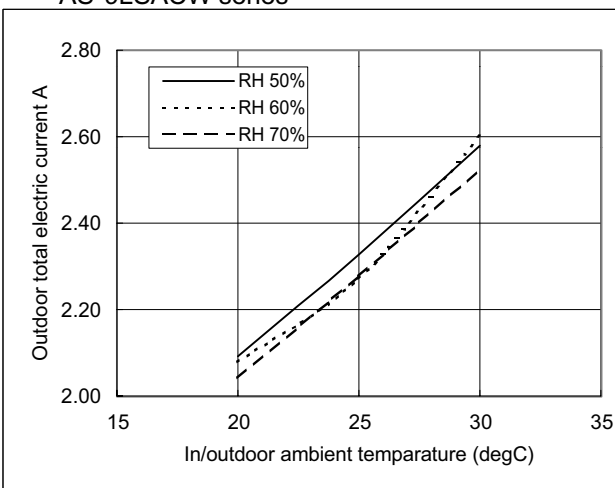

ASYA12LCC

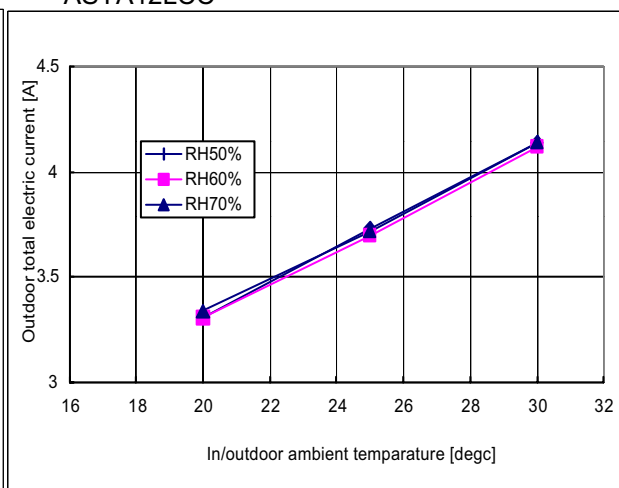

## Outdoor Unit High Pressure Value and Outdoor Total Electric Current Curve (Heating)

**Model Name : ASYA07/09/12LCC**

[Condition]

Ambient Indoor 15 - 23degC, Outdoor 2 - 12degC  
 temperatur

Refrigerant Standard amount  
 amount

Piping 7.5m (Height difference 1m)  
 length

Power 50Hz - 230V  
 voltage

Operation TEST mode (Heating), Hi Fan, Lower direction, Front air flow  
 condition

Measuring outdoor unit overall current with the current clamp meter at Power Cable.  
 method

**Caution Start operation with the condition of the Indoor Unit air filter clean.**

[Constant Frequency Operation Method (Test mode)]

1. Operate on Heating mode, and press TEST button of remote control.
2. Operate continuously for 30 minutes. (After 60 minutes of operation, Test mode is released automatically.)

### (1) Indoor/Outdoor Temperature - Outdoor High Pressure Curve

AS\*9LSACW series

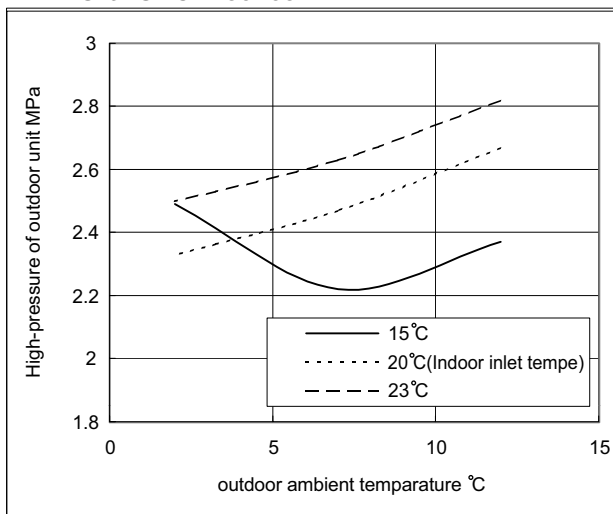

ASYA12LCC

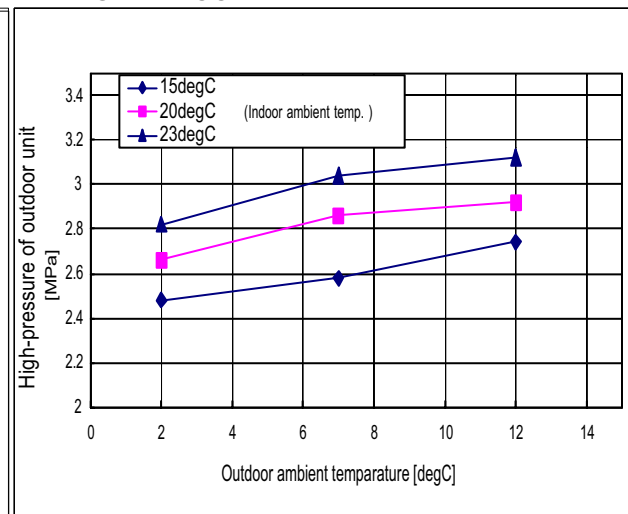

### (2) Indoor/Outdoor Temperature - Outdoor Total Electric Current Curve

AS\*9LSACW series

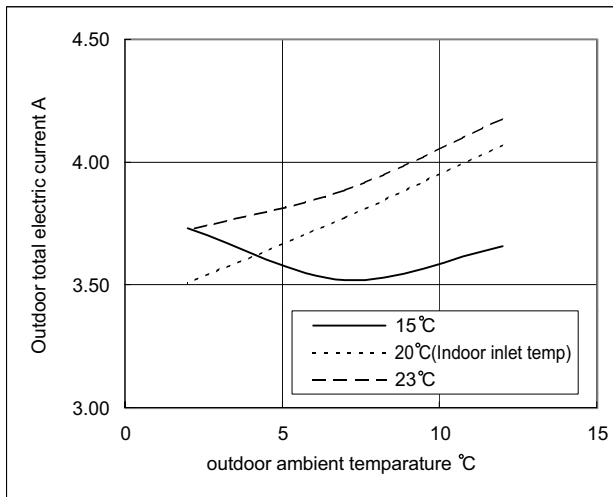

ASYA12LCC

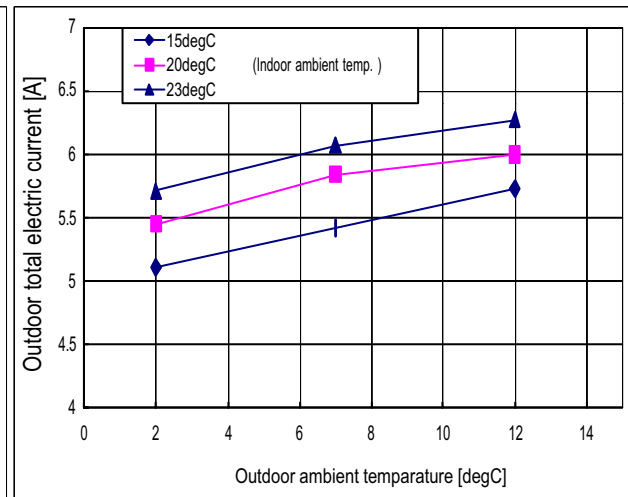

## Outdoor Unit Low Pressure Value and Outdoor Total Electric Current Curve (Cooling)

**Model Name : ASYB09LDC, ASYB12LDC**

[Condition]

Ambient temperature Indoor / Outdoor - Same temperature

Refrigerant amount Standard amount

Piping length 7.5m (Height difference 1m)

Power voltage 50Hz - 230V

Operation condition TEST mode (Cooling), Hi Fan, Horizontal direction, Front air flow

Measuring method Measure the low pressure with the pressure meter at the service valve. Measure the outdoor unit overall current with the current clamp meter at Power Cable.

**Caution Start operation with the condition of the Indoor Unit air filter clean.**

[Constant Frequency Operation Method (Test mode)]

1. Operate on Colling mode, and press TEST button of remote control.
2. Operate continuously for 30 minutes. (After 60 minutes of operation, Test mode is released automatic)

### (1) Indoor/Outdoor Temperature - Outdoor Low Pressure Curve

ASYB09LDC

ASYB12LDC

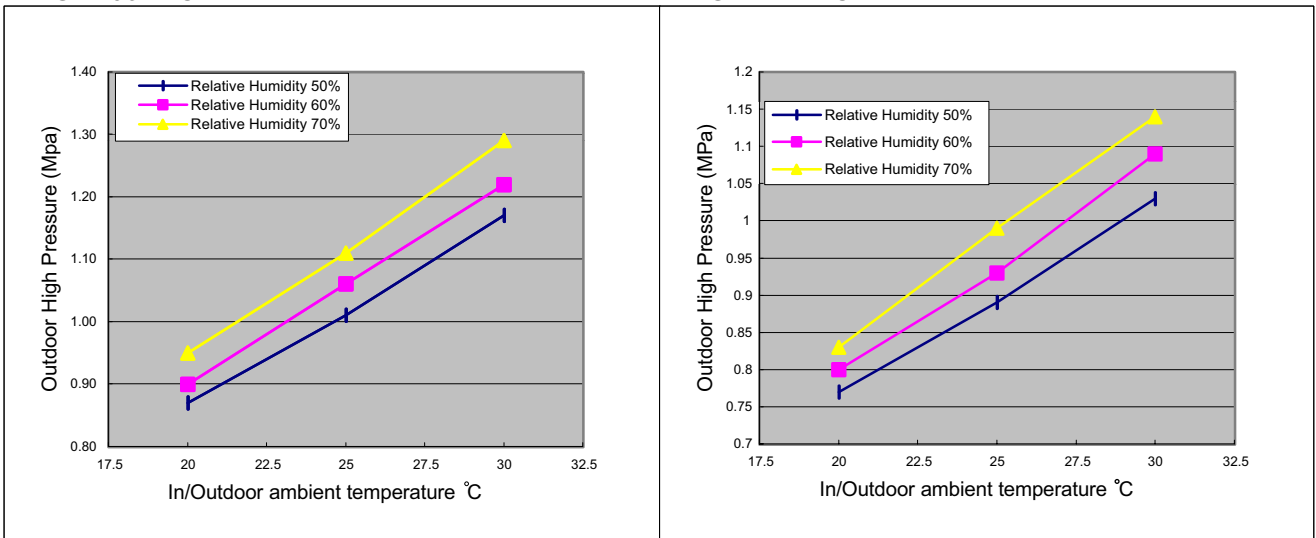

### (2) Indoor/Outdoor Temperature - Outdoor Total Electric Current Curve

ASYB09LDC

ASYB12LDC

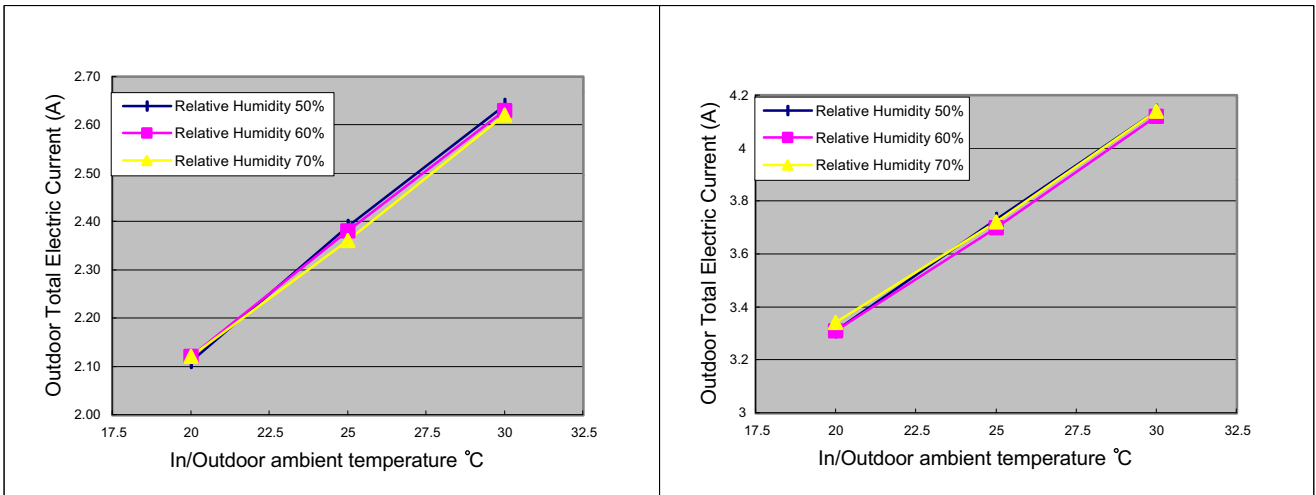



## Outdoor Unit High Pressure Value and Outdoor Total Electric Current Curve (Heating)

**Model Name : ASYB09LDC, ASYB12LDC**

[Condition]

Ambient temperature Indoor 15 - 23degC, Outdoor 2 - 12degC

Refrigerant amount Standard amount

Piping length 7.5m (Height difference 1m)

Power voltage 50Hz - 230V

Operation condition TEST mode (Heating), Hi Fan, Lower direction, Front air flow

Measuring method Measure the high pressure with the pressure meter at the service valve. Measure the outdoor unit overall current with the current clamp meter at Power Cable.

**Caution Start operation with the condition of the Indoor Unit air filter clean.**

[Constant Frequency Operation Method (Test mode)]

1. Operate on Heating mode, and press TEST button of remote control.
2. Operate continuously for 30 minutes. (After 60 minutes of operation, Test mode is released automat

### (1) Indoor/Outdoor Temperature - Outdoor High Pressure Curve

ASYB09LDC

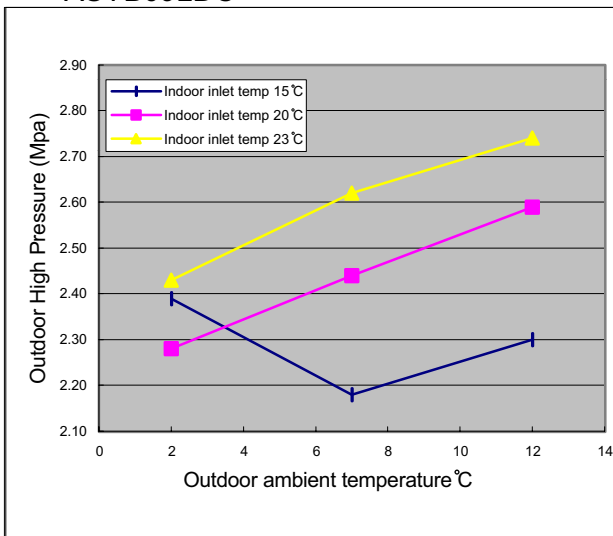

ASYB12LDC

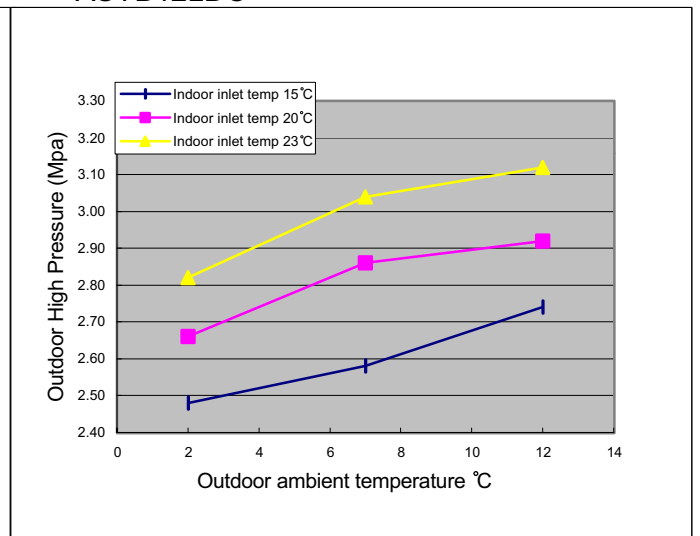

### (2) Indoor/Outdoor Temperature - Outdoor Total Electric Current Curve

ASYB09LDC

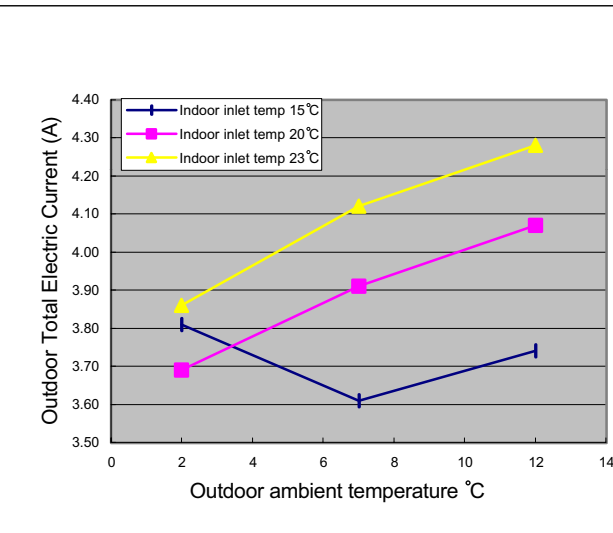

ASYB12LDC

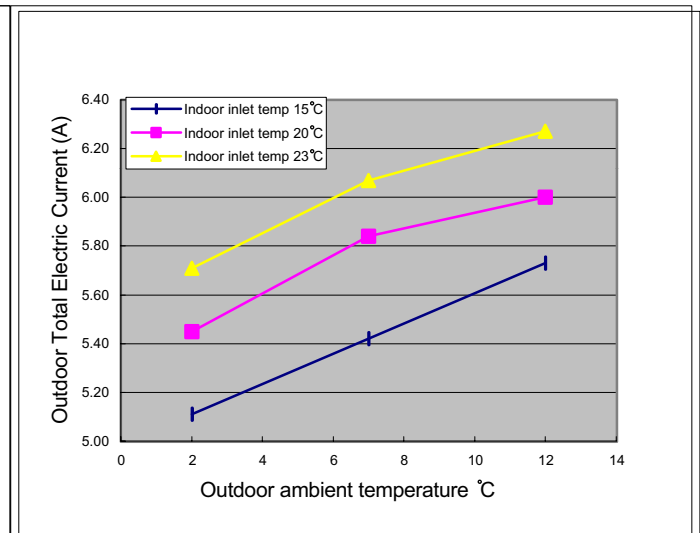

## Outdoor Unit Low Pressure Value and Outdoor Total Electric Current Curve (Cooling)

**Model Name : ASYA14LCC, ASYA18LCC**

[Condition]

Ambient Indoor / Outdoor - Same temperature temperature

Refrigerant Standard amount amount

Piping 7.5m (Height difference 1m) length

Power 50Hz - 230V voltage

Operation TEST mode (Cooling), Hi Fan, Horizontal direction, Front air flow condition

Measuring Measure the low pressure with the pressure meter at the service valve. Measure the outdoor unit overall current with the current clamp meter at Power Cable. method

**Caution Start operation with the condition of the Indoor Unit air filter clean.**

[Constant Frequency Operation Method (Test mode)]

1. Operate on Colling mode, and press TEST button of remote control.
2. Operate continuously for 30 minutes. (After 60 minutes of operation, Test mode is released automatically.)

### (1) Indoor/Outdoor Temperature - Outdoor Low Pressure Curve

ASYA14LCC

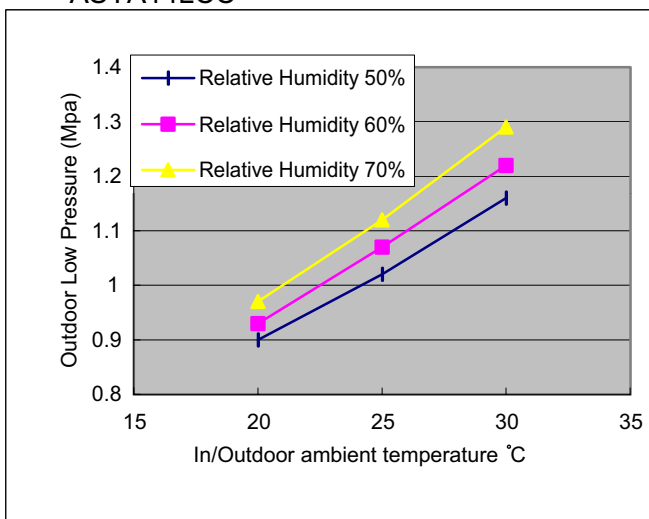

ASYA18LCC

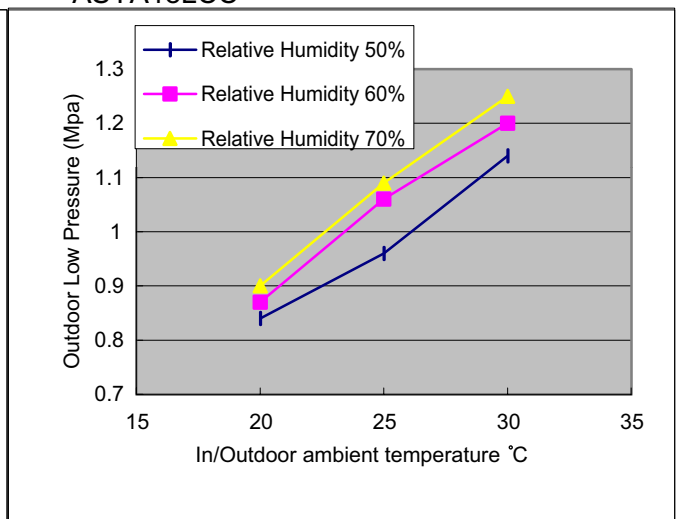

### (2) Indoor/Outdoor Temperature - Outdoor Total Electric Current Curve

ASYA14LCC

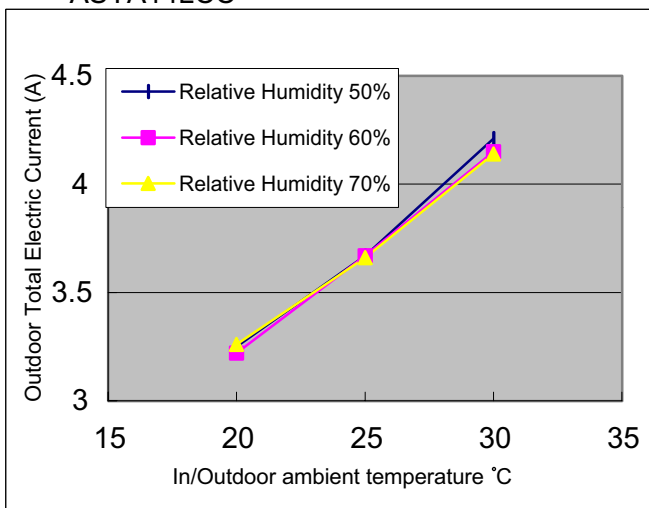

ASYA18LCC

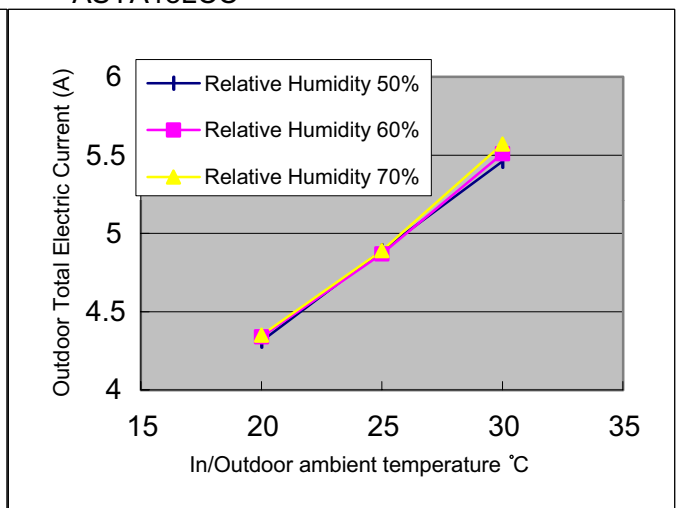

## Outdoor Unit High Pressure Value and Outdoor Total Electric Current Curve (Heating)

**Model Name : ASYA14LCC, ASYA18LCC**

[Condition]

Ambient temperature Indoor 15 - 23degC, Outdoor 2 - 12degC

Refrigerant amount Standard amount

Piping length 7.5m (Height difference 1m)

Power voltage 50Hz - 230V

Operation condition TEST mode (Heating), Hi Fan, Lower direction, Front air flow

Measuring method Measure the high pressure with the pressure meter at the service valve. Measure the outdoor unit overall current with the current clamp meter at Power Cable.

**Caution Start operation with the condition of the Indoor Unit air filter clean.**

[Constant Frequency Operation Method (Test mode)]

1. Operate on Heating mode, and press TEST button of remote control.
2. Operate continuously for 30 minutes. (After 60 minutes of operation, Test mode is released automatically.)

### (1) Indoor/Outdoor Temperature - Outdoor High Pressure Curve

ASYA14LCC

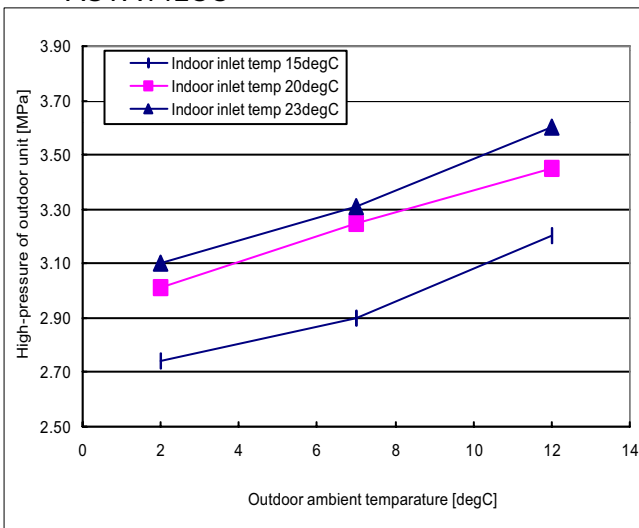

ASYA18LCC

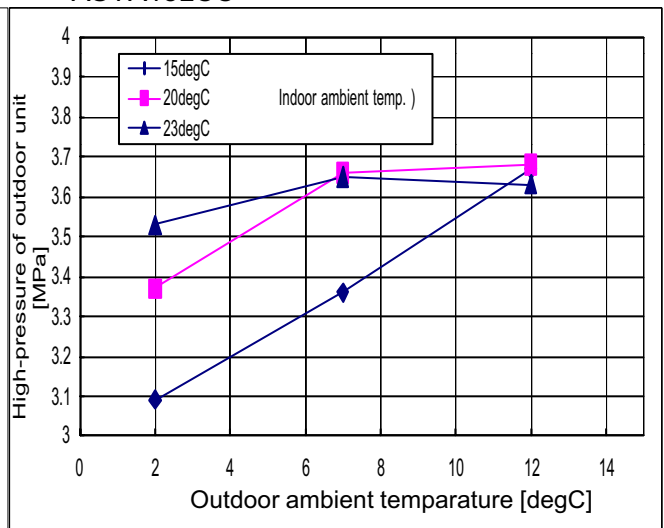

### (2) Indoor/Outdoor Temperature - Outdoor Total Electric Current Curve

ASYA14LCC

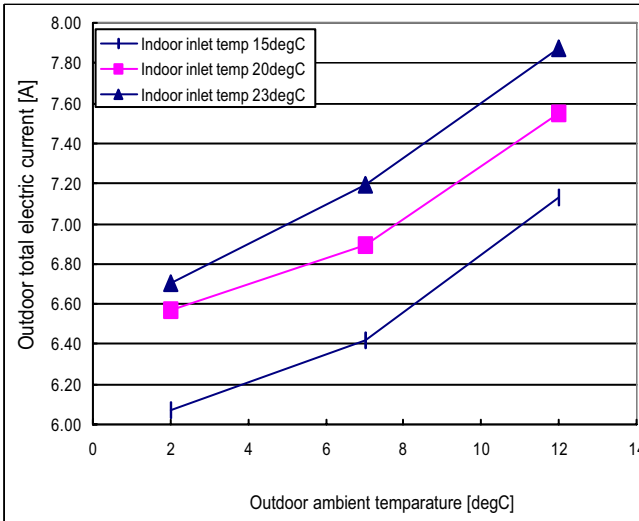

ASYA18LCC

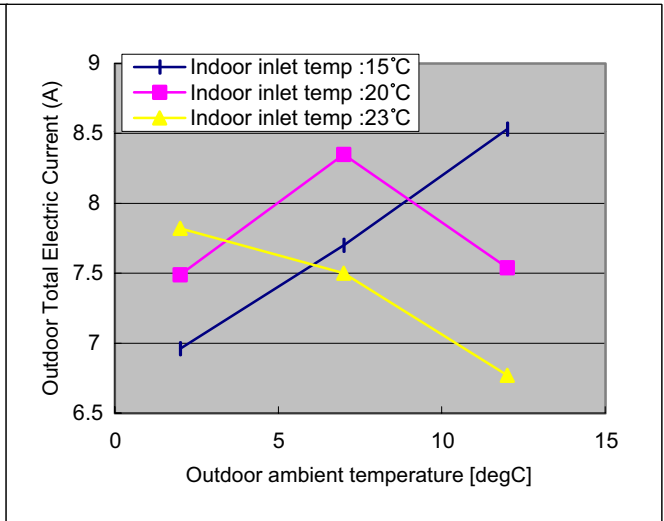

## Thermistor resistance values

Room temperature thermistor		
Temp (°C)	Resistance(k $\Omega$ )	Voltage(V)
0.00	33.62	1.15
5.00	25.93	1.39
10.00	20.18	1.66
15.00	15.84	1.94
20.00	12.54	2.22
25.00	10.00	2.50
30.00	8.04	2.77
35.00	6.51	3.03
40.00	5.30	3.27
45.00	4.35	3.48
50.00	3.59	3.68
55.00	2.98	3.85
60.00	2.47	4.00
65.00	2.09	4.14
70.00	1.76	4.25
75.00	1.49	4.35
80.00	1.27	4.44
85.00	1.09	4.51
90.00	0.93	4.57
95.00	0.81	4.63
100.00	0.70	4.67

Indoor heat exchanger thermistor		
Temp (°C)	Resistance(k $\Omega$ )	Voltage(V)
0.00	176.03	1.10
5.00	134.23	1.36
10.00	103.34	1.63
15.00	80.28	1.92
20.00	62.91	2.21
25.00	49.70	2.51
30.00	39.57	2.79
35.00	31.74	3.06
40.00	25.64	3.30
45.00	20.85	3.53
50.00	17.06	3.73
55.00	14.10	3.90
60.00	11.64	4.55
65.00	9.69	4.19
70.00	8.12	4.30
75.00	6.83	4.40
80.00	5.78	4.48
85.00	4.91	4.55
90.00	4.19	4.61
95.00	3.59	4.66
100.00	3.09	4.71

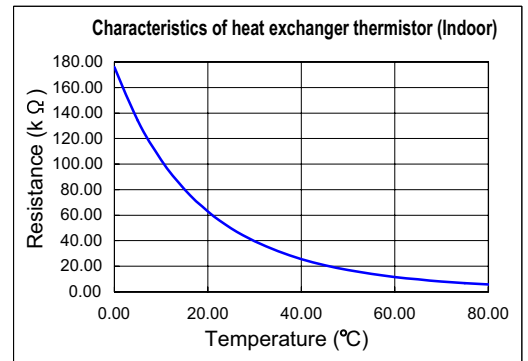
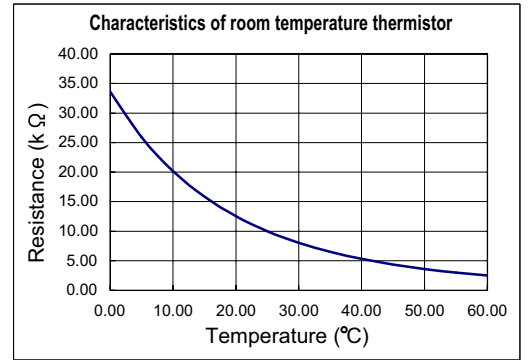

Discharge thermistor		
Temp (°C)	Resistance(k $\Omega$ )	Voltage(V)
0.00	175.70	0.18
5.00	134.93	0.24
10.00	104.59	0.30
15.00	81.79	0.31
20.00	64.50	0.38
25.00	51.27	0.47
30.00	41.07	0.70
35.00	33.13	0.84
40.00	26.91	0.99
45.00	22.01	1.16
50.00	18.10	1.34
55.00	14.98	1.54
60.00	12.47	1.74
65.00	10.44	1.95
70.00	8.78	2.16
75.00	7.42	2.36
80.00	6.31	2.57
85.00	5.38	2.76
90.00	4.61	2.95
95.00	3.97	3.13
100.00	3.43	3.30
105.00	2.98	3.45
110.00	2.59	3.60
115.00	2.26	3.73
120.00	1.99	3.85

Outdoor heat exchanger thermistor		
Temp (°C)	Resistance(k $\Omega$ )	Voltage(V)
-20.00	49.20	2.66
-15.00	36.58	3.02
-10.00	27.51	3.35
-5.00	20.91	3.64
0.00	16.05	3.89
5.00	12.44	4.09
10.00	9.73	4.26
15.00	7.67	4.40
20.00	6.10	4.51
25.00	4.89	4.60
30.00	3.95	4.67
35.00	3.21	4.73
40.00	2.62	4.78
45.00	2.16	4.81
50.00	1.79	4.85
55.00	1.49	4.87
60.00	1.25	4.89
65.00	1.05	4.91
70.00	0.89	4.92
75.00	0.76	4.93
80.00	0.65	4.94
85.00	0.56	4.95
90.00	0.48	4.96
95.00	0.41	4.96
100.00	0.36	4.97

Outdoor temperature thermistor		
Temp (°C)	Resistance(k $\Omega$ )	Voltage(V)
-20.00	115.24	1.25
-15.00	84.21	1.56
-10.00	62.28	1.90
-5.00	46.58	2.26
0.00	35.21	2.61
5.00	26.88	2.94
10.00	20.72	3.25
15.00	16.12	3.52
20.00	12.64	3.76
25.00	10.00	3.97
30.00	7.97	4.14
35.00	6.40	4.28
40.00	5.18	4.41
45.00	4.21	4.51
50.00	3.45	4.59
55.00	2.85	4.65
60.00	2.36	4.71
65.00	1.97	4.76
70.00	1.65	4.79
75.00	1.39	4.83
80.00	1.18	4.85
85.00	1.00	4.87
90.00	0.85	4.89
95.00	0.73	4.91
100.00	0.63	4.92

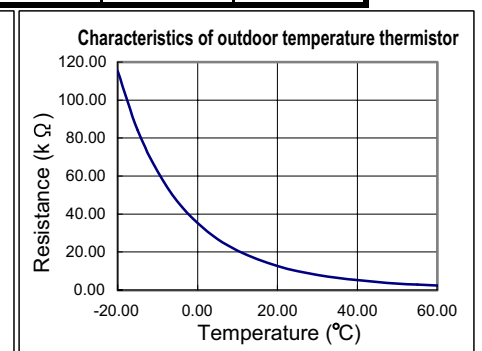
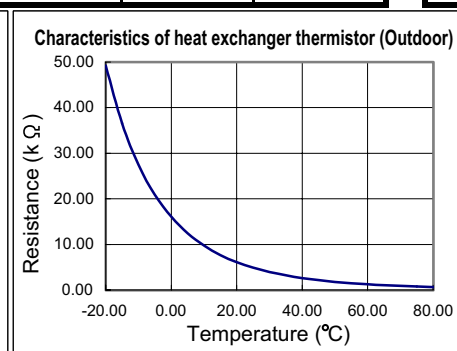
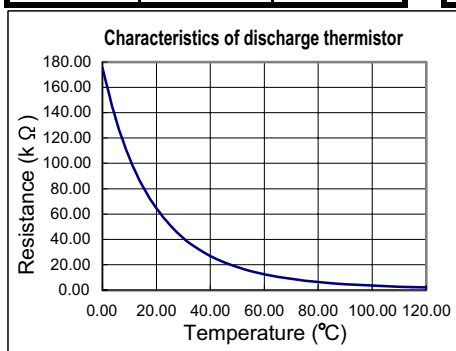

## Heating

### < Capacity >

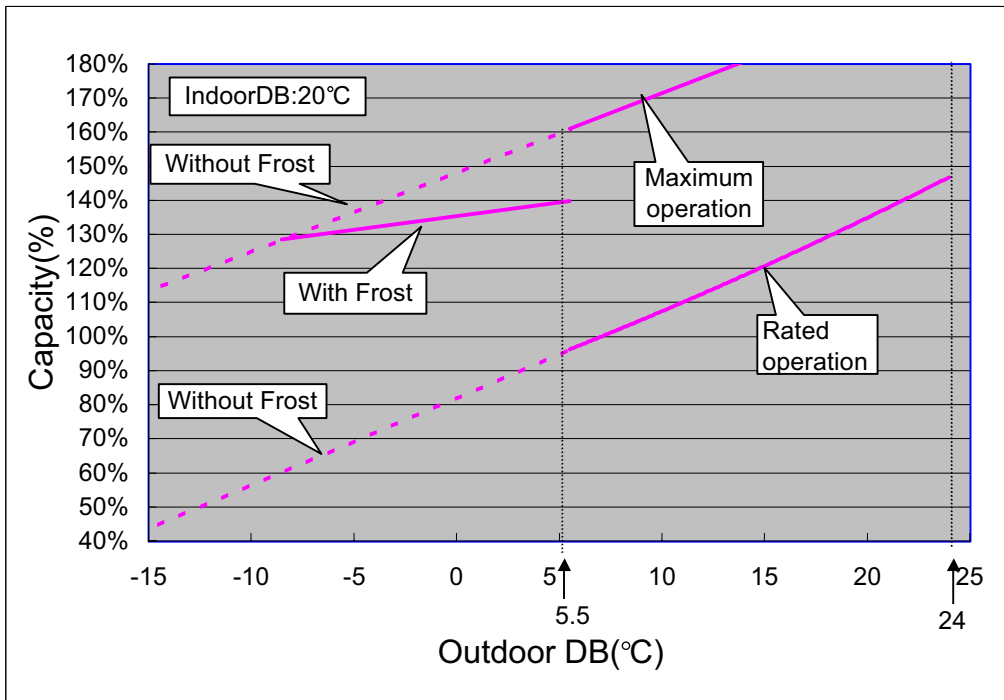

### < Input >

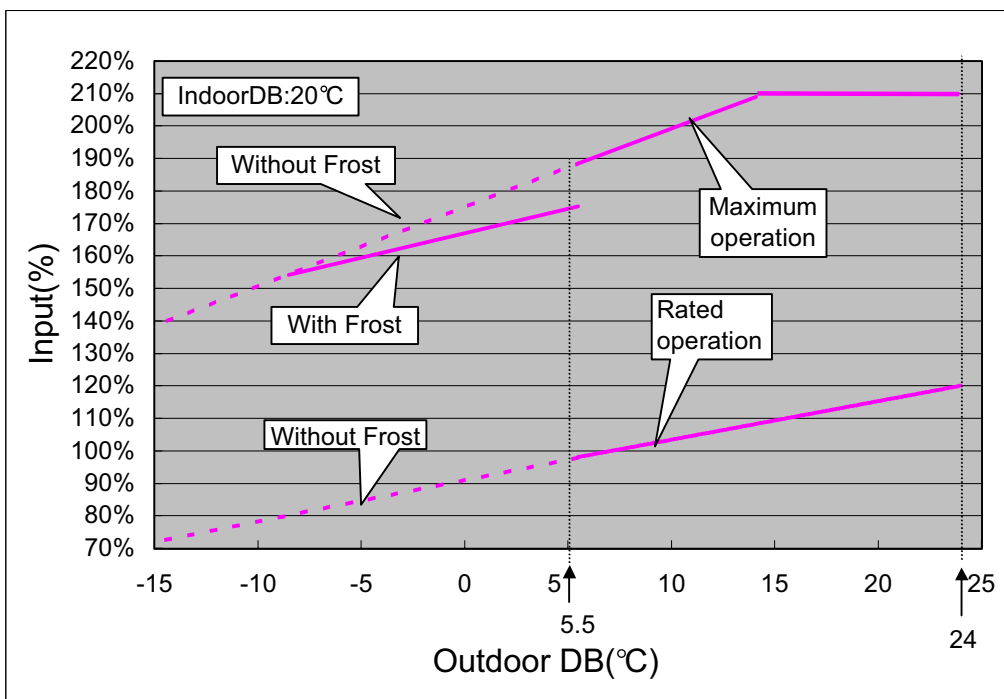

\*Defrosting operation is performed when temperature is less than 5.5 degrees C.

Frost appears on an outdoor unit heat exchanger at 5.5 or less degrees C.

\*Solid line: Integral capacity/Input containing the defrosting cycle.

\*Dotted line: Capacity/Input which does not contain the defrosting cycle.

# Cooling

## < Capacity >

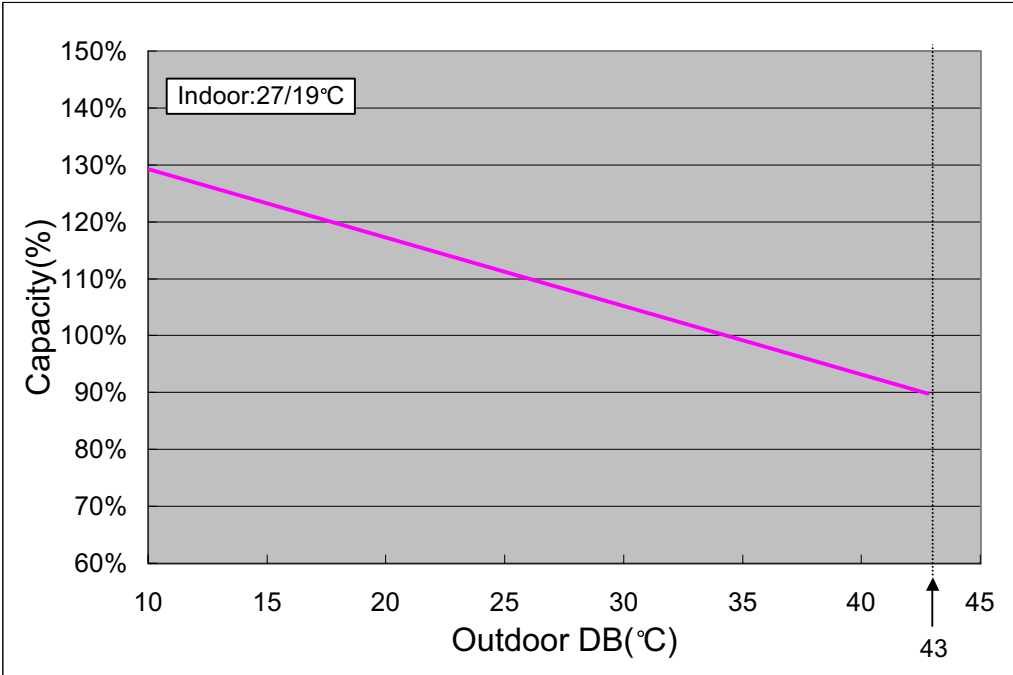

## < Input >

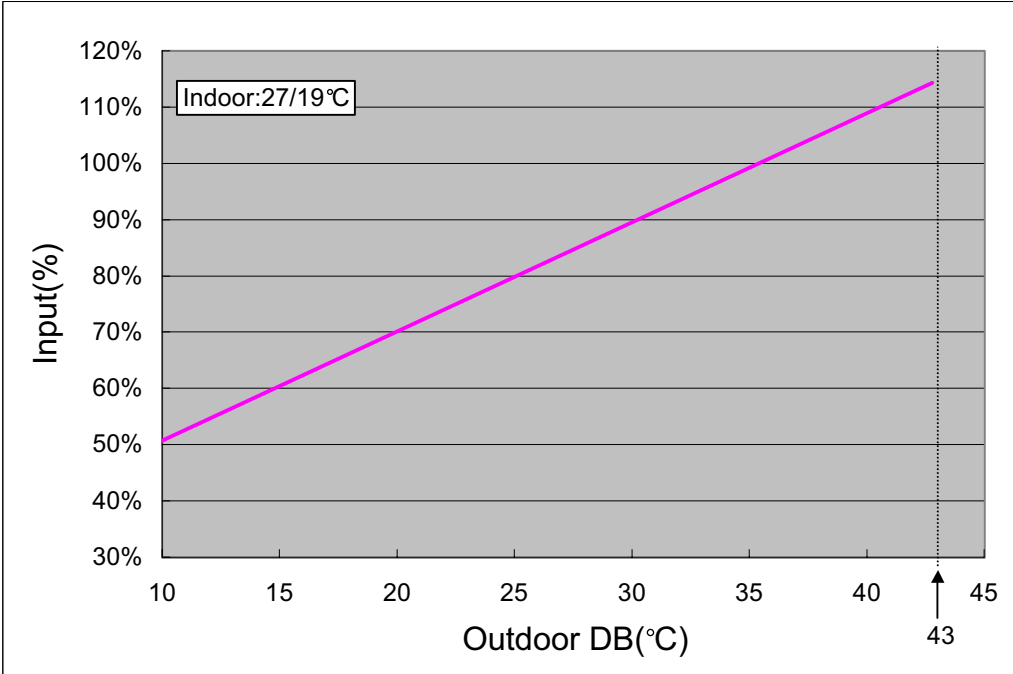

# ASYA12LCC Capacity/Input data

(1/2)

## Heating

### < Capacity >

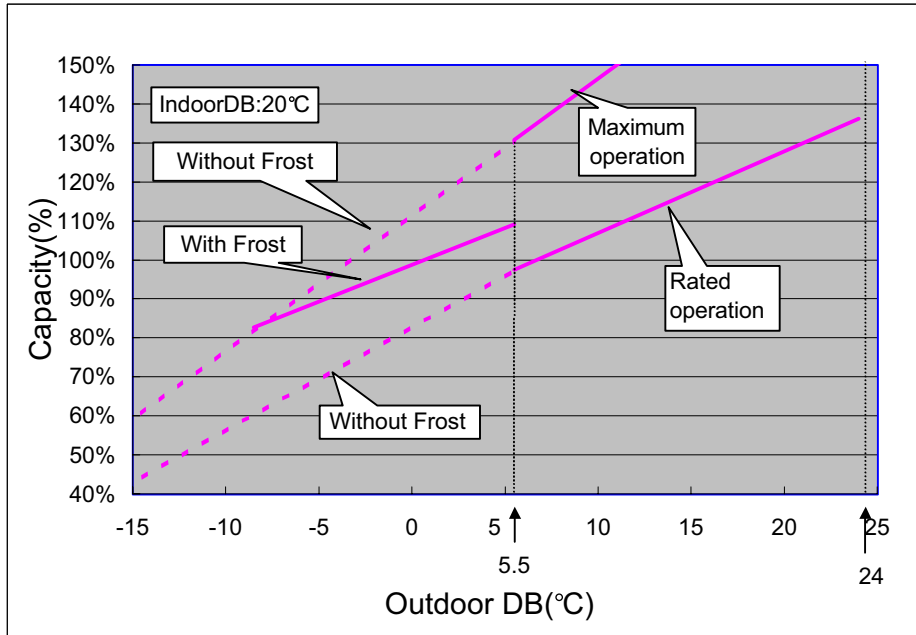

### < Input >

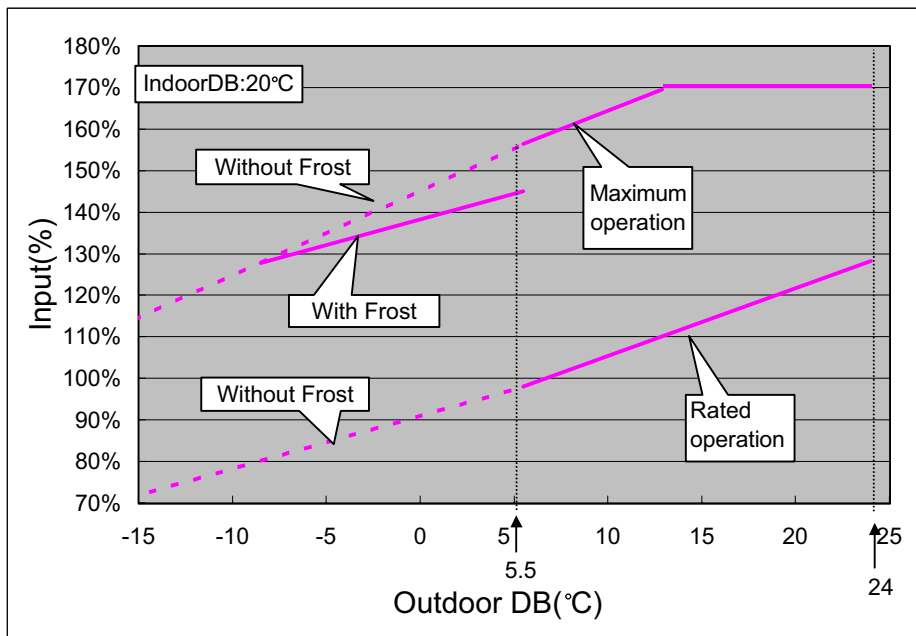

\*Defrosting operation is performed when temperature is less than 5.5 degrees C.

Frost appears on an outdoor unit heat exchanger at 5.5 or less degrees C.

\*Solid line: Integral capacity/Input containing the defrosting cycle.

\*Dotted line: Capacity/Input which does not contain the defrosting cycle.

## Cooling

### < Capacity >

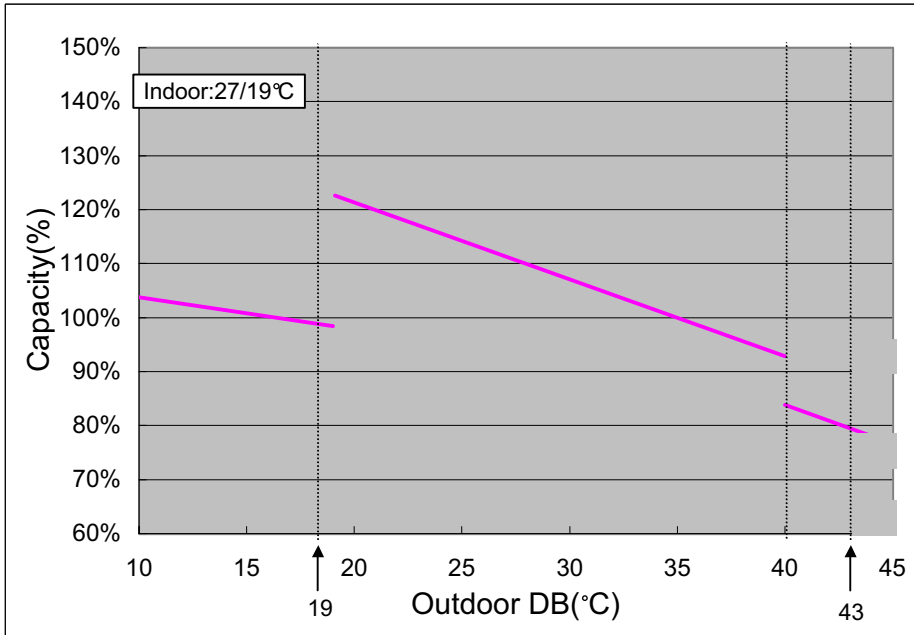

### < Input >

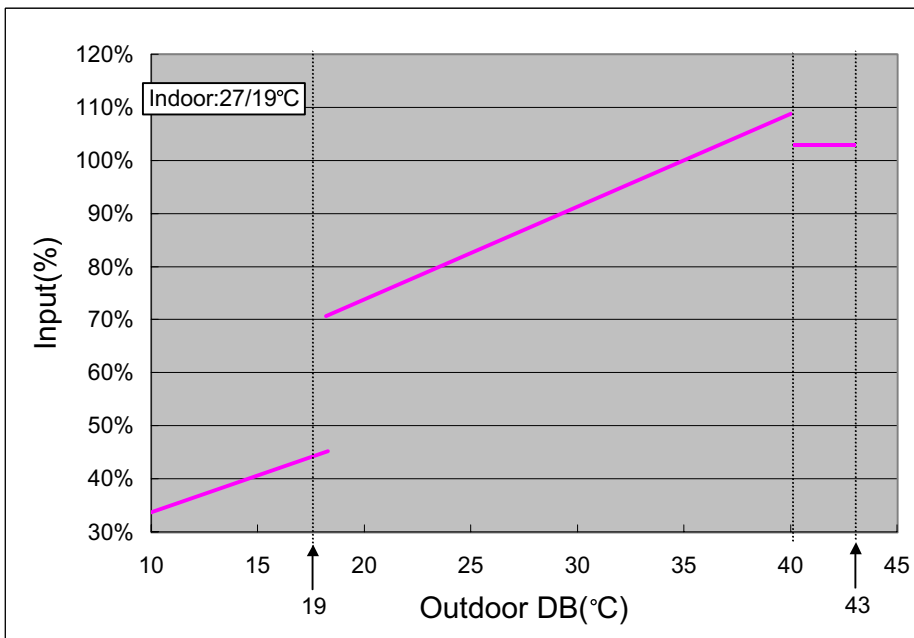

\*Both capacity and input decrease when temperature is 19 or less degrees C, for compressor frequency restrictions operate.

\*Both capacity and input decrease when temperature is 43 or more degrees C, as compressor speed is decreased due to current release protection.



# ASYA18LCC Capacity/Input data

(1/2)

## Heating

### < Capacity >

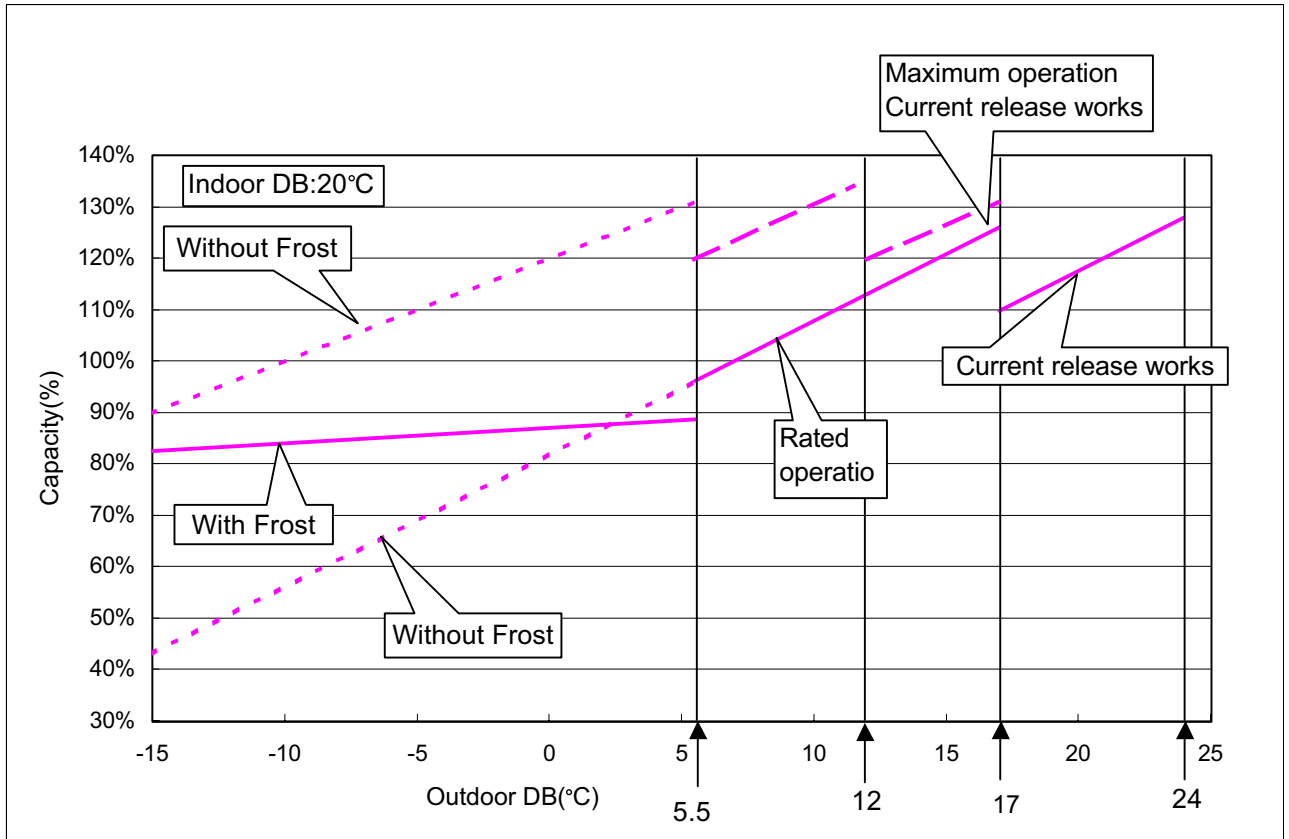

### < Input >

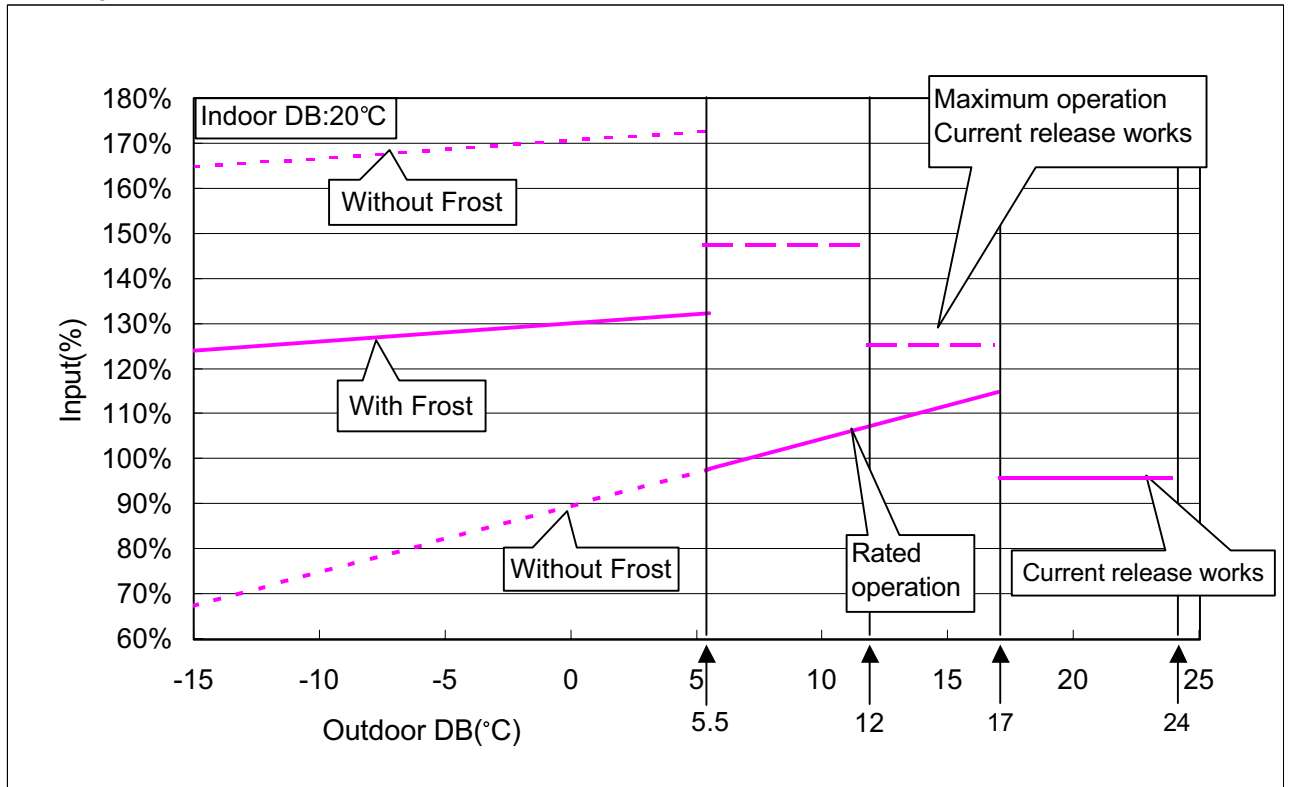

\*Defrosting operation is performed when temperature is less than 5.5 degrees C.

Frost appears on an outdoor unit heat exchanger at 5.5 or less degrees C.

\*Solid line: Integral capacity/Input containing the defrosting cycle.

\*Dotted line: Capacity/Input which does not contain the defrosting cycle.

### Cooling <Capacity>

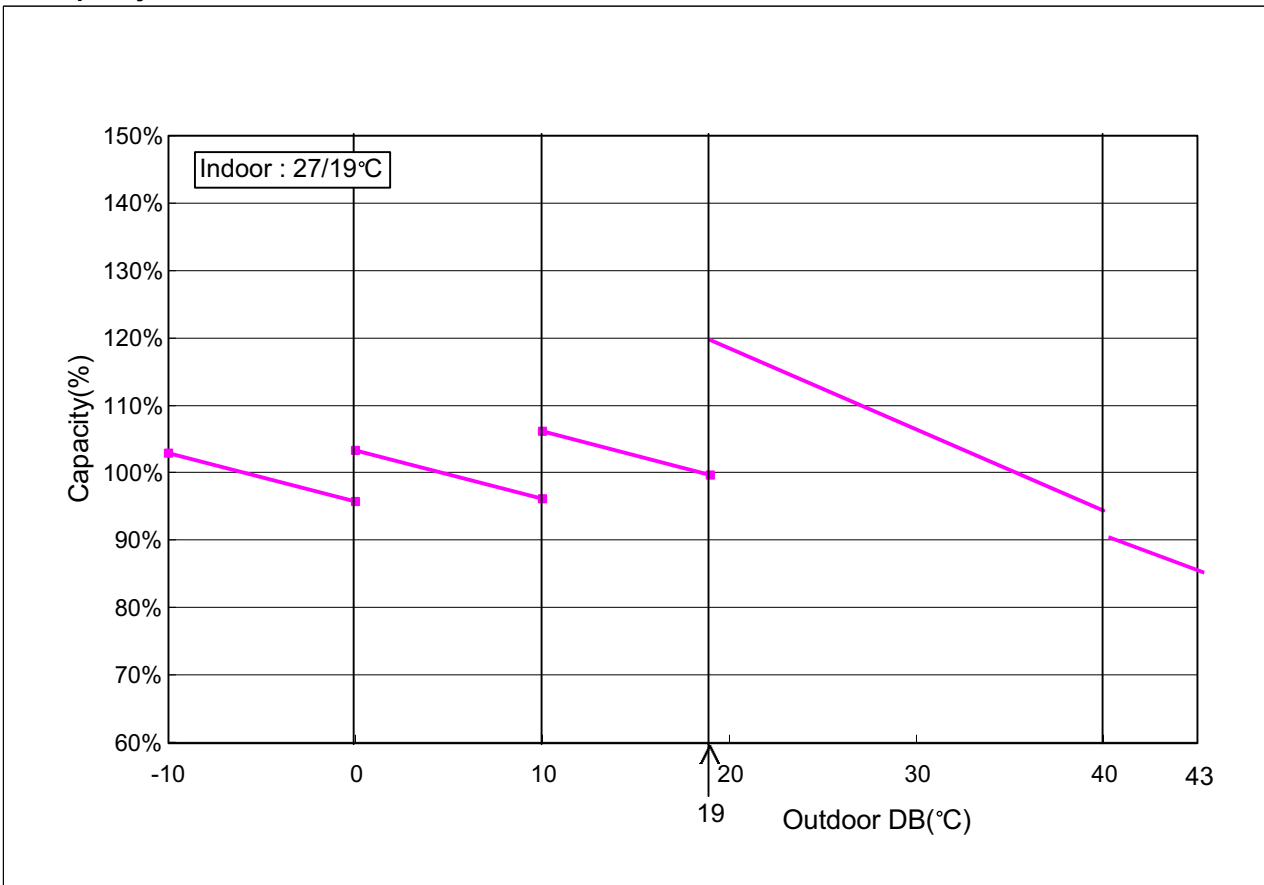

### < Input >

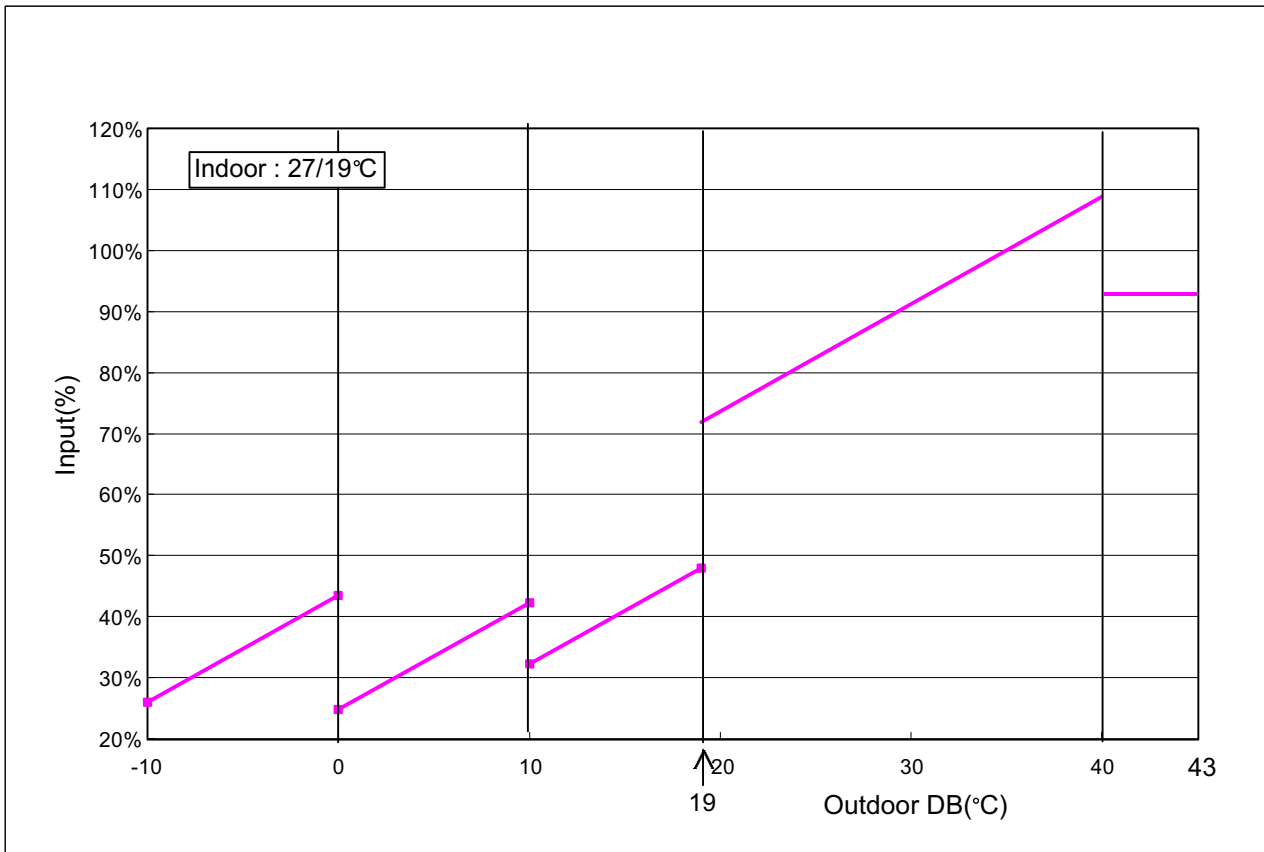

\*Both capacity and input decrease when temperature is 19 or less degrees C, for compressor frequency restrictions operate.

\*Both capacity and input decrease when temperature is 40 or more degrees C, as compressor speed is decreased due to current release protection.

\*Both capacity and input change largely when temperature is 10 or less degrees C, as outdoor fan speed is decreased due to low ambient temperature cooling control.

\*Both capacity and input change more largely at less than 0 degrees C of ambient temperature as outdoor fan speed is decreased further.

## Heating

### < Capacity >

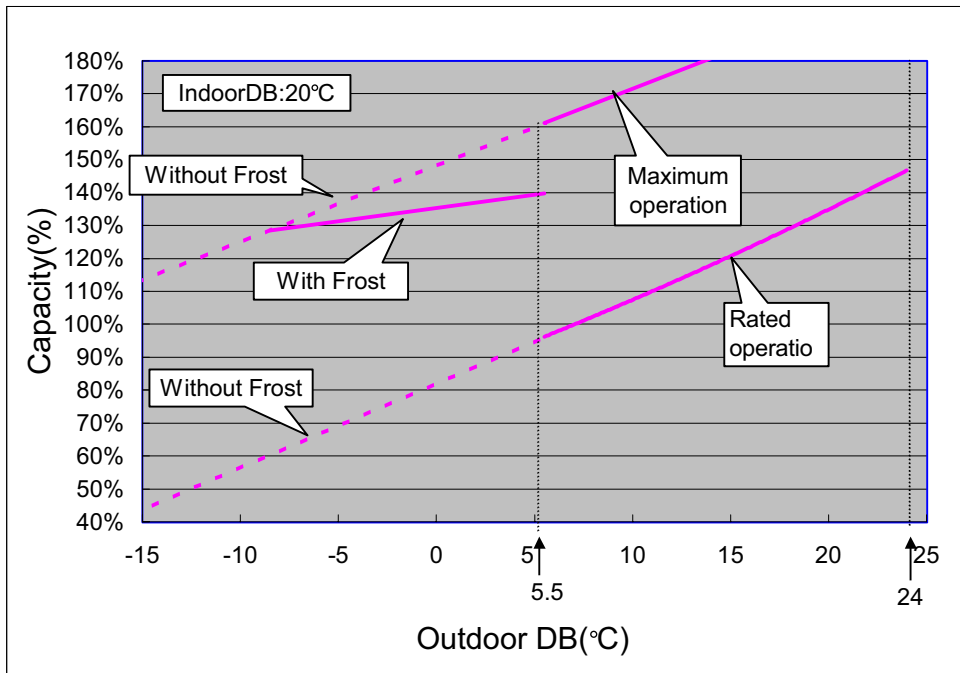

### < Input >

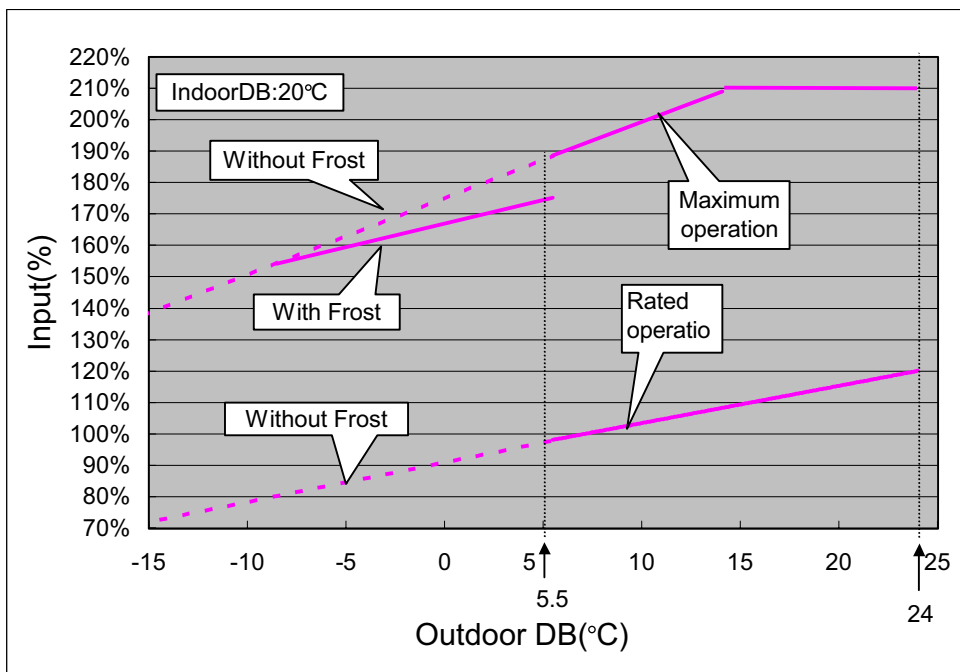

\*Defrosting operation is performed when temperature is less than 5.5 degrees C.

Frost appears on an outdoor unit heat exchanger at 5.5 or less degrees C.

\*Solid line: Integral capacity/Input containing the defrosting cycle.

\*Dotted line: Capacity/Input which does not contain the defrosting cycle.

< Capacity >

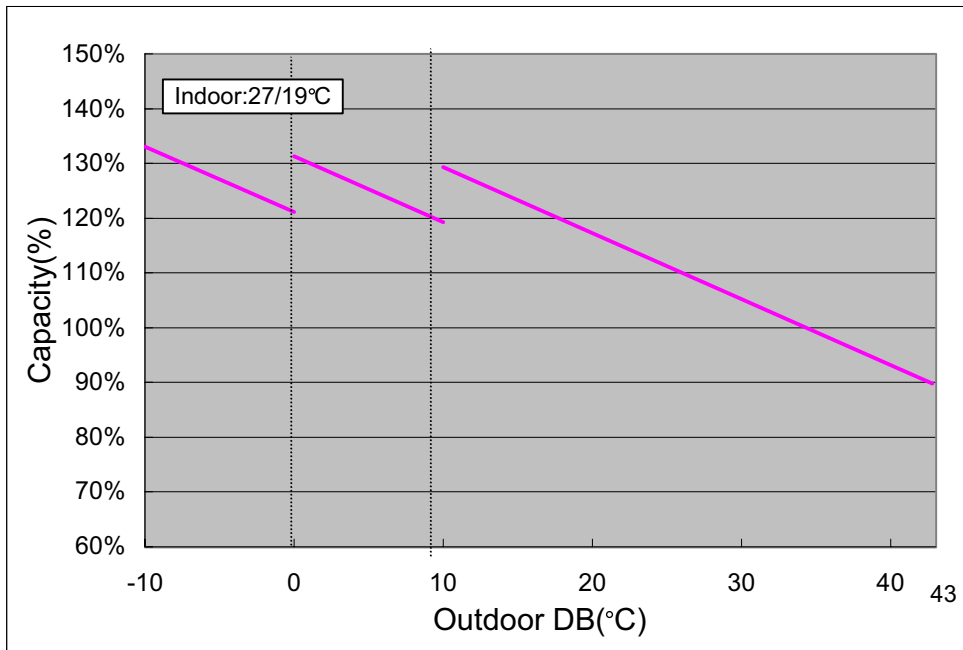

< Input >

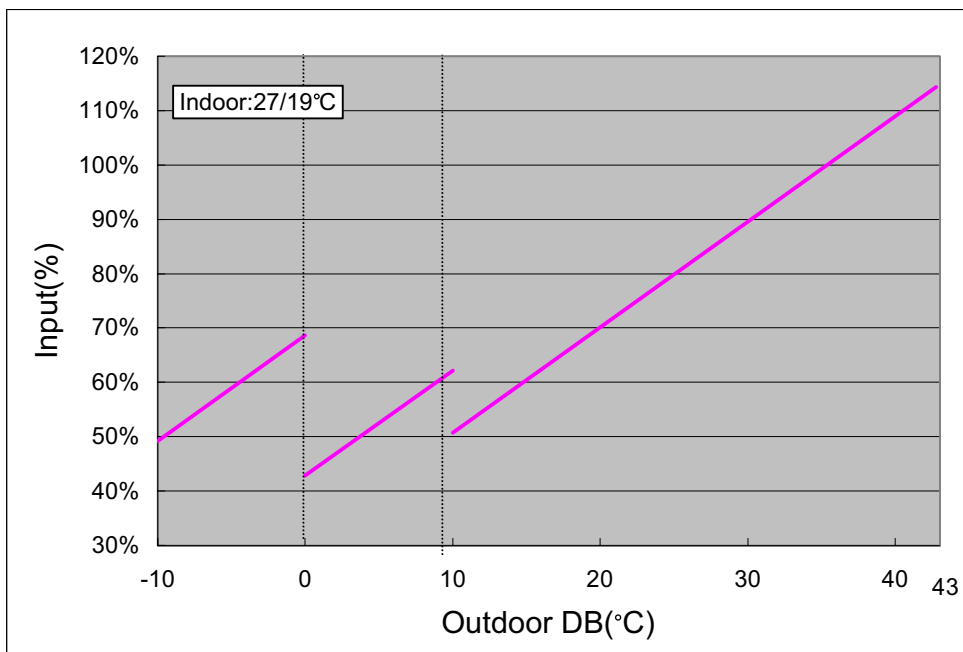

\*Both capacity and input change largely when temperature is 10 or less degrees C, as outdoor fan speed is decreased due to low ambient temperature cooling control.

\*Both capacity and input change more largely at less than 0 degrees C of ambient temperature as outdoor fan speed is decreased further.

# ASYB12LDC Capacity/Input data

(1/2)

## Heating

### < Capacity >

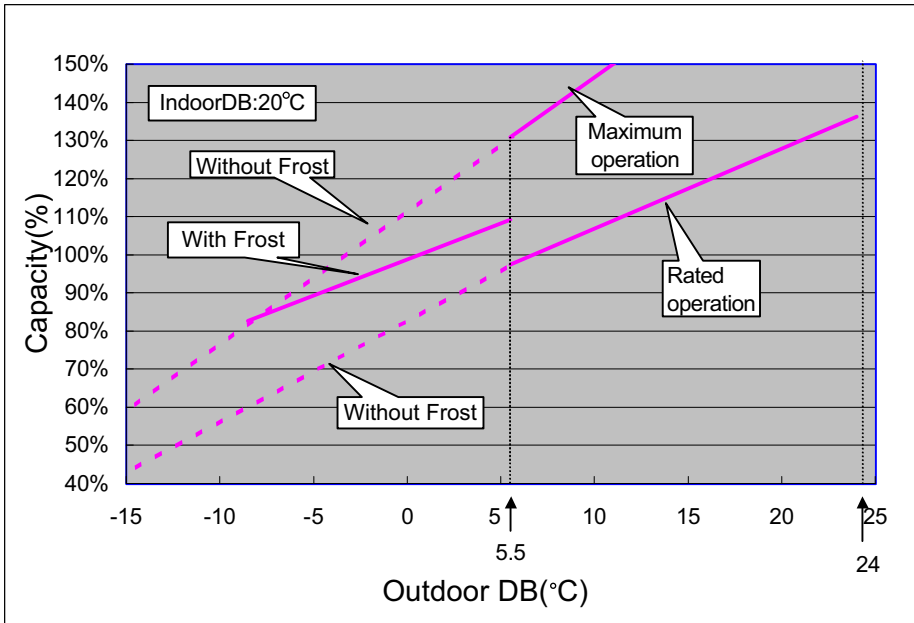

### < Input >

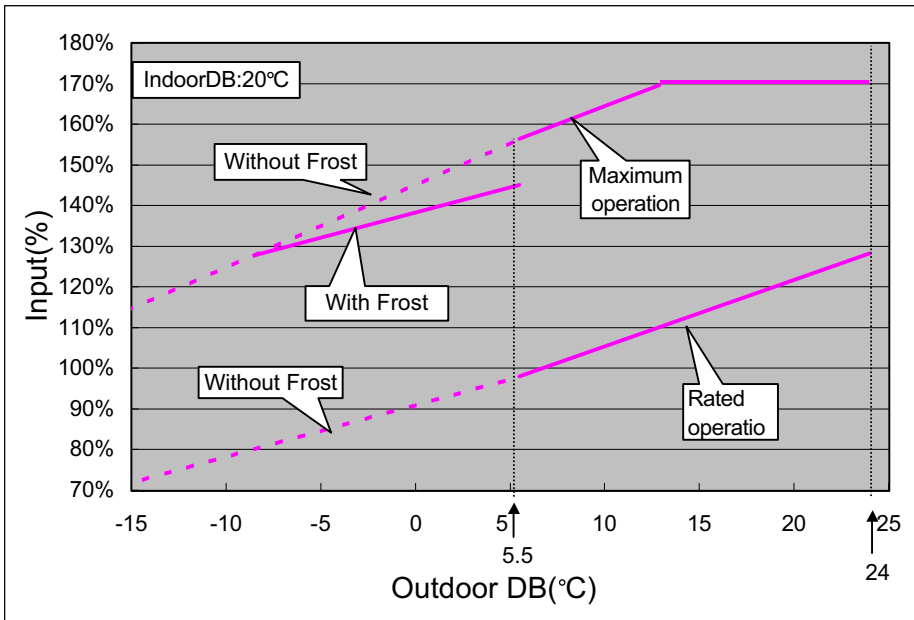

\*Defrosting operation is performed when temperature is less than 5.5 degrees C.

Frost appears on an outdoor unit heat exchanger at 5.5 or less degrees C.

\*Solid line: Integral capacity/Input containing the defrosting cycle.

\*Dotted line: Capacity/Input which does not contain the defrosting cycle.

## Cooling

### < Capacity >

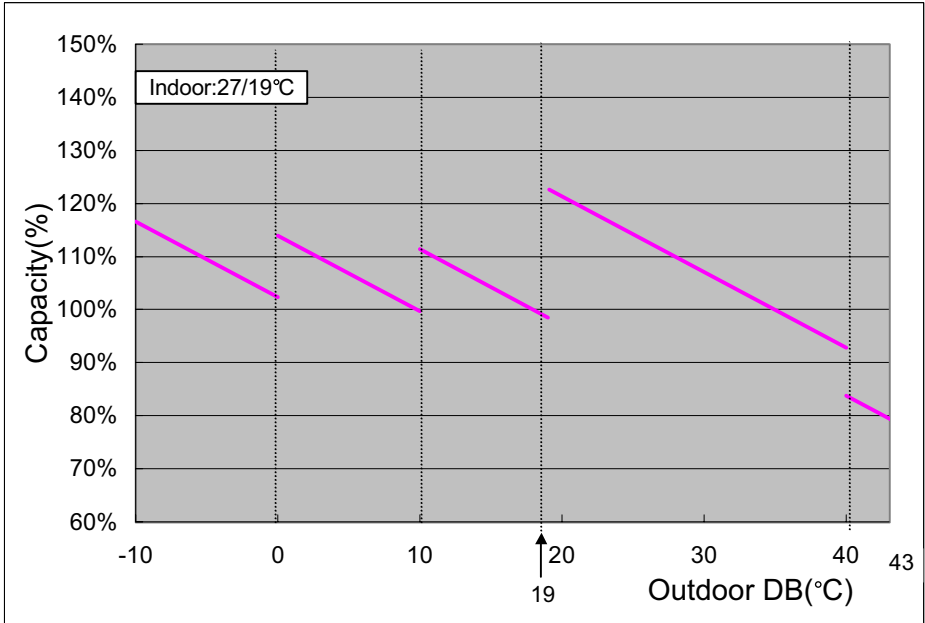

### < Input >

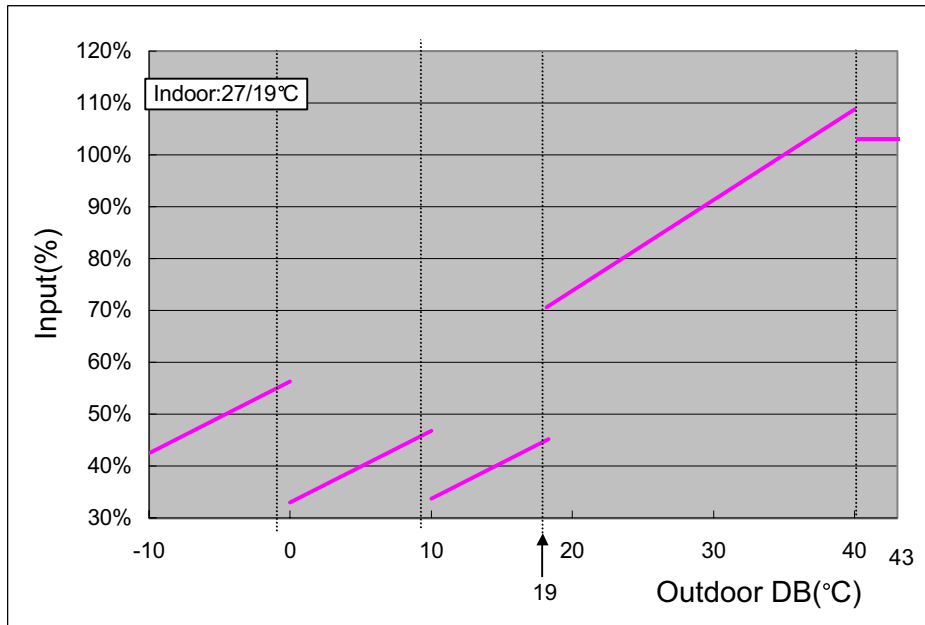

\*Both capacity and input decrease when temperature is 19 or less degrees C, for compressor frequency restrictions operate.

\*Both capacity and input decrease when temperature is 40 or more degrees C, as compressor speed is decreased due to current release protection.

Both capacity and input change largely when temperature is 10 or less degrees C, as outdoor fan speed is decreased due to low ambient temperature cooling control.

Both capacity and input change more largely at less than 0 degrees C of ambient temperature as outdoor fan speed is decreased further.

# ***WALL MOUNTED type INVERTER***

## **9 . REPLACEMENT PARTS**

# REPLACEMENT PARTS

Models : ASYA07LCC  
ASYA09LCC

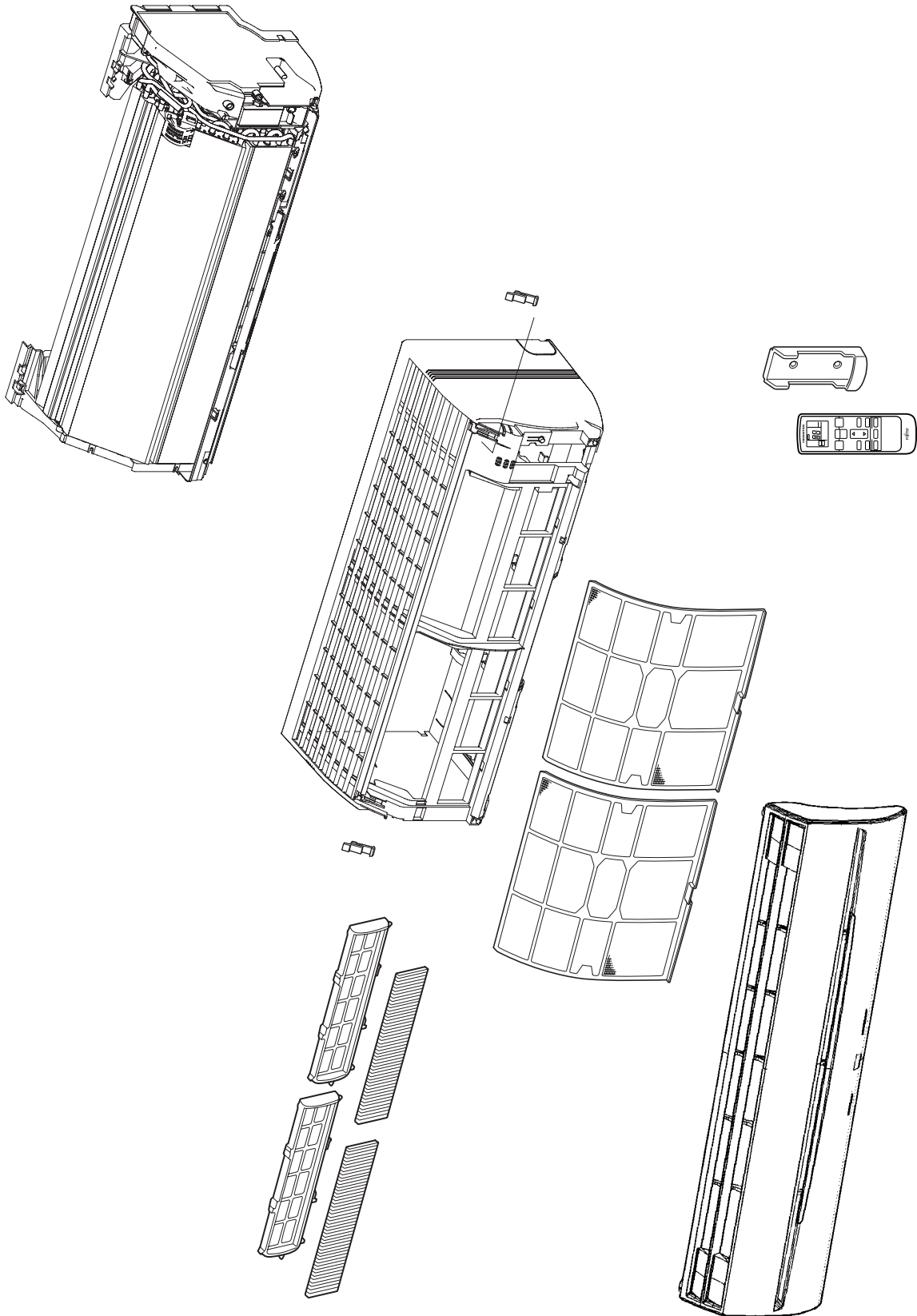



# REPLACEMENT PARTS

Models : ASYA07LCC  
ASYA09LCC

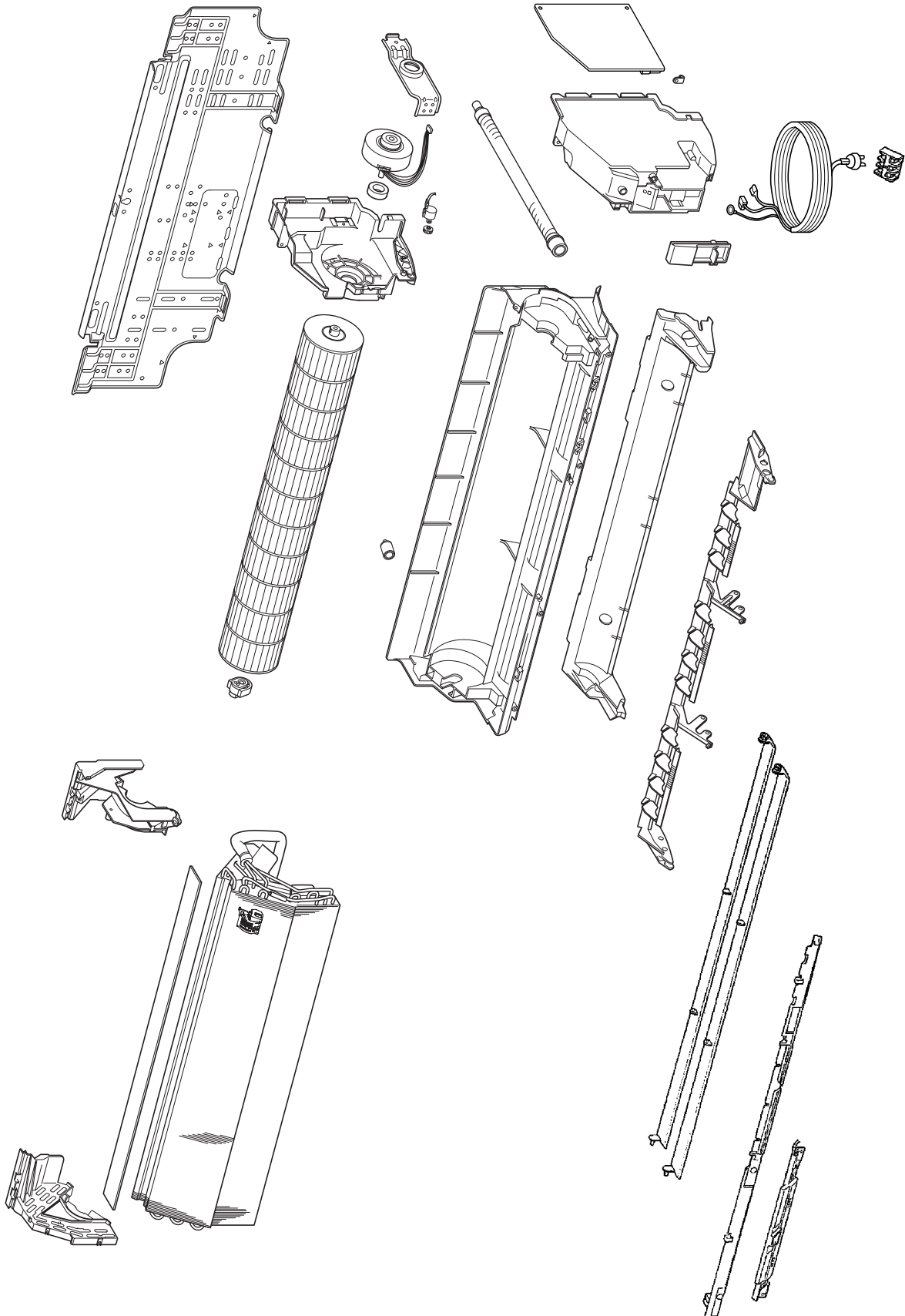

# REPLACEMENT PARTS

Models : AOYR07LCC  
AOYR09LCC

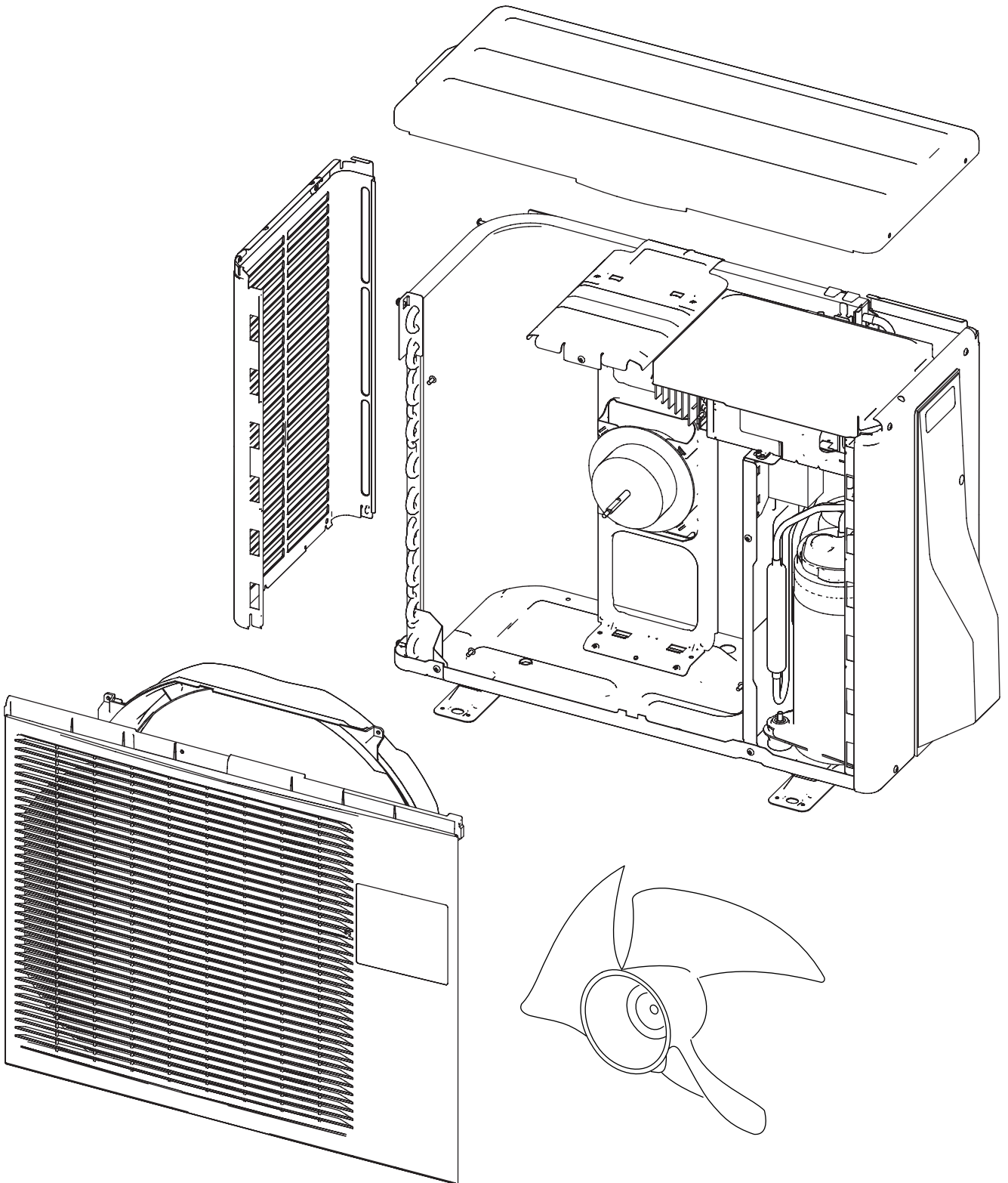

# REPLACEMENT PARTS

Models : AOYR07LCC  
AOYR09LCC

---

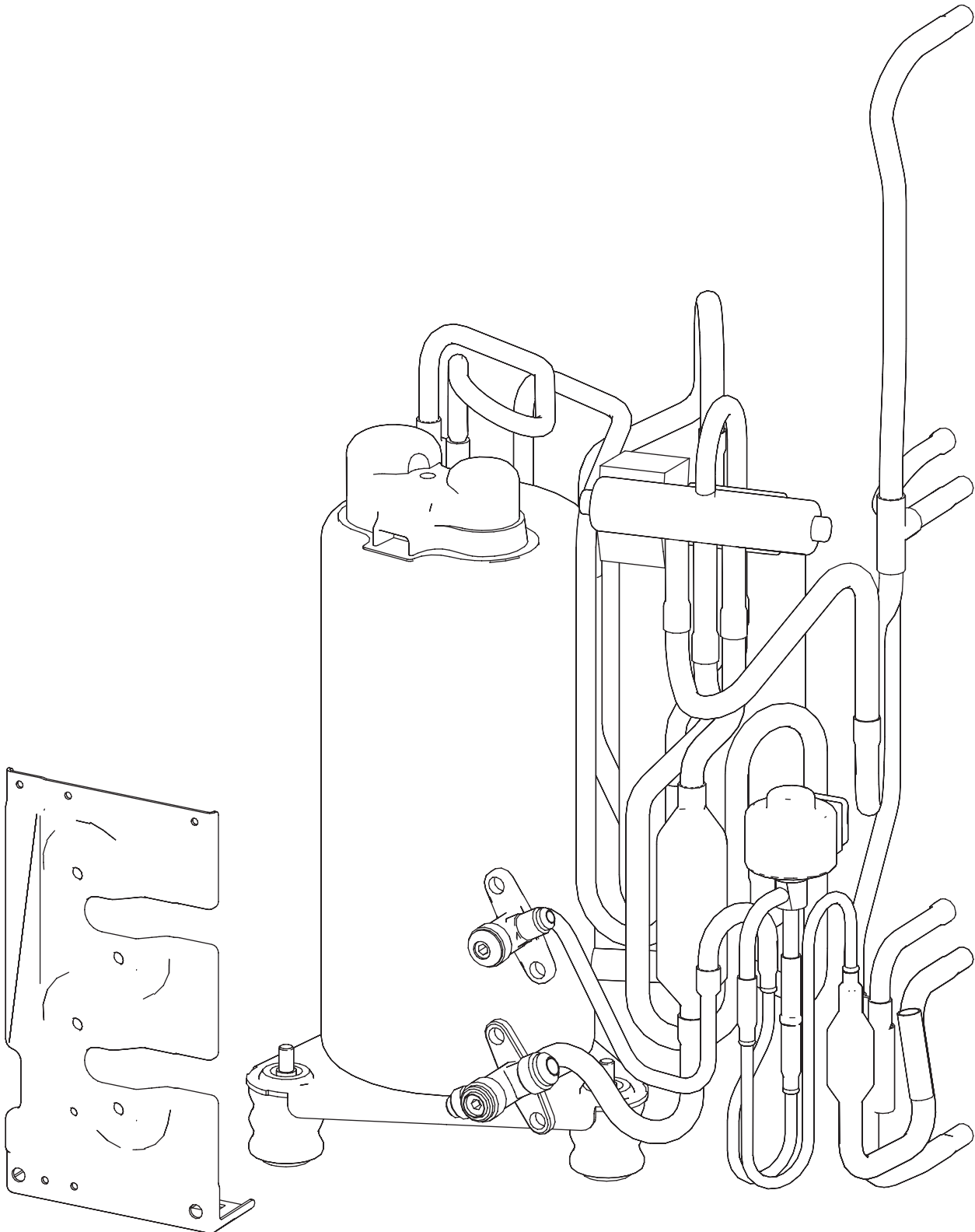

# REPLACEMENT PARTS

Models : AOYR07LCC  
AOYR09LCC

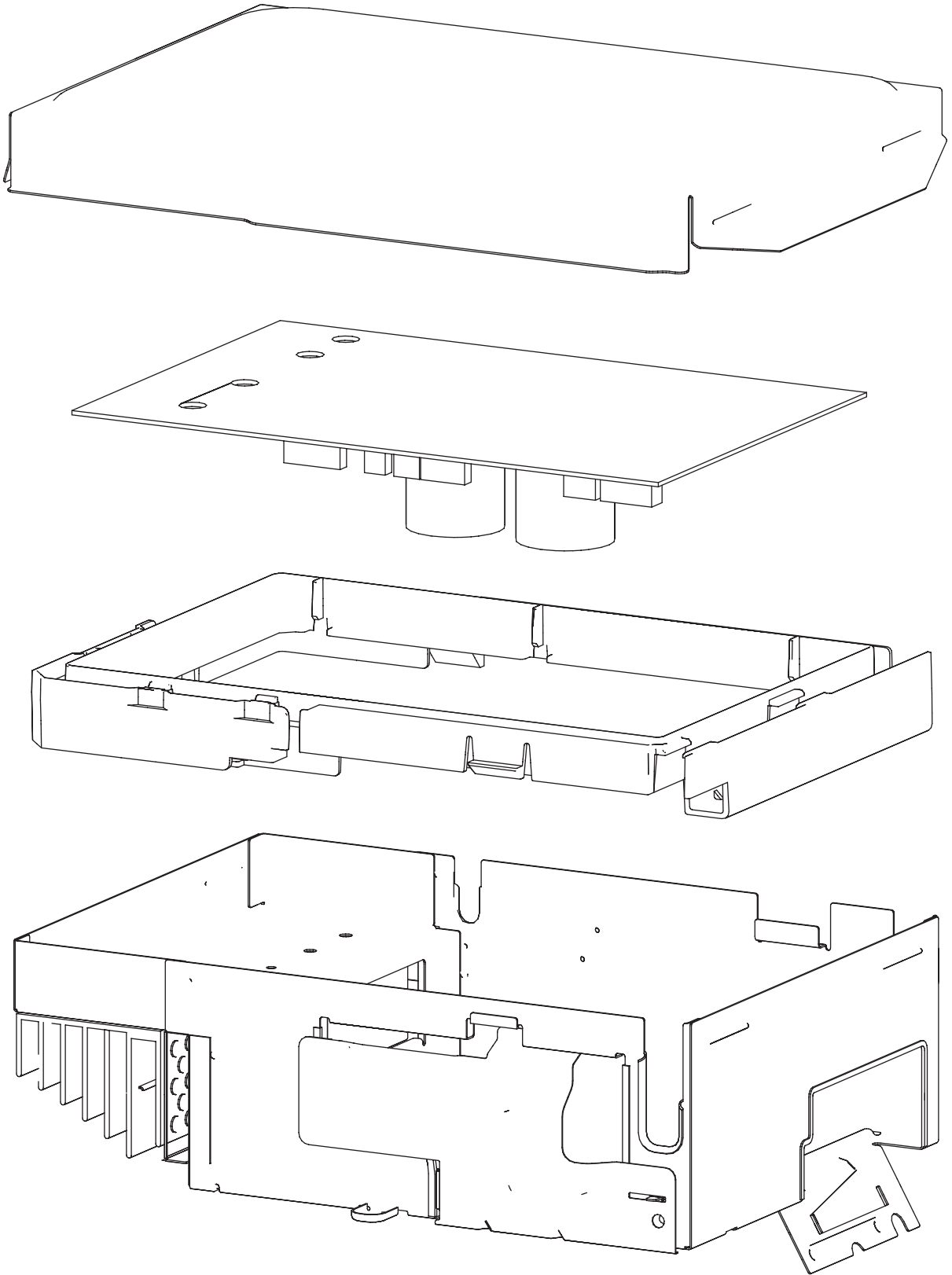

# REPLACEMENT PARTS

Models : ASYA12LCC

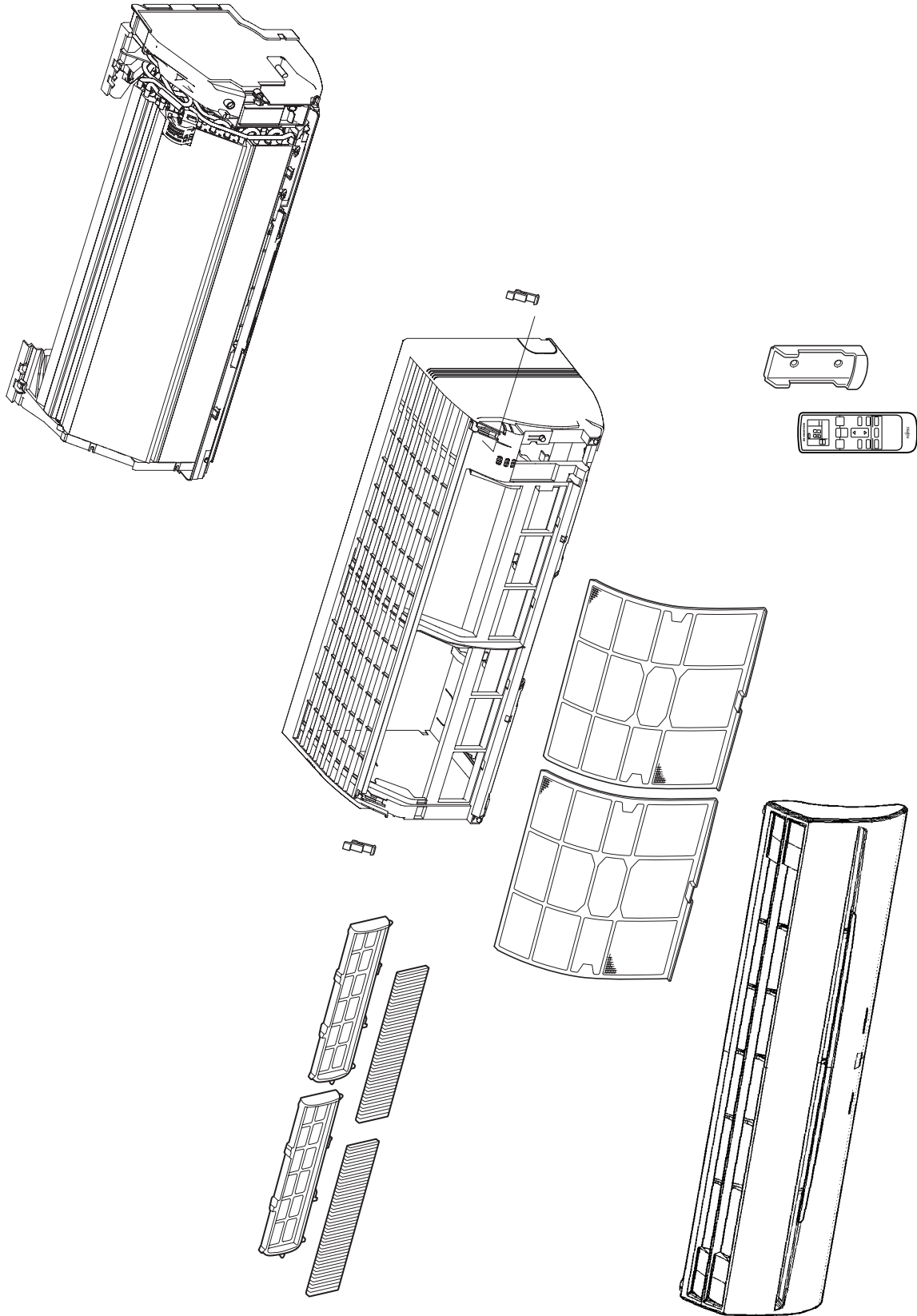

# REPLACEMENT PARTS

Models : ASYA12LCC

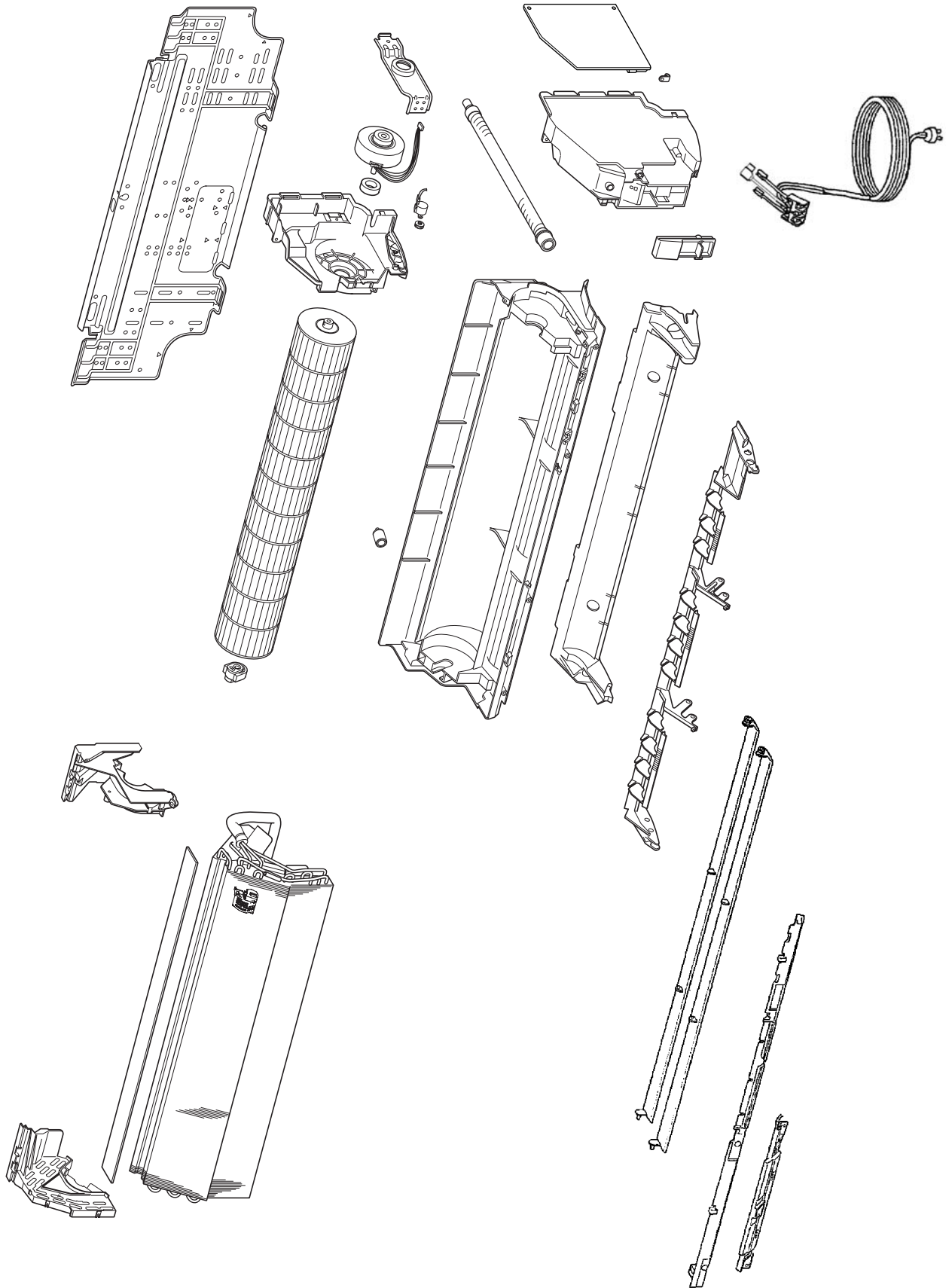

# REPLACEMENT PARTS

Models : AOYR12LCC

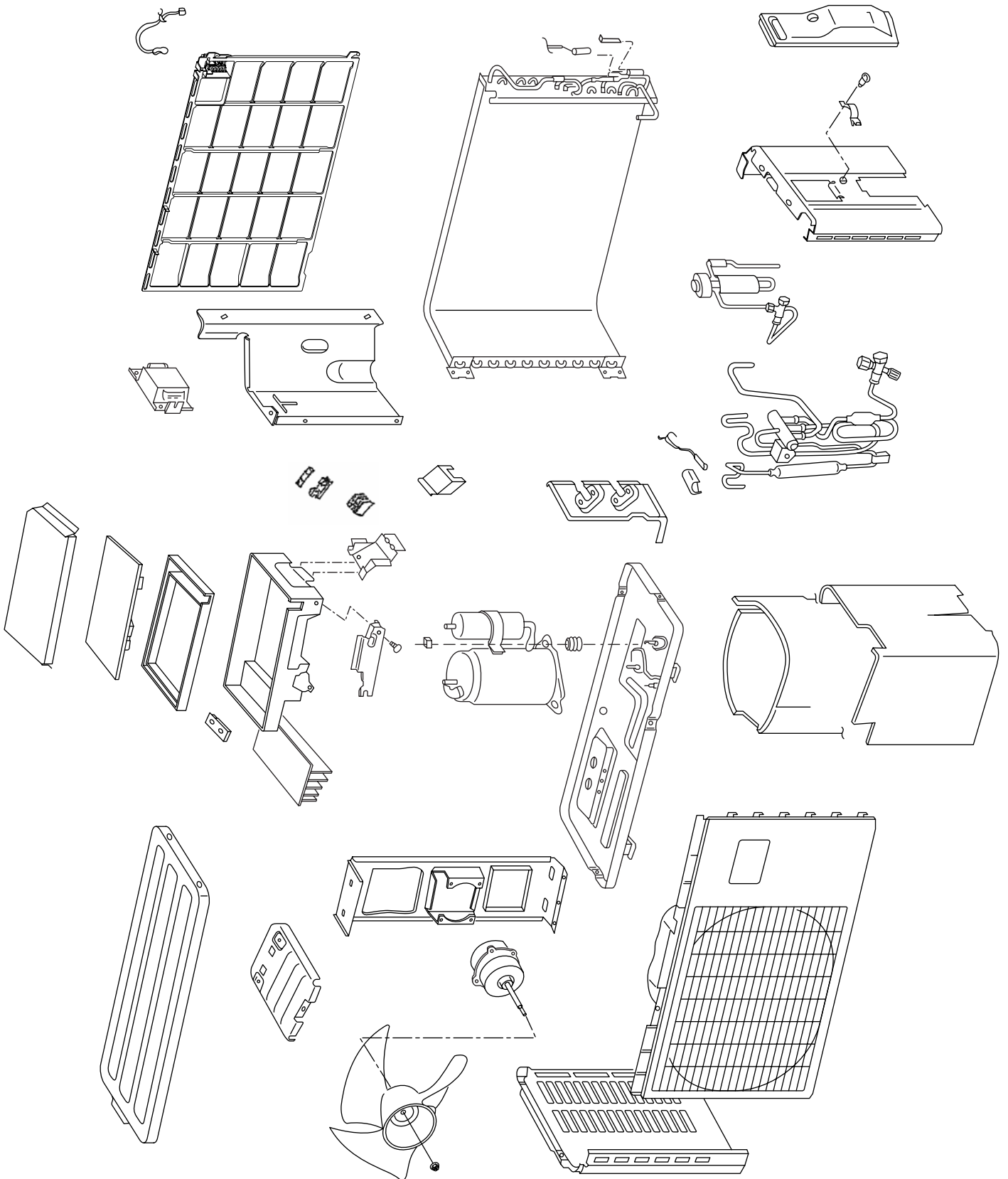

# REPLACEMENT PARTS

Models : ASYA14LCC  
ASYA18LCC

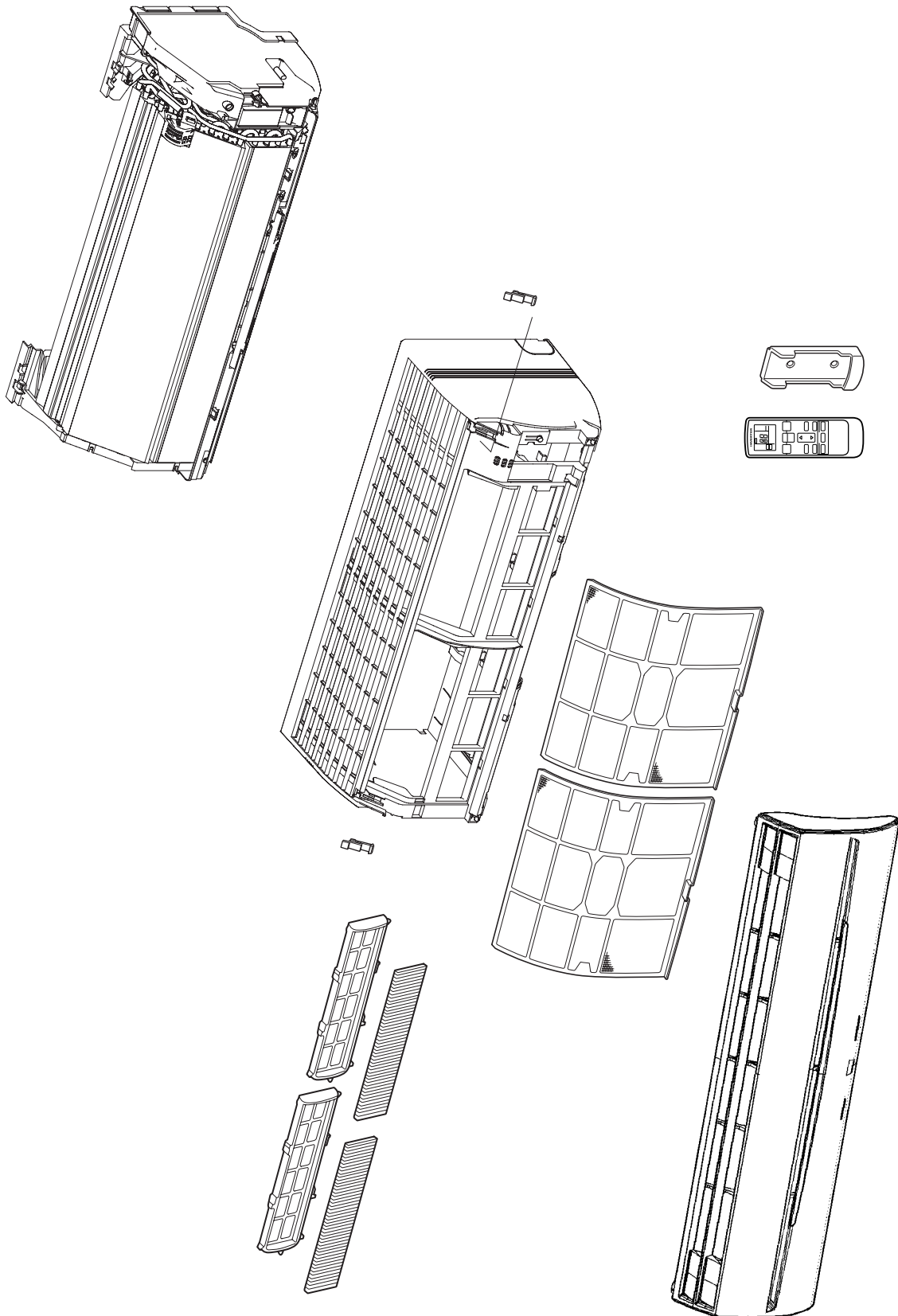



# REPLACEMENT PARTS

Models : ASYA14LCC  
ASYA18LCC

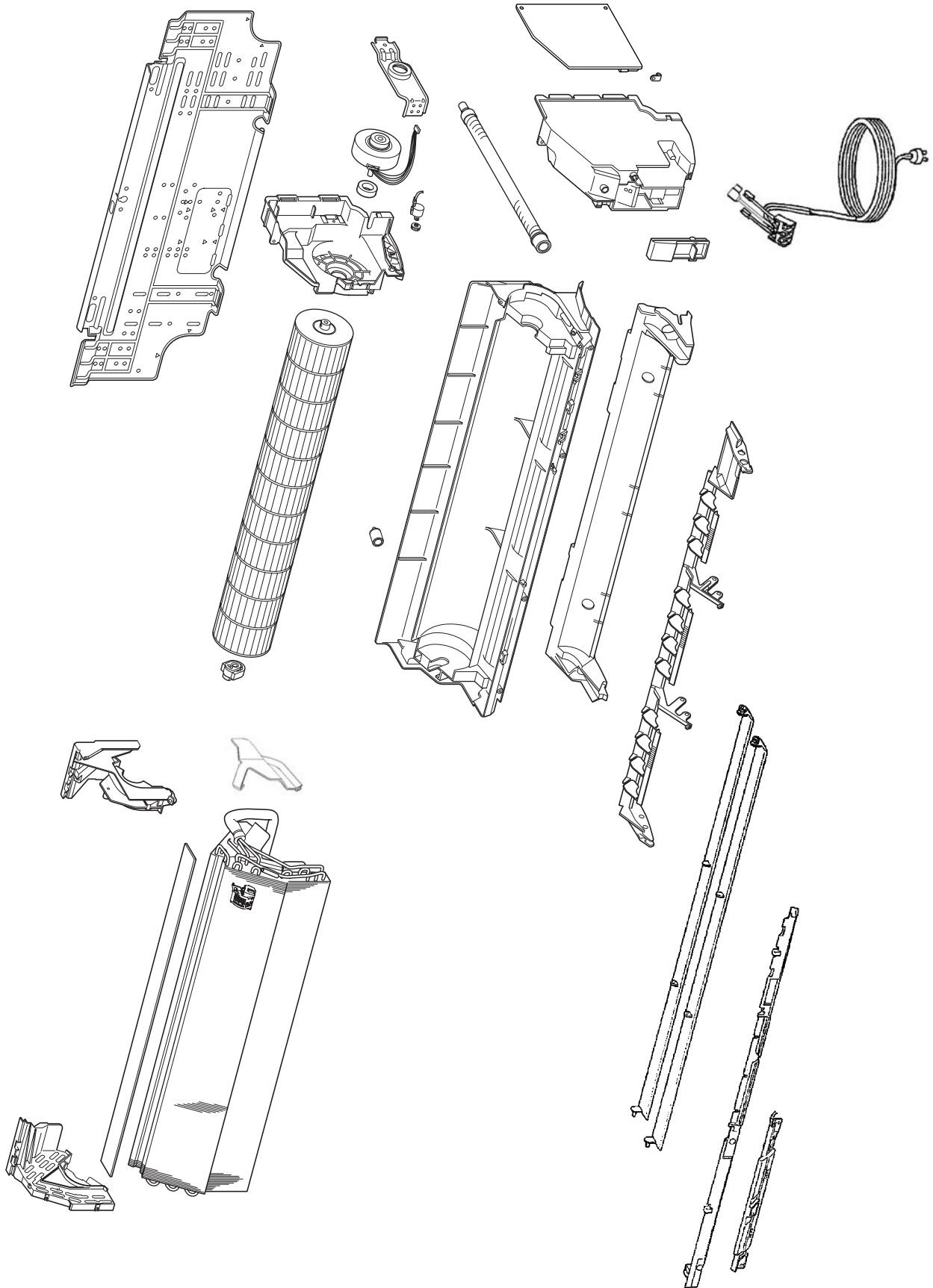

# REPLACEMENT PARTS

Models : AOYR14LCC  
AOYR18LCC

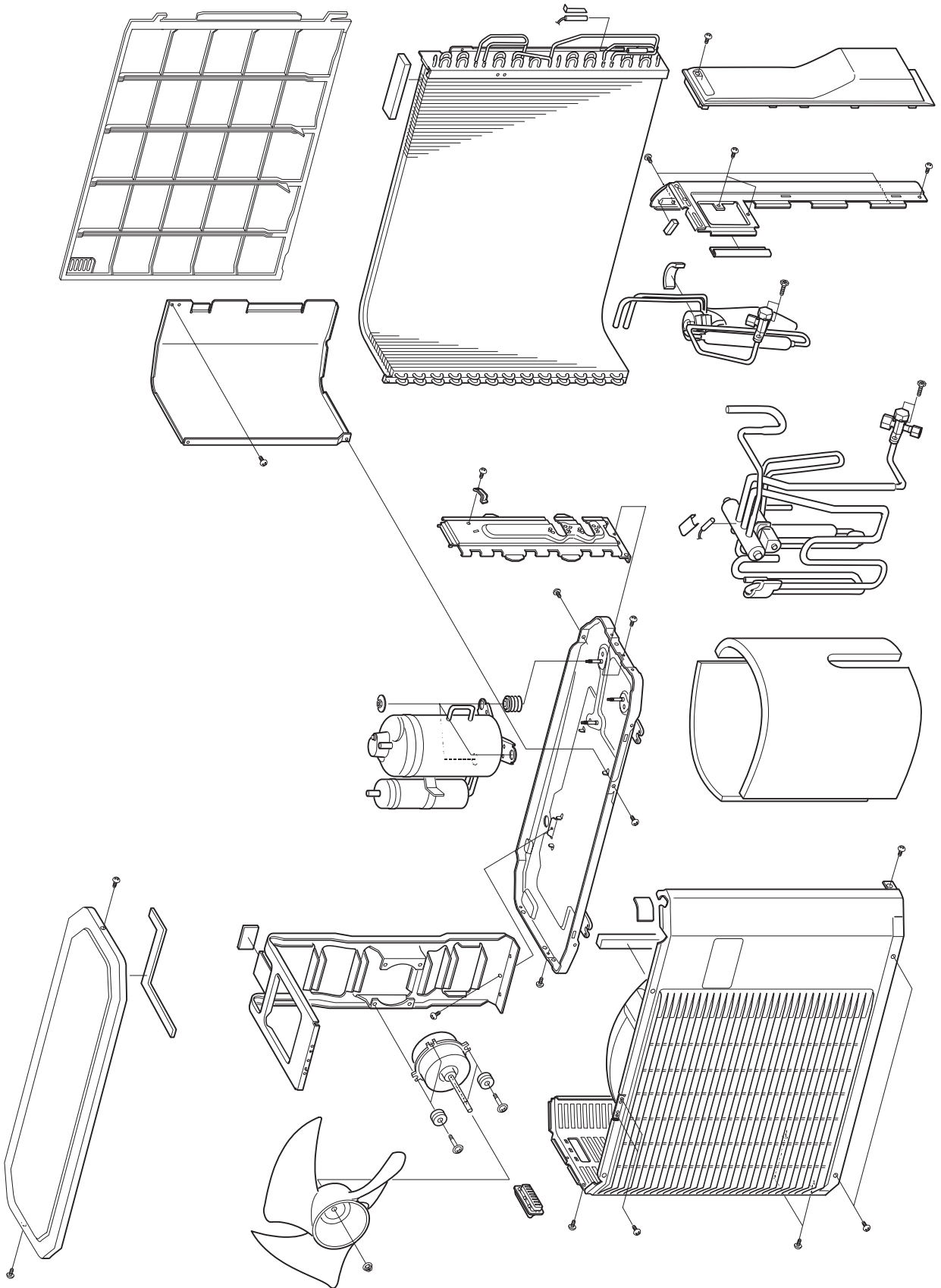

# REPLACEMENT PARTS

Models : AOYR14LCC  
AOYR18LCC

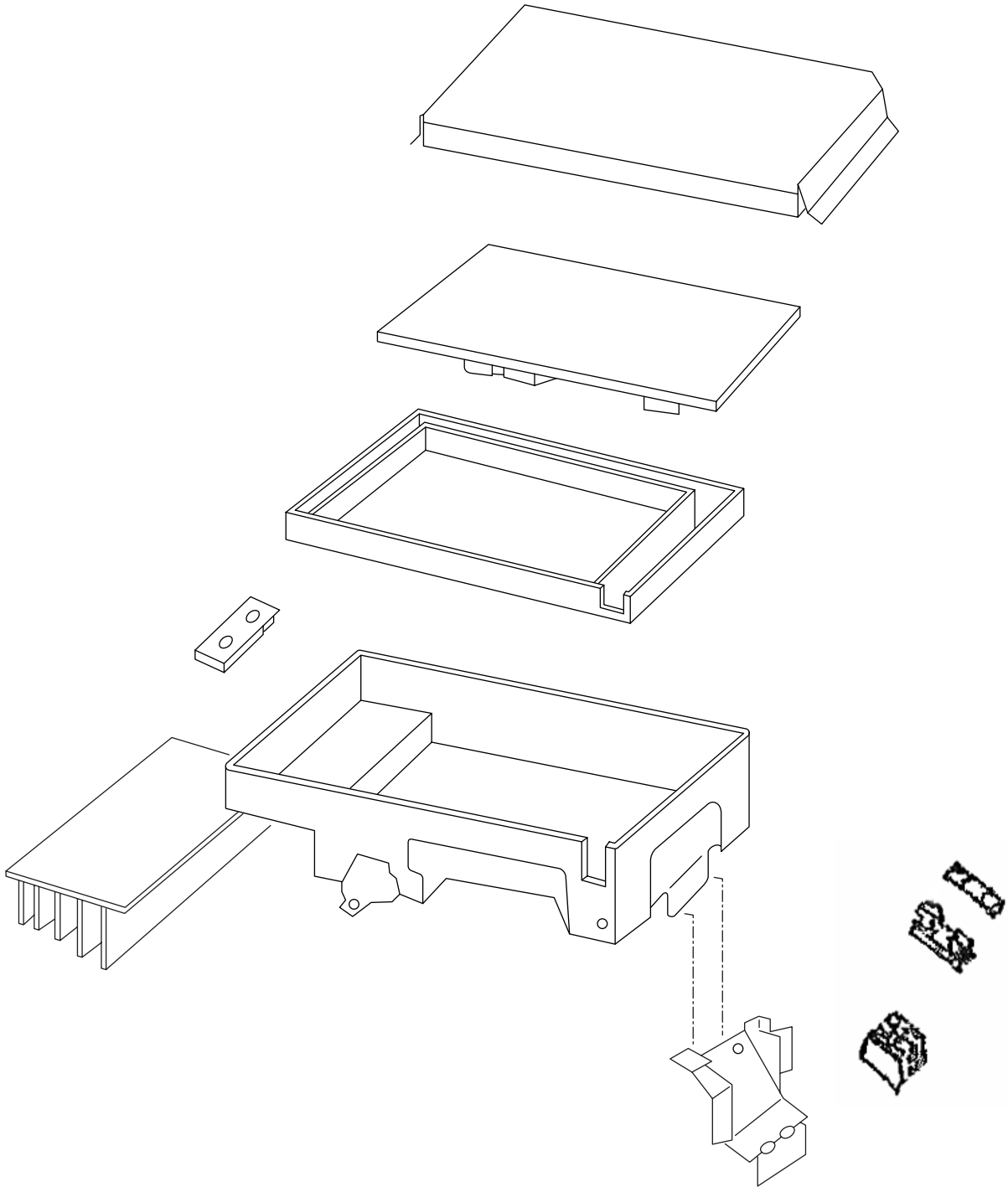

# REPLACEMENT PARTS

Models : ASYB09LDC  
ASYB12LDC

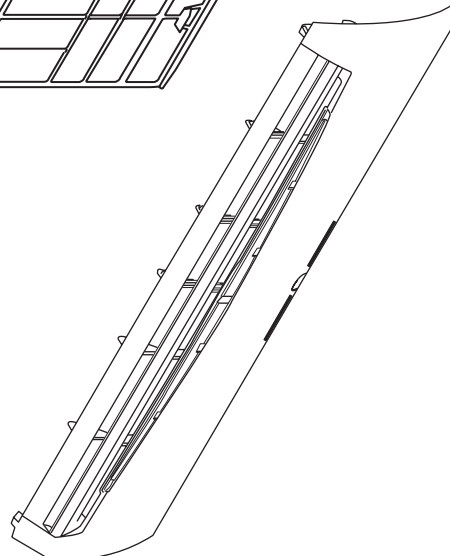
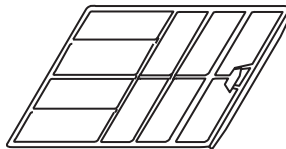
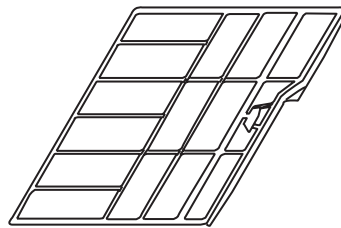
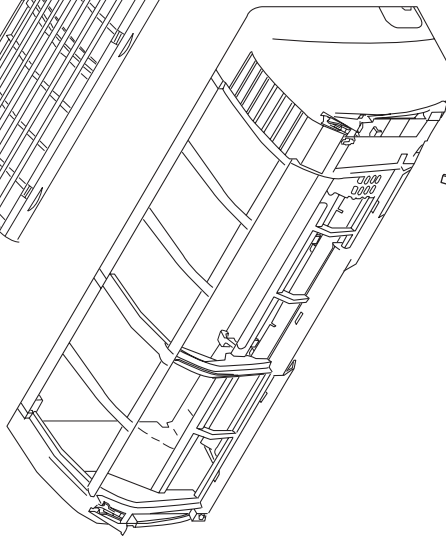
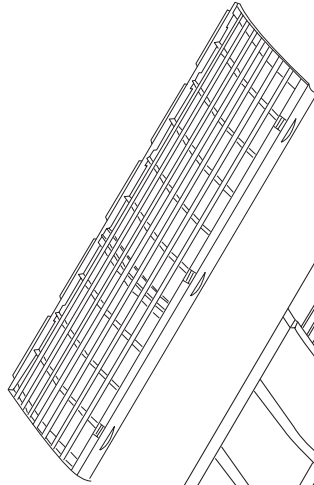
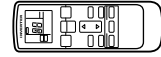
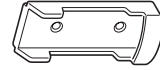
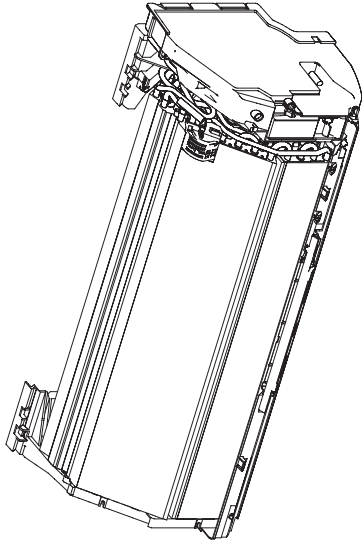

# REPLACEMENT PARTS

Models : ASYB09LDC  
ASYB12LDC

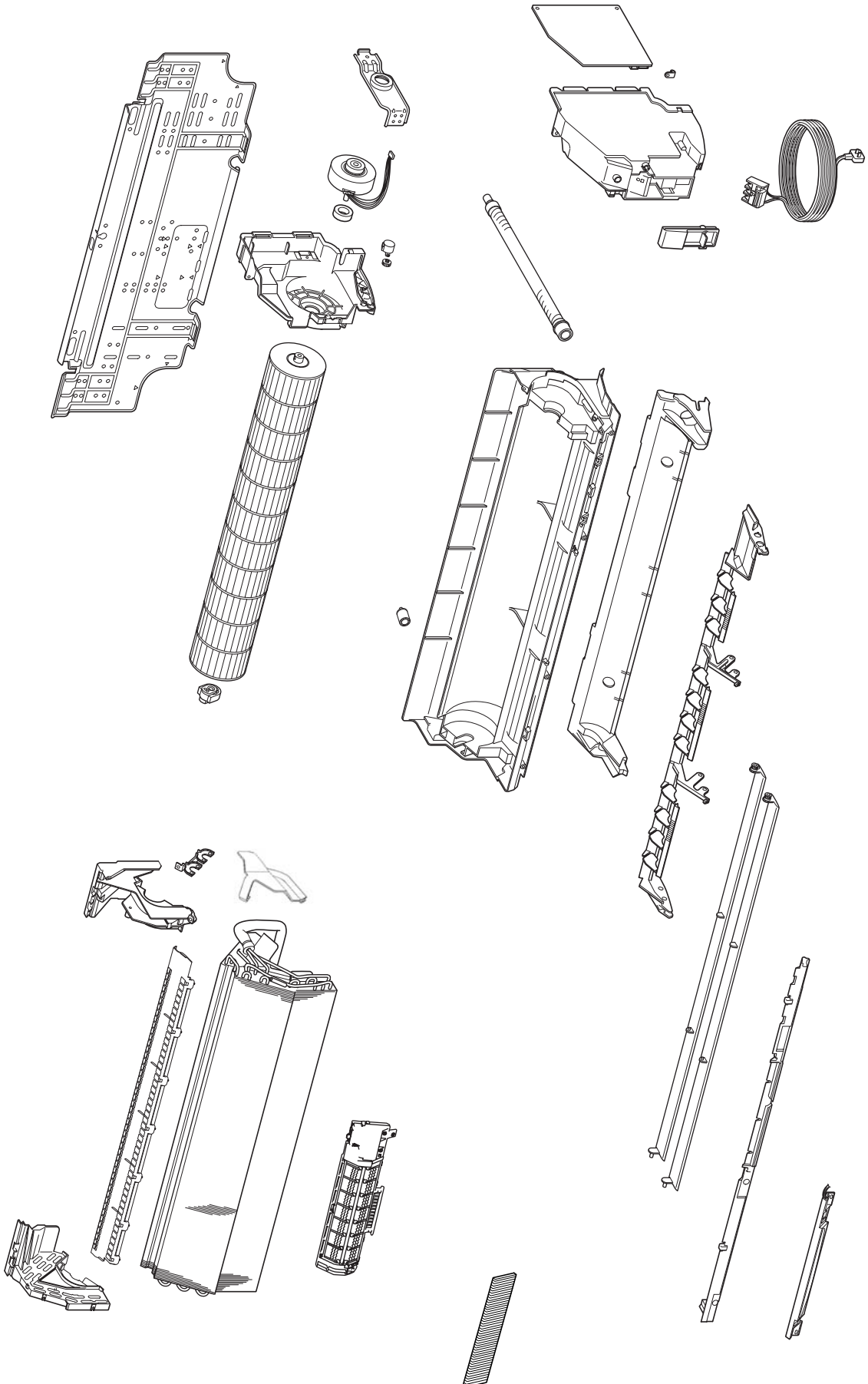

# REPLACEMENT PARTS

Models : AOYS09LDC  
AOYS12LDC

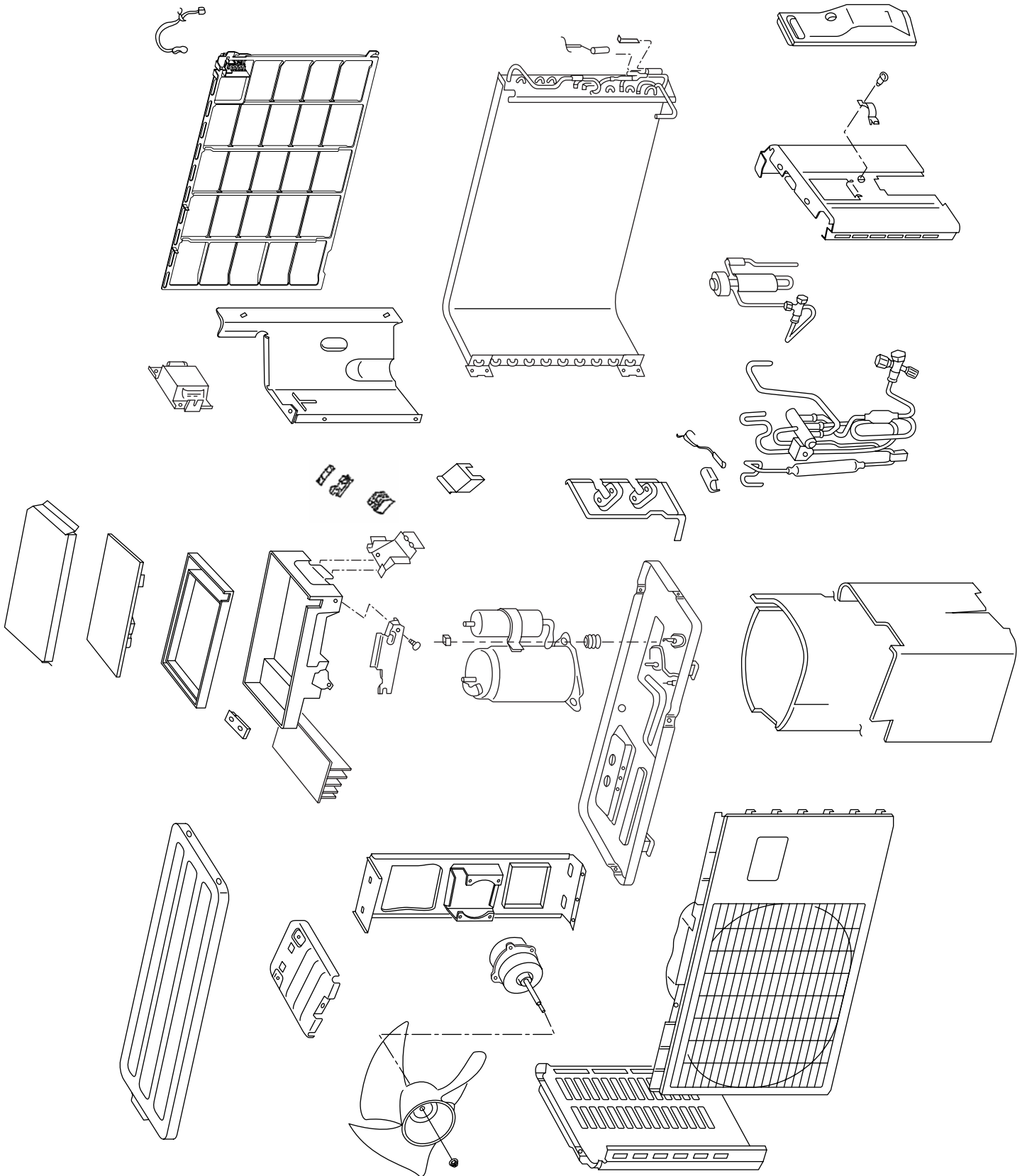

# REPLACEMENT PARTS

MODEL:AOYR07/09LCC  
PROCESS Wiring lead wire

## REGULATIONS

Like a rough sketch, wire COMP lead wire and REACTOR lead wire.

Like a rough sketch, pass each lead wire to guide for the lead wire of HOLDER(PWB).

Each lead wire are wired without sag and twist ,and must be in the ditch of HOLDER(PWB).

Like a rough sketch, Assemble the WIRE.

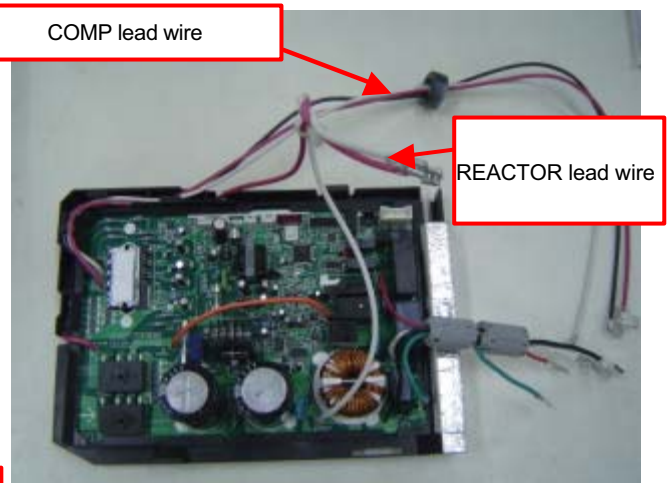
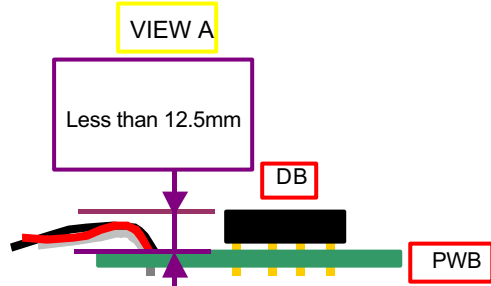

Through the Comp. lead upper side of the reactor lead.

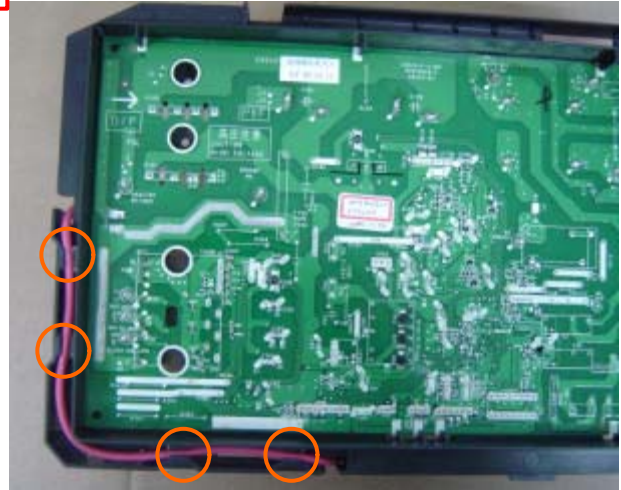
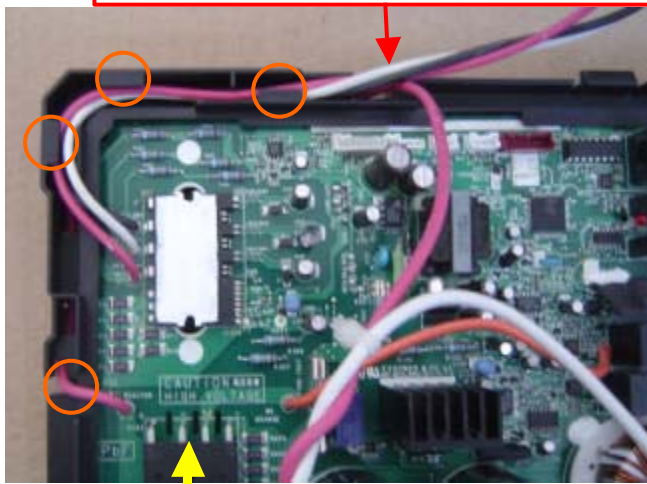

# REPLACEMENT PARTS

Model:AOYR07/09LCC

Process Connection of leads to inverter assy

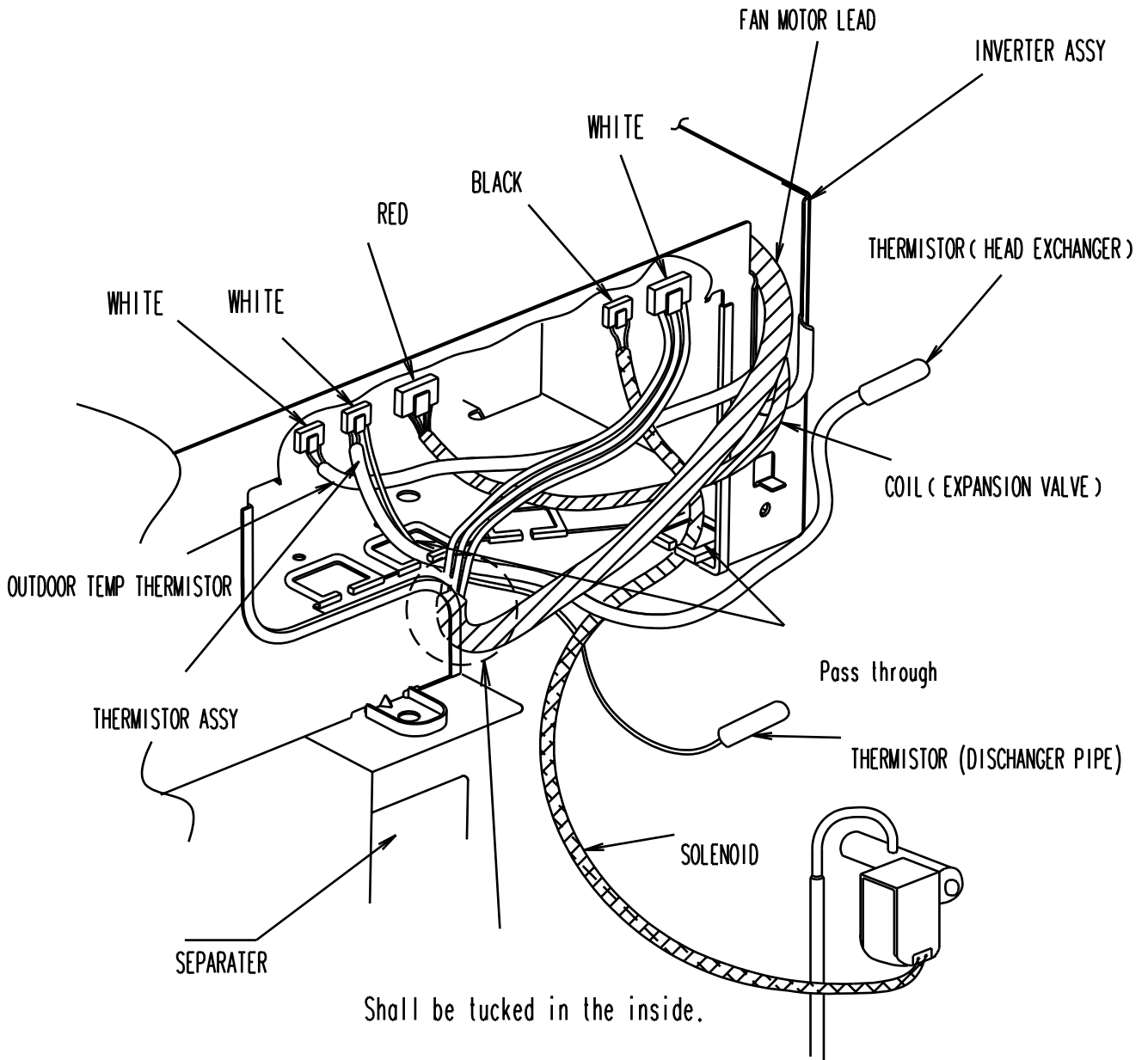



# REPLACEMENT PARTS

Model:AOYR07/09LCC

Process Shaping of leads to inverter assy

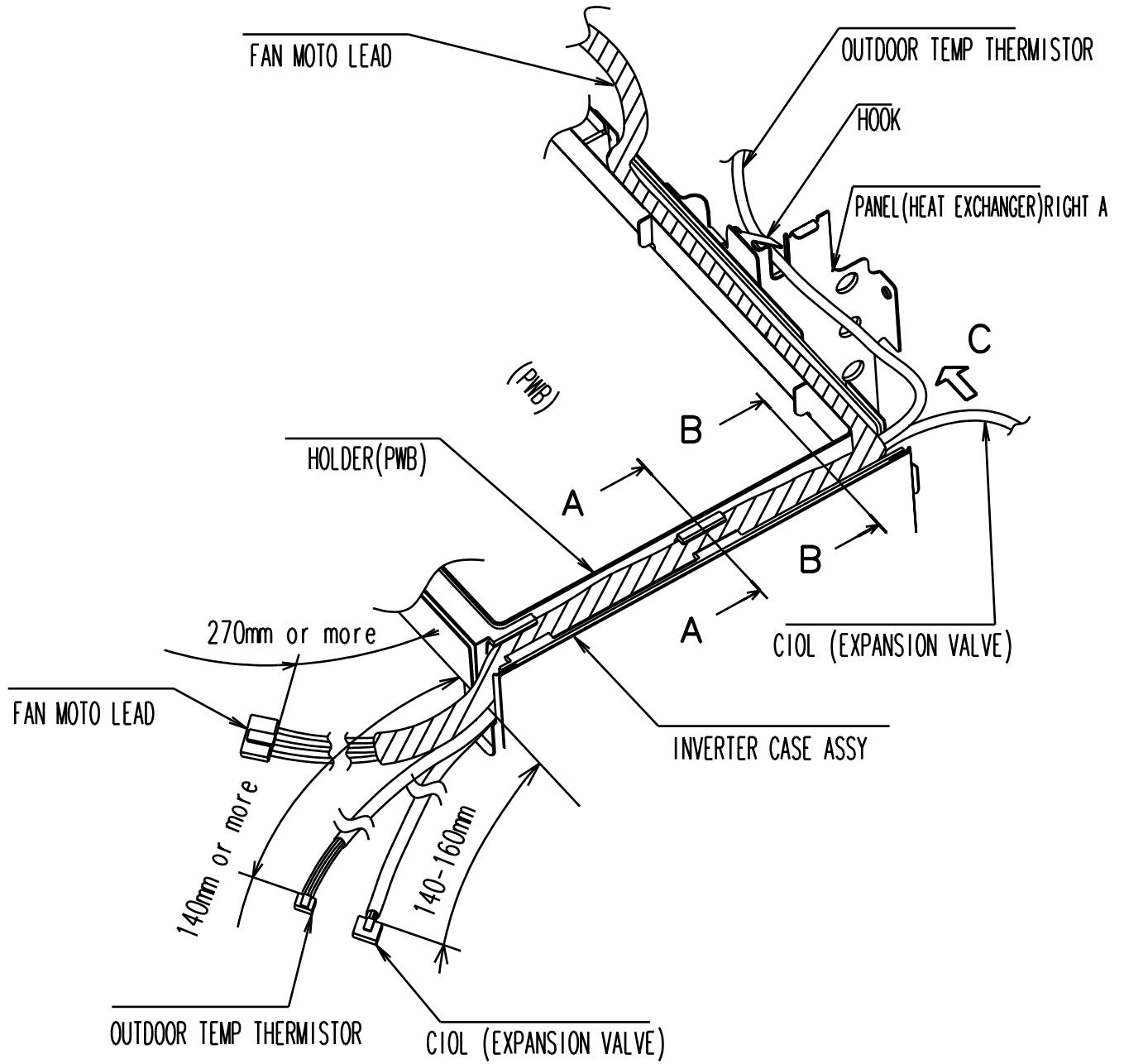

Model : AOYR07/09LCC

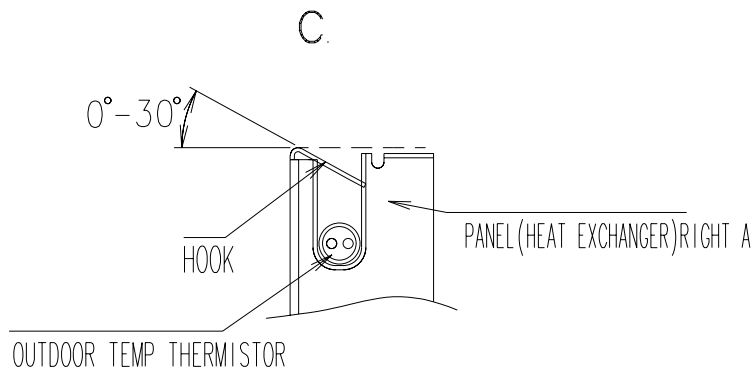
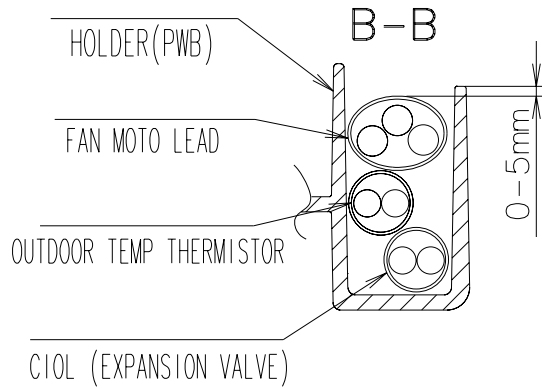
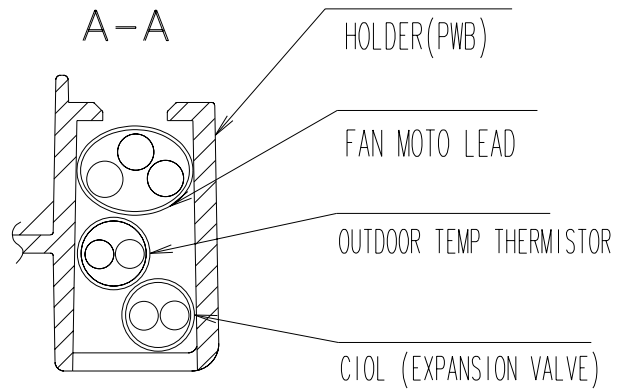

# REPLACEMENT PARTS

Model : AOYR14/18LCC

PROCESS ATTACHMENT OF INVERTER ASSY

- ① INVERTER ASSY
- ② Tap tight screw

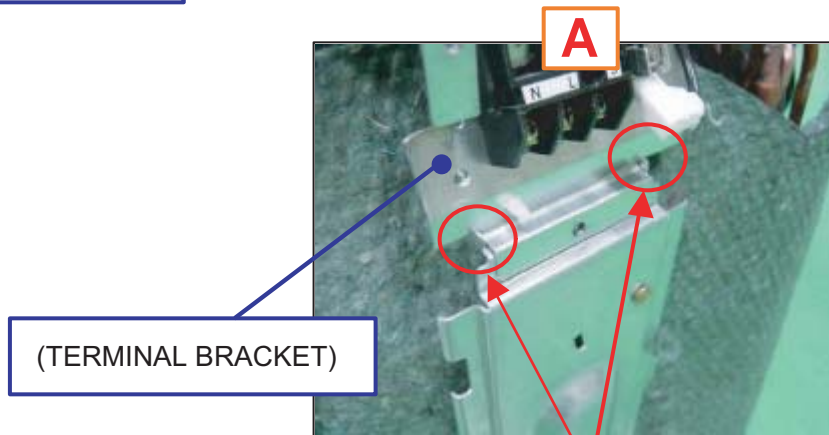

Do not run up the terminal board mounting metal on 2 location of hook.  
THERMISTOR (OUT TEMP) is passed here.

# REPLACEMENT PARTS

Model : AOYR14/18LCC

PROCESS The leads are connected with INVERTER ASSY

- ① MOTOR LEAD
- ② THERMISTOR ASSY (COND, DIS)
- ③ THERMISTOR (OUT TEMP)
- ④ SOLENOID LEAD
- ⑤ COIL (EXP VLV) LEAD
- ⑥ COMP LEAD
- ⑦ WIRE CLAMPER

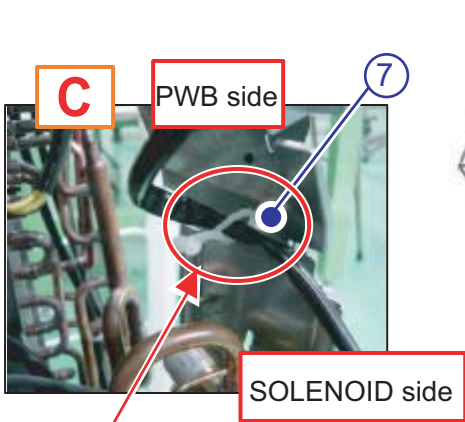
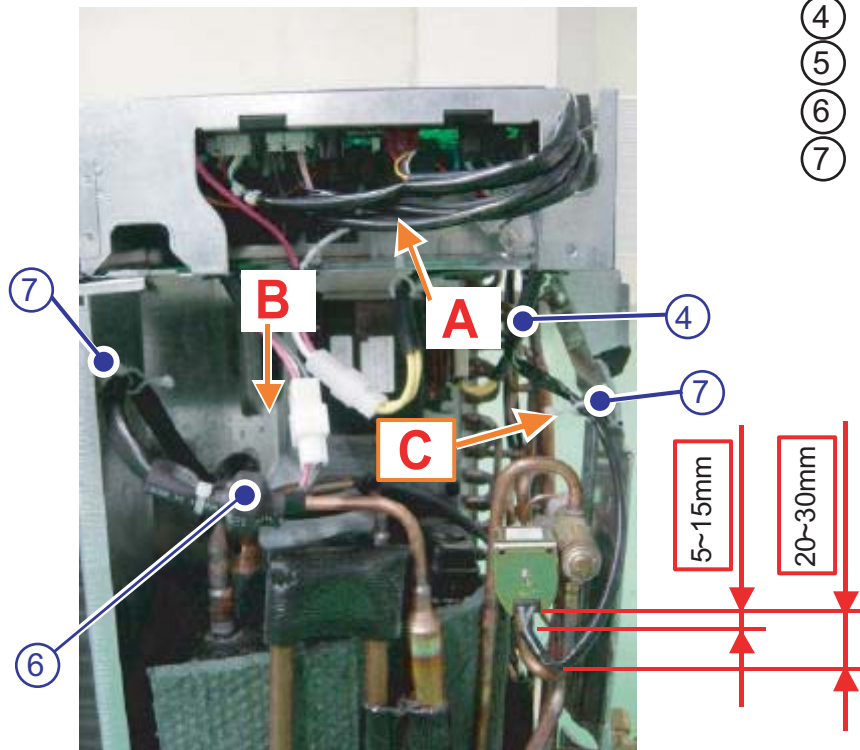

④ is fixed to WAIRE CLAMPER

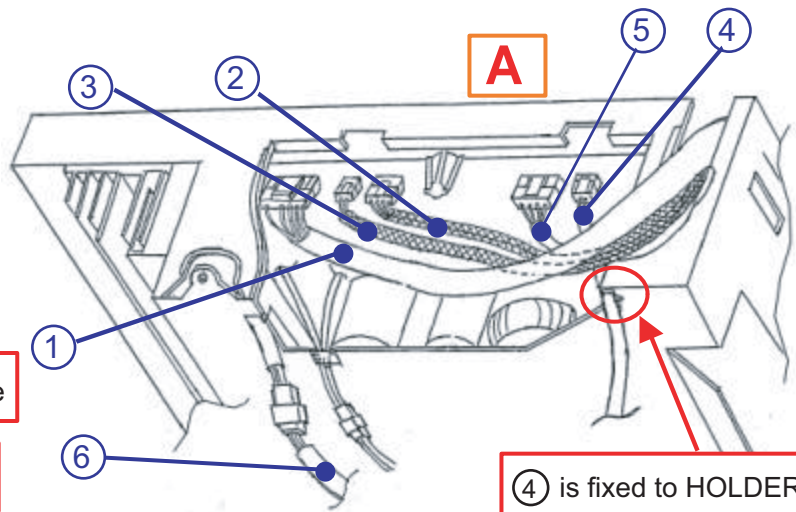

④ is fixed to HOLDER

# REPLACEMENT PARTS

Model : AOYR14/18LCC

PROCESS The leads are connected with INVERTER ASSY

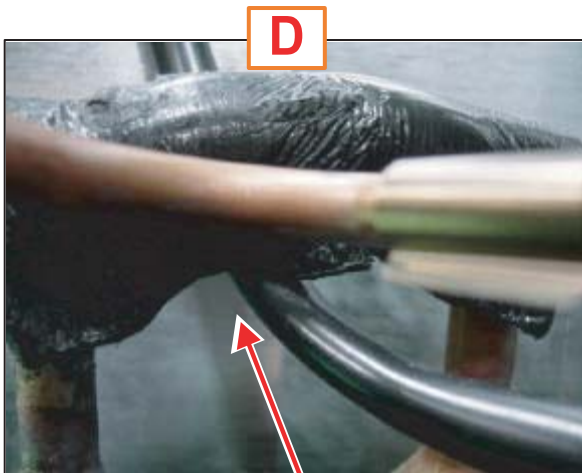
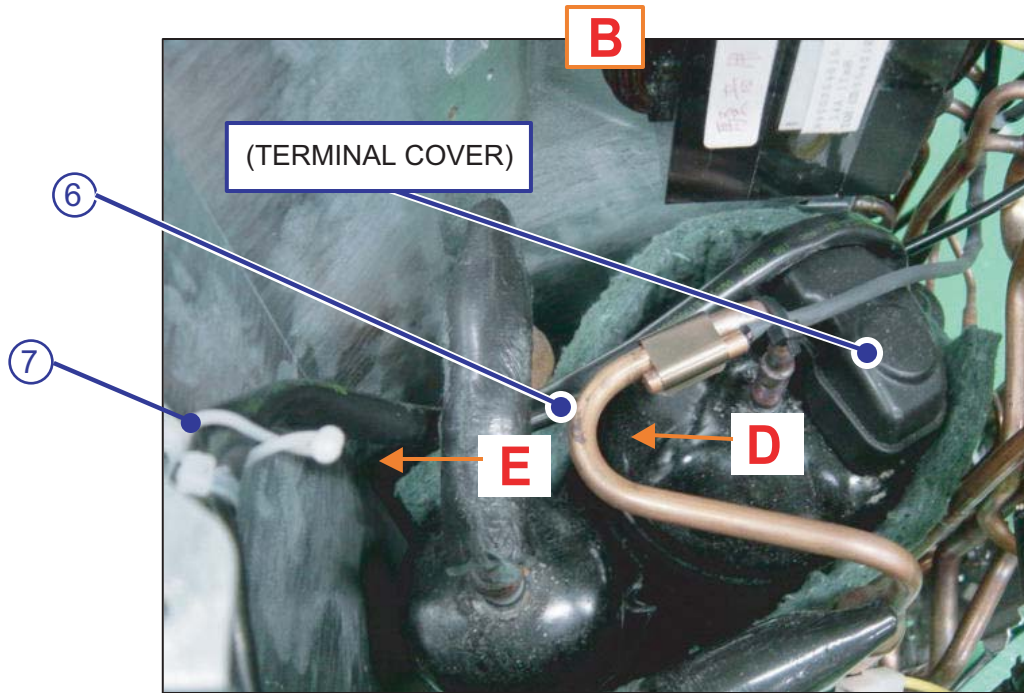

COMP LEAD is passed TERMINAL COVER the under.

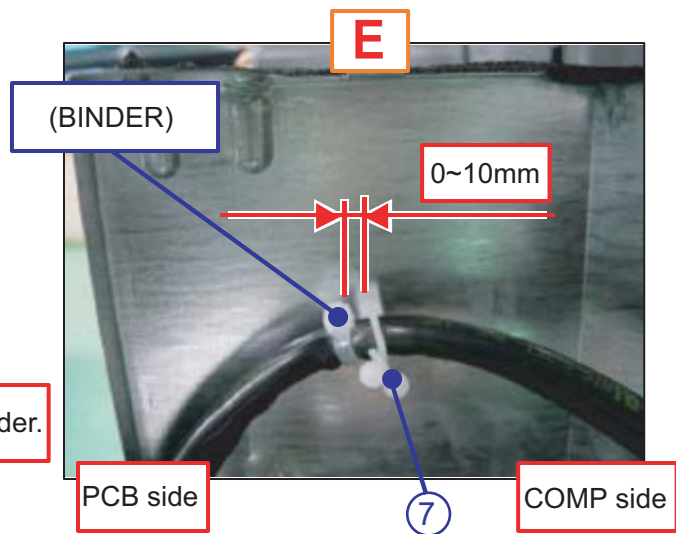

# REPLACEMENT PARTS

Model : AOYR14/18LCC

PROCESS Fixing of Thermistor lead and motor lead.

- ① THERMISTOR ASSY (SUC/DIS)
- ② THERMISTOR (OUT TEMP)
- ③ MOTOR LEAD
- ④ COIL(EXP VLV)

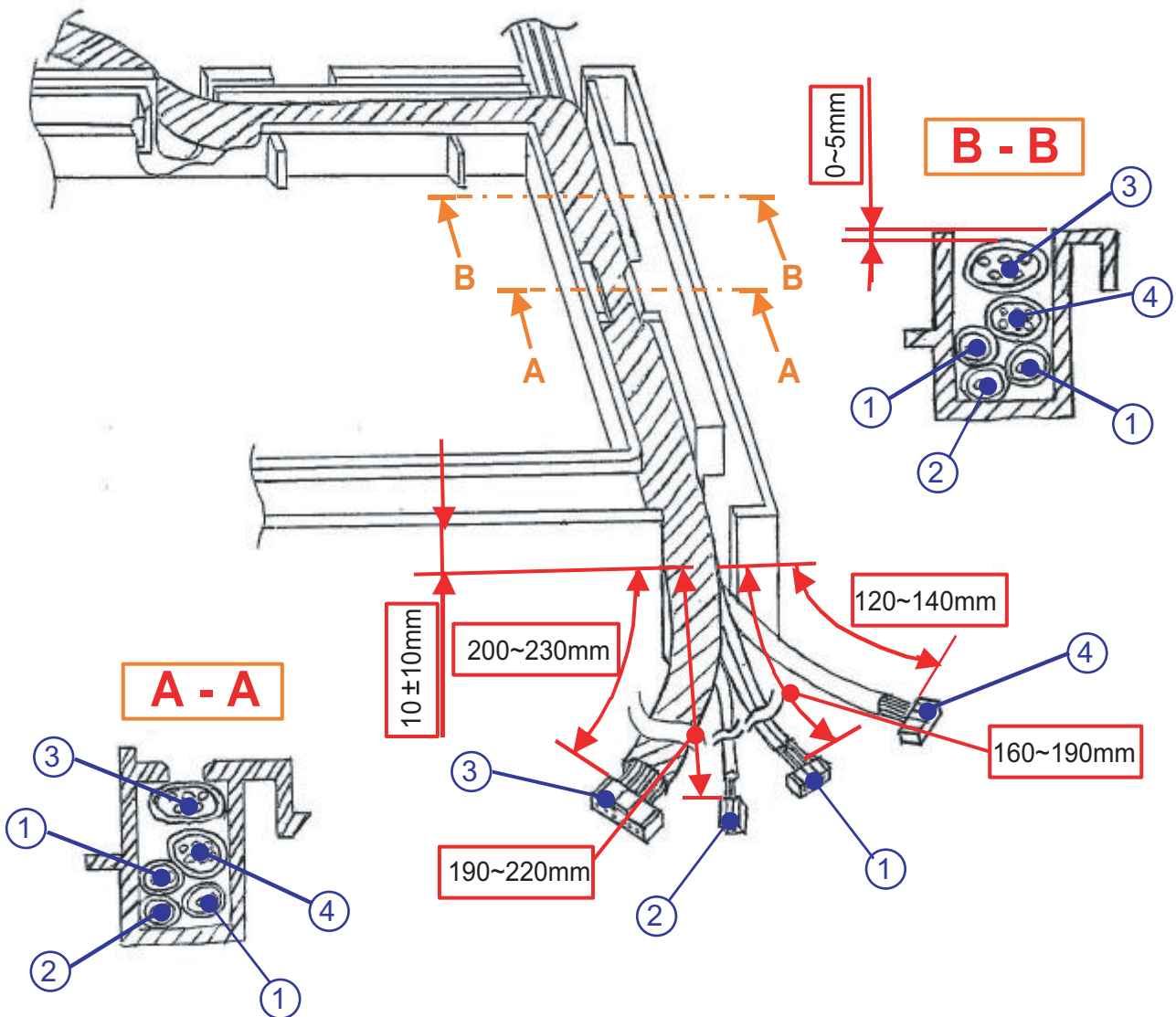

# ***WALL MOUNTED type INVERTER***

## **10 . INSTALLATION MANUAL**

# SPLIT TYPE ROOM AIR CONDITIONER INSTALLATION MANUAL

(PART No. 9315140012-02)

(A12LC)

## This air conditioner uses new refrigerant HFC (R410A).

The basic installation work procedures are the same as conventional refrigerant (R22) models. However, pay careful attention to the following points:

- Since the working pressure is 1.6 times higher than that of conventional refrigerant (R22) models, some of the piping and installation and service tools are special. (See the table below.) Especially, when replacing a conventional refrigerant (R22) model with a new refrigerant R410A model, always replace the conventional piping and flare nuts with the R410A piping and flare nuts.
- Models that use refrigerant R410A have a different charging port thread diameter to prevent erroneous charging with conventional refrigerant (R22) and for safety. Therefore, check beforehand. [The charging port thread diameter for R410A is 1/2 threads per inch.]
- Be more careful that foreign matter (oil, water, etc.) does not enter the piping than with refrigerant (R22) models. Also, when storing the piping, securely seal the opening by pinching, taping, etc.
- When charging the refrigerant, take into account the slight change in the composition of the gas and liquid phases, and always charge from the liquid phase side whose composition is stable.

## Special tools for R410A

Tool name	Contents of change
Gauge manifold	Pressure is high and cannot be measured with a conventional gauge. To prevent erroneous mixing of other refrigerants, the diameter of each port has been changed. It is recommended the gauge with seals -0.1 to 5.3 MPa (-1 to 53 bar) for high pressure. -0.1 to 3.8 MPa (-1 to 38 bar) for low pressure.
Charge hose	To increase pressure resistance, the hose material and base size were changed.
Vacuum pump	A conventional vacuum pump can be used by installing a vacuum pump adapter.
Gas leakage detector	Special gas leakage detector for HFC refrigerant R410A.

## Copper pipes

It is necessary to use seamless copper pipes and it is desirable that the amount of residual oil is less than 40 mg/10m. Do not use copper pipes having a collapsed, deformed or discolored portion (especially on the interior surface). Otherwise, the expansion valve or capillary tube may become blocked with contaminants.

As an air conditioner using R410A incurs pressure higher than when using R22, it is necessary to choose adequate materials. Thicknesses of copper pipes used with R410A are as shown in Table 1. Never use copper pipes thinner than 0.8mm even when it is available on the market.

Table 1 Thicknesses of Annealed Copper Pipes

Nominal diameter	Outer diameter (mm)	Thickness (mm)	
		R410A	[ref.] R22
1/4	6.35	0.80	0.80
3/8	9.52	0.80	0.80

## WARNING

- Do not use the existing (for R22) piping and flare nuts.
  - If the existing materials are used, the pressure inside the refrigerant cycle will rise and cause breakage, injury, etc. (Use the special R410A materials.)
- When installing and relocating the air conditioner, do not mix gases other than the specified refrigerant (R410A) to enter the refrigerant cycle.
  - If air or other gas enters the refrigerant cycle, the pressure inside the cycle will rise to an abnormally high value and cause breakage, injury, etc.

## CAUTION

When installing pipes shorter than 3m, sound of the outdoor unit will be transferred to the indoor unit, which will cause large operating sound or some abnormal sound.

For authorized service personnel only.

## WARNING

- For the room air conditioner to operate satisfactory, install it as outlined in this installation manual.
- Connect the indoor unit and outdoor unit with the air conditioner piping and cords available standards parts. This installation manual describes the correct connections using the standard accessories and the parts specified in this installation manual.
- Have installation work done by authorized service personnel only.
- Never cut the power cord, lengthen or shorten the cord, or change the plug.
- Also do not use an extension cord.
- Plug in the power cord plug firmly. If the receptacle is loose, repair it before using the room air conditioner.
- Do not turn on the power until all installation work is complete.

- Be careful not to scratch the air conditioner when handling it.
- After installation, explain correct operation to the customer, using the operating manual.
- Let the customer keep this installation manual because it is used when the air conditioner is serviced or moved.
- The maximum length of the piping is 20 m. The maximum height difference of the piping is 15 m, if the units are further apart than these, correct operation can not be guaranteed.

## STANDARD ACCESSORIES

The following installation accessories are supplied. Use them as required.

Name and Shape	Q'ty	Name and Shape	Q'ty
Wall hook bracket	1	Cloth tape	1
Remote control unit	1	Tapping screw (big)	8
Battery	2	Tapping screw (small)	2
Remote control unit holder	1	Air cleaning filter	2
Drain pipe	1	Air cleaning filter frame	2

One set of following parts are necessary in installation of this product.

Name
Connection pipe assembly
Connection cord
Wall pipe
Decorative tape
Vinyl tape
Wall cap
Saddle
Drain hose
Tapping screws
Sealant

## ELECTRICAL REQUIREMENT

Always make the air conditioner power supply a special branch circuit and provide a special switch and receptacle. Do not extend the power cord.

## SELECTING THE MOUNTING POSITION

Decide the mounting position with the customer as follows:

### 1. INDOOR UNIT

- Install the indoor unit level on a strong wall which is not subject to vibration.
- The inlet and outlet ports should not be obstructed: the air should be able to blow all over the room.
- Install the unit near an electric outlet or special branch circuit.
- Do not install the unit where it will be exposed to direct sunlight.
- Install the unit where connection to the outdoor unit is easy.
- Install the unit where the drain pipe can be easily installed.
- Take servicing, etc. into consideration and leave the spaces shown in (Fig. 2). Also install the unit where the filter can be removed.

### 2. OUTDOOR UNIT

- If possible, do not install the unit where it will be exposed to direct sunlight. (If necessary, install a blind that does not interfere with the air flow.)
- Do not install the unit where a strong wind blows or where it is very dusty.
- Do not install the unit where people pass.
- Take your neighbors into consideration so that they are not disturbed by air blowing into their windows or by noise.
- Provide the space shown in Fig. 2 so that the air flow is not blocked. Also for efficient operation, leave open three of the four directions front, rear, and both sides.

## WARNING

Install at a place that can withstand the weight of the indoor and outdoor units and install positively so that the units will not topple or fall.

## CAUTION

- Do not install where there is the danger of combustible gas leakage.
- Do not install near heat sources.
- If children under 10 years old may approach the unit, take preventive measures so that they cannot reach the unit.
- Install the indoor unit on the wall where the height from the floors more than 230 cm.

## [Indoor unit piping direction]

The piping can be connected in the five directions indicated by ①, ②, ③, ④, and ⑤ in (Fig. 1). When the piping is connected in direction ② or ③, cut along the piping groove in the side of the front cover with a hacksaw.

When connecting the piping in direction ③, cut a notch in the thin wall at the front bottom of the front cover.

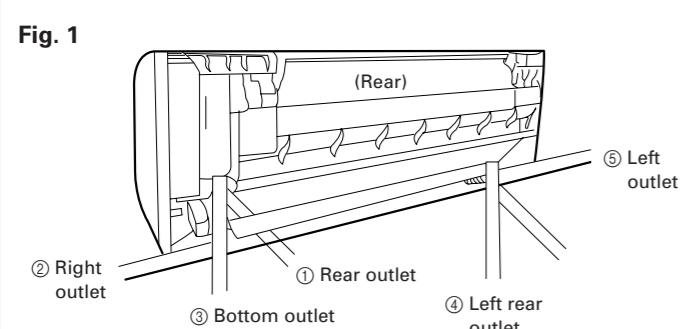

## INSTALLATION DIAGRAM OF INDOOR AND OUTDOOR UNITS

Fig. 2

### [INDOOR UNIT]

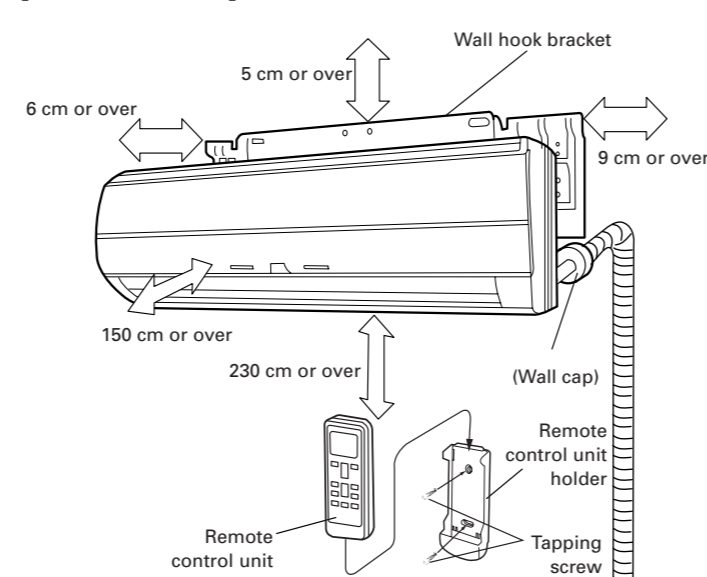

### [OUTDOOR UNIT]

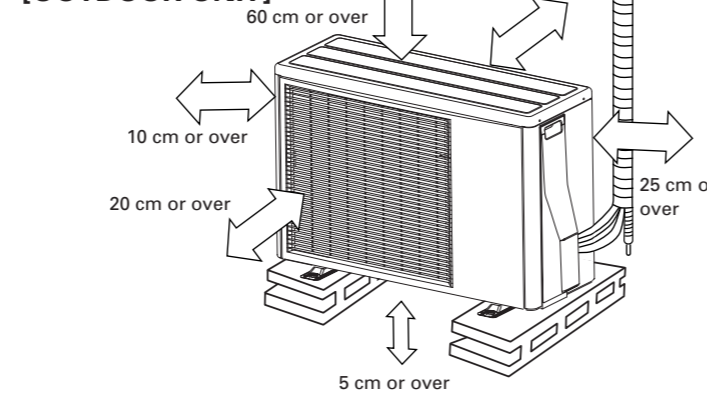
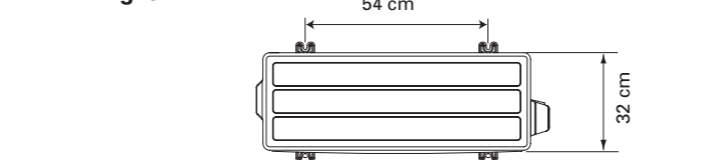

Fig. 3



## NOTE:

In places where the outdoor temperature drops to 0°C or lower, the drain water may freeze and may stop up the drain or cause other outdoor unit trouble. Therefore take measures so that the drain water will not freeze and clog the drain.

## FRONT PANEL REMOVAL AND INSTALLATION

### THE INTAKE GRILLE REMOVAL

- Open the intake grille.
- Pull down the knob.
- Lift the intake grille upward, until the axle at the top of the intake grille is removed.

### THE INTAKE GRILLE INSTALLATION

- The fixing axle of the intake grille is installed on the Panel.
- Lay down the intake grille.

### THE FRONT PANEL REMOVAL

- Remove intake grille (Reference the intake grille removal.)
- Remove four screws.
- The thumb is hung on the lower part as shown in the figure, and it pulls to the front, pushing [-] mark, and bottom hooks (two position) is removed from wall hook bracket.
- The front panel bottom is pulled to the front, and bottom hooks is removed indoor unit.
- The front panel is pulled to the front, raising the upper surface, and a front panel is removed.

### THE FRONT PANEL INSTALLATION

- Firstly, fit the lower part of the front panel, and insert top and bottom hooks. (Three top sides, six bottom sides)
- Four screws is attached.
- The intake grille is attached.

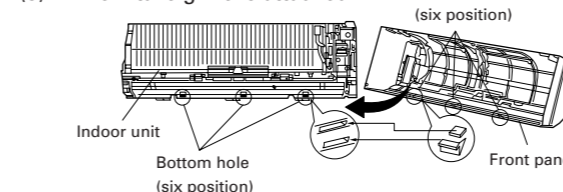
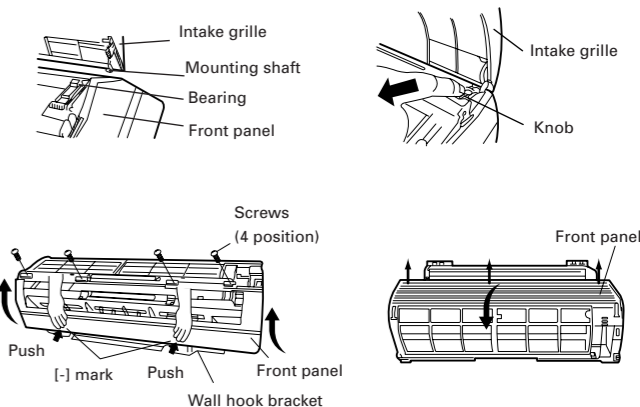

Fig. 4



## CAUTION

Install the front panel and INTAKE GRILLE securely. If installation is imperfect, the front panel or INTAKE GRILLE may fall off and cause injury.

Be sure that the top hole of the front panel is hooked securely to the hook of the base.

## CUSTOMER GUIDANCE

Explain the following to the customer in accordance with the operating manual:

- Starting and stopping method, operation switching, temperature adjustment, timer, air flow switching, and other remote control unit operations.
- Air filter removal and cleaning, and how to use the air louvers.
- Give the operating and installation manuals to the customer.

## PUMP DOWN OPERATION (FORCED COOLING OPERATION)

To avoid discharging refrigerant into the atmosphere at the time of relocation or disposal, recover refrigerant by doing the cooling operation or forced cooling operation according to the following procedure. (When the cooling operation cannot start in winter, and so on, start the forced cooling operation.)

- Do the air purging of the charge hose by connecting the charging hose of gauge manifold to the charging port of 3 way valve and opening the low-pressure valve slightly.
- Close the valve stem of 2 way valve completely.
- Start the cooling operation or following forced cooling operation.
  - When using the remote control unit: Press the TEST RUN button after starting the cooling operation by the remote control unit. The operation indicator lamp and timer indicator lamp will begin to flash simultaneously during test run. When using the MANUAL AUTO button of the indoor unit (The remote control unit is lost, and so on.) Keep on pressing the MANUAL AUTO button of the indoor unit for more than 10 seconds. (The forced cooling operation cannot start if the MANUAL AUTO button is not kept on pressing for more than 10 seconds.)
  - Close the valve stem of 3 way valve when the reading on the compound pressure gage becomes 0.05-0 Mpa (0.5-0 kg/cm<sup>2</sup>).
  - Stop the operation.
    - Press the START/STOP button of the remote control unit to stop the operation.
    - Press the MANUAL AUTO button when stopping the operation from indoor unit side. (It is not necessary to press on keeping for more than 10 seconds.)

## CAUTION

During the pump-down operation, make sure that the compressor is turned off before you remove the refrigerant piping. Do not remove the connection pipe while the compressor is in operation with 2 way or 3 way valve open. This may cause abnormal pressure in the refrigeration cycle that leads to breakage and even injury.

## POWER

## WARNING

- The rated voltage of this product is 230 V AC 50 Hz.
- Before turning on the power, check if the voltage is within the 220 V -10% to 240 V +10% range.
- Always use a special branch circuit and install a special receptacle to supply power to the room air conditioner.
- Use a circuit breaker and receptacle matched to the capacity of the air conditioner.
- Do not extend the power cord.
- Perform wiring work in accordance with standards so that the air conditioner can be operated safely and positively.
- Install a leakage circuit breaker in accordance with the related laws and regulations and electric company standards.

## CAUTION

- The power source capacity must be the sum of the air conditioner current and the current of other electrical appliances. When the current contracted capacity is insufficient, change the contracted capacity.
- When the voltage is low and the air conditioner is difficult to start, contact the power company the voltage raised.

Installation instruction on the back.



# INDOOR UNIT

## CUTTING THE HOLE IN THE WALL FOR THE CONNECTING PIPING

- Cut a 65 mm diameter hole in the wall at the position shown in (Fig. 5).
- When cutting the wall hole at the inside of the wall hook bracket, cut the hole within the range of the left and right center marks 40 mm below the wall hook bracket.  
When cutting the wall hole at the outside of the wall hook bracket, cut the hole at least 10 mm below over.
- Cut the hole so that the outside end is lower (5 to 10 mm) than the inside end.
- Always align the center of the wall hole. If misaligned, water leakage will occur.
- Cut the wall pipe to match the wall thickness, stick it into the wall cap, fasten the cap with vinyl tape, and stick the pipe through the hole. (The connection pipe is supplied in the installation set.) (Fig. 5)
- For left piping and right piping, cut the hole a little lower so that drain water will flow freely. (Fig. 5)

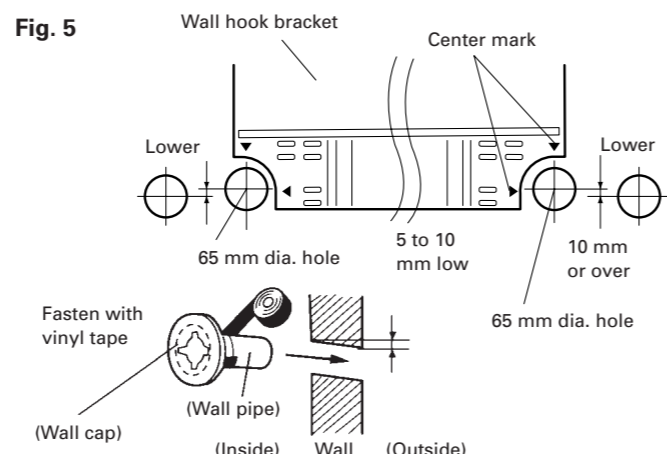

## INSTALLING THE WALL HOOK BRACKET

- Install the wall hook bracket so that it is correctly positioned horizontally and vertically. If the wall hook bracket is tiled, water will drip to the floor.
  - Install the wall hook bracket so that it is strong enough to withstand the weight of an adult.
- Fasten the wall hook bracket to the wall with 6 or more screws through the holes near the outer edge of the bracket.
  - Check that there is no rattle at the wall hook bracket.

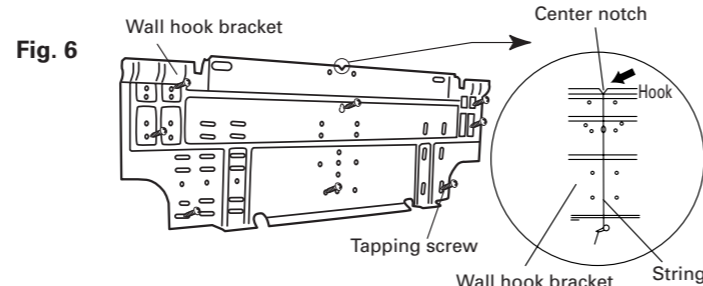

### WARNING

If the wall pipe is not used, the cord interconnecting the indoor and outdoor units may touch metal and cause electric leakage.

### CAUTION

Install the wall hook bracket horizontally and perpendicularly.

## FORMING THE DRAIN HOSE AND PIPE

### [Rear piping, Right piping, Bottom piping]

- Install the indoor unit piping in the direction of the wall hole and bind the drain hose and pipe together with vinyl tape. (Fig. 7)
- Install the piping so that the drain hose is at the bottom.
- Wrap the pipes of the indoor unit that are visible from the outside with decorative tape.

### [For Left rear piping, Left piping]

Interchange the drain cap and the drain hose.

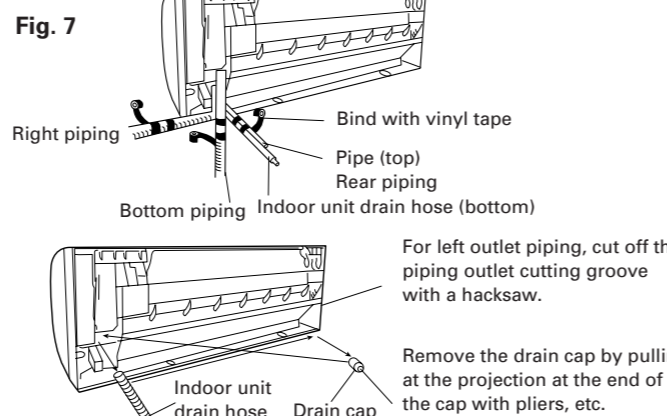

### CAUTION

- In order to align the drain hose and drain cap, be sure to insert securely and vertically. Incline insertion will cause water leakage.
- When inserting, be sure not to attach any material besides water. If any other material is attached, it will cause deterioration and water leakage.
- After removing drain hose, be sure not to forget mounting drain cap.
- Be sure to fix the drain hose with tape to the bottom of piping.

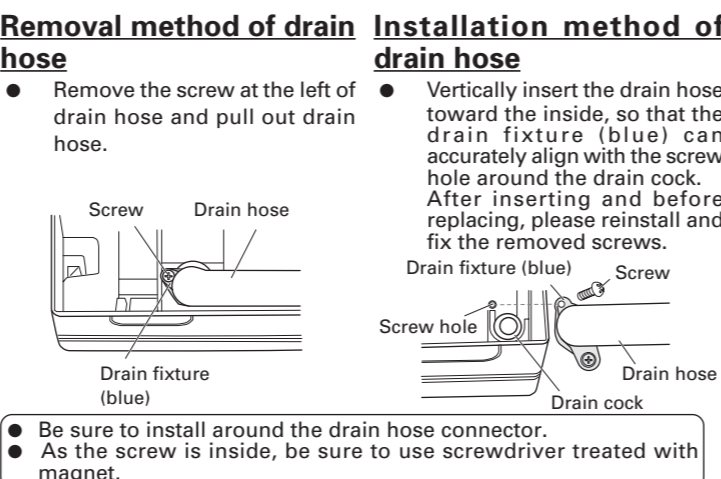

- Be sure to install around the drain hose connector.
- As the screw is inside, be sure to use screwdriver treated with magnet.

- For left piping and left rear piping, align the marks on the wall hook bracket and shape the connection pipe.
- Bend the connection piping at the bend radius of 70 mm or more and install no more than 35 mm from the wall.
- After passing the indoor piping and drain hose through the wall hole, hang the indoor unit on the hooks at the top and bottom of the wall hook bracket.

### [Installing the indoor unit]

- Hang the indoor unit from the hooks at the top of the wall hook bracket.
- Insert the spacer, etc. between the indoor unit and the wall hook bracket and separate the bottom of the indoor unit from the wall.

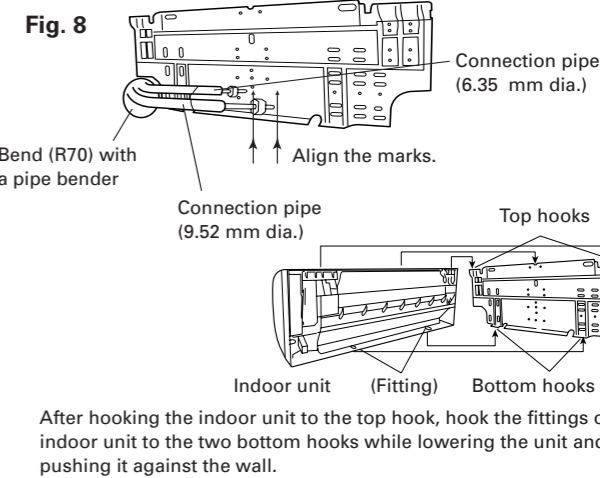
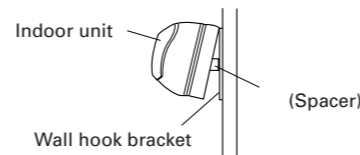

## CONNECTING THE PIPING

### CONNECTION

- Install the outdoor unit wall cap (supplied with the optional installation set or procured at the site) to the wall pipe.
- Connect the outdoor unit and indoor unit piping.
- After matching the center of the flare surface and tightening the nut hand tight, tighten the nut to the specified tightening torque with a torque wrench. (Table 2)

### FLARING

- Cut the connection pipe to the necessary length with a pipe cutter.
- Hold the pipe downward so that cuttings will not enter the pipe and remove the burrs.
- Insert the flare nut onto the pipe and flare the pipe with a flaring tool.

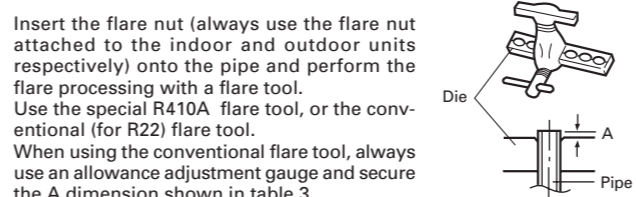

Insert the flare nut (always use the flare nut attached to the indoor and outdoor units respectively) onto the pipe and perform the flare processing with a flare tool.

Use the special R410A flare tool, or the conventional (for R22) flare tool.

When using the conventional flare tool, always use an allowance adjustment gauge and secure the A dimension shown in table 3.

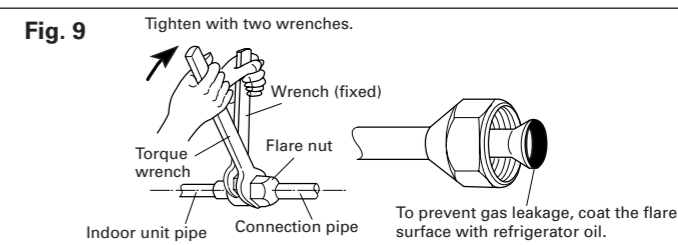

Table 2 Flare nut tightening torque

Flare nut	Tightening torque	Tightening torque standard (using a 20 cm wrench)
6.35 mm dia.	15.7 to 17.6 N·m (160 to 180 kgf·cm)	Wrist strength
9.52 mm dia.	29.4 to 41.1 N·m (300 to 420 kgf·cm)	Arm strength

Table 3 Pipe outside diameter

Pipe outside diameter	A (mm)		
	Flash tool for R410A, clutch type	Conventional (R22) flare tool Clutch type	Wing nut type
φ 6.35 mm (1/4")	0 to 0.5	1.0 to 1.5	1.5 to 2.0
φ 9.52 mm (3/8")	0 to 0.5	1.0 to 1.5	1.5 to 2.0

### CAUTION

- Fasten a flare nut with a torque wrench as instructed in this manual. If fastened too tight, the flare nut may be broken after a long period of time and cause a leakage of refrigerant.
- During installation, make sure that the refrigerant pipe is attached firmly before you run the compressor. Do not operate the compressor under the condition of refrigerant piping not attached properly with 2-way or 3-way valve open. This may cause abnormal pressure in the refrigeration cycle that leads to breakage and even injury.

## INDOOR UNIT WIRING

- Remove the cord clamp.
- Bend the end of the connection cord as shown in the figure.

- Connect the end of the connection cord fully into the terminal block.
- Fasten the connection cord with a cord clamp.

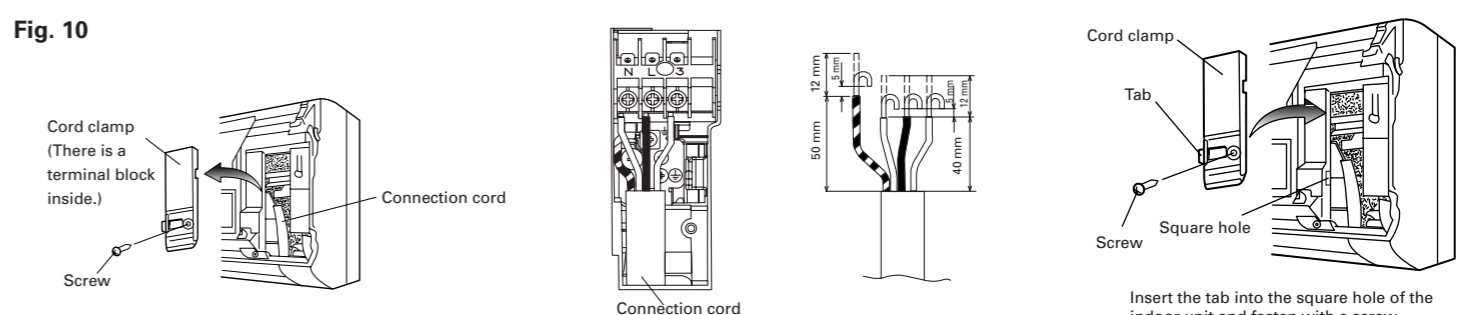

### CAUTION

- Match the terminal block numbers and connection cord colors with those of the outdoor unit. Erroneous wiring may cause burning of the electric parts.
- Connect the connection cords firmly to the terminal block. Imperfect installation may cause a fire.
- Always fasten the outside covering of the connection cord with the cord clamp. (If the insulator is chafed, electric leakage may occur.)
- Securely earth the power cord plug.
- Do not use the earth screw for an external connector. Only use for interconnection between two units.

# OUTDOOR UNIT

## OUTDOOR UNIT INSTALLATION

- Set the unit on a strong stand, such as one made of concrete blocks to minimize shock and vibration.
- Do not set the unit directly on the ground because it will cause trouble.

### Connector cover removal

- Remove the tapping screws.

### Installing the connector cover

- After inserting the two front hooks, then insert the rear hook.
- Tighten the tapping screws.

### WARNING

- Install the unit where it will not be tilted by more than 5°.
- When installing the outdoor unit where it may be exposed to strong wind, fasten it securely.

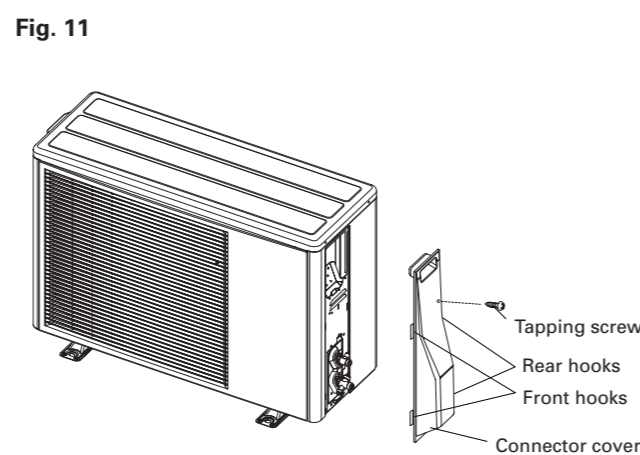

## AIR PURGE

Always use a vacuum pump to purge the air. Refrigerant for purging the air is not charged in the outdoor unit at the factory.

Close the high pressure side valve of the gauge manifold fully and do not operate it during the following work.

- Check if the piping connections are secure.
- Check that the stems of 2-way valve and 3-way valve are closed fully.
- Connect the gauge manifold charge hose to the charging port of the 3-way valve (side with the projection for pushing in the valve core).
- Open the low pressure side valve of the gauge manifold fully.
- Operate the vacuum pump and start pump down.
- Slowly loosen the flare nut of the 3-way valve and check if air enters, then retighten the flare nut. (When the flare nut is loosened the operating sound of the vacuum pump changes and the reading of the compound pressure gauge goes from minus to zero.)
- Pump down the system for at least 15 minutes, then check if the compound pressure gauge reads -0.1 MPa (-76 cmHg, -1 bar).
- At the end of pump down, close the low pressure side gauge of the gauge manifold fully and stop the vacuum pump.
- Slowly loosen the valve stem of the 3-way valve. When the compound pressure gauge reading reaches 0.1-0.2 MPa, retighten the valve stem and disconnect the charge hose from the 3-way valve charging port. (If the stem of the 3-way valve is opened fully before the charge hose is disconnected, it may be difficult to disconnect the charge hose.)

### Additional charge

Refrigerant suitable for a piping length of 15 m is charged in the outdoor unit at the factory. When the piping is longer than 15 m, additional charging is necessary. For the additional amount, see the table below.

Pipe length	15 m	20 m
Additional refrigerant	None	100 g

- Refrigerant must not be discharged into atmosphere.
- After connecting the piping, check the joints for gas leakage with gas leak detector.

- Fully open the valve stems of the 2-way valve and 3-way valve using a hexagon wrench. (After the valve stem begins to turn, turn it with a torque of less than 2.9 N·m (30 kgf·cm) until it stops turning.)
- Firmly tighten the 2-way valve and 3-way valve blank cap and the charging port cap.

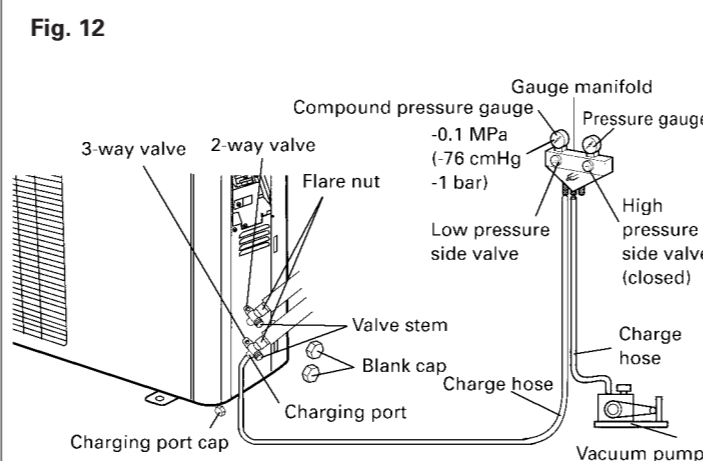

	Tightening torque
Blank cap	19.6 to 24.5 N·m (200 to 250 kgf·cm)
Charging port cap	12.3 to 15.7 N·m (125 to 160 kgf·cm)

### CAUTION

- When adding refrigerant, add the refrigerant from the charging port at the completion of work.
- The maximum length of the piping is 20 m. If the units are further apart than this, correct operation cannot be guaranteed.

Between 15 m and 20 m, when using a connection pipe other than that in the table, charge additional refrigerant with 20g/1 m as the criteria.

## OUTDOOR UNIT WIRING

- Remove the outdoor unit connector cover.
- Bend the end of the cord as shown in the figure.
- Connect the end of the connection cord fully into the terminal block.
- Fasten the sheath with a cord clamp.
- Install the connector cover.

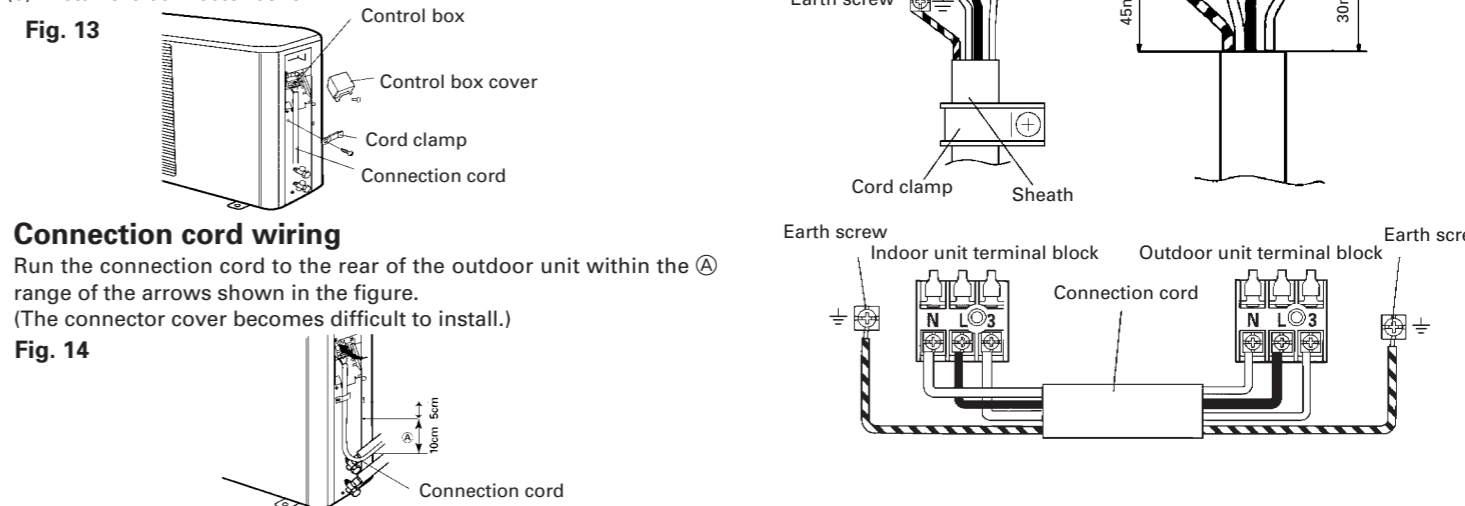

### Connection cord wiring

Run the connection cord to the rear of the outdoor unit within the range of the arrows shown in the figure. (The connector cover becomes difficult to install.)

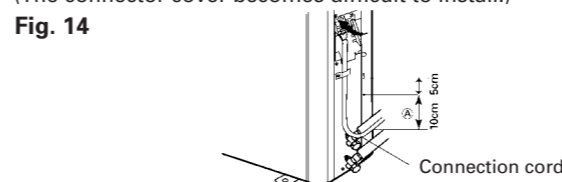

### CAUTION

- Match the terminal block numbers and connection cord colors with those of the indoor unit. Erroneous wiring may cause burning of the electric parts.
- Connect the connection cords firmly to the terminal block. Imperfect installation may cause a fire.
- Always fasten the outside covering of the connection cord with the cord clamp. (If the insulator is chafed, electric leakage may occur.)
- Securely earth the power cord plug.
- Do not use the earth screw for an external connector. Only use for interconnection between two units.

## FINISHING

- Insulate between pipes.
  - For rear, right, and bottom piping, overlap the connection pipe heat insulation and indoor unit pipe heat insulation and bind them with vinyl tape so that there is no gap.
  - For left and left rear piping, butt the connection pipe heat insulation and indoor unit pipe heat insulation together and bind them with vinyl tape so that there is no gap.
  - For left and left rear piping, wrap the area which accommodates the rear piping housing section with cloth tape.
  - For left and left rear piping, bind the connection cord to the top of the pipe with vinyl tape.
  - For left and left rear piping, bundle the piping and drain hose together by wrapping them with cloth tape over the range within which they fit into the rear piping housing section.
- Temporarily fasten the connection cord along the connection pipe with vinyl tape. (Wrap to about 1/3 the width of the tape from the bottom of the pipe so that water does not enter.)
- Fasten the connection pipe to the outside wall with saddles, etc.
- Fill the gap between the outside wall pipe hole and the pipe with sealer so that rain water and wind cannot blow in.
- Fasten the drain hose to the outside wall, etc.

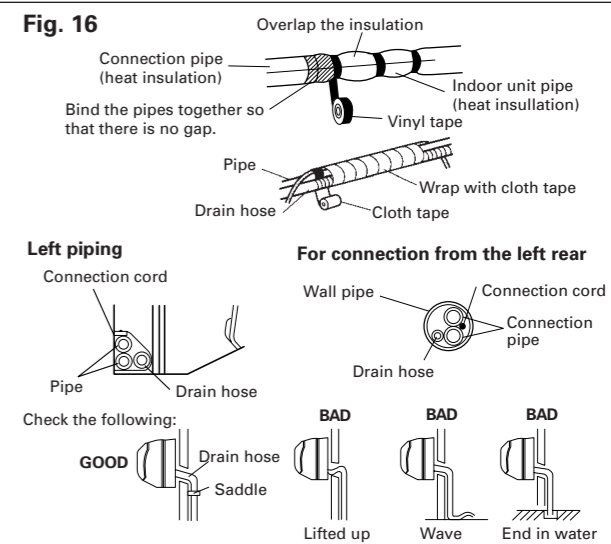
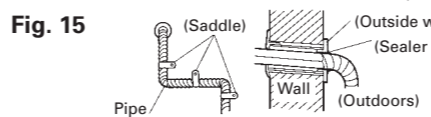

## TEST RUNNING

- Perform test operation and check items 1 and 2 below.
  - For the test operation method, refer to the operating manual.
  - The outdoor unit, may not operate, depending on the room temperature. In this case, press the test run button on the remote control unit while the air conditioner is running. (Point the transmitter section of the remote control unit toward the air conditioner and press the test run button with the tip of a ball-point pen, etc.)
  - To end test operation, press the remote control unit START/STOP button. (When the air conditioner is run by pressing the test run button, the OPERATION indicator lamp and TIMER indicator lamp will simultaneously flash slowly.)
- INDOOR UNIT
    - Is operation of each button on the remote control unit normal?
    - Does each lamp light normally?
    - Do the air flow-direction louvers operate normally?
    - Is the drain normal?
  - OUTDOOR UNIT
    - Is there any abnormal noise and vibration during operation?
    - Will noise, wind, or drain water from the unit disturb the neighbors?
    - Is there any gas leakage?

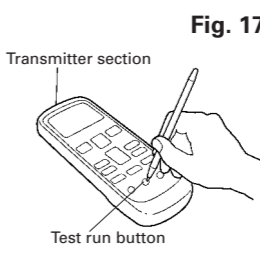

# SPLIT TYPE ROOM AIR CONDITIONER INSTALLATION MANUAL

(PART NO. 9314989018-01)

## This air conditioner uses new refrigerant HFC (R410A).

The basic installation work procedures are the same as conventional refrigerant (R22) models. However, pay careful attention to the following points:

- Since the working pressure is 1.6 times higher than that of conventional refrigerant (R22) models, some of the piping and installation and service tools are special. (See the table below.) Especially, when replacing a conventional refrigerant (R22) model with a new refrigerant R410A model, always replace the conventional piping and flare nuts with the R410A piping and flare nuts.
- Models that use refrigerant R410A have a different charging port thread diameter to prevent erroneous charging with conventional refrigerant (R22) and for safety. Therefore, check beforehand. [The charging port thread diameter for R410A is 1/2 threads per inch.]
- Be more careful that foreign matter (oil, water, etc.) does not enter the piping than with refrigerant (R22) models. Also, when storing the piping, securely seal the opening by pinching, taping, etc.
- When charging the refrigerant, take into account the slight change in the composition of the gas and liquid phases, and always charge from the liquid phase side whose composition is stable.

## Special tools for R410A

Tool name	Contents of change
Gauge manifold	Pressure is high and cannot be measured with a conventional gauge. To prevent erroneous mixing of other refrigerants, the diameter of each port has been changed. It is recommended the gauge with seals-0.1 to 5.3 MPa (-1 to 53 bar) for high pressure. -0.1 to 3.8 MPa (-1 to 38 bar) for low pressure.
Charge hose	To increase pressure resistance, the hose material and base size were changed.
Vacuum pump	A conventional vacuum pump can be used by installing a vacuum pump adapter.
Gas leakage detector	Special gas leakage detector for HFC refrigerant R410A.

## Copper pipes

It is necessary to use seamless copper pipes and it is desirable that the amount of residual oil is less than 40 mg/10m. Do not use copper pipes having a collapsed, deformed or discolored portion (especially on the interior surface). Otherwise, the expansion valve or capillary tube may become blocked with contaminants.

As an air conditioner using R410A incurs pressure higher than when using R22, it is necessary to choose adequate materials. Thicknesses of copper pipes used with R410A are as shown in Table 1. Never use copper pipes thinner than 0.8mm even when it is available on the market.

Table 1 Thicknesses of Annealed Copper Pipes

Nominal diameter	Outer diameter (mm)	Thickness (mm)	
		R410A	[ref.] R22
1/4	6.35	0.80	0.80
3/8	9.52	0.80	0.80

## WARNING

- Do not use the existing (for R22) piping and flare nuts.
  - If the existing materials are used, the pressure inside the refrigerant cycle will rise and cause breakage, injury, etc. (Use the special R410A materials.)
- When installing and relocating the air conditioner, do not mix gases other than the specified refrigerant (R410A) to enter the refrigerant cycle.
  - If air or other gas enters the refrigerant cycle, the pressure inside the cycle will rise to an abnormally high value and cause breakage, injury, etc.

For authorized service personnel only.

## WARNING

- For the room air conditioner to operate satisfactorily, install it as outlined in this installation manual.
- Connect the indoor unit and outdoor unit with the air conditioner piping and cords available standards parts. This installation manual describes the correct connections using the standard accessories and the parts specified in this installation manual.
- Have installation work done by authorized service personnel only.
- Never cut the power cord, lengthen or shorten the cord, or change the plug.
- Also do not use an extension cord.
- Plug in the power cord plug firmly. If the receptacle is loose, repair it before using the room air conditioner.
- Do not turn on the power until all installation work is complete.

- Be careful not to scratch the air conditioner when handling it.
- After installation, explain correct operation to the customer, using the operating manual.
- Let the customer keep this installation manual because it is used when the air conditioner is serviced or moved.
- The maximum length of the piping is 20 m. The maximum height difference of the piping is 15 m, if the units are further apart than these, correct operation can not be guaranteed.

## STANDARD ACCESSORIES

The following installation accessories are supplied. Use them as required.

Name and Shape	Q'ty	Name and Shape	Q'ty
Wall hook bracket	1	Cloth tape	1
Remote control unit	1	Tapping screw (big)	8
Battery	2	Tapping screw (small)	2
Remote control unit holder	1	Air-cleaning and Deodorizing filter	1
Drain pipe	1		

One set of following parts are necessary in installation of this product.

Name
Connection pipe assembly
Connection cord
Wall pipe
Decorative tape
Vinyl tape
Wall cap
Saddle
Drain hose
Tapping screws
Sealant

## ELECTRICAL REQUIREMENT

Always make the air conditioner power supply a special branch circuit and provide a special switch and receptacle. Do not extend the power cord.

## SELECTING THE MOUNTING POSITION

Decide the mounting position with the customer as follows:

### 1. INDOOR UNIT

- Install the indoor unit level on a strong wall which is not subject to vibration.
- The inlet and outlet ports should not be obstructed: the air should be able to blow all over the room.
- Install the unit near an electric outlet or special branch circuit.
- Do not install the unit where it will be exposed to direct sunlight.
- Install the unit where connection to the outdoor unit is easy.
- Install the unit where the drain pipe can be easily installed.
- Take servicing, etc. into consideration and leave the spaces shown in (Fig. 2). Also install the unit where the filter can be removed.

### 2. OUTDOOR UNIT

- If possible, do not install the unit where it will be exposed to direct sunlight. (If necessary, install a blind that does not interfere with the air flow.)
- Do not install the unit where a strong wind blows or where it is very dusty.
- Do not install the unit where people pass.
- Take your neighbors into consideration so that they are not disturbed by air blowing into their windows or by noise.
- Provide the space shown in Fig. 2 so that the air flow is not blocked. Also for efficient operation, leave open three of the four directions front, rear, and both sides.

## WARNING

Install at a place that can withstand the weight of the indoor and outdoor units and install positively so that the units will not topple or fall.

## CAUTION

- Do not install where there is the danger of combustible gas leakage.
- Do not install near heat sources.
- If children under 10 years old may approach the unit, take preventive measures so that they cannot reach the unit.
- Install the indoor unit on the wall where the height from the floors more than 230 cm.

### [Indoor unit piping direction]

The piping can be connected in the five directions indicated by ①, ②, ③, ④, and ⑤ in (Fig. 1). When the piping is connected in direction ② or ③, cut along the piping groove in the side of the front cover with a hacksaw. When connecting the piping in direction ③, cut a notch in the thin wall at the front bottom of the front cover.

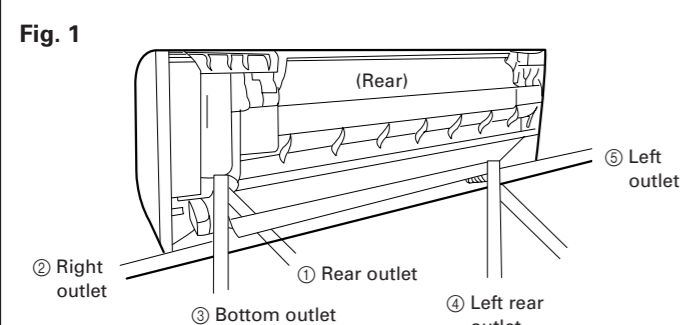

## INSTALLATION DIAGRAM OF INDOOR AND OUTDOOR UNITS

Fig. 2

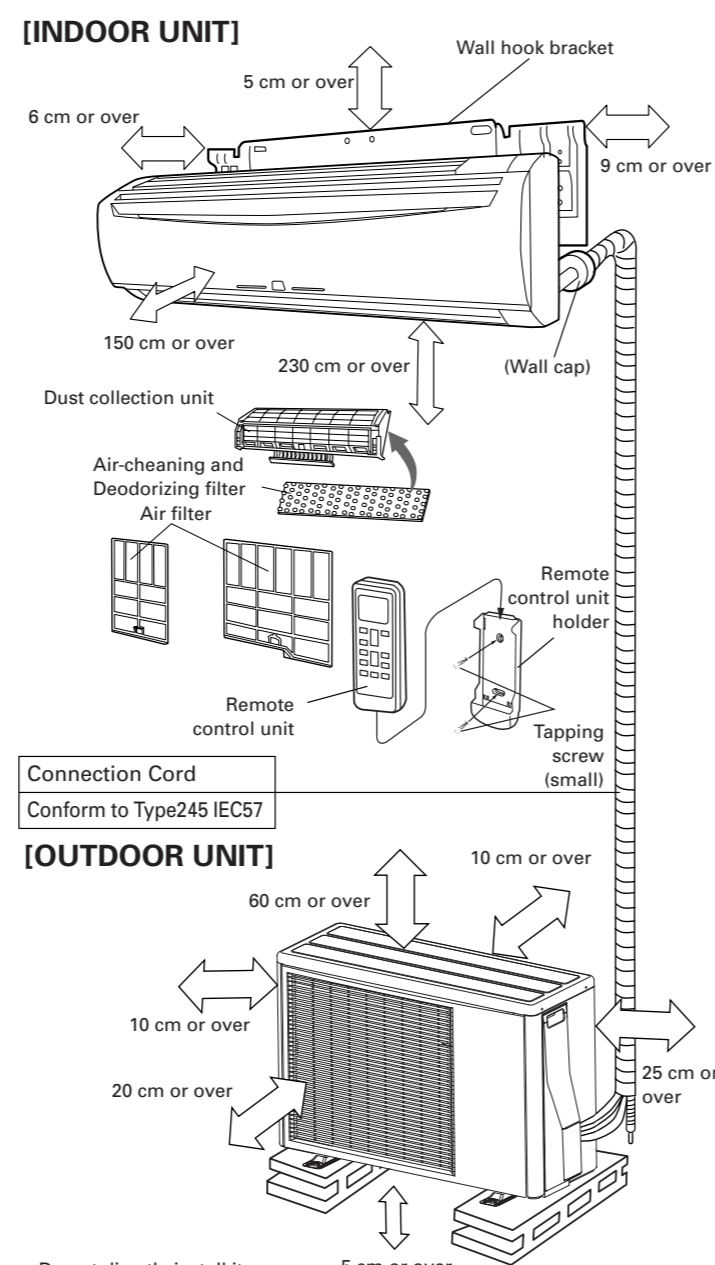

Do not directly install it on the ground, otherwise it will cause failure.

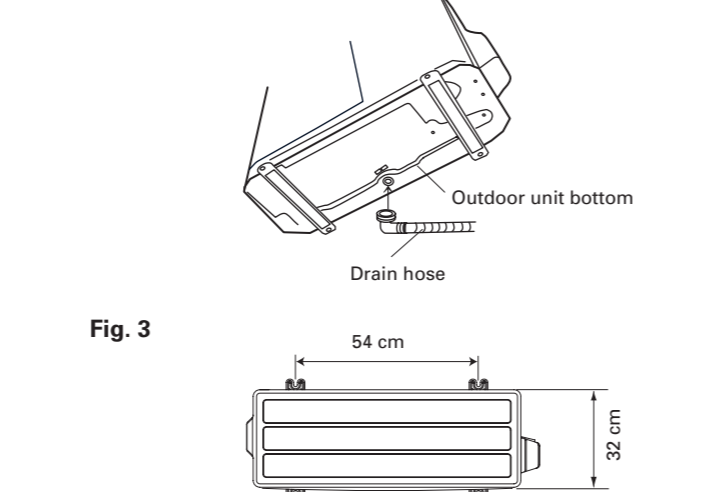

## FRONT PANEL REMOVAL AND INSTALLATION

### AIR CLEANING UNIT REMOVAL

- Open the intake grille, and then remove the right air filter.
- Pull the air cleaning unit grip in the direction of the arrow and remove the unit.

### AIR CLEANING UNIT INSTALLATION

- Open the intake grille, and then insert the dust collection unit into the indoor unit.
- Install the right air filter, and then close the intake grille.

### THE INTAKE GRILLE REMOVAL

- Open the intake grille.
- Pull down the knob.
- Lift the intake grille upward, until the axle at the top of the intake grille is removed.

### THE INTAKE GRILLE INSTALLATION

- The fixing axle of the intake grille is installed on the Panel.
- Lay down the intake grille.

### THE FRONT PANEL REMOVAL

- Remove intake grille (Reference the intake grille removal.)
- Remove four screws.
- The thumb is hung on the lower part as shown in the figure, and it pulls to the front, pushing [▽] mark, and bottom hooks (two position) is removed from wall hook bracket.
- The front panel bottom is pulled to the front, and bottom hooks is removed indoor unit.
- The front panel is pulled to the front, raising the upper surface, and a front panel is removed.

### THE FRONT PANEL INSTALLATION

- Firstly, fit the lower part of the front panel, and insert top and bottom hooks. (Three top sides, six bottom sides)
- Four screws is attached.
- The intake grille is attached.

Fig. 4

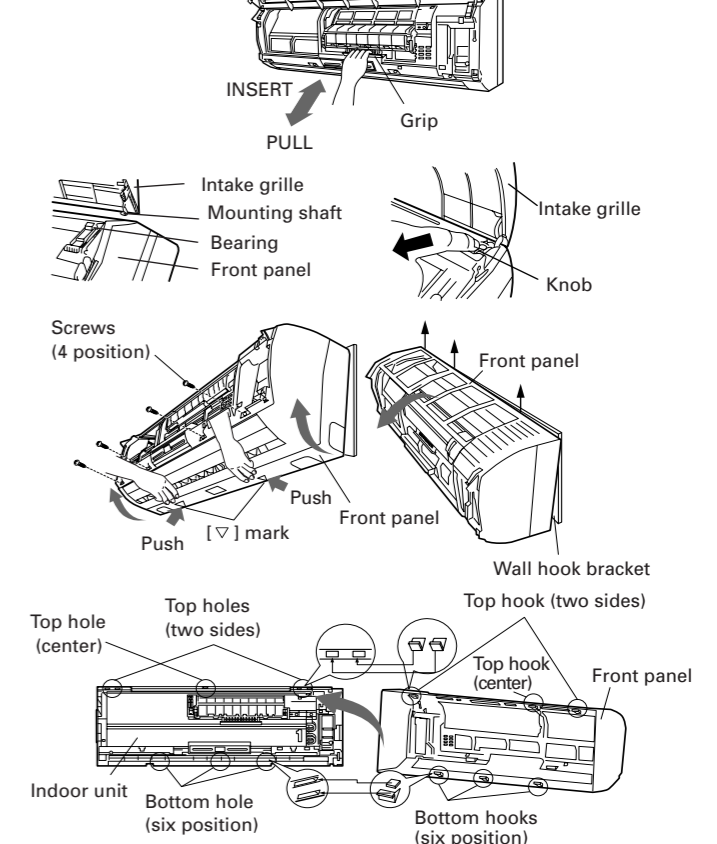

## CAUTION

Install the front panel and INTAKE GRILLE securely. If installation is imperfect, the front panel or INTAKE GRILLE may fall off and cause injury.

Be sure that the top hole of the front panel is hooked securely to the hook of the base.

## CUSTOMER GUIDANCE

Explain the following to the customer in accordance with the operating manual:

- Starting and stopping method, operation switching, temperature adjustment, timer, air flow switching, and other remote control unit operations.
- Air filter removal and cleaning, and how to use the air louvers.
- Give the operating and installation manuals to the customer.

## PUMP DOWN OPERATION (FORCED COOLING OPERATION)

To avoid discharging refrigerant into the atmosphere at the time of relocation or disposal, recover refrigerant by doing the cooling operation or forced cooling operation according to the following procedure. (When the cooling operation cannot start in winter, and so on, start the forced cooling operation.)

- Do the air purging of the charge hose by connecting the charging hose of gauge manifold to the charging port of 3 way valve and opening the low-pressure valve slightly.
- Close the valve stem of 2 way valve completely.
- Start the cooling operation or following forced cooling operation.
  - When using the remote control unit: Press the TEST RUN button after starting the cooling operation by the remote control unit. The operation indicator lamp and timer indicator lamp will begin to flash simultaneously during test run. When using the MANUAL AUTO button of the indoor unit (The remote control unit is lost, and so on.) Keep on pressing the MANUAL AUTO button of the indoor unit for more than 10 seconds. (The forced cooling operation cannot start if the MANUAL AUTO button is not kept on pressing for more than 10 seconds.)
  - Close the valve stem of 3 way valve when the reading on the compound pressure gage becomes 0.05-0 MPa (0.5-0 kg/cm<sup>2</sup>).
  - Stop the operation.
    - Press the START/STOP button of the remote control unit to stop the operation.
    - Press the MANUAL AUTO button when stopping the operation from indoor unit side. (It is not necessary to press on keeping for more than 10 seconds.)

## CAUTION

During the pump-down operation, make sure that the compressor is turned off before you remove the refrigerant piping. Do not remove the connection pipe while the compressor is in operation with 2 way or 3 way valve open. This may cause abnormal pressure in the refrigeration cycle that leads to breakage and even injury.

## POWER

### WARNING

- The rated voltage of this product is 230 V AC 50 Hz.
- Before turning on the power, check if the voltage is within the 220 V -10 % to 240 V +10 % range.
- Always use a special branch circuit and install a special receptacle to supply power to the room air conditioner.
- Use a circuit breaker and receptacle matched to the capacity of the air conditioner.
- Do not extend the power cord.
- Perform wiring work in accordance with standards so that the air conditioner can be operated safely and positively.
- Install a leakage circuit breaker in accordance with the related laws and regulations and electric company standards.

### CAUTION

- The power source capacity must be the sum of the air conditioner current and the current of other electrical appliances. When the current contracted capacity is insufficient, change the contracted capacity.
- When the voltage is low and the air conditioner is difficult to start, contact the power company the voltage raised.

Installation instruction on the back.

# INDOOR UNIT

## CUTTING THE HOLE IN THE WALL FOR THE CONNECTING PIPING

- Cut a 65 mm diameter hole in the wall at the position shown in (Fig. 5).
- When cutting the wall hole at the inside of the installation frame, cut the hole within the range of the left and right center marks 40 mm below the installation frame. When cutting the wall hole at the outside of the installation frame, cut the hole at least 10 mm below over.
- Cut the hole so that the outside end is lower (5 to 10 mm) than the inside end.
- Always align the center of the wall hole. If misaligned, water leakage will occur.
- Cut the wall pipe to match the wall thickness, stick it into the wall cap, fasten the cap with vinyl tape, and stick the pipe through the hole. (The connection pipe is supplied in the installation set.) (Fig. 5)
- For left piping and right piping, cut the hole a little lower so that drain water will flow freely. (Fig. 5)

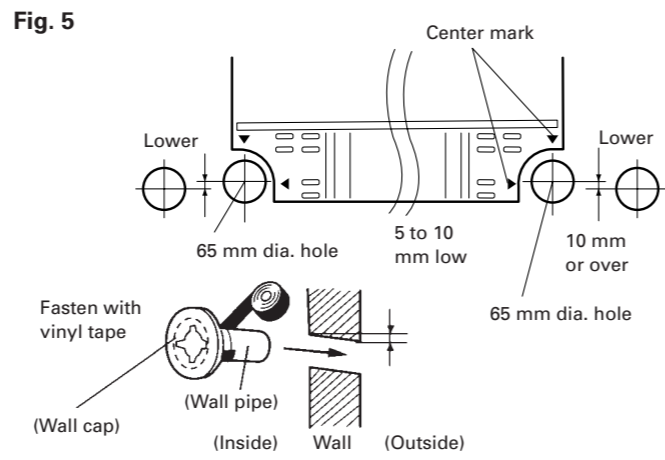

## INSTALLING THE WALL HOOK BRACKET

- Install the wall hook bracket so that it is correctly positioned horizontally and vertically. If the wall hook bracket is tiled, water will drip to the floor.
- Install the wall hook bracket so that it is strong enough to withstand the weight of an adult.
  - Fasten the wall hook bracket to the wall with 6 or more screws through the holes near the outer edge of the bracket.
  - Check that there is no rattle at the wall hook bracket.

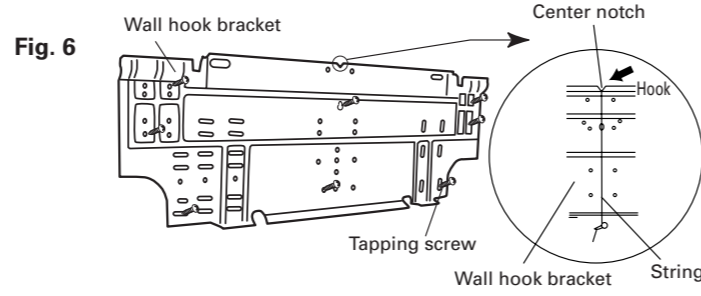

### WARNING

If the wall pipe is not used, the cord interconnecting the indoor and outdoor units may touch metal and cause electric leakage.

### CAUTION

Install the wall hook bracket horizontally and perpendicularly.

## FORMING THE DRAIN HOSE AND PIPE

### [Rear piping, Right piping, Bottom piping]

- Install the indoor unit piping in the direction of the wall hole and bind the drain hose and pipe together with vinyl tape. (Fig. 7)
- Install the piping so that the drain hose is at the bottom.
- Wrap the pipes of the indoor unit that are visible from the outside with decorative tape.

### [For Left rear piping, Left piping]

Interchange the drain cap and the drain hose.

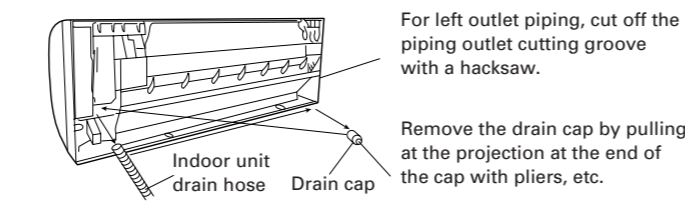
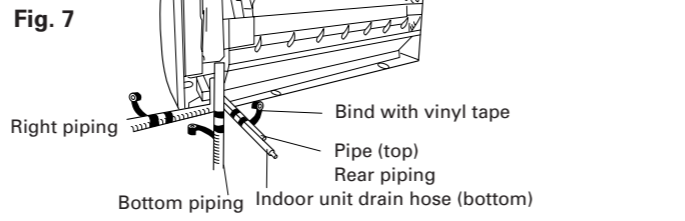

### Removal method of drain hose Installation method of drain hose

- Remove the screw at the left of drain hose and pull out drain hose.
- Vertically insert the drain hose toward the inside, so that the drain fixture (blue) can accurately align with the screw hole around the drain cock. After inserting and before replacing, please reinstall and fix the removed screws.
- Be sure to install around the drain hose connector.
- As the screw is inside, be sure to use screwdriver treated with magnet.

### CAUTION

- In order to align the drain hose and drain cap, be sure to insert securely and vertically. Incline insertion will cause water leakage.
- When inserting, be sure not to attach any material besides water. If any other material is attached, it will cause deterioration and water leakage.
- After removing drain hose, be sure not to forget mounting drain cap.
- Be sure to fix the drain hose with tape to the bottom of piping.

- For left piping and left rear piping, align the marks on the wall hook bracket and shape the connection pipe.
- Bend the connection piping at the bend radius of 70 mm or more and install no more than 35 mm from the wall.
- After passing the indoor piping and drain hose through the wall hole, hang the indoor unit on the hooks at the top and bottom of the wall hook bracket.

### [Installing the indoor unit]

- Hang the indoor unit from the hooks at the top of the wall hook bracket.
- Insert the spacer, etc. between the indoor unit and the wall hook bracket and separate the bottom of the indoor unit from the wall.

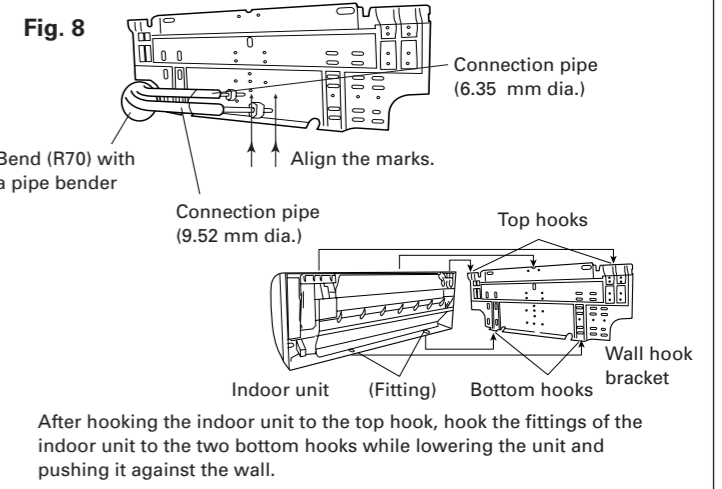
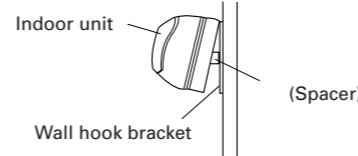

## CONNECTING THE PIPING

### CONNECTION

- Install the outdoor unit wall cap (supplied with the optional installation set or procured at the site) to the wall pipe.
- Connect the outdoor unit and indoor unit piping.
- After matching the center of the flare surface and tightening the nut hand tight, tighten the nut to the specified tightening torque with a torque wrench. (Table 2)

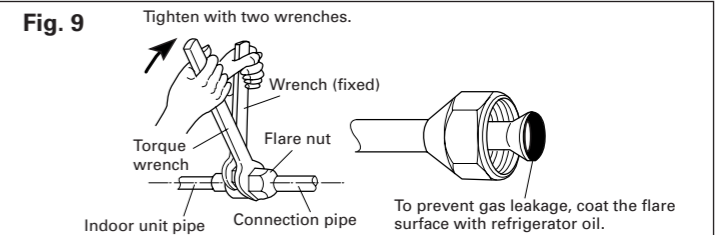

### FLARING

- Cut the connection pipe to the necessary length with a pipe cutter.
- Hold the pipe downward so that cuttings will not enter the pipe and remove the burrs.
- Insert the flare nut onto the pipe and flare the pipe with a flaring tool.

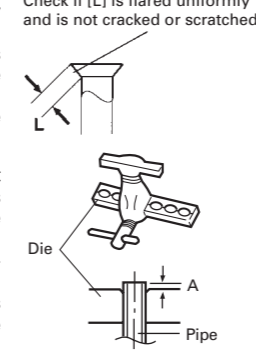

Insert the flare nut (always use the flare nut attached to the indoor and outdoor units respectively) onto the pipe and perform the flare processing with a flare tool. Use the special R410A flare tool, or the conventional (for R22) flare tool. When using the conventional flare tool, always use an allowance adjustment gauge and secure the A dimension shown in table 3.

Table 2 Flare nut tightening torque

Flare nut	Tightening torque	Tightening torque standard (using a 20 cm wrench)
6.35 mm dia.	15.7 to 17.6 N·m (160 to 180 kgf·cm)	Wrist strength
9.52 mm dia.	29.4 to 41.1 N·m (300 to 420 kgf·cm)	Arm strength

Table 3 Pipe outside diameter

Pipe outside diameter	A (mm)		
	Flash tool for R410A, clutch type	Conventional (R22) flare tool Clutch type	Wing nut type
φ 6.35 mm (1/4")	0 to 0.5	1.0 to 1.5	1.5 to 2.0
φ 9.52 mm (3/8")	0 to 0.5	1.0 to 1.5	1.5 to 2.0

### CAUTION

- Fasten a flare nut with a torque wrench as instructed in this manual. If fastened too tight, the flare nut may be broken after a long period of time and cause a leakage of refrigerant.
- During installation, make sure that the refrigerant pipe is attached firmly before you run the compressor. Do not operate the compressor under the condition of refrigerant piping not attached properly with 2-way or 3-way valve open. This may cause abnormal pressure in the refrigeration cycle that leads to breakage and even injury.

## INDOOR UNIT WIRING

- Remove the cord clamp.
- Bend the end of the connection cord as shown in the figure.

- Connect the end of the connection cord fully into the terminal block.
- Fasten the connection cord with a cord clamp.

Fig. 10

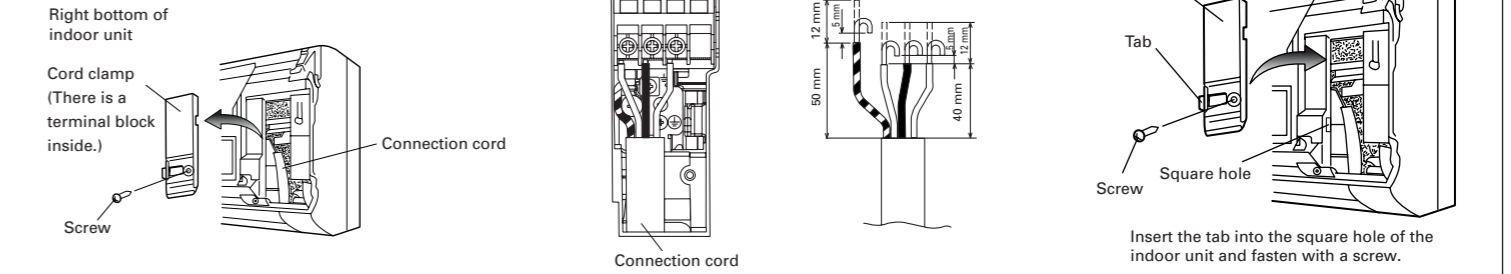

### CAUTION

- Match the terminal block numbers and connection cord colors with those of the outdoor unit. Erroneous wiring may cause burning of the electric parts.
- Connect the connection cords firmly to the terminal block. Imperfect installation may cause a fire.
- Always fasten the outside covering of the connection cord with the cord clamp. (If the insulator is chafed, electric leakage may occur.)
- Securely earth the power cord plug.
- Do not use the earth screw for an external connector. Only use for interconnection between two units.

# OUTDOOR UNIT

## OUTDOOR UNIT INSTALLATION

- Set the unit on a strong stand, such as one made of concrete blocks to minimize shock and vibration.
- Do not set the unit directly on the ground because it will cause trouble.

### Connector cover removal

- Remove the tapping screws.

### Installing the connector cover

- After inserting the two front hooks, then insert the rear hook.
- Tighten the tapping screws.

### WARNING

- Install the unit where it will not be tilted by more than 5°.
- When installing the outdoor unit where it may be exposed to strong wind, fasten it securely.

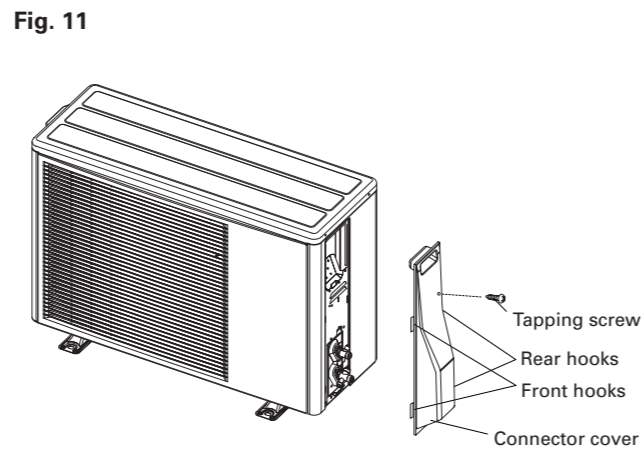

## AIR PURGE

Always use a vacuum pump to purge the air. Refrigerant for purging the air is not charged in the outdoor unit at the factory.

Close the high pressure side valve of the gauge manifold fully and do not operate it during the following work.

- Check if the piping connections are secure.
- Check that the stems of 2-way valve and 3-way valve are closed fully.
- Connect the gauge manifold charge hose to the charging port of the 3-way valve (side with the projection for pushing in the valve core).
- Open the low pressure side valve of the gauge manifold fully.
- Operate the vacuum pump and start pump down.
- Slowly loosen the flare nut of the 3-way valve and check if air enters, then retighten the flare nut. (When the flare nut is loosened the operating sound of the vacuum pump changes and the reading of the compound pressure gauge goes from minus to zero.)
- Pump down the system for at least 15 minutes, then check if the compound pressure gauge reads -0.1 MPa (-76 cmHg, -1 bar).
- At the end of pump down, close the low pressure side gauge of the gauge manifold fully and stop the vacuum pump.
- Slowly loosen the valve stem of the 3-way valve. When the compound pressure gauge reading reaches 0.1-0.2 MPa, retighten the valve stem and disconnect the charge hose from the 3-way valve charging port. (If the stem of the 3-way valve is opened fully before the charge hose is disconnected, it may be difficult to disconnect the charge hose.)

### CAUTION

- Refrigerant must not be discharged into atmosphere.
- After connecting the piping, check the joints for gas leakage with gas leak detector.

- Fully open the valve stems of the 2-way valve and 3-way valve using a hexagon wrench. (After the valve stem begins to turn, turn it with a torque of less than 2.9 N·m (30 kgf·cm) until it stops turning.)
- Firmly tighten the 2-way valve and 3-way valve blank cap and the charging port cap.

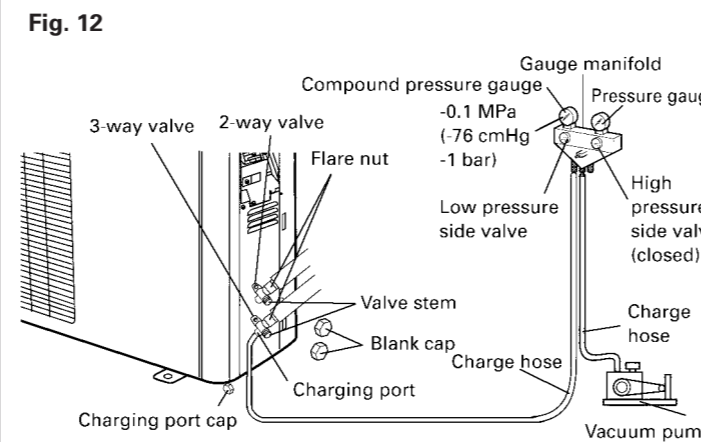

Table 4

	Tightening torque
Blank cap	19.6 to 24.5 N·m (200 to 250 kgf·cm)
Charging port cap	12.3 to 15.7 N·m (125 to 160 kgf·cm)

### CAUTION

- When adding refrigerant, add the refrigerant from the charging port at the completion of work.
- The maximum length of the piping is 20 m. If the units are further apart than this, correct operation can not be guaranteed.

Between 15 m and 20 m, when using a connection pipe other than that in the table, charge additional refrigerant with 20g/1 m as the criteria.

### Additional charge

Refrigerant suitable for a piping length of 15 m is charged in the outdoor unit at the factory. When the piping is longer than 15 m, additional charging is necessary. For the additional amount, see the table below.

Table 5

Pipe length	15 m	20 m
Additional refrigerant	None	100 g

## OUTDOOR UNIT WIRING

- Remove the outdoor unit connector cover.
- Bend the end of the cord as shown in the figure.
- Connect the end of the connection cord fully into the terminal block.
- Fasten the sheath with a cord clamp.
- Install the connector cover.

Fig. 13

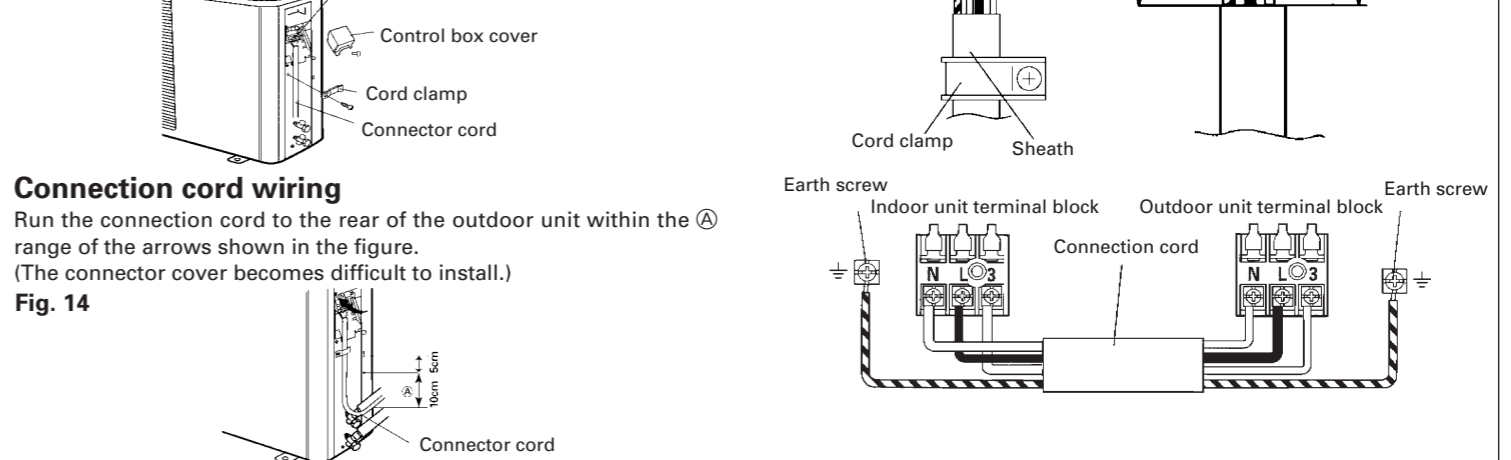

### Connection cord wiring

Run the connection cord to the rear of the outdoor unit within the range of the arrows shown in the figure. (The connector cover becomes difficult to install.)

Fig. 14

### CAUTION

- Match the terminal block numbers and connection cord colors with those of the indoor unit. Erroneous wiring may cause burning of the electric parts.
- Connect the connection cords firmly to the terminal block. Imperfect installation may cause a fire.
- Always fasten the outside covering of the connection cord with the cord clamp. (If the insulator is chafed, electric leakage may occur.)
- Securely earth the power cord plug.
- Do not use the earth screw for an external connector. Only use for interconnection between two units.

## FINISHING

- Insulate between pipes.
  - For rear, right, and bottom piping, overlap the connection pipe heat insulation and indoor unit pipe heat insulation and bind them with vinyl tape so that there is no gap.
  - For left and left rear piping, butt the connection pipe heat insulation and indoor unit pipe heat insulation together and bind them with vinyl tape so that there is no gap.
  - For left and left rear piping, wrap the area which accommodates the rear piping housing section with cloth tape.
  - For left and left rear piping, bind the connection cord to the top of the pipe with vinyl tape.
  - For left and left rear piping, bundle the piping and drain hose together by wrapping them with cloth tape over the range within which they fit into the rear piping housing section.
- Temporarily fasten the connection cord along the connection pipe with vinyl tape. (Wrap to about 1/3 the width of the tape from the bottom of the pipe so that water does not enter.)
- Fasten the connection pipe to the outside wall with saddles, etc.
- Fill the gap between the outside wall pipe hole and the pipe with sealer so that rain water and wind cannot blow in.
- Fasten the drain hose to the outside wall, etc.

Fig. 15



Fig. 16

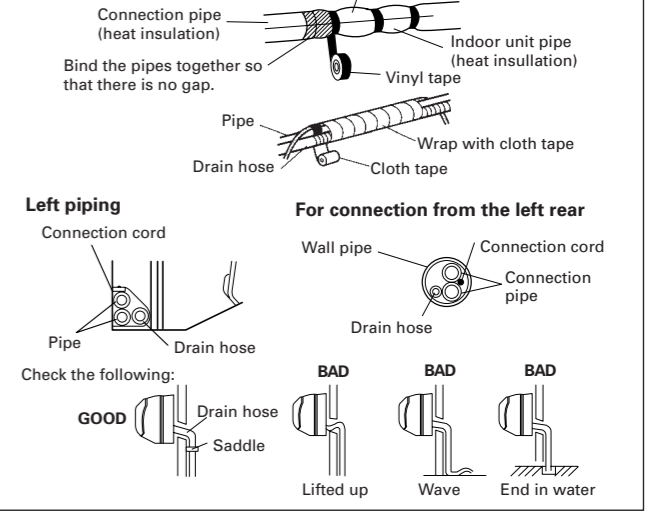

## TEST RUNNING

- Perform test operation and check items 1 and 2 below.
- For the test operation method, refer to the operating manual.
- The outdoor unit, may not operate, depending on the room temperature. In this case, press the test run button on the remote control unit while the air conditioner is running. (Point the transmitter section of the remote control unit toward the air conditioner and press the test run button with the tip of a ball-point pen, etc.)
- To end test operation, press the remote control unit START/STOP button. (When the air conditioner is run by pressing the test run button, the OPERATION indicator lamp and TIMER indicator lamp will simultaneously flash slowly.)

### 1. INDOOR UNIT

- Is operation of each button on the remote control unit normal?
- Does each lamp light normally?
- Do the air flow-direction louvers operate normally?
- Is the drain normal?

### 2. OUTDOOR UNIT

- Is there any abnormal noise and vibration during operation?
- Will noise, wind, or drain water from the unit disturb the neighbors?
- Is there any gas leakage?

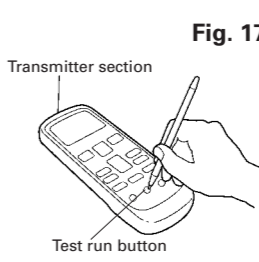

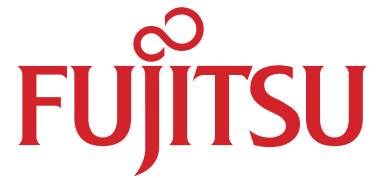

## **FUJITSU GENERAL LIMITED**

---

1116, Suenaga, Takatsu-ku, Kawasaki 213-8502, Japan