

Baxi Brazilia F 5, F 5S, F 8S & Comfort Stat F8ST Oak

Balanced Flue Gas Wall Heaters

User's Operating Instructions

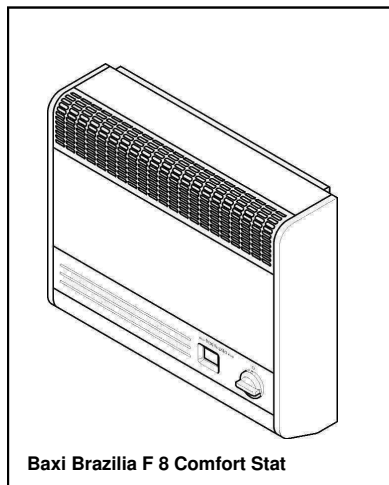
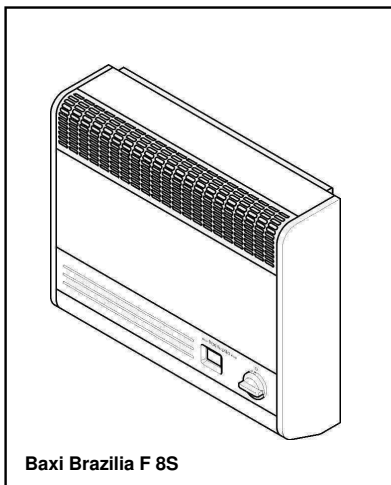
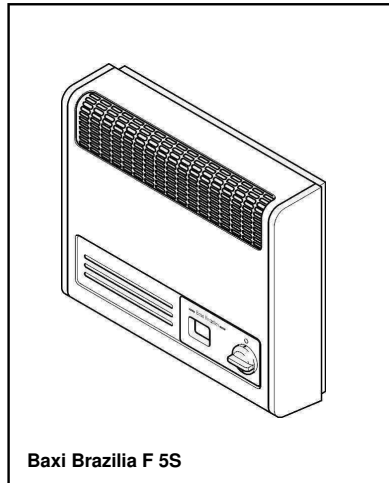
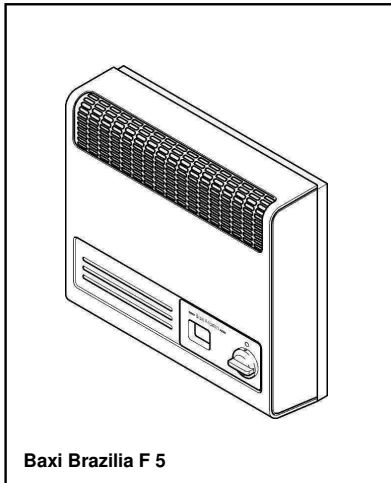

BAXI

Natural Gas

Baxi Brazilia F 5
G.C.No. 35 075 01A

Baxi Brazilia F 5S Grey
G.C.No. 35 075 02A
Baxi Brazilia F 5S Mahogany
G.C.No. 35 075 02A
Baxi Brazilia F 5S Oak
G.C.No. 35 075 02A

Baxi Brazilia F 8S Grey
G.C.No. 35 075 03A
Baxi Brazilia F 8S Mahogany
G.C.No. 35 075 03A
Baxi Brazilia F 8S Oak
G.C.No. 35 075 03A
Baxi Brazilia Comfortstat F8ST Oak
G.C.No. 35 075 09

Propane

Baxi Brazilia F 5 Propane
G.C.No. 35 075 04A

Baxi Brazilia F 5S Grey Propane
G.C.No. 35 075 05A

Baxi Brazilia F 8S Grey Propane
G.C.No. 35 075 06A

Baxi Heating Ltd is one of the leading manufacturers of domestic heating products in the UK.

Our first priority is to give a high quality service to our customers. Quality is built into every Baxi product - products which fulfil the demands and needs of customers, offering choice, efficiency and reliability.

To keep ahead of changing trends, we have made a commitment to develop new ideas using the latest technology - with the aim of continuing to make the products that customers want to buy.

Baxi is also the largest manufacturing partnership in the country. Everyone who works at the company has a commitment to quality because, as shareholders, we know that satisfied customers mean continued success.

We hope you get a satisfactory service from Baxi. If not, please let us know.

For GB/IE only.



Baxi is a BS-EN ISO 9001
Accredited Company

1.0 Warnings

1.1 Safe Installation

1. The appliance is suitable for installation only in G.B. and I.E. and should be installed in accordance with the rules in force. For Ireland install in accordance with I.S.813 "Domestic gas installations". The installation must be carried out by a CORGI Registered Installer or other competent person and be in accordance with the relevant requirements of **GAS SAFETY** (Installation and Use) **REGULATIONS** latest edition, the **BUILDING REGULATIONS** issued by the Department of the Environment, **BUILDING STANDARDS** (Scotland) (Consolidation) **REGULATIONS** issued by the Scottish Development Department and the **LOCAL BUILDING REGULATIONS**. Where no specific instructions are given, reference should be made to the relevant **BRITISH STANDARD CODES OF PRACTICE** and **INSTALLATION SPECIFICATIONS**.

2. **This appliance must be installed in accordance with the manufacturers instructions and the rules in force.**

3. **Read the instructions before installing or using this appliance.**

1.2 In case of gas leaks

If a gas leak is found or suspected, turn off the gas supply at the meter immediately and contact your Installer, British Gas Emergency (under 'Gas' in the phone directory) or the gas supplier.

1.3 Guarding

During use the top and front of the appliance are working surfaces and become very hot. It is recommended that a guard conforming with B.S. 8423 is used, especially in instances where young children, the elderly or infirm are likely to be present.

WARNING: Never Hang Flammable Items Over The Appliance

1.4 Servicing your Appliance

For reasons of safety and economy your appliance should be serviced annually. Your Installer or British Gas Service will be able to advise you.

The external flue terminal must be kept free from obstruction at all times. If the terminal is less than 2m (6ft.) from ground level, a balcony or other place to which any person has access a suitable terminal guard must be fitted.

Notice

Discolouration of wall surfaces

Most heating appliances generate warm air convection currents and transfer heat to any wall surface against which they are situated.

Some soft furnishings (such as blown vinyl wallpapers) may not be suitable for use where they are subject to temperatures above normal room levels and the manufacturer's advice should be sought before using this type of wall covering adjacent to any heating appliance.

The likelihood of wall staining from convected air currents will be increased in environments where high levels of tobacco smoke or other contaminants exist.

2.0 Introduction & Operation

2.1 Introduction

1. Your Baxi Brazilia F is a room sealed gas convector heater. This means that the gas burning section is sealed from the room in which it is installed. It is connected to a circular flue terminal outside the building. This terminal is the inlet for air required to burn the gas and also the outlet for the flue gases.

2.2 Operating the Unit

1. The appliance is controlled by a knob which is positioned at the lower right on the front of case (Fig. 1).

Except for the comfort stat, the knob has five positions.

Position ●	OFF
Position I	LOW
Position ★	IGNITION
Position II	MEDIUM
Position III	HIGH

Comfort stat, the knob has four positions.

Position ●	OFF
Position ★	IGNITION PRESET
	HIGH
	LOW

2. **To light the appliance** (Fig 2a): At the OFF (●) position push in the control knob as far as possible and still pushing in turn anti-clockwise to the ignition position (★) to light the burner. Keep the knob pushed in for 20 seconds and the burner should remain alight. If not, repeat the sequence.

NOTE: Under extreme wind conditions more than one attempt to light the appliance may be required.

3. Except Comfort Stat. Once lit, the control knob can be altered to any of the three heat settings.

Comfort Stat. Once lit, the control knob can be moved from the pre-set ignition position into the band to give a variable temperature setting.

4. When first lit after installation some smells are likely to be emitted. These will quickly clear away with use.

NOTE: If the appliance goes out at any time wait 3 minutes and repeat the procedure. When changing from one setting to another the knob should always be pushed in slightly.

5. **To turn the appliance off:** Push the knob in slightly and turn to the OFF (●) position.

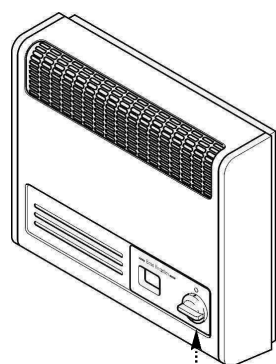

Fig. 1

Control Knob

Relative positions of markings on side of control knob.

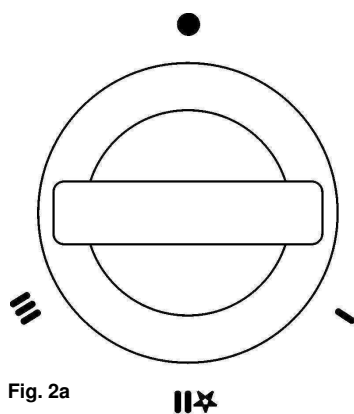

Fig. 2a

Position ● - OFF
 Position I - LOW
 Position ★ - IGNITION
 Position II - MEDIUM
 Position III - HIGH

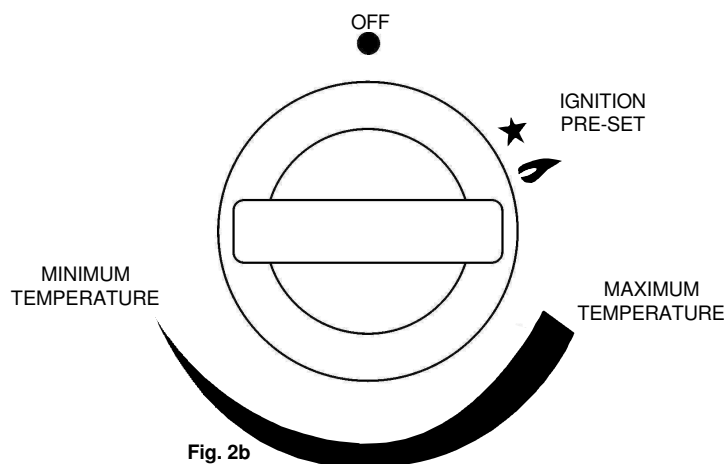

Fig. 2b

3.0 Cleaning & Clearances

3.1 Cleaning the Appliance

1. When cold the appliance may be cleaned with a damp cloth and wiped with a soft duster. Do not use abrasive cleaning agents, wax or spray polish.

3.2 Clearances

1. Internally the appliance must not be fitted under a shelf or sill that projects more than 150mm (6in.)
 2. Curtains or a shelf must not be closer to the top of the outer case than 140mm (5¹/₂in) for F 5 & F 5S or 89mm (3¹/₂in) for F 8S & F 8ST models.
 3. The minimum side clearances from any wall or fixed furniture are:-
Left hand side 45mm (1³/₄in)
Right hand side 57mm (2¹/₄in)
-

4.0 Spares & Running Costs

4.1 Spare Parts

1. The appliance is the responsibility of the installer for the first twelve months, after which time if spare parts are required they can be obtained through Baxi Spares Stockists.
 2. Always quote the appliance model name and G.C. number. The G.C. number can be found on page 2 of these instructions.
 3. A "Special Needs Adaptor" is available for use with the Baxi Brazilia F. This is designed for customers suffering from arthritis or similar conditions and provides the user with extra leverage when operating the control knob. It is available from Baxi Spares Stockists.
-

4.2 Running Costs

1. The running cost of the appliance is quoted in kilowatt hours (kWh). The price per kilowatt hour varies and is shown on your gas bill.
2. The table below shows the approximate time taken by the appliance to consume 1 kWh of energy on minimum and maximum rates.

	F 5 & 5S	F 8S & F8ST
High I	29 minutes	19 minutes
Low I	1 hour 8 minutes	47 minutes

Baxi Heating Ltd manufacture a comprehensive range of products for the domestic heating market.

**Gas Central Heating Boilers
(Wall, Floor and Fireside models).**

Independent Gas Fires.

Renewal Firefronts.

Gas Wall Heaters.

Solid Fuel Fires.

If you require information on any of these products, please write, telephone or fax to the Sales Department.

The Baxi Helplines

For General Enquiries
+44 (0) 8706 061 064

For After Sales Service
+44 (0) 8706 090 081

For Technical Enquiries
+44 (0) 8706 061 065

BAXI

Baxi Fires Division

Wood Lane
Erdington
Birmingham
B24 9QP

www.firesandstoves.co.uk