

SBK ST

SCAMBIATORE A PIASTRE

→ Scambiatore di calore

→ A piastre



Equipaggiamento

- Scambiatore a piastre interamente costruito in metallo
- Piastre in acciaio inox
- Pressione di utilizzo 10 bar
- Pressione di prova 14 bar



SBK ST

Modello	Codice
SBK 1 ST	102257
SBK 2 ST	102252
SBK 3 ST	102242
SBK 4 ST	102243
SBK 5 ST	102246
SBK 6 ST	102258
SBK 7 ST	102259
SBK 8 ST	102244
SBK 9 ST	102247
SBK 10 ST	102260
SBK 11 ST	102261
SBK 12 ST	102262
SBK 13 ST	102263
SBK 14 ST	102264
SBK 15 ST	102265

- Scambiatore compatto in metallo
- Alta efficienza termica
- Adatto ad applicazioni che richiedono poco spazio senza costose manutenzioni

DIMENSIONI SBK ST (in mm)

Modello	A	B	L	Attacchi	Peso
	mm	mm	mm	"	Kg
SBK 1 ST	754	200	150	1"1/4	47,2
SBK 2 ST	754	200	150	1"1/4	49
SBK 3 ST	754	200	300	1"1/4	56
SBK 4 ST	870	320	300	2"	114
SBK 5 ST	870	320	300	2"	115,3
SBK 6 ST	870	320	300	2"	118,3
SBK 7 ST	870	320	500	2"	128,5
SBK 8 ST	870	320	500	2"	132,9
SBK 9 ST	987	384	500	DN 65	209,1
SBK 10 ST	987	384	500	DN 65	229,9
SBK 11 ST	1039	465	700	DN 100	317,2
SBK 12 ST	1039	465	700	DN 100	324,6
SBK 13 ST	1039	465	700	DN 100	334,4
SBK 14 ST	1039	465	1000	DN 100	341,7
SBK 15 ST	1039	465	1000	DN 100	349,1

DIMENSIONALE SBK ST

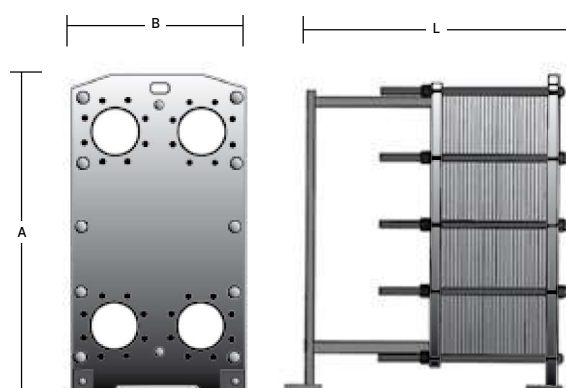

SCHEMA DI COLLEGAMENTO

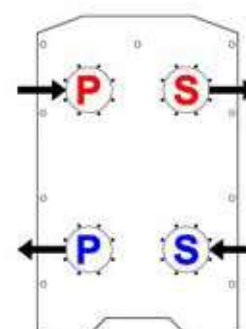

TABELLA DI SELEZIONE

Modello	Potenza	Temp. I	Temp. II	Portata I	Portata II	PDC I	PDC II	Superficie
	kW	°C	°C	m³/h	m³/h	KPa	KPa	m²
SBK 1 ST	40	80/60	70/50	1.76	1.75	14	18	1.01
SBK 2 ST	60	80/60	70/50	2.63	2.62	14	18	1,51
SBK 3 ST	100	80/60	70/50	4.4	5.85	14	18	2.86
SBK 4 ST	150	80/60	70/50	6.7	6.6	11.5	11.8	2.85
SBK 5 ST	180	80/60	70/50	8	7.9	13.8	14.1	3.15
SBK 6 ST	220	80/60	70/50	9.8	9.6	14.3	14.5	3.75
SBK 7 ST	350	80/60	70/50	15.5	15.3	14.7	14.9	5.85
SBK 8 ST	400	80/60	70/50	17.6	17.5	14.2	14.4	6.75
SBK 9 ST	600	80/60	70/50	26.6	26.3	15	15	11.36
SBK 10 ST	800	80/60	70/50	35.4	35.1	15	15	16.04
SBK 11 ST	1000	80/60	70/50	44.3	43.7	14.2	16.3	17.04
SBK 12 ST	1100	80/60	70/50	48.8	48.1	14.5	16.8	18.48
SBK 13 ST	1200	80/60	70/50	53.2	52.4	14	16	20.4
SBK 14 ST	1300	80/60	70/50	57.6	56.8	14.2	17	22.08
SBK 15 ST	1400	80/60	70/50	62.1	61.2	14.8	17.7	23.52